

SONY®

TRINITRON® COLOR VIDEO MONITOR

BVM-A14F5M

BVM-A14F5U

BVM-A14F5A



Multiformat



SERVICE MANUAL

1st Edition

⚠ 警告

このマニュアルは、サービス専用です。

お客様が、このマニュアルに記載された設置や保守、点検、修理などを行うと感電や火災、人身事故につながる可能性があります。

危険をさけるため、サービストレーニングを受けた技術者のみご使用ください。

⚠ WARNING

This manual is intended for qualified service personnel only.

To reduce the risk of electric shock, fire or injury, do not perform any servicing other than that contained in the operating instructions unless you are qualified to do so. Refer all servicing to qualified service personnel.

⚠ WARNUNG

Die Anleitung ist nur für qualifiziertes Fachpersonal bestimmt.

Alle Wartungsarbeiten dürfen nur von qualifiziertem Fachpersonal ausgeführt werden. Um die Gefahr eines elektrischen Schlages, Feuergefahr und Verletzungen zu vermeiden, sind bei Wartungsarbeiten strikt die Angaben in der Anleitung zu befolgen. Andere als die angegebenen Wartungsarbeiten dürfen nur von Personen ausgeführt werden, die eine spezielle Befähigung dazu besitzen.

⚠ AVERTISSEMENT

Ce manuel est destiné uniquement aux personnes compétentes en charge de l'entretien. Afin de réduire les risques de décharge électrique, d'incendie ou de blessure n'effectuer que les réparations indiquées dans le mode d'emploi à moins d'être qualifié pour en effectuer d'autres. Pour toute réparation faire appel à une personne compétente uniquement.

Attention-when the product is installed in Rack:

1. Prevention against overloading of branch circuit

When this product is installed in a rack and is supplied power from an outlet on the rack, please make sure that the rack does not overload the supply circuit.

2. Providing protective earth

When this product is installed in a rack and is supplied power from an outlet on the rack, please confirm that the outlet is provided with a suitable protective earth connection.

3. Internal air ambient temperature of the rack

When this product is installed in a rack, please make sure that the internal air ambient temperature of the rack is within the specified limit of this product.

4. Prevention against achieving hazardous condition due to uneven mechanical loading

When this product is installed in a rack, please make sure that the rack does not achieve hazardous condition due to uneven mechanical loading.

5. Install the equipment while taking the operating temperature of the equipment into consideration

For the operating temperature of the equipment, refer to the specifications of the Operation Manual.

6. When performing the installation, keep the following space away from walls in order to obtain proper exhaust and radiation of heat.

Rear: 10 cm (4 inches) or more

X-RAY RADIATION WARNING

Be sure that parts replacement in the high voltage block and adjustments made to the high voltage circuits are carried out precisely in accordance with the procedures given in this manual.

For safety, do not connect the connector for peripheral device wiring that might have excessive voltage to the following port(s).

: LAN connector

Follow the instructions for the above port(s).

Table of Contents

1. Service Information

1-1. Appearance Figure	1-1
1-2. Board Locations	1-1
1-3. Disassembly	1-2
1-3-1. BC Board	1-4
1-3-2. BK Board	1-5
1-3-3. CA Board	1-6
1-3-4. CA Board and ZCA Board	1-7
1-3-5. EA Board and E Board	1-8
1-3-6. E Board and Z Board	1-9
1-3-7. EA Board and Z Board	1-9
1-3-8. G Board	1-10
1-3-9. C Board	1-11
1-3-10. TA Board	1-12
1-3-11. Cabinet	1-12
1-3-12. TB Board	1-13
1-3-13. PA Board	1-13
1-3-14. PC Board	1-14
1-3-15. CRT	1-15
1-3-16. Bezel Assembly-1	1-16
1-3-17. Bezel Assembly-2	1-17
1-3-18. Anode Cap	1-18
1-4. Writing and Rewriting PLD Internal Data	1-19

2. Setup Adjustment

2-1. Setup Adjustment When CRT is Replaced	2-1
--	-----

3. Safety-Related Adjustments

4. Circuit Adjustments

4-1. BK Board Adjustments	4-1
---------------------------------	-----

5. Semiconductor Pin Assignments

6. Spare Parts

6-1. Notes on Repair Parts	6-1
6-2. Exploded Views	6-2
6-3. Electrical Parts List	6-9

7. Block Diagrams

Overall (1/2)	7-1
Overall (2/2)	7-2
BK (1/5)	7-3
BK (2/5)	7-4
BK (3/5)	7-5
BK (4/5)	7-6
BK (5/5)	7-7
CA, C	7-8
EA (1/2)	7-9
EA (2/2)	7-10
DY, E	7-11
PA, PC	7-12
BC (1/3)	7-13
BC (2/3)	7-14
BC (3/3)	7-15
G	7-16
TB, YA, YB, YC	7-17
TA	7-18
HC (1/2)	7-19
HA, HB, HC (2/2), HD	7-20

8. Schematic Diagrams

Frame (1/2)	8-2
Frame (2/2)	8-3
BC (1/7)	8-4
BC (2/7)	8-5
BC (3/7)	8-6
BC (4/7)	8-7
BC (5/7)	8-8
BC (6/7)	8-9
BC (7/7)	8-10

BK (1/15)	8-11
BK (2/15)	8-12
BK (3/15)	8-13
BK (4/15)	8-14
BK (5/15)	8-15
BK (6/15)	8-16
BK (7/15)	8-17
BK (8/15)	8-18
BK (9/15)	8-19
BK (10/15)	8-20
BK (11/15)	8-21
BK (12/15)	8-22
BK (13/15)	8-23
BK (14/15)	8-24
BK (15/15)	8-25
C	8-26
CA	8-27
E (1/2)	8-28
E (2/2)	8-29
EA (1/5)	8-30
EA (2/5)	8-31
EA (3/5)	8-32
EA (4/5)	8-33
EA (5/5)	8-34
G (1/2)	8-35
G (2/2)	8-36
HA	8-37
HB	8-38
HC (1/4)	8-39
HC (2/4)	8-40
HC (3/4)	8-41
HC (4/4)	8-42
HD	8-43
PA	8-44
PC	8-45
TA	8-46
TB	8-47
YA	8-48
YB	8-48
YC	8-48

9. Board Layouts

BC	9-2
BK	9-4
C	9-6
CA	9-7
E	9-9
EA	9-11
G	9-13
HA	9-15
HB	9-15
HC	9-16
HD	9-16
PA	9-17
PC	9-17
TA	9-18
TB	9-19
YA	9-20
YB	9-20
YC	9-20

Section 1

Service Information

1-1. Appearance Figure

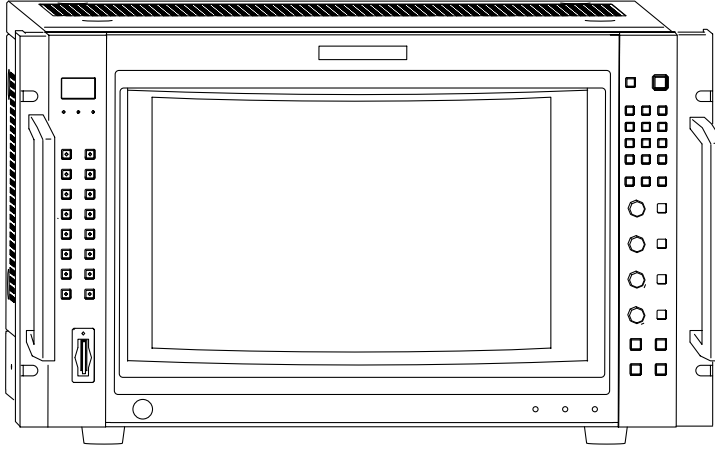

1-2. Board Locations

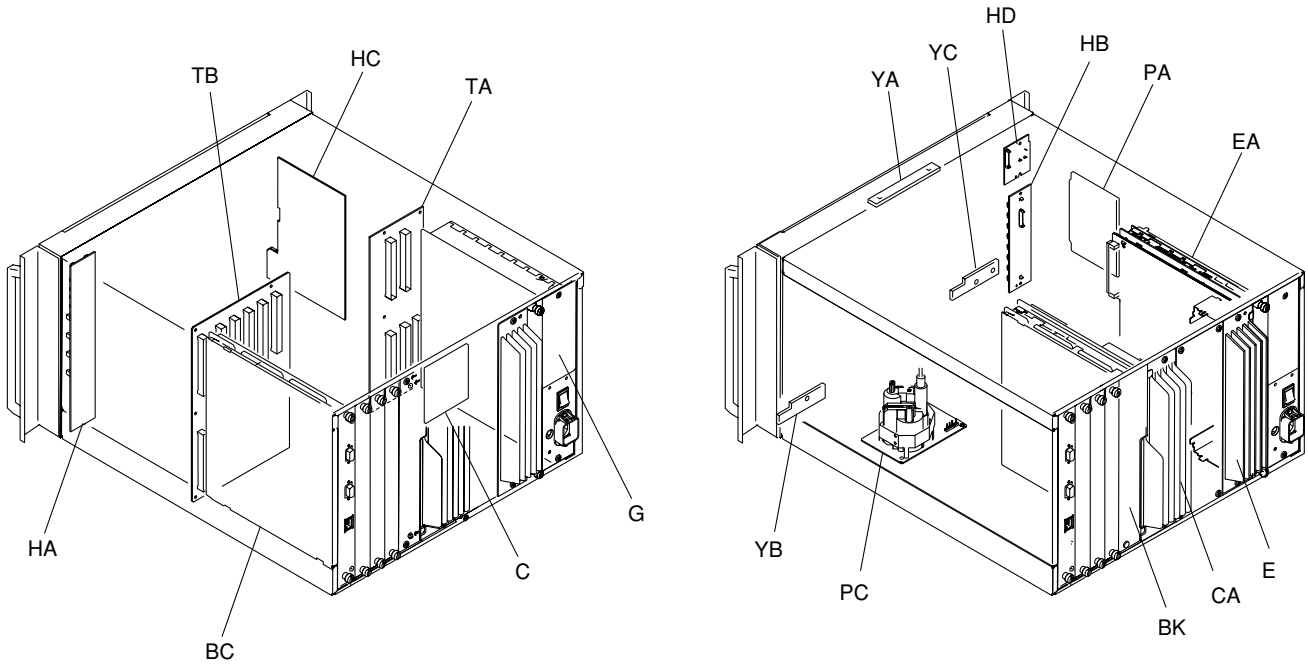

1-3. Disassembly

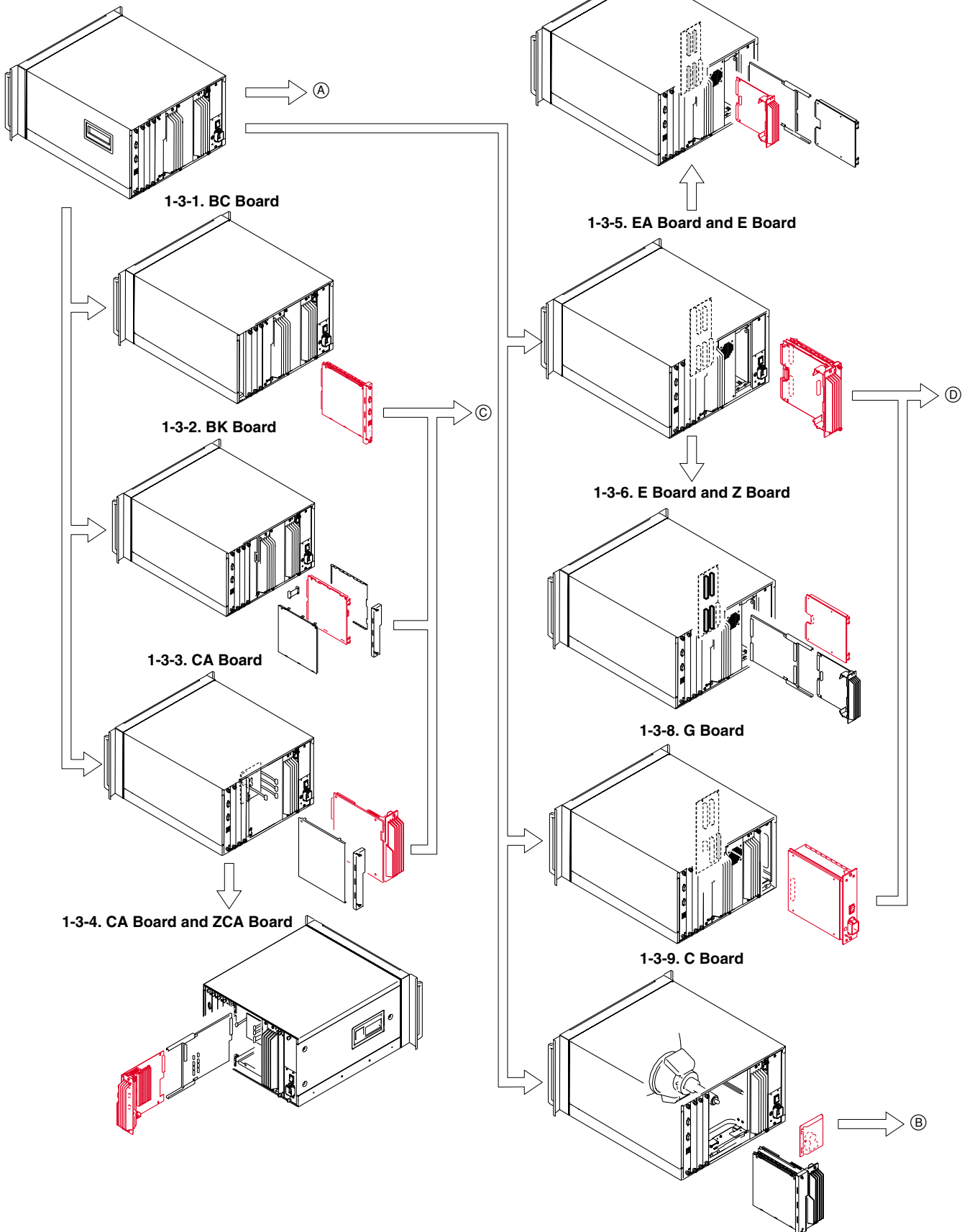

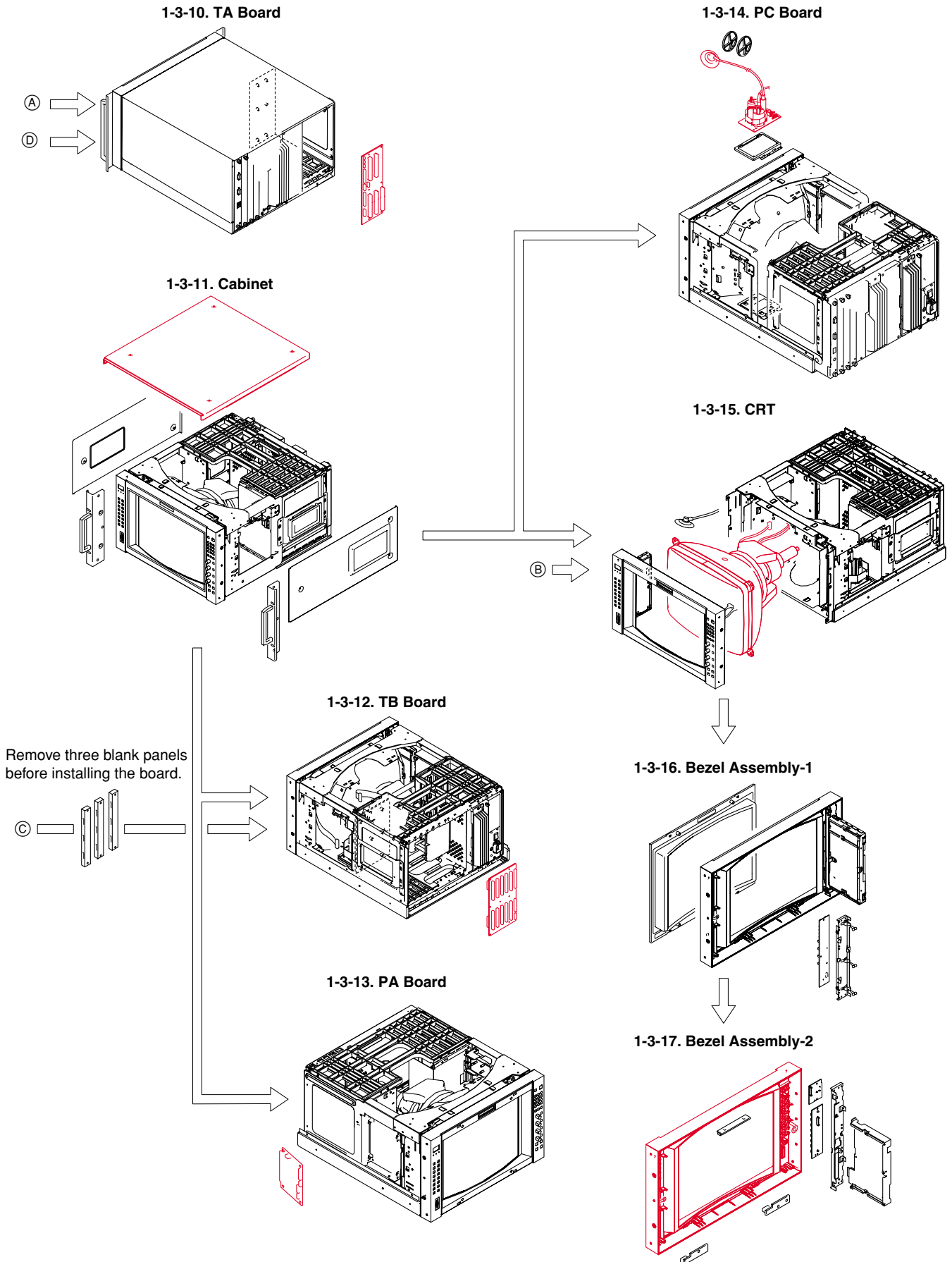

1-3-1. BC Board

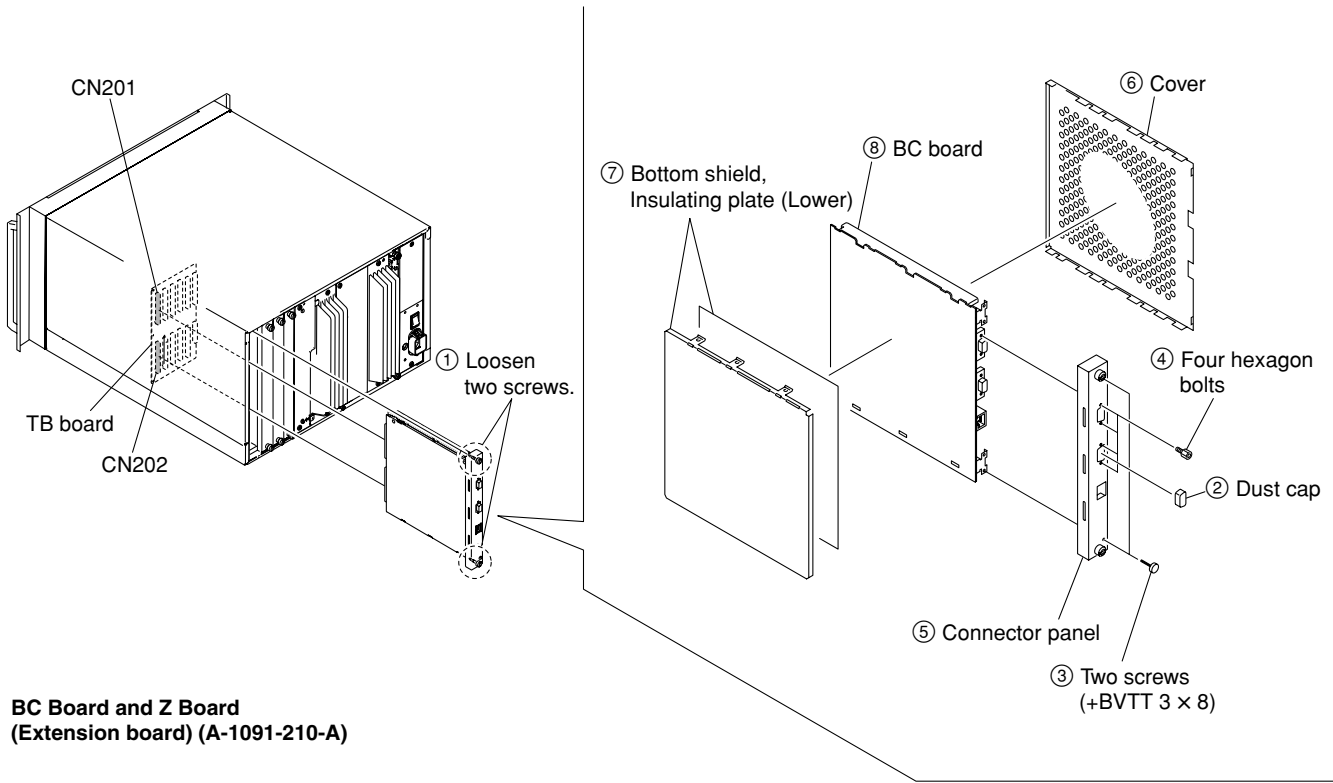

BC Board and Z Board (Extension board) (A-1091-210-A)

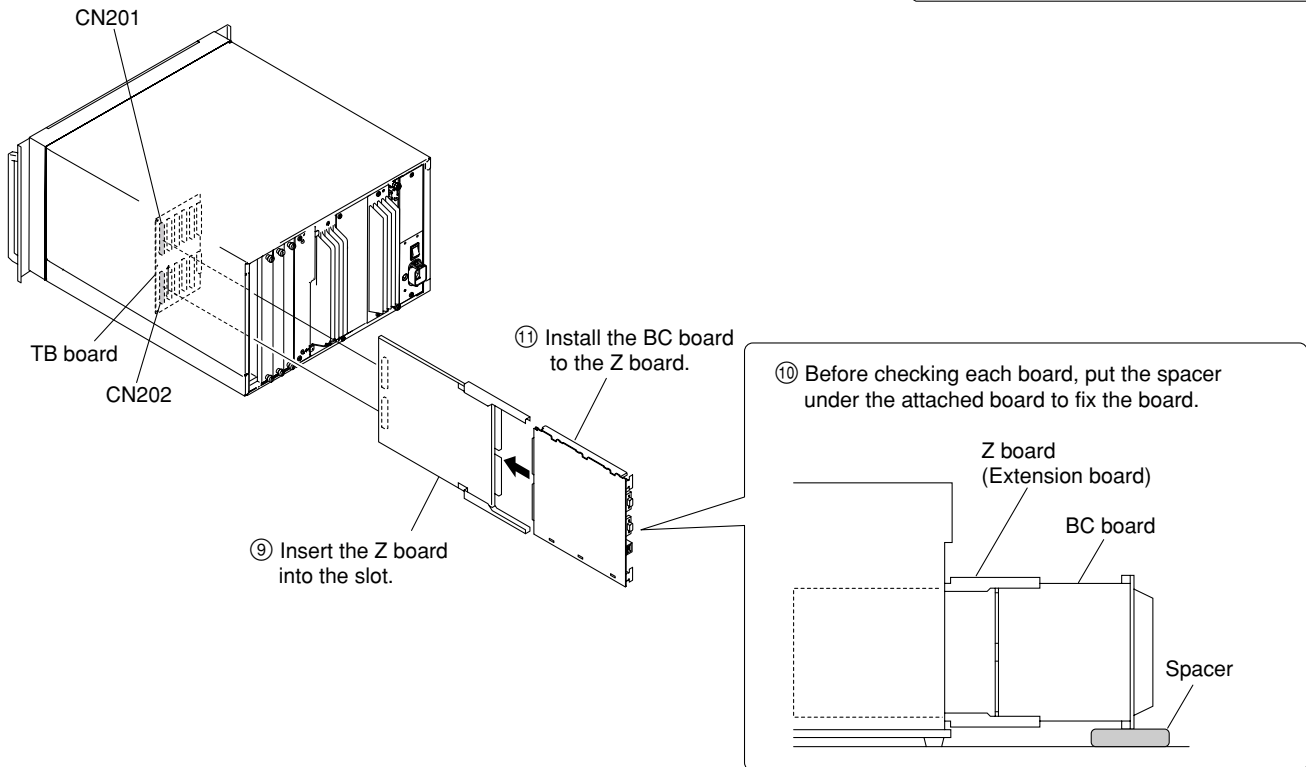

1-3-2. BK Board

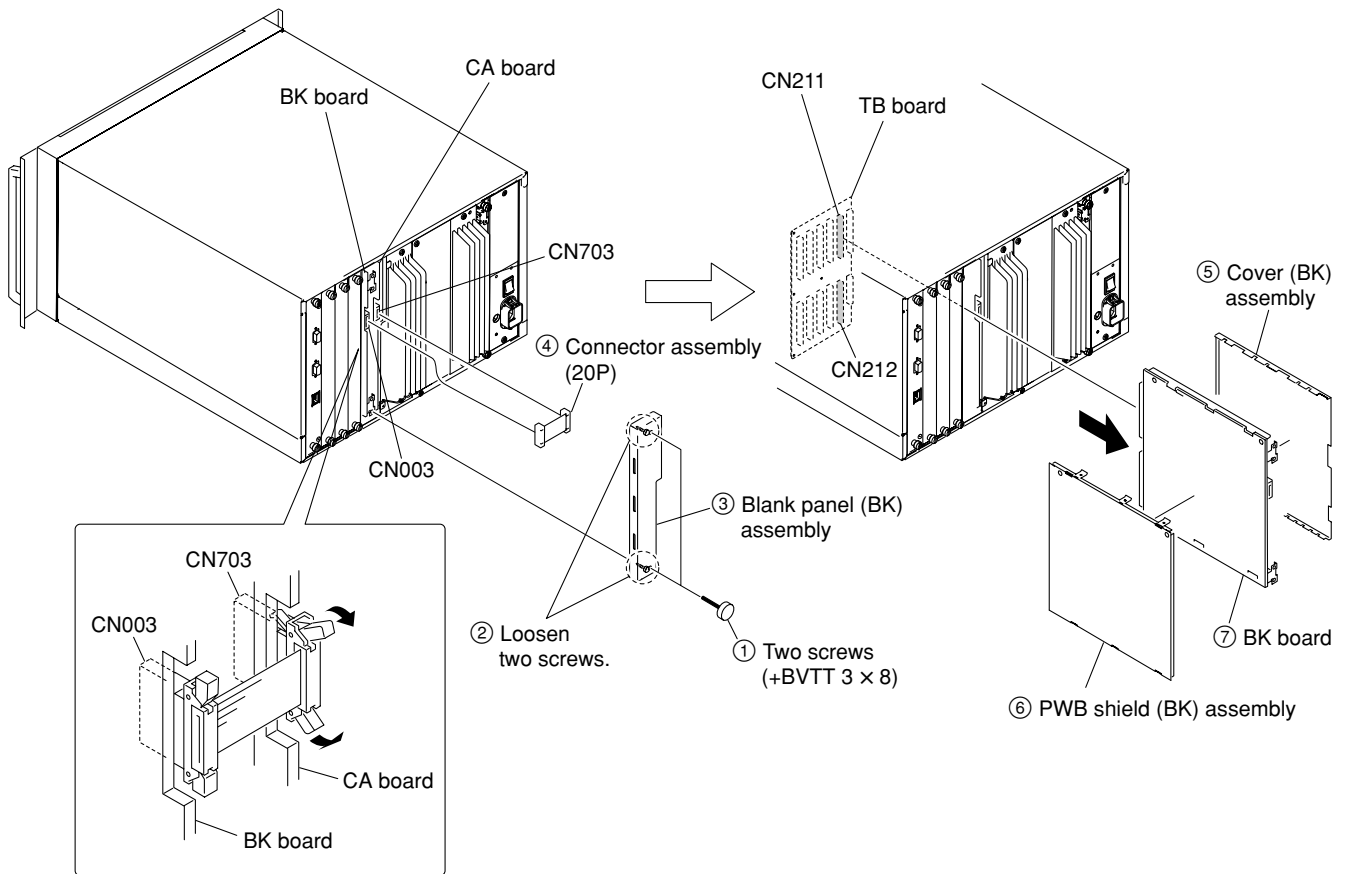

BK Board and Z Board (Extension board) (A-1091-210-A) Extension Connector

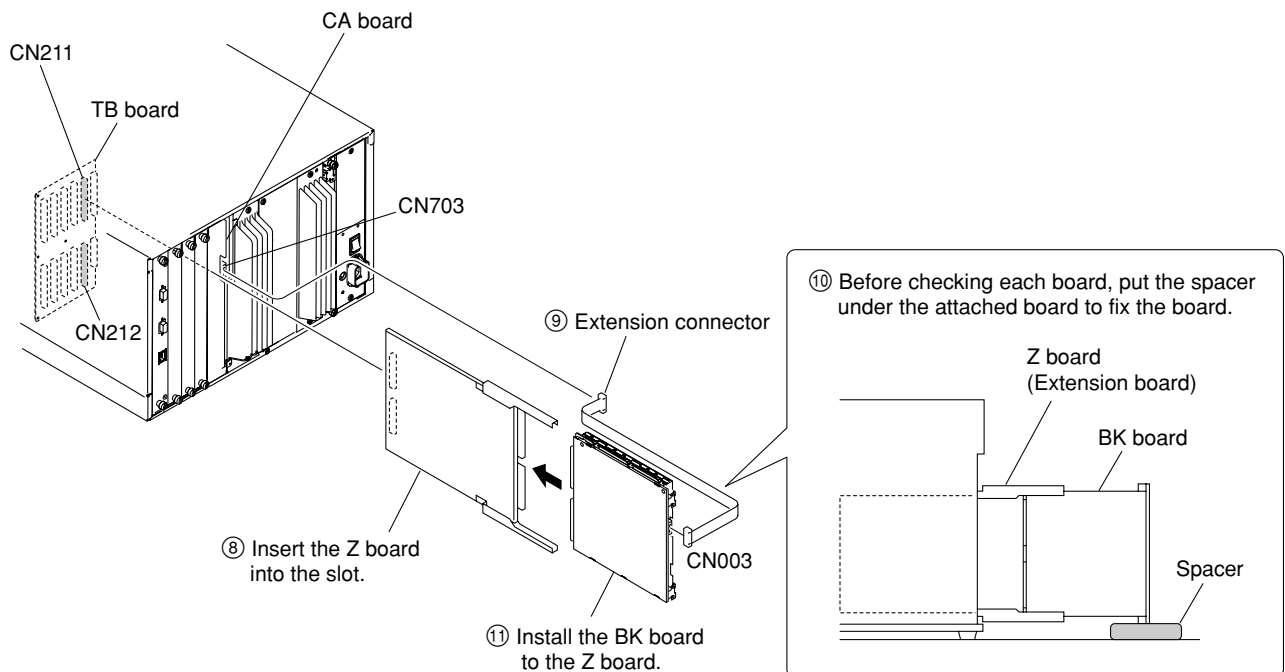

1-3-3. CA Board

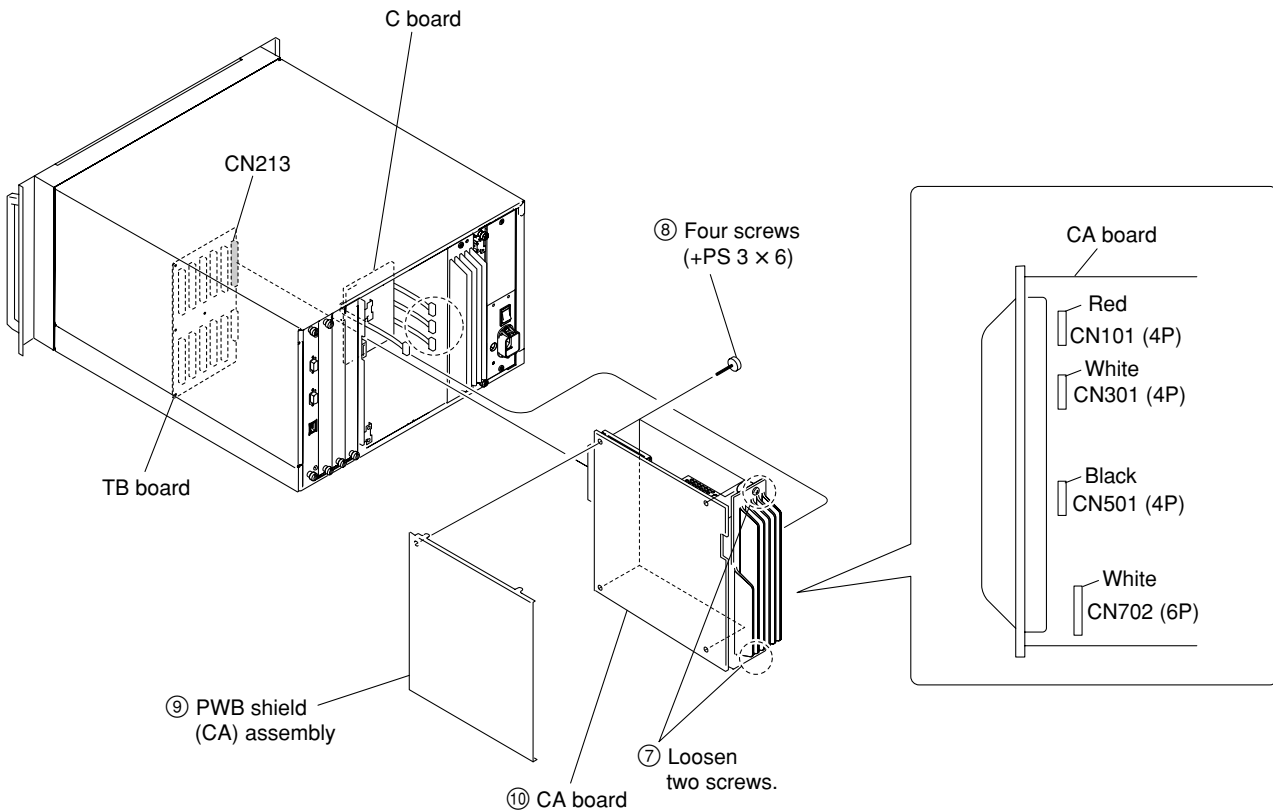
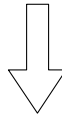
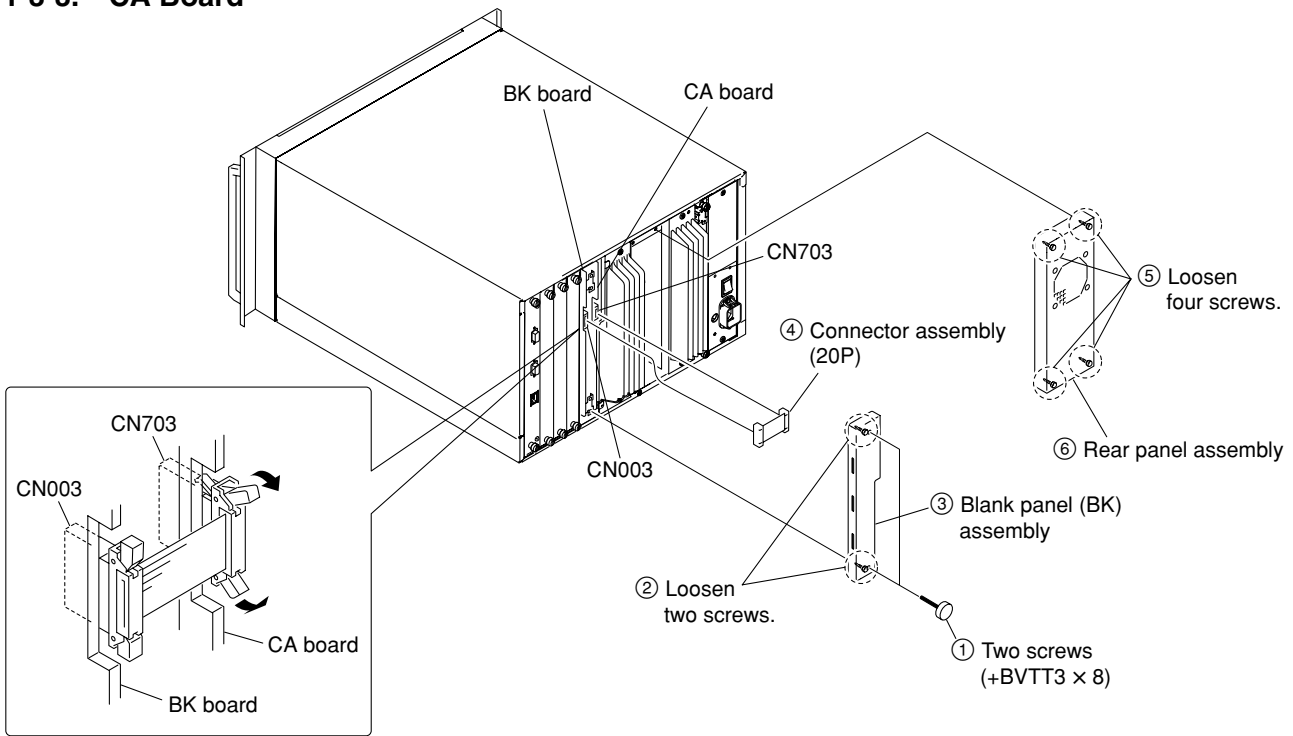

1-3-4. CA Board and ZCA Board

ZCA Board (Extension board) (A-1091-211-A) Five Extension Connectors

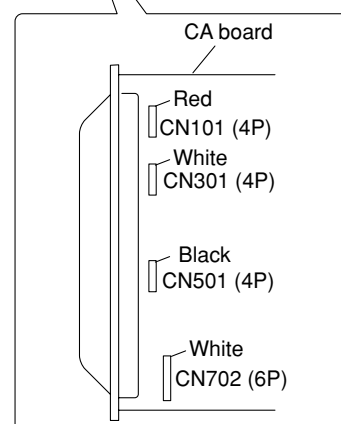
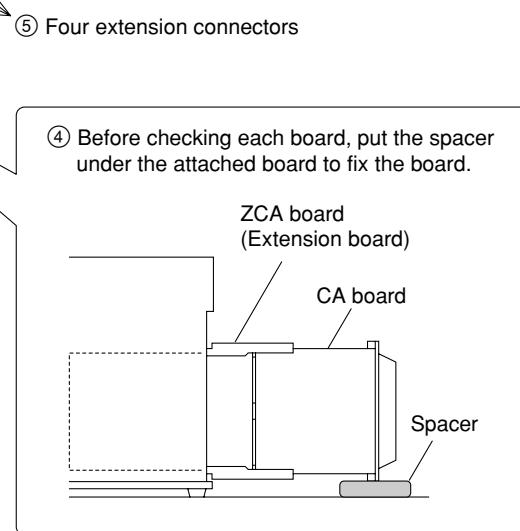
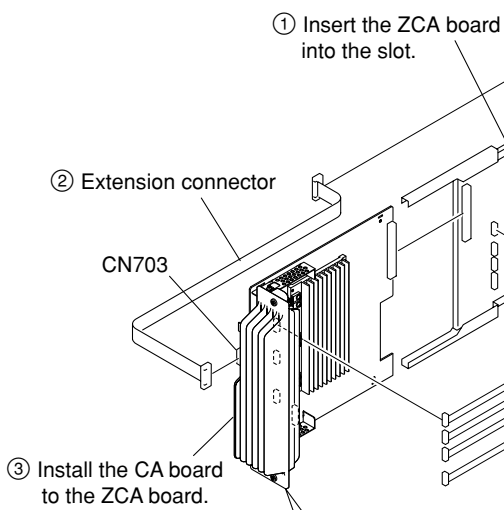
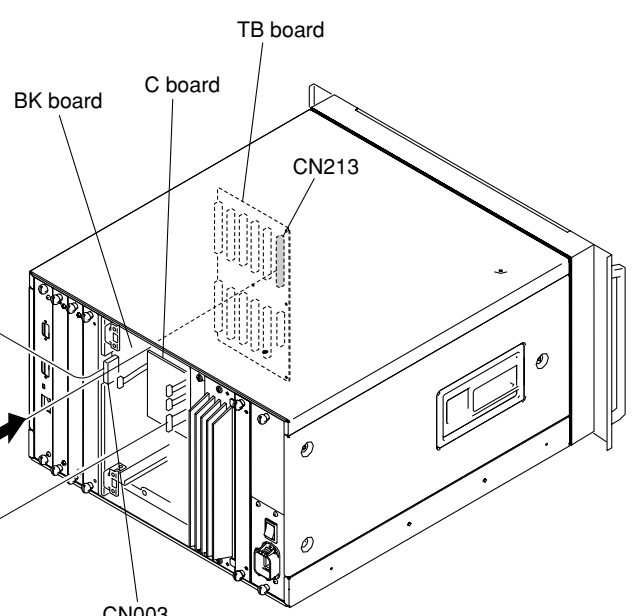
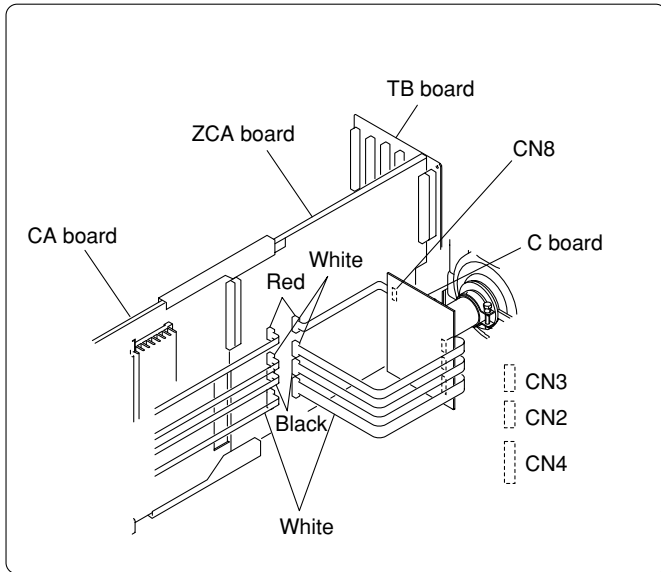

1-3-5. EA Board and E Board

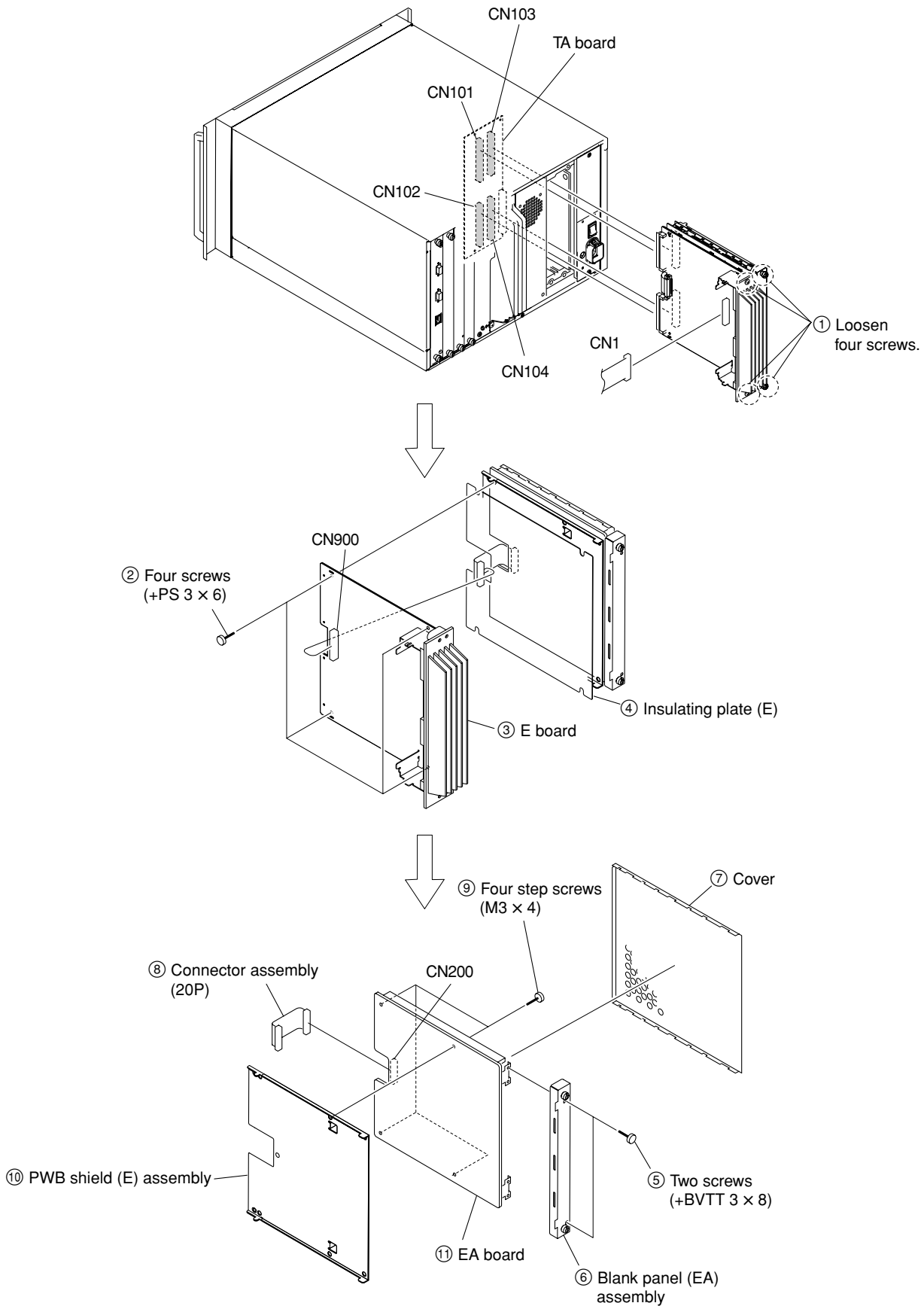

1-3-6. E Board and Z Board

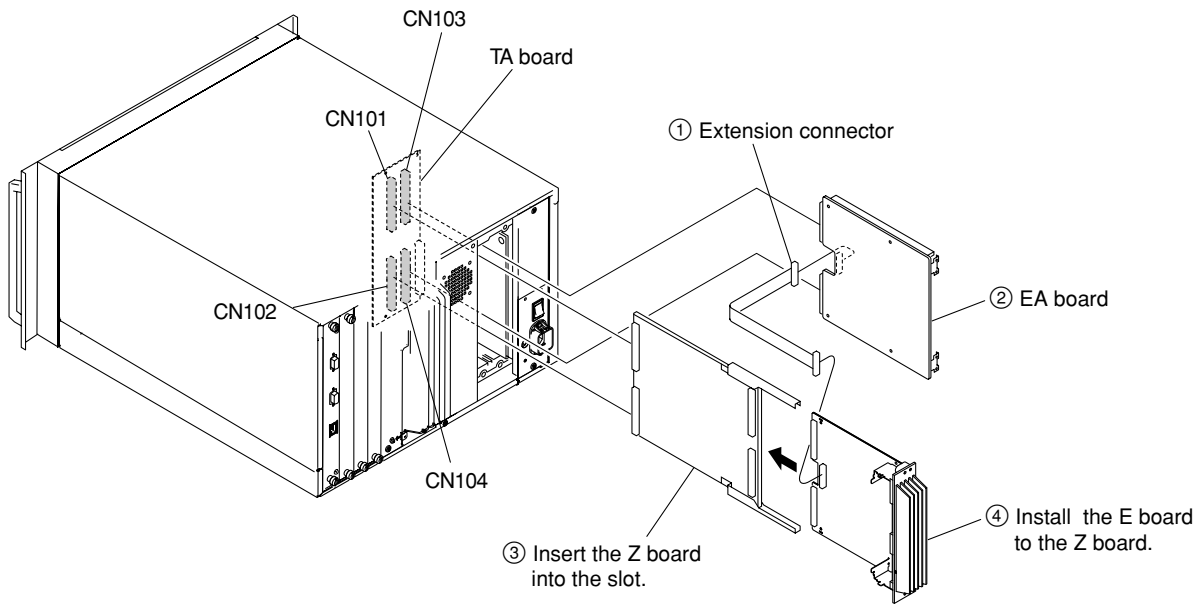

**E Board and Z Board
(Extension board) (A-1091-210-A)
Extension Connector**

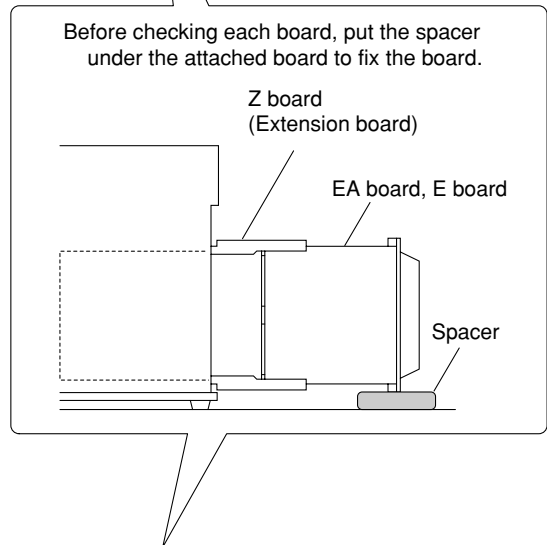

1-3-7. EA Board and Z Board

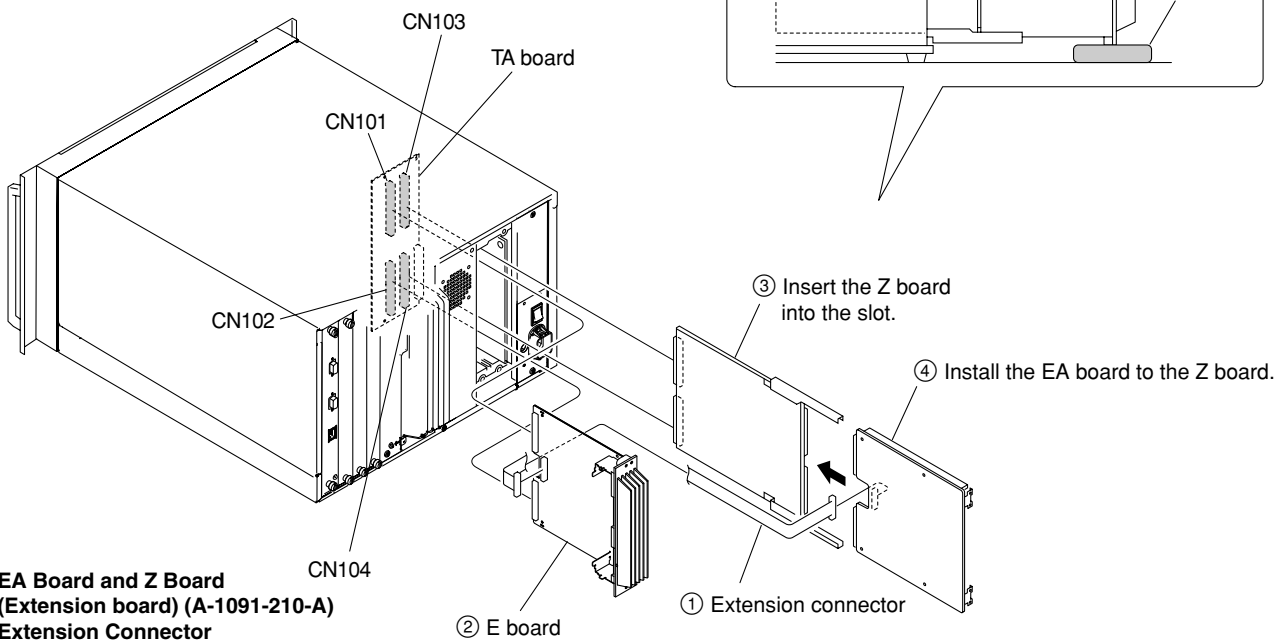

**EA Board and Z Board
(Extension board) (A-1091-210-A)
Extension Connector**

1-3-8. G Board

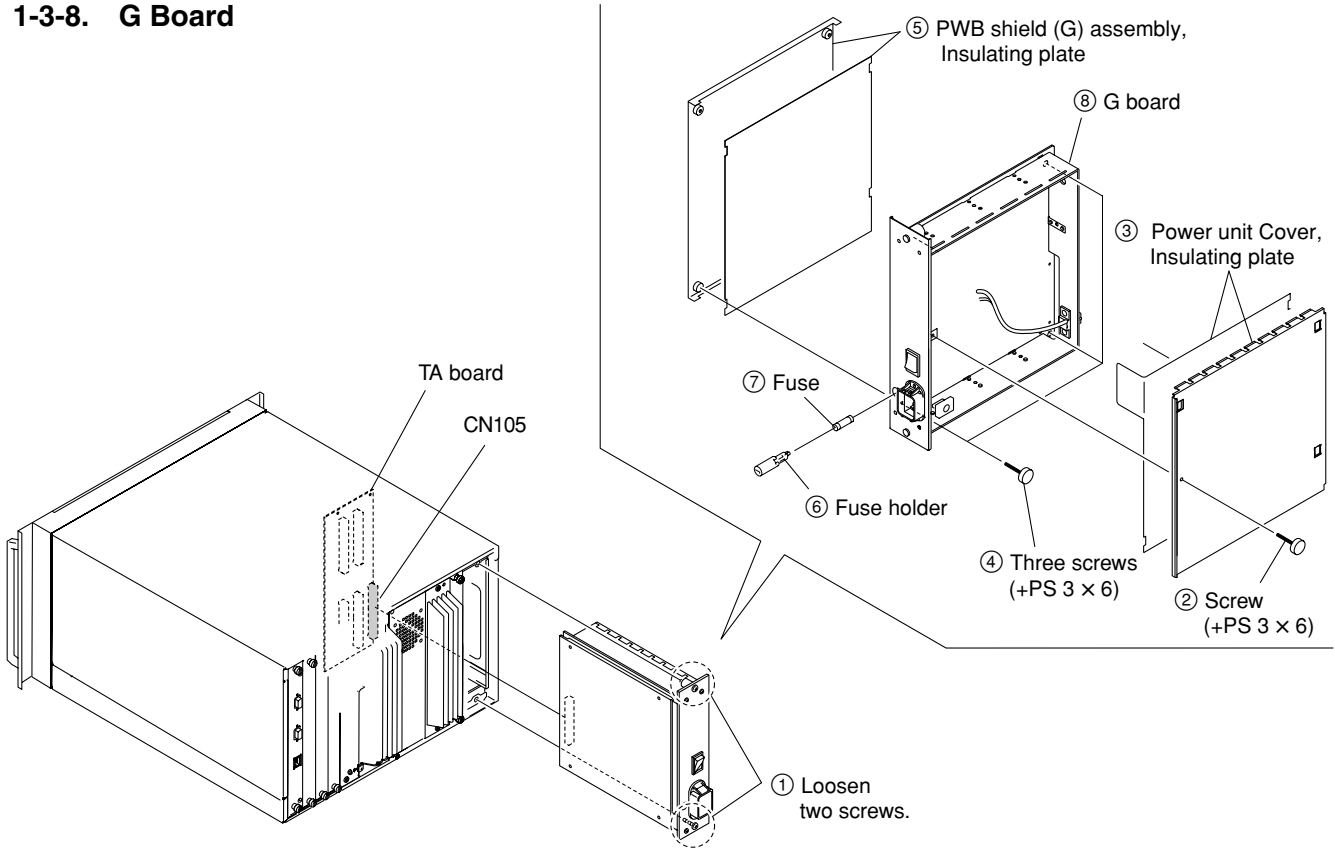

**G Board and Z Board
(Extension board) (A-1091-210-A)**

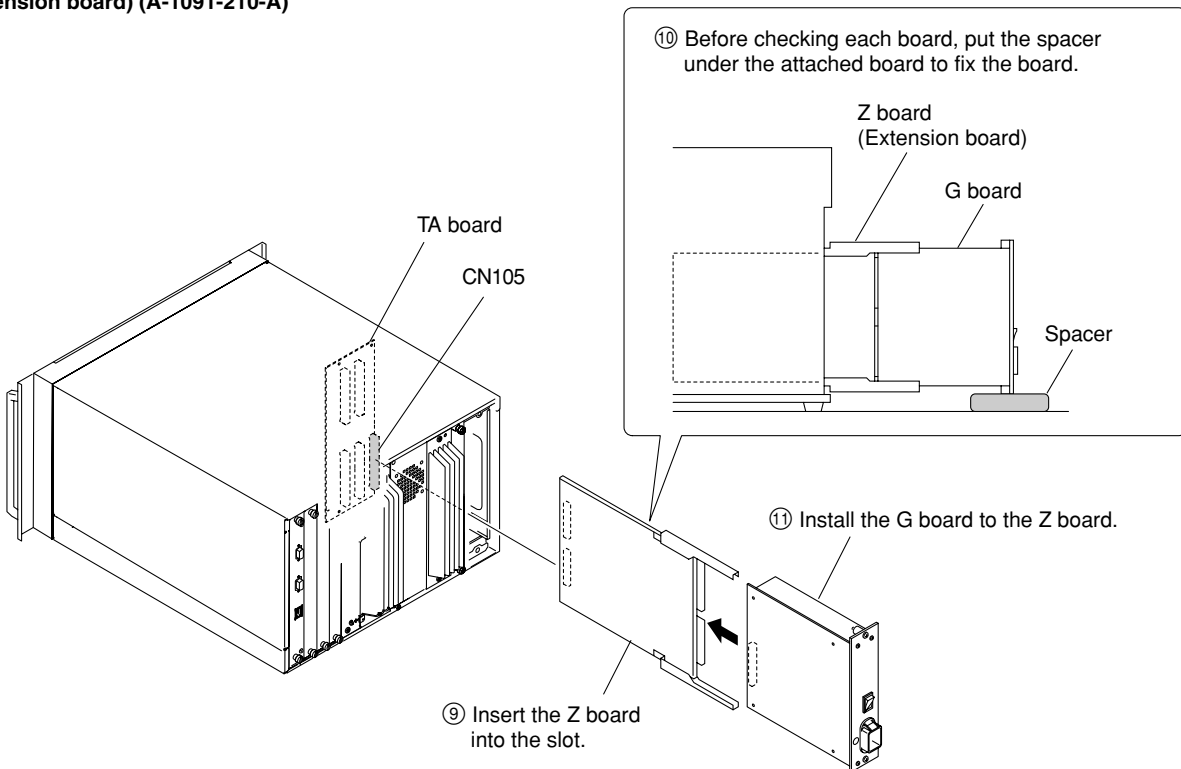

1-3-9. C Board

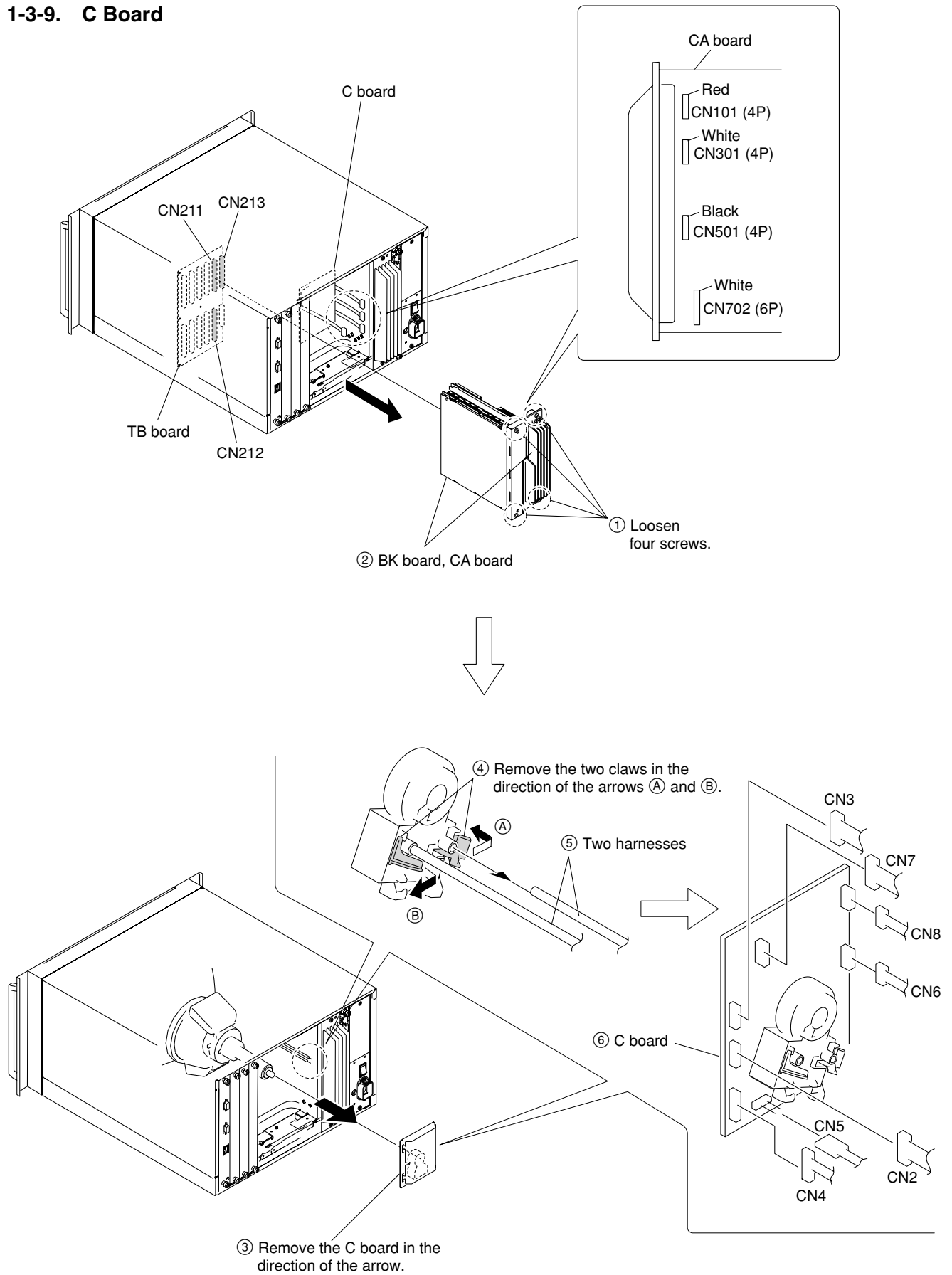

1-3-10. TA Board

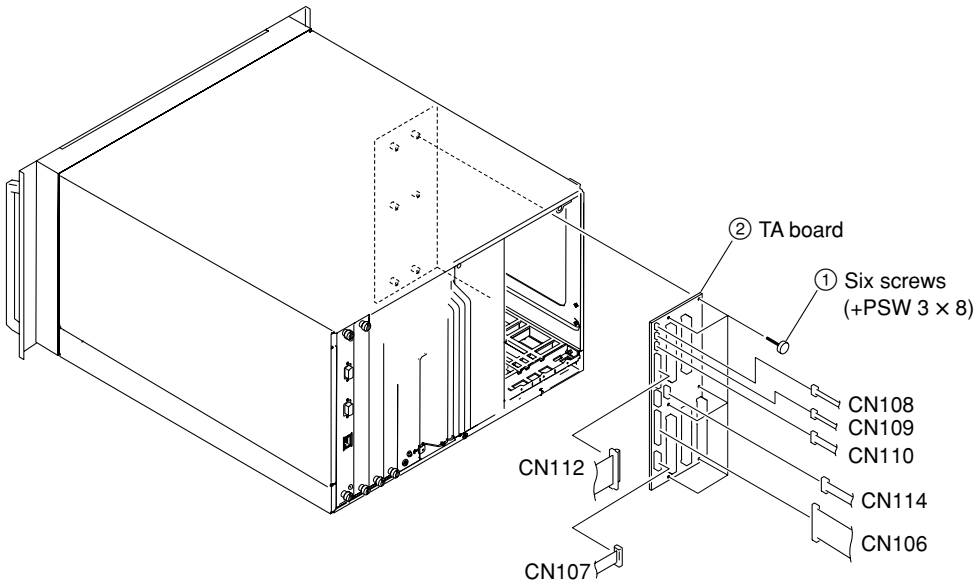

1-3-11. Cabinet

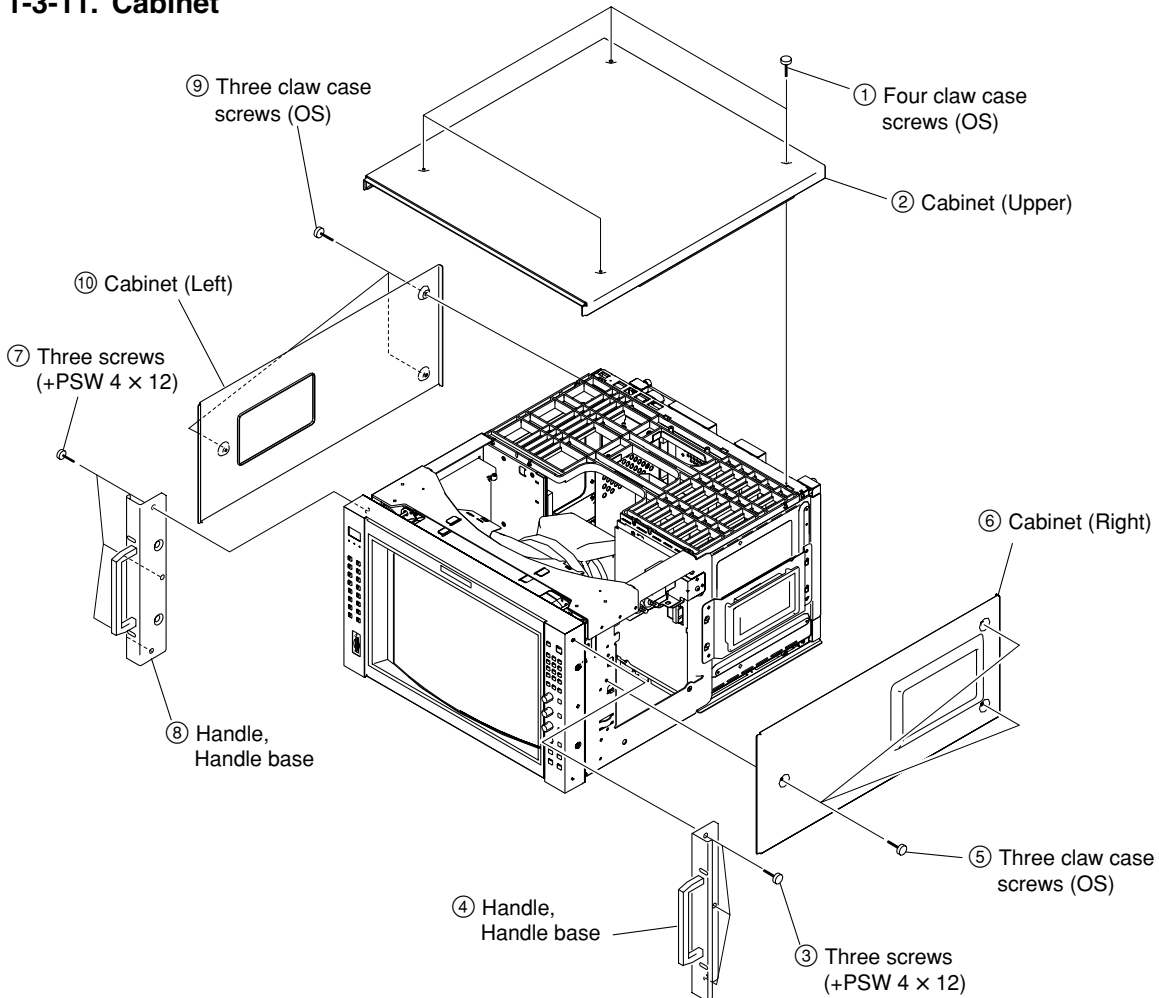

1-3-12. TB Board

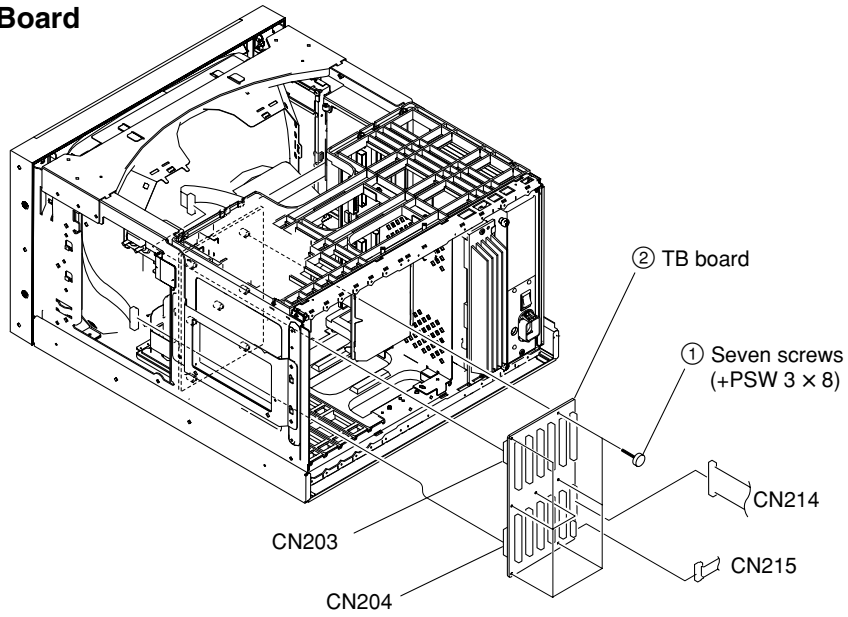

1-3-13. PA Board

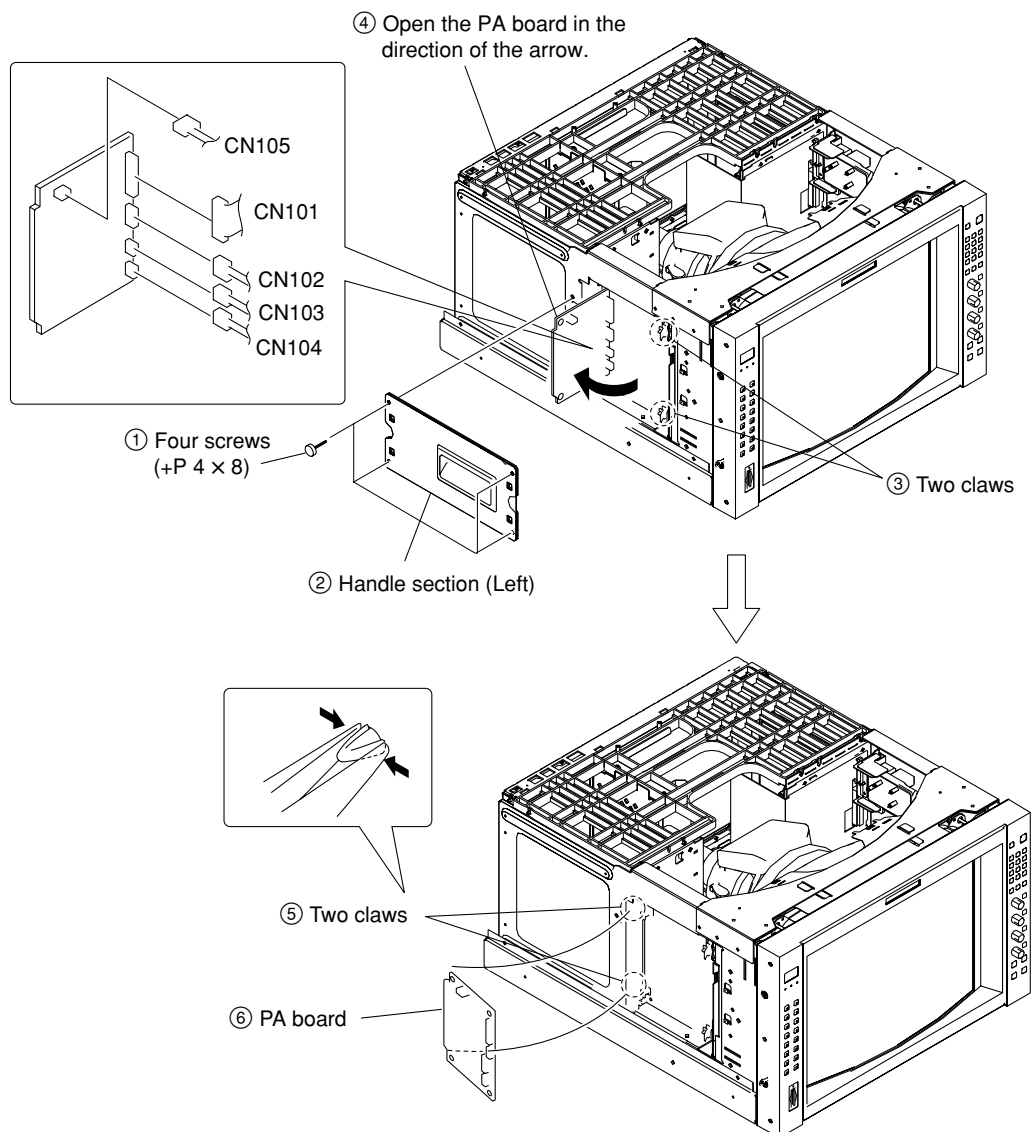

1-3-14. PC Board

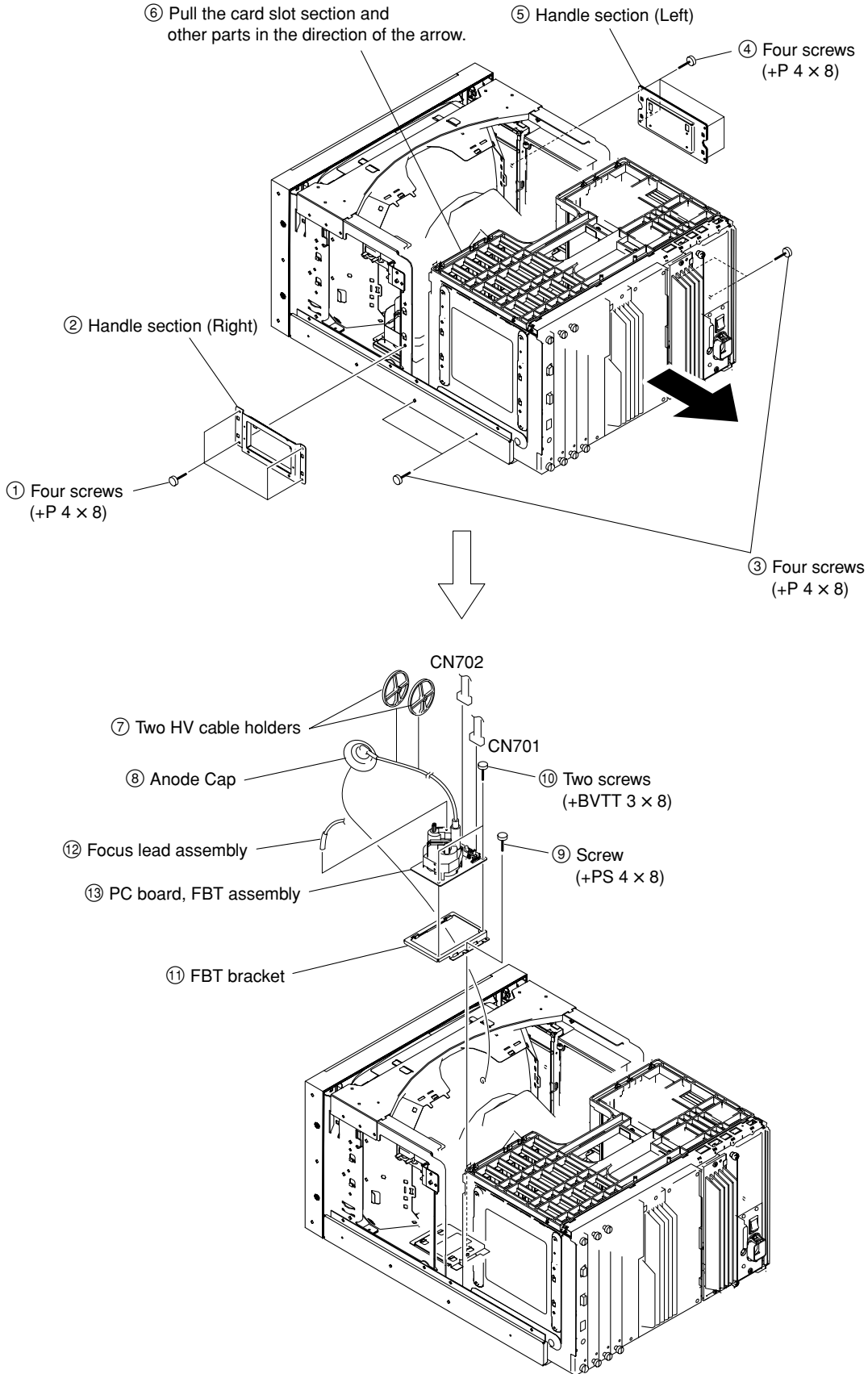

1-3-15. CRT

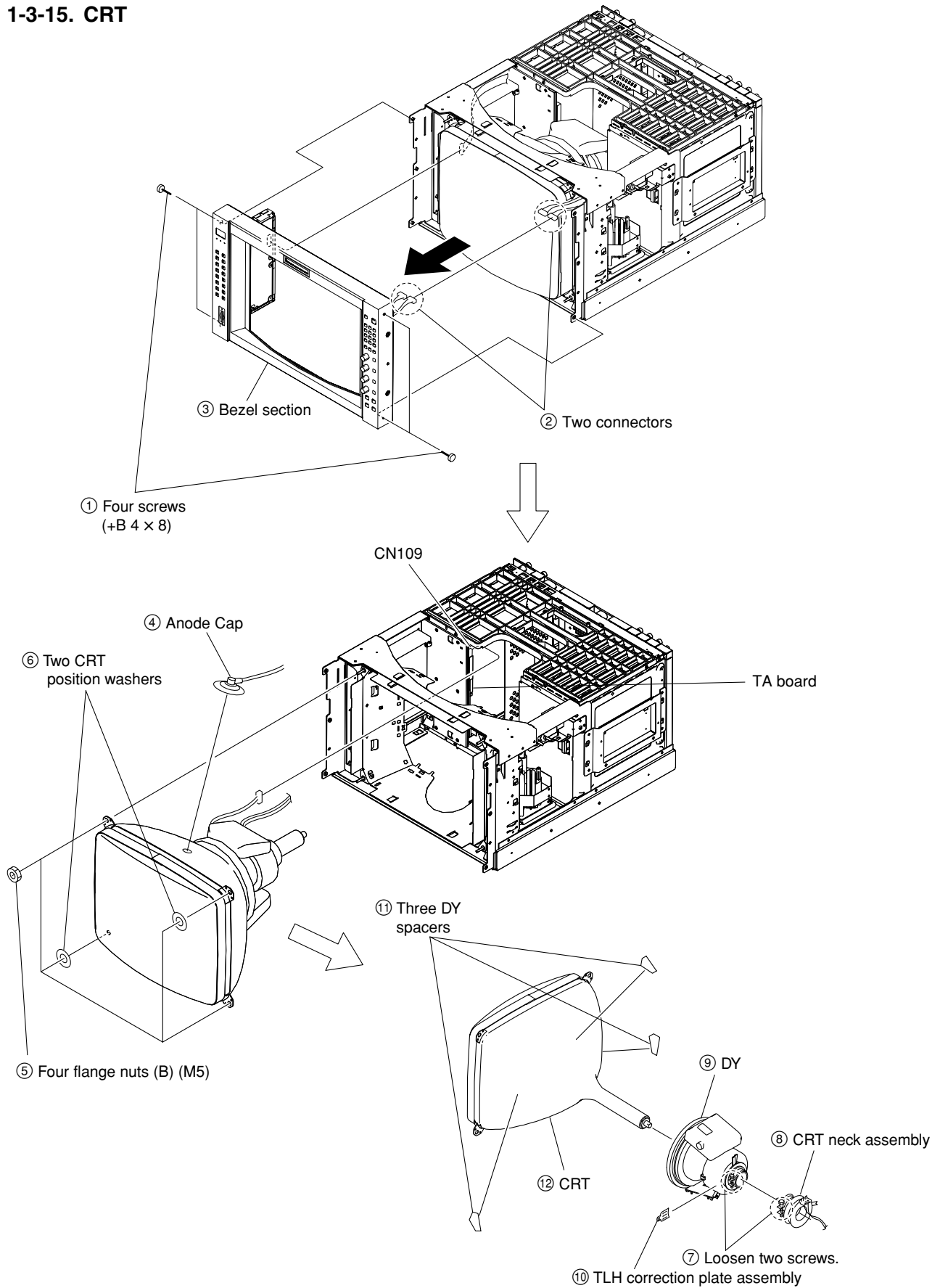

1-3-16. Bezel Assembly-1

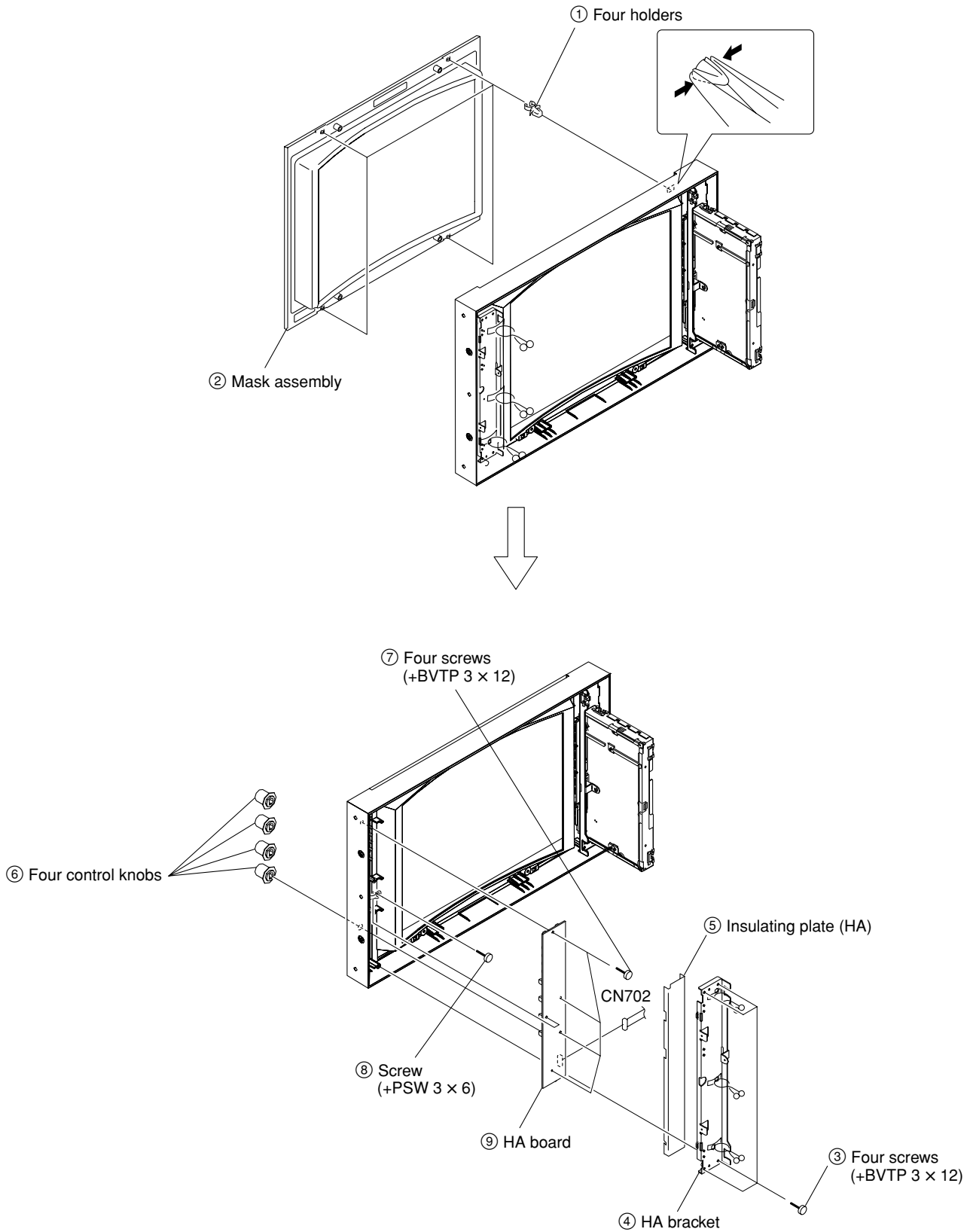

1-3-17. Bezel Assembly-2

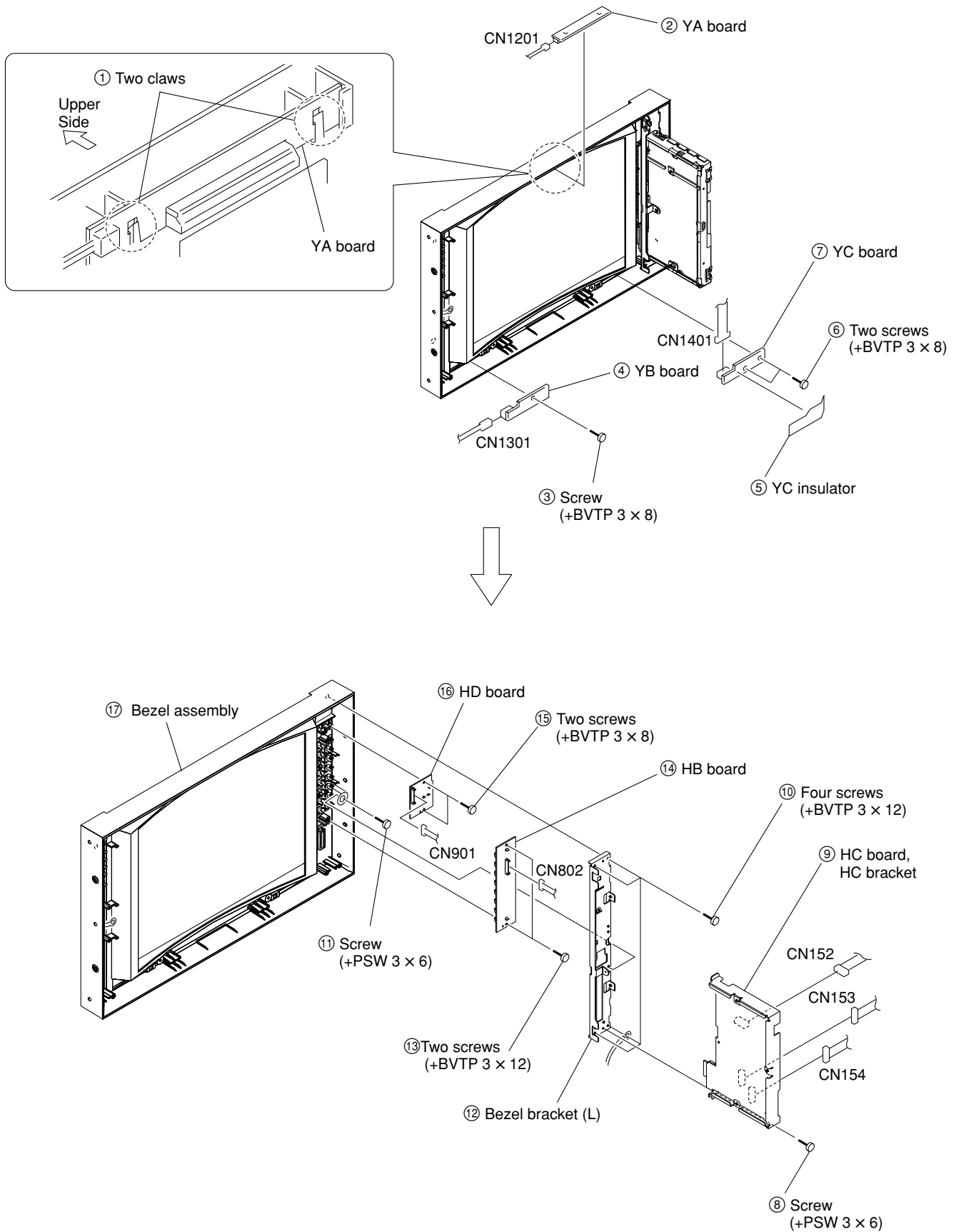

1-3-18. Anode Cap

Note

Short-circuit the anode of the CRT and the anode cap to the metal chassis, CRT shield or carbon painted on the CRT, after removing the anode.

• Removal Procedure

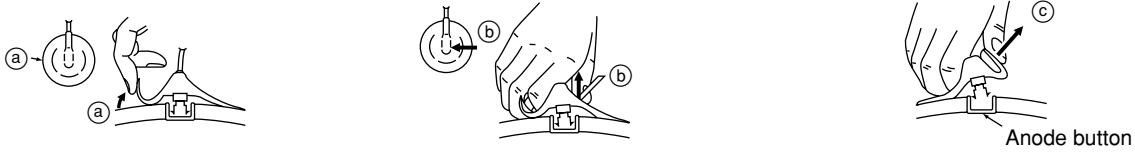

- (1) Turn up one side of the rubber cap in the direction indicated by arrow (a).
- (2) Using a thumb, pull up the rubber cap firmly in the direction indicated by arrow (b).
- (3) When one side of the rubber cap is separated from the anode button, the anode-cap can be removed by turning up the rubber cap and pulling up it in the direction of the arrow (c).

• Handling Precautions

- (1) Do not scratch the surface of anode cap with a sharp object.
- (2) Do not press the rubber so hard that it damages the inside of anode caps. A shatter-hook terminal is built into the rubber.
- (3) Do not turn the foot of the rubber over. The shatter-hook terminal will stick out or damage the rubber.

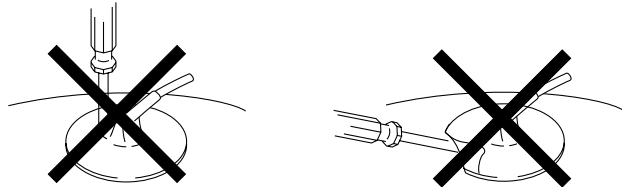

1-4. Writing and Rewriting PLD Internal Data

The BVM-A14 is equipped with a PLD (Programmable Logic Device) which can be written and rewritten using the e-Production (EPR) method.

When replacing the following parts or upgrading the PLD version, contact your local Sony Sales Office/Service Center.

Note

The part number of the PLD (or the ROM for the PLD) presented in “Spare Parts” is that of the part with no data written.

When you need to replace any part, write data in the steps on the right.

For the PLD whose program operates on the externally connected ROM, when a part in the PLD is defective, if you replace only the defective part, you do not have to rewrite the data.

About e-Production

- When writing or rewriting the PLD internal data,
 1. standard tools (cables) can be used.
 2. standard software (PLD Download Tool) can be used.
- The PLD internal data is managed on the Sony database server as a Project file (E_XXX_XXX_XX_XX).
- Standard connector (EPR connector) for writing PLD internal data on the board is equipped. “EPR” is displayed on the board.

Corresponding PLDs:

Name of board PLD/ROM	EPR connector	Project file No.
BC IC150, IC168, IC301*1	CN151	E_000_003_00_01
BK IC042, IC741*2, IC907*2	CN040	E_000_002_90_03
EA IC308*3, IC400	CN400	E_000_002_96_01
HA IC701	CN701	E_000_002_92_02
HB IC801	CN801	E_000_002_93_02
HC IC304*4	CN001	E_000_002_95_02

*1: IC301/BC is a ROM for IC300/BC.

*2: IC741, IC907/BK is a ROM for IC703, IC902/BK.

*3: IC308/EA is a ROM for IC301/EA.

*4: IC304/HC is a ROM for IC302/HC.

Devices to be used

- PLD download tool (Sony part NO.: J-7120-140-A)
Cable to connect PC and the BVM-A14.
- PC
The one with a parallel port.
The one on which the PLD Download Tool is installed.
For the supported OS and operating environment, refer to “Download Tool Operating Instruction for Device Programming”.

Operation procedure

The procedure to write data to the PLD (or the ROM for the PLD) is outlined below.

For details on these steps, refer to “Download Tool Operating Instruction for Device Programming”.

“Download Tool Operating Instruction for Device Programming” can be obtained on the same Web site where the PLD Download Tool software is downloaded.

Step 1. Prepare the Project file.

Note

Download the Project file from the Sony database server.

Step 2. With the power of the monitor turned off, connect the parallel port on the PC and the EPR connector on the target board with the PLD download tool (cable).

Step 3. Turn on the power of the monitor.

Launch the PLD Download Tool software, and import the Project file.

Step 4. Program the PLD (or the ROM for the PLD) by using the PLD Download Tool software.

Step 5. When the programming completes correctly (without an error message), restart the monitor.

Note

When the target board is extended with the Z board (extension board), be sure to remove the four short pins of connector CN106 on the Z board to make it open. Otherwise, an error may occur while writing the data.

Connector CN106 on the Z board can also be used as the EPR connector.

Section 2

Setup Adjustment

2-1. Setup Adjustment When CRT is Replaced

This section describes adjustments to be performed when the CRT has been replaced.

[Preparations]

- Required tools and measuring instruments
1. YPBPR signal generator
 - 1080/60i (1125) : SMPTE274M standard or BTA S-001 standard
 - 1035/60i (1125) : BTA S-001 standard
 - 1080/50i (1125) : SMPTE 274M standard
 - 720/60p : SMPTE 296M standard
 - 720/50p : SMPTE 296M standard
 - 480/60p (525P) : SMPTE293M standard
 - 576/50p (625) : ITU1358 standard
 - 480/60i (525) : ITU601 standard
 - 575/50i (625) : ITU601 standard
 - 1080/48i (1125) : SMPTE RP211 standard
 2. BKM-68X (analog component input adaptor)
 3. Oscilloscope
Tektronix 2465 or equivalent (that of 350-MHz band)
 4. Color analyzer (Minolta CA-100)
 5. Cables of the following specifications for connecting the CA-100 RS-232C terminal and OPTION terminal of the monitor.

- Setting the INPUT CONFIGURATION Menu
Unless specified otherwise, set the INPUT CONFIGURATION menu of the SETUP menu as follows.

```

FORMAT ..... COMPONENT
SLOT No. .... (Anywhere is OK)
SCREEN ASPECT .....
SCAN SIZE ..... NORMAL
SYNC MODE ..... INT
COLOR TEMP ..... As desired
PICTURE PRESET ..... PRESET 1
APERTURE ..... OFF
H PHASE ..... 000
  
```

BVM Option connector side CA-100 RS-232C connector side

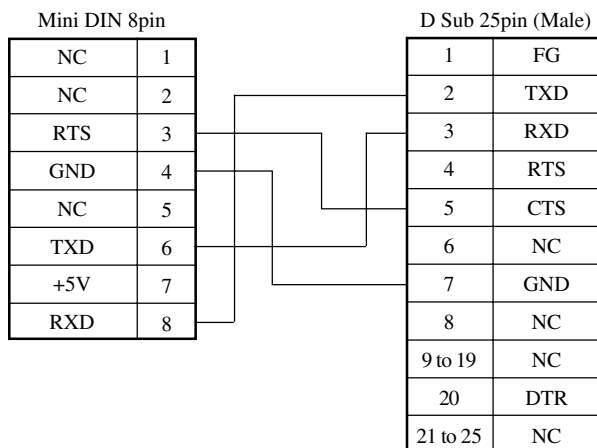

• Connection Diagram

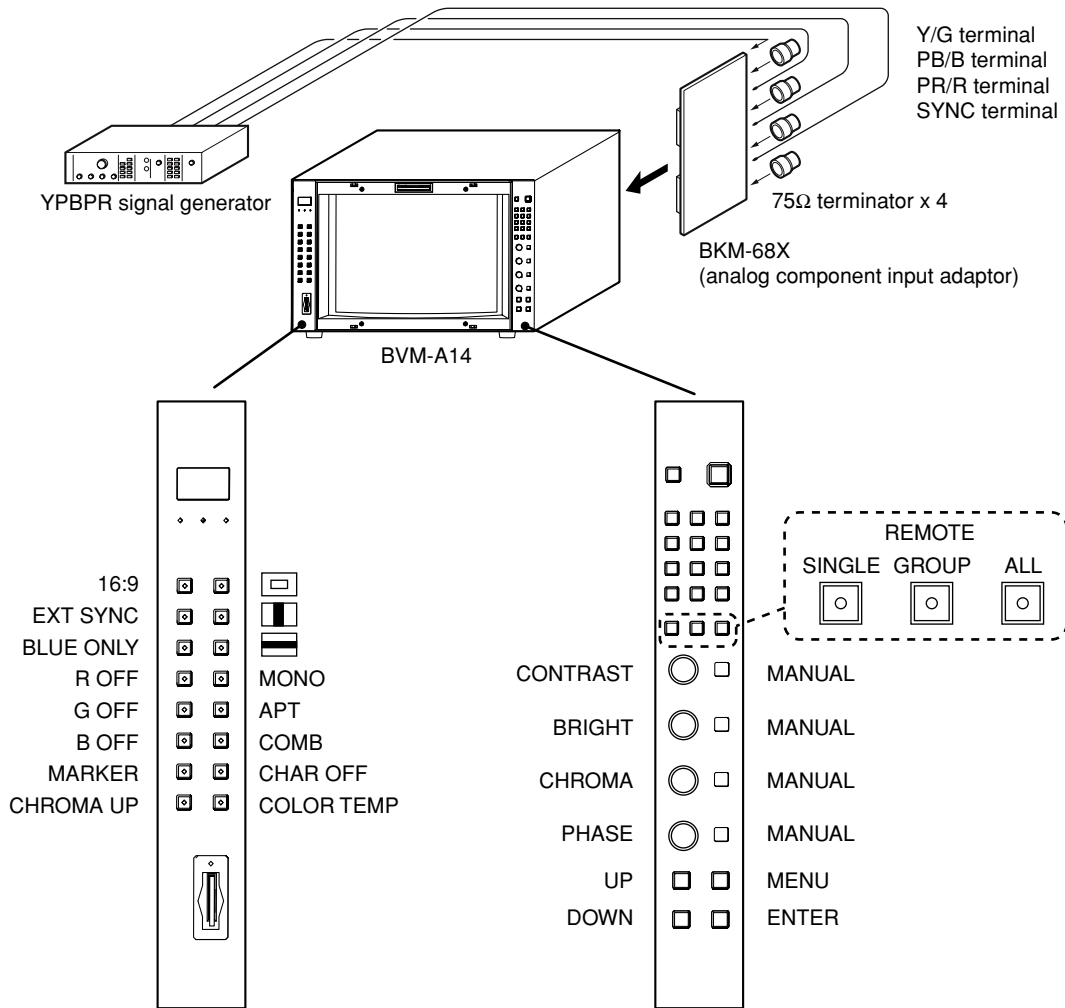

[Focus Adjustment]

1. Input the MODE9 480/60p (525p) cross-hatch signal to the BKM-68X (analog component input adaptor).
2. Press the 16 : 9 button to set 4 : 3 mode.
3. Adjust the focus at the center of the screen to be optimal using focus 1 (vertical focus adjustment) and focus 2 (horizontal focus adjustment) shown in Fig. 1-1 while balancing the three points at the left.
4. While the best focus is maintained by Focus 2 (focus tracking), the horizontal resolution better than the specifications must be visually recognized.
800 TV lines or more
5. Input the cross-hatch signal or monoscope signal for each mode in the table, and check the H/V corner focus.

If the focus is off, adjust the following items located in SYSTEM CONFIGURATION menu → MAINTENANCE menu → DEFLECTION menu (5/5).

- DF SIDE
- DF SIDE PHASE
- DF TOP
- DF BOTTOM

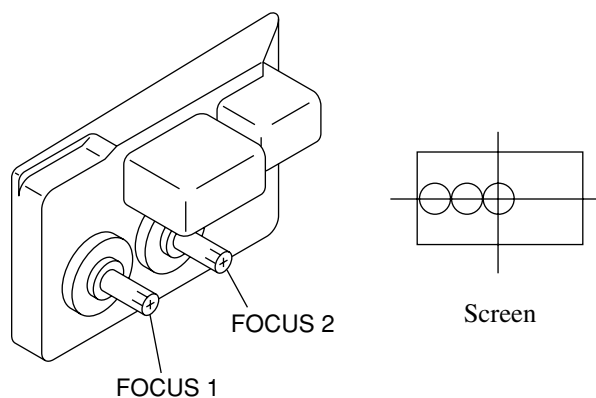

Fig. 1-1

MODE 1	1080/60i(33kHz)	16:9	NORMAL SCAN
MODE 2		16:9	UNDER SCAN
MODE 3	1035/60i(33kHz)	16:9	NORMAL SCAN
MODE 4		16:9	UNDER SCAN
MODE 5	720/60P(45kHz)	16:9	NORMAL SCAN
MODE 6		16:9	UNDER SCAN
MODE 7	480/60P(31kHz)	16:9	NORMAL SCAN
MODE 8		16:9	UNDER SCAN
MODE 9		4:3	NORMAL SCAN
MODE 10		4:3	UNDER SCAN
MODE 11	480/60i(15kHz)	16:9	NORMAL SCAN
MODE 12		16:9	UNDER SCAN
MODE 13		4:3	NORMAL SCAN
MODE 14		4:3	UNDER SCAN
MODE 15	1080/48i(27kHz)	16:9	NORMAL SCAN
MODE 16		16:9	UNDER SCAN
MODE 17	1080/50i(28kHz)	16:9	NORMAL SCAN
MODE 18		16:9	UNDER SCAN
MODE 19	720/50P(37kHz)	16:9	NORMAL SCAN
MODE 20		16:9	UNDER SCAN

MODE 21	575/50P(31kHz)	16:9	NORMAL SCAN
MODE 22		16:9	UNDER SCAN
MODE 23		4:3	NORMAL SCAN
MODE 24		4:3	UNDER SCAN
MODE 25	575/50i(15kHz)	16:9	NORMAL SCAN
MODE 26		16:9	UNDER SCAN
MODE 27		4:3	NORMAL SCAN
MODE 28		4:3	UNDER SCAN

[Landing Adjustment]

Note

Configure the following settings before adjusting the DY position:

ROTATION 128

LANDING 128

These adjustment menus are located in the SYSTEM CONFIGURATION menu → MAINTENANCE → DEFLECTION (1/5).

1. Input the MODE9 480/60p (525p) all white signal to the BKM-68X (analog component input adaptor).
2. Press the BRIGHT button and CONTRAST button to set both into the PRESET state. [The LED (green) on the button goes off.]
Press the SHIFT button and the 16 : 9 button to set 4 : 3 mode.
3. Allow the aging of 30 to 60 minutes with luminance of 100 cd/m².
4. Confirm that ROTATION that is located in the INSTALLATION SETTINGS menu → ALIGNMENT (1/3) remains in the center value 128.
5. Direct the CRT screen in the direction of east (or west). Press the DEGAUSS button.
6. Set the Purity knob in its mechanical center.

• 14-inch

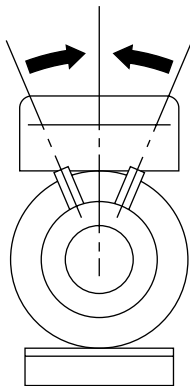
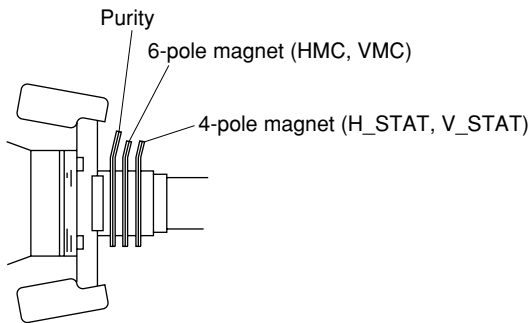

Fig. 1-2

7. Push the DY to the front as much as possible.
8. Fix the neck assembly at the position shown in Fig. 1-3.

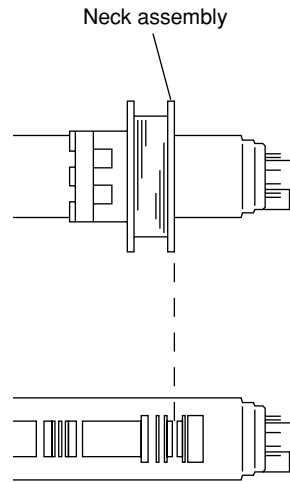

Fig. 1-3

9. Adjust the screen to green color only. Turn on the R OFF button and the B OFF button. (LED lights up)
10. Adjust the Purity knob so that green comes to the center of screen as shown in Fig. 1-4.

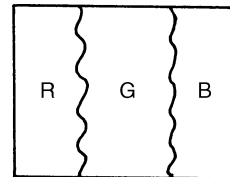

Fig. 1-4

11. Move the DY back until the whole screen becomes green only.
12. Adjust the DY tilt using the cross-hatch signal, and tighten the DY tightening screw.
13. Adjust the up/down DY twist adjustment in vertical direction while observing the vertical pin cushion signal.
14. Adjust the DY neck twist adjustment in horizontal direction while observing the horizontal trapezoidal signal.
(The adjustment sensitivity for the horizontal trapezoidal signal is very poor. Be careful not to adjust the DY inclination too excessively so as to adversely affect the convergence.)
15. Fix the deflection yoke using the four DY spacers.
(Confirm DY inclination and the DY position in the front and rear directions.)

- Final check
After the adjustment is complete, confirm that the landing error does not occur even the BVM monitor is directed in all directions of east, west, north and south.

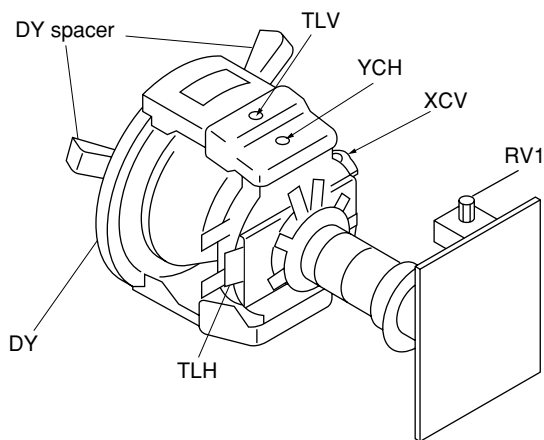

Fig. 1-5

[H Blanking Adjustment] (UNDER SCAN)

Note

The following adjustment menus are located in the SYSTEM CONFIGURATION menu → MAINTENANCE → DEFLECTION (1/5) (2/5).

H BLK LEFT
H BLK RIGHT
H CENTER
H PHASE
H SIZE SW
H SIZE

• 1080/60i (33 kHz) 16:9 UNDER SCAN mode H blanking adjustment

1. Press the UNDER SCAN button to set 16:9 UNDER SCAN.
2. Input the MODE1 1080/60i (1125) cross-hatch signal.
3. Adjust the H. BLK. LEFT data and the H. BLK. RIGHT data to the minimum (0).
4. Adjust the BRIGHT to the maximum.
5. Turn the H SIZE SW in the menu to ON. Adjust H SIZE so that the right and left sides of the raster can be completely displayed. (Adjust A and A' in Fig. 1-6 to about 10 mm.)
6. Adjust the H. CENTER data so that the raster area comes to the center of the effective screen (so that A and A' are almost equal). (Fig. 1-6) When this adjustment is complete, take note of the H. CENTER adjustment data.
7. Adjust the H. PHASE data so that the signal area comes to the center of the raster area (so that B and B' are almost equal). (Fig. 1-6) When this adjustment is complete, take note of the H. PHASE data.
8. Adjust the H. BLK. LEFT data so that the left-most end of the raster area is positioned at 2.0 mm outside the left-most end of the crosshatch signal area. (Fig. 1-7.) When this adjustment is complete, take note of the H. BLK. LEFT adjustment data.
9. Adjust the H. BLK. RIGHT data so that the right-most end of the raster area is positioned at 2.0 mm outside the right-most end of the crosshatch signal area. (Fig. 1-7.) When this adjustment is complete, take note of the H. BLK. RIGHT adjustment data.
10. Set the H SIZE SW in the menu to OFF, and return the H SIZE to the original value.
11. Check the center of the image (image phase). If it is misaligned, repeat steps 5 to 10.
12. Set BRIGHT to the normal position.
13. H CENTER
H PHASE
H BLK LEFT
H BLK RIGHT
Copy the above-described data to the following modes.

MODE4	1035/60i (33kHz)	16:9	UNDER SCAN
-------	------------------	------	------------

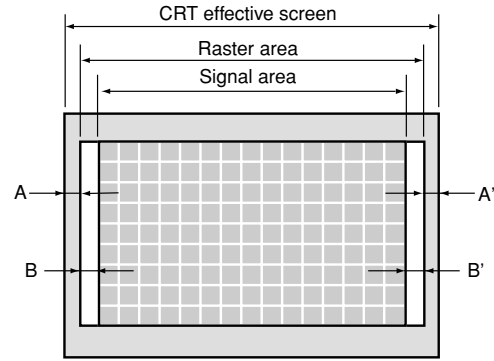

Fig. 1-6

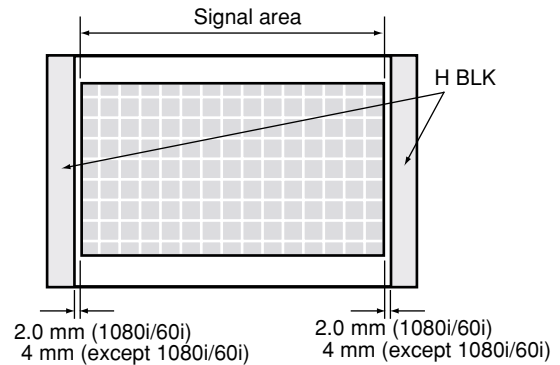

Fig. 1-7

• 720/60p (45 kHz) 16:9 UNDER SCAN mode H blanking adjustment

1. Press the UNDER SCAN button to set 16:9 UNDER SCAN.
2. Connect the MODE5 720/60P cross-hatch signal to the input.
3. Adjust the H. BLK. LEFT data and the H. BLK. RIGHT data to the minimum (0).
4. Adjust the BRIGHT to the maximum.
5. Turn the H SIZE SW in the menu to ON. Adjust H SIZE so that the right and left sides of the raster can be completely displayed.
6. Adjust the H. PHASE data so that the signal area comes to the center of the effective screen (so that B and B' are almost equal). (Fig. 1-6) When this adjustment is complete, take note of the H. PHASE data.
7. Adjust the H. BLK. LEFT data so that the left-most end of the raster area is positioned at 4mm outside the left-most end of the crosshatch signal area. (Fig. 1-7.) When this adjustment is complete, take note of the H. BLK. LEFT adjustment data.
8. Adjust the H. BLK. RIGHT data so that the right-most end of the raster area is positioned at 4mm outside the right-most end of the crosshatch signal area. (Fig. 1-7.) When this adjustment is complete, take note of the H. BLK. RIGHT adjustment data.
9. Set the H SIZE SW in the menu to OFF, and return the H SIZE to the original value.
10. Check the center of the image (image phase). If it is misaligned, repeat steps 5 to 9.
11. Set BRIGHT to the normal position.

- 480/60p (31 kHz) 16:9 UNDER SCAN mode H blanking adjustment

1. Adjust the H. CENTER, H. PHASE, H. BLK. LEFT and H. BLK. RIGHT data in the same manner as steps 3 to 11 in the 1080/60i (33 kHz) 16:9 UNDER SCAN mode.
2. H CENTER
H PHASE
H BLK LEFT
H BLK RIGHT

Copy the above-described data to the following modes.

MODE10	480/60p (31kHz)	4:3	UNDER SCAN
--------	-----------------	-----	------------

- 480/60i (15 kHz) 16:9 UNDER SCAN mode H blanking adjustment

1. Adjust the H. CENTER, H. PHASE, H. BLK. LEFT and H. BLK. RIGHT data in the same manner as steps 3 to 11 in the 1080/60i (33 kHz) 16:9 UNDER SCAN mode.
2. H CENTER
H PHASE
H BLK LEFT
H BLK RIGHT

Copy the above-described data to the following modes.

MODE14	480/60i (15kHz)	4:3	UNDER SCAN
--------	-----------------	-----	------------

- 576/50p (31 kHz) 16:9 UNDER SCAN mode H blanking adjustment

1. Adjust the H. CENTER, H. PHASE, H. BLK. LEFT and H. BLK. RIGHT data in the same manner as steps 3 to 11 in the 1080/60i (33 kHz) 16:9 UNDER SCAN mode.
2. H CENTER
H PHASE
H BLK LEFT
H BLK RIGHT

Copy the above-described data to the following modes.

MODE24	576/50p (31kHz)	4:3	UNDER SCAN
--------	-----------------	-----	------------

- 575/50i (15 kHz) 16:9 UNDER SCAN mode H blanking adjustment

1. Adjust the H. CENTER, H. PHASE, H. BLK. LEFT and H. BLK. RIGHT data in the same manner as steps 3 to 11 in the 1080/60i (33 kHz) 16:9 UNDER SCAN mode.
2. H CENTER
H PHASE
H BLK LEFT
H BLK RIGHT

Copy the above-described data to the following modes.

MODE28	575/50i (15kHz)	4:3	UNDER SCAN
--------	-----------------	-----	------------

- 720/60p (45 kHz) 16:9 UNDER SCAN mode H blanking adjustment

1. Adjust the H. CENTER, H. PHASE, H. BLK. LEFT and H. BLK. RIGHT data in the same manner as steps 3 to 11 of the 1080/60i (33 kHz) 16:9 NORMAL mode.

- 720/50p (37 kHz) 16:9 UNDER SCAN mode H blanking adjustment

1. Adjust the H. CENTER, H. PHASE, H. BLK. LEFT and H. BLK. RIGHT data in the same manner as steps 3 to 11 of the 1080/60i (33 kHz) 16:9 NORMAL mode.

- 1080/48i (27 kHz) 16:9 UNDER SCAN mode H blanking adjustment

1. Adjust the H. CENTER, H. PHASE, H. BLK. LEFT and H. BLK. RIGHT data in the same manner as steps 3 to 11 in the 1080/60i (33 kHz) 16:9 UNDER mode.

- 1080/50i (28 kHz) 16:9 UNDER SCAN mode H blanking adjustment

1. Adjust the H. CENTER, H. PHASE, H. BLK. LEFT and H. BLK. RIGHT data in the same manner as steps 3 to 11 in the 1080/60i (33 kHz) 16:9 UNDER SCAN mode.

[H Blanking Adjustment] (NORMAL SCAN)

Note

The following adjustment menus are located in the SYSTEM CONFIGURATION menu → MAINTENANCE → DEFLECTION (1/5) (2/5).

H BLK LEFT
H BLK RIGHT
H CENTER
H PHASE
H SIZE SW
H SIZE

- 1080/60i (33 kHz) 16:9 NORMAL mode H blanking adjustment
- 1. Press the UNDER SCAN button to set 16:9 NORMAL SCAN.
- 2. Input the MODE1 1080/60i (1125) cross-hatch signal.
- 3. Adjust the H. BLK. LEFT data and the H. BLK. RIGHT data to the minimum (0).
- 4. Adjust the BRIGHT to the maximum.
- 5. Turn the H SIZE SW in the menu to ON. Adjust H SIZE so that the right and left sides of the raster can be completely displayed. (Adjust A and A' in Fig. 1-6 to about 10 mm.)
- 6. Adjust the H. CENTER data so that the raster area comes to the center of the effective screen (so that A and A' are almost equal). (Fig. 1-6)
When this adjustment is complete, take note of the H. CENTER adjustment data.
- 7. Adjust the H. PHASE data so that the signal area comes to the center of the raster area (so that B and B' are almost equal). (Fig. 1-6)
When this adjustment is complete, take note of the H. PHASE data.
- 8. Set the H SIZE SW in the menu to OFF, and return the H SIZE to the original value.
- 9. Adjust the H BLK LEFT data so that the left edge of the raster area comes outside of the left edge of the cross-hatch signal area just before the effective screen. Write the data calculated by subtracting ten steps from that register to H BLK LEFT.
- 10. Adjust the H BLK RIGHT data so that the right edge of the raster area comes outside of the right edge of the cross-hatch signal area just before the effective screen. Write the data calculated by subtracting ten steps from that register to H BLK RIGHT.
- 11. Check the center of the image (image phase). If it is misaligned, repeat steps 5 to 10.
- 12. H CENTER
H PHASE
H BLK LEFT
H BLK RIGHT
Copy the above-described data to the following modes.
- 13. Set BRIGHT to the normal position.

MODE3	1035/60i (33kHz)	16:9	NORMAL
-------	------------------	------	--------

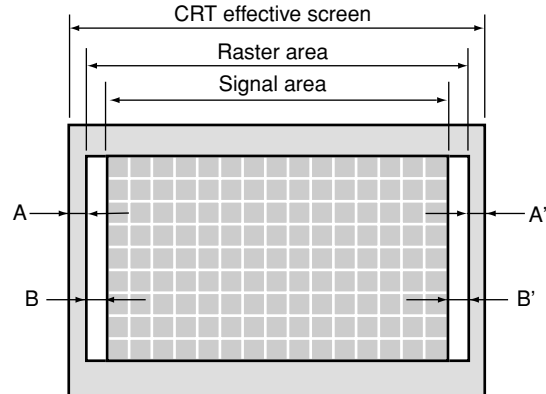

Fig. 1-6

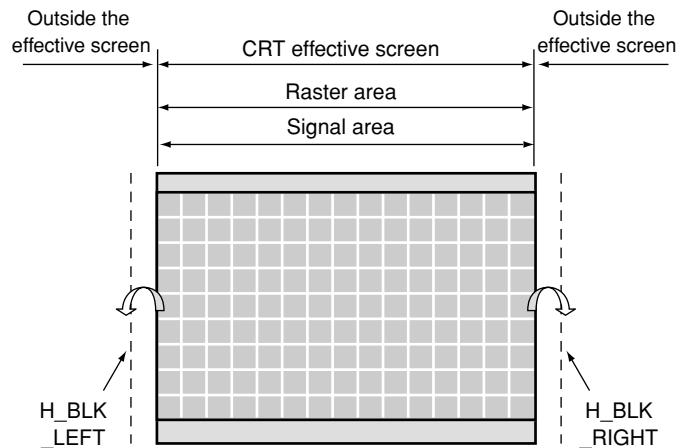

Fig. 1-7

- 480/60p (31 kHz) 16:9 NORMAL mode H blanking adjustment
 1. Adjust the H. CENTER, H. PHASE, H. BLK. LEFT and H. BLK. RIGHT data in the same manner as steps 3 to 11 of the 1080/60i (33 kHz) 16:9 NORMAL mode.
 2. H CENTER
H PHASE
H BLK LEFT
H BLK RIGHT

Copy the above-described data to the following modes.

MODE10	480/60p (31kHz)	4:3	NORMAL
--------	-----------------	-----	--------

- 480/60i (15 kHz) 16:9 NORMAL mode H blanking adjustment
 1. Adjust the H. CENTER, H. PHASE, H. BLK. LEFT and H. BLK. RIGHT data in the same manner as steps 3 to 11 of the 1080/60i (33 kHz) 16:9 NORMAL mode.
 2. H CENTER
H PHASE
H BLK LEFT
H BLK RIGHT

Copy the above-described data to the following modes.

MODE13	480/60i (15kHz)	16:9	NORMAL
--------	-----------------	------	--------

- 576/50p (31 kHz) 16:9 NORMAL mode H blanking adjustment
 1. Adjust the H. CENTER, H. PHASE, H. BLK. LEFT and H. BLK. RIGHT data in the same manner as steps 3 to 11 of the 1080/60i (33 kHz) 16:9 NORMAL mode.
 2. H CENTER
H PHASE
H BLK LEFT
H BLK RIGHT

Copy the above-described data to the following modes.

MODE23	576/50p (31kHz)	16:9	NORMAL
--------	-----------------	------	--------

- 575/50i (15kHz) 16:9 NORMAL mode H blanking adjustment
 1. Adjust the H. CENTER, H. PHASE, H. BLK. LEFT and H. BLK. RIGHT data in the same manner as steps 3 to 11 of the 1080/60i (33 kHz) 16:9 NORMAL mode.
 2. H CENTER
H PHASE
H BLK LEFT
H BLK RIGHT

Copy the above-described data to the following modes.

MODE27	575/50i (15kHz)	16:9	NORMAL
--------	-----------------	------	--------

- 720/60p (45 kHz) 16:9 NORMAL mode H blanking adjustment
 1. Adjust the H. CENTER, H. PHASE, H. BLK. LEFT and H. BLK. RIGHT data in the same manner as steps 3 to 11 of the 1080/60i (33 kHz) 16:9 NORMAL mode.
- 720/50p (37 kHz) 16:9 NORMAL mode H blanking adjustment
 1. Adjust the H. CENTER, H. PHASE, H. BLK. LEFT and H. BLK. RIGHT data in the same manner as steps 3 to 11 of the 1080/60i (33 kHz) 16:9 NORMAL mode.

- 1080/48i (27 kHz) 16:9 NORMAL mode H blanking adjustment
 1. Adjust the H. CENTER, H. PHASE, H. BLK. LEFT and H. BLK. RIGHT data in the same manner as steps 3 to 11 of the 1080/60i (33 kHz) 16:9 NORMAL mode.
- 1080/50i (28 kHz) 16:9 NORMAL mode H blanking adjustment
 1. Adjust the H. CENTER, H. PHASE, H. BLK. LEFT and H. BLK. RIGHT data in the same manner as steps 3 to 11 of the 1080/60i (33 kHz) 16:9 NORMAL mode.

[Linearity Adjustment]

Note

The following adjustment menus are located in the SYSTEM CONFIGURATION menu → MAINTENANCE → DEFLECTION (1/5) (2/5) (3/5).

H SIZE
H CENTER
H PHASE
V SIZE
V CENTER
H LIN BAL
H LIN TOP
H LIN BOTTOM
V LIN AMP
V LIN BAL
H PIN
H PIN BAL
H KEY
H KEY BAL
H CORNER PIN
H CORNER S

1. Input the MODE1 1080/60i (1125) cross-hatch signal.
2. Set SCREEN MODE to 16:9 NORM.
3. Confirm that there exists no DY inclination, no V PIN cushion distortion in the top and bottom and no horizontal trapezoidal distortions on screen.
DY inclination : Adjust the DY inclination
V PIN cushion distortion in the top and bottom:
DY up/down neck twist
Horizontal trapezoidal distortion :
Adjust with TLV VR of DY.
(If they are adjusted extremely, the convergence can be adversely affected. In such a case, select the green single color for this adjustment.)
4. Input the MODE1 1080/60i (1125) monoscope signal.
5. Adjust the H CENTER data and adjust the horizontal center of the image.
6. Adjust the V CENTER data and adjust the vertical center of the image.
7. Input the MODE1 1080/60i (1125) cross-hatch signal.

8. Adjust the H SIZE, H LIN BAL, H LIN TOP, and H LIN BOTTOM data as shown in Fig. 1-9. (Set the same value for H LIN TOP and H LIN BOTTOM.)

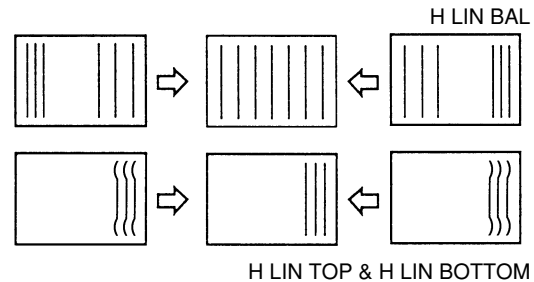

Fig. 1-9

9. Adjust the V SIZE, V LIN AMP, and V LIN BAL data as shown in Fig. 1-8.

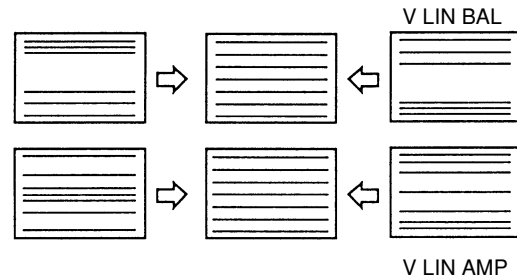

Fig. 1-8

10. Adjust the H PIN and H PIN BAL data so that the trapezoid distortion and PIN distortion at the side disappear as shown in Fig. 1-10.
11. Adjust the H KEY and H KEY BAL data as shown in Fig. 1-11.
12. Repeat the above adjustments and optimize the horizontal and vertical linearity.

13. Change the SCREEN MODE for the following modes as well, and perform adjustments in the same way.

MODE 2	1080/60i(33kHz)	16:9	UNDER SCAN
MODE 3	1035/60i(33kHz)	16:9	NORMAL SCAN
MODE 4		16:9	UNDER SCAN
MODE 5	720/60P(45kHz)	16:9	NORMAL SCAN
MODE 6		16:9	UNDER SCAN
MODE 7		16:9	NORMAL SCAN
MODE 8	480/60P(31kHz)	16:9	UNDER SCAN
MODE 9		4:3	NORMAL SCAN
MODE 10		4:3	UNDER SCAN
MODE 11		16:9	NORMAL SCAN
MODE 12	480/60i(15kHz)	16:9	UNDER SCAN
MODE 13		4:3	NORMAL SCAN
MODE 14		4:3	UNDER SCAN
MODE 15	1080/48i(27kHz)	16:9	NORMAL SCAN
MODE 16		16:9	UNDER SCAN
MODE 17	1080/50i(28kHz)	16:9	NORMAL SCAN
MODE 18		16:9	UNDER SCAN
MODE 19	720/50P(37kHz)	16:9	NORMAL SCAN
MODE 20		16:9	UNDER SCAN
MODE 21	575/50P(31kHz)	16:9	NORMAL SCAN
MODE 22		16:9	UNDER SCAN
MODE 23		4:3	NORMAL SCAN
MODE 24		4:3	UNDER SCAN
MODE 25	575/50i(15kHz)	16:9	NORMAL SCAN
MODE 26		16:9	UNDER SCAN
MODE 27		4:3	NORMAL SCAN
MODE 28		4:3	UNDER SCAN

• Common items for modes

- DY inclination
- Up/down V PIN distortion
- Horizontal trapezoidal distortion

• Items differing between modes

- TLV
- H SIZE
- H CENTER
- H PHASE
- V SIZE
- V CENTER
- H LIN BAL
- H LIN TOP
- H LIN BOTTOM
- V LIN AMP
- V LIN BAL
- H PIN
- H PIN BAL
- H KEY
- H KEY BAL
- H CORNER S

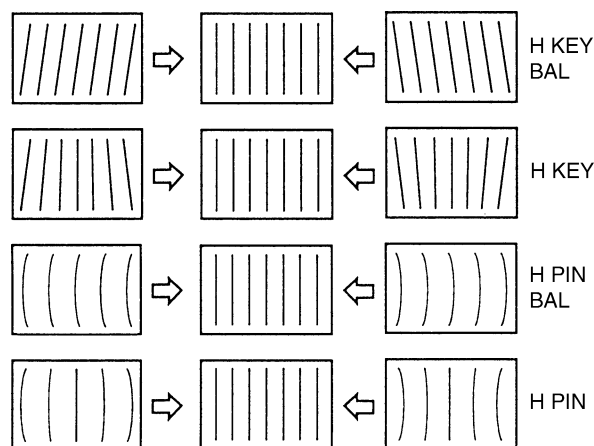

Fig. 1-10

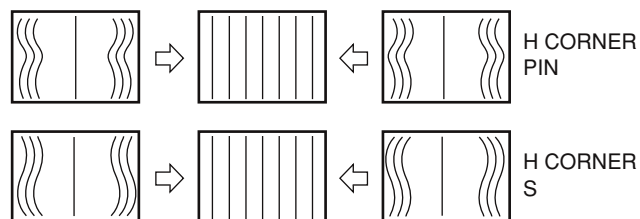

Fig. 1-11

[Convergence Adjustment]

• Preparation

1. Input the MODE9 480/60p (525p) cross-hatch signal to the BKM-68X (analog component input adaptor).
2. Press the 16 : 9 button to set 4 : 3 mode.
3. Set the 6-pole magnet of the DY to the OFFSET state.

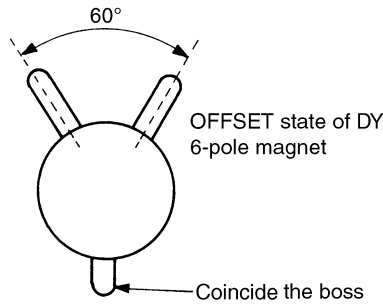

Fig. 1-12

4. Confirm that the following data is in the pre-set value (128).

V CONV TOP
 V STATIC CONV
 V CONV BOTTOM
 H STATIC CONV

Note

These adjustment menus are located in the SYSTEM CONFIGURATION menu → MAINTENANCE → DEFLECTION (4/5).

• HMC and VMC correction by the 6-pole magnet

1. HMC (horizontal mis-convergence) correction by the 6-pole magnet and movement electronic beam

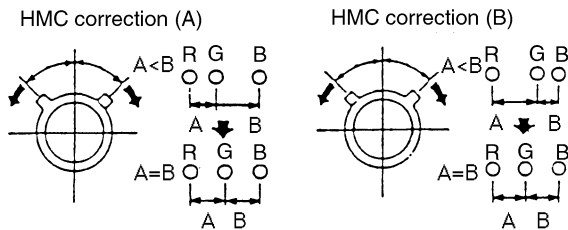

Fig. 1-13

2. Correction of 6-pole magnet VMC (vertical mis-convergence) and movement of electronic beam

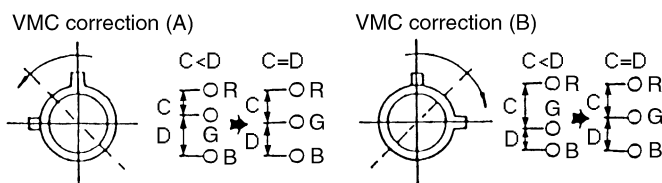

Fig. 1-14

[Static Convergence Adjustment]

• Horizontal static convergence

1. Adjust RV1 (H STAT) on the C board to align the red and green dots horizontally at the center of the screen to overlap.

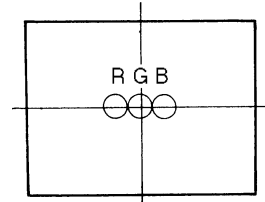

Fig. 1-15

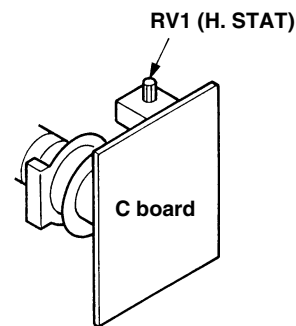

Fig. 1-16

[Convergence Adjustment]

• Preparation

1. Input the MODE9 480/60p (525p) cross-hatch signal to the BKM-68X (analog component input adaptor).
2. Press the 16 : 9 button to set 4 : 3 mode.

• Convergence adjustment

1. Minimize the vertical mis-convergence in the center at the left-most end and at the right-most end of screen using the DY correction reactors XBV and XCV.
 - * Because TLV is used for horizontal trapezoidal distortion adjustment, adjust the convergence while maintaining the correct adjustment of the horizontal trapezoidal distortion correction only when MSV is extremely poor.
2. Adjust the following data so that the mis-convergence becomes minimum at the top and bottom parts of the screen. (Keep the H STAT data to be 128, and do not change it to any data other than 128.)

V CONV TOP

V STATIC CONV

V CONV BOTTOM

Note

These adjustment menus are located in the SYSTEM CONFIGURATION menu → MAINTENANCE → DEFLECTION (4/5).

3. Copy the respective adjustment data into all modes. Then confirm the vertical and horizontal convergence again. If any mis-convergence is noticed, adjust the convergence again.

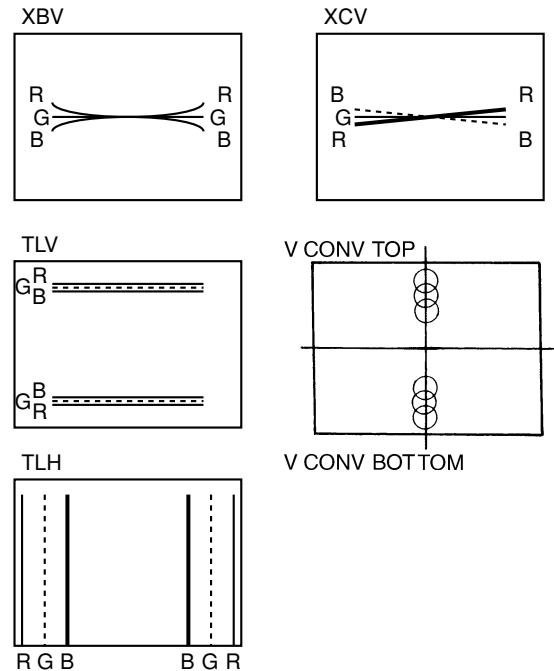

Fig. 1-17

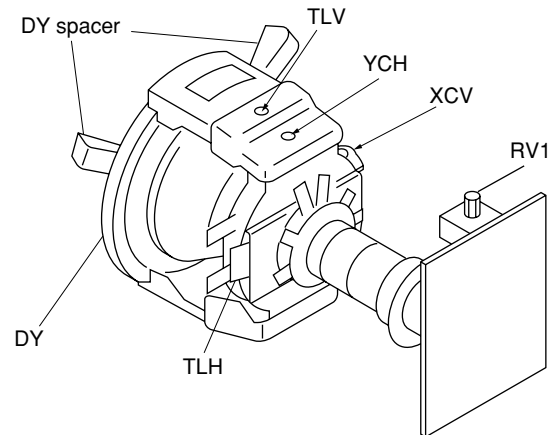

Fig. 1-18

[G2 Adjustment]

Note

These adjustment menus are located in the SYSTEM CONFIGURATION menu → MAINTENANCE → DEFLECTION (4/5).

1. Input the 1080/60i (1125) color bar signal to the BKM-68X (analog component input adaptor). (CHROMA: OFF state)
2. Connect the probe of the oscilloscope to each R, G, B cathode (TP2, 3, 4) of the C board, and check the DC voltages of the color bar signal pedestal portions. (20 V/Div)
3. Connect the probe of the oscilloscope to the cathode with the highest pedestal DC voltage.
4. Adjust the G2 REF data so that the DC voltage at the pedestal becomes the value as shown below.

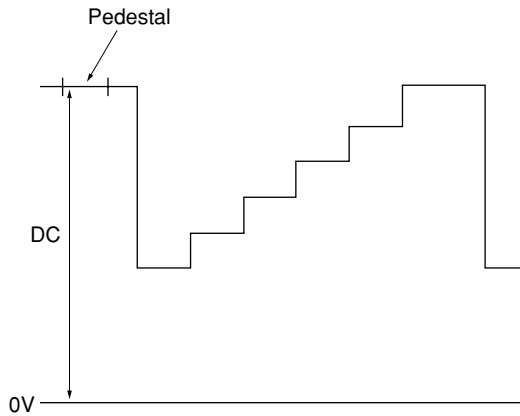

Specifications : 100 ± 2.5 Vdc

Fig. 1-21

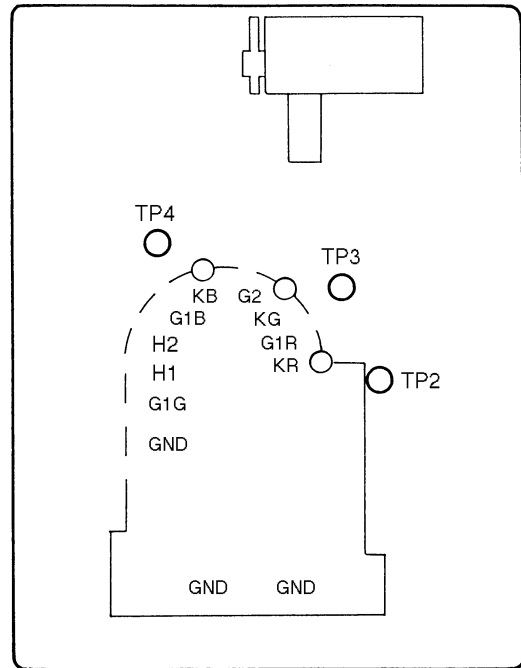

C board -B SIDE-

Fig. 1-22

[White Balance Adjustment]

Note

Perform the landing adjustment and the digital uniformity adjustment before the white balance adjustment as much as possible.

1. This section describes the overview of the adjustment and calibration of the color analyzer to be used for the adjustment.

1.1 Obtaining the Parameters for Converting the RGB Drive Voltage of the CRT to the Chromaticity Coordinate

This monitor comes equipped with a function to copy color temperature between several monitors. Since the CRT drive voltage depends on each individual CRT. The same color temperature cannot be obtained even if the same drive voltage is supplied to several monitors. Consequently, to copy a certain color temperature between several monitors, there is a need to transmit data which does not depend on the CRT using the xyY chromaticity coordinate.

When the SYSTEM/COLOR TEMP/FACTORY ADJ menu of the MAINTENANCE menu is selected and executed, the D93 color temperature will automatically be adjusted, and at the same time, the parameters for converting the drive voltage and chromaticity coordinate will be created. Use these parameters when copying color temperature to other monitors and copying color temperature to the memory card.

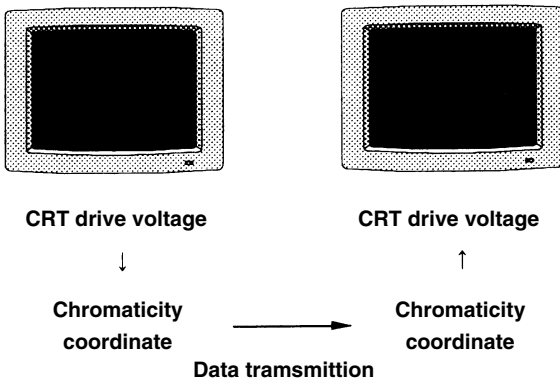

Fig. 1-23

2. Preparations for Adjustments

- 2.1 Input the HD signal (1125) into the Y/G input terminal of the BK board to display it on the screen.
- 2.2 Connect the RS-232C terminal of CA-100 and the OPTION terminal of the monitor using the cables indicated at Required Tools and Measuring Instruments (see page 3-1).
- 2.3 Set CA-100 as follows, and attach the measuring probe of CA-100 to the center of the CRT screen.

Display mode: xyY mode:
Baud Rate 9600

- 3. Receive the all white signal of MODE_1 1080/60i NORMAL SCAN.
- 4. Select SYSTEM CONFIGURATION → MAINTENANCE → SYSTEM → COLOR TEMP → FACTORY ADJ, and attach the sensor of the color analyzer to the center of the CRT screen.
- 5. Press the ENTER button to start the white balance auto adjustment.

Note

During adjustment, cover the CRT screen with a blackout cloth to shut out the external light.

W/B adjustment data

D65

	x	y	Y [cd/m ²]
C/O	0.313	0.329	2.7
H/L	0.313	0.329	100.0

D93

	x	y	Y [cd/m ²]
C/O	0.283	0.297	2.7
H/L	0.283	0.297	100.0

D61

	x	y	Y [cd/m ²]
C/O	0.320	0.336	2.7
H/L	0.320	0.336	100.0

Section 3

Safety-Related Adjustments

High Voltage Regulator Check/Adjustment

(RV501)

Perform the following checks/adjustments when the following parts (on the schematic diagram) have been replaced.

PA board R505, R506, R508, R509, R510, R511, R512, R514, R515, R517, IC501, IC502, RV501

PC board T701

1. Turn OFF the power.
2. Connect the static voltmeter to the anode cap of the CRT.
Static voltmeter : Calibrated to an input impedance of above $2 \times 10^9 \Omega$.
(For example, Singer ESH-27X or ESH-23X)
3. Turn ON the power.
(Input voltage value : 264 VAC)
4. Input the 1080/60i (1125) monoscope signal (fh=33.75 kHz) to the BKM-68X (analog component input adaptor).
5. Press the BRIGHT and CONTRAST buttons to set the PRESET state. <The LED (green) on the button goes off.>
6. Check that the high voltage value is within the following range.
 $25.00 \pm 0.15 \text{ kV}$
7. If 6 is not satisfied, replace RV501 of the PA board to satisfy the specifications.
8. Remove the static voltmeter.
9. If RV501 has been replaced at step 7, fix it with epoxy resin (DP-190 made by 3M) after adjusting the RV.

+B check

Perform the following checks and adjustments when the following parts (on the schematic diagram) have been replaced.

G board IC604

1. Connect a digital voltmeter to TP1 of the G board.
(GND is TP6 of the G board)
 - Use a digital voltmeter with more than 4 digits.
2. Turn on the power.
(Input voltage value : 264 VAC)
3. Confirm that the TP1 voltage value is as shown below.
 $135.2 \pm 0.8 \text{ VDC}$.

High Voltage Hold-Down Check/Adjustment

(RV601)

Perform the following checks/adjustments when the following parts (on the schematic diagram) have been replaced.

PA board R652, R653, R654, R655, R656, D651, D652, D659, D660, Q651, Q652, RV601

PC board R707, D702

1. Turn OFF the power.
2. Connect the static voltmeter to the anode cap of the CRT.
Static voltmeter : Calibrated to an input impedance of above $2 \times 10^9 \Omega$.
(For example, Singer ESH-27X or ESH-23X)
3. Connect a 200 k Ω variable resistor between TP501 and TP502 (GND) of the PA board.
(Set the resistance of the 200 k Ω resistor to the maximum value.)
4. Turn ON the power.
(Input voltage value : 264 VAC)
5. Input the 1080/60i (1125) crosshatch signal (fh=33.75 kHz) to the BKM-68X (analog component input adaptor)
6. Press the BRIGHT and CONTRAST buttons to set the MANUAL state. <The LED (green) on the button goes ON.>
7. Use BRIGHT/CONTRAST to set each of them to the minimum value.
8. Decrease the resistance of the 200 k Ω variable resistor connected to TP501, and check that the high voltage value drops suddenly at the following values.
 $27.50 \pm 0.50 \text{ kV}$
9. If 8 is not satisfied, replace RV601 of the PA board to satisfy the specifications.
10. Remove the 200 k Ω variable resistor.
11. Check that the high voltage values satisfy the following values.
 $25.00 \pm 0.15 \text{ kV}$
12. Remove the static voltmeter.
13. If RV601 has been replaced at step 9, fix it with epoxy resin (DP-190 made by 3M) after adjusting the RV.

Beam Current Protector Check

Perform the following checks when the following parts (☑ on the schematic diagram) have been replaced.

- ☑ PA board R602, R603, R604, R605, R606, R607, IC601, Q601, Q602, D601, D608, D609
- ☑ PC board R701, R702, R703, R704, R705, R706
- ☑ BK board ... R604, R605, IC009

1. Turn OFF the power.
2. Disconnect the CN703 connector of the PC board.
3. Connect a DC ammeter between pins 1 and 2 of CN703 of the PC board.
4. Short-circuit between pins 3 and 4 of CN703 of the PC board using a jumper.
5. Short-circuit between TP503 and TP502 (GND) of the PA board using a jumper.
(Disable ABL.)
6. Turn ON the power.
7. Input the 1080/60i (1125) 100% all white signal.
8. Press the BRIGHT and CONTRAST buttons to set the MANUAL state. <The LED (green) on the button goes ON.>
9. Turn the BRIGHT and the CONTRAST starting from the MIN end toward the MAX end gently. When the ammeter reading reaches the following value, confirm that the protectors do not operate.
1.25 mA
10. Turn the BRIGHT and the CONTRAST starting from the MIN end toward the MAX end gently. When the ammeter reading reaches the following value, confirm that the protectors operate [OVER LOAD LED on the front of monitor is gently flashed].
 1.50 ± 0.25 mA
11. Turn OFF the power.
12. Remove the jumper from between TP503 and TP502 (GND) of the PA board.
13. Turn ON the power again.
14. Input the 1080/60i (1125) monoscope signal (fh=15.73 kHz) to the BKM-68X (analog component input adaptor).
15. Check that when the BRIGHT and CONTRAST buttons are rotated from MIN to MAX, the ABL operates. (The OVER LOAD LED should light in orange, and the maximum reading of the current meter should be the value below.)
1.10 \pm 0.20 mA (4:3)
0.90 $^{+0.20}_{-0.15}$ mA (16:9)
16. Remove the DC ammeter.
17. Remove the jumper between pins 3 and 4 of the CN703 of the PC board.
18. Connect the CN703 connector of the PC board.

**PA BOARD
-B SIDE-**

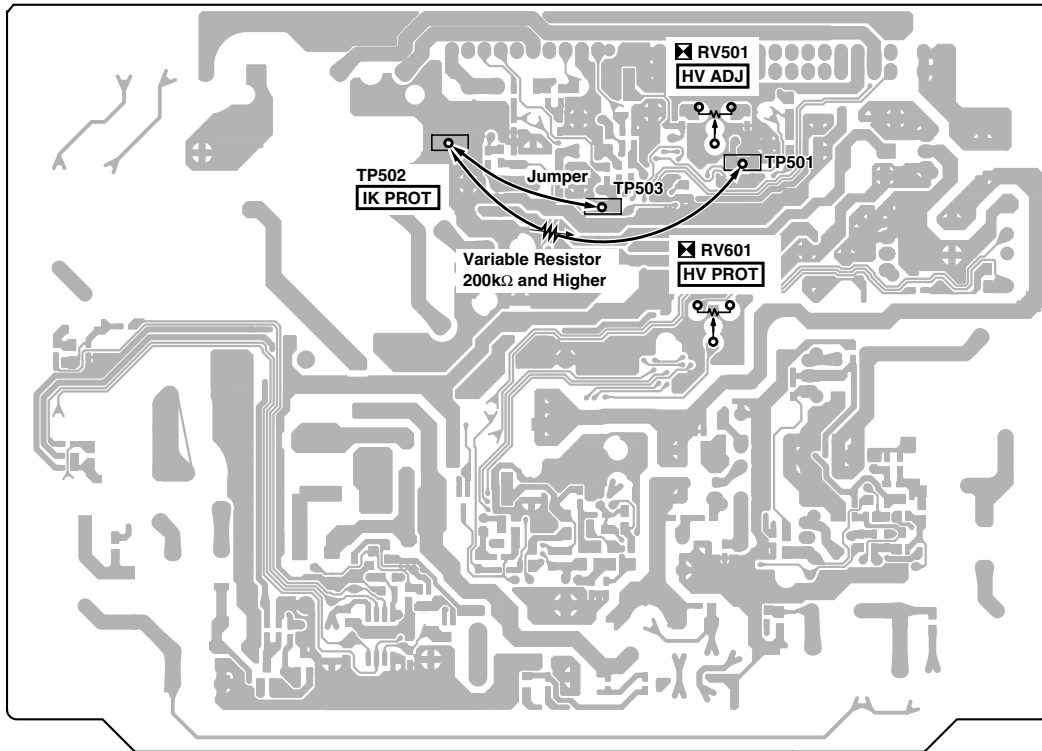

**PC BOARD
-B SIDE-**

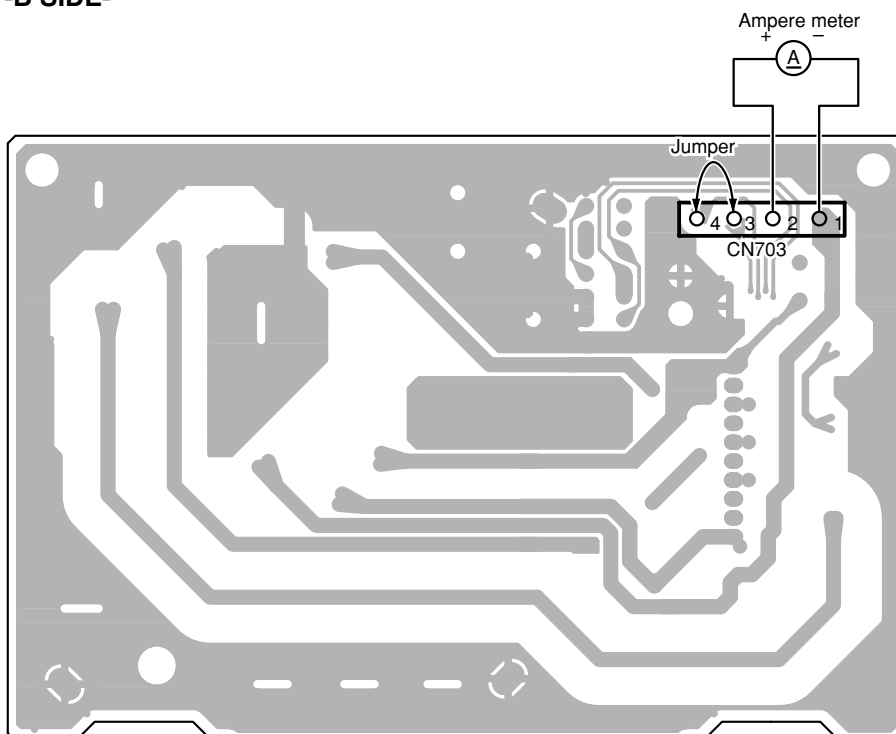

**G BOARD
-B SIDE-**

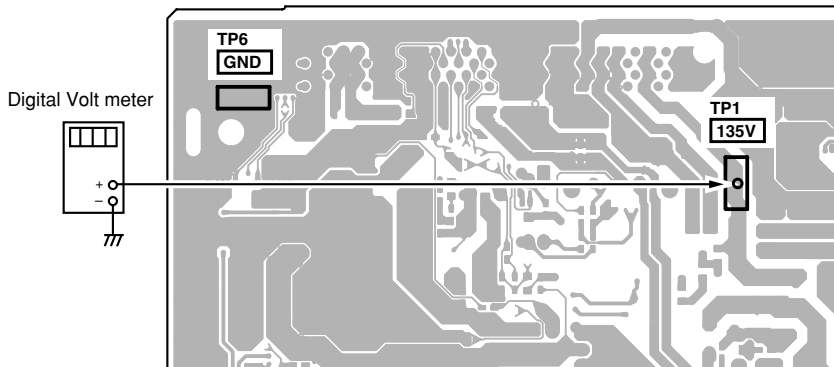

**PC BOARD
-B SIDE-**

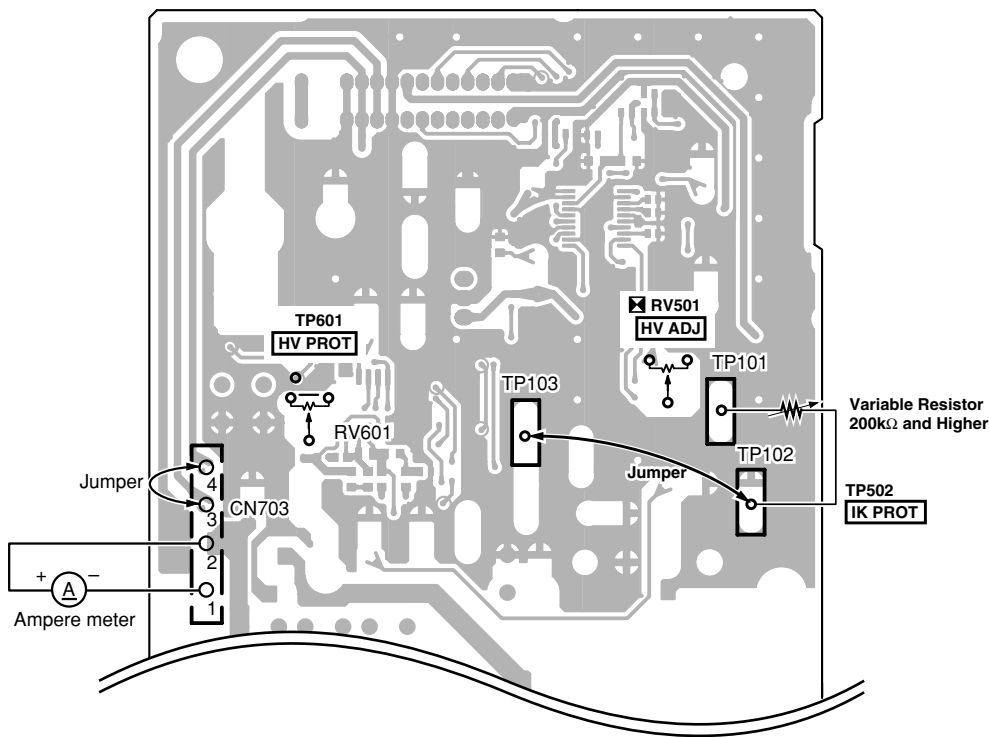

Section 4

Circuit Adjustments

4-1. BK Board Adjustments

This section describes the adjustments which are required when performing the maintenance and parts replacement of the BK board.

1. Bright center adjustment
2. 100 IRE adjustment
3. MATRIX adjustment (1)
4. MATRIX adjustment (2)
5. DRIVE Level adjustment
6. BIAS Level adjustment

Control settings

- Set as follows at the INPUT CONFIGURATION menu of the SETUP menu.

For the analog RGB signal:

FORMAT RGB

For the SDI signal:

FORMAT HD-SDI/D1 AUTO

- Select and execute SLOT 5 VIDEO in the FILE MANAGEMENT menu → DATA MAINTENANCE → RELOAD FACTORY DATA.

- Configure the following settings in the SYSTEM CONFIGURATION menu → MAINTENANCE → VIDEO (2/5).

CONTRAST 256

SUB CONTRAST 400

BRIGHT 256

CHROMA 256

Devices to be used

Name	Main Specifications	Equipment
Analog RGB generator	• 1080/60i (1125)	
SDI signal generator	• 1035/60i SMPTE 240M standard/1080/60i ITU-R BT.709/ 480/60i ITU-R BT601	
BKM-68X	Analog component input adaptor	
BKM-62HS	HD SDI/SDI input adaptor	
Oscilloscope	Frequency: DC to 150 MHz or more 2 phenomena or more (ADD mode)	Tektronix 2465 or equivalent

Tools

Name	Part No.	Remark
Extension board	A-1091-210-A	Z board
75 Ω terminator	—	× 4
Adjustment screwdriver	—	

Connection (1)

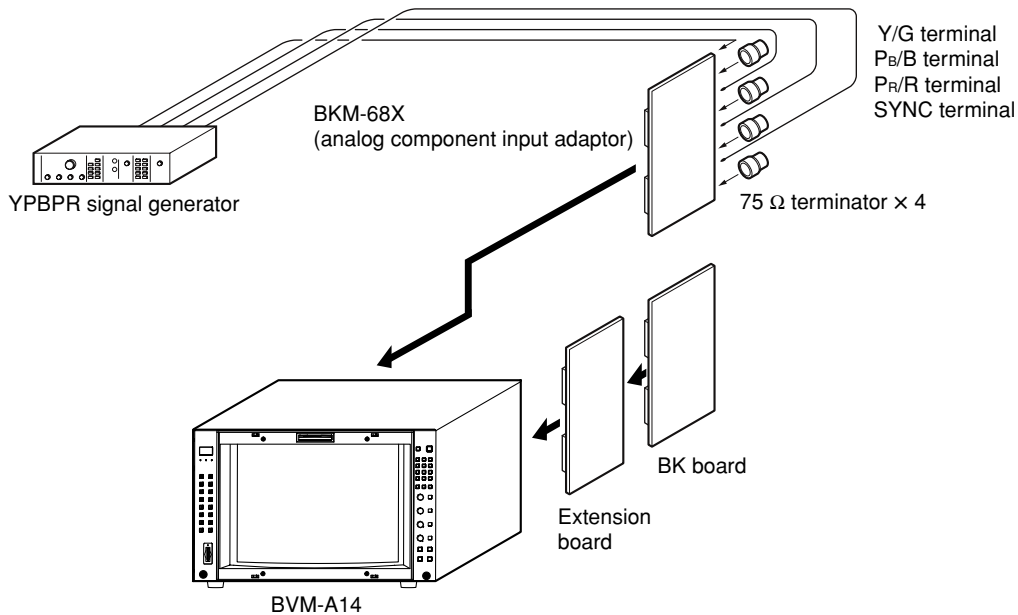

Connection (2)

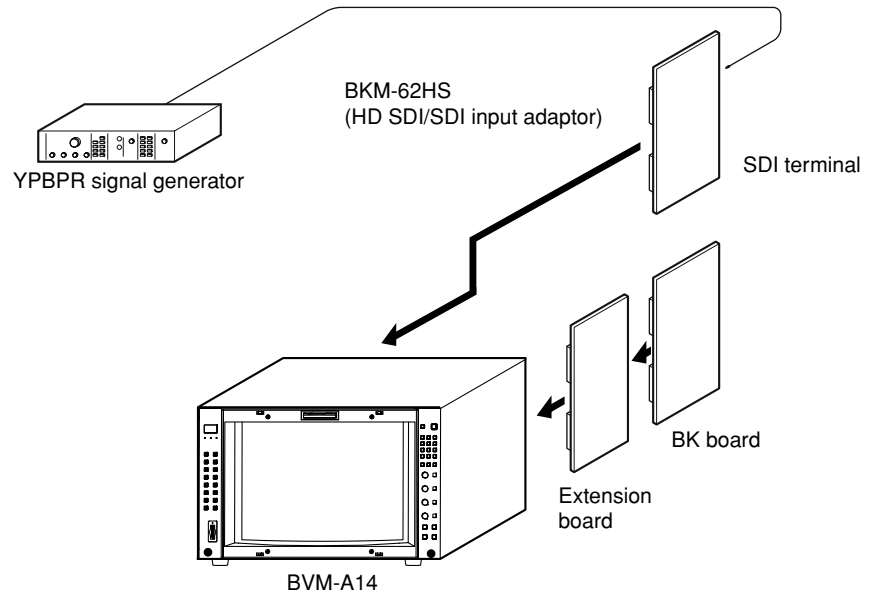

Connection (3)

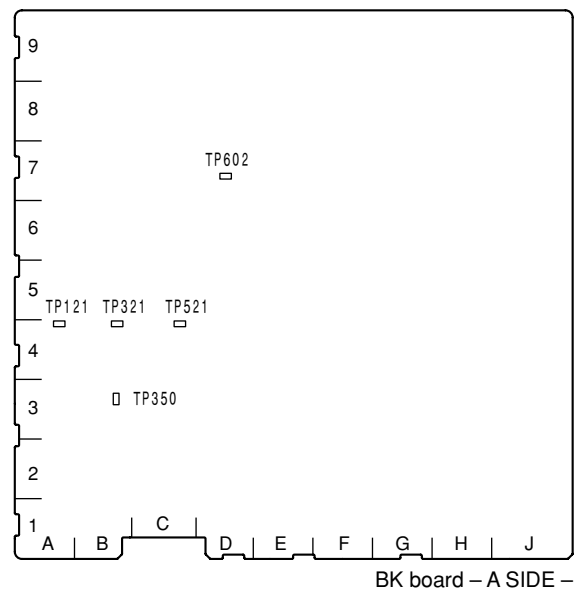

Procedure

1. Bright center adjustment

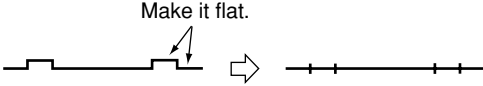
Adjustment Operation	Standard	Adjusting Point
<ul style="list-style-type: none"> Connect the oscilloscope to TP602. 	<p>The TP602 waveform is flat: Level difference: 0 ± 4 mV</p> <p>Make it flat.</p> 	<p>The adjustment menu is BRIGHT CENTER in SYSTEM CONFIGURATION → MAINTENANCE → VIDEO (2/5).</p>

2. 100 IRE adjustment

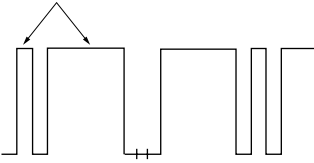
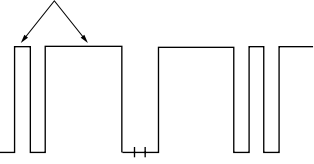
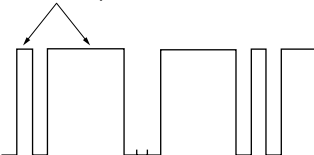
Adjustment Operation	Standard	Adjusting Point
<p>Step 1</p> <ul style="list-style-type: none"> Input "093" with the numeric keypad on the controller, and input the built-in 100% FLAT FIELD signal. Connect the oscilloscope to TP121. 	<p>100% WHITE level and the 100 IRE pulse level output from TP121 are equal: Level difference: 0 ± 4 mV</p> <p>Make them equal.</p> 	<p>The adjustment menu is R 100 IRE in SYSTEM CONFIGURATION → MAINTENANCE → VIDEO (3/5).</p>
<p>Step 2</p> <ul style="list-style-type: none"> Connect the oscilloscope to TP321. 	<p>100% WHITE level and the 100 IRE pulse level output from TP321 are equal: Level difference: 0 ± 4 mV</p> <p>Make them equal.</p> 	<p>The adjustment menu is G 100 IRE in SYSTEM CONFIGURATION → MAINTENANCE → VIDEO (3/5).</p>
<p>Step 3</p> <ul style="list-style-type: none"> Connect the oscilloscope to TP521. 	<p>100% WHITE level and the 100 IRE pulse level output from TP521 are equal: Level difference: 0 ± 4 mV</p> <p>Make them equal.</p> 	<p>The adjustment menu is B 100 IRE in SYSTEM CONFIGURATION → MAINTENANCE → VIDEO (3/5).</p>

3. MATRIX adjustment (1)

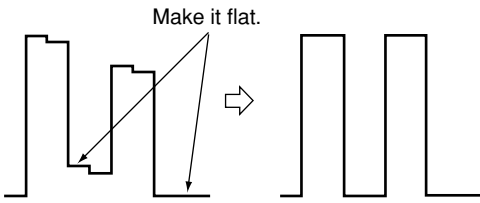
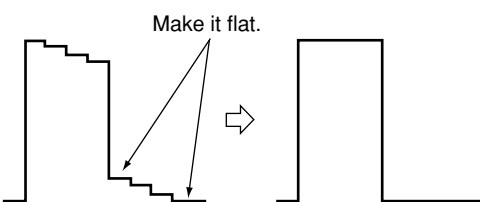
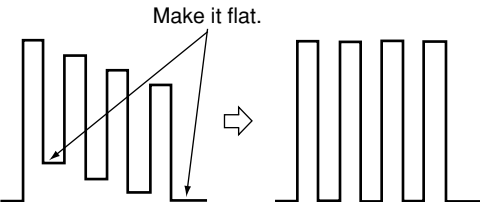
Adjustment Operation	Standard	Adjusting Point
<p>Step 1</p> <ul style="list-style-type: none"> Input the SMPTE 240M (1035/60i) 8-color bar signal (saturation: 100%) to BKM-62HS (HD SDI/SDI input adaptor). Set MATRIX in the INPUT CONFIGURATION menu to SMPTE240M. Set Y G GAIN to "853". Connect the oscilloscope to TP121 (RED). 	<p>The output waveform of TP121 (RED) is flat: Level difference: 0 ± 4 mV</p> 	<p>The adjustment menu is PR R GAIN in SYSTEM CONFIGURATION → MAINTENANCE → VIDEO (2/5).</p>
<p>Step 2</p> <ul style="list-style-type: none"> Connect the oscilloscope to TP321 (GREEN). 	<p>The output waveform of TP321 (GREEN) is flat: Level difference: 0 ± 10 mV</p> 	<p>The adjustment menu is G PR GAIN G PB GAIN in SYSTEM CONFIGURATION → MAINTENANCE → VIDEO (2/5).</p>
<p>Step 3</p> <ul style="list-style-type: none"> Connect the oscilloscope to TP521 (BLUE). 	<p>The output waveform of TP521 (BLUE) is flat: Level difference: 0 ± 10 mV</p> 	<p>The adjustment menu is PB B GAIN in SYSTEM CONFIGURATION → MAINTENANCE → VIDEO (2/5).</p>

- Set MATRIX in the INPUT CONFIGURATION menu to ITU709. Change the input signal to ITU-R BT.709 (1080/60i), and adjust steps 1 to 3.
- Set MATRIX in the INPUT CONFIGURATION menu to ITU601. Change the input signal to ITU-R BT601 (480/60i), and adjust steps 1 to 3.

4. MATRIX adjustment (2)

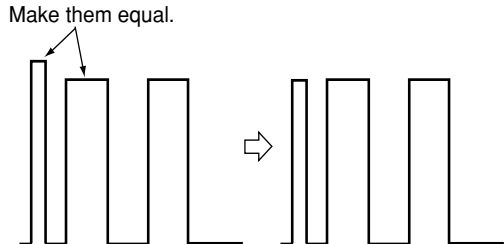
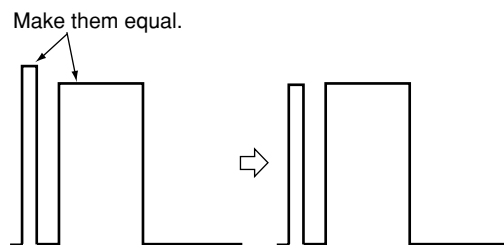
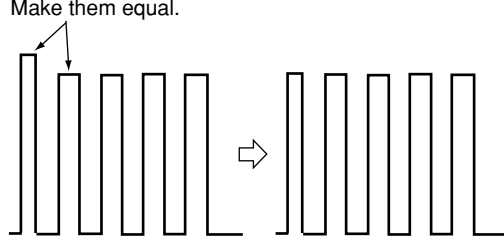
Adjustment Operation	Standard	Adjusting Point
<p>Step 1</p> <ul style="list-style-type: none"> Input the 1080/60i 8-color bar signal (saturation: 100%) to the BKM-68X (analog component input adaptor). Set FORMAT in the INPUT CONFIGURATION menu to RGB. Connect the oscilloscope to TP121 (RED). 	<p>100% WHITE level and the 100 IRE pulse level output from TP121 (RED) are equal: Level difference: 0 ± 4 mV</p> <p>Make them equal.</p> 	<p>The adjustment menu is PR R GAIN in SYSTEM CONFIGURATION → MAINTENANCE → VIDEO (2/5).</p>
<p>Step 2</p> <ul style="list-style-type: none"> Connect the oscilloscope to TP321 (GREEN). 	<p>100% WHITE level and the 100 IRE pulse level output from TP321 (GREEN) are equal: Level difference: 0 ± 4 mV</p> <p>Make them equal.</p> 	<p>The adjustment menu is Y G GAIN in SYSTEM CONFIGURATION → MAINTENANCE → VIDEO (2/5).</p>
<p>Step 3</p> <ul style="list-style-type: none"> Connect the oscilloscope to TP521 (BLUE). 	<p>100% WHITE level and the 100 IRE pulse level output from TP521 (BLUE) are equal: Level difference: 0 ± 4 mV</p> <p>Make them equal.</p> 	<p>The adjustment menu is PB B GAIN in SYSTEM CONFIGURATION → MAINTENANCE → VIDEO (2/5).</p>

5. DRIVE Level adjustment

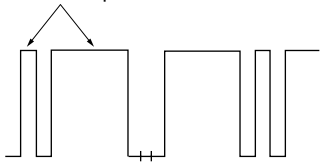
Adjustment Operation	Standard	Adjusting Point
<p>Step 1</p> <ul style="list-style-type: none"> Input "093" with the numeric keypad on the controller, and input the built-in 100% FLAT FIELD signal. Connect the oscilloscope to TP350. 	<p>100% WHITE level and the 100 IRE pulse level output from TP350 are equal: Level difference: 0 ± 4 mV</p> <p>Make them equal.</p> 	<p>The adjustment menu is DRIVE LEVEL in SYSTEM CONFIGURATION → MAINTENANCE → VIDEO (3/5).</p>

6. BIAS Level adjustment

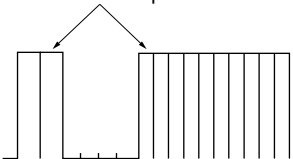
Adjustment Operation	Standard	Adjusting Point
<ul style="list-style-type: none"> Input "092" with the numeric keypad on the controller, and input the built-in 20% FLAT FIELD signal. Connect the oscilloscope to TP350. 	<p>100% WHITE level and the BIAS REF pulse output from TP350 are equal: Level difference: 0 ± 4 mV</p> <p>Make them equal.</p>  <p>Note: Check the waveform by its V cycle.</p>	<p>The adjustment menu is BIAS LEVEL in SYSTEM CONFIGURATION → MAINTENANCE → VIDEO (3/5).</p>

7. Reference

For the following adjustments, refer to Section 3-1. "Setup Adjustment When CRT is Replaced".

G2 adjustment

White balance adjustment

Section 5

Semiconductor Pin Assignments

The following describes the semiconductor types used in this unit.

For semiconductors marked with page numbers in the index, refer to the corresponding pages in this section.

However, in some cases incompatible types are also listed, therefore, when a part is to be replaced, also refer to the Spare Parts section.

In addition, for semiconductors with ID Nos., refer to the separate CD-ROM titled “Semiconductor Pin Assignments” (Sony Part No. 9-968-546-xx) that allows searching for parts by semiconductor type or ID No.

The semiconductors in the manual or on the CD-ROM are listed by equivalent types. Thus the external view or the index mark indication may differ from the actual type.

Pin assignments and block diagrams are based on the IC manufacturer’s data book.

本機に使用されている半導体型名の一覧を下記に示します。索引中、ページが記載されている半導体は、本章の該当ページを参照してください。ただし、互換性のない型名を併記している場合がありますので、部品を交換するときは、Spare Partsの章を参照してください。

また、ID番号が記載されている半導体は、別途発行の“Semiconductor Pin Assignments” CD-ROM版 (ソニー部品番号：9-968-546-xx)を参照してください。半導体型名またはID番号から検索ができます。

マニュアルまたはCD-ROMに掲載されている半導体は、それぞれの機能を等価的に表わしたものです。

外観やインデックスマークの表示方法が実物と異なる場合があります。

ピン配置およびブロック図はICメーカーのデータブックに従いました。

DIODE	Page or ID No.	TRANSISTOR	Page or ID No.
1SS119-25	DA001-01	2SA1037AK-T146-R	TC001-01
1SS119-25TD	DA001-01	2SA1162-G	TC001-01
1SS133T-77	DA001-01	2SA1330-06	TC001-01
1SS357-TPH3	DC008-02	2SA1576A-T106-QR	TC001-01
1SS376TE-17	DC008-02	2SA1610-T1Y34	TC001-01
		2SA1610-Y33	TC001-01
HN1D03FU-TE85L	DC005-05	2SB1121-ST	TC002-01
HN1D03FU-TE85R	DC005-05	2SB1151	TM006-01
		2SB734-34	TR009-01
MA111-(K8).S0	DC008-01	2SC1623-L5L6	TC001-02
		2SC3950-D	TM007-01
RB060L-40TE25	DC007-01	2SC3955-DE	TM007-01
RD12SB-T1	DC008-04	2SC4081-R	TC001-02
RD2.0SB-T1	DC008-04	2SC4081T106R	TC001-02
RD24SB-T1	DA001-02	2SC4176-B34	TC001-02
RD27ES-B2	DA001-02	2SC4176T1B33B34B35	TC001-02
RD27SB-T1	DC008-04	2SC4686A(LBSONY)	TM001-07
RD3.3SB	DC008-04	2SD1621-ST	TC002-02
RD3.3SB-T1	DC008-04	2SD1623-S	TC002-02
RD3.9SB	DC008-04	2SD1683-T	TM007-01
RD30SB-T1	DC008-04		
RD4.7SB-T2	DC008-04	DTA114EUA-T106	TC001-04
RD5.6SB-T1	DC008-04	DTA123JUA-T106	TC001-04
RD6.2SB	DC008-04	DTA144EKA-T146	TC001-04
RD8.2SB-T1	DC008-04	DTA144EUA-T106	TC001-04
		DTC114GKAT146	TC001-03
		DTC114YUA-T106	TC001-03
		DTC123JUA-T106	TC001-03
		DTC144EUA-T106	TC001-03
		SI4431DY-T1	TC012-04
		SI4559EY-T1	TC012-03
		SPA20N60C3	TM001-09
LED	Page or ID No.		
CL-190D-CD	LC004-01		
CL-191YG-CD-T	LC004-01		
CL-270D-C-TS	LC004-01		

IC	Page or ID No.	
93LC46BT-I/SN	BR93LC46F	TL431CPK-E2
		NJM431U
BA25BC0FP-E2	BA18BC0FP-E2	TL5001CD
		TL5001
BA25BC0FP-TE2	BA18BC0FP-E2	TL5001CDR
		TL5001
		TLC2932IPWR
		TLC2932IPWR
CDCVF2505PWR	CDCVF2505PWR	TLC2933IPWR
		TLC2933IPWR
CXD1171M	CXD1171M	TPS5120DBTR
		TPS5120DBTR
CXD2309AQ-T6	CXD2309Q-T6	
EPC2LC20-TP	EPC2LC20	UPC1093J
		TL431CLP
EPC2LC20N-TP	EPC2LC20	UPC574J
		DR001-05
HD6417709SF133BV	HD6417709SF133BV	
LM2990SX-5.0	UA7905UC	
LM339NS	LM339	
LM393PS	UA393DC	
LM75CIMX-3	LM75	
LM7815CT	NJM78M05FA	
LM7912CT	NJM79M05FA	
LMH6502MAX	CLC520AJP	
LT1252CS8	LT1252CS8	
LT1252CS8-E2	LT1252CS8	
MAX3243CDBR	MAX3243CDBR	
MB86189PFV-G-BND-ER	MB86189PFV-G-BND-ER	
NJM082M	RC4558	
NJM2904M	RC4558	
NJM7812FA	NJM78M05FA	
NJM78M09DL1A(TE1)	NJM78M12DLA_TE1	
NJM78M12DL1A-TE1	NJM78M12DLA_TE1	
NJM79L05A	NJM79L03A	
NJM79M12DL1A-TE1	NJM79M12DLA_TE1	
SN74AHCT04PWR	TC74HC04P	
SN74LVC14APWR	TC74HC14P	
SN74LVC541APWR	SN74LS541N	
TC74HC4053AFT(EL)	MC74HC4053F	
TC74HC4538AFT(EL)	MC74HC4538N	
TC74HC4538AFT	MC74HC4538N	
TC74VHC04FT(EL)	TC74HC04P	
TC74VHC05FT(EL)	SN74HC05N	
TC74VHC123AFT(EL)	TC74HC123P	
TC74VHC14FT(EL)	TC74HC14P	
TC74VHCT04AFT(EL)	TC74HC04P	
TC74VHCT125AFT(EL)	MC74HC125N	
TC74VHCT32AFT	TC74HC32P	
TC74VHCT541AFT(EL)	MC74HC541N	
TC7SZ05FU(TE85R)	TC7SZ05FU_TE85R	
TC7SZ125FU(TE85R)	NC7SZ125P5	
TC7W53FU(TE12R)	TC4W53FU	
TC7W53FU-TE12R	TC4W53FU	
TD62381F	TD62381P	
TD62783AF(S)	TD62783AP	
TL082CPWR	RC4558	
TL1451ACPWR-12	TL1451CNS	
TL16C550CPT	TL16C550CPT	

Section 6

Spare Parts

6-1. Notes on Repair Parts

1. Safety Related Components Warning

WARNING

Components marked \triangle are critical to safe operation. Therefore, specified parts should be used in the case of replacement.

WARNHINWEIS

Les composants identifiés par la marque \triangle sont critiques pour la sécurité. Ne les remplacer que par une pièce portant le numéro spécifié.

2. Standardization of Parts

Some repair parts supplied by Sony differ from those used for the unit. These are because of parts commonality and improvement. Parts List has the present standardized repair parts.

3. Stock of Parts

Parts marked with “o” at SP (Supply Code) column of the Spare Parts list may not be stocked. Therefore, the delivery date will be delayed. Items with no part number and no description are not stocked because they are seldom required for routine service.

4. Units for Capacitors, Inductors and Resistors

The following units are assumed in Schematic Diagrams, Electrical Parts List and Exploded Views unless otherwise specified.

Capacitors	: μF
Inductors	: μH
Resistors	: Ω

5. X-ray Radiation Safety Related Parts

The components marked \boxtimes in this Spare Parts List have been carefully factory-selected for each set in order to satisfy regulations regarding X-ray radiation.

6-2. Exploded Views

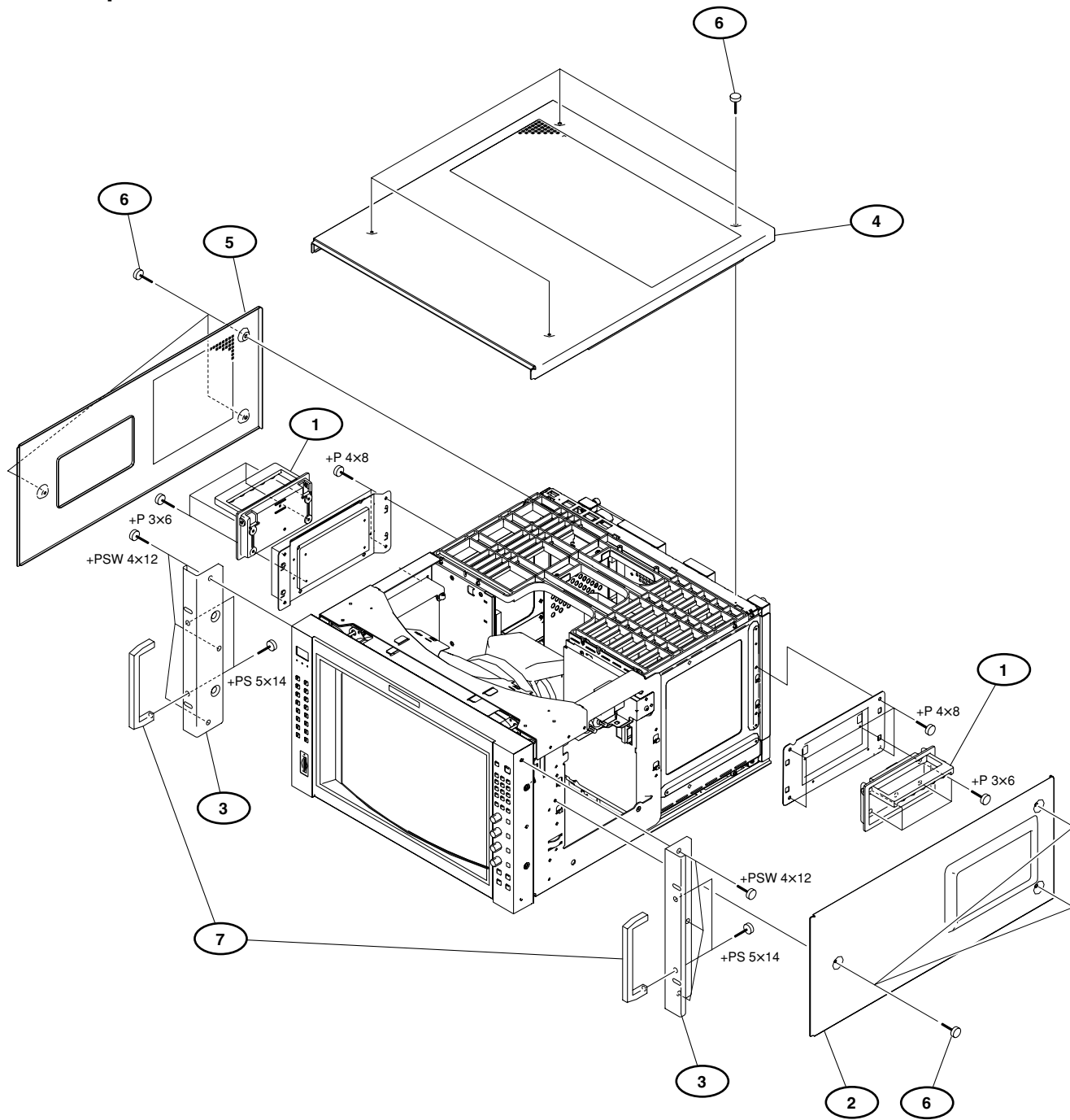

No.	Part No.	SP Description
1	△ X-3608-706-1	s HANDLE ASSY
2	△ 2-664-766-01	s CABINET (RIGHT)
3	4-050-922-01	s BASE, HANDLE
4	△ 4-050-931-13	o CABINET (UPPER)
5	△ 4-050-933-11	s CABINET (LEFT)
6	4-063-969-21	s SCREW (OS), CASE, CLAW
7	△ 4-337-212-12	o HANDLE

- 7-628-000-04 s SCREW +PS 5X14
- 7-682-147-09 s SCREW +P 3X6
- 7-682-161-09 s SCREW +P 4X8
- 7-682-963-09 s SCREW +PSW 4X12

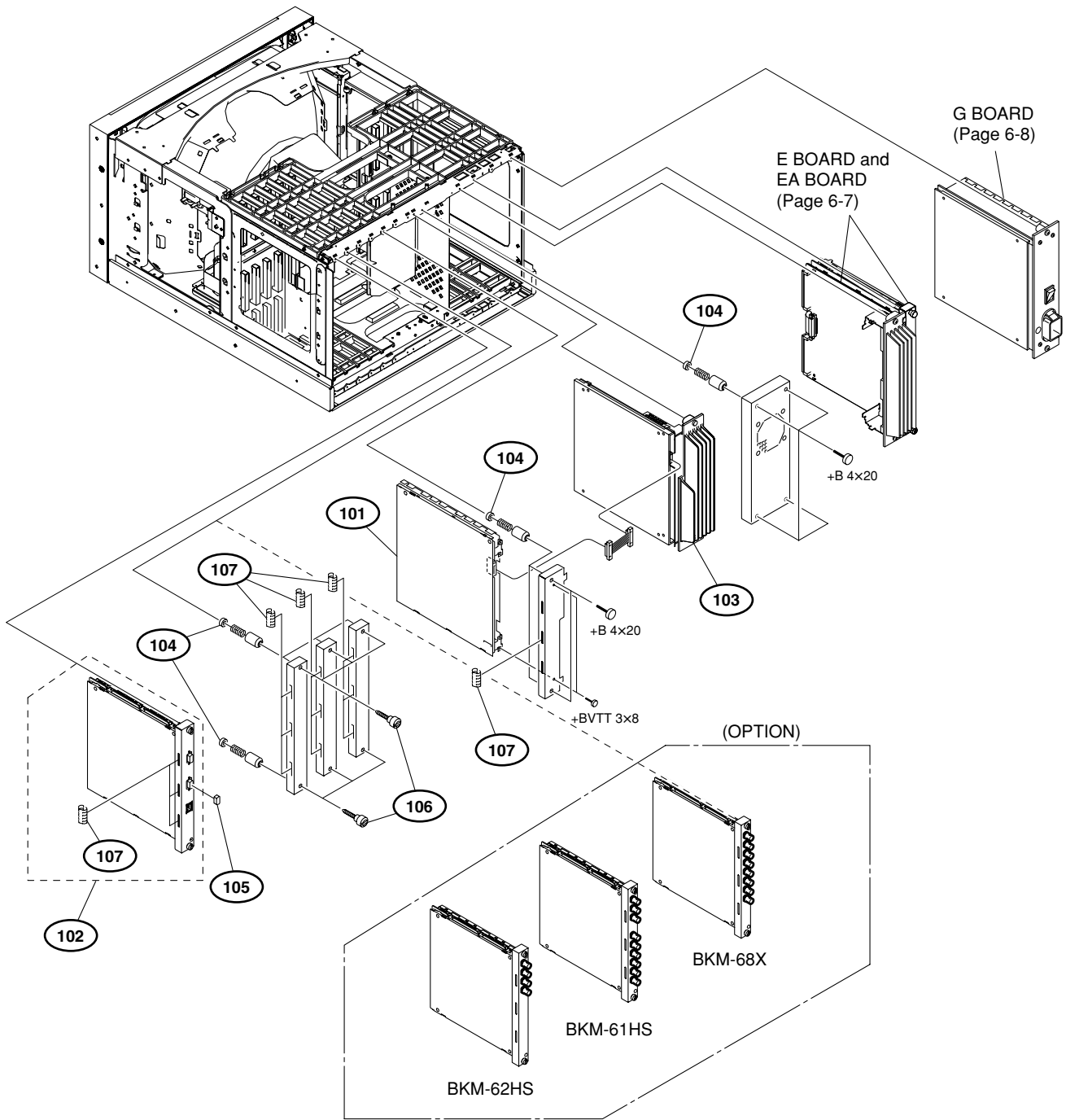

No.	Part No.	SP	Description
101	A-1091-090-A	s	MOUNTED CIRCUIT BOARD, BK
102	A-1171-143-A	s	MOUNTED CIRCUIT BOARD, BC
103	A-1166-053-A	s	MOUNTED CIRCUIT BOARD, CA
104	3-648-057-02	s	NUT (ISO-4), U
105	3-673-948-21	s	CAP, DUST
106	4-050-804-01	o	SCREW, PANEL STOPPER
107	4-076-108-01	o	FINGER, SHIELD
	7-682-566-04	s	SCREW +B 4X20
	7-685-872-09	s	SCREW +BVTT 3X8 (S)

Chassis

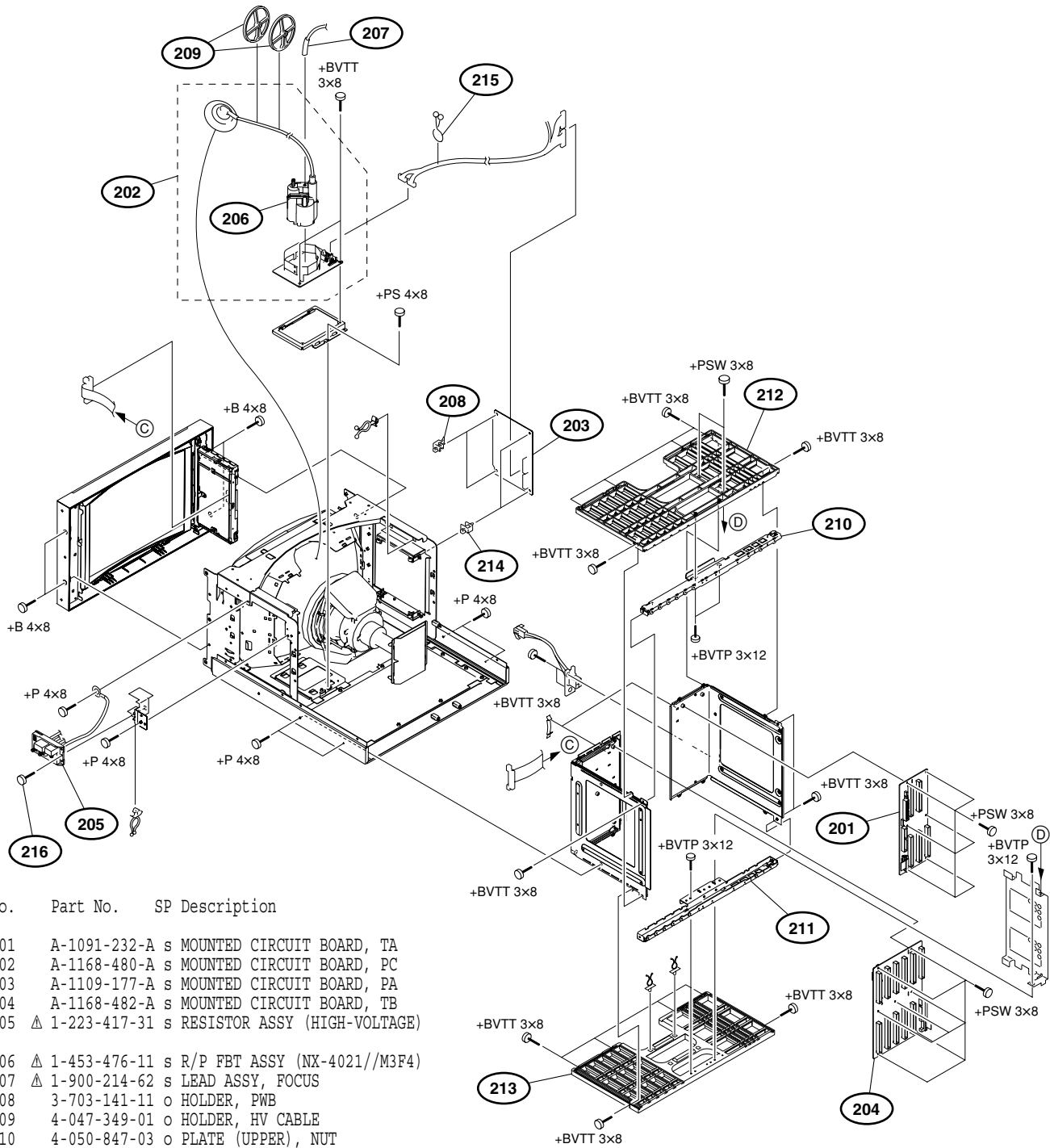

No.	Part No.	SP	Description
201	A-1091-232-A	s	MOUNTED CIRCUIT BOARD, TA
202	A-1168-480-A	s	MOUNTED CIRCUIT BOARD, PC
203	A-1109-177-A	s	MOUNTED CIRCUIT BOARD, PA
204	A-1168-482-A	s	MOUNTED CIRCUIT BOARD, TB
205	△ 1-223-417-31	s	RESISTOR ASSY (HIGH-VOLTAGE)
206	△ 1-453-476-11	s	R/P FBT ASSY (NX-4021//M3F4)
207	△ 1-900-214-62	s	LEAD ASSY, FOCUS
208	3-703-141-11	o	HOLDER, PWB
209	4-047-349-01	o	HOLDER, HV CABLE
210	4-050-847-03	o	PLATE (UPPER), NUT
211	4-050-848-03	o	PLATE (LOWER), NUT
212	4-072-207-03	o	BOARD (UPPER), CARD SLOT
213	4-072-208-03	o	BOARD (LOWER), CARD SLOT
214	4-353-620-11	o	HINGE, PC BOARD
215	4-847-334-02	o	PURSE LOCK (DIA.15)
216	4-382-854-11	s	SCREW (M3X10), P, SW (+)

7-682-161-09	s	SCREW +P 4X8
7-682-561-09	s	SCREW +B 4X8
7-682-661-01	s	SCREW +PS 4X8
7-682-948-01	s	SCREW +PSW 3X8
7-685-872-01	s	SCREW +BVTT 3X8 (S)
7-685-648-79	s	SCREW +BVTP 3X12 TYPE2 IT-3

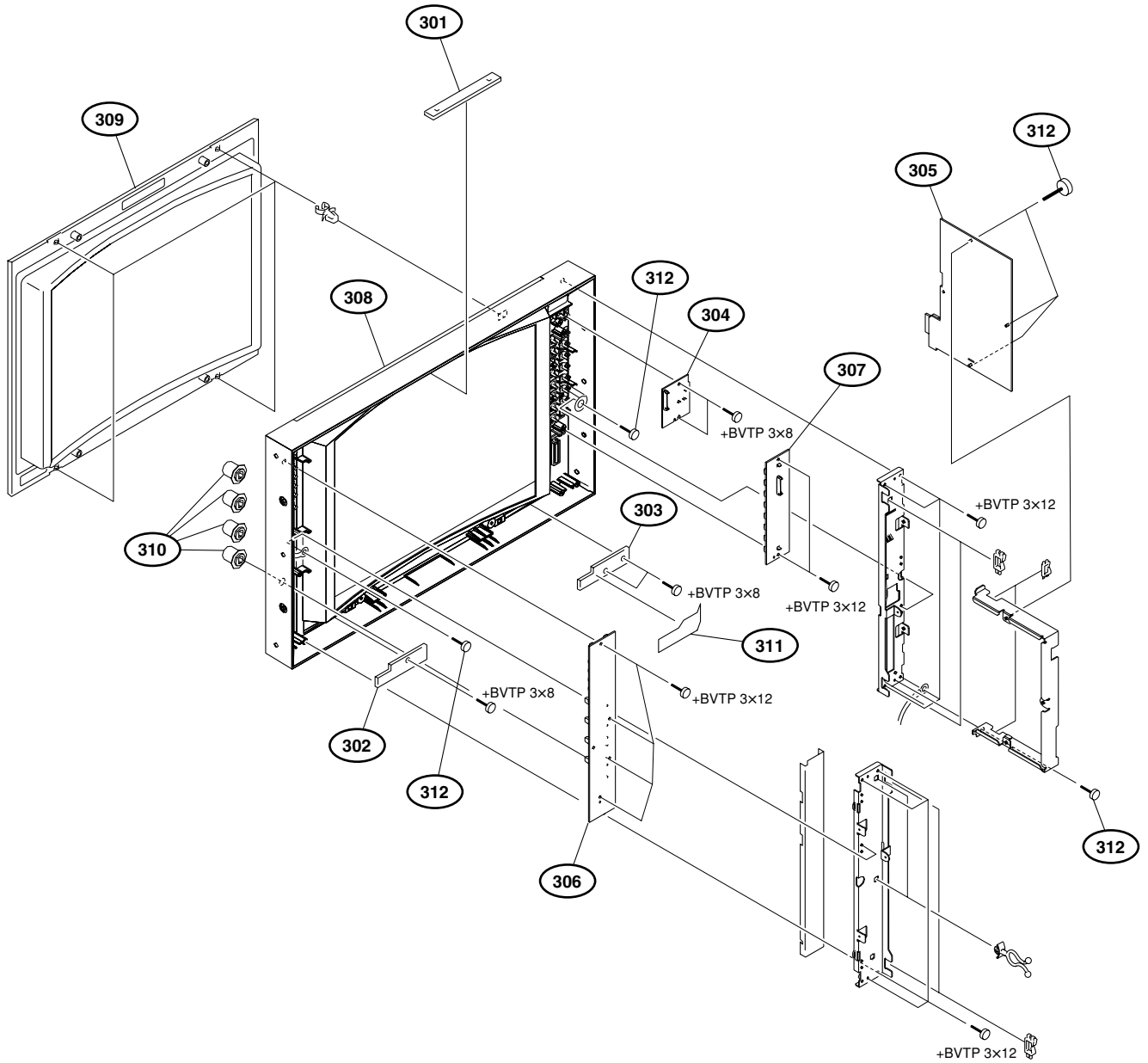

No.	Part No.	SP Description
301	A-1091-224-A	s MOUNTED CIRCUIT BOARD, YA
302	A-1091-225-A	s MOUNTED CIRCUIT BOARD, YB
303	A-1091-226-A	s MOUNTED CIRCUIT BOARD, YC
304	A-1091-344-A	s MOUNTED CIRCUIT BOARD, HD
305	A-1091-403-A	s MOUNTED CIRCUIT BOARD, HC
306	A-1133-995-A	s MOUNTED CIRCUIT BOARD, HA
307	A-1133-996-A	s MOUNTED CIRCUIT BOARD, HB
308	△ X-2048-798-1	s BEZEL ASSY
309	X-2108-377-1	s MASK (16:9) ASSY
310	2-672-611-01	s KNOB, CONTROL
311	4-061-920-01	s INSULATOR, YC
312	4-382-854-51	s SCREW (M3X6), P, SW (+)
	7-685-646-79	s SCREW +BVTP 3X8 TYPE2 IT-3
	7-685-648-71	s SCREW +BVTP 3X12 TYPE2 IT-3

Picture Tube

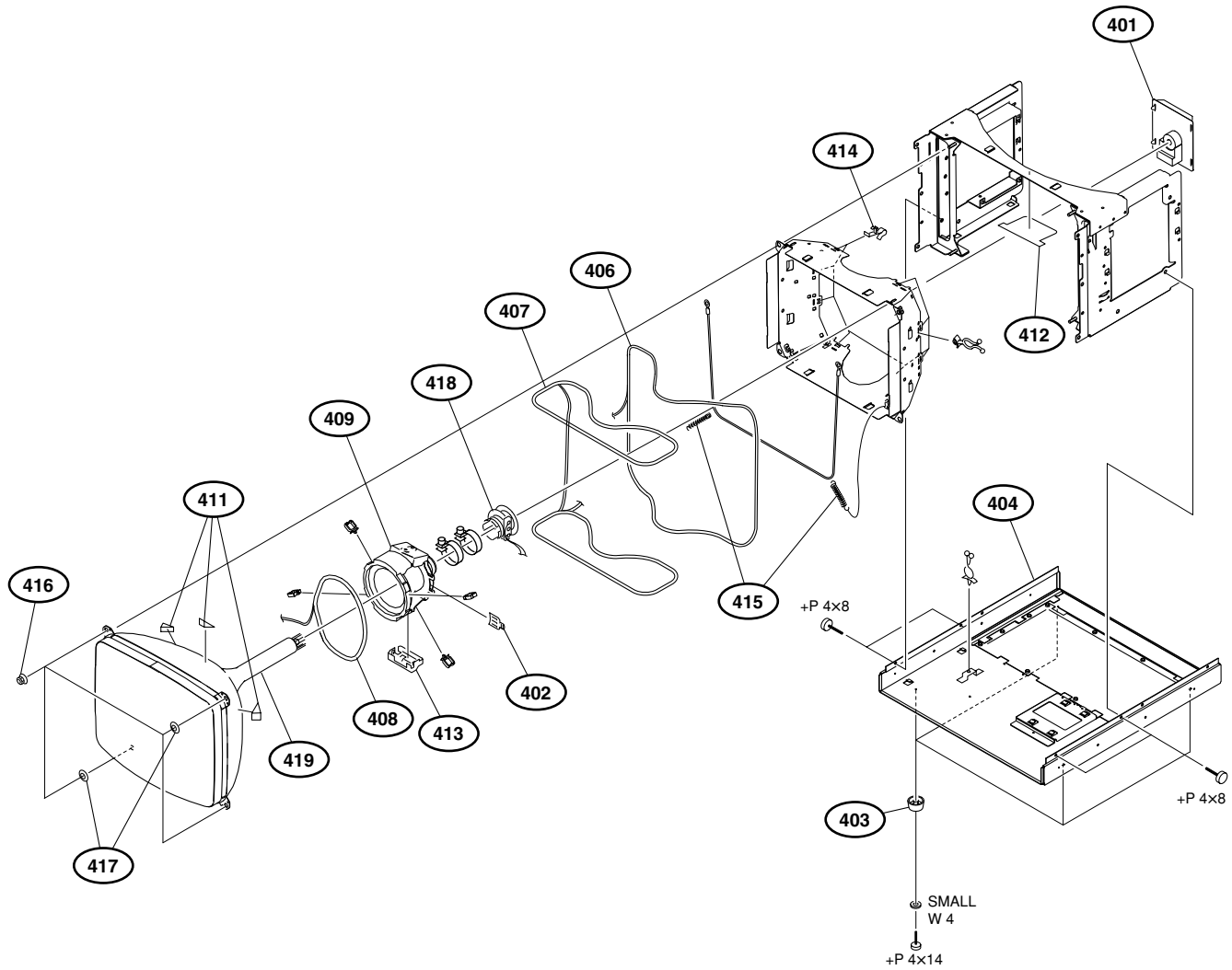

No.	Part No.	SP Description
401	A-1091-223-A	s MOUNTED CIRCUIT BOARD, C
402	X-2105-533-1	s PLATE ASSY, CORRECTION, TLH
403	X-4033-117-1	s FOOT ASSY
404	X-4033-129-6	s CHASSIS ASSY, BOTTOM
406	1-411-658-11	s COIL, LANDING CORRECTION
407	△ 1-411-660-21	s COIL, DEMAGNETIC
408	1-419-183-21	s COIL, NA ROTAION
409	△ 1-451-508-13	s DEFLECTION YOKE (Y14MPD-2)
411	4-050-492-03	s SPACER, DY
412	4-050-913-02	o INSULATOR (ANODE)
413	4-053-410-02	s SHIELD, DY
414	4-063-324-01	s HOLDER, LCC
415	4-303-774-03	s SPRING
416	4-306-034-01	s NUT, (B) (M5), FLANGE
417	4-348-567-01	s WASHER, CRT POSITION
418	1-452-436-41	s NECK ASSY, CRT (NA292)
419	△ 8-738-373-05	s PICTURE TUBE 14M21 (AE, AUS)
	△ 8-738-375-05	s PICTURE TUBE 14M23 (UC)
	7-682-161-09	s SCREW +P 4X8
	7-682-564-09	s SCREW +P 4X14
	7-688-004-02	o W 4, SMALL
	1-452-032-11	MAGNET, DISC
	4-051-736-23	PIECE A (90), CONV, CORRECT
	4-051-736-42	PIECE A (90), CONV, CORRECT

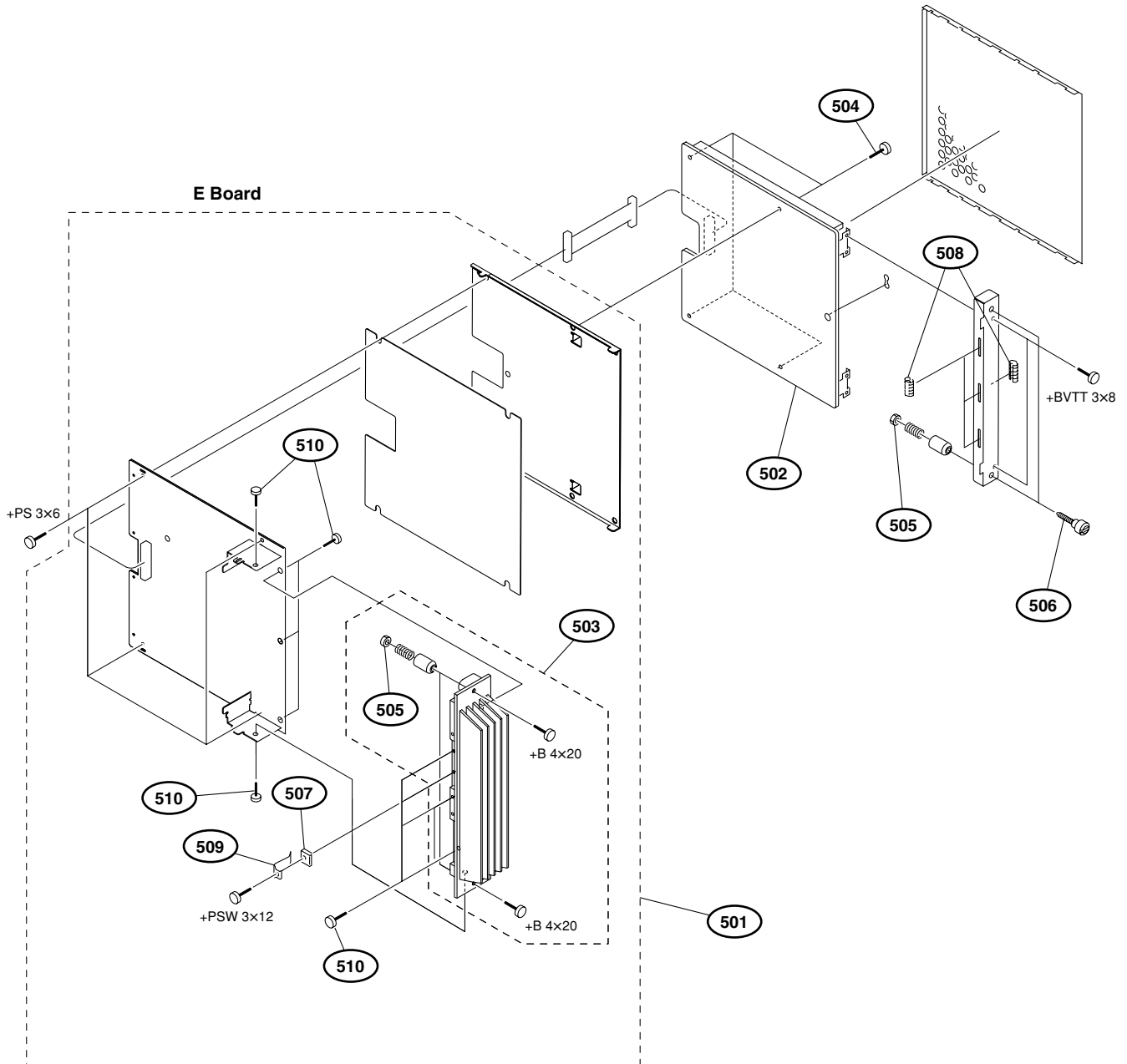

No.	Part No.	SP	Description
501	A-1091-417-A	s	MOUNTED CIRCUIT BOARD, E
502	A-1173-137-A	s	MOUNTED CIRCUIT BOARD, EA
503	X-4033-108-5	o	HEAT SINK ASSY, DEF
504	2-590-972-01	s	SCREW (M3X4), STEP
505	3-648-057-02	o	NUT (ISO-4), U
506	4-050-804-01	o	SCREW, PANEL STOPPER
507	4-072-202-01	o	SPACER
508	4-076-108-01	o	FINGER, SHIELD
509	4-381-905-01	o	SPRING (D)
510	4-382-854-01	s	SCREW (M3X8), P, SW (+)
	7-682-566-04	s	SCREW +B 4X20
	7-682-647-01	s	SCREW +PS 3X6
	7-682-950-01	s	SCREW +PSW 3X12
	7-685-872-01	s	SCREW +BVTT 3X8 (S)
	7-685-872-09	s	SCREW +BVTT 3X8 (S)

G Board

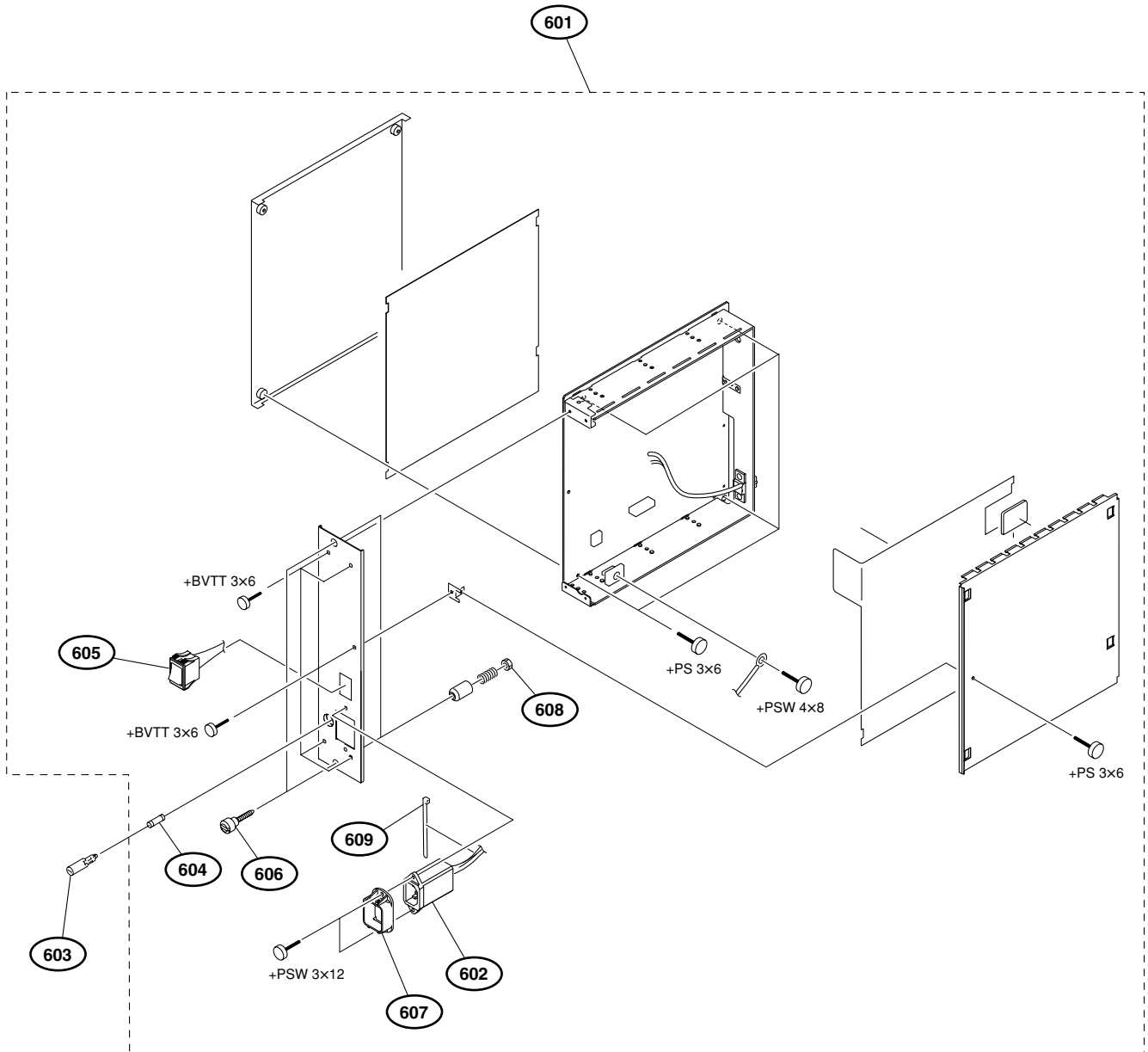

No.	Part No.	SP Description
601	A-1091-093-A	s MOUNTED CIRCUIT BOARD, G
602	△ 1-251-382-21	s INLET, AC 3P(WITH NOISE FILTER)
603	△ 1-533-702-11	s HOLDER, FUSE
604	△ 1-576-231-51	s FUSE (H, B, C) (4A.250V)
605	△ 1-762-300-11	s SWITCH, AC POWER SEESAW
606	4-050-804-01	o SCREW, PANEL STOPPER
607	2-990-241-02	s HOLDER (A), PLUG
608	3-648-057-02	o NUT (ISO-4), U
609	3-701-748-00	s CLAMP
	7-682-647-01	s SCREW +PS 3X6
	7-682-950-09	s SCREW +PSW 3X12
	7-682-961-01	s SCREW +PSW 4X8
	7-685-871-09	s SCREW +BVT 3X6 (S)

6-3. Electrical Parts List

BC BOARD

Ref. No. or Q'ty	Part No.	SP	Description
1pc	A-1171-143-A	s	MOUNTED CIRCUIT BOARD, BC
2pcs	3-648-057-00	o	NUT (ISO-4), U
2pcs	7-682-566-04	s	SCREW +B 4X20
2pcs	7-685-872-09	s	SCREW +BVTT 3X8 (S) (PANEL(2))
C011	1-100-566-91	s	CAP, CHIP CERAMIC 0.1MF B 1608
C012	1-100-566-91	s	CAP, CHIP CERAMIC 0.1MF B 1608
C013	1-162-970-91	s	CAP, CERAMIC 10000PF B 1608
C014	1-100-566-91	s	CAP, CHIP CERAMIC 0.1MF B 1608
C015	1-126-392-21	s	CAP, CHIP ELECT 100MF(6.3X5.7)
C016	1-100-566-91	s	CAP, CHIP CERAMIC 0.1MF B 1608
C017	1-162-970-91	s	CAP, CERAMIC 10000PF B 1608
C018	1-100-566-91	s	CAP, CHIP CERAMIC 0.1MF B 1608
C019	1-162-970-91	s	CAP, CERAMIC 10000PF B 1608
C020	1-100-566-91	s	CAP, CHIP CERAMIC 0.1MF B 1608
C021	1-100-566-91	s	CAP, CHIP CERAMIC 0.1MF B 1608
C022	1-100-566-91	s	CAP, CHIP CERAMIC 0.1MF B 1608
C023	1-126-412-21	s	CAP, CHIP ELECT 220MF (4X5.7)
C024	1-165-989-91	s	CAP, CERAMIC 10MF (2012)
C025	1-162-970-91	s	CAP, CERAMIC 10000PF B 1608
C026	1-162-970-91	s	CAP, CERAMIC 10000PF B 1608
C028	1-107-726-91	s	CAP,CHIP CERAMIC 10000PF B1608
C030	1-162-970-91	s	CAP, CERAMIC 10000PF B 1608
C031	1-162-970-91	s	CAP, CERAMIC 10000PF B 1608
C032	1-162-970-91	s	CAP, CERAMIC 10000PF B 1608
C033	1-162-910-91	s	CAP, CERAMIC 5.0PF CH 1608
C034	1-162-970-91	s	CAP, CERAMIC 10000PF B 1608
C037	1-164-315-91	s	CAP, CERAMIC 470PF CH (1608)
C039	1-164-315-91	s	CAP, CERAMIC 470PF CH (1608)
C043	1-162-970-91	s	CAP, CERAMIC 10000PF B 1608
C044	1-100-566-91	s	CAP, CHIP CERAMIC 0.1MF B 1608
C045	1-100-566-91	s	CAP, CHIP CERAMIC 0.1MF B 1608
C046	1-100-566-91	s	CAP, CHIP CERAMIC 0.1MF B 1608
C047	1-100-566-91	s	CAP, CHIP CERAMIC 0.1MF B 1608
C048	1-100-566-91	s	CAP, CHIP CERAMIC 0.1MF B 1608
C049	1-100-566-91	s	CAP, CHIP CERAMIC 0.1MF B 1608
C050	1-100-566-91	s	CAP, CHIP CERAMIC 0.1MF B 1608
C051	1-100-566-91	s	CAP, CHIP CERAMIC 0.1MF B 1608
C052	1-100-566-91	s	CAP, CHIP CERAMIC 0.1MF B 1608
C053	1-100-566-91	s	CAP, CHIP CERAMIC 0.1MF B 1608
C054	1-100-566-91	s	CAP, CHIP CERAMIC 0.1MF B 1608
C055	1-128-360-21	s	CAP, CHIP CELECT 220MF
C056	1-165-989-91	s	CAP, CERAMIC 10MF (2012)
C057	1-162-970-91	s	CAP, CERAMIC 10000PF B 1608
C100	1-165-989-91	s	CAP, CERAMIC 10MF (2012)
C101	1-165-989-91	s	CAP, CERAMIC 10MF (2012)
C102	1-162-970-91	s	CAP, CERAMIC 10000PF B 1608
C103	1-107-826-91	s	CAP, CHIP CERAMIC 100000PF B
C104	1-162-970-91	s	CAP, CERAMIC 10000PF B 1608
C105	1-162-970-91	s	CAP, CERAMIC 10000PF B 1608
C106	1-162-970-91	s	CAP, CERAMIC 10000PF B 1608
C107	1-162-970-91	s	CAP, CERAMIC 10000PF B 1608
C108	1-107-826-91	s	CAP, CHIP CERAMIC 100000PF B
C109	1-162-970-91	s	CAP, CERAMIC 10000PF B 1608
C110	1-162-970-91	s	CAP, CERAMIC 10000PF B 1608
C111	1-162-970-91	s	CAP, CERAMIC 10000PF B 1608
C112	1-126-392-21	s	CAP, CHIP ELECT 100MF(6.3X5.7)
C113	1-126-392-21	s	CAP, CHIP ELECT 100MF(6.3X5.7)
C114	1-162-970-91	s	CAP, CERAMIC 10000PF B 1608
C115	1-162-970-91	s	CAP, CERAMIC 10000PF B 1608
C116	1-162-970-91	s	CAP, CERAMIC 10000PF B 1608
C117	1-162-970-91	s	CAP, CERAMIC 10000PF B 1608

(BC BOARD)

Ref. No. or Q'ty	Part No.	SP	Description
C118	1-107-826-91	s	CAP, CHIP CERAMIC 100000PF B
C119	1-162-970-91	s	CAP, CERAMIC 10000PF B 1608
C120	1-107-826-91	s	CAP, CHIP CERAMIC 100000PF B
C121	1-162-970-91	s	CAP, CERAMIC 10000PF B 1608
C122	1-165-989-91	s	CAP, CERAMIC 10MF (2012)
C123	1-165-989-91	s	CAP, CERAMIC 10MF (2012)
C129	1-162-970-91	s	CAP, CERAMIC 10000PF B 1608
C130	1-165-989-91	s	CAP, CERAMIC 10MF (2012)
C131	1-162-970-91	s	CAP, CERAMIC 10000PF B 1608
C132	1-162-970-91	s	CAP, CERAMIC 10000PF B 1608
C133	1-162-970-91	s	CAP, CERAMIC 10000PF B 1608
C150	1-162-970-91	s	CAP, CERAMIC 10000PF B 1608
C151	1-126-392-21	s	CAP, CHIP ELECT 100MF(6.3X5.7)
C152	1-107-826-91	s	CAP, CHIP CERAMIC 100000PF B
C153	1-107-826-91	s	CAP, CHIP CERAMIC 100000PF B
C154	1-107-826-91	s	CAP, CHIP CERAMIC 100000PF B
C155	1-107-826-91	s	CAP, CHIP CERAMIC 100000PF B
C156	1-107-826-91	s	CAP, CHIP CERAMIC 100000PF B
C157	1-107-826-91	s	CAP, CHIP CERAMIC 100000PF B
C158	1-107-826-91	s	CAP, CHIP CERAMIC 100000PF B
C159	1-107-826-91	s	CAP, CHIP CERAMIC 100000PF B
C160	1-107-826-91	s	CAP, CHIP CERAMIC 100000PF B
C161	1-162-970-91	s	CAP, CERAMIC 10000PF B 1608
C162	1-162-970-91	s	CAP, CERAMIC 10000PF B 1608
C163	1-162-970-91	s	CAP, CERAMIC 10000PF B 1608
C164	1-107-826-91	s	CAP, CHIP CERAMIC 100000PF B
C165	1-107-826-91	s	CAP, CHIP CERAMIC 100000PF B
C166	1-162-970-91	s	CAP, CERAMIC 10000PF B 1608
C167	1-162-970-91	s	CAP, CERAMIC 10000PF B 1608
C168	1-162-970-91	s	CAP, CERAMIC 10000PF B 1608
C169	1-162-970-91	s	CAP, CERAMIC 10000PF B 1608
C170	1-107-826-91	s	CAP, CHIP CERAMIC 100000PF B
C171	1-107-826-91	s	CAP, CHIP CERAMIC 100000PF B
C172	1-162-970-91	s	CAP, CERAMIC 10000PF B 1608
C173	1-162-970-91	s	CAP, CERAMIC 10000PF B 1608
C174	1-162-970-91	s	CAP, CERAMIC 10000PF B 1608
C175	1-107-826-91	s	CAP, CHIP CERAMIC 100000PF B
C176	1-162-970-91	s	CAP, CERAMIC 10000PF B 1608
C177	1-162-970-91	s	CAP, CERAMIC 10000PF B 1608
C178	1-162-970-91	s	CAP, CERAMIC 10000PF B 1608
C179	1-107-826-91	s	CAP, CHIP CERAMIC 100000PF B
C180	1-162-970-91	s	CAP, CERAMIC 10000PF B 1608
C181	1-162-970-91	s	CAP, CERAMIC 10000PF B 1608
C182	1-107-826-91	s	CAP, CHIP CERAMIC 100000PF B
C183	1-107-826-91	s	CAP, CHIP CERAMIC 100000PF B
C184	1-107-826-91	s	CAP, CHIP CERAMIC 100000PF B
C185	1-107-726-91	s	CAP,CHIP CERAMIC 10000PF B1608
C186	1-107-726-91	s	CAP,CHIP CERAMIC 10000PF B1608
C187	1-107-726-91	s	CAP,CHIP CERAMIC 10000PF B1608
C188	1-107-726-91	s	CAP,CHIP CERAMIC 10000PF B1608
C189	1-107-726-91	s	CAP,CHIP CERAMIC 10000PF B1608
C190	1-107-726-91	s	CAP,CHIP CERAMIC 10000PF B1608
C191	1-107-726-91	s	CAP,CHIP CERAMIC 10000PF B1608
C192	1-107-726-91	s	CAP,CHIP CERAMIC 10000PF B1608
C193	1-126-392-21	s	CAP, CHIP ELECT 100MF(6.3X5.7)
C194	1-126-392-21	s	CAP, CHIP ELECT 100MF(6.3X5.7)
C195	1-126-392-21	s	CAP, CHIP ELECT 100MF(6.3X5.7)
C196	1-126-392-21	s	CAP, CHIP ELECT 100MF(6.3X5.7)
C197	1-126-392-21	s	CAP, CHIP ELECT 100MF(6.3X5.7)

(BC BOARD)

Ref. No. or Q'ty	Part No.	SP Description
C198	1-162-970-91	s CAP, CERAMIC 10000PF B 1608
C199	1-162-970-91	s CAP, CERAMIC 10000PF B 1608
C200	1-162-970-91	s CAP, CERAMIC 10000PF B 1608
C250	1-162-970-91	s CAP, CERAMIC 10000PF B 1608
C251	1-100-566-91	s CAP, CHIP CERAMIC 0.1MF B 1608
C252	1-100-566-91	s CAP, CHIP CERAMIC 0.1MF B 1608
C253	1-162-970-91	s CAP, CERAMIC 10000PF B 1608
C254	1-100-566-91	s CAP, CHIP CERAMIC 0.1MF B 1608
C255	1-100-566-91	s CAP, CHIP CERAMIC 0.1MF B 1608
C256	1-100-566-91	s CAP, CHIP CERAMIC 0.1MF B 1608
C257	1-100-566-91	s CAP, CHIP CERAMIC 0.1MF B 1608
C258	1-162-970-91	s CAP, CERAMIC 10000PF B 1608
C259	1-162-970-91	s CAP, CERAMIC 10000PF B 1608
C260	1-100-566-91	s CAP, CHIP CERAMIC 0.1MF B 1608
C261	1-100-566-91	s CAP, CHIP CERAMIC 0.1MF B 1608
C262	1-100-566-91	s CAP, CHIP CERAMIC 0.1MF B 1608
C263	1-100-566-91	s CAP, CHIP CERAMIC 0.1MF B 1608
C264	1-100-566-91	s CAP, CHIP CERAMIC 0.1MF B 1608
C265	1-100-566-91	s CAP, CHIP CERAMIC 0.1MF B 1608
C266	1-107-826-91	s CAP, CHIP CERAMIC 100000PF B
C267	1-107-826-91	s CAP, CHIP CERAMIC 100000PF B
C268	1-107-826-91	s CAP, CHIP CERAMIC 100000PF B
C269	1-107-826-91	s CAP, CHIP CERAMIC 100000PF B
C270	1-107-826-91	s CAP, CHIP CERAMIC 100000PF B
C271	1-107-726-91	s CAP,CHIP CERAMIC 10000PF B1608
C272	1-107-826-91	s CAP, CHIP CERAMIC 100000PF B
C273	1-107-826-91	s CAP, CHIP CERAMIC 100000PF B
C274	1-107-826-91	s CAP, CHIP CERAMIC 100000PF B
C275	1-107-826-91	s CAP, CHIP CERAMIC 100000PF B
C276	1-107-826-91	s CAP, CHIP CERAMIC 100000PF B
C277	1-126-392-21	s CAP, CHIP ELECT 100MF (6.3X5.7)
C278	1-126-392-21	s CAP, CHIP ELECT 100MF (6.3X5.7)
C279	1-126-392-21	s CAP, CHIP ELECT 100MF (6.3X5.7)
C280	1-126-392-21	s CAP, CHIP ELECT 100MF (6.3X5.7)
C281	1-126-392-21	s CAP, CHIP ELECT 100MF (6.3X5.7)
C282	1-162-964-91	s CAP,CHIP CERAMIC 1000PF B 1608
C283	1-100-566-91	s CAP, CHIP CERAMIC 0.1MF B 1608
C284	1-100-566-91	s CAP, CHIP CERAMIC 0.1MF B 1608
C290	1-107-826-91	s CAP, CHIP CERAMIC 100000PF B
C300	1-100-566-91	s CAP, CHIP CERAMIC 0.1MF B 1608
C301	1-131-661-21	s CAP, CHIP ELECT 100MF (6.3X5.7)
C302	1-162-970-91	s CAP, CERAMIC 10000PF B 1608
C304	1-162-970-91	s CAP, CERAMIC 10000PF B 1608
C305	1-162-970-91	s CAP, CERAMIC 10000PF B 1608
C306	1-162-970-91	s CAP, CERAMIC 10000PF B 1608
C307	1-162-970-91	s CAP, CERAMIC 10000PF B 1608
C308	1-162-970-91	s CAP, CERAMIC 10000PF B 1608
C309	1-162-970-91	s CAP, CERAMIC 10000PF B 1608
C310	1-162-970-91	s CAP, CERAMIC 10000PF B 1608
C311	1-162-970-91	s CAP, CERAMIC 10000PF B 1608
C312	1-162-970-91	s CAP, CERAMIC 10000PF B 1608
C313	1-100-566-91	s CAP, CHIP CERAMIC 0.1MF B 1608
C314	1-100-566-91	s CAP, CHIP CERAMIC 0.1MF B 1608
C315	1-100-566-91	s CAP, CHIP CERAMIC 0.1MF B 1608
C316	1-100-566-91	s CAP, CHIP CERAMIC 0.1MF B 1608
C317	1-100-566-91	s CAP, CHIP CERAMIC 0.1MF B 1608
C318	1-100-566-91	s CAP, CHIP CERAMIC 0.1MF B 1608
C319	1-100-566-91	s CAP, CHIP CERAMIC 0.1MF B 1608
C320	1-100-566-91	s CAP, CHIP CERAMIC 0.1MF B 1608

(BC BOARD)

Ref. No. or Q'ty	Part No.	SP Description
C321	1-100-566-91	s CAP, CHIP CERAMIC 0.1MF B 1608
C322	1-100-566-91	s CAP, CHIP CERAMIC 0.1MF B 1608
C323	1-126-412-21	s CAP, CHIP ELECT 220MF (4X5.7)
C324	1-126-392-21	s CAP, CHIP ELECT 100MF (6.3X5.7)
C325	1-100-566-91	s CAP, CHIP CERAMIC 0.1MF B 1608
C326	1-100-566-91	s CAP, CHIP CERAMIC 0.1MF B 1608
C327	1-162-970-91	s CAP, CERAMIC 10000PF B 1608
C328	1-100-566-91	s CAP, CHIP CERAMIC 0.1MF B 1608
C329	1-100-566-91	s CAP, CHIP CERAMIC 0.1MF B 1608
C340	1-162-970-91	s CAP, CERAMIC 10000PF B 1608
C341	1-162-970-91	s CAP, CERAMIC 10000PF B 1608
C342	1-162-970-91	s CAP, CERAMIC 10000PF B 1608
C350	1-162-970-91	s CAP, CERAMIC 10000PF B 1608
C351	1-162-923-91	s CAP, CERAMIC 47PF CH 1608
C352	1-100-566-91	s CAP, CHIP CERAMIC 0.1MF B 1608
C353	1-125-889-91	s CAP, CHIP CERAMIC 2.2MF B 2012
C354	1-162-970-91	s CAP, CERAMIC 10000PF B 1608
C355	1-164-315-91	s CAP, CERAMIC 470PF CH (1608)
C356	1-162-925-91	s CAP, CERAMIC 68PF CH 1608
C357	1-162-966-91	s CAP, CERAMIC 2200PF B 1608
C358	1-162-966-91	s CAP, CERAMIC 2200PF B 1608
C359	1-162-925-91	s CAP, CERAMIC 68PF CH 1608
C360	1-164-315-91	s CAP, CERAMIC 470PF CH (1608)
C361	1-162-966-91	s CAP, CERAMIC 2200PF B 1608
C362	1-162-966-91	s CAP, CERAMIC 2200PF B 1608
C363	1-164-315-91	s CAP, CERAMIC 470PF CH (1608)
C364	1-100-566-91	s CAP, CHIP CERAMIC 0.1MF B 1608
C365	1-100-566-91	s CAP, CHIP CERAMIC 0.1MF B 1608
C366	1-100-566-91	s CAP, CHIP CERAMIC 0.1MF B 1608
C367	1-100-566-91	s CAP, CHIP CERAMIC 0.1MF B 1608
C368	1-162-970-91	s CAP, CERAMIC 10000PF B 1608
C369	1-127-820-91	s CAP, CHIP CERAMIC 4.7MF B 3216
C370	1-127-692-91	s CAP, CHIP CERAMIC 10MF B 3225
C371	1-127-692-91	s CAP, CHIP CERAMIC 10MF B 3225
C372	1-127-692-91	s CAP, CHIP CERAMIC 10MF B 3225
C373	1-165-667-21	s CAP, ELECT 100MF
C374	1-165-668-21	s CAP, ELECT 150MF
C375	1-162-970-91	s CAP, CERAMIC 10000PF B 1608
C376	1-162-970-91	s CAP, CERAMIC 10000PF B 1608
C377	1-162-970-91	s CAP, CERAMIC 10000PF B 1608
C378	1-135-344-21	s CAP, ELECT 270MF (10X8)
C379	1-135-344-21	s CAP, ELECT 270MF (10X8)
C380	1-126-392-21	s CAP, CHIP ELECT 100MF (6.3X5.7)
C381	1-162-970-91	s CAP, CERAMIC 10000PF B 1608
C382	1-100-566-91	s CAP, CHIP CERAMIC 0.1MF B 1608
C383	1-126-391-21	s CAP, CHIP ELECT 47MF (5X5.7)
C384	1-100-566-91	s CAP, CHIP CERAMIC 0.1MF B 1608
C385	1-126-412-21	s CAP, CHIP ELECT 220MF (4X5.7)
C386	1-100-566-91	s CAP, CHIP CERAMIC 0.1MF B 1608
C387	1-165-585-21	s CAP, CHIP ELECT 47MF
C388	1-100-566-91	s CAP, CHIP CERAMIC 0.1MF B 1608
C389	1-126-396-21	s CAP, CHIP ELECT 47MF (6.3X5.7)
C390	1-100-566-91	s CAP, CHIP CERAMIC 0.1MF B 1608
C391	1-131-661-21	s CAP, CHIP ELECT 100MF (6.3X5.7)
C392	1-100-566-91	s CAP, CHIP CERAMIC 0.1MF B 1608
C396	1-126-390-21	s CAP, CHIP ELECT 22MF (4X5.7)
C398	1-100-566-91	s CAP, CHIP CERAMIC 0.1MF B 1608
C399	1-100-202-21	s CAP, CHIP ELECT 330MF
C400	1-100-202-21	s CAP, CHIP ELECT 330MF

(BC BOARD)

Ref. No. or Q'ty	Part No.	SP	Description
CN011	1-774-137-11	s	SOCKET, CONNECTOR 36P
CN150	1-817-753-11	o	CONNECTOR, BOARD TO BOARD 100P
CN151	1-764-080-21	o	PIN, CONNECTOR (PC BOARD) 8P
CN152	1-817-753-11	o	CONNECTOR, BOARD TO BOARD 100P
CN153	1-573-566-11	s	CONNECTOR, D-SUB (ANGLE TYPE) 9P
CN250	1-815-187-11	s	JACK, MODULAR
CN251	1-784-427-11	s	CONNECTOR, D-SUB (ANGLE TYPE) 9
CN350	1-770-469-21	o	PIN, CONNECTOR (PC BOARD) 2P
CN351	1-770-469-21	o	PIN, CONNECTOR (PC BOARD) 2P
D011	8-719-038-07	s	DIODE CL-190PG-CD-T
D012	8-719-038-07	s	DIODE CL-190PG-CD-T
D013	8-719-038-07	s	DIODE CL-190PG-CD-T
D014	6-501-156-01	s	DIODE LB-303DA
D015	8-719-038-07	s	DIODE CL-190PG-CD-T
D154	8-719-037-22	s	DIODE RD12SB-T1
D155	8-719-037-22	s	DIODE RD12SB-T1
D156	8-719-037-22	s	DIODE RD12SB-T1
D157	8-719-037-22	s	DIODE RD12SB-T1
D158	8-719-037-22	s	DIODE RD12SB-T1
D159	8-719-037-22	s	DIODE RD12SB-T1
D160	8-719-036-98	s	DIODE RD6.2SB-T1
D161	8-719-036-98	s	DIODE RD6.2SB-T1
D162	8-719-036-98	s	DIODE RD6.2SB-T1
D163	8-719-036-98	s	DIODE RD6.2SB-T1
D164	8-719-036-98	s	DIODE RD6.2SB-T1
D165	8-719-036-98	s	DIODE RD6.2SB-T1
D166	8-719-036-98	s	DIODE RD6.2SB-T1
D167	8-719-036-98	s	DIODE RD6.2SB-T1
D168	8-719-036-98	s	DIODE RD6.2SB-T1
D251	8-719-037-22	s	DIODE RD12SB-T1
D252	8-719-037-22	s	DIODE RD12SB-T1
D253	8-719-037-22	s	DIODE RD12SB-T1
D254	8-719-037-22	s	DIODE RD12SB-T1
D255	8-719-037-22	s	DIODE RD12SB-T1
D256	8-719-037-22	s	DIODE RD12SB-T1
D257	8-719-037-22	s	DIODE RD12SB-T1
D258	8-719-037-22	s	DIODE RD12SB-T1
D350	8-719-027-76	s	DIODE 1SS357-TPH3
D351	8-719-027-76	s	DIODE 1SS357-TPH3
D352	8-719-073-92	s	DIODE RB060L-40TE25
D353	8-719-073-92	s	DIODE RB060L-40TE25
D354	8-719-404-50	s	DIODE MA111-TX
D355	8-719-404-50	s	DIODE MA111-TX
D356	8-719-404-50	s	DIODE MA111-TX
D357	8-719-404-50	s	DIODE MA111-TX
D358	8-719-036-98	s	DIODE RD6.2SB-T1
D359	8-719-404-50	s	DIODE MA111-TX
D360	8-719-404-50	s	DIODE MA111-TX
D361	8-719-038-07	s	DIODE CL-190PG-CD-T
D362	8-719-404-50	s	DIODE MA111-TX
F350	1-533-804-21	s	FUSE (SMD) (2.5A/125V)
F351	1-533-804-21	s	FUSE (SMD) (2.5A/125V)
F352	1-533-804-21	s	FUSE (SMD) (2.5A/125V)
FB011	1-414-864-21	s	FERRITE, EMI (SMD) (1608)
FB012	1-414-864-21	s	FERRITE, EMI (SMD) (1608)
FB013	1-414-864-21	s	FERRITE, EMI (SMD) (1608)
FB014	1-414-864-21	s	FERRITE, EMI (SMD) (1608)
FB015	1-414-864-21	s	FERRITE, EMI (SMD) (1608)

(BC BOARD)

Ref. No. or Q'ty	Part No.	SP	Description
FB016	1-414-864-21	s	FERRITE, EMI (SMD) (1608)
FB017	1-414-864-21	s	FERRITE, EMI (SMD) (1608)
FB018	1-414-864-21	s	FERRITE, EMI (SMD) (1608)
FB019	1-414-864-21	s	FERRITE, EMI (SMD) (1608)
FB020	1-414-864-21	s	FERRITE, EMI (SMD) (1608)
FB021	1-414-864-21	s	FERRITE, EMI (SMD) (1608)
FB100	1-414-864-21	s	FERRITE, EMI (SMD) (1608)
FB101	1-414-864-21	s	FERRITE, EMI (SMD) (1608)
FB102	1-414-864-21	s	FERRITE, EMI (SMD) (1608)
FB103	1-414-864-21	s	FERRITE, EMI (SMD) (1608)
FB105	1-414-864-21	s	FERRITE, EMI (SMD) (1608)
FB106	1-414-864-21	s	FERRITE, EMI (SMD) (1608)
FB107	1-414-864-21	s	FERRITE, EMI (SMD) (1608)
FB108	1-414-864-21	s	FERRITE, EMI (SMD) (1608)
FB150	1-414-864-21	s	FERRITE, EMI (SMD) (1608)
FB151	1-414-864-21	s	FERRITE, EMI (SMD) (1608)
FB152	1-414-864-21	s	FERRITE, EMI (SMD) (1608)
FB153	1-414-864-21	s	FERRITE, EMI (SMD) (1608)
FB154	1-414-864-21	s	FERRITE, EMI (SMD) (1608)
FB155	1-414-864-21	s	FERRITE, EMI (SMD) (1608)
FB156	1-414-864-21	s	FERRITE, EMI (SMD) (1608)
FB157	1-414-864-21	s	FERRITE, EMI (SMD) (1608)
FB158	1-414-864-21	s	FERRITE, EMI (SMD) (1608)
FB159	1-414-864-21	s	FERRITE, EMI (SMD) (1608)
FB160	1-414-864-21	s	FERRITE, EMI (SMD) (1608)
FB161	1-414-864-21	s	FERRITE, EMI (SMD) (1608)
FB162	1-414-864-21	s	FERRITE, EMI (SMD) (1608)
FB163	1-414-864-21	s	FERRITE, EMI (SMD) (1608)
FB164	1-414-864-21	s	FERRITE, EMI (SMD) (1608)
FB165	1-414-864-21	s	FERRITE, EMI (SMD) (1608)
FB166	1-414-864-21	s	FERRITE, EMI (SMD) (1608)
FB167	1-414-864-21	s	FERRITE, EMI (SMD) (1608)
FB168	1-414-864-21	s	FERRITE, EMI (SMD) (1608)
FB169	1-414-864-21	s	FERRITE, EMI (SMD) (1608)
FB170	1-414-864-21	s	FERRITE, EMI (SMD) (1608)
FB171	1-414-864-21	s	FERRITE, EMI (SMD) (1608)
FB250	1-414-864-21	s	FERRITE, EMI (SMD) (1608)
FB251	1-414-864-21	s	FERRITE, EMI (SMD) (1608)
FB252	1-414-864-21	s	FERRITE, EMI (SMD) (1608)
FB253	1-414-864-21	s	FERRITE, EMI (SMD) (1608)
FB254	1-414-864-21	s	FERRITE, EMI (SMD) (1608)
FB255	1-414-864-21	s	FERRITE, EMI (SMD) (1608)
FB256	1-414-864-21	s	FERRITE, EMI (SMD) (1608)
FB257	1-414-864-21	s	FERRITE, EMI (SMD) (1608)
FB258	1-414-864-21	s	FERRITE, EMI (SMD) (1608)
FB259	1-414-864-21	s	FERRITE, EMI (SMD) (1608)
FB301	1-414-864-21	s	FERRITE, EMI (SMD) (1608)
FB302	1-414-864-21	s	FERRITE, EMI (SMD) (1608)
FB303	1-414-864-21	s	FERRITE, EMI (SMD) (1608)
FB304	1-414-864-21	s	FERRITE, EMI (SMD) (1608)
FB305	1-414-864-21	s	FERRITE, EMI (SMD) (1608)
FB350	1-469-379-21	s	FERRITE, EMI (SMD) (2012)
FB403	1-400-150-21	s	FERRITE, EMI (SMD) (4516)
FL150	1-239-896-22	s	FILTER, EMI (SMD)
FL151	1-239-896-22	s	FILTER, EMI (SMD)
FL152	1-239-896-22	s	FILTER, EMI (SMD)
FL153	1-239-896-22	s	FILTER, EMI (SMD)
FL154	1-239-896-22	s	FILTER, EMI (SMD)

(BC BOARD)

Ref. No. or Q'ty	Part No.	SP Description
FL155	1-239-896-22	s FILTER, EMI (SMD)
FL156	1-239-896-22	s FILTER, EMI (SMD)
FL157	1-239-896-22	s FILTER, EMI (SMD)
FL158	1-239-896-22	s FILTER, EMI (SMD)
FL159	1-239-896-22	s FILTER, EMI (SMD)
FL160	1-239-896-22	s FILTER, EMI (SMD)
FL161	1-239-896-22	s FILTER, EMI (SMD)
FL162	1-239-896-22	s FILTER, EMI (SMD)
FL163	1-239-896-22	s FILTER, EMI (SMD)
FL164	1-239-896-22	s FILTER, EMI (SMD)
FL165	1-239-896-22	s FILTER, EMI (SMD)
FL166	1-239-896-22	s FILTER, EMI (SMD)
FL167	1-239-896-22	s FILTER, EMI (SMD)
FL168	1-239-896-22	s FILTER, EMI (SMD)
FL169	1-239-896-22	s FILTER, EMI (SMD)
FL170	1-239-896-22	s FILTER, EMI (SMD)
FL250	1-239-896-22	s FILTER, EMI (SMD)
FL251	1-239-896-22	s FILTER, EMI (SMD)
FL252	1-239-896-22	s FILTER, EMI (SMD)
FL253	1-239-896-22	s FILTER, EMI (SMD)
IC001	6-704-560-01	s IC HD6417709SF133BV
IC010	6-708-677-01	s IC BU4815FVE-TR
IC011	8-759-099-44	s IC TD62381FG (EL)
IC012	6-708-748-01	s IC BD4828FVE-TR
IC013	6-709-531-01	s IC TD62783AFG (5.S.EL)
IC014	8-759-679-54	s IC SN74LVC14APWR
IC015	6-703-875-01	s IC CDCVF2505PWR
IC016	8-759-573-97	s IC SN74LVC541APWR
IC017	8-759-592-46	s IC TC7SZ05FU (TE85R)
IC018	8-759-592-46	s IC TC7SZ05FU (TE85R)
IC100	6-705-755-01	s IC K4S561632E-UC75T
IC101	6-705-755-01	s IC K4S561632E-UC75T
IC106	6-707-987-01	s IC MB85R256PF-G-BNDE1
IC108	6-708-390-01	s IC SN74AUP1G14DCKR
IC109	6-708-389-01	s IC SN74AUP1G32DCKR
IC110	6-708-389-01	s IC SN74AUP1G32DCKR
IC150	6-709-436-01	s IC LC4128V-5TN100CA1353
IC151	8-759-573-97	s IC SN74LVC541APWR
IC152	8-759-573-97	s IC SN74LVC541APWR
IC153	8-759-592-49	s IC TC7SZ125FU (TE85R)
IC154	8-759-573-97	s IC SN74LVC541APWR
IC155	8-759-573-97	s IC SN74LVC541APWR
IC156	8-759-679-54	s IC SN74LVC14APWR
IC157	8-759-679-54	s IC SN74LVC14APWR
IC158	8-759-679-54	s IC SN74LVC14APWR
IC159	8-759-679-54	s IC SN74LVC14APWR
IC160	8-759-573-97	s IC SN74LVC541APWR
IC161	8-759-573-97	s IC SN74LVC541APWR
IC162	8-759-679-54	s IC SN74LVC14APWR
IC163	8-759-679-54	s IC SN74LVC14APWR
IC164	8-759-573-97	s IC SN74LVC541APWR
IC165	8-759-679-54	s IC SN74LVC14APWR
IC166	8-759-679-54	s IC SN74LVC14APWR
IC167	8-759-679-54	s IC SN74LVC14APWR
IC168	6-704-722-02	s IC XC9536XL-5VQG44C
IC250	6-706-488-01	s IC TC7SH14FU (T5RSOYJF)
IC251	6-705-039-01	s IC 93LC46BT-I/SN
IC253	8-759-429-23	s IC TL16C550CPT
IC254	6-700-424-01	s IC MAX3243CDBR

(BC BOARD)

Ref. No. or Q'ty	Part No.	SP Description
IC255	6-700-424-01	s IC MAX3243CDBR
IC256	6-706-488-01	s IC TC7SH14FU (T5RSOYJF)
IC257	6-706-488-01	s IC TC7SH14FU (T5RSOYJF)
IC301	6-700-387-01	s IC EPC2LC20N-TP
IC302	6-706-488-01	s IC TC7SH14FU (T5RSOYJF)
IC303	6-706-488-01	s IC TC7SH14FU (T5RSOYJF)
IC310	6-708-748-01	s IC BD4828FVE-TR
IC311	6-706-488-01	s IC TC7SH14FU (T5RSOYJF)
IC312	8-759-592-46	s IC TC7SZ05FU (TE85R)
IC313	8-759-523-04	s IC TC74HC4538AFT (EL)
IC350	6-702-510-01	s IC TPS5120DBTRG4
IC351	6-705-403-01	s IC PQ070XZ01ZPH
IC352	6-702-295-01	s IC NJM78M12DL1A-TE1
IC404	6-705-027-01	s IC BD4840FVE-TR
L350	1-469-848-21	s INDUCTOR (SMD)
L351	1-469-848-21	s INDUCTOR (SMD)
L352	1-469-848-21	s INDUCTOR (SMD)
L353	1-469-848-21	s INDUCTOR (SMD)
L354	1-469-848-21	s INDUCTOR (SMD)
Q150	8-729-209-77	s TRANSISTOR 2SC2873Y-TE12L
Q151	8-729-029-04	s TRANSISTOR DTC123JUA-T106
Q152	8-729-029-04	s TRANSISTOR DTC123JUA-T106
Q153	8-729-029-04	s TRANSISTOR DTC123JUA-T106
Q351	6-550-374-01	s TRANSISTOR TPC8009-H (T2LSONYF)
Q353	6-550-374-01	s TRANSISTOR TPC8009-H (T2LSONYF)
Q354	6-550-374-01	s TRANSISTOR TPC8009-H (T2LSONYF)
Q356	6-550-374-01	s TRANSISTOR TPC8009-H (T2LSONYF)
Q358	8-729-026-53	s TRANSISTOR 2SA1576A-T106-QR
Q360	8-729-029-14	s TRANSISTOR DTC144EUA-T106
Q362	8-729-029-14	s TRANSISTOR DTC144EUA-T106
Q363	8-729-029-14	s TRANSISTOR DTC144EUA-T106
Q364	8-729-028-91	s TRANSISTOR DTA144EUA-T106
Q365	8-729-029-14	s TRANSISTOR DTC144EUA-T106
Q366	8-729-028-91	s TRANSISTOR DTA144EUA-T106
Q367	8-729-029-14	s TRANSISTOR DTC144EUA-T106
Q382	8-729-905-38	s TRANSISTOR 2SC4081T106R
Q383	8-729-209-77	s TRANSISTOR 2SC2873Y-TE12L
R011	1-216-829-91	s RES, CHIP 4.7K (1608)
R012	1-216-833-91	s RES, CHIP 10K (1608)
R013	1-216-824-91	s RES, CHIP 1.8K (1608)
R014	1-216-801-91	s RES, CHIP 22 (1608)
R015	1-216-801-91	s RES, CHIP 22 (1608)
R016	1-216-824-91	s RES, CHIP 1.8K (1608)
R017	1-216-829-91	s RES, CHIP 4.7K (1608)
R018	1-216-824-91	s RES, CHIP 1.8K (1608)
R019	1-216-833-91	s RES, CHIP 10K (1608)
R020	1-216-821-91	s RES, CHIP 1.0K (1608)
R021	1-216-825-91	s RES, CHIP 2.2K (1608)
R022	1-216-807-91	s RES, CHIP 68 (1608)
R023	1-216-801-91	s RES, CHIP 22 (1608)
R024	1-216-824-91	s RES, CHIP 1.8K (1608)
R025	1-216-801-91	s RES, CHIP 22 (1608)
R026	1-216-801-91	s RES, CHIP 22 (1608)
R027	1-216-809-91	s RES, CHIP 100 (1608)
R028	1-216-805-91	s RES, CHIP 47 (1608)
R029	1-216-805-91	s RES, CHIP 47 (1608)
R030	1-216-805-91	s RES, CHIP 47 (1608)
R031	1-216-805-91	s RES, CHIP 47 (1608)

(BC BOARD)

Ref. No. or Q'ty	Part No.	SP	Description
R032	1-216-803-91	s RES,	CHIP 33 (1608)
R034	1-216-807-91	s RES,	CHIP 68 (1608)
R035	1-216-803-91	s RES,	CHIP 33 (1608)
R036	1-216-803-91	s RES,	CHIP 33 (1608)
R037	1-216-817-91	s RES,	CHIP 470 (1608)
R038	1-216-817-91	s RES,	CHIP 470 (1608)
R039	1-216-817-91	s RES,	CHIP 470 (1608)
R040	1-216-817-91	s RES,	CHIP 470 (1608)
R041	1-216-817-91	s RES,	CHIP 470 (1608)
R042	1-216-817-91	s RES,	CHIP 470 (1608)
R043	1-216-817-91	s RES,	CHIP 470 (1608)
R044	1-216-817-91	s RES,	CHIP 470 (1608)
R045	1-216-825-91	s RES,	CHIP 2.2K (1608)
R046	1-216-825-91	s RES,	CHIP 2.2K (1608)
R047	1-216-825-91	s RES,	CHIP 2.2K (1608)
R049	1-216-864-91	s CONDUCTOR,	CHIP (1608)
R100	1-216-833-91	s RES,	CHIP 10K (1608)
R101	1-216-833-91	s RES,	CHIP 10K (1608)
R102	1-216-833-91	s RES,	CHIP 10K (1608)
R103	1-216-833-91	s RES,	CHIP 10K (1608)
R113	1-216-805-91	s RES,	CHIP 47 (1608)
R114	1-216-805-91	s RES,	CHIP 47 (1608)
R115	1-216-833-91	s RES,	CHIP 10K (1608)
R116	1-216-801-91	s RES,	CHIP 22 (1608)
R151	1-216-833-91	s RES,	CHIP 10K (1608)
R152	1-216-864-91	s CONDUCTOR,	CHIP (1608)
R153	1-216-820-91	s RES,	CHIP 820 (1608)
R154	1-216-823-91	s RES,	CHIP 1.5K (1608)
R155	1-216-819-91	s RES,	CHIP 680 (1608)
R156	1-216-831-91	s RES,	CHIP 6.8K (1608)
R157	1-216-805-91	s RES,	CHIP 47 (1608)
R158	1-216-805-91	s RES,	CHIP 47 (1608)
R159	1-216-805-91	s RES,	CHIP 47 (1608)
R160	1-216-805-91	s RES,	CHIP 47 (1608)
R161	1-216-821-91	s RES,	CHIP 1.0K (1608)
R162	1-216-821-91	s RES,	CHIP 1.0K (1608)
R163	1-216-821-91	s RES,	CHIP 1.0K (1608)
R164	1-216-821-91	s RES,	CHIP 1.0K (1608)
R165	1-216-821-91	s RES,	CHIP 1.0K (1608)
R166	1-216-821-91	s RES,	CHIP 1.0K (1608)
R167	1-216-821-91	s RES,	CHIP 1.0K (1608)
R168	1-216-821-91	s RES,	CHIP 1.0K (1608)
R169	1-216-805-91	s RES,	CHIP 47 (1608)
R171	1-216-805-91	s RES,	CHIP 47 (1608)
R172	1-216-805-91	s RES,	CHIP 47 (1608)
R173	1-216-805-91	s RES,	CHIP 47 (1608)
R174	1-216-805-91	s RES,	CHIP 47 (1608)
R175	1-216-803-91	s RES,	CHIP 33 (1608)
R176	1-216-803-91	s RES,	CHIP 33 (1608)
R177	1-216-805-91	s RES,	CHIP 47 (1608)
R178	1-216-805-91	s RES,	CHIP 47 (1608)
R179	1-216-805-91	s RES,	CHIP 47 (1608)
R180	1-216-833-91	s RES,	CHIP 10K (1608)
R181	1-216-829-91	s RES,	CHIP 4.7K (1608)
R182	1-216-833-91	s RES,	CHIP 10K (1608)
R183	1-216-833-91	s RES,	CHIP 10K (1608)
R184	1-216-803-91	s RES,	CHIP 33 (1608)
R185	1-216-803-91	s RES,	CHIP 33 (1608)
R186	1-216-803-91	s RES,	CHIP 33 (1608)

(BC BOARD)

Ref. No. or Q'ty	Part No.	SP	Description
R187	1-216-803-91	s RES,	CHIP 33 (1608)
R188	1-216-825-91	s RES,	CHIP 2.2K (1608)
R189	1-216-825-91	s RES,	CHIP 2.2K (1608)
R190	1-216-825-91	s RES,	CHIP 2.2K (1608)
R191	1-216-864-91	s CONDUCTOR,	CHIP (1608)
R192	1-216-864-91	s CONDUCTOR,	CHIP (1608)
R193	1-216-864-91	s CONDUCTOR,	CHIP (1608)
R194	1-216-807-91	s RES,	CHIP 68 (1608)
R195	1-216-807-91	s RES,	CHIP 68 (1608)
R196	1-216-807-91	s RES,	CHIP 68 (1608)
R197	1-216-807-91	s RES,	CHIP 68 (1608)
R198	1-216-807-91	s RES,	CHIP 68 (1608)
R199	1-216-807-91	s RES,	CHIP 68 (1608)
R200	1-216-807-91	s RES,	CHIP 68 (1608)
R201	1-216-807-91	s RES,	CHIP 68 (1608)
R202	1-216-807-91	s RES,	CHIP 68 (1608)
R203	1-216-807-91	s RES,	CHIP 68 (1608)
R204	1-216-807-91	s RES,	CHIP 68 (1608)
R205	1-216-807-91	s RES,	CHIP 68 (1608)
R206	1-216-807-91	s RES,	CHIP 68 (1608)
R207	1-216-807-91	s RES,	CHIP 68 (1608)
R208	1-216-807-91	s RES,	CHIP 68 (1608)
R209	1-216-807-91	s RES,	CHIP 68 (1608)
R210	1-216-807-91	s RES,	CHIP 68 (1608)
R211	1-216-807-91	s RES,	CHIP 68 (1608)
R212	1-216-807-91	s RES,	CHIP 68 (1608)
R213	1-216-812-91	s RES,	CHIP 180 (1608)
R214	1-216-812-91	s RES,	CHIP 180 (1608)
R215	1-216-812-91	s RES,	CHIP 180 (1608)
R216	1-216-812-91	s RES,	CHIP 180 (1608)
R217	1-216-812-91	s RES,	CHIP 180 (1608)
R218	1-216-812-91	s RES,	CHIP 180 (1608)
R219	1-216-812-91	s RES,	CHIP 180 (1608)
R220	1-216-812-91	s RES,	CHIP 180 (1608)
R250	1-216-809-91	s RES,	CHIP 100 (1608)
R251	1-216-801-91	s RES,	CHIP 22 (1608)
R252	1-216-801-91	s RES,	CHIP 22 (1608)
R257	1-218-872-91	s RES,	CHIP 11K (1608)
R258	1-216-809-91	s RES,	CHIP 100 (1608)
R259	1-216-799-91	s RES,	CHIP 15 (1608)
R260	1-216-797-91	s RES,	CHIP 10 (1608)
R261	1-216-809-91	s RES,	CHIP 100 (1608)
R262	1-216-799-91	s RES,	CHIP 15 (1608)
R263	1-216-797-91	s RES,	CHIP 10 (1608)
R264	1-216-809-91	s RES,	CHIP 100 (1608)
R265	1-216-797-91	s RES,	CHIP 10 (1608)
R266	1-216-797-91	s RES,	CHIP 10 (1608)
R267	1-216-809-91	s RES,	CHIP 100 (1608)
R268	1-216-799-91	s RES,	CHIP 15 (1608)
R269	1-216-799-91	s RES,	CHIP 15 (1608)
R270	1-216-801-91	s RES,	CHIP 22 (1608)
R272	1-216-833-91	s RES,	CHIP 10K (1608)
R274	1-216-801-91	s RES,	CHIP 22 (1608)
R275	1-216-833-91	s RES,	CHIP 10K (1608)
R276	1-216-817-91	s RES,	CHIP 470 (1608)
R277	1-216-817-91	s RES,	CHIP 470 (1608)
R278	1-216-833-91	s RES,	CHIP 10K (1608)
R279	1-216-833-91	s RES,	CHIP 10K (1608)
R280	1-216-809-91	s RES,	CHIP 100 (1608)

(BC BOARD)

Ref. No. or Q'ty	Part No.	SP Description
R281	1-216-809-91	s RES, CHIP 100 (1608)
R282	1-216-833-91	s RES, CHIP 10K (1608)
R283	1-216-833-91	s RES, CHIP 10K (1608)
R284	1-216-809-91	s RES, CHIP 100 (1608)
R285	1-216-809-91	s RES, CHIP 100 (1608)
R286	1-216-801-91	s RES, CHIP 22 (1608)
R287	1-216-809-91	s RES, CHIP 100 (1608)
R288	1-216-833-91	s RES, CHIP 10K (1608)
R289	1-216-833-91	s RES, CHIP 10K (1608)
R290	1-216-833-91	s RES, CHIP 10K (1608)
R291	1-216-833-91	s RES, CHIP 10K (1608)
R292	1-216-833-91	s RES, CHIP 10K (1608)
R293	1-216-809-91	s RES, CHIP 100 (1608)
R294	1-216-809-91	s RES, CHIP 100 (1608)
R295	1-216-809-91	s RES, CHIP 100 (1608)
R299	1-216-833-91	s RES, CHIP 10K (1608)
R300	1-216-833-91	s RES, CHIP 10K (1608)
R301	1-216-833-91	s RES, CHIP 10K (1608)
R302	1-216-833-91	s RES, CHIP 10K (1608)
R303	1-216-833-91	s RES, CHIP 10K (1608)
R304	1-216-864-91	s CONDUCTOR, CHIP (1608)
R305	1-216-833-91	s RES, CHIP 10K (1608)
R306	1-216-833-91	s RES, CHIP 10K (1608)
R307	1-216-864-91	s CONDUCTOR, CHIP (1608)
R308	1-216-829-91	s RES, CHIP 4.7K (1608)
R309	1-216-833-91	s RES, CHIP 10K (1608)
R311	1-218-847-91	s RES, CHIP 1.0K (1608)
R312	1-218-830-91	s RES, CHIP 200 (1608)
R333	1-216-833-91	s RES, CHIP 10K (1608)
R334	1-216-821-91	s RES, CHIP 1.0K (1608)
R335	1-216-864-91	s CONDUCTOR, CHIP (1608)
R336	1-216-864-91	s CONDUCTOR, CHIP (1608)
R337	1-216-864-91	s CONDUCTOR, CHIP (1608)
R338	1-216-864-91	s CONDUCTOR, CHIP (1608)
R350	1-218-917-91	s RES, CHIP 820K (1608)
R351	1-218-877-91	s RES, CHIP 18K (1608)
R352	1-218-867-91	s RES, CHIP 6.8K (1608)
R353	1-218-901-91	s RES, CHIP 180K (1608)
R354	1-216-837-91	s RES, CHIP 22K (1608)
R355	1-218-873-91	s RES, CHIP 12K (1608)
R356	1-216-833-91	s RES, CHIP 10K (1608)
R357	1-216-833-91	s RES, CHIP 10K (1608)
R358	1-216-833-91	s RES, CHIP 10K (1608)
R360	1-216-821-91	s RES, CHIP 1.0K (1608)
R361	1-218-849-91	s RES, CHIP 1.2K (1608)
R362	1-218-875-91	s RES, CHIP 15K (1608)
R363	1-218-861-91	s RES, CHIP 3.9K (1608)
R364	1-218-875-91	s RES, CHIP 15K (1608)
R365	1-218-863-91	s RES, CHIP 4.7K (1608)
R366	1-216-833-91	s RES, CHIP 10K (1608)
R367	1-216-833-91	s RES, CHIP 10K (1608)
R368	1-216-793-91	s RES, CHIP 4.7 (1608)
R369	1-216-793-91	s RES, CHIP 4.7 (1608)
R370	1-218-863-91	s RES, CHIP 4.7K (1608)
R371	1-216-809-91	s RES, CHIP 100 (1608)
R372	1-219-706-21	s RES, CHIP (SQUARE TYPE) 0.10
R373	1-218-871-91	s RES, CHIP 10K (1608)
R374	1-218-895-91	s RES, CHIP 100K (1608)
R375	1-218-833-91	s RES, CHIP 270 (1608)

(BC BOARD)

Ref. No. or Q'ty	Part No.	SP Description
R376	1-218-865-91	s RES, CHIP 5.6K (1608)
R377	1-216-833-91	s RES, CHIP 10K (1608)
R378	1-216-833-91	s RES, CHIP 10K (1608)
R380	1-216-826-91	s RES, CHIP 2.7K (1608)
R391	1-216-845-91	s RES, CHIP 100K (1608)
R393	1-216-864-91	s CONDUCTOR, CHIP (1608)
R394	1-216-815-91	s RES, CHIP 330 (1608)
R395	1-216-864-91	s CONDUCTOR, CHIP (1608)
R452	1-216-801-91	s RES, CHIP 22 (1608)
R477	1-216-809-91	s RES, CHIP 100 (1608)
R480	1-216-809-91	s RES, CHIP 100 (1608)
R482	1-216-801-91	s RES, CHIP 22 (1608)
R483	1-216-801-91	s RES, CHIP 22 (1608)
R486	1-216-809-91	s RES, CHIP 100 (1608)
R487	1-216-809-91	s RES, CHIP 100 (1608)
R488	1-216-801-91	s RES, CHIP 22 (1608)
R489	1-216-801-91	s RES, CHIP 22 (1608)
R490	1-216-801-91	s RES, CHIP 22 (1608)
R491	1-216-809-91	s RES, CHIP 100 (1608)
R492	1-216-801-91	s RES, CHIP 22 (1608)
R493	1-216-801-91	s RES, CHIP 22 (1608)
R494	1-216-801-91	s RES, CHIP 22 (1608)
R495	1-216-801-91	s RES, CHIP 22 (1608)
R496	1-216-801-91	s RES, CHIP 22 (1608)
R497	1-216-809-91	s RES, CHIP 100 (1608)
R498	1-216-801-91	s RES, CHIP 22 (1608)
R499	1-216-801-91	s RES, CHIP 22 (1608)
R500	1-216-801-91	s RES, CHIP 22 (1608)
R501	1-216-801-91	s RES, CHIP 22 (1608)
R502	1-216-801-91	s RES, CHIP 22 (1608)
R503	1-216-801-91	s RES, CHIP 22 (1608)
R504	1-216-801-91	s RES, CHIP 22 (1608)
R505	1-216-801-91	s RES, CHIP 22 (1608)
R506	1-216-801-91	s RES, CHIP 22 (1608)
R507	1-216-797-91	s RES, CHIP 10 (1608)
R508	1-216-833-91	s RES, CHIP 10K (1608)
R509	1-216-809-91	s RES, CHIP 100 (1608)
R510	1-216-809-91	s RES, CHIP 100 (1608)
R511	1-216-801-91	s RES, CHIP 22 (1608)
R512	1-216-809-91	s RES, CHIP 100 (1608)
R514	1-216-797-91	s RES, CHIP 10 (1608)
R515	1-216-809-91	s RES, CHIP 100 (1608)
R524	1-216-809-91	s RES, CHIP 100 (1608)
R529	1-216-801-91	s RES, CHIP 22 (1608)
R530	1-216-801-91	s RES, CHIP 22 (1608)
R531	1-216-801-91	s RES, CHIP 22 (1608)
R532	1-216-809-91	s RES, CHIP 100 (1608)
R533	1-216-801-91	s RES, CHIP 22 (1608)
R534	1-216-801-91	s RES, CHIP 22 (1608)
R535	1-216-801-91	s RES, CHIP 22 (1608)
R536	1-216-801-91	s RES, CHIP 22 (1608)
R537	1-216-801-91	s RES, CHIP 22 (1608)
R538	1-216-801-91	s RES, CHIP 22 (1608)
R539	1-216-801-91	s RES, CHIP 22 (1608)
R540	1-216-801-91	s RES, CHIP 22 (1608)
R541	1-216-807-91	s RES, CHIP 68 (1608)
R542	1-216-801-91	s RES, CHIP 22 (1608)
R567	1-216-801-91	s RES, CHIP 22 (1608)
R568	1-216-864-91	s CONDUCTOR, CHIP (1608)

(BC BOARD)

Ref. No. or Q'ty	Part No.	SP	Description
R569	1-216-864-91	s	CONDUCTOR, CHIP (1608)
R570	1-216-805-91	s	RES, CHIP 47 (1608)
R571	1-216-805-91	s	RES, CHIP 47 (1608)
R572	1-216-864-91	s	CONDUCTOR, CHIP (1608)
R573	1-216-864-91	s	CONDUCTOR, CHIP (1608)
R575	1-216-809-91	s	RES, CHIP 100 (1608)
R576	1-216-809-91	s	RES, CHIP 100 (1608)
R578	1-218-855-91	s	RES, CHIP 2.2K (1608)
R579	1-216-801-91	s	RES, CHIP 22 (1608)
R580	1-216-801-91	s	RES, CHIP 22 (1608)
R581	1-216-801-91	s	RES, CHIP 22 (1608)
R582	1-216-801-91	s	RES, CHIP 22 (1608)
R591	1-216-801-91	s	RES, CHIP 22 (1608)
R592	1-216-821-91	s	RES, CHIP 1.0K (1608)
R593	1-216-864-91	s	CONDUCTOR, CHIP (1608)
R594	1-216-864-91	s	CONDUCTOR, CHIP (1608)
R595	1-216-821-91	s	RES, CHIP 1.0K (1608)
R596	1-216-812-91	s	RES, CHIP 180 (1608)
R597	1-216-864-91	s	CONDUCTOR, CHIP (1608)
R598	1-216-812-91	s	RES, CHIP 180 (1608)
R599	1-216-864-91	s	CONDUCTOR, CHIP (1608)
R600	1-216-864-91	s	CONDUCTOR, CHIP (1608)
R601	1-216-864-91	s	CONDUCTOR, CHIP (1608)
R602	1-216-864-91	s	CONDUCTOR, CHIP (1608)
R603	1-216-864-91	s	CONDUCTOR, CHIP (1608)
R604	1-216-864-91	s	CONDUCTOR, CHIP (1608)
R605	1-216-809-91	s	RES, CHIP 100 (1608)
R606	1-216-864-91	s	CONDUCTOR, CHIP (1608)
R607	1-216-809-91	s	RES, CHIP 100 (1608)
R608	1-216-812-91	s	RES, CHIP 180 (1608)
RB011	1-234-378-21	s	RES, NETWORK 10K (1005X4)
RB012	1-234-378-21	s	RES, NETWORK 10K (1005X4)
RB013	1-234-378-21	s	RES, NETWORK 10K (1005X4)
RB014	1-234-378-21	s	RES, NETWORK 10K (1005X4)
RB015	1-234-378-21	s	RES, NETWORK 10K (1005X4)
RB016	1-234-377-21	s	RES, NETWORK 4.7K (1005X4)
RB017	1-234-378-21	s	RES, NETWORK 10K (1005X4)
RB018	1-234-377-21	s	RES, NETWORK 4.7K (1005X4)
RB019	1-234-378-21	s	RES, NETWORK 10K (1005X4)
RB020	1-234-377-21	s	RES, NETWORK 4.7K (1005X4)
RB021	1-234-377-21	s	RES, NETWORK 4.7K (1005X4)
RB022	1-234-378-21	s	RES, NETWORK 10K (1005X4)
RB023	1-234-372-21	s	RES, NETWORK 100 (1005X4)
RB024	1-234-372-21	s	RES, NETWORK 100 (1005X4)
RB025	1-234-372-21	s	RES, NETWORK 100 (1005X4)
RB026	1-234-372-21	s	RES, NETWORK 100 (1005X4)
RB027	1-234-372-21	s	RES, NETWORK 100 (1005X4)
RB028	1-234-370-21	s	RES, NETWORK 22 (1005X4)
RB029	1-234-370-21	s	RES, NETWORK 22 (1005X4)
RB030	1-234-370-21	s	RES, NETWORK 22 (1005X4)
RB031	1-234-370-21	s	RES, NETWORK 22 (1005X4)
RB032	1-234-370-21	s	RES, NETWORK 22 (1005X4)
RB033	1-234-370-21	s	RES, NETWORK 22 (1005X4)
RB035	1-234-370-21	s	RES, NETWORK 22 (1005X4)
RB036	1-234-370-21	s	RES, NETWORK 22 (1005X4)
RB037	1-234-369-21	s	RES, NETWORK 10 (1005X4)
RB038	1-234-371-21	s	RES, NETWORK 47 (1005X4)
RB039	1-234-369-21	s	RES, NETWORK 10 (1005X4)
RB040	1-234-371-21	s	RES, NETWORK 47 (1005X4)

(BC BOARD)

Ref. No. or Q'ty	Part No.	SP	Description
RB041	1-234-702-21	s	RES, NETWORK 68 (1005X4)
RB042	1-234-371-21	s	RES, NETWORK 47 (1005X4)
RB043	1-234-370-21	s	RES, NETWORK 22 (1005X4)
RB044	1-234-370-21	s	RES, NETWORK 22 (1005X4)
RB045	1-234-370-21	s	RES, NETWORK 22 (1005X4)
RB046	1-234-370-21	s	RES, NETWORK 22 (1005X4)
RB047	1-234-370-21	s	RES, NETWORK 22 (1005X4)
RB048	1-234-370-21	s	RES, NETWORK 22 (1005X4)
RB049	1-234-370-21	s	RES, NETWORK 22 (1005X4)
RB050	1-234-702-21	s	RES, NETWORK 68 (1005X4)
RB051	1-234-702-21	s	RES, NETWORK 68 (1005X4)
RB052	1-234-371-21	s	RES, NETWORK 47 (1005X4)
RB053	1-234-371-21	s	RES, NETWORK 47 (1005X4)
RB054	1-234-370-21	s	RES, NETWORK 22 (1005X4)
RB055	1-234-370-21	s	RES, NETWORK 22 (1005X4)
RB056	1-234-372-21	s	RES, NETWORK 100 (1005X4)
RB057	1-234-370-21	s	RES, NETWORK 22 (1005X4)
RB058	1-234-370-21	s	RES, NETWORK 22 (1005X4)
RB059	1-234-378-21	s	RES, NETWORK 10K (1005X4)
RB060	1-242-963-21	s	RES, NETWORK 33 (1005X4)
RB061	1-242-963-21	s	RES, NETWORK 33 (1005X4)
RB062	1-242-963-21	s	RES, NETWORK 33 (1005X4)
RB151	1-233-810-21	s	RES, NETWORK 100K (3216)
RB152	1-233-810-21	s	RES, NETWORK 100K (3216)
RB153	1-234-702-21	s	RES, NETWORK 68 (1005X4)
RB154	1-234-702-21	s	RES, NETWORK 68 (1005X4)
RB155	1-234-371-21	s	RES, NETWORK 47 (1005X4)
RB156	1-234-371-21	s	RES, NETWORK 47 (1005X4)
RB157	1-234-371-21	s	RES, NETWORK 47 (1005X4)
RB158	1-234-371-21	s	RES, NETWORK 47 (1005X4)
RB159	1-234-702-21	s	RES, NETWORK 68 (1005X4)
RB160	1-234-371-21	s	RES, NETWORK 47 (1005X4)
RB161	1-234-371-21	s	RES, NETWORK 47 (1005X4)
RB162	1-234-702-21	s	RES, NETWORK 68 (1005X4)
RB163	1-234-702-21	s	RES, NETWORK 68 (1005X4)
RB164	1-234-371-21	s	RES, NETWORK 47 (1005X4)
RB165	1-234-371-21	s	RES, NETWORK 47 (1005X4)
RB166	1-234-377-21	s	RES, NETWORK 4.7K (1005X4)
RB167	1-234-377-21	s	RES, NETWORK 4.7K (1005X4)
RB168	1-234-702-21	s	RES, NETWORK 68 (1005X4)
RB169	1-234-702-21	s	RES, NETWORK 68 (1005X4)
RB170	1-234-702-21	s	RES, NETWORK 68 (1005X4)
RB171	1-234-702-21	s	RES, NETWORK 68 (1005X4)
RB172	1-234-377-21	s	RES, NETWORK 4.7K (1005X4)
RB173	1-234-377-21	s	RES, NETWORK 4.7K (1005X4)
RB174	1-234-377-21	s	RES, NETWORK 4.7K (1005X4)
RB175	1-234-377-21	s	RES, NETWORK 4.7K (1005X4)
RB176	1-234-377-21	s	RES, NETWORK 4.7K (1005X4)
RB177	1-234-377-21	s	RES, NETWORK 4.7K (1005X4)
RB250	1-234-378-21	s	RES, NETWORK 10K (1005X4)
RB251	1-234-370-21	s	RES, NETWORK 22 (1005X4)
RB252	1-234-370-21	s	RES, NETWORK 22 (1005X4)
RB300	1-234-702-21	s	RES, NETWORK 68 (1005X4)
RB301	1-234-702-21	s	RES, NETWORK 68 (1005X4)
RB302	1-234-702-21	s	RES, NETWORK 68 (1005X4)
RB303	1-234-371-21	s	RES, NETWORK 47 (1005X4)
RB304	1-234-371-21	s	RES, NETWORK 47 (1005X4)
RB305	1-234-371-21	s	RES, NETWORK 47 (1005X4)
RB601	1-242-963-21	s	RES, NETWORK 33 (1005X4)

(BC BOARD)

BK BOARD

Ref. No. or Q'ty	Part No.	SP Description
RB605	1-242-963-21	s RES, NETWORK 33 (1005X4)
RB606	1-242-963-21	s RES, NETWORK 33 (1005X4)
RB614	1-242-963-21	s RES, NETWORK 33 (1005X4)
RB615	1-242-963-21	s RES, NETWORK 33 (1005X4)
RB616	1-234-702-21	s RES, NETWORK 68 (1005X4)
RB617	1-234-702-21	s RES, NETWORK 68 (1005X4)
RB618	1-242-963-21	s RES, NETWORK 33 (1005X4)
RB619	1-234-702-21	s RES, NETWORK 68 (1005X4)
RB620	1-234-702-21	s RES, NETWORK 68 (1005X4)
RB621	1-234-702-21	s RES, NETWORK 68 (1005X4)
RB625	1-242-963-21	s RES, NETWORK 33 (1005X4)
RB626	1-242-963-21	s RES, NETWORK 33 (1005X4)
RB627	1-242-963-21	s RES, NETWORK 33 (1005X4)
RB628	1-234-370-21	s RES, NETWORK 22 (1005X4)
RB629	1-234-370-21	s RES, NETWORK 22 (1005X4)
RB630	1-234-370-21	s RES, NETWORK 22 (1005X4)
RB631	1-234-370-21	s RES, NETWORK 22 (1005X4)
RB632	1-234-370-21	s RES, NETWORK 22 (1005X4)
RB633	1-234-370-21	s RES, NETWORK 22 (1005X4)
RB634	1-234-370-21	s RES, NETWORK 22 (1005X4)
RB635	1-234-370-21	s RES, NETWORK 22 (1005X4)
RY301	1-755-145-21	s RELAY
TP001	1-535-877-22	s CHIP, CHECKER
TP007	1-535-877-22	s CHIP, CHECKER
TP008	1-535-877-22	s CHIP, CHECKER
TP011	1-535-877-22	s CHIP, CHECKER
TP150	1-535-877-22	s CHIP, CHECKER
TP151	1-535-877-22	s CHIP, CHECKER
TP152	1-535-877-22	s CHIP, CHECKER
TP250	1-535-877-22	s CHIP, CHECKER
TP251	1-535-877-22	s CHIP, CHECKER
TP300	1-535-877-22	s CHIP, CHECKER
TP302	1-535-877-22	s CHIP, CHECKER
TP306	1-535-877-22	s CHIP, CHECKER
TP307	1-535-877-22	s CHIP, CHECKER
TP308	1-535-877-22	s CHIP, CHECKER
TP309	1-535-877-22	s CHIP, CHECKER
TP350	1-535-877-22	s CHIP, CHECKER
TP351	1-535-877-22	s CHIP, CHECKER
TP352	1-535-877-22	s CHIP, CHECKER
TP353	1-535-877-22	s CHIP, CHECKER
TP354	1-535-877-22	s CHIP, CHECKER
X011	1-813-143-11	s OSCILLATOR, CRYSTAL
X012	1-781-829-22	s OSCILLATOR, CRYSTAL (SMD)
X250	1-795-983-11	s OSCILLATOR, CRYSTAL
X251	1-813-143-11	s OSCILLATOR, CRYSTAL

Ref. No. or Q'ty	Part No.	SP Description
1pc	A-1091-090-A	s MOUNTED CIRCUIT BOARD, BK
5pcs	7-682-647-09	s SCREW +PS 3X6 (SHIELD(5))
C001	1-100-566-91	s CAP, CHIP CERAMIC 0.1MF B 1608
C002	1-100-566-91	s CAP, CHIP CERAMIC 0.1MF B 1608
C003	1-100-566-91	s CAP, CHIP CERAMIC 0.1MF B 1608
C004	1-100-566-91	s CAP, CHIP CERAMIC 0.1MF B 1608
C005	1-100-202-21	s CAP, CHIP ELECT 330MF
C006	1-100-566-91	s CAP, CHIP CERAMIC 0.1MF B 1608
C007	1-115-670-21	s CAP, CHIP TYPE ELECT 220MF
C008	1-100-566-91	s CAP, CHIP CERAMIC 0.1MF B 1608
C009	1-100-566-91	s CAP, CHIP CERAMIC 0.1MF B 1608
C010	1-115-670-21	s CAP, CHIP TYPE ELECT 220MF
C011	1-131-661-21	s CAP, CHIP ELECT 100MF(6.3X5.7)
C012	1-100-202-21	s CAP, CHIP ELECT 330MF
C013	1-100-566-91	s CAP, CHIP CERAMIC 0.1MF B 1608
C014	1-100-566-91	s CAP, CHIP CERAMIC 0.1MF B 1608
C015	1-100-566-91	s CAP, CHIP CERAMIC 0.1MF B 1608
C016	1-100-566-91	s CAP, CHIP CERAMIC 0.1MF B 1608
C017	1-131-661-21	s CAP, CHIP ELECT 100MF(6.3X5.7)
C018	1-100-202-21	s CAP, CHIP ELECT 330MF
C019	1-100-566-91	s CAP, CHIP CERAMIC 0.1MF B 1608
C020	1-100-566-91	s CAP, CHIP CERAMIC 0.1MF B 1608
C021	1-100-566-91	s CAP, CHIP CERAMIC 0.1MF B 1608
C022	1-100-566-91	s CAP, CHIP CERAMIC 0.1MF B 1608
C023	1-131-661-21	s CAP, CHIP ELECT 100MF(6.3X5.7)
C024	1-131-661-21	s CAP, CHIP ELECT 100MF(6.3X5.7)
C025	1-100-566-91	s CAP, CHIP CERAMIC 0.1MF B 1608
C026	1-100-566-91	s CAP, CHIP CERAMIC 0.1MF B 1608
C027	1-100-566-91	s CAP, CHIP CERAMIC 0.1MF B 1608
C028	1-131-661-21	s CAP, CHIP ELECT 100MF(6.3X5.7)
C029	1-100-566-91	s CAP, CHIP CERAMIC 0.1MF B 1608
C030	1-162-927-91	s CAP, CERAMIC 100PF CH 1608
C040	1-126-396-21	s CAP, CHIP ELECT 47MF (6.3X5.7)
C041	1-126-392-21	s CAP, CHIP ELECT 100MF(6.3X5.7)
C042	1-162-970-91	s CAP, CERAMIC 10000PF B 1608
C043	1-126-392-21	s CAP, CHIP ELECT 100MF(6.3X5.7)
C044	1-162-970-91	s CAP, CERAMIC 10000PF B 1608
C045	1-162-970-91	s CAP, CERAMIC 10000PF B 1608
C046	1-126-392-21	s CAP, CHIP ELECT 100MF(6.3X5.7)
C047	1-162-970-91	s CAP, CERAMIC 10000PF B 1608
C048	1-162-970-91	s CAP, CERAMIC 10000PF B 1608
C049	1-100-566-91	s CAP, CHIP CERAMIC 0.1MF B 1608
C050	1-126-392-21	s CAP, CHIP ELECT 100MF(6.3X5.7)
C051	1-100-566-91	s CAP, CHIP CERAMIC 0.1MF B 1608
C052	1-162-970-91	s CAP, CERAMIC 10000PF B 1608
C053	1-162-970-91	s CAP, CERAMIC 10000PF B 1608
C054	1-162-970-91	s CAP, CERAMIC 10000PF B 1608
C055	1-162-970-91	s CAP, CERAMIC 10000PF B 1608
C056	1-162-970-91	s CAP, CERAMIC 10000PF B 1608
C057	1-162-970-91	s CAP, CERAMIC 10000PF B 1608
C058	1-100-566-91	s CAP, CHIP CERAMIC 0.1MF B 1608
C060	1-100-566-91	s CAP, CHIP CERAMIC 0.1MF B 1608
C061	1-162-970-91	s CAP, CERAMIC 10000PF B 1608
C062	1-162-970-91	s CAP, CERAMIC 10000PF B 1608
C063	1-126-392-21	s CAP, CHIP ELECT 100MF(6.3X5.7)
C064	1-162-970-91	s CAP, CERAMIC 10000PF B 1608
C065	1-162-970-91	s CAP, CERAMIC 10000PF B 1608
C066	1-162-970-91	s CAP, CERAMIC 10000PF B 1608
C067	1-162-970-91	s CAP, CERAMIC 10000PF B 1608

(BK BOARD)

Ref. No. or Q'ty	Part No.	SP Description
C354	1-162-970-91	s CAP, CERAMIC 10000PF B 1608
C355	1-100-566-91	s CAP, CHIP CERAMIC 0.1MF B 1608
C356	1-100-756-91	s CAP,CHIPCERAMIC 47000PF B 1608
C357	1-100-566-91	s CAP, CHIP CERAMIC 0.1MF B 1608
C358	1-162-970-91	s CAP, CERAMIC 10000PF B 1608
C359	1-162-970-91	s CAP, CERAMIC 10000PF B 1608
C360	1-100-566-91	s CAP, CHIP CERAMIC 0.1MF B 1608
C361	1-100-566-91	s CAP, CHIP CERAMIC 0.1MF B 1608
C362	1-162-970-91	s CAP, CERAMIC 10000PF B 1608
C363	1-100-566-91	s CAP, CHIP CERAMIC 0.1MF B 1608
C364	1-100-566-91	s CAP, CHIP CERAMIC 0.1MF B 1608
C365	1-100-566-91	s CAP, CHIP CERAMIC 0.1MF B 1608
C366	1-100-566-91	s CAP, CHIP CERAMIC 0.1MF B 1608
C367	1-162-922-91	s CAP, CERAMIC 39PF CH 1608
C368	1-162-922-91	s CAP, CERAMIC 39PF CH 1608
C400	1-162-970-91	s CAP, CERAMIC 10000PF B 1608
C401	1-162-970-91	s CAP, CERAMIC 10000PF B 1608
C402	1-100-566-91	s CAP, CHIP CERAMIC 0.1MF B 1608
C403	1-115-340-91	s CAP, CERAMIC 0.22MF B (2012)
C404	1-100-566-91	s CAP, CHIP CERAMIC 0.1MF B 1608
C405	1-100-566-91	s CAP, CHIP CERAMIC 0.1MF B 1608
C406	1-100-756-91	s CAP,CHIPCERAMIC 47000PF B 1608
C407	1-100-566-91	s CAP, CHIP CERAMIC 0.1MF B 1608
C408	1-162-970-91	s CAP, CERAMIC 10000PF B 1608
C409	1-162-970-91	s CAP, CERAMIC 10000PF B 1608
C410	1-100-566-91	s CAP, CHIP CERAMIC 0.1MF B 1608
C411	1-100-566-91	s CAP, CHIP CERAMIC 0.1MF B 1608
C412	1-162-970-91	s CAP, CERAMIC 10000PF B 1608
C413	1-162-922-91	s CAP, CERAMIC 39PF CH 1608
C414	1-162-922-91	s CAP, CERAMIC 39PF CH 1608
C420	1-100-566-91	s CAP, CHIP CERAMIC 0.1MF B 1608
C421	1-100-566-91	s CAP, CHIP CERAMIC 0.1MF B 1608
C422	1-100-566-91	s CAP, CHIP CERAMIC 0.1MF B 1608
C500	1-100-566-91	s CAP, CHIP CERAMIC 0.1MF B 1608
C501	1-162-970-91	s CAP, CERAMIC 10000PF B 1608
C502	1-100-566-91	s CAP, CHIP CERAMIC 0.1MF B 1608
C503	1-162-970-91	s CAP, CERAMIC 10000PF B 1608
C504	1-100-566-91	s CAP, CHIP CERAMIC 0.1MF B 1608
C505	1-115-340-91	s CAP, CERAMIC 0.22MF B (2012)
C506	1-100-566-91	s CAP, CHIP CERAMIC 0.1MF B 1608
C507	1-100-566-91	s CAP, CHIP CERAMIC 0.1MF B 1608
C508	1-100-756-91	s CAP,CHIPCERAMIC 47000PF B 1608
C509	1-100-566-91	s CAP, CHIP CERAMIC 0.1MF B 1608
C510	1-162-970-91	s CAP, CERAMIC 10000PF B 1608
C511	1-162-970-91	s CAP, CERAMIC 10000PF B 1608
C512	1-126-391-21	s CAP, CHIP ELECT 47MF (5X5.7)
C513	1-100-566-91	s CAP, CHIP CERAMIC 0.1MF B 1608
C514	1-100-566-91	s CAP, CHIP CERAMIC 0.1MF B 1608
C515	1-162-970-91	s CAP, CERAMIC 10000PF B 1608
C516	1-126-391-21	s CAP, CHIP ELECT 47MF (5X5.7)
C517	1-162-922-91	s CAP, CERAMIC 39PF CH 1608
C520	1-100-566-91	s CAP, CHIP CERAMIC 0.1MF B 1608
C521	1-100-566-91	s CAP, CHIP CERAMIC 0.1MF B 1608
C522	1-100-566-91	s CAP, CHIP CERAMIC 0.1MF B 1608
C523	1-100-566-91	s CAP, CHIP CERAMIC 0.1MF B 1608
C524	1-100-566-91	s CAP, CHIP CERAMIC 0.1MF B 1608
C525	1-100-566-91	s CAP, CHIP CERAMIC 0.1MF B 1608
C526	1-100-566-91	s CAP, CHIP CERAMIC 0.1MF B 1608
C527	1-162-970-91	s CAP, CERAMIC 10000PF B 1608

(BK BOARD)

Ref. No. or Q'ty	Part No.	SP Description
5pcs	7-682-647-09	s SCREW +PS 3X6 (SHIELD(5))
C528	1-100-566-91	s CAP, CHIP CERAMIC 0.1MF B 1608
C529	1-100-566-91	s CAP, CHIP CERAMIC 0.1MF B 1608
C530	1-162-970-91	s CAP, CERAMIC 10000PF B 1608
C531	1-100-566-91	s CAP, CHIP CERAMIC 0.1MF B 1608
C532	1-100-566-91	s CAP, CHIP CERAMIC 0.1MF B 1608
C533	1-100-566-91	s CAP, CHIP CERAMIC 0.1MF B 1608
C536	1-100-566-91	s CAP, CHIP CERAMIC 0.1MF B 1608
C537	1-100-566-91	s CAP, CHIP CERAMIC 0.1MF B 1608
C538	1-100-566-91	s CAP, CHIP CERAMIC 0.1MF B 1608
C539	1-100-202-21	s CAP, CHIP ELECT 330MF
C541	1-126-392-21	s CAP, CHIP ELECT 100MF(6.3X5.7)
C543	1-162-918-91	s CAP, CERAMIC 18PF CH 1608
C550	1-162-970-91	s CAP, CERAMIC 10000PF B 1608
C551	1-100-566-91	s CAP, CHIP CERAMIC 0.1MF B 1608
C552	1-115-340-91	s CAP, CERAMIC 0.22MF B (2012)
C553	1-100-566-91	s CAP, CHIP CERAMIC 0.1MF B 1608
C554	1-162-970-91	s CAP, CERAMIC 10000PF B 1608
C555	1-100-566-91	s CAP, CHIP CERAMIC 0.1MF B 1608
C556	1-100-756-91	s CAP,CHIPCERAMIC 47000PF B 1608
C557	1-100-566-91	s CAP, CHIP CERAMIC 0.1MF B 1608
C558	1-162-970-91	s CAP, CERAMIC 10000PF B 1608
C559	1-162-970-91	s CAP, CERAMIC 10000PF B 1608
C560	1-100-566-91	s CAP, CHIP CERAMIC 0.1MF B 1608
C561	1-100-566-91	s CAP, CHIP CERAMIC 0.1MF B 1608
C562	1-162-970-91	s CAP, CERAMIC 10000PF B 1608
C563	1-100-566-91	s CAP, CHIP CERAMIC 0.1MF B 1608
C564	1-100-566-91	s CAP, CHIP CERAMIC 0.1MF B 1608
C565	1-100-566-91	s CAP, CHIP CERAMIC 0.1MF B 1608
C566	1-100-566-91	s CAP, CHIP CERAMIC 0.1MF B 1608
C567	1-162-922-91	s CAP, CERAMIC 39PF CH 1608
C568	1-162-922-91	s CAP, CERAMIC 39PF CH 1608
C600	1-162-966-91	s CAP, CERAMIC 2200PF B 1608
C601	1-100-566-91	s CAP, CHIP CERAMIC 0.1MF B 1608
C602	1-125-827-91	s CAP, CHIP CERAMIC 1MF B
C603	1-100-566-91	s CAP, CHIP CERAMIC 0.1MF B 1608
C604	1-100-566-91	s CAP, CHIP CERAMIC 0.1MF B 1608
C605	1-100-566-91	s CAP, CHIP CERAMIC 0.1MF B 1608
C606	1-125-827-91	s CAP, CHIP CERAMIC 1MF B
C607	1-125-827-91	s CAP, CHIP CERAMIC 1MF B
C608	1-100-566-91	s CAP, CHIP CERAMIC 0.1MF B 1608
C609	1-100-566-91	s CAP, CHIP CERAMIC 0.1MF B 1608
C610	1-125-827-91	s CAP, CHIP CERAMIC 1MF B
C611	1-100-566-91	s CAP, CHIP CERAMIC 0.1MF B 1608
C612	1-125-827-91	s CAP, CHIP CERAMIC 1MF B
C613	1-100-566-91	s CAP, CHIP CERAMIC 0.1MF B 1608
C614	1-100-566-91	s CAP, CHIP CERAMIC 0.1MF B 1608
C615	1-100-566-91	s CAP, CHIP CERAMIC 0.1MF B 1608
C616	1-100-566-91	s CAP, CHIP CERAMIC 0.1MF B 1608
C617	1-100-566-91	s CAP, CHIP CERAMIC 0.1MF B 1608
C618	1-125-827-91	s CAP, CHIP CERAMIC 1MF B
C619	1-125-827-91	s CAP, CHIP CERAMIC 1MF B
C620	1-125-827-91	s CAP, CHIP CERAMIC 1MF B
C650	1-126-396-21	s CAP, CHIP ELECT 47MF (6.3X5.7)
C651	1-162-970-91	s CAP, CERAMIC 10000PF B 1608
C652	1-162-970-91	s CAP, CERAMIC 10000PF B 1608
C653	1-100-566-91	s CAP, CHIP CERAMIC 0.1MF B 1608
C654	1-127-738-91	s CAP, CERAMIC 4700000PF B(3225)
C655	1-100-566-91	s CAP, CHIP CERAMIC 0.1MF B 1608
C656	1-100-566-91	s CAP, CHIP CERAMIC 0.1MF B 1608

(BK BOARD)

Ref. No. or Q'ty	Part No.	SP	Description
C657	1-100-566-91	s	CAP, CHIP CERAMIC 0.1MF B 1608
C658	1-162-970-91	s	CAP, CERAMIC 10000PF B 1608
C700	1-126-392-21	s	CAP, CHIP ELECT 100MF(6.3X5.7)
C701	1-100-566-91	s	CAP, CHIP CERAMIC 0.1MF B 1608
C702	1-162-970-91	s	CAP, CERAMIC 10000PF B 1608
C703	1-162-970-91	s	CAP, CERAMIC 10000PF B 1608
C704	1-162-970-91	s	CAP, CERAMIC 10000PF B 1608
C705	1-100-566-91	s	CAP, CHIP CERAMIC 0.1MF B 1608
C706	1-100-566-91	s	CAP, CHIP CERAMIC 0.1MF B 1608
C707	1-162-970-91	s	CAP, CERAMIC 10000PF B 1608
C708	1-100-566-91	s	CAP, CHIP CERAMIC 0.1MF B 1608
C709	1-162-970-91	s	CAP, CERAMIC 10000PF B 1608
C710	1-126-392-21	s	CAP, CHIP ELECT 100MF(6.3X5.7)
C711	1-162-970-91	s	CAP, CERAMIC 10000PF B 1608
C712	1-162-970-91	s	CAP, CERAMIC 10000PF B 1608
C713	1-162-970-91	s	CAP, CERAMIC 10000PF B 1608
C714	1-162-970-91	s	CAP, CERAMIC 10000PF B 1608
C715	1-162-970-91	s	CAP, CERAMIC 10000PF B 1608
C716	1-162-970-91	s	CAP, CERAMIC 10000PF B 1608
C717	1-162-970-91	s	CAP, CERAMIC 10000PF B 1608
C718	1-162-970-91	s	CAP, CERAMIC 10000PF B 1608
C719	1-162-970-91	s	CAP, CERAMIC 10000PF B 1608
C720	1-162-970-91	s	CAP, CERAMIC 10000PF B 1608
C721	1-162-970-91	s	CAP, CERAMIC 10000PF B 1608
C722	1-162-970-91	s	CAP, CERAMIC 10000PF B 1608
C723	1-100-566-91	s	CAP, CHIP CERAMIC 0.1MF B 1608
C724	1-126-392-21	s	CAP, CHIP ELECT 100MF(6.3X5.7)
C725	1-100-566-91	s	CAP, CHIP CERAMIC 0.1MF B 1608
C726	1-100-566-91	s	CAP, CHIP CERAMIC 0.1MF B 1608
C727	1-100-566-91	s	CAP, CHIP CERAMIC 0.1MF B 1608
C740	1-126-392-21	s	CAP, CHIP ELECT 100MF(6.3X5.7)
C741	1-100-566-91	s	CAP, CHIP CERAMIC 0.1MF B 1608
C742	1-162-970-91	s	CAP, CERAMIC 10000PF B 1608
C743	1-100-566-91	s	CAP, CHIP CERAMIC 0.1MF B 1608
C744	1-162-970-91	s	CAP, CERAMIC 10000PF B 1608
C745	1-126-392-21	s	CAP, CHIP ELECT 100MF(6.3X5.7)
C746	1-100-566-91	s	CAP, CHIP CERAMIC 0.1MF B 1608
C747	1-126-392-21	s	CAP, CHIP ELECT 100MF(6.3X5.7)
C748	1-135-960-91	s	CAP, CHIP CERAMIC 10MF B(3225)
C749	1-162-970-91	s	CAP, CERAMIC 10000PF B 1608
C750	1-100-566-91	s	CAP, CHIP CERAMIC 0.1MF B 1608
C753	1-100-566-91	s	CAP, CHIP CERAMIC 0.1MF B 1608
C754	1-131-661-21	s	CAP, CHIP ELECT 100MF(6.3X5.7)
C755	1-165-908-91	s	CAP, CERAMIC 1000000PF B 1608
C756	1-115-416-91	s	CAP,CHIP CERAMIC1000PF CH 1608
C757	1-131-661-21	s	CAP, CHIP ELECT 100MF(6.3X5.7)
C758	1-115-340-91	s	CAP, CERAMIC 0.22MF B (2012)
C759	1-100-566-91	s	CAP, CHIP CERAMIC 0.1MF B 1608
C761	1-115-340-91	s	CAP, CERAMIC 0.22MF B (2012)
C762	1-115-340-91	s	CAP, CERAMIC 0.22MF B (2012)
C763	1-115-340-91	s	CAP, CERAMIC 0.22MF B (2012)
C764	1-115-340-91	s	CAP, CERAMIC 0.22MF B (2012)
C765	1-115-340-91	s	CAP, CERAMIC 0.22MF B (2012)
C766	1-100-566-91	s	CAP, CHIP CERAMIC 0.1MF B 1608
C767	1-100-566-91	s	CAP, CHIP CERAMIC 0.1MF B 1608
C768	1-100-566-91	s	CAP, CHIP CERAMIC 0.1MF B 1608
C769	1-100-566-91	s	CAP, CHIP CERAMIC 0.1MF B 1608
C770	1-100-566-91	s	CAP, CHIP CERAMIC 0.1MF B 1608
C771	1-100-566-91	s	CAP, CHIP CERAMIC 0.1MF B 1608

(BK BOARD)

Ref. No. or Q'ty	Part No.	SP	Description
C772	1-115-340-91	s	CAP, CERAMIC 0.22MF B (2012)
C773	1-115-340-91	s	CAP, CERAMIC 0.22MF B (2012)
C774	1-115-340-91	s	CAP, CERAMIC 0.22MF B (2012)
C775	1-115-340-91	s	CAP, CERAMIC 0.22MF B (2012)
C776	1-115-340-91	s	CAP, CERAMIC 0.22MF B (2012)
C777	1-115-340-91	s	CAP, CERAMIC 0.22MF B (2012)
C778	1-100-566-91	s	CAP, CHIP CERAMIC 0.1MF B 1608
C779	1-100-566-91	s	CAP, CHIP CERAMIC 0.1MF B 1608
C780	1-100-566-91	s	CAP, CHIP CERAMIC 0.1MF B 1608
C781	1-100-566-91	s	CAP, CHIP CERAMIC 0.1MF B 1608
C782	1-100-566-91	s	CAP, CHIP CERAMIC 0.1MF B 1608
C783	1-100-566-91	s	CAP, CHIP CERAMIC 0.1MF B 1608
C800	1-162-925-91	s	CAP, CERAMIC 68PF CH 1608
C801	1-164-315-91	s	CAP, CERAMIC 470PF CH (1608)
C802	1-162-970-91	s	CAP, CERAMIC 10000PF B 1608
C803	1-162-923-91	s	CAP, CERAMIC 47PF CH 1608
C804	1-100-566-91	s	CAP, CHIP CERAMIC 0.1MF B 1608
C805	1-125-838-91	s	CAP, CHIP CERAMIC2.2MF B(2012)
C806	1-162-970-91	s	CAP, CERAMIC 10000PF B 1608
C807	1-162-966-91	s	CAP, CERAMIC 2200PF B 1608
C808	1-162-966-91	s	CAP, CERAMIC 2200PF B 1608
C809	1-162-925-91	s	CAP, CERAMIC 68PF CH 1608
C810	1-164-315-91	s	CAP, CERAMIC 470PF CH (1608)
C811	1-164-315-91	s	CAP, CERAMIC 470PF CH (1608)
C812	1-162-966-91	s	CAP, CERAMIC 2200PF B 1608
C813	1-162-968-91	s	CAP,CHIP CERAMIC 4700PF B 1608
C814	1-100-566-91	s	CAP, CHIP CERAMIC 0.1MF B 1608
C815	1-100-566-91	s	CAP, CHIP CERAMIC 0.1MF B 1608
C816	1-100-566-91	s	CAP, CHIP CERAMIC 0.1MF B 1608
C817	1-100-566-91	s	CAP, CHIP CERAMIC 0.1MF B 1608
C818	1-127-692-91	s	CAP, CHIP CERAMIC 10MF B 3225
C819	1-162-970-91	s	CAP, CERAMIC 10000PF B 1608
C820	1-127-820-91	s	CAP, CHIP CERAMIC 4.7MF B 3216
C821	1-135-344-21	s	CAP, ELECT 270MF (10X8)
C822	1-135-960-91	s	CAP, CHIP CERAMIC 10MF B(3225)
C823	1-162-970-91	s	CAP, CERAMIC 10000PF B 1608
C824	1-135-960-91	s	CAP, CHIP CERAMIC 10MF B(3225)
C825	1-135-344-21	s	CAP, ELECT 270MF (10X8)
C826	1-165-667-21	s	CAP, ELECT 100MF
C827	1-165-668-21	s	CAP, ELECT 150MF
C829	1-135-344-21	s	CAP, ELECT 270MF (10X8)
C831	1-162-970-91	s	CAP, CERAMIC 10000PF B 1608
C832	1-100-202-21	s	CAP, CHIP ELECT 330MF
C833	1-100-202-21	s	CAP, CHIP ELECT 330MF
C834	1-100-566-91	s	CAP, CHIP CERAMIC 0.1MF B 1608
C835	1-126-401-21	s	CAP, CHIP ELECT 1MF (4X5.7)
C836	1-100-566-91	s	CAP, CHIP CERAMIC 0.1MF B 1608
C837	1-162-970-91	s	CAP, CERAMIC 10000PF B 1608
C838	1-126-392-21	s	CAP, CHIP ELECT 100MF(6.3X5.7)
C839	1-162-970-91	s	CAP, CERAMIC 10000PF B 1608
C840	1-100-566-91	s	CAP, CHIP CERAMIC 0.1MF B 1608
C900	1-162-970-91	s	CAP, CERAMIC 10000PF B 1608
C901	1-100-566-91	s	CAP, CHIP CERAMIC 0.1MF B 1608
C902	1-126-392-21	s	CAP, CHIP ELECT 100MF(6.3X5.7)
C903	1-100-566-91	s	CAP, CHIP CERAMIC 0.1MF B 1608
C904	1-100-566-91	s	CAP, CHIP CERAMIC 0.1MF B 1608
C905	1-100-566-91	s	CAP, CHIP CERAMIC 0.1MF B 1608
C906	1-162-970-91	s	CAP, CERAMIC 10000PF B 1608
C907	1-128-590-21	s	CAP, CHIP ELECT 100MF

(BK BOARD)

Ref. No. or Q'ty	Part No.	SP Description
C908	1-162-970-91	s CAP, CERAMIC 10000PF B 1608
C909	1-100-566-91	s CAP, CHIP CERAMIC 0.1MF B 1608
C910	1-100-566-91	s CAP, CHIP CERAMIC 0.1MF B 1608
C911	1-100-566-91	s CAP, CHIP CERAMIC 0.1MF B 1608
C912	1-100-566-91	s CAP, CHIP CERAMIC 0.1MF B 1608
C913	1-100-566-91	s CAP, CHIP CERAMIC 0.1MF B 1608
C914	1-100-566-91	s CAP, CHIP CERAMIC 0.1MF B 1608
C915	1-162-970-91	s CAP, CERAMIC 10000PF B 1608
C916	1-162-970-91	s CAP, CERAMIC 10000PF B 1608
C917	1-100-566-91	s CAP, CHIP CERAMIC 0.1MF B 1608
C918	1-100-566-91	s CAP, CHIP CERAMIC 0.1MF B 1608
C919	1-100-566-91	s CAP, CHIP CERAMIC 0.1MF B 1608
C920	1-162-970-91	s CAP, CERAMIC 10000PF B 1608
C921	1-100-566-91	s CAP, CHIP CERAMIC 0.1MF B 1608
C922	1-162-970-91	s CAP, CERAMIC 10000PF B 1608
C923	1-162-970-91	s CAP, CERAMIC 10000PF B 1608
C924	1-100-566-91	s CAP, CHIP CERAMIC 0.1MF B 1608
C925	1-100-566-91	s CAP, CHIP CERAMIC 0.1MF B 1608
C926	1-100-566-91	s CAP, CHIP CERAMIC 0.1MF B 1608
C927	1-162-970-91	s CAP, CERAMIC 10000PF B 1608
C928	1-100-566-91	s CAP, CHIP CERAMIC 0.1MF B 1608
C929	1-162-970-91	s CAP, CERAMIC 10000PF B 1608
C930	1-128-590-21	s CAP, CHIP ELECT 100MF
C931	1-100-566-91	s CAP, CHIP CERAMIC 0.1MF B 1608
C932	1-115-340-91	s CAP, CERAMIC 0.22MF B (2012)
C933	1-115-340-91	s CAP, CERAMIC 0.22MF B (2012)
C934	1-115-340-91	s CAP, CERAMIC 0.22MF B (2012)
C935	1-115-340-91	s CAP, CERAMIC 0.22MF B (2012)
C936	1-115-340-91	s CAP, CERAMIC 0.22MF B (2012)
C937	1-115-340-91	s CAP, CERAMIC 0.22MF B (2012)
C940	1-100-566-91	s CAP, CHIP CERAMIC 0.1MF B 1608
C941	1-100-566-91	s CAP, CHIP CERAMIC 0.1MF B 1608
C942	1-100-566-91	s CAP, CHIP CERAMIC 0.1MF B 1608
C943	1-100-566-91	s CAP, CHIP CERAMIC 0.1MF B 1608
C944	1-131-661-21	s CAP, CHIP ELECT 100MF(6.3X5.7)
C945	1-165-908-91	s CAP, CERAMIC 1000000PF B 1608
C946	1-100-566-91	s CAP, CHIP CERAMIC 0.1MF B 1608
C947	1-100-566-91	s CAP, CHIP CERAMIC 0.1MF B 1608
C948	1-100-566-91	s CAP, CHIP CERAMIC 0.1MF B 1608
C949	1-115-416-91	s CAP,CHIP CERAMIC1000PF CH 1608
C950	1-131-661-21	s CAP, CHIP ELECT 100MF(6.3X5.7)
C951	1-115-340-91	s CAP, CERAMIC 0.22MF B (2012)
C952	1-100-566-91	s CAP, CHIP CERAMIC 0.1MF B 1608
C953	1-115-340-91	s CAP, CERAMIC 0.22MF B (2012)
C954	1-115-340-91	s CAP, CERAMIC 0.22MF B (2012)
C955	1-115-340-91	s CAP, CERAMIC 0.22MF B (2012)
C956	1-115-340-91	s CAP, CERAMIC 0.22MF B (2012)
C957	1-115-340-91	s CAP, CERAMIC 0.22MF B (2012)
C959	1-100-566-91	s CAP, CHIP CERAMIC 0.1MF B 1608
C960	1-100-566-91	s CAP, CHIP CERAMIC 0.1MF B 1608
C961	1-100-566-91	s CAP, CHIP CERAMIC 0.1MF B 1608
C962	1-100-566-91	s CAP, CHIP CERAMIC 0.1MF B 1608
C963	1-100-566-91	s CAP, CHIP CERAMIC 0.1MF B 1608
C964	1-100-566-91	s CAP, CHIP CERAMIC 0.1MF B 1608
C967	1-115-340-91	s CAP, CERAMIC 0.22MF B (2012)
C968	1-115-340-91	s CAP, CERAMIC 0.22MF B (2012)
C969	1-100-566-91	s CAP, CHIP CERAMIC 0.1MF B 1608
C970	1-131-661-21	s CAP, CHIP ELECT 100MF(6.3X5.7)
C971	1-165-908-91	s CAP, CERAMIC 1000000PF B 1608

(BK BOARD)

Ref. No. or Q'ty	Part No.	SP Description
C972	1-100-566-91	s CAP, CHIP CERAMIC 0.1MF B 1608
C973	1-115-416-91	s CAP,CHIP CERAMIC1000PF CH 1608
C974	1-131-661-21	s CAP, CHIP ELECT 100MF(6.3X5.7)
C975	1-115-340-91	s CAP, CERAMIC 0.22MF B (2012)
C976	1-100-566-91	s CAP, CHIP CERAMIC 0.1MF B 1608
C977	1-100-566-91	s CAP, CHIP CERAMIC 0.1MF B 1608
C978	1-126-390-21	s CAP, CHIP ELECT 22MF (4X5.7)
C979	1-126-390-21	s CAP, CHIP ELECT 22MF (4X5.7)
C1000	1-162-925-91	s CAP, CERAMIC 68PF CH 1608
C1001	1-164-315-91	s CAP, CERAMIC 470PF CH (1608)
C1002	1-162-970-91	s CAP, CERAMIC 10000PF B 1608
C1003	1-162-923-91	s CAP, CERAMIC 47PF CH 1608
C1004	1-100-566-91	s CAP, CHIP CERAMIC 0.1MF B 1608
C1005	1-125-838-91	s CAP, CHIP CERAMIC2.2MF B(2012)
C1006	1-162-970-91	s CAP, CERAMIC 10000PF B 1608
C1007	1-162-966-91	s CAP, CERAMIC 2200PF B 1608
C1008	1-162-966-91	s CAP, CERAMIC 2200PF B 1608
C1009	1-162-925-91	s CAP, CERAMIC 68PF CH 1608
C1010	1-164-315-91	s CAP, CERAMIC 470PF CH (1608)
C1011	1-164-315-91	s CAP, CERAMIC 470PF CH (1608)
C1012	1-162-966-91	s CAP, CERAMIC 2200PF B 1608
C1013	1-162-968-91	s CAP,CHIP CERAMIC 4700PF B 1608
C1014	1-100-566-91	s CAP, CHIP CERAMIC 0.1MF B 1608
C1015	1-100-566-91	s CAP, CHIP CERAMIC 0.1MF B 1608
C1016	1-100-566-91	s CAP, CHIP CERAMIC 0.1MF B 1608
C1017	1-100-566-91	s CAP, CHIP CERAMIC 0.1MF B 1608
C1018	1-127-692-91	s CAP, CHIP CERAMIC 10MF B 3225
C1019	1-162-970-91	s CAP, CERAMIC 10000PF B 1608
C1020	1-127-820-91	s CAP, CHIP CERAMIC 4.7MF B 3216
C1021	1-135-344-21	s CAP, ELECT 270MF (10X8)
C1022	1-135-960-91	s CAP, CHIP CERAMIC 10MF B(3225)
C1023	1-162-970-91	s CAP, CERAMIC 10000PF B 1608
C1024	1-135-960-91	s CAP, CHIP CERAMIC 10MF B(3225)
C1025	1-135-344-21	s CAP, ELECT 270MF (10X8)
C1026	1-165-667-21	s CAP, ELECT 100MF
C1027	1-165-668-21	s CAP, ELECT 150MF
C1029	1-135-344-21	s CAP, ELECT 270MF (10X8)
C1031	1-162-970-91	s CAP, CERAMIC 10000PF B 1608
C1032	1-100-202-21	s CAP, CHIP ELECT 330MF
C1033	1-100-202-21	s CAP, CHIP ELECT 330MF
C1034	1-100-566-91	s CAP, CHIP CERAMIC 0.1MF B 1608
C1035	1-126-401-21	s CAP, CHIP ELECT 1MF (4X5.7)
C1036	1-100-566-91	s CAP, CHIP CERAMIC 0.1MF B 1608
C1037	1-162-970-91	s CAP, CERAMIC 10000PF B 1608
C1038	1-126-392-21	s CAP, CHIP ELECT 100MF(6.3X5.7)
C1039	1-162-970-91	s CAP, CERAMIC 10000PF B 1608
C1099	1-162-922-91	s CAP, CERAMIC 39PF CH 1608
C1100	1-100-566-91	s CAP, CHIP CERAMIC 0.1MF B 1608
C1101	1-100-566-91	s CAP, CHIP CERAMIC 0.1MF B 1608
C1102	1-126-392-21	s CAP, CHIP ELECT 100MF(6.3X5.7)
C1103	1-100-566-91	s CAP, CHIP CERAMIC 0.1MF B 1608
C1104	1-162-970-91	s CAP, CERAMIC 10000PF B 1608
C1105	1-100-566-91	s CAP, CHIP CERAMIC 0.1MF B 1608
C1106	1-126-392-21	s CAP, CHIP ELECT 100MF(6.3X5.7)
C1107	1-100-756-91	s CAP,CHIPCERAMIC 47000PF B 1608
C1108	1-100-566-91	s CAP, CHIP CERAMIC 0.1MF B 1608
C1109	1-100-566-91	s CAP, CHIP CERAMIC 0.1MF B 1608
C1110	1-100-566-91	s CAP, CHIP CERAMIC 0.1MF B 1608
C1111	1-100-566-91	s CAP, CHIP CERAMIC 0.1MF B 1608

(BK BOARD)

Ref. No. or Q'ty	Part No.	SP Description
C1515	1-100-566-91	s CAP, CHIP CERAMIC 0.1MF B 1608
C1517	1-162-922-91	s CAP, CERAMIC 39PF CH 1608
C1518	1-162-922-91	s CAP, CERAMIC 39PF CH 1608
C1519	1-100-202-21	s CAP, CHIP ELECT 330MF
C1540	1-137-980-91	s CAP,CHIP CERAMIC 0.47MF B 3216
C1541	1-125-827-91	s CAP, CHIP CERAMIC 1MF B
C1542	1-100-566-91	s CAP, CHIP CERAMIC 0.1MF B 1608
C1543	1-100-566-91	s CAP, CHIP CERAMIC 0.1MF B 1608
C1544	1-164-388-91	s CAP, CERAMIC 270PF CH 1608
C1545	1-162-968-91	s CAP,CHIP CERAMIC 4700PF B 1608
C1546	1-125-827-91	s CAP, CHIP CERAMIC 1MF B
C1547	1-100-566-91	s CAP, CHIP CERAMIC 0.1MF B 1608
C1548	1-100-566-91	s CAP, CHIP CERAMIC 0.1MF B 1608
C1570	1-100-566-91	s CAP, CHIP CERAMIC 0.1MF B 1608
C1571	1-100-566-91	s CAP, CHIP CERAMIC 0.1MF B 1608
C1572	1-162-970-91	s CAP, CERAMIC 10000PF B 1608
C1573	1-162-970-91	s CAP, CERAMIC 10000PF B 1608
C1574	1-100-756-91	s CAP,CHIPCERAMIC 47000PF B 1608
C1575	1-100-566-91	s CAP, CHIP CERAMIC 0.1MF B 1608
C1576	1-100-566-91	s CAP, CHIP CERAMIC 0.1MF B 1608
C1577	1-100-566-91	s CAP, CHIP CERAMIC 0.1MF B 1608
C1578	1-125-827-91	s CAP, CHIP CERAMIC 1MF B
C1579	1-100-566-91	s CAP, CHIP CERAMIC 0.1MF B 1608
C1580	1-162-970-91	s CAP, CERAMIC 10000PF B 1608
C1581	1-100-566-91	s CAP, CHIP CERAMIC 0.1MF B 1608
C1582	1-100-566-91	s CAP, CHIP CERAMIC 0.1MF B 1608
C1583	1-162-970-91	s CAP, CERAMIC 10000PF B 1608
C1584	1-100-163-91	s CAP, CHIP CERAM 0.33MF B(2012)
C1585	1-100-566-91	s CAP, CHIP CERAMIC 0.1MF B 1608
C1586	1-100-566-91	s CAP, CHIP CERAMIC 0.1MF B 1608
C1587	1-162-970-91	s CAP, CERAMIC 10000PF B 1608
C1588	1-100-566-91	s CAP, CHIP CERAMIC 0.1MF B 1608
C1589	1-100-566-91	s CAP, CHIP CERAMIC 0.1MF B 1608
C1590	1-162-927-91	s CAP, CERAMIC 100PF CH 1608
C1591	1-162-924-91	s CAP, CERAMIC 56PF CH 1608
C1592	1-162-920-91	s CAP, CERAMIC 27PF CH 1608
C1593	1-100-566-91	s CAP, CHIP CERAMIC 0.1MF B 1608
C1594	1-100-566-91	s CAP, CHIP CERAMIC 0.1MF B 1608
C1595	1-162-970-91	s CAP, CERAMIC 10000PF B 1608
C1596	1-100-756-91	s CAP,CHIPCERAMIC 47000PF B 1608
C1597	1-100-566-91	s CAP, CHIP CERAMIC 0.1MF B 1608
C1598	1-100-566-91	s CAP, CHIP CERAMIC 0.1MF B 1608
C1599	1-100-566-91	s CAP, CHIP CERAMIC 0.1MF B 1608
C1700	1-131-661-21	s CAP, CHIP ELECT 100MF(6.3X5.7)
C1701	1-100-566-91	s CAP, CHIP CERAMIC 0.1MF B 1608
C1702	1-131-661-21	s CAP, CHIP ELECT 100MF(6.3X5.7)
C1703	1-100-566-91	s CAP, CHIP CERAMIC 0.1MF B 1608
C1704	1-162-915-91	s CAP, CERAMIC 10PF CH 1608
C1705	1-162-927-91	s CAP, CERAMIC 100PF CH 1608
C1706	1-100-566-91	s CAP, CHIP CERAMIC 0.1MF B 1608
C1707	1-164-218-91	s CAP,CERAMIC 180PF CH 1608
C1708	1-162-927-91	s CAP, CERAMIC 100PF CH 1608
C1709	1-100-566-91	s CAP, CHIP CERAMIC 0.1MF B 1608
C1710	1-100-566-91	s CAP, CHIP CERAMIC 0.1MF B 1608
C1711	1-100-566-91	s CAP, CHIP CERAMIC 0.1MF B 1608
C1712	1-100-566-91	s CAP, CHIP CERAMIC 0.1MF B 1608
C1713	1-162-919-91	s CAP, CERAMIC 22PF CH 1608
C1714	1-100-566-91	s CAP, CHIP CERAMIC 0.1MF B 1608
C1715	1-100-566-91	s CAP, CHIP CERAMIC 0.1MF B 1608

(BK BOARD)

Ref. No. or Q'ty	Part No.	SP Description
C1716	1-100-566-91	s CAP, CHIP CERAMIC 0.1MF B 1608
C1717	1-100-566-91	s CAP, CHIP CERAMIC 0.1MF B 1608
C1718	1-100-566-91	s CAP, CHIP CERAMIC 0.1MF B 1608
C1719	1-100-566-91	s CAP, CHIP CERAMIC 0.1MF B 1608
C1720	1-100-566-91	s CAP, CHIP CERAMIC 0.1MF B 1608
C1721	1-100-566-91	s CAP, CHIP CERAMIC 0.1MF B 1608
C1900	1-100-566-91	s CAP, CHIP CERAMIC 0.1MF B 1608
C1901	1-131-661-21	s CAP, CHIP ELECT 100MF(6.3X5.7)
C1902	1-100-566-91	s CAP, CHIP CERAMIC 0.1MF B 1608
C1903	1-131-661-21	s CAP, CHIP ELECT 100MF(6.3X5.7)
C1904	1-100-566-91	s CAP, CHIP CERAMIC 0.1MF B 1608
C1905	1-100-566-91	s CAP, CHIP CERAMIC 0.1MF B 1608
C1906	1-100-566-91	s CAP, CHIP CERAMIC 0.1MF B 1608
C1907	1-100-566-91	s CAP, CHIP CERAMIC 0.1MF B 1608
C1908	1-100-566-91	s CAP, CHIP CERAMIC 0.1MF B 1608
C1909	1-126-391-21	s CAP, CHIP ELECT 47MF (5X5.7)
C1910	1-126-391-21	s CAP, CHIP ELECT 47MF (5X5.7)
C1911	1-162-927-91	s CAP, CERAMIC 100PF CH 1608
C1912	1-162-927-91	s CAP, CERAMIC 100PF CH 1608
C1913	1-162-927-91	s CAP, CERAMIC 100PF CH 1608
C1914	1-100-566-91	s CAP, CHIP CERAMIC 0.1MF B 1608
C1915	1-100-566-91	s CAP, CHIP CERAMIC 0.1MF B 1608
C1916	1-100-566-91	s CAP, CHIP CERAMIC 0.1MF B 1608
C1917	1-164-218-91	s CAP,CERAMIC 180PF CH 1608
C1918	1-164-218-91	s CAP,CERAMIC 180PF CH 1608
C1919	1-164-218-91	s CAP,CERAMIC 180PF CH 1608
C1920	1-162-927-91	s CAP, CERAMIC 100PF CH 1608
C1921	1-162-927-91	s CAP, CERAMIC 100PF CH 1608
C1922	1-162-927-91	s CAP, CERAMIC 100PF CH 1608
C1923	1-100-566-91	s CAP, CHIP CERAMIC 0.1MF B 1608
C1924	1-100-566-91	s CAP, CHIP CERAMIC 0.1MF B 1608
C1925	1-100-566-91	s CAP, CHIP CERAMIC 0.1MF B 1608
C1926	1-100-566-91	s CAP, CHIP CERAMIC 0.1MF B 1608
C1927	1-100-566-91	s CAP, CHIP CERAMIC 0.1MF B 1608
C1928	1-100-566-91	s CAP, CHIP CERAMIC 0.1MF B 1608
C1929	1-100-566-91	s CAP, CHIP CERAMIC 0.1MF B 1608
C1930	1-100-566-91	s CAP, CHIP CERAMIC 0.1MF B 1608
C1931	1-100-566-91	s CAP, CHIP CERAMIC 0.1MF B 1608
C1932	1-100-566-91	s CAP, CHIP CERAMIC 0.1MF B 1608
C1933	1-100-566-91	s CAP, CHIP CERAMIC 0.1MF B 1608
C1934	1-100-566-91	s CAP, CHIP CERAMIC 0.1MF B 1608
C1935	1-100-566-91	s CAP, CHIP CERAMIC 0.1MF B 1608
C1936	1-100-566-91	s CAP, CHIP CERAMIC 0.1MF B 1608
C1937	1-100-566-91	s CAP, CHIP CERAMIC 0.1MF B 1608
C1938	1-162-970-91	s CAP, CERAMIC 10000PF B 1608
C1939	1-162-970-91	s CAP, CERAMIC 10000PF B 1608
C1940	1-162-970-91	s CAP, CERAMIC 10000PF B 1608
C1941	1-100-756-91	s CAP,CHIPCERAMIC 47000PF B 1608
C1942	1-100-756-91	s CAP,CHIPCERAMIC 47000PF B 1608
C1943	1-100-756-91	s CAP,CHIPCERAMIC 47000PF B 1608
C1944	1-100-566-91	s CAP, CHIP CERAMIC 0.1MF B 1608
C1945	1-100-566-91	s CAP, CHIP CERAMIC 0.1MF B 1608
C1946	1-100-566-91	s CAP, CHIP CERAMIC 0.1MF B 1608
C1947	1-100-566-91	s CAP, CHIP CERAMIC 0.1MF B 1608
CN001	1-817-753-11	o CONNECTOR, BOARD TO BOARD 100P
CN002	1-817-753-11	o CONNECTOR, BOARD TO BOARD 100P
CN040	1-764-080-21	o PIN, CONNECTOR (PC BOARD) 8P
D040	8-719-064-52	s DIODE CL-191YG-CD-T

(BK BOARD)

Ref. No. or Q'ty	Part No.	SP	Description
D151	8-719-404-50	s	DIODE MA111-TX
D152	8-719-404-50	s	DIODE MA111-TX
D351	8-719-404-50	s	DIODE MA111-TX
D352	8-719-404-50	s	DIODE MA111-TX
D551	8-719-404-50	s	DIODE MA111-TX
D552	8-719-404-50	s	DIODE MA111-TX
D600	8-719-404-50	s	DIODE MA111-TX
D601	8-719-404-50	s	DIODE MA111-TX
D602	8-719-404-50	s	DIODE MA111-TX
D604	8-719-404-50	s	DIODE MA111-TX
D700	8-719-064-52	s	DIODE CL-191YG-CD-T
D740	8-719-404-50	s	DIODE MA111-TX
D800	8-719-027-76	s	DIODE 1SS357-TPH3
D801	8-719-027-76	s	DIODE 1SS357-TPH3
D802	8-719-073-92	s	DIODE RB060L-40TE25
D803	8-719-073-92	s	DIODE RB060L-40TE25
D804	8-719-404-50	s	DIODE MA111-TX
D805	8-719-404-50	s	DIODE MA111-TX
D900	8-719-064-52	s	DIODE CL-191YG-CD-T
D1000	8-719-027-76	s	DIODE 1SS357-TPH3
D1001	8-719-027-76	s	DIODE 1SS357-TPH3
D1002	8-719-073-92	s	DIODE RB060L-40TE25
D1003	8-719-073-92	s	DIODE RB060L-40TE25
D1004	8-719-404-50	s	DIODE MA111-TX
D1005	8-719-404-50	s	DIODE MA111-TX
D1140	8-719-404-50	s	DIODE MA111-TX
D1340	8-719-404-50	s	DIODE MA111-TX
D1540	8-719-404-50	s	DIODE MA111-TX
F800	1-576-328-21	s	FUSE (SMD) (8A/125V)
F801	1-576-328-21	s	FUSE (SMD) (8A/125V)
F802	1-533-999-21	s	FUSE, (SMD) (2A/125V)
F1000	1-576-328-21	s	FUSE (SMD) (8A/125V)
F1001	1-576-328-21	s	FUSE (SMD) (8A/125V)
F1002	1-533-999-21	s	FUSE, (SMD) (2A/125V)
IC001	8-759-573-91	s	IC AD8055ARTZ-REEL7
IC002	6-705-469-01	s	IC BA50BC0FP-E2
IC003	8-759-539-89	s	IC LM2990SX-5.0
IC004	6-705-469-01	s	IC BA50BC0FP-E2
IC005	8-759-539-89	s	IC LM2990SX-5.0
IC006	6-705-469-01	s	IC BA50BC0FP-E2
IC007	8-759-539-89	s	IC LM2990SX-5.0
IC008	6-705-469-01	s	IC BA50BC0FP-E2
IC009	8-759-539-89	s	IC LM2990SX-5.0
IC040	6-705-468-01	s	IC BA33BC0FP-E2
IC041	8-759-679-54	s	IC SN74LVC14APWR
IC042	6-709-436-01	s	IC LC4128V-5TN100CA1353
IC043	6-705-027-01	s	IC BD4840FVE-TR
IC044	8-759-592-46	s	IC TC7SZ05FU (TE85R)
IC045	8-759-679-54	s	IC SN74LVC14APWR
IC046	8-759-679-54	s	IC SN74LVC14APWR
IC047	8-759-573-97	s	IC SN74LVC541APWR
IC048	8-759-679-54	s	IC SN74LVC14APWR
IC049	8-759-592-49	s	IC TC7SZ125FU (TE85R)
IC050	6-706-489-01	s	IC TC7SH32FU (T5RSOYJF)
IC051	6-708-748-01	s	IC BD4828FVE-TR
IC100	8-759-573-91	s	IC AD8055ARTZ-REEL7
IC101	8-759-523-02	s	IC TC74HC4053AFT (EL)
IC102	8-759-669-73	s	IC TL082CPWR

(BK BOARD)

Ref. No. or Q'ty	Part No.	SP	Description
IC103	6-705-028-01	s	IC LMH6502MAX
IC120	8-759-573-91	s	IC AD8055ARTZ-REEL7
IC121	8-759-573-91	s	IC AD8055ARTZ-REEL7
IC122	8-759-523-02	s	IC TC74HC4053AFT (EL)
IC123	8-759-669-73	s	IC TL082CPWR
IC124	8-759-573-91	s	IC AD8055ARTZ-REEL7
IC125	6-707-129-01	s	IC AD8184ARZ-REEL7
IC150	8-759-669-73	s	IC TL082CPWR
IC151	6-705-028-01	s	IC LMH6502MAX
IC152	8-759-523-02	s	IC TC74HC4053AFT (EL)
IC153	6-707-129-01	s	IC AD8184ARZ-REEL7
IC200	8-759-523-02	s	IC TC74HC4053AFT (EL)
IC201	8-759-669-73	s	IC TL082CPWR
IC202	6-705-028-01	s	IC LMH6502MAX
IC220	8-759-573-91	s	IC AD8055ARTZ-REEL7
IC300	8-759-573-91	s	IC AD8055ARTZ-REEL7
IC301	8-759-523-02	s	IC TC74HC4053AFT (EL)
IC302	8-759-669-73	s	IC TL082CPWR
IC303	6-705-028-01	s	IC LMH6502MAX
IC320	8-759-573-91	s	IC AD8055ARTZ-REEL7
IC321	8-759-573-91	s	IC AD8055ARTZ-REEL7
IC322	8-759-523-02	s	IC TC74HC4053AFT (EL)
IC323	8-759-669-73	s	IC TL082CPWR
IC324	8-759-573-91	s	IC AD8055ARTZ-REEL7
IC325	6-707-129-01	s	IC AD8184ARZ-REEL7
IC350	8-759-669-73	s	IC TL082CPWR
IC351	6-705-028-01	s	IC LMH6502MAX
IC352	8-759-523-02	s	IC TC74HC4053AFT (EL)
IC353	6-707-129-01	s	IC AD8184ARZ-REEL7
IC400	8-759-523-02	s	IC TC74HC4053AFT (EL)
IC401	8-759-669-73	s	IC TL082CPWR
IC402	6-705-028-01	s	IC LMH6502MAX
IC420	8-759-564-49	s	IC TC7W53FU (TE12R)
IC421	8-759-645-76	s	IC TC74VHCT32AFT
IC500	8-759-573-91	s	IC AD8055ARTZ-REEL7
IC501	8-759-523-02	s	IC TC74HC4053AFT (EL)
IC502	8-759-669-73	s	IC TL082CPWR
IC503	6-705-028-01	s	IC LMH6502MAX
IC520	8-759-573-91	s	IC AD8055ARTZ-REEL7
IC521	8-759-573-91	s	IC AD8055ARTZ-REEL7
IC522	8-759-573-91	s	IC AD8055ARTZ-REEL7
IC523	8-759-523-02	s	IC TC74HC4053AFT (EL)
IC524	8-759-669-73	s	IC TL082CPWR
IC525	8-759-573-91	s	IC AD8055ARTZ-REEL7
IC527	6-707-129-01	s	IC AD8184ARZ-REEL7
IC550	8-759-669-73	s	IC TL082CPWR
IC551	6-705-028-01	s	IC LMH6502MAX
IC552	8-759-523-02	s	IC TC74HC4053AFT (EL)
IC553	6-707-129-01	s	IC AD8184ARZ-REEL7
IC600	8-759-669-73	s	IC TL082CPWR
IC601	8-759-669-73	s	IC TL082CPWR
IC602	8-759-564-49	s	IC TC7W53FU (TE12R)
IC603	8-759-276-28	s	IC LM393PS-E20
IC605	8-759-573-91	s	IC AD8055ARTZ-REEL7
IC650	8-759-276-28	s	IC LM393PS-E20
IC653	8-759-523-02	s	IC TC74HC4053AFT (EL)
IC654	8-759-669-73	s	IC TL082CPWR
IC700	8-759-523-84	s	IC TC74VHCT14FT (EL)
IC701	8-759-491-46	s	IC TC74VHCT04AFT (EL)

(BK BOARD)

Ref. No. or Q'ty	Part No.	SP	Description
IC704	8-759-523-84	s	IC TC74VHC14FT(EL)
IC705	8-759-491-46	s	IC TC74VHC04AFT(EL)
IC740	6-704-006-01	s	IC BR24L64F-WE2
IC742	6-700-394-01	s	IC BA25BC0FP-E2
IC750	8-759-669-78	s	IC TLC2933IPWR-12
IC760	8-759-669-73	s	IC TL082CPWR
IC761	8-759-669-73	s	IC TL082CPWR
IC762	8-759-669-73	s	IC TL082CPWR
IC763	8-759-669-73	s	IC TL082CPWR
IC764	8-759-669-73	s	IC TL082CPWR
IC765	8-759-669-73	s	IC TL082CPWR
IC800	6-702-510-01	s	IC TPS5120DBTRG4
IC900	8-759-523-84	s	IC TC74VHC14FT(EL)
IC903	8-759-523-80	s	IC TC74VHC04FT(EL)
IC904	8-759-523-84	s	IC TC74VHC14FT(EL)
IC905	8-759-490-41	s	IC TC74VHCT541AFT(EL)
IC906	8-759-490-41	s	IC TC74VHCT541AFT(EL)
IC907	6-700-387-01	s	IC EPC2LC20N-TP
IC930	8-759-491-46	s	IC TC74VHCT04AFT(EL)
IC931	8-759-669-73	s	IC TL082CPWR
IC932	8-759-669-73	s	IC TL082CPWR
IC933	8-759-669-73	s	IC TL082CPWR
IC934	8-759-669-78	s	IC TLC2933IPWR-12
IC935	8-759-669-73	s	IC TL082CPWR
IC936	8-759-669-73	s	IC TL082CPWR
IC937	8-759-669-73	s	IC TL082CPWR
IC938	8-759-669-75	s	IC TLC2932IPWRG4
IC939	8-759-669-73	s	IC TL082CPWR
IC1000	6-702-510-01	s	IC TPS5120DBTRG4
IC1100	6-707-130-01	s	IC LMH6503MAX/NOPB
IC1101	6-705-028-01	s	IC LMH6502MAX
IC1102	8-759-523-02	s	IC TC74HC4053AFT(EL)
IC1103	8-759-573-91	s	IC AD8055ARTZ-REEL7
IC1140	8-759-669-73	s	IC TL082CPWR
IC1141	8-759-669-73	s	IC TL082CPWR
IC1170	8-759-523-02	s	IC TC74HC4053AFT(EL)
IC1171	8-759-276-28	s	IC LM393PS-E20
IC1174	8-759-669-73	s	IC TL082CPWR
IC1175	8-759-523-02	s	IC TC74HC4053AFT(EL)
IC1176	8-759-669-73	s	IC TL082CPWR
IC1177	8-759-573-91	s	IC AD8055ARTZ-REEL7
IC1178	8-759-564-49	s	IC TC7W53FU(TE12R)
IC1179	8-759-669-73	s	IC TL082CPWR
IC1300	6-707-130-01	s	IC LMH6503MAX/NOPB
IC1301	6-705-028-01	s	IC LMH6502MAX
IC1302	8-759-523-02	s	IC TC74HC4053AFT(EL)
IC1303	8-759-573-91	s	IC AD8055ARTZ-REEL7
IC1340	8-759-669-73	s	IC TL082CPWR
IC1341	8-759-669-73	s	IC TL082CPWR
IC1370	8-759-523-02	s	IC TC74HC4053AFT(EL)
IC1371	8-759-276-28	s	IC LM393PS-E20
IC1374	8-759-669-73	s	IC TL082CPWR
IC1375	8-759-523-02	s	IC TC74HC4053AFT(EL)
IC1376	8-759-669-73	s	IC TL082CPWR
IC1377	8-759-573-91	s	IC AD8055ARTZ-REEL7
IC1378	8-759-564-49	s	IC TC7W53FU(TE12R)
IC1379	8-759-669-73	s	IC TL082CPWR
IC1500	6-707-130-01	s	IC LMH6503MAX/NOPB
IC1501	6-705-028-01	s	IC LMH6502MAX

(BK BOARD)

Ref. No. or Q'ty	Part No.	SP	Description
IC1502	8-759-523-02	s	IC TC74HC4053AFT(EL)
IC1503	8-759-573-91	s	IC AD8055ARTZ-REEL7
IC1540	8-759-669-73	s	IC TL082CPWR
IC1541	8-759-669-73	s	IC TL082CPWR
IC1570	8-759-523-02	s	IC TC74HC4053AFT(EL)
IC1571	8-759-276-28	s	IC LM393PS-E20
IC1574	8-759-669-73	s	IC TL082CPWR
IC1575	8-759-523-02	s	IC TC74HC4053AFT(EL)
IC1576	8-759-669-73	s	IC TL082CPWR
IC1577	8-759-573-91	s	IC AD8055ARTZ-REEL7
IC1578	8-759-564-49	s	IC TC7W53FU(TE12R)
IC1579	8-759-669-73	s	IC TL082CPWR
IC1700	8-759-564-49	s	IC TC7W53FU(TE12R)
IC1701	8-752-371-56	s	IC CXD1171M-TH
IC1900	8-752-414-92	s	IC CXD2309AQ-T6
IC1901	8-759-669-73	s	IC TL082CPWR
IC1902	8-759-669-73	s	IC TL082CPWR
IC1903	8-759-669-73	s	IC TL082CPWR
IC1904	8-759-523-02	s	IC TC74HC4053AFT(EL)
L040	1-412-955-21	s	INDUCTOR, SMALL TYPE 22UH 2520
L740	1-416-345-21	s	COIL, CHOKE 22UH
L750	1-412-029-22	s	CHIP INDUCTOR 10UH
L800	1-469-848-21	s	INDUCTOR (SMD)
L801	1-469-848-21	s	INDUCTOR (SMD)
L802	1-469-848-21	s	INDUCTOR (SMD)
L803	1-469-848-21	s	INDUCTOR (SMD)
L804	1-469-848-21	s	INDUCTOR (SMD)
L931	1-412-029-22	s	CHIP INDUCTOR 10UH
L932	1-412-029-22	s	CHIP INDUCTOR 10UH
L1000	1-469-848-21	s	INDUCTOR (SMD)
L1001	1-469-848-21	s	INDUCTOR (SMD)
L1002	1-469-848-21	s	INDUCTOR (SMD)
L1003	1-469-848-21	s	INDUCTOR (SMD)
L1004	1-469-848-21	s	INDUCTOR (SMD)
L1700	1-412-029-22	s	CHIP INDUCTOR 10UH
L1900	1-412-029-22	s	CHIP INDUCTOR 10UH
Q040	8-729-029-14	s	TRANSISTOR DTC144EUA-T106
Q041	8-729-028-73	s	TRANSISTOR DTA114EUA-T106
Q042	8-729-028-81	s	TRANSISTOR DTA123JUA-T106
Q043	8-729-029-04	s	TRANSISTOR DTC123JUA-T106
Q044	8-729-029-04	s	TRANSISTOR DTC123JUA-T106
Q150	8-729-026-53	s	TRANSISTOR 2SA1576A-T106-QR
Q151	8-729-028-91	s	TRANSISTOR DTA144EUA-T106
Q152	8-729-905-38	s	TRANSISTOR 2SC4081T106R
Q153	8-729-140-86	s	TRANSISTOR 2SA1610-T1Y34
Q153	8-729-143-09	s	TRANSISTOR 2SA1610-T1Y33
Q154	8-729-026-53	s	TRANSISTOR 2SA1576A-T106-QR
Q155	8-729-905-38	s	TRANSISTOR 2SC4081T106R
Q350	8-729-026-53	s	TRANSISTOR 2SA1576A-T106-QR
Q351	8-729-028-91	s	TRANSISTOR DTA144EUA-T106
Q352	8-729-905-38	s	TRANSISTOR 2SC4081T106R
Q353	8-729-140-86	s	TRANSISTOR 2SA1610-T1Y34
Q353	8-729-143-09	s	TRANSISTOR 2SA1610-T1Y33
Q354	8-729-026-53	s	TRANSISTOR 2SA1576A-T106-QR
Q550	8-729-026-53	s	TRANSISTOR 2SA1576A-T106-QR
Q551	8-729-028-91	s	TRANSISTOR DTA144EUA-T106
Q552	8-729-905-38	s	TRANSISTOR 2SC4081T106R
Q553	8-729-140-86	s	TRANSISTOR 2SA1610-T1Y34

(BK BOARD)

Ref. No. or Q'ty	Part No.	SP	Description
Q553	8-729-143-09	s	TRANSISTOR 2SA1610-T1Y33
Q554	8-729-026-53	s	TRANSISTOR 2SA1576A-T106-QR
Q650	8-729-026-53	s	TRANSISTOR 2SA1576A-T106-QR
Q651	8-729-026-53	s	TRANSISTOR 2SA1576A-T106-QR
Q652	8-729-026-53	s	TRANSISTOR 2SA1576A-T106-QR
Q653	8-729-905-38	s	TRANSISTOR 2SC4081T106R
Q700	8-729-029-04	s	TRANSISTOR DTC123JUA-T106
Q740	8-729-029-04	s	TRANSISTOR DTC123JUA-T106
Q750	8-729-028-91	s	TRANSISTOR DTA144EUA-T106
Q751	8-729-029-04	s	TRANSISTOR DTC123JUA-T106
Q801	6-550-374-01	s	TRANSISTOR TPC8009-H (T2LSONYF
Q803	6-550-374-01	s	TRANSISTOR TPC8009-H (T2LSONYF
Q804	6-550-374-01	s	TRANSISTOR TPC8009-H (T2LSONYF
Q807	6-550-374-01	s	TRANSISTOR TPC8009-H (T2LSONYF
Q808	8-729-026-53	s	TRANSISTOR 2SA1576A-T106-QR
Q809	8-729-029-04	s	TRANSISTOR DTC123JUA-T106
Q810	8-729-028-81	s	TRANSISTOR DTA123JUA-T106
Q811	8-729-029-04	s	TRANSISTOR DTC123JUA-T106
Q812	8-729-028-81	s	TRANSISTOR DTA123JUA-T106
Q900	8-729-029-04	s	TRANSISTOR DTC123JUA-T106
Q901	8-729-029-04	s	TRANSISTOR DTC123JUA-T106
Q931	8-729-028-91	s	TRANSISTOR DTA144EUA-T106
Q932	8-729-029-04	s	TRANSISTOR DTC123JUA-T106
Q933	8-729-029-04	s	TRANSISTOR DTC123JUA-T106
Q934	8-729-028-91	s	TRANSISTOR DTA144EUA-T106
Q935	8-729-029-04	s	TRANSISTOR DTC123JUA-T106
Q1001	6-550-374-01	s	TRANSISTOR TPC8009-H (T2LSONYF
Q1003	6-550-374-01	s	TRANSISTOR TPC8009-H (T2LSONYF
Q1004	6-550-374-01	s	TRANSISTOR TPC8009-H (T2LSONYF
Q1007	6-550-374-01	s	TRANSISTOR TPC8009-H (T2LSONYF
Q1008	8-729-026-53	s	TRANSISTOR 2SA1576A-T106-QR
Q1009	8-729-029-04	s	TRANSISTOR DTC123JUA-T106
Q1010	8-729-028-81	s	TRANSISTOR DTA123JUA-T106
Q1011	8-729-028-81	s	TRANSISTOR DTA123JUA-T106
Q1012	8-729-029-04	s	TRANSISTOR DTC123JUA-T106
Q1100	8-729-029-04	s	TRANSISTOR DTC123JUA-T106
Q1101	8-729-140-86	s	TRANSISTOR 2SA1610-T1Y34
Q1101	8-729-143-09	s	TRANSISTOR 2SA1610-T1Y33
Q1102	8-729-144-81	s	TRANSISTOR 2SC4176T1B33B34B35
Q1140	8-729-905-38	s	TRANSISTOR 2SC4081T106R
Q1141	8-729-026-53	s	TRANSISTOR 2SA1576A-T106-QR
Q1300	8-729-029-04	s	TRANSISTOR DTC123JUA-T106
Q1301	8-729-140-86	s	TRANSISTOR 2SA1610-T1Y34
Q1301	8-729-143-09	s	TRANSISTOR 2SA1610-T1Y33
Q1302	8-729-144-81	s	TRANSISTOR 2SC4176T1B33B34B35
Q1340	8-729-905-38	s	TRANSISTOR 2SC4081T106R
Q1341	8-729-026-53	s	TRANSISTOR 2SA1576A-T106-QR
Q1500	8-729-029-04	s	TRANSISTOR DTC123JUA-T106
Q1501	8-729-140-86	s	TRANSISTOR 2SA1610-T1Y34
Q1501	8-729-143-09	s	TRANSISTOR 2SA1610-T1Y33
Q1502	8-729-144-81	s	TRANSISTOR 2SC4176T1B33B34B35
Q1540	8-729-905-38	s	TRANSISTOR 2SC4081T106R
Q1541	8-729-026-53	s	TRANSISTOR 2SA1576A-T106-QR
Q1700	8-729-026-53	s	TRANSISTOR 2SA1576A-T106-QR
Q1701	8-729-905-38	s	TRANSISTOR 2SC4081T106R
Q1702	8-729-026-53	s	TRANSISTOR 2SA1576A-T106-QR
Q1703	8-729-026-53	s	TRANSISTOR 2SA1576A-T106-QR
Q1704	8-729-905-38	s	TRANSISTOR 2SC4081T106R
Q1705	8-729-026-53	s	TRANSISTOR 2SA1576A-T106-QR

(BK BOARD)

Ref. No. or Q'ty	Part No.	SP	Description
Q1706	8-729-905-38	s	TRANSISTOR 2SC4081T106R
Q1900	8-729-026-53	s	TRANSISTOR 2SA1576A-T106-QR
Q1901	8-729-026-53	s	TRANSISTOR 2SA1576A-T106-QR
Q1902	8-729-026-53	s	TRANSISTOR 2SA1576A-T106-QR
Q1903	8-729-026-53	s	TRANSISTOR 2SA1576A-T106-QR
Q1904	8-729-026-53	s	TRANSISTOR 2SA1576A-T106-QR
Q1905	8-729-026-53	s	TRANSISTOR 2SA1576A-T106-QR
Q1906	8-729-026-53	s	TRANSISTOR 2SA1576A-T106-QR
Q1907	8-729-026-53	s	TRANSISTOR 2SA1576A-T106-QR
Q1908	8-729-026-53	s	TRANSISTOR 2SA1576A-T106-QR
Q1909	8-729-905-38	s	TRANSISTOR 2SC4081T106R
Q1910	8-729-905-38	s	TRANSISTOR 2SC4081T106R
Q1911	8-729-905-38	s	TRANSISTOR 2SC4081T106R
Q1912	8-729-905-38	s	TRANSISTOR 2SC4081T106R
Q1913	8-729-905-38	s	TRANSISTOR 2SC4081T106R
Q1914	8-729-905-38	s	TRANSISTOR 2SC4081T106R
R001	1-218-867-91	s	RES, CHIP 6.8K (1608)
R002	1-218-859-91	s	RES, CHIP 3.3K (1608)
R003	1-216-809-91	s	RES, CHIP 100 (1608)
R004	1-218-847-91	s	RES, CHIP 1.0K (1608)
R007	1-218-847-91	s	RES, CHIP 1.0K (1608)
R040	1-216-821-91	s	RES, CHIP 1.0K (1608)
R041	1-216-841-91	s	RES, CHIP 47K (1608)
R042	1-216-841-91	s	RES, CHIP 47K (1608)
R043	1-216-864-91	s	CONDUCTOR, CHIP (1608)
R044	1-216-809-91	s	RES, CHIP 100 (1608)
R045	1-216-821-91	s	RES, CHIP 1.0K (1608)
R046	1-216-821-91	s	RES, CHIP 1.0K (1608)
R047	1-216-801-91	s	RES, CHIP 22 (1608)
R049	1-216-864-91	s	CONDUCTOR, CHIP (1608)
R050	1-216-801-91	s	RES, CHIP 22 (1608)
R052	1-216-864-91	s	CONDUCTOR, CHIP (1608)
R053	1-216-864-91	s	CONDUCTOR, CHIP (1608)
R054	1-216-864-91	s	CONDUCTOR, CHIP (1608)
R055	1-216-864-91	s	CONDUCTOR, CHIP (1608)
R056	1-216-797-91	s	RES, CHIP 10 (1608)
R058	1-216-801-91	s	RES, CHIP 22 (1608)
R059	1-216-801-91	s	RES, CHIP 22 (1608)
R060	1-216-829-91	s	RES, CHIP 4.7K (1608)
R061	1-216-801-91	s	RES, CHIP 22 (1608)
R062	1-216-825-91	s	RES, CHIP 2.2K (1608)
R063	1-216-807-91	s	RES, CHIP 68 (1608)
R064	1-216-807-91	s	RES, CHIP 68 (1608)
R065	1-216-807-91	s	RES, CHIP 68 (1608)
R066	1-216-807-91	s	RES, CHIP 68 (1608)
R067	1-216-807-91	s	RES, CHIP 68 (1608)
R068	1-216-807-91	s	RES, CHIP 68 (1608)
R069	1-216-807-91	s	RES, CHIP 68 (1608)
R070	1-216-807-91	s	RES, CHIP 68 (1608)
R071	1-216-801-91	s	RES, CHIP 22 (1608)
R072	1-216-809-91	s	RES, CHIP 100 (1608)
R073	1-216-801-91	s	RES, CHIP 22 (1608)
R074	1-216-807-91	s	RES, CHIP 68 (1608)
R075	1-216-807-91	s	RES, CHIP 68 (1608)
R076	1-216-801-91	s	RES, CHIP 22 (1608)
R077	1-216-807-91	s	RES, CHIP 68 (1608)
R078	1-216-801-91	s	RES, CHIP 22 (1608)
R079	1-216-837-91	s	RES, CHIP 22K (1608)

(BK BOARD)

Ref. No. or Q'ty	Part No.	SP Description
R080	1-216-801-91	s RES, CHIP 22 (1608)
R081	1-216-829-91	s RES, CHIP 4.7K (1608)
R082	1-216-829-91	s RES, CHIP 4.7K (1608)
R084	1-216-829-91	s RES, CHIP 4.7K (1608)
R089	1-216-829-91	s RES, CHIP 4.7K (1608)
R090	1-216-837-91	s RES, CHIP 22K (1608)
R091	1-216-837-91	s RES, CHIP 22K (1608)
R094	1-218-875-91	s RES, CHIP 15K (1608)
R099	1-218-907-91	s RES, CHIP 330K (1608)
R100	1-218-827-91	s RES, CHIP 150 (1608)
R101	1-216-809-91	s RES, CHIP 100 (1608)
R102	1-218-827-91	s RES, CHIP 150 (1608)
R103	1-218-855-91	s RES, CHIP 2.2K (1608)
R104	1-218-837-91	s RES, CHIP 390 (1608)
R105	1-218-855-91	s RES, CHIP 2.2K (1608)
R106	1-216-833-91	s RES, CHIP 10K (1608)
R107	1-216-864-91	s CONDUCTOR, CHIP (1608)
R108	1-216-829-91	s RES, CHIP 4.7K (1608)
R109	1-216-864-91	s CONDUCTOR, CHIP (1608)
R110	1-218-849-91	s RES, CHIP 1.2K (1608)
R111	1-216-864-91	s CONDUCTOR, CHIP (1608)
R112	1-218-845-91	s RES, CHIP 820 (1608)
R113	1-216-864-91	s CONDUCTOR, CHIP (1608)
R114	1-218-851-91	s RES, CHIP 1.5K (1608)
R115	1-218-855-91	s RES, CHIP 2.2K (1608)
R116	1-218-837-91	s RES, CHIP 390 (1608)
R117	1-218-895-91	s RES, CHIP 100K (1608)
R118	1-218-847-91	s RES, CHIP 1.0K (1608)
R120	1-218-832-91	s RES, CHIP 240 (1608)
R121	1-218-837-91	s RES, CHIP 390 (1608)
R122	1-218-837-91	s RES, CHIP 390 (1608)
R123	1-218-837-91	s RES, CHIP 390 (1608)
R124	1-218-837-91	s RES, CHIP 390 (1608)
R125	1-216-864-91	s CONDUCTOR, CHIP (1608)
R126	1-216-864-91	s CONDUCTOR, CHIP (1608)
R127	1-216-864-91	s CONDUCTOR, CHIP (1608)
R128	1-216-864-91	s CONDUCTOR, CHIP (1608)
R129	1-216-864-91	s CONDUCTOR, CHIP (1608)
R130	1-216-864-91	s CONDUCTOR, CHIP (1608)
R132	1-218-861-91	s RES, CHIP 3.9K (1608)
R133	1-211-977-91	s RES, CHIP 22 (1608)
R134	1-218-847-91	s RES, CHIP 1.0K (1608)
R135	1-218-863-91	s RES, CHIP 4.7K (1608)
R137	1-218-897-91	s RES, CHIP 120K (1608)
R138	1-218-891-91	s RES, CHIP 68K (1608)
R139	1-218-873-91	s RES, CHIP 12K (1608)
R140	1-218-835-91	s RES, CHIP 330 (1608)
R141	1-218-831-91	s RES, CHIP 220 (1608)
R149	1-218-833-91	s RES, CHIP 270 (1608)
R150	1-216-821-91	s RES, CHIP 1.0K (1608)
R151	1-216-833-91	s RES, CHIP 10K (1608)
R152	1-216-813-91	s RES, CHIP 220 (1608)
R153	1-218-855-91	s RES, CHIP 2.2K (1608)
R154	1-216-864-91	s CONDUCTOR, CHIP (1608)
R155	1-218-851-91	s RES, CHIP 1.5K (1608)
R156	1-218-845-91	s RES, CHIP 820 (1608)
R157	1-218-847-91	s RES, CHIP 1.0K (1608)
R158	1-216-864-91	s CONDUCTOR, CHIP (1608)
R159	1-216-829-91	s RES, CHIP 4.7K (1608)

(BK BOARD)

Ref. No. or Q'ty	Part No.	SP Description
R160	1-216-821-91	s RES, CHIP 1.0K (1608)
R161	1-216-822-91	s RES, CHIP 1.2K (1608)
R162	1-216-845-91	s RES, CHIP 100K (1608)
R163	1-216-809-91	s RES, CHIP 100 (1608)
R164	1-216-864-91	s CONDUCTOR, CHIP (1608)
R165	1-216-845-91	s RES, CHIP 100K (1608)
R166	1-216-864-91	s CONDUCTOR, CHIP (1608)
R167	1-218-853-91	s RES, CHIP 1.8K (1608)
R168	1-218-875-91	s RES, CHIP 15K (1608)
R169	1-218-867-91	s RES, CHIP 6.8K (1608)
R170	1-218-875-91	s RES, CHIP 15K (1608)
R171	1-216-864-91	s CONDUCTOR, CHIP (1608)
R172	1-216-864-91	s CONDUCTOR, CHIP (1608)
R173	1-216-809-91	s RES, CHIP 100 (1608)
R174	1-218-895-91	s RES, CHIP 100K (1608)
R175	1-216-817-91	s RES, CHIP 470 (1608)
R176	1-216-817-91	s RES, CHIP 470 (1608)
R177	1-216-820-91	s RES, CHIP 820 (1608)
R178	1-218-860-91	s RES, CHIP 3.6K (1608)
R179	1-218-851-91	s RES, CHIP 1.5K (1608)
R181	1-218-823-91	s RES, CHIP 100 (1608)
R200	1-218-855-91	s RES, CHIP 2.2K (1608)
R201	1-218-855-91	s RES, CHIP 2.2K (1608)
R202	1-216-833-91	s RES, CHIP 10K (1608)
R203	1-216-829-91	s RES, CHIP 4.7K (1608)
R204	1-216-864-91	s CONDUCTOR, CHIP (1608)
R205	1-216-864-91	s CONDUCTOR, CHIP (1608)
R206	1-216-864-91	s CONDUCTOR, CHIP (1608)
R207	1-216-864-91	s CONDUCTOR, CHIP (1608)
R208	1-218-849-91	s RES, CHIP 1.2K (1608)
R209	1-218-845-91	s RES, CHIP 820 (1608)
R210	1-216-864-91	s CONDUCTOR, CHIP (1608)
R211	1-218-851-91	s RES, CHIP 1.5K (1608)
R212	1-218-855-91	s RES, CHIP 2.2K (1608)
R213	1-218-837-91	s RES, CHIP 390 (1608)
R214	1-216-864-91	s CONDUCTOR, CHIP (1608)
R215	1-218-895-91	s RES, CHIP 100K (1608)
R216	1-218-823-91	s RES, CHIP 100 (1608)
R218	1-218-847-91	s RES, CHIP 1.0K (1608)
R219	1-218-907-91	s RES, CHIP 330K (1608)
R220	1-216-864-91	s CONDUCTOR, CHIP (1608)
R221	1-216-864-91	s CONDUCTOR, CHIP (1608)
R300	1-218-827-91	s RES, CHIP 150 (1608)
R301	1-216-809-91	s RES, CHIP 100 (1608)
R302	1-218-827-91	s RES, CHIP 150 (1608)
R303	1-218-837-91	s RES, CHIP 390 (1608)
R304	1-218-856-91	s RES, CHIP 2.4K (1608)
R305	1-216-820-91	s RES, CHIP 820 (1608)
R306	1-216-833-91	s RES, CHIP 10K (1608)
R307	1-216-864-91	s CONDUCTOR, CHIP (1608)
R308	1-216-829-91	s RES, CHIP 4.7K (1608)
R309	1-216-864-91	s CONDUCTOR, CHIP (1608)
R310	1-216-864-91	s CONDUCTOR, CHIP (1608)
R311	1-218-849-91	s RES, CHIP 1.2K (1608)
R312	1-218-845-91	s RES, CHIP 820 (1608)
R313	1-216-864-91	s CONDUCTOR, CHIP (1608)
R314	1-218-851-91	s RES, CHIP 1.5K (1608)
R315	1-218-855-91	s RES, CHIP 2.2K (1608)
R316	1-218-837-91	s RES, CHIP 390 (1608)

(BK BOARD)

Ref. No. or Q'ty	Part No.	SP	Description
R317	1-218-895-91	s	RES, CHIP 100K (1608)
R318	1-218-847-91	s	RES, CHIP 1.0K (1608)
R320	1-218-837-91	s	RES, CHIP 390 (1608)
R321	1-218-837-91	s	RES, CHIP 390 (1608)
R322	1-218-837-91	s	RES, CHIP 390 (1608)
R323	1-218-840-91	s	RES, CHIP 510 (1608)
R324	1-218-837-91	s	RES, CHIP 390 (1608)
R325	1-218-847-91	s	RES, CHIP 1.0K (1608)
R326	1-216-864-91	s	CONDUCTOR, CHIP (1608)
R327	1-216-864-91	s	CONDUCTOR, CHIP (1608)
R328	1-216-864-91	s	CONDUCTOR, CHIP (1608)
R329	1-216-864-91	s	CONDUCTOR, CHIP (1608)
R330	1-216-864-91	s	CONDUCTOR, CHIP (1608)
R331	1-216-864-91	s	CONDUCTOR, CHIP (1608)
R333	1-218-861-91	s	RES, CHIP 3.9K (1608)
R334	1-211-977-91	s	RES, CHIP 22 (1608)
R335	1-218-847-91	s	RES, CHIP 1.0K (1608)
R336	1-218-863-91	s	RES, CHIP 4.7K (1608)
R338	1-218-897-91	s	RES, CHIP 120K (1608)
R339	1-218-891-91	s	RES, CHIP 68K (1608)
R340	1-218-873-91	s	RES, CHIP 12K (1608)
R341	1-218-835-91	s	RES, CHIP 330 (1608)
R342	1-218-831-91	s	RES, CHIP 220 (1608)
R349	1-218-833-91	s	RES, CHIP 270 (1608)
R350	1-216-821-91	s	RES, CHIP 1.0K (1608)
R351	1-216-833-91	s	RES, CHIP 10K (1608)
R352	1-216-813-91	s	RES, CHIP 220 (1608)
R353	1-218-855-91	s	RES, CHIP 2.2K (1608)
R354	1-216-864-91	s	CONDUCTOR, CHIP (1608)
R355	1-218-851-91	s	RES, CHIP 1.5K (1608)
R356	1-218-845-91	s	RES, CHIP 820 (1608)
R357	1-218-847-91	s	RES, CHIP 1.0K (1608)
R358	1-216-864-91	s	CONDUCTOR, CHIP (1608)
R359	1-216-829-91	s	RES, CHIP 4.7K (1608)
R360	1-216-821-91	s	RES, CHIP 1.0K (1608)
R361	1-216-822-91	s	RES, CHIP 1.2K (1608)
R362	1-216-845-91	s	RES, CHIP 100K (1608)
R363	1-216-809-91	s	RES, CHIP 100 (1608)
R364	1-216-864-91	s	CONDUCTOR, CHIP (1608)
R365	1-216-845-91	s	RES, CHIP 100K (1608)
R366	1-216-864-91	s	CONDUCTOR, CHIP (1608)
R367	1-218-853-91	s	RES, CHIP 1.8K (1608)
R368	1-218-875-91	s	RES, CHIP 15K (1608)
R369	1-218-867-91	s	RES, CHIP 6.8K (1608)
R370	1-218-875-91	s	RES, CHIP 15K (1608)
R371	1-216-864-91	s	CONDUCTOR, CHIP (1608)
R372	1-216-864-91	s	CONDUCTOR, CHIP (1608)
R373	1-216-809-91	s	RES, CHIP 100 (1608)
R374	1-218-895-91	s	RES, CHIP 100K (1608)
R375	1-216-817-91	s	RES, CHIP 470 (1608)
R376	1-216-817-91	s	RES, CHIP 470 (1608)
R377	1-218-823-91	s	RES, CHIP 100 (1608)
R400	1-218-855-91	s	RES, CHIP 2.2K (1608)
R401	1-218-855-91	s	RES, CHIP 2.2K (1608)
R402	1-216-833-91	s	RES, CHIP 10K (1608)
R403	1-216-829-91	s	RES, CHIP 4.7K (1608)
R404	1-216-864-91	s	CONDUCTOR, CHIP (1608)
R405	1-216-864-91	s	CONDUCTOR, CHIP (1608)
R406	1-216-864-91	s	CONDUCTOR, CHIP (1608)

(BK BOARD)

Ref. No. or Q'ty	Part No.	SP	Description
R407	1-216-864-91	s	CONDUCTOR, CHIP (1608)
R408	1-218-849-91	s	RES, CHIP 1.2K (1608)
R409	1-218-845-91	s	RES, CHIP 820 (1608)
R410	1-216-864-91	s	CONDUCTOR, CHIP (1608)
R411	1-218-851-91	s	RES, CHIP 1.5K (1608)
R412	1-218-855-91	s	RES, CHIP 2.2K (1608)
R413	1-218-837-91	s	RES, CHIP 390 (1608)
R414	1-216-864-91	s	CONDUCTOR, CHIP (1608)
R415	1-218-895-91	s	RES, CHIP 100K (1608)
R416	1-218-823-91	s	RES, CHIP 100 (1608)
R417	1-218-907-91	s	RES, CHIP 330K (1608)
R418	1-218-847-91	s	RES, CHIP 1.0K (1608)
R420	1-216-864-91	s	CONDUCTOR, CHIP (1608)
R421	1-216-864-91	s	CONDUCTOR, CHIP (1608)
R500	1-218-827-91	s	RES, CHIP 150 (1608)
R501	1-216-809-91	s	RES, CHIP 100 (1608)
R502	1-218-827-91	s	RES, CHIP 150 (1608)
R503	1-218-837-91	s	RES, CHIP 390 (1608)
R504	1-218-855-91	s	RES, CHIP 2.2K (1608)
R505	1-218-855-91	s	RES, CHIP 2.2K (1608)
R506	1-216-833-91	s	RES, CHIP 10K (1608)
R507	1-216-864-91	s	CONDUCTOR, CHIP (1608)
R508	1-216-829-91	s	RES, CHIP 4.7K (1608)
R509	1-216-864-91	s	CONDUCTOR, CHIP (1608)
R510	1-216-864-91	s	CONDUCTOR, CHIP (1608)
R511	1-218-849-91	s	RES, CHIP 1.2K (1608)
R512	1-218-845-91	s	RES, CHIP 820 (1608)
R513	1-216-864-91	s	CONDUCTOR, CHIP (1608)
R514	1-218-851-91	s	RES, CHIP 1.5K (1608)
R515	1-218-855-91	s	RES, CHIP 2.2K (1608)
R516	1-218-837-91	s	RES, CHIP 390 (1608)
R517	1-218-895-91	s	RES, CHIP 100K (1608)
R518	1-218-847-91	s	RES, CHIP 1.0K (1608)
R520	1-216-864-91	s	CONDUCTOR, CHIP (1608)
R521	1-218-830-91	s	RES, CHIP 200 (1608)
R522	1-216-864-91	s	CONDUCTOR, CHIP (1608)
R523	1-218-837-91	s	RES, CHIP 390 (1608)
R524	1-218-837-91	s	RES, CHIP 390 (1608)
R525	1-218-837-91	s	RES, CHIP 390 (1608)
R526	1-218-837-91	s	RES, CHIP 390 (1608)
R527	1-216-864-91	s	CONDUCTOR, CHIP (1608)
R528	1-216-864-91	s	CONDUCTOR, CHIP (1608)
R529	1-216-864-91	s	CONDUCTOR, CHIP (1608)
R530	1-216-864-91	s	CONDUCTOR, CHIP (1608)
R531	1-216-864-91	s	CONDUCTOR, CHIP (1608)
R532	1-216-864-91	s	CONDUCTOR, CHIP (1608)
R534	1-218-861-91	s	RES, CHIP 3.9K (1608)
R535	1-211-977-91	s	RES, CHIP 22 (1608)
R536	1-218-847-91	s	RES, CHIP 1.0K (1608)
R537	1-218-863-91	s	RES, CHIP 4.7K (1608)
R539	1-218-897-91	s	RES, CHIP 120K (1608)
R540	1-218-891-91	s	RES, CHIP 68K (1608)
R541	1-218-873-91	s	RES, CHIP 12K (1608)
R542	1-218-835-91	s	RES, CHIP 330 (1608)
R543	1-218-831-91	s	RES, CHIP 220 (1608)
R544	1-218-907-91	s	RES, CHIP 330K (1608)
R549	1-218-833-91	s	RES, CHIP 270 (1608)
R550	1-216-821-91	s	RES, CHIP 1.0K (1608)
R551	1-216-833-91	s	RES, CHIP 10K (1608)

(BK BOARD)

Ref. No. or Q'ty	Part No.	SP Description
R552	1-216-813-91	s RES, CHIP 220 (1608)
R553	1-218-855-91	s RES, CHIP 2.2K (1608)
R554	1-216-864-91	s CONDUCTOR, CHIP (1608)
R555	1-218-851-91	s RES, CHIP 1.5K (1608)
R556	1-218-845-91	s RES, CHIP 820 (1608)
R557	1-218-847-91	s RES, CHIP 1.0K (1608)
R558	1-216-864-91	s CONDUCTOR, CHIP (1608)
R559	1-216-829-91	s RES, CHIP 4.7K (1608)
R560	1-216-821-91	s RES, CHIP 1.0K (1608)
R561	1-216-822-91	s RES, CHIP 1.2K (1608)
R562	1-216-845-91	s RES, CHIP 100K (1608)
R563	1-216-809-91	s RES, CHIP 100 (1608)
R564	1-216-864-91	s CONDUCTOR, CHIP (1608)
R565	1-216-845-91	s RES, CHIP 100K (1608)
R566	1-216-864-91	s CONDUCTOR, CHIP (1608)
R567	1-218-853-91	s RES, CHIP 1.8K (1608)
R568	1-218-875-91	s RES, CHIP 15K (1608)
R569	1-218-867-91	s RES, CHIP 6.8K (1608)
R570	1-218-875-91	s RES, CHIP 15K (1608)
R571	1-216-864-91	s CONDUCTOR, CHIP (1608)
R572	1-216-864-91	s CONDUCTOR, CHIP (1608)
R573	1-216-809-91	s RES, CHIP 100 (1608)
R574	1-218-895-91	s RES, CHIP 100K (1608)
R575	1-216-817-91	s RES, CHIP 470 (1608)
R576	1-216-817-91	s RES, CHIP 470 (1608)
R577	1-218-823-91	s RES, CHIP 100 (1608)
R600	1-216-857-91	s RES, CHIP 1.0M (1608)
R601	1-218-861-91	s RES, CHIP 3.9K (1608)
R602	1-216-834-91	s RES, CHIP 12K (1608)
R603	1-216-813-91	s RES, CHIP 220 (1608)
R604	1-218-883-91	s RES, CHIP 33K (1608)
R605	1-218-869-91	s RES, CHIP 8.2K (1608)
R607	1-216-813-91	s RES, CHIP 220 (1608)
R608	1-218-873-91	s RES, CHIP 12K (1608)
R609	1-218-875-91	s RES, CHIP 15K (1608)
R610	1-218-871-91	s RES, CHIP 10K (1608)
R611	1-218-847-91	s RES, CHIP 1.0K (1608)
R612	1-218-873-91	s RES, CHIP 12K (1608)
R613	1-216-864-91	s CONDUCTOR, CHIP (1608)
R614	1-218-861-91	s RES, CHIP 3.9K (1608)
R616	1-216-864-91	s CONDUCTOR, CHIP (1608)
R617	1-218-871-91	s RES, CHIP 10K (1608)
R618	1-218-871-91	s RES, CHIP 10K (1608)
R619	1-216-864-91	s CONDUCTOR, CHIP (1608)
R621	1-218-919-91	s RES, CHIP 1M (1608)
R622	1-218-851-91	s RES, CHIP 1.5K (1608)
R650	1-216-864-91	s CONDUCTOR, CHIP (1608)
R651	1-216-864-91	s CONDUCTOR, CHIP (1608)
R652	1-216-821-91	s RES, CHIP 1.0K (1608)
R653	1-216-833-91	s RES, CHIP 10K (1608)
R654	1-218-871-91	s RES, CHIP 10K (1608)
R655	1-218-871-91	s RES, CHIP 10K (1608)
R656	1-216-821-91	s RES, CHIP 1.0K (1608)
R657	1-216-830-91	s RES, CHIP 5.6K (1608)
R658	1-216-821-91	s RES, CHIP 1.0K (1608)
R659	1-216-864-91	s CONDUCTOR, CHIP (1608)
R660	1-216-864-91	s CONDUCTOR, CHIP (1608)
R661	1-216-845-91	s RES, CHIP 100K (1608)
R662	1-216-825-91	s RES, CHIP 2.2K (1608)

(BK BOARD)

Ref. No. or Q'ty	Part No.	SP Description
R663	1-218-855-91	s RES, CHIP 2.2K (1608)
R664	1-216-864-91	s CONDUCTOR, CHIP (1608)
R665	1-216-864-91	s CONDUCTOR, CHIP (1608)
R666	1-216-825-91	s RES, CHIP 2.2K (1608)
R667	1-216-809-91	s RES, CHIP 100 (1608)
R668	1-218-871-91	s RES, CHIP 10K (1608)
R669	1-216-827-91	s RES, CHIP 3.3K (1608)
R670	1-218-871-91	s RES, CHIP 10K (1608)
R700	1-216-864-91	s CONDUCTOR, CHIP (1608)
R701	1-216-864-91	s CONDUCTOR, CHIP (1608)
R702	1-216-864-91	s CONDUCTOR, CHIP (1608)
R703	1-216-801-91	s RES, CHIP 22 (1608)
R704	1-216-801-91	s RES, CHIP 22 (1608)
R705	1-216-801-91	s RES, CHIP 22 (1608)
R706	1-216-801-91	s RES, CHIP 22 (1608)
R707	1-216-837-91	s RES, CHIP 22K (1608)
R708	1-216-801-91	s RES, CHIP 22 (1608)
R709	1-216-801-91	s RES, CHIP 22 (1608)
R710	1-216-801-91	s RES, CHIP 22 (1608)
R711	1-216-801-91	s RES, CHIP 22 (1608)
R712	1-216-829-91	s RES, CHIP 4.7K (1608)
R713	1-216-801-91	s RES, CHIP 22 (1608)
R714	1-216-801-91	s RES, CHIP 22 (1608)
R715	1-216-864-91	s CONDUCTOR, CHIP (1608)
R716	1-216-864-91	s CONDUCTOR, CHIP (1608)
R717	1-216-864-91	s CONDUCTOR, CHIP (1608)
R718	1-216-864-91	s CONDUCTOR, CHIP (1608)
R719	1-216-815-91	s RES, CHIP 330 (1608)
R720	1-216-845-91	s RES, CHIP 100K (1608)
R721	1-216-864-91	s CONDUCTOR, CHIP (1608)
R722	1-218-855-91	s RES, CHIP 2.2K (1608)
R723	1-216-864-91	s CONDUCTOR, CHIP (1608)
R724	1-216-845-91	s RES, CHIP 100K (1608)
R725	1-216-864-91	s CONDUCTOR, CHIP (1608)
R726	1-216-864-91	s CONDUCTOR, CHIP (1608)
R727	1-216-829-91	s RES, CHIP 4.7K (1608)
R728	1-216-829-91	s RES, CHIP 4.7K (1608)
R729	1-216-829-91	s RES, CHIP 4.7K (1608)
R730	1-216-809-91	s RES, CHIP 100 (1608)
R731	1-216-829-91	s RES, CHIP 4.7K (1608)
R732	1-218-855-91	s RES, CHIP 2.2K (1608)
R733	1-211-977-91	s RES, CHIP 22 (1608)
R734	1-211-977-91	s RES, CHIP 22 (1608)
R735	1-211-977-91	s RES, CHIP 22 (1608)
R741	1-216-815-91	s RES, CHIP 330 (1608)
R742	1-216-864-91	s CONDUCTOR, CHIP (1608)
R743	1-216-797-91	s RES, CHIP 10 (1608)
R744	1-216-864-91	s CONDUCTOR, CHIP (1608)
R745	1-216-829-91	s RES, CHIP 4.7K (1608)
R746	1-216-815-91	s RES, CHIP 330 (1608)
R747	1-216-864-91	s CONDUCTOR, CHIP (1608)
R748	1-216-829-91	s RES, CHIP 4.7K (1608)
R749	1-216-864-91	s CONDUCTOR, CHIP (1608)
R751	1-216-845-91	s RES, CHIP 100K (1608)
R752	1-216-864-91	s CONDUCTOR, CHIP (1608)
R753	1-216-857-91	s RES, CHIP 1.0M (1608)
R754	1-218-863-91	s RES, CHIP 4.7K (1608)
R755	1-218-861-91	s RES, CHIP 3.9K (1608)
R756	1-218-871-91	s RES, CHIP 10K (1608)

(BK BOARD)

Ref. No. or Q'ty	Part No.	SP Description
R757	1-216-797-91	s RES, CHIP 10 (1608)
R758	1-218-863-91	s RES, CHIP 4.7K (1608)
R759	1-218-869-91	s RES, CHIP 8.2K (1608)
R760	1-216-864-91	s CONDUCTOR, CHIP (1608)
R761	1-218-861-91	s RES, CHIP 3.9K (1608)
R762	1-218-861-91	s RES, CHIP 3.9K (1608)
R763	1-218-861-91	s RES, CHIP 3.9K (1608)
R764	1-218-861-91	s RES, CHIP 3.9K (1608)
R765	1-218-861-91	s RES, CHIP 3.9K (1608)
R766	1-218-861-91	s RES, CHIP 3.9K (1608)
R767	1-218-861-91	s RES, CHIP 3.9K (1608)
R768	1-218-861-91	s RES, CHIP 3.9K (1608)
R769	1-218-861-91	s RES, CHIP 3.9K (1608)
R770	1-218-861-91	s RES, CHIP 3.9K (1608)
R771	1-218-861-91	s RES, CHIP 3.9K (1608)
R772	1-216-815-91	s RES, CHIP 330 (1608)
R800	1-216-833-91	s RES, CHIP 10K (1608)
R801	1-216-833-91	s RES, CHIP 10K (1608)
R804	1-218-889-91	s RES, CHIP 56K (1608)
R805	1-218-907-91	s RES, CHIP 330K (1608)
R806	1-218-867-91	s RES, CHIP 6.8K (1608)
R807	1-218-901-91	s RES, CHIP 180K (1608)
R808	1-218-873-91	s RES, CHIP 12K (1608)
R809	1-218-879-91	s RES, CHIP 22K (1608)
R810	1-218-875-91	s RES, CHIP 15K (1608)
R811	1-216-821-91	s RES, CHIP 1.0K (1608)
R812	1-218-849-91	s RES, CHIP 1.2K (1608)
R813	1-218-875-91	s RES, CHIP 15K (1608)
R814	1-218-861-91	s RES, CHIP 3.9K (1608)
R815	1-218-863-91	s RES, CHIP 4.7K (1608)
R816	1-216-864-91	s CONDUCTOR, CHIP (1608)
R817	1-216-793-91	s RES, CHIP 4.7 (1608)
R818	1-216-833-91	s RES, CHIP 10K (1608)
R819	1-216-833-91	s RES, CHIP 10K (1608)
R820	1-216-793-91	s RES, CHIP 4.7 (1608)
R822	1-216-864-91	s CONDUCTOR, CHIP (1608)
R823	1-216-837-91	s RES, CHIP 22K (1608)
R824	1-216-809-91	s RES, CHIP 100 (1608)
R825	1-219-706-21	s RES, CHIP (SQUARE TYPE) 0.10
R826	1-218-871-91	s RES, CHIP 10K (1608)
R828	1-218-849-91	s RES, CHIP 1.2K (1608)
R829	1-218-887-91	s RES, CHIP 47K (1608)
R830	1-216-841-91	s RES, CHIP 47K (1608)
R900	1-216-805-91	s RES, CHIP 47 (1608)
R901	1-216-805-91	s RES, CHIP 47 (1608)
R902	1-216-833-91	s RES, CHIP 10K (1608)
R903	1-216-833-91	s RES, CHIP 10K (1608)
R904	1-216-801-91	s RES, CHIP 22 (1608)
R905	1-216-801-91	s RES, CHIP 22 (1608)
R906	1-216-801-91	s RES, CHIP 22 (1608)
R907	1-216-801-91	s RES, CHIP 22 (1608)
R908	1-216-801-91	s RES, CHIP 22 (1608)
R909	1-216-801-91	s RES, CHIP 22 (1608)
R910	1-216-801-91	s RES, CHIP 22 (1608)
R911	1-216-801-91	s RES, CHIP 22 (1608)
R912	1-216-801-91	s RES, CHIP 22 (1608)
R913	1-216-809-91	s RES, CHIP 100 (1608)
R914	1-216-864-91	s CONDUCTOR, CHIP (1608)
R915	1-216-833-91	s RES, CHIP 10K (1608)

(BK BOARD)

Ref. No. or Q'ty	Part No.	SP Description
R916	1-216-833-91	s RES, CHIP 10K (1608)
R917	1-216-805-91	s RES, CHIP 47 (1608)
R918	1-216-801-91	s RES, CHIP 22 (1608)
R919	1-216-801-91	s RES, CHIP 22 (1608)
R920	1-216-805-91	s RES, CHIP 47 (1608)
R921	1-216-805-91	s RES, CHIP 47 (1608)
R922	1-216-805-91	s RES, CHIP 47 (1608)
R923	1-216-805-91	s RES, CHIP 47 (1608)
R924	1-216-809-91	s RES, CHIP 100 (1608)
R925	1-216-829-91	s RES, CHIP 4.7K (1608)
R926	1-216-833-91	s RES, CHIP 10K (1608)
R927	1-216-833-91	s RES, CHIP 10K (1608)
R928	1-216-833-91	s RES, CHIP 10K (1608)
R929	1-216-809-91	s RES, CHIP 100 (1608)
R930	1-216-833-91	s RES, CHIP 10K (1608)
R931	1-218-861-91	s RES, CHIP 3.9K (1608)
R932	1-218-861-91	s RES, CHIP 3.9K (1608)
R933	1-218-861-91	s RES, CHIP 3.9K (1608)
R934	1-218-861-91	s RES, CHIP 3.9K (1608)
R935	1-218-861-91	s RES, CHIP 3.9K (1608)
R936	1-218-861-91	s RES, CHIP 3.9K (1608)
R937	1-216-817-91	s RES, CHIP 470 (1608)
R938	1-216-817-91	s RES, CHIP 470 (1608)
R939	1-216-797-91	s RES, CHIP 10 (1608)
R940	1-218-863-91	s RES, CHIP 4.7K (1608)
R941	1-218-869-91	s RES, CHIP 8.2K (1608)
R942	1-216-857-91	s RES, CHIP 1.0M (1608)
R943	1-218-863-91	s RES, CHIP 4.7K (1608)
R944	1-218-861-91	s RES, CHIP 3.9K (1608)
R945	1-218-871-91	s RES, CHIP 10K (1608)
R946	1-216-864-91	s CONDUCTOR, CHIP (1608)
R947	1-218-861-91	s RES, CHIP 3.9K (1608)
R948	1-218-861-91	s RES, CHIP 3.9K (1608)
R949	1-218-861-91	s RES, CHIP 3.9K (1608)
R950	1-218-861-91	s RES, CHIP 3.9K (1608)
R951	1-218-861-91	s RES, CHIP 3.9K (1608)
R952	1-216-864-91	s CONDUCTOR, CHIP (1608)
R953	1-216-864-91	s CONDUCTOR, CHIP (1608)
R954	1-216-817-91	s RES, CHIP 470 (1608)
R955	1-216-817-91	s RES, CHIP 470 (1608)
R956	1-216-797-91	s RES, CHIP 10 (1608)
R957	1-218-873-91	s RES, CHIP 12K (1608)
R958	1-218-873-91	s RES, CHIP 12K (1608)
R959	1-216-833-91	s RES, CHIP 10K (1608)
R960	1-218-865-91	s RES, CHIP 5.6K (1608)
R961	1-218-865-91	s RES, CHIP 5.6K (1608)
R962	1-218-863-91	s RES, CHIP 4.7K (1608)
R963	1-218-869-91	s RES, CHIP 8.2K (1608)
R964	1-218-919-91	s RES, CHIP 1M (1608)
R965	1-216-813-91	s RES, CHIP 220 (1608)
R966	1-218-863-91	s RES, CHIP 4.7K (1608)
R967	1-216-813-91	s RES, CHIP 220 (1608)
R968	1-218-859-91	s RES, CHIP 3.3K (1608)
R969	1-218-859-91	s RES, CHIP 3.3K (1608)
R970	1-211-977-91	s RES, CHIP 22 (1608)
R971	1-211-977-91	s RES, CHIP 22 (1608)
R972	1-211-977-91	s RES, CHIP 22 (1608)
R973	1-216-837-91	s RES, CHIP 22K (1608)
R974	1-218-857-91	s RES, CHIP 2.7K (1608)

(BK BOARD)

Ref. No. or Q'ty	Part No.	SP Description
R975	1-218-857-91	s RES, CHIP 2.7K (1608)
R1000	1-216-833-91	s RES, CHIP 10K (1608)
R1001	1-216-833-91	s RES, CHIP 10K (1608)
R1004	1-218-881-91	s RES, CHIP 27K (1608)
R1005	1-218-905-91	s RES, CHIP 270K (1608)
R1006	1-218-867-91	s RES, CHIP 6.8K (1608)
R1007	1-218-901-91	s RES, CHIP 180K (1608)
R1008	1-218-873-91	s RES, CHIP 12K (1608)
R1009	1-218-879-91	s RES, CHIP 22K (1608)
R1010	1-218-875-91	s RES, CHIP 15K (1608)
R1011	1-216-821-91	s RES, CHIP 1.0K (1608)
R1012	1-218-849-91	s RES, CHIP 1.2K (1608)
R1013	1-218-875-91	s RES, CHIP 15K (1608)
R1014	1-218-861-91	s RES, CHIP 3.9K (1608)
R1015	1-218-863-91	s RES, CHIP 4.7K (1608)
R1016	1-216-864-91	s CONDUCTOR, CHIP (1608)
R1017	1-216-793-91	s RES, CHIP 4.7 (1608)
R1018	1-216-833-91	s RES, CHIP 10K (1608)
R1019	1-216-833-91	s RES, CHIP 10K (1608)
R1020	1-216-793-91	s RES, CHIP 4.7 (1608)
R1022	1-216-864-91	s CONDUCTOR, CHIP (1608)
R1024	1-216-809-91	s RES, CHIP 100 (1608)
R1025	1-219-706-21	s RES, CHIP (SQUARE TYPE) 0.10
R1026	1-218-871-91	s RES, CHIP 10K (1608)
R1028	1-218-849-91	s RES, CHIP 1.2K (1608)
R1029	1-218-887-91	s RES, CHIP 47K (1608)
R1030	1-216-837-91	s RES, CHIP 22K (1608)
R1031	1-216-841-91	s RES, CHIP 47K (1608)
R1099	1-218-823-91	s RES, CHIP 100 (1608)
R1100	1-216-809-91	s RES, CHIP 100 (1608)
R1102	1-216-864-91	s CONDUCTOR, CHIP (1608)
R1103	1-218-851-91	s RES, CHIP 1.5K (1608)
R1104	1-218-850-91	s RES, CHIP 1.3K (1608)
R1105	1-216-864-91	s CONDUCTOR, CHIP (1608)
R1106	1-216-864-91	s CONDUCTOR, CHIP (1608)
R1107	1-218-847-91	s RES, CHIP 1.0K (1608)
R1108	1-216-864-91	s CONDUCTOR, CHIP (1608)
R1109	1-218-851-91	s RES, CHIP 1.5K (1608)
R1110	1-218-848-91	s RES, CHIP 1.1K (1608)
R1111	1-218-823-91	s RES, CHIP 100 (1608)
R1114	1-218-847-91	s RES, CHIP 1.0K (1608)
R1115	1-216-864-91	s CONDUCTOR, CHIP (1608)
R1116	1-218-869-91	s RES, CHIP 8.2K (1608)
R1117	1-218-893-91	s RES, CHIP 82K (1608)
R1118	1-216-801-91	s RES, CHIP 22 (1608)
R1119	1-218-889-91	s RES, CHIP 56K (1608)
R1120	1-218-833-91	s RES, CHIP 270 (1608)
R1122	1-218-823-91	s RES, CHIP 100 (1608)
R1123	1-218-837-91	s RES, CHIP 390 (1608)
R1124	1-216-828-91	s RES, CHIP 3.9K (1608)
R1125	1-218-849-91	s RES, CHIP 1.2K (1608)
R1126	1-216-809-91	s RES, CHIP 100 (1608)
R1127	1-218-841-91	s RES, CHIP 560 (1608)
R1128	1-218-841-91	s RES, CHIP 560 (1608)
R1130	1-218-827-91	s RES, CHIP 150 (1608)
R1131	1-218-827-91	s RES, CHIP 150 (1608)
R1140	1-218-891-91	s RES, CHIP 68K (1608)
R1141	1-216-833-91	s RES, CHIP 10K (1608)
R1142	1-218-903-91	s RES, CHIP 220K (1608)

(BK BOARD)

Ref. No. or Q'ty	Part No.	SP Description
R1143	1-216-821-91	s RES, CHIP 1.0K (1608)
R1144	1-216-829-91	s RES, CHIP 4.7K (1608)
R1145	1-218-891-91	s RES, CHIP 68K (1608)
R1146	1-218-855-91	s RES, CHIP 2.2K (1608)
R1147	1-216-813-91	s RES, CHIP 220 (1608)
R1148	1-216-829-91	s RES, CHIP 4.7K (1608)
R1149	1-218-839-91	s RES, CHIP 470 (1608)
R1150	1-218-861-91	s RES, CHIP 3.9K (1608)
R1151	1-216-809-91	s RES, CHIP 100 (1608)
R1153	1-218-855-91	s RES, CHIP 2.2K (1608)
R1154	1-216-831-91	s RES, CHIP 6.8K (1608)
R1155	1-216-833-91	s RES, CHIP 10K (1608)
R1158	1-218-865-91	s RES, CHIP 5.6K (1608)
R1159	1-216-813-91	s RES, CHIP 220 (1608)
R1161	1-216-809-91	s RES, CHIP 100 (1608)
R1170	1-218-871-91	s RES, CHIP 10K (1608)
R1171	1-218-871-91	s RES, CHIP 10K (1608)
R1172	1-218-871-91	s RES, CHIP 10K (1608)
R1173	1-218-861-91	s RES, CHIP 3.9K (1608)
R1174	1-218-863-91	s RES, CHIP 4.7K (1608)
R1175	1-218-863-91	s RES, CHIP 4.7K (1608)
R1176	1-218-843-91	s RES, CHIP 680 (1608)
R1177	1-218-871-91	s RES, CHIP 10K (1608)
R1178	1-218-887-91	s RES, CHIP 47K (1608)
R1179	1-216-864-91	s CONDUCTOR, CHIP (1608)
R1180	1-216-833-91	s RES, CHIP 10K (1608)
R1181	1-216-837-91	s RES, CHIP 22K (1608)
R1182	1-216-813-91	s RES, CHIP 220 (1608)
R1183	1-218-869-91	s RES, CHIP 8.2K (1608)
R1184	1-218-873-91	s RES, CHIP 12K (1608)
R1185	1-218-867-91	s RES, CHIP 6.8K (1608)
R1186	1-218-899-91	s RES, CHIP 150K (1608)
R1187	1-218-893-91	s RES, CHIP 82K (1608)
R1188	1-218-851-91	s RES, CHIP 1.5K (1608)
R1189	1-216-829-91	s RES, CHIP 4.7K (1608)
R1190	1-218-837-91	s RES, CHIP 390 (1608)
R1300	1-216-809-91	s RES, CHIP 100 (1608)
R1302	1-216-864-91	s CONDUCTOR, CHIP (1608)
R1303	1-218-851-91	s RES, CHIP 1.5K (1608)
R1304	1-218-850-91	s RES, CHIP 1.3K (1608)
R1305	1-216-864-91	s CONDUCTOR, CHIP (1608)
R1306	1-216-864-91	s CONDUCTOR, CHIP (1608)
R1307	1-218-847-91	s RES, CHIP 1.0K (1608)
R1308	1-216-864-91	s CONDUCTOR, CHIP (1608)
R1309	1-218-851-91	s RES, CHIP 1.5K (1608)
R1310	1-218-848-91	s RES, CHIP 1.1K (1608)
R1311	1-218-847-91	s RES, CHIP 1.0K (1608)
R1312	1-216-864-91	s CONDUCTOR, CHIP (1608)
R1313	1-218-869-91	s RES, CHIP 8.2K (1608)
R1314	1-218-893-91	s RES, CHIP 82K (1608)
R1315	1-216-801-91	s RES, CHIP 22 (1608)
R1316	1-218-889-91	s RES, CHIP 56K (1608)
R1317	1-218-833-91	s RES, CHIP 270 (1608)
R1318	1-218-823-91	s RES, CHIP 100 (1608)
R1319	1-218-837-91	s RES, CHIP 390 (1608)
R1320	1-216-828-91	s RES, CHIP 3.9K (1608)
R1321	1-218-849-91	s RES, CHIP 1.2K (1608)
R1322	1-216-809-91	s RES, CHIP 100 (1608)
R1323	1-218-841-91	s RES, CHIP 560 (1608)

(BK BOARD)

Ref. No. or Q'ty	Part No.	SP	Description
R1325	1-218-827-91	s RES,	CHIP 150 (1608)
R1326	1-218-827-91	s RES,	CHIP 150 (1608)
R1327	1-218-841-91	s RES,	CHIP 560 (1608)
R1328	1-218-823-91	s RES,	CHIP 100 (1608)
R1329	1-218-823-91	s RES,	CHIP 100 (1608)
R1340	1-218-891-91	s RES,	CHIP 68K (1608)
R1341	1-216-833-91	s RES,	CHIP 10K (1608)
R1342	1-218-903-91	s RES,	CHIP 220K (1608)
R1343	1-216-821-91	s RES,	CHIP 1.0K (1608)
R1344	1-216-829-91	s RES,	CHIP 4.7K (1608)
R1345	1-218-891-91	s RES,	CHIP 68K (1608)
R1346	1-218-855-91	s RES,	CHIP 2.2K (1608)
R1347	1-216-813-91	s RES,	CHIP 220 (1608)
R1348	1-216-829-91	s RES,	CHIP 4.7K (1608)
R1349	1-218-839-91	s RES,	CHIP 470 (1608)
R1350	1-218-861-91	s RES,	CHIP 3.9K (1608)
R1351	1-216-809-91	s RES,	CHIP 100 (1608)
R1352	1-218-855-91	s RES,	CHIP 2.2K (1608)
R1353	1-216-831-91	s RES,	CHIP 6.8K (1608)
R1354	1-216-833-91	s RES,	CHIP 10K (1608)
R1356	1-218-865-91	s RES,	CHIP 5.6K (1608)
R1357	1-216-813-91	s RES,	CHIP 220 (1608)
R1358	1-216-809-91	s RES,	CHIP 100 (1608)
R1370	1-218-871-91	s RES,	CHIP 10K (1608)
R1371	1-218-871-91	s RES,	CHIP 10K (1608)
R1372	1-218-871-91	s RES,	CHIP 10K (1608)
R1373	1-218-861-91	s RES,	CHIP 3.9K (1608)
R1374	1-218-863-91	s RES,	CHIP 4.7K (1608)
R1375	1-218-863-91	s RES,	CHIP 4.7K (1608)
R1376	1-218-843-91	s RES,	CHIP 680 (1608)
R1377	1-218-871-91	s RES,	CHIP 10K (1608)
R1378	1-218-887-91	s RES,	CHIP 47K (1608)
R1379	1-216-864-91	s CONDUCTOR,	CHIP (1608)
R1380	1-216-833-91	s RES,	CHIP 10K (1608)
R1381	1-216-837-91	s RES,	CHIP 22K (1608)
R1382	1-216-813-91	s RES,	CHIP 220 (1608)
R1383	1-218-869-91	s RES,	CHIP 8.2K (1608)
R1384	1-218-873-91	s RES,	CHIP 12K (1608)
R1385	1-218-867-91	s RES,	CHIP 6.8K (1608)
R1386	1-218-899-91	s RES,	CHIP 150K (1608)
R1387	1-218-893-91	s RES,	CHIP 82K (1608)
R1388	1-218-851-91	s RES,	CHIP 1.5K (1608)
R1389	1-216-829-91	s RES,	CHIP 4.7K (1608)
R1390	1-218-837-91	s RES,	CHIP 390 (1608)
R1500	1-216-809-91	s RES,	CHIP 100 (1608)
R1502	1-216-864-91	s CONDUCTOR,	CHIP (1608)
R1503	1-218-851-91	s RES,	CHIP 1.5K (1608)
R1504	1-218-850-91	s RES,	CHIP 1.3K (1608)
R1505	1-216-864-91	s CONDUCTOR,	CHIP (1608)
R1506	1-216-864-91	s CONDUCTOR,	CHIP (1608)
R1507	1-218-847-91	s RES,	CHIP 1.0K (1608)
R1508	1-216-864-91	s CONDUCTOR,	CHIP (1608)
R1509	1-218-851-91	s RES,	CHIP 1.5K (1608)
R1510	1-218-848-91	s RES,	CHIP 1.1K (1608)
R1511	1-218-847-91	s RES,	CHIP 1.0K (1608)
R1512	1-216-864-91	s CONDUCTOR,	CHIP (1608)
R1513	1-218-869-91	s RES,	CHIP 8.2K (1608)
R1514	1-218-893-91	s RES,	CHIP 82K (1608)
R1515	1-216-801-91	s RES,	CHIP 22 (1608)

(BK BOARD)

Ref. No. or Q'ty	Part No.	SP	Description
R1516	1-218-889-91	s RES,	CHIP 56K (1608)
R1517	1-218-833-91	s RES,	CHIP 270 (1608)
R1518	1-218-823-91	s RES,	CHIP 100 (1608)
R1519	1-218-837-91	s RES,	CHIP 390 (1608)
R1520	1-216-828-91	s RES,	CHIP 3.9K (1608)
R1521	1-218-849-91	s RES,	CHIP 1.2K (1608)
R1522	1-216-809-91	s RES,	CHIP 100 (1608)
R1523	1-218-841-91	s RES,	CHIP 560 (1608)
R1525	1-218-827-91	s RES,	CHIP 150 (1608)
R1526	1-218-827-91	s RES,	CHIP 150 (1608)
R1527	1-218-841-91	s RES,	CHIP 560 (1608)
R1528	1-218-823-91	s RES,	CHIP 100 (1608)
R1529	1-218-823-91	s RES,	CHIP 100 (1608)
R1540	1-218-891-91	s RES,	CHIP 68K (1608)
R1541	1-216-833-91	s RES,	CHIP 10K (1608)
R1542	1-218-903-91	s RES,	CHIP 220K (1608)
R1543	1-216-821-91	s RES,	CHIP 1.0K (1608)
R1544	1-216-829-91	s RES,	CHIP 4.7K (1608)
R1545	1-218-891-91	s RES,	CHIP 68K (1608)
R1546	1-218-855-91	s RES,	CHIP 2.2K (1608)
R1547	1-216-813-91	s RES,	CHIP 220 (1608)
R1548	1-216-829-91	s RES,	CHIP 4.7K (1608)
R1549	1-218-839-91	s RES,	CHIP 470 (1608)
R1550	1-218-861-91	s RES,	CHIP 3.9K (1608)
R1551	1-216-809-91	s RES,	CHIP 100 (1608)
R1552	1-218-855-91	s RES,	CHIP 2.2K (1608)
R1553	1-216-831-91	s RES,	CHIP 6.8K (1608)
R1554	1-216-833-91	s RES,	CHIP 10K (1608)
R1556	1-218-865-91	s RES,	CHIP 5.6K (1608)
R1557	1-216-813-91	s RES,	CHIP 220 (1608)
R1558	1-216-809-91	s RES,	CHIP 100 (1608)
R1570	1-218-871-91	s RES,	CHIP 10K (1608)
R1571	1-218-871-91	s RES,	CHIP 10K (1608)
R1572	1-218-871-91	s RES,	CHIP 10K (1608)
R1573	1-218-861-91	s RES,	CHIP 3.9K (1608)
R1574	1-218-863-91	s RES,	CHIP 4.7K (1608)
R1575	1-218-863-91	s RES,	CHIP 4.7K (1608)
R1576	1-218-843-91	s RES,	CHIP 680 (1608)
R1577	1-218-871-91	s RES,	CHIP 10K (1608)
R1578	1-218-887-91	s RES,	CHIP 47K (1608)
R1579	1-216-864-91	s CONDUCTOR,	CHIP (1608)
R1580	1-216-833-91	s RES,	CHIP 10K (1608)
R1581	1-216-837-91	s RES,	CHIP 22K (1608)
R1582	1-216-813-91	s RES,	CHIP 220 (1608)
R1583	1-218-869-91	s RES,	CHIP 8.2K (1608)
R1584	1-218-873-91	s RES,	CHIP 12K (1608)
R1585	1-218-867-91	s RES,	CHIP 6.8K (1608)
R1586	1-218-899-91	s RES,	CHIP 150K (1608)
R1587	1-218-893-91	s RES,	CHIP 82K (1608)
R1588	1-218-851-91	s RES,	CHIP 1.5K (1608)
R1589	1-216-829-91	s RES,	CHIP 4.7K (1608)
R1590	1-218-837-91	s RES,	CHIP 390 (1608)
R1700	1-216-809-91	s RES,	CHIP 100 (1608)
R1701	1-216-828-91	s RES,	CHIP 3.9K (1608)
R1702	1-216-809-91	s RES,	CHIP 100 (1608)
R1703	1-218-858-91	s RES,	CHIP 3.0K (1608)
R1704	1-216-825-91	s RES,	CHIP 2.2K (1608)
R1705	1-211-989-91	s RES,	CHIP 68 (1608)
R1706	1-218-845-91	s RES,	CHIP 820 (1608)

(BK BOARD)

Ref. No. or Q'ty	Part No.	SP	Description
R1707	1-216-864-91	s	CONDUCTOR, CHIP (1608)
R1708	1-216-864-91	s	CONDUCTOR, CHIP (1608)
R1709	1-216-864-91	s	CONDUCTOR, CHIP (1608)
R1710	1-216-864-91	s	CONDUCTOR, CHIP (1608)
R1711	1-216-809-91	s	RES, CHIP 100 (1608)
R1712	1-211-989-91	s	RES, CHIP 68 (1608)
R1713	1-211-989-91	s	RES, CHIP 68 (1608)
R1714	1-216-825-91	s	RES, CHIP 2.2K (1608)
R1715	1-216-797-91	s	RES, CHIP 10 (1608)
R1716	1-216-825-91	s	RES, CHIP 2.2K (1608)
R1717	1-216-797-91	s	RES, CHIP 10 (1608)
R1718	1-218-858-91	s	RES, CHIP 3.0K (1608)
R1719	1-216-809-91	s	RES, CHIP 100 (1608)
R1720	1-218-845-91	s	RES, CHIP 820 (1608)
R1721	1-216-809-91	s	RES, CHIP 100 (1608)
R1722	1-216-828-91	s	RES, CHIP 3.9K (1608)
R1723	1-216-828-91	s	RES, CHIP 3.9K (1608)
R1724	1-216-821-91	s	RES, CHIP 1.0K (1608)
R1725	1-216-797-91	s	RES, CHIP 10 (1608)
R1726	1-218-859-91	s	RES, CHIP 3.3K (1608)
R1727	1-216-825-91	s	RES, CHIP 2.2K (1608)
R1728	1-218-830-91	s	RES, CHIP 200 (1608)
R1729	1-218-865-91	s	RES, CHIP 5.6K (1608)
R1730	1-218-846-91	s	RES, CHIP 910 (1608)
R1731	1-216-797-91	s	RES, CHIP 10 (1608)
R1732	1-216-797-91	s	RES, CHIP 10 (1608)
R1900	1-218-830-91	s	RES, CHIP 200 (1608)
R1901	1-218-830-91	s	RES, CHIP 200 (1608)
R1902	1-218-830-91	s	RES, CHIP 200 (1608)
R1903	1-216-864-91	s	CONDUCTOR, CHIP (1608)
R1904	1-216-864-91	s	CONDUCTOR, CHIP (1608)
R1905	1-216-864-91	s	CONDUCTOR, CHIP (1608)
R1906	1-216-864-91	s	CONDUCTOR, CHIP (1608)
R1907	1-218-847-91	s	RES, CHIP 1.0K (1608)
R1908	1-218-859-91	s	RES, CHIP 3.3K (1608)
R1909	1-218-851-91	s	RES, CHIP 1.5K (1608)
R1910	1-216-809-91	s	RES, CHIP 100 (1608)
R1911	1-216-809-91	s	RES, CHIP 100 (1608)
R1912	1-216-809-91	s	RES, CHIP 100 (1608)
R1913	1-216-828-91	s	RES, CHIP 3.9K (1608)
R1914	1-216-828-91	s	RES, CHIP 3.9K (1608)
R1915	1-216-828-91	s	RES, CHIP 3.9K (1608)
R1916	1-216-818-91	s	RES, CHIP 560 (1608)
R1917	1-216-818-91	s	RES, CHIP 560 (1608)
R1918	1-216-818-91	s	RES, CHIP 560 (1608)
R1919	1-216-818-91	s	RES, CHIP 560 (1608)
R1920	1-216-818-91	s	RES, CHIP 560 (1608)
R1921	1-216-818-91	s	RES, CHIP 560 (1608)
R1922	1-216-818-91	s	RES, CHIP 560 (1608)
R1923	1-216-818-91	s	RES, CHIP 560 (1608)
R1924	1-216-818-91	s	RES, CHIP 560 (1608)
R1925	1-216-825-91	s	RES, CHIP 2.2K (1608)
R1926	1-216-825-91	s	RES, CHIP 2.2K (1608)
R1927	1-216-825-91	s	RES, CHIP 2.2K (1608)
R1928	1-218-865-91	s	RES, CHIP 5.6K (1608)
R1929	1-218-865-91	s	RES, CHIP 5.6K (1608)
R1930	1-218-865-91	s	RES, CHIP 5.6K (1608)
R1931	1-218-863-91	s	RES, CHIP 4.7K (1608)
R1932	1-218-843-91	s	RES, CHIP 680 (1608)

(BK BOARD)

Ref. No. or Q'ty	Part No.	SP	Description
R1933	1-218-863-91	s	RES, CHIP 4.7K (1608)
R1934	1-218-843-91	s	RES, CHIP 680 (1608)
R1935	1-218-863-91	s	RES, CHIP 4.7K (1608)
R1936	1-218-843-91	s	RES, CHIP 680 (1608)
R1937	1-216-829-91	s	RES, CHIP 4.7K (1608)
R1938	1-216-822-91	s	RES, CHIP 1.2K (1608)
R1939	1-216-829-91	s	RES, CHIP 4.7K (1608)
R1940	1-216-822-91	s	RES, CHIP 1.2K (1608)
R1941	1-216-829-91	s	RES, CHIP 4.7K (1608)
R1942	1-216-822-91	s	RES, CHIP 1.2K (1608)
R1943	1-218-853-91	s	RES, CHIP 1.8K (1608)
R1944	1-218-859-91	s	RES, CHIP 3.3K (1608)
R1945	1-218-853-91	s	RES, CHIP 1.8K (1608)
R1946	1-218-853-91	s	RES, CHIP 1.8K (1608)
R1947	1-218-859-91	s	RES, CHIP 3.3K (1608)
R1948	1-218-859-91	s	RES, CHIP 3.3K (1608)
R1949	1-216-825-91	s	RES, CHIP 2.2K (1608)
R1950	1-216-825-91	s	RES, CHIP 2.2K (1608)
R1951	1-216-825-91	s	RES, CHIP 2.2K (1608)
R1952	1-216-809-91	s	RES, CHIP 100 (1608)
R1953	1-216-809-91	s	RES, CHIP 100 (1608)
R1954	1-216-809-91	s	RES, CHIP 100 (1608)
R1955	1-216-825-91	s	RES, CHIP 2.2K (1608)
R1956	1-216-825-91	s	RES, CHIP 2.2K (1608)
R1957	1-216-825-91	s	RES, CHIP 2.2K (1608)
R1959	1-216-833-91	s	RES, CHIP 10K (1608)
R1961	1-216-833-91	s	RES, CHIP 10K (1608)
R1963	1-216-833-91	s	RES, CHIP 10K (1608)
R2193	1-216-817-91	s	RES, CHIP 470 (1608)
R2194	1-216-817-91	s	RES, CHIP 470 (1608)
RB040	1-233-416-21	s	RES, CHIP NETWORK 22K (3216)
RB041	1-233-415-21	s	RES, CHIP NETWORK 10K (3216)
RB042	1-233-416-21	s	RES, CHIP NETWORK 22K (3216)
RB043	1-233-416-21	s	RES, CHIP NETWORK 22K (3216)
RB044	1-233-423-21	s	RES, CHIP NETWORK 47 (3216)
RB045	1-233-423-21	s	RES, CHIP NETWORK 47 (3216)
RB046	1-233-423-21	s	RES, CHIP NETWORK 47 (3216)
RB047	1-233-575-21	s	RES, CHIP NETWORK 22 (3216)
RB048	1-233-575-21	s	RES, CHIP NETWORK 22 (3216)
RB049	1-233-880-21	s	RES, NETWORK 68 (3216)
RB050	1-233-880-21	s	RES, NETWORK 68 (3216)
RB051	1-233-423-21	s	RES, CHIP NETWORK 47 (3216)
RB052	1-233-423-21	s	RES, CHIP NETWORK 47 (3216)
RB053	1-233-880-21	s	RES, NETWORK 68 (3216)
RB054	1-233-413-21	s	RES, CHIP NETWORK 2.2K (3216)
RB055	1-233-413-21	s	RES, CHIP NETWORK 2.2K (3216)
RB056	1-233-413-21	s	RES, CHIP NETWORK 2.2K (3216)
RB700	1-234-370-21	s	RES, NETWORK 22 (1005X4)
RB701	1-234-370-21	s	RES, NETWORK 22 (1005X4)
RB702	1-234-370-21	s	RES, NETWORK 22 (1005X4)
RB703	1-234-370-21	s	RES, NETWORK 22 (1005X4)
RB900	1-234-371-21	s	RES, NETWORK 47 (1005X4)
RB901	1-234-371-21	s	RES, NETWORK 47 (1005X4)
RB902	1-234-370-21	s	RES, NETWORK 22 (1005X4)
RB903	1-234-370-21	s	RES, NETWORK 22 (1005X4)
RB904	1-234-371-21	s	RES, NETWORK 47 (1005X4)
RB905	1-234-371-21	s	RES, NETWORK 47 (1005X4)
RB906	1-234-371-21	s	RES, NETWORK 47 (1005X4)
RB907	1-234-371-21	s	RES, NETWORK 47 (1005X4)

(BK BOARD)

Ref. No. or Q'ty	Part No.	SP Description
RB908	1-234-371-21	s RES, NETWORK 47 (1005X4)
RB909	1-234-371-21	s RES, NETWORK 47 (1005X4)
RB910	1-234-371-21	s RES, NETWORK 47 (1005X4)
RB911	1-234-371-21	s RES, NETWORK 47 (1005X4)
RB912	1-233-413-21	s RES, CHIP NETWORK 2.2K (3216)
S740	1-771-709-21	s SWITCH, SLIDE
TP001	1-535-877-22	s CHIP, CHECKER
TP002	1-535-877-22	s CHIP, CHECKER
TP003	1-535-877-22	s CHIP, CHECKER
TP004	1-535-877-22	s CHIP, CHECKER
TP005	1-535-877-22	s CHIP, CHECKER
TP006	1-535-877-22	s CHIP, CHECKER
TP007	1-535-877-22	s CHIP, CHECKER
TP008	1-535-877-22	s CHIP, CHECKER
TP009	1-535-877-22	s CHIP, CHECKER
TP010	1-535-877-22	s CHIP, CHECKER
TP011	1-535-757-21	s CHIP, CHECKER
TP012	1-535-877-22	s CHIP, CHECKER
TP040	1-535-757-21	s CHIP, CHECKER
TP041	1-535-757-21	s CHIP, CHECKER
TP042	1-535-877-22	s CHIP, CHECKER
TP100	1-535-757-21	s CHIP, CHECKER
TP101	1-535-757-21	s CHIP, CHECKER
TP120	1-535-757-21	s CHIP, CHECKER
TP121	1-535-877-22	s CHIP, CHECKER
TP150	1-535-757-21	s CHIP, CHECKER
TP200	1-535-757-21	s CHIP, CHECKER
TP300	1-535-757-21	s CHIP, CHECKER
TP301	1-535-757-21	s CHIP, CHECKER
TP320	1-535-757-21	s CHIP, CHECKER
TP321	1-535-877-22	s CHIP, CHECKER
TP350	1-535-757-21	s CHIP, CHECKER
TP400	1-535-757-21	s CHIP, CHECKER
TP500	1-535-757-21	s CHIP, CHECKER
TP501	1-535-757-21	s CHIP, CHECKER
TP520	1-535-757-21	s CHIP, CHECKER
TP521	1-535-877-22	s CHIP, CHECKER
TP550	1-535-757-21	s CHIP, CHECKER
TP600	1-535-757-21	s CHIP, CHECKER
TP601	1-535-757-21	s CHIP, CHECKER
TP602	1-535-877-22	s CHIP, CHECKER
TP650	1-535-757-21	s CHIP, CHECKER
TP651	1-535-757-21	s CHIP, CHECKER
TP800	1-535-877-22	s CHIP, CHECKER
TP801	1-535-877-22	s CHIP, CHECKER
TP802	1-535-877-22	s CHIP, CHECKER
TP1000	1-535-877-22	s CHIP, CHECKER
TP1001	1-535-877-22	s CHIP, CHECKER
TP1100	1-535-757-21	s CHIP, CHECKER
TP1300	1-535-757-21	s CHIP, CHECKER
TP1500	1-535-757-21	s CHIP, CHECKER
TP1900	1-535-757-21	s CHIP, CHECKER
TP1901	1-535-757-21	s CHIP, CHECKER
TP1902	1-535-757-21	s CHIP, CHECKER
X040	1-795-984-11	s OSCILLATOR, CRYSTAL
X740	1-795-984-11	s OSCILLATOR, CRYSTAL

CA BOARD

Ref. No. or Q'ty	Part No.	SP Description
1pc	A-1166-053-A	s MOUNTED CIRCUIT BOARD, CA
2pcs	3-648-057-00	o NUT (ISO-4), U
2pcs	7-682-566-04	s SCREW +B 4X20
7pcs	2-630-808-01	s SCREW, +PS3 (SUS) (CA-HEATSINK(4), HEATSINK ASSY(3))
18pcs	4-382-854-01	s SCREW (M3X8), P, SW (+) (IC704(1), Q103(1), Q105(1), Q106(1), Q303(1), Q305(1), Q306(1), Q503(1), Q505(1), Q506(1), R115(1), R315(1), R515(1), HEAT SINK(1), HEATSINK ASSY(4))
4pcs	7-682-647-09	s SCREW +PS 3X6 (SHIELD(4))
C101	1-111-244-91	s CAP, ELECT 47MF
C102	1-100-566-91	s CAP, CHIP CERAMIC 0.1MF B 1608
C103	1-100-566-91	s CAP, CHIP CERAMIC 0.1MF B 1608
C104	1-127-738-91	s CAP, CERAMIC 4700000PF B(3225)
C105	1-107-944-91	s CAP, ELECT 22MF
C106	1-162-970-91	s CAP, CERAMIC 10000PF B 1608
C107	1-104-760-91	s CAP, CERAMIC 47000PF B (2012)
C108	1-164-390-91	s CAP, CERAMIC 330PF CH 1608
C110	1-162-970-91	s CAP, CERAMIC 10000PF B 1608
C111	1-127-738-91	s CAP, CERAMIC 4700000PF B(3225)
C112	1-162-914-91	s CAP, CERAMIC 9.0PF CH 1608
C113	1-162-925-91	s CAP, CERAMIC 68PF CH 1608
C114	1-104-760-91	s CAP, CERAMIC 47000PF B (2012)
C115	1-104-760-91	s CAP, CERAMIC 47000PF B (2012)
C116	1-104-760-91	s CAP, CERAMIC 47000PF B (2012)
C117	1-100-566-91	s CAP, CHIP CERAMIC 0.1MF B 1608
C301	1-111-244-91	s CAP, ELECT 47MF
C302	1-100-566-91	s CAP, CHIP CERAMIC 0.1MF B 1608
C303	1-100-566-91	s CAP, CHIP CERAMIC 0.1MF B 1608
C304	1-127-738-91	s CAP, CERAMIC 4700000PF B(3225)
C305	1-107-944-91	s CAP, ELECT 22MF
C306	1-162-970-91	s CAP, CERAMIC 10000PF B 1608
C307	1-104-760-91	s CAP, CERAMIC 47000PF B (2012)
C308	1-164-390-91	s CAP, CERAMIC 330PF CH 1608
C310	1-162-970-91	s CAP, CERAMIC 10000PF B 1608
C311	1-127-738-91	s CAP, CERAMIC 4700000PF B(3225)
C312	1-162-914-91	s CAP, CERAMIC 9.0PF CH 1608
C313	1-162-925-91	s CAP, CERAMIC 68PF CH 1608
C314	1-104-760-91	s CAP, CERAMIC 47000PF B (2012)
C315	1-104-760-91	s CAP, CERAMIC 47000PF B (2012)
C316	1-104-760-91	s CAP, CERAMIC 47000PF B (2012)
C317	1-100-566-91	s CAP, CHIP CERAMIC 0.1MF B 1608
C501	1-111-244-91	s CAP, ELECT 47MF
C502	1-100-566-91	s CAP, CHIP CERAMIC 0.1MF B 1608
C503	1-100-566-91	s CAP, CHIP CERAMIC 0.1MF B 1608
C504	1-127-738-91	s CAP, CERAMIC 4700000PF B(3225)
C505	1-107-944-91	s CAP, ELECT 22MF
C506	1-162-970-91	s CAP, CERAMIC 10000PF B 1608
C507	1-104-760-91	s CAP, CERAMIC 47000PF B (2012)
C508	1-164-390-91	s CAP, CERAMIC 330PF CH 1608
C510	1-162-970-91	s CAP, CERAMIC 10000PF B 1608
C511	1-127-738-91	s CAP, CERAMIC 4700000PF B(3225)
C512	1-162-914-91	s CAP, CERAMIC 9.0PF CH 1608
C513	1-162-925-91	s CAP, CERAMIC 68PF CH 1608
C514	1-104-760-91	s CAP, CERAMIC 47000PF B (2012)
C515	1-104-760-91	s CAP, CERAMIC 47000PF B (2012)
C516	1-104-760-91	s CAP, CERAMIC 47000PF B (2012)
C517	1-100-566-91	s CAP, CHIP CERAMIC 0.1MF B 1608
C701	1-128-526-91	s CAP, ELECT 100MF
C702	1-100-566-91	s CAP, CHIP CERAMIC 0.1MF B 1608

(CA BOARD)

Ref. No. or Q'ty	Part No.	SP Description
C703	1-107-882-91	s CAP, ELECT 100MF
C704	1-100-566-91	s CAP, CHIP CERAMIC 0.1MF B 1608
C705	1-128-526-91	s CAP, ELECT 100MF
C706	1-100-566-91	s CAP, CHIP CERAMIC 0.1MF B 1608
C707	1-107-882-91	s CAP, ELECT 100MF
C708	1-100-566-91	s CAP, CHIP CERAMIC 0.1MF B 1608
C709	1-100-566-91	s CAP, CHIP CERAMIC 0.1MF B 1608
C710	1-100-566-91	s CAP, CHIP CERAMIC 0.1MF B 1608
C711	1-100-566-91	s CAP, CHIP CERAMIC 0.1MF B 1608
C712	1-107-943-91	s CAP, ELECT 10MF
C713	1-107-943-91	s CAP, ELECT 10MF
C714	1-107-364-91	s CAP, PETP FILM 0.01MF
C715	1-100-566-91	s CAP, CHIP CERAMIC 0.1MF B 1608
C716	1-107-882-91	s CAP, ELECT 100MF
C717	1-107-942-91	s CAP, ELECT 4.7MF
C718	1-107-943-91	s CAP, ELECT 10MF
C719	1-107-882-91	s CAP, ELECT 100MF
C720	1-100-566-91	s CAP, CHIP CERAMIC 0.1MF B 1608
C721	1-107-882-91	s CAP, ELECT 100MF
C722	1-100-566-91	s CAP, CHIP CERAMIC 0.1MF B 1608
C723	1-107-882-91	s CAP, ELECT 100MF
C724	1-100-566-91	s CAP, CHIP CERAMIC 0.1MF B 1608
CN101	1-564-507-71	o PLUG, CONNECTOR 4P
CN301	1-564-507-51	o PLUG, CONNECTOR 4P
CN501	1-564-507-61	o PLUG, CONNECTOR 4P
CN701	1-817-753-11	o CONNECTOR, BOARD TO BOARD 100P
CN702	1-564-509-51	o PLUG, CONNECTOR 6P
D101	8-719-404-50	s DIODE MA111-TX
D103	8-719-404-50	s DIODE MA111-TX
D104	8-719-404-50	s DIODE MA111-TX
D105	8-719-161-05	s DIODE RD8.2SB-T1
D106	8-719-404-50	s DIODE MA111-TX
D107	8-719-404-50	s DIODE MA111-TX
D108	8-719-074-48	s DIODE HSU83TRF
D109	8-719-074-48	s DIODE HSU83TRF
D301	8-719-404-50	s DIODE MA111-TX
D303	8-719-404-50	s DIODE MA111-TX
D304	8-719-404-50	s DIODE MA111-TX
D305	8-719-161-05	s DIODE RD8.2SB-T1
D306	8-719-404-50	s DIODE MA111-TX
D307	8-719-404-50	s DIODE MA111-TX
D308	8-719-074-48	s DIODE HSU83TRF
D309	8-719-074-48	s DIODE HSU83TRF
D501	8-719-404-50	s DIODE MA111-TX
D503	8-719-404-50	s DIODE MA111-TX
D504	8-719-404-50	s DIODE MA111-TX
D505	8-719-161-05	s DIODE RD8.2SB-T1
D506	8-719-404-50	s DIODE MA111-TX
D507	8-719-404-50	s DIODE MA111-TX
D508	8-719-074-48	s DIODE HSU83TRF
D509	8-719-074-48	s DIODE HSU83TRF
D701	8-719-037-22	s DIODE RD12SB-T1
D702	8-719-037-22	s DIODE RD12SB-T1
D703	8-719-063-74	s DIODE DINL20U-TR2
D704	8-719-404-50	s DIODE MA111-TX
D705	8-719-074-48	s DIODE HSU83TRF
D706	8-719-074-48	s DIODE HSU83TRF
D707	8-719-074-48	s DIODE HSU83TRF
D708	8-719-074-48	s DIODE HSU83TRF

(CA BOARD)

Ref. No. or Q'ty	Part No.	SP Description
F701	1-533-998-21	s FUSE, (SMD) (1A/125V)
F702	1-533-900-21	s FUSE (0.25A/125V)
F703	1-533-900-21	s FUSE (0.25A/125V)
F704	1-533-900-21	s FUSE (0.25A/125V)
F705	1-533-900-21	s FUSE (0.25A/125V)
IC101	8-759-332-59	s IC LT1252CS8-E2
IC301	8-759-332-59	s IC LT1252CS8-E2
IC501	8-759-332-59	s IC LT1252CS8-E2
IC701	6-702-295-01	s IC NJM78M12DL1A-TE1
IC702	8-759-276-28	s IC LM393PS-E20
IC703	8-759-539-89	s IC LM2990SX-5.0
IC704	6-707-184-01	s IC LM2426TE/NOPB
IC705	6-700-792-01	s IC NJM78M09DL1A (TE1)
IC706	6-700-792-01	s IC NJM78M09DL1A (TE1)
IC707	6-700-792-01	s IC NJM78M09DL1A (TE1)
L101	1-412-990-41	s INDUCTOR, SMALL TYPE 8.2UH
L301	1-412-990-41	s INDUCTOR, SMALL TYPE 8.2UH
L501	1-412-990-41	s INDUCTOR, SMALL TYPE 8.2UH
Q101	8-729-026-53	s TRANSISTOR 2SA1576A-T106-QR
Q102	8-729-809-23	s TRANSISTOR 2SC3950-E
Q103	8-729-019-70	s TRANSISTOR 2SC3955-DE
Q104	8-729-809-23	s TRANSISTOR 2SC3950-E
Q105	8-729-019-70	s TRANSISTOR 2SC3955-DE
Q106	8-729-823-07	s TRANSISTOR 2SA1540-DE
Q107	8-729-026-53	s TRANSISTOR 2SA1576A-T106-QR
Q108	8-729-019-95	s TRANSISTOR 2SK1589-L-T1B
Q109	8-729-112-85	s TRANSISTOR 2SA1330-T106
Q110	8-729-026-53	s TRANSISTOR 2SA1576A-T106-QR
Q111	8-729-026-53	s TRANSISTOR 2SA1576A-T106-QR
Q112	8-729-140-86	s TRANSISTOR 2SA1610-T1Y34
Q112	8-729-143-09	s TRANSISTOR 2SA1610-T1Y33
Q301	8-729-026-53	s TRANSISTOR 2SA1576A-T106-QR
Q302	8-729-809-23	s TRANSISTOR 2SC3950-E
Q303	8-729-019-70	s TRANSISTOR 2SC3955-DE
Q304	8-729-809-23	s TRANSISTOR 2SC3950-E
Q305	8-729-019-70	s TRANSISTOR 2SC3955-DE
Q306	8-729-823-07	s TRANSISTOR 2SA1540-DE
Q307	8-729-026-53	s TRANSISTOR 2SA1576A-T106-QR
Q308	8-729-019-95	s TRANSISTOR 2SK1589-L-T1B
Q309	8-729-112-85	s TRANSISTOR 2SA1330-T106
Q310	8-729-026-53	s TRANSISTOR 2SA1576A-T106-QR
Q311	8-729-026-53	s TRANSISTOR 2SA1576A-T106-QR
Q312	8-729-140-86	s TRANSISTOR 2SA1610-T1Y34
Q312	8-729-143-09	s TRANSISTOR 2SA1610-T1Y33
Q501	8-729-026-53	s TRANSISTOR 2SA1576A-T106-QR
Q502	8-729-809-23	s TRANSISTOR 2SC3950-E
Q503	8-729-019-70	s TRANSISTOR 2SC3955-DE
Q504	8-729-809-23	s TRANSISTOR 2SC3950-E
Q505	8-729-019-70	s TRANSISTOR 2SC3955-DE
Q506	8-729-823-07	s TRANSISTOR 2SA1540-DE
Q507	8-729-026-53	s TRANSISTOR 2SA1576A-T106-QR
Q508	8-729-019-95	s TRANSISTOR 2SK1589-L-T1B
Q509	8-729-112-85	s TRANSISTOR 2SA1330-T106
Q510	8-729-026-53	s TRANSISTOR 2SA1576A-T106-QR
Q511	8-729-026-53	s TRANSISTOR 2SA1576A-T106-QR
Q512	8-729-140-86	s TRANSISTOR 2SA1610-T1Y34
Q512	8-729-143-09	s TRANSISTOR 2SA1610-T1Y33
Q701	8-729-903-68	s TRANSISTOR 2SD982
Q702	8-729-026-53	s TRANSISTOR 2SA1576A-T106-QR

(CA BOARD)

Ref. No. or Q'ty	Part No.	SP	Description
R101	1-218-899-91	s RES,	CHIP 150K (1608)
R102	1-218-827-91	s RES,	CHIP 150 (1608)
R103	1-216-809-91	s RES,	CHIP 100 (1608)
R104	1-216-828-91	s RES,	CHIP 3.9K (1608)
R105	1-216-813-91	s RES,	CHIP 220 (1608)
R106	1-218-849-91	s RES,	CHIP 1.2K (1608)
R107	1-218-839-91	s RES,	CHIP 470 (1608)
R108	1-218-851-91	s RES,	CHIP 1.5K (1608)
R109	1-218-847-91	s RES,	CHIP 1.0K (1608)
R110	1-218-847-91	s RES,	CHIP 1.0K (1608)
R111	1-216-809-91	s RES,	CHIP 100 (1608)
R112	1-218-831-91	s RES,	CHIP 220 (1608)
R113	1-218-827-91	s RES,	CHIP 150 (1608)
R114	1-214-828-81	s RES,	METAL FILM 33
R115	1-245-948-11	s RES,	METAL FILM 1.8K
R116	1-218-827-91	s RES,	CHIP 150 (1608)
R117	1-211-981-91	s RES,	CHIP 33 (1608)
R118	1-216-801-91	s RES,	CHIP 22 (1608)
R119	1-216-801-91	s RES,	CHIP 22 (1608)
R120	1-215-863-71	s RES,	METAL OXIDE FILM 100
R121	1-216-799-91	s RES,	CHIP 15 (1608)
R122	1-216-799-91	s RES,	CHIP 15 (1608)
R123	1-215-863-71	s RES,	METAL OXIDE FILM 100
R124	1-216-853-91	s RES,	CHIP 470K (1608)
R125	1-218-887-91	s RES,	CHIP 47K (1608)
R126	1-218-887-91	s RES,	CHIP 47K (1608)
R127	1-218-887-91	s RES,	CHIP 47K (1608)
R128	1-218-887-91	s RES,	CHIP 47K (1608)
R129	1-218-865-91	s RES,	CHIP 5.6K (1608)
R130	1-216-830-91	s RES,	CHIP 5.6K (1608)
R131	1-216-809-91	s RES,	CHIP 100 (1608)
R132	1-216-847-91	s RES,	CHIP 150K (1608)
R133	1-216-847-91	s RES,	CHIP 150K (1608)
R134	1-216-847-91	s RES,	CHIP 150K (1608)
R135	1-216-847-91	s RES,	CHIP 150K (1608)
R136	1-216-847-91	s RES,	CHIP 150K (1608)
R137	1-216-847-91	s RES,	CHIP 150K (1608)
R138	1-249-409-91	s RES,	CARBON (SMALL) 220
R139	1-218-865-91	s RES,	CHIP 5.6K (1608)
R140	1-216-830-91	s RES,	CHIP 5.6K (1608)
R141	1-216-809-91	s RES,	CHIP 100 (1608)
R142	1-216-847-91	s RES,	CHIP 150K (1608)
R143	1-216-847-91	s RES,	CHIP 150K (1608)
R144	1-240-929-91	s RES,	(SURGE RESISTANT) 68
R145	1-211-989-91	s RES,	CHIP 68 (1608)
R146	1-211-989-91	s RES,	CHIP 68 (1608)
R147	1-214-824-81	s RES,	METAL FILM 22
R148	1-211-977-91	s RES,	CHIP 22 (1608)
R149	1-218-823-91	s RES,	CHIP 100 (1608)
R150	1-218-839-91	s RES,	CHIP 470 (1608)
R151	1-216-809-91	s RES,	CHIP 100 (1608)
R152	1-216-817-91	s RES,	CHIP 470 (1608)
R153	1-216-817-91	s RES,	CHIP 470 (1608)
R154	1-216-864-91	s CONDUCTOR,	CHIP (1608)
R301	1-218-899-91	s RES,	CHIP 150K (1608)
R302	1-218-827-91	s RES,	CHIP 150 (1608)
R303	1-216-809-91	s RES,	CHIP 100 (1608)
R304	1-216-828-91	s RES,	CHIP 3.9K (1608)
R305	1-216-813-91	s RES,	CHIP 220 (1608)
R306	1-218-849-91	s RES,	CHIP 1.2K (1608)

(CA BOARD)

Ref. No. or Q'ty	Part No.	SP	Description
R307	1-218-839-91	s RES,	CHIP 470 (1608)
R308	1-218-851-91	s RES,	CHIP 1.5K (1608)
R309	1-218-847-91	s RES,	CHIP 1.0K (1608)
R310	1-218-847-91	s RES,	CHIP 1.0K (1608)
R311	1-216-809-91	s RES,	CHIP 100 (1608)
R312	1-218-831-91	s RES,	CHIP 220 (1608)
R313	1-218-827-91	s RES,	CHIP 150 (1608)
R314	1-214-828-81	s RES,	METAL FILM 33
R315	1-245-948-11	s RES,	METAL FILM 1.8K
R316	1-218-827-91	s RES,	CHIP 150 (1608)
R317	1-211-981-91	s RES,	CHIP 33 (1608)
R318	1-216-801-91	s RES,	CHIP 22 (1608)
R319	1-216-801-91	s RES,	CHIP 22 (1608)
R320	1-215-863-71	s RES,	METAL OXIDE FILM 100
R321	1-216-799-91	s RES,	CHIP 15 (1608)
R322	1-216-799-91	s RES,	CHIP 15 (1608)
R323	1-215-863-71	s RES,	METAL OXIDE FILM 100
R324	1-216-853-91	s RES,	CHIP 470K (1608)
R325	1-218-887-91	s RES,	CHIP 47K (1608)
R326	1-218-887-91	s RES,	CHIP 47K (1608)
R327	1-218-887-91	s RES,	CHIP 47K (1608)
R328	1-218-887-91	s RES,	CHIP 47K (1608)
R329	1-218-865-91	s RES,	CHIP 5.6K (1608)
R330	1-216-830-91	s RES,	CHIP 5.6K (1608)
R331	1-216-809-91	s RES,	CHIP 100 (1608)
R332	1-216-847-91	s RES,	CHIP 150K (1608)
R333	1-216-847-91	s RES,	CHIP 150K (1608)
R334	1-216-847-91	s RES,	CHIP 150K (1608)
R335	1-216-847-91	s RES,	CHIP 150K (1608)
R336	1-216-847-91	s RES,	CHIP 150K (1608)
R337	1-216-847-91	s RES,	CHIP 150K (1608)
R338	1-249-409-91	s RES,	CARBON (SMALL) 220
R339	1-218-865-91	s RES,	CHIP 5.6K (1608)
R340	1-216-830-91	s RES,	CHIP 5.6K (1608)
R341	1-216-809-91	s RES,	CHIP 100 (1608)
R342	1-216-847-91	s RES,	CHIP 150K (1608)
R343	1-216-847-91	s RES,	CHIP 150K (1608)
R344	1-240-929-91	s RES,	(SURGE RESISTANT) 68
R345	1-211-989-91	s RES,	CHIP 68 (1608)
R346	1-211-989-91	s RES,	CHIP 68 (1608)
R347	1-214-824-81	s RES,	METAL FILM 22
R348	1-211-977-91	s RES,	CHIP 22 (1608)
R349	1-218-823-91	s RES,	CHIP 100 (1608)
R350	1-218-839-91	s RES,	CHIP 470 (1608)
R351	1-216-809-91	s RES,	CHIP 100 (1608)
R352	1-216-817-91	s RES,	CHIP 470 (1608)
R353	1-216-817-91	s RES,	CHIP 470 (1608)
R354	1-216-864-91	s CONDUCTOR,	CHIP (1608)
R501	1-218-899-91	s RES,	CHIP 150K (1608)
R502	1-218-827-91	s RES,	CHIP 150 (1608)
R503	1-216-809-91	s RES,	CHIP 100 (1608)
R504	1-216-828-91	s RES,	CHIP 3.9K (1608)
R505	1-216-813-91	s RES,	CHIP 220 (1608)
R506	1-218-849-91	s RES,	CHIP 1.2K (1608)
R507	1-218-839-91	s RES,	CHIP 470 (1608)
R508	1-218-851-91	s RES,	CHIP 1.5K (1608)
R509	1-218-847-91	s RES,	CHIP 1.0K (1608)
R510	1-218-847-91	s RES,	CHIP 1.0K (1608)
R511	1-216-809-91	s RES,	CHIP 100 (1608)
R512	1-218-831-91	s RES,	CHIP 220 (1608)

(CA BOARD)

Ref. No. or Q'ty	Part No.	SP Description
R513	1-218-827-91	s RES, CHIP 150 (1608)
R514	1-214-828-81	s RES, METAL FILM 33
R515	1-245-948-11	s RES, METAL FILM 1.8K
R516	1-218-827-91	s RES, CHIP 150 (1608)
R517	1-211-981-91	s RES, CHIP 33 (1608)
R518	1-216-801-91	s RES, CHIP 22 (1608)
R519	1-216-801-91	s RES, CHIP 22 (1608)
R520	1-215-863-71	s RES, METAL OXIDE FILM 100
R521	1-216-799-91	s RES, CHIP 15 (1608)
R522	1-216-799-91	s RES, CHIP 15 (1608)
R523	1-215-863-71	s RES, METAL OXIDE FILM 100
R524	1-216-853-91	s RES, CHIP 470K (1608)
R525	1-218-887-91	s RES, CHIP 47K (1608)
R526	1-218-887-91	s RES, CHIP 47K (1608)
R527	1-218-887-91	s RES, CHIP 47K (1608)
R528	1-218-887-91	s RES, CHIP 47K (1608)
R529	1-218-865-91	s RES, CHIP 5.6K (1608)
R530	1-216-830-91	s RES, CHIP 5.6K (1608)
R531	1-216-809-91	s RES, CHIP 100 (1608)
R532	1-216-847-91	s RES, CHIP 150K (1608)
R533	1-216-847-91	s RES, CHIP 150K (1608)
R534	1-216-847-91	s RES, CHIP 150K (1608)
R535	1-216-847-91	s RES, CHIP 150K (1608)
R536	1-216-847-91	s RES, CHIP 150K (1608)
R537	1-216-847-91	s RES, CHIP 150K (1608)
R538	1-249-409-91	s RES, CARBON (SMALL) 220
R539	1-218-865-91	s RES, CHIP 5.6K (1608)
R540	1-216-830-91	s RES, CHIP 5.6K (1608)
R541	1-216-809-91	s RES, CHIP 100 (1608)
R542	1-216-847-91	s RES, CHIP 150K (1608)
R543	1-216-847-91	s RES, CHIP 150K (1608)
R544	1-240-929-91	s RES, (SURGE RESISTANT) 68
R545	1-211-989-91	s RES, CHIP 68 (1608)
R546	1-211-989-91	s RES, CHIP 68 (1608)
R547	1-214-824-81	s RES, METAL FILM 22
R548	1-211-977-91	s RES, CHIP 22 (1608)
R549	1-218-823-91	s RES, CHIP 100 (1608)
R550	1-218-839-91	s RES, CHIP 470 (1608)
R551	1-216-809-91	s RES, CHIP 100 (1608)
R552	1-216-817-91	s RES, CHIP 470 (1608)
R553	1-216-817-91	s RES, CHIP 470 (1608)
R554	1-216-864-91	s CONDUCTOR, CHIP (1608)
R701	1-216-809-91	s RES, CHIP 100 (1608)
R707	1-249-383-91	s RES, CARBON (SMALL) 1.5
R708	1-218-891-91	s RES, CHIP 68K (1608)
R709	1-218-891-91	s RES, CHIP 68K (1608)
R710	1-218-891-91	s RES, CHIP 68K (1608)
R711	1-218-891-91	s RES, CHIP 68K (1608)
R712	1-218-871-91	s RES, CHIP 10K (1608)
R713	1-218-891-91	s RES, CHIP 68K (1608)
R714	1-218-891-91	s RES, CHIP 68K (1608)
R715	1-218-891-91	s RES, CHIP 68K (1608)
R716	1-218-891-91	s RES, CHIP 68K (1608)
R717	1-218-877-91	s RES, CHIP 18K (1608)
R718	1-216-864-91	s CONDUCTOR, CHIP (1608)
R719	1-216-833-91	s RES, CHIP 10K (1608)
R720	1-216-833-91	s RES, CHIP 10K (1608)
R721	1-218-883-91	s RES, CHIP 33K (1608)
R722	1-218-873-91	s RES, CHIP 12K (1608)
R723	1-249-429-91	s RES, CARBON (SMALL) 10K

(CA BOARD)

Ref. No. or Q'ty	Part No.	SP Description
R724	1-218-839-91	s RES, CHIP 470 (1608)
R725	1-218-823-91	s RES, CHIP 100 (1608)
R726	1-218-839-91	s RES, CHIP 470 (1608)
R727	1-218-855-91	s RES, CHIP 2.2K (1608)
R729	1-218-855-91	s RES, CHIP 2.2K (1608)
R730	1-216-850-91	s RES, CHIP 270K (1608)
R731	1-216-850-91	s RES, CHIP 270K (1608)
R732	1-216-851-91	s RES, CHIP 330K (1608)
R733	1-216-851-91	s RES, CHIP 330K (1608)
R734	1-216-851-91	s RES, CHIP 330K (1608)
R735	1-219-743-91	s RESISTOR (SURGE RESISTANT) 100
R736	1-219-743-91	s RESISTOR (SURGE RESISTANT) 100
R737	1-216-809-91	s RES, CHIP 100 (1608)
R738	1-216-829-91	s RES, CHIP 4.7K (1608)
TP101	1-535-877-22	s CHIP, CHECKER
TP102	1-535-877-22	s CHIP, CHECKER
TP301	1-535-877-22	s CHIP, CHECKER
TP302	1-535-877-22	s CHIP, CHECKER
TP303	1-535-877-22	s CHIP, CHECKER
TP501	1-535-877-22	s CHIP, CHECKER
TP502	1-535-877-22	s CHIP, CHECKER
TP701	1-535-877-22	s CHIP, CHECKER
TP702	1-535-877-22	s CHIP, CHECKER
TP703	1-535-877-22	s CHIP, CHECKER
TP704	1-535-877-22	s CHIP, CHECKER
TP705	1-535-877-22	s CHIP, CHECKER
TP706	1-535-877-22	s CHIP, CHECKER
TP707	1-535-877-22	s CHIP, CHECKER
TP708	1-535-877-22	s CHIP, CHECKER
TP709	1-535-877-22	s CHIP, CHECKER

 C BOARD

Ref. No. or Q'ty	Part No.	SP	Description
1pc	A-1091-223-A	s	MOUNTED CIRCUIT BOARD, C
1pc	△ 1-251-116-12	s	SOCKET, CRT
C1	1-104-574-91	s	CAP, CERAMIC 4700PF B
C2	1-128-526-91	s	CAP, ELECT 100MF
C3	1-115-349-51	s	CAP, CERAMIC 10000PF F
C4	1-107-906-91	s	CAP, ELECT 10MF
C5	1-104-574-91	s	CAP, CERAMIC 4700PF B
C6	1-107-906-91	s	CAP, ELECT 10MF
C7	1-115-349-51	s	CAP, CERAMIC 10000PF F
CN1	1-695-915-21	s	TAB (CONTACT)
CN2	1-564-507-71	o	PLUG, CONNECTOR 4P
CN3	1-564-507-51	o	PLUG, CONNECTOR 4P
CN4	1-564-509-51	o	PLUG, CONNECTOR 6P
CN5	1-508-786-23	o	PIN, CONNECTOR (5MM PITCH) 2P
CN6	1-564-508-81	o	PLUG, CONNECTOR 5P
CN7	1-766-241-11	o	PIN, CONNECTOR (PC BOARD) 3P
CN8	1-564-507-61	o	PLUG, CONNECTOR 4P
D1	8-719-979-61	s	DIODE EGP10GPKG23
D2	8-719-404-50	s	DIODE MA111-TX
D3	8-719-037-49	s	DIODE RD24SB-T1
L1	1-410-460-21	s	MICRO INDUCTOR 1.5UH
L2	1-410-460-21	s	MICRO INDUCTOR 1.5UH
L3	1-410-460-21	s	MICRO INDUCTOR 1.5UH
L4	1-412-529-41	s	MICRO INDUCTOR 22UH
L5	1-410-465-21	s	MICRO INDUCTOR 3.9UH
Q1	8-729-140-99	s	TRANSISTOR 2SB734-T-34
Q2	8-729-020-07	s	TRANSISTOR 2SC4686A(LBSONY)
R1	1-219-741-91	s	RESISTOR (SURGE RESISTANT) 10
R2	1-219-741-91	s	RESISTOR (SURGE RESISTANT) 10
R3	1-240-933-91	s	RES, (SURGE RESISTANT) 1.5K
R4	1-240-933-91	s	RES, (SURGE RESISTANT) 1.5K
R5	1-240-931-91	s	RES, (SURGE RESISTANT) 330
R6	1-240-931-91	s	RES, (SURGE RESISTANT) 330
R7	1-240-931-91	s	RES, (SURGE RESISTANT) 330
R8	1-249-426-91	s	RES, CARBON (SMALL) 5.6K
R9	1-219-513-91	s	RESISTOR (SURGE RESISTANT) 4.7M
R10	1-216-049-91	s	RES, CHIP 1.0K (2012)
R11	1-220-825-91	s	RES, (SURGE RESISTANT) 330K
R12	1-249-426-91	s	RES, CARBON (SMALL) 5.6K
R13	1-240-933-91	s	RES, (SURGE RESISTANT) 1.5K
R14	1-216-073-91	s	RES, CHIP 10K (2012)
R15	1-219-537-91	s	RESISTOR (SURGE RESISTANT) 3.3K
R17	1-219-741-91	s	RESISTOR (SURGE RESISTANT) 10
R18	1-245-947-11	s	RES, METAL FILM 30M
R19	1-240-929-91	s	RES, (SURGE RESISTANT) 68
RV1	1-223-410-21	s	RES, ADJ, METAL FILM 110M
SG1	1-519-422-21	s	GAP, SPARK
SG2	1-519-421-32	s	GAP, DISCHARGE
SG3	1-519-421-32	s	GAP, DISCHARGE
SG4	1-519-421-32	s	GAP, DISCHARGE
SG5	1-519-421-32	s	GAP, DISCHARGE
SG6	1-519-421-32	s	GAP, DISCHARGE
SG7	1-519-421-32	s	GAP, DISCHARGE
SG8	1-519-422-21	s	GAP, SPARK
SG9	1-519-421-32	s	GAP, DISCHARGE

(C BOARD)

Ref. No. or Q'ty	Part No.	SP	Description
TP1	1-535-877-22	s	CHIP, CHECKER
TP2	1-535-877-22	s	CHIP, CHECKER
TP3	1-535-877-22	s	CHIP, CHECKER
TP4	1-535-877-22	s	CHIP, CHECKER

EA BOARD

Ref. No. or Q'ty	Part No.	SP Description
1pc	A-1173-137-A	s MOUNTED CIRCUIT BOARD, EA
2pcs	7-682-647-09	s SCREW +PS 3X6 (PANEL BRACKET(2))
C100	1-100-566-91	s CAP, CHIP CERAMIC 0.1MF B 1608
C101	1-100-566-91	s CAP, CHIP CERAMIC 0.1MF B 1608
C102	1-100-566-91	s CAP, CHIP CERAMIC 0.1MF B 1608
C103	1-100-566-91	s CAP, CHIP CERAMIC 0.1MF B 1608
C104	1-100-566-91	s CAP, CHIP CERAMIC 0.1MF B 1608
C105	1-115-416-91	s CAP,CHIP CERAMIC1000PF CH 1608
C106	1-100-566-91	s CAP, CHIP CERAMIC 0.1MF B 1608
C107	1-128-360-21	s CAP, CHIP CELECT 220MF
C108	1-126-394-21	s CAP, CHIP ELECT 10MF (4X5.7)
C200	1-162-970-91	s CAP, CERAMIC 10000PF B 1608
C201	1-162-968-91	s CAP,CHIP CERAMIC 4700PF B 1608
C202	1-162-970-91	s CAP, CERAMIC 10000PF B 1608
C203	1-162-970-91	s CAP, CERAMIC 10000PF B 1608
C204	1-104-760-91	s CAP, CERAMIC 47000PF B (2012)
C205	1-162-970-91	s CAP, CERAMIC 10000PF B 1608
C206	1-162-970-91	s CAP, CERAMIC 10000PF B 1608
C207	1-164-227-91	s CAP,CERAMIC 22000PF B 1608
C210	1-162-970-91	s CAP, CERAMIC 10000PF B 1608
C211	1-100-566-91	s CAP, CHIP CERAMIC 0.1MF B 1608
C213	1-162-968-91	s CAP,CHIP CERAMIC 4700PF B 1608
C214	1-162-927-91	s CAP, CERAMIC 100PF CH 1608
C217	1-162-970-91	s CAP, CERAMIC 10000PF B 1608
C218	1-100-566-91	s CAP, CHIP CERAMIC 0.1MF B 1608
C219	1-162-970-91	s CAP, CERAMIC 10000PF B 1608
C220	1-162-970-91	s CAP, CERAMIC 10000PF B 1608
C221	1-126-391-21	s CAP, CHIP ELECT 47MF (5X5.7)
C222	1-162-970-91	s CAP, CERAMIC 10000PF B 1608
C223	1-162-970-91	s CAP, CERAMIC 10000PF B 1608
C224	1-162-970-91	s CAP, CERAMIC 10000PF B 1608
C225	1-162-970-91	s CAP, CERAMIC 10000PF B 1608
C226	1-162-970-91	s CAP, CERAMIC 10000PF B 1608
C227	1-100-566-91	s CAP, CHIP CERAMIC 0.1MF B 1608
C228	1-100-566-91	s CAP, CHIP CERAMIC 0.1MF B 1608
C229	1-100-566-91	s CAP, CHIP CERAMIC 0.1MF B 1608
C230	1-100-566-91	s CAP, CHIP CERAMIC 0.1MF B 1608
C231	1-162-970-91	s CAP, CERAMIC 10000PF B 1608
C233	1-165-884-91	s CAP, CERAMIC 2.2MF (1608)
C235	1-112-161-21	s CAP, CHIP ELECT 1000MF (10X10)
C236	1-164-230-91	s CAP,CERAMIC 220PF CH 1608
C237	1-126-396-21	s CAP, CHIP ELECT 47MF (6.3X5.7)
C238	1-162-970-91	s CAP, CERAMIC 10000PF B 1608
C239	1-115-412-91	s CAP,CHIP CERAMIC 680PF CH 1608
C240	1-164-492-91	s CAP, CERAMIC 150000PF B (2012)
C241	1-100-566-91	s CAP, CHIP CERAMIC 0.1MF B 1608
C242	1-126-412-21	s CAP, CHIP ELECT 220MF (4X5.7)
C243	1-162-970-91	s CAP, CERAMIC 10000PF B 1608
C244	1-126-391-21	s CAP, CHIP ELECT 47MF (5X5.7)
C246	1-162-970-91	s CAP, CERAMIC 10000PF B 1608
C247	1-100-566-91	s CAP, CHIP CERAMIC 0.1MF B 1608
C248	1-162-927-91	s CAP, CERAMIC 100PF CH 1608
C249	1-162-970-91	s CAP, CERAMIC 10000PF B 1608
C250	1-162-968-91	s CAP,CHIP CERAMIC 4700PF B 1608
C251	1-162-927-91	s CAP, CERAMIC 100PF CH 1608
C252	1-100-566-91	s CAP, CHIP CERAMIC 0.1MF B 1608
C253	1-126-391-21	s CAP, CHIP ELECT 47MF (5X5.7)
C254	1-107-823-91	s CAP, CERAMIC 470000PF B (2012)
C255	1-125-889-91	s CAP, CHIP CERAMIC 2.2MF B 2012

(EA BOARD)

Ref. No. or Q'ty	Part No.	SP Description
C256	1-100-566-91	s CAP, CHIP CERAMIC 0.1MF B 1608
C257	1-127-573-91	s CAP, CHIP CERAMIC 1MF B (2012)
C258	1-127-573-91	s CAP, CHIP CERAMIC 1MF B (2012)
C260	1-112-161-21	s CAP, CHIP ELECT 1000MF (10X10)
C261	1-162-970-91	s CAP, CERAMIC 10000PF B 1608
C304	1-162-970-91	s CAP, CERAMIC 10000PF B 1608
C305	1-100-566-91	s CAP, CHIP CERAMIC 0.1MF B 1608
C306	1-100-566-91	s CAP, CHIP CERAMIC 0.1MF B 1608
C307	1-100-566-91	s CAP, CHIP CERAMIC 0.1MF B 1608
C308	1-137-710-91	s CAP, CERAMIC 10MF B (2012)
C309	1-137-710-91	s CAP, CERAMIC 10MF B (2012)
C310	1-100-566-91	s CAP, CHIP CERAMIC 0.1MF B 1608
C311	1-100-566-91	s CAP, CHIP CERAMIC 0.1MF B 1608
C312	1-100-566-91	s CAP, CHIP CERAMIC 0.1MF B 1608
C314	1-131-661-21	s CAP, CHIP ELECT 100MF(6.3X5.7)
C316	1-162-970-91	s CAP, CERAMIC 10000PF B 1608
C317	1-100-566-91	s CAP, CHIP CERAMIC 0.1MF B 1608
C318	1-100-566-91	s CAP, CHIP CERAMIC 0.1MF B 1608
C319	1-162-970-91	s CAP, CERAMIC 10000PF B 1608
C320	1-162-970-91	s CAP, CERAMIC 10000PF B 1608
C322	1-162-970-91	s CAP, CERAMIC 10000PF B 1608
C323	1-162-970-91	s CAP, CERAMIC 10000PF B 1608
C324	1-162-970-91	s CAP, CERAMIC 10000PF B 1608
C325	1-162-970-91	s CAP, CERAMIC 10000PF B 1608
C326	1-162-970-91	s CAP, CERAMIC 10000PF B 1608
C327	1-162-970-91	s CAP, CERAMIC 10000PF B 1608
C329	1-162-970-91	s CAP, CERAMIC 10000PF B 1608
C330	1-100-566-91	s CAP, CHIP CERAMIC 0.1MF B 1608
C331	1-100-566-91	s CAP, CHIP CERAMIC 0.1MF B 1608
C332	1-100-566-91	s CAP, CHIP CERAMIC 0.1MF B 1608
C333	1-100-566-91	s CAP, CHIP CERAMIC 0.1MF B 1608
C334	1-100-566-91	s CAP, CHIP CERAMIC 0.1MF B 1608
C336	1-100-566-91	s CAP, CHIP CERAMIC 0.1MF B 1608
C337	1-100-566-91	s CAP, CHIP CERAMIC 0.1MF B 1608
C339	1-100-566-91	s CAP, CHIP CERAMIC 0.1MF B 1608
C340	1-100-566-91	s CAP, CHIP CERAMIC 0.1MF B 1608
C342	1-100-566-91	s CAP, CHIP CERAMIC 0.1MF B 1608
C343	1-100-566-91	s CAP, CHIP CERAMIC 0.1MF B 1608
C344	1-100-566-91	s CAP, CHIP CERAMIC 0.1MF B 1608
C345	1-104-609-21	s CAP, CHIP ELECT 100MF (4X5.7)
C346	1-131-661-21	s CAP, CHIP ELECT 100MF(6.3X5.7)
C347	1-100-566-91	s CAP, CHIP CERAMIC 0.1MF B 1608
C349	1-131-661-21	s CAP, CHIP ELECT 100MF(6.3X5.7)
C350	1-100-566-91	s CAP, CHIP CERAMIC 0.1MF B 1608
C400	1-162-970-91	s CAP, CERAMIC 10000PF B 1608
C401	1-131-661-21	s CAP, CHIP ELECT 100MF(6.3X5.7)
C402	1-162-970-91	s CAP, CERAMIC 10000PF B 1608
C403	1-162-970-91	s CAP, CERAMIC 10000PF B 1608
C404	1-131-661-21	s CAP, CHIP ELECT 100MF(6.3X5.7)
C405	1-107-826-91	s CAP, CHIP CERAMIC 100000PF B
C406	1-162-970-91	s CAP, CERAMIC 10000PF B 1608
C407	1-162-970-91	s CAP, CERAMIC 10000PF B 1608
C408	1-162-970-91	s CAP, CERAMIC 10000PF B 1608
C409	1-162-970-91	s CAP, CERAMIC 10000PF B 1608
C410	1-162-970-91	s CAP, CERAMIC 10000PF B 1608
C411	1-162-970-91	s CAP, CERAMIC 10000PF B 1608
C412	1-162-970-91	s CAP, CERAMIC 10000PF B 1608
C413	1-162-970-91	s CAP, CERAMIC 10000PF B 1608
C414	1-131-661-21	s CAP, CHIP ELECT 100MF(6.3X5.7)

(EA BOARD)

Ref. No. or Q'ty	Part No.	SP	Description
C415	1-162-970-91	s	CAP, CERAMIC 10000PF B 1608
C416	1-162-970-91	s	CAP, CERAMIC 10000PF B 1608
C417	1-162-970-91	s	CAP, CERAMIC 10000PF B 1608
C418	1-162-970-91	s	CAP, CERAMIC 10000PF B 1608
C419	1-162-970-91	s	CAP, CERAMIC 10000PF B 1608
C625	1-126-391-21	s	CAP, CHIP ELECT 47MF (5X5.7)
C626	1-162-970-91	s	CAP, CERAMIC 10000PF B 1608
C627	1-135-344-21	s	CAP, ELECT 270MF (10X8)
C628	1-135-344-21	s	CAP, ELECT 270MF (10X8)
C629	1-162-970-91	s	CAP, CERAMIC 10000PF B 1608
C630	1-164-315-91	s	CAP, CERAMIC 470PF CH (1608)
C631	1-162-925-91	s	CAP, CERAMIC 68PF CH 1608
C632	1-162-966-91	s	CAP, CERAMIC 2200PF B 1608
C633	1-162-966-91	s	CAP, CERAMIC 2200PF B 1608
C634	1-162-970-91	s	CAP, CERAMIC 10000PF B 1608
C635	1-162-923-91	s	CAP, CERAMIC 47PF CH 1608
C636	1-100-566-91	s	CAP, CHIP CERAMIC 0.1MF B 1608
C637	1-125-889-91	s	CAP, CHIP CERAMIC 2.2MF B 2012
C638	1-162-970-91	s	CAP, CERAMIC 10000PF B 1608
C639	1-162-925-91	s	CAP, CERAMIC 68PF CH 1608
C640	1-164-315-91	s	CAP, CERAMIC 470PF CH (1608)
C641	1-137-894-21	s	CAP, ELECT (CHIP TYPE) 470MF
C642	1-162-966-91	s	CAP, CERAMIC 2200PF B 1608
C643	1-162-966-91	s	CAP, CERAMIC 2200PF B 1608
C644	1-164-315-91	s	CAP, CERAMIC 470PF CH (1608)
C645	1-100-566-91	s	CAP, CHIP CERAMIC 0.1MF B 1608
C646	1-100-566-91	s	CAP, CHIP CERAMIC 0.1MF B 1608
C647	1-100-566-91	s	CAP, CHIP CERAMIC 0.1MF B 1608
C648	1-100-566-91	s	CAP, CHIP CERAMIC 0.1MF B 1608
C649	1-162-970-91	s	CAP, CERAMIC 10000PF B 1608
C650	1-127-820-91	s	CAP, CHIP CERAMIC 4.7MF B 3216
C651	1-127-692-91	s	CAP, CHIP CERAMIC 10MF B 3225
C652	1-127-692-91	s	CAP, CHIP CERAMIC 10MF B 3225
C653	1-127-692-91	s	CAP, CHIP CERAMIC 10MF B 3225
C655	1-165-667-21	s	CAP, ELECT 100MF
C656	1-165-668-21	s	CAP, ELECT 150MF
C657	1-162-970-91	s	CAP, CERAMIC 10000PF B 1608
C658	1-162-970-91	s	CAP, CERAMIC 10000PF B 1608
C700	1-128-536-21	s	CAP, CHIP ELECT 100MF
C701	1-131-661-21	s	CAP, CHIP ELECT 100MF(6.3X5.7)
C702	1-131-661-21	s	CAP, CHIP ELECT 100MF(6.3X5.7)
C703	1-164-230-91	s	CAP, CERAMIC 220PF CH 1608
C704	1-100-566-91	s	CAP, CHIP CERAMIC 0.1MF B 1608
C705	1-100-566-91	s	CAP, CHIP CERAMIC 0.1MF B 1608
C706	1-128-536-21	s	CAP, CHIP ELECT 100MF
C707	1-100-566-91	s	CAP, CHIP CERAMIC 0.1MF B 1608
C708	1-100-566-91	s	CAP, CHIP CERAMIC 0.1MF B 1608
C709	1-126-396-21	s	CAP, CHIP ELECT 47MF (6.3X5.7)
C710	1-126-396-21	s	CAP, CHIP ELECT 47MF (6.3X5.7)
C711	1-131-661-21	s	CAP, CHIP ELECT 100MF(6.3X5.7)
C712	1-100-566-91	s	CAP, CHIP CERAMIC 0.1MF B 1608
C713	1-131-661-21	s	CAP, CHIP ELECT 100MF(6.3X5.7)
C714	1-100-566-91	s	CAP, CHIP CERAMIC 0.1MF B 1608
C715	1-100-566-91	s	CAP, CHIP CERAMIC 0.1MF B 1608
C716	1-131-661-21	s	CAP, CHIP ELECT 100MF(6.3X5.7)
C717	1-100-566-91	s	CAP, CHIP CERAMIC 0.1MF B 1608
C718	1-162-970-91	s	CAP, CERAMIC 10000PF B 1608
C719	1-100-566-91	s	CAP, CHIP CERAMIC 0.1MF B 1608
C720	1-131-661-21	s	CAP, CHIP ELECT 100MF(6.3X5.7)

(EA BOARD)

Ref. No. or Q'ty	Part No.	SP	Description
C721	1-162-970-91	s	CAP, CERAMIC 10000PF B 1608
C722	1-100-566-91	s	CAP, CHIP CERAMIC 0.1MF B 1608
C723	1-100-566-91	s	CAP, CHIP CERAMIC 0.1MF B 1608
C724	1-100-566-91	s	CAP, CHIP CERAMIC 0.1MF B 1608
C725	1-100-566-91	s	CAP, CHIP CERAMIC 0.1MF B 1608
C726	1-100-566-91	s	CAP, CHIP CERAMIC 0.1MF B 1608
C727	1-100-566-91	s	CAP, CHIP CERAMIC 0.1MF B 1608
C728	1-100-566-91	s	CAP, CHIP CERAMIC 0.1MF B 1608
C729	1-100-566-91	s	CAP, CHIP CERAMIC 0.1MF B 1608
C731	1-100-566-91	s	CAP, CHIP CERAMIC 0.1MF B 1608
C732	1-100-566-91	s	CAP, CHIP CERAMIC 0.1MF B 1608
C733	1-131-661-21	s	CAP, CHIP ELECT 100MF(6.3X5.7)
C734	1-162-970-91	s	CAP, CERAMIC 10000PF B 1608
CN400	1-764-080-21	o	PIN, CONNECTOR (PC BOARD) 8P
CN700	1-817-753-11	o	CONNECTOR, BOARD TO BOARD 100P
CN701	1-817-753-11	o	CONNECTOR, BOARD TO BOARD 100P
CN702	1-764-082-21	s	PIN, CONNECTOR (PC BOARD) 11P
D100	8-719-404-50	s	DIODE MA111-TX
D101	8-719-404-50	s	DIODE MA111-TX
D200	8-719-027-76	s	DIODE 1SS357-TPH3
D203	8-719-404-50	s	DIODE MA111-TX
D204	8-719-404-50	s	DIODE MA111-TX
D400	8-719-064-52	s	DIODE CL-191YG-CD-T
D600	8-719-404-50	s	DIODE MA111-TX
D601	8-719-404-50	s	DIODE MA111-TX
D602	8-719-404-50	s	DIODE MA111-TX
D604	8-719-027-76	s	DIODE 1SS357-TPH3
D605	8-719-027-76	s	DIODE 1SS357-TPH3
D606	8-719-073-92	s	DIODE RB060L-40TE25
D607	8-719-073-92	s	DIODE RB060L-40TE25
D700	8-719-064-52	s	DIODE CL-191YG-CD-T
F600	1-533-804-21	s	FUSE (SMD) (2.5A/125V)
F601	1-533-804-21	s	FUSE (SMD) (2.5A/125V)
F602	1-533-804-21	s	FUSE (SMD) (2.5A/125V)
FB700	1-500-448-21	s	FERRITE, EMI (SMD) (3216)
FB701	1-500-448-21	s	FERRITE, EMI (SMD) (3216)
FB702	1-500-448-21	s	FERRITE, EMI (SMD) (3216)
FB703	1-500-448-21	s	FERRITE, EMI (SMD) (3216)
FB704	1-500-448-21	s	FERRITE, EMI (SMD) (3216)
FB705	1-500-448-21	s	FERRITE, EMI (SMD) (3216)
IC100	8-759-523-84	s	IC TC74VHC14FT(EL)
IC101	8-759-490-41	s	IC TC74VHCT541AFT(EL)
IC102	8-759-523-84	s	IC TC74VHC14FT(EL)
IC103	8-759-491-46	s	IC TC74VHCT04AFT(EL)
IC104	8-759-491-46	s	IC TC74VHCT04AFT(EL)
IC105	8-759-523-97	s	IC TC74VHC123AFT(EL)
IC200	8-759-157-42	s	IC TL082CPS-E20
IC201	8-759-157-42	s	IC TL082CPS-E20
IC203	8-759-564-49	s	IC TC7W53FU(TE12R)
IC204	8-759-157-42	s	IC TL082CPS-E20
IC206	8-759-157-42	s	IC TL082CPS-E20
IC208	6-707-832-01	s	IC CXD9563Q-A
IC302	6-704-006-01	s	IC BR24L64F-WE2
IC303	6-708-748-01	s	IC BD4828FVE-TR
IC304	6-708-748-01	s	IC BD4828FVE-TR
IC306	6-706-488-01	s	IC TC7SH14FU(T5RSOYJF)
IC307	6-706-488-01	s	IC TC7SH14FU(T5RSOYJF)

(EA BOARD)

Ref. No. or Q'ty	Part No.	SP Description
IC308	6-700-387-01	s IC EPC2LC20N-TP
IC310	6-706-489-01	s IC TC7SH32FU (T5RSOYJF)
IC311	6-706-489-01	s IC TC7SH32FU (T5RSOYJF)
IC312	8-759-669-30	s IC TC74VHC05FT (EL)
IC313	6-705-027-01	s IC BD4840FVE-TR
IC400	6-709-436-01	s IC LC4128V-5TN100CA1353
IC401	8-759-592-46	s IC TC7SZ05FU (TE85R)
IC402	8-759-679-54	s IC SN74LVC14APWR
IC403	8-759-679-54	s IC SN74LVC14APWR
IC404	8-759-573-97	s IC SN74LVC541APWR
IC405	8-759-679-54	s IC SN74LVC14APWR
IC406	8-759-592-49	s IC TC7SZ125FU (TE85R)
IC611	6-702-510-01	s IC TPS5120DBTRG4
IC700	6-702-295-01	s IC NJM78M12DL1A-TE1
IC701	8-759-539-89	s IC LM2990SX-5.0
IC702	6-702-297-01	s IC NJM79M12DL1A-TE1
IC703	6-705-469-01	s IC BA50BC0FP-E2
IC704	8-759-523-84	s IC TC74VHC14FT (EL)
IC705	8-759-523-84	s IC TC74VHC14FT (EL)
IC706	6-705-468-01	s IC BA33BC0FP-E2
IC707	8-759-523-84	s IC TC74VHC14FT (EL)
IC708	8-759-523-84	s IC TC74VHC14FT (EL)
IC709	8-759-592-46	s IC TC7SZ05FU (TE85R)
IC710	8-759-490-41	s IC TC74VHCT541AFT (EL)
IC711	8-759-476-80	s IC LM75CIMX-3
IC712	8-759-523-84	s IC TC74VHC14FT (EL)
IC713	8-759-669-50	s IC SN74CBTD3306PWR-12
IC714	8-759-688-12	s IC TC74VHCT125AFT (EL)
IC715	8-759-276-28	s IC LM393PS-E20
L200	1-469-553-21	s INDUCTOR, CHIP 4.7UH (LB2016)
L201	1-416-928-21	s COIL, CHOKE (SMD) 470UH
L202	1-469-553-21	s INDUCTOR, CHIP 4.7UH (LB2016)
L203	1-469-553-21	s INDUCTOR, CHIP 4.7UH (LB2016)
L301	1-412-955-21	s INDUCTOR, SMALL TYPE 22UH 2520
L400	1-412-955-21	s INDUCTOR, SMALL TYPE 22UH 2520
L600	1-469-848-21	s INDUCTOR (SMD)
L601	1-469-848-21	s INDUCTOR (SMD)
L602	1-469-848-21	s INDUCTOR (SMD)
L603	1-469-848-21	s INDUCTOR (SMD)
Q100	8-729-028-91	s TRANSISTOR DTA144EUA-T106
Q101	8-729-028-91	s TRANSISTOR DTA144EUA-T106
Q102	8-729-028-91	s TRANSISTOR DTA144EUA-T106
Q103	8-729-028-91	s TRANSISTOR DTA144EUA-T106
Q104	8-729-029-14	s TRANSISTOR DTC144EUA-T106
Q105	8-729-029-14	s TRANSISTOR DTC144EUA-T106
Q106	8-729-029-04	s TRANSISTOR DTC123JUA-T106
Q107	8-729-028-81	s TRANSISTOR DTA123JUA-T106
Q108	8-729-029-04	s TRANSISTOR DTC123JUA-T106
Q109	8-729-029-14	s TRANSISTOR DTC144EUA-T106
Q200	8-729-905-38	s TRANSISTOR 2SC4081T106R
Q201	8-729-026-53	s TRANSISTOR 2SA1576A-T106-QR
Q202	8-729-905-38	s TRANSISTOR 2SC4081T106R
Q203	8-729-019-85	s TRANSISTOR 2SC3392-5-TB-E
Q204	8-729-824-24	s TRANSISTOR 2SA1338-5-TB-E
Q205	8-729-028-91	s TRANSISTOR DTA144EUA-T106
Q206	8-729-029-14	s TRANSISTOR DTC144EUA-T106
Q207	8-729-029-04	s TRANSISTOR DTC123JUA-T106
Q208	8-729-905-38	s TRANSISTOR 2SC4081T106R
Q209	8-729-029-04	s TRANSISTOR DTC123JUA-T106

(EA BOARD)

Ref. No. or Q'ty	Part No.	SP Description
Q603	8-729-026-53	s TRANSISTOR 2SA1576A-T106-QR
Q605	8-729-029-14	s TRANSISTOR DTC144EUA-T106
Q606	8-729-029-14	s TRANSISTOR DTC144EUA-T106
Q607	8-729-028-81	s TRANSISTOR DTA123JUA-T106
Q608	8-729-029-14	s TRANSISTOR DTC144EUA-T106
Q609	6-550-374-01	s TRANSISTOR TPC8009-H (T2LSONYF)
Q612	6-550-374-01	s TRANSISTOR TPC8009-H (T2LSONYF)
Q613	6-550-374-01	s TRANSISTOR TPC8009-H (T2LSONYF)
Q615	6-550-374-01	s TRANSISTOR TPC8009-H (T2LSONYF)
Q617	8-729-028-91	s TRANSISTOR DTA144EUA-T106
Q618	8-729-029-14	s TRANSISTOR DTC144EUA-T106
Q700	8-729-028-91	s TRANSISTOR DTA144EUA-T106
Q701	8-729-028-91	s TRANSISTOR DTA144EUA-T106
Q702	8-729-028-91	s TRANSISTOR DTA144EUA-T106
Q703	8-729-028-91	s TRANSISTOR DTA144EUA-T106
Q704	8-729-028-91	s TRANSISTOR DTA144EUA-T106
Q705	8-729-028-91	s TRANSISTOR DTA144EUA-T106
Q708	8-729-028-91	s TRANSISTOR DTA144EUA-T106
Q709	8-729-028-91	s TRANSISTOR DTA144EUA-T106
Q710	8-729-028-91	s TRANSISTOR DTA144EUA-T106
R100	1-216-813-91	s RES, CHIP 220 (1608)
R101	1-216-813-91	s RES, CHIP 220 (1608)
R102	1-216-813-91	s RES, CHIP 220 (1608)
R103	1-216-809-91	s RES, CHIP 100 (1608)
R104	1-216-813-91	s RES, CHIP 220 (1608)
R105	1-216-813-91	s RES, CHIP 220 (1608)
R106	1-216-813-91	s RES, CHIP 220 (1608)
R107	1-216-813-91	s RES, CHIP 220 (1608)
R108	1-216-813-91	s RES, CHIP 220 (1608)
R109	1-216-813-91	s RES, CHIP 220 (1608)
R110	1-216-833-91	s RES, CHIP 10K (1608)
R111	1-216-833-91	s RES, CHIP 10K (1608)
R112	1-216-813-91	s RES, CHIP 220 (1608)
R113	1-216-833-91	s RES, CHIP 10K (1608)
R114	1-216-845-91	s RES, CHIP 100K (1608)
R115	1-216-833-91	s RES, CHIP 10K (1608)
R116	1-216-813-91	s RES, CHIP 220 (1608)
R117	1-216-833-91	s RES, CHIP 10K (1608)
R118	1-216-813-91	s RES, CHIP 220 (1608)
R119	1-216-813-91	s RES, CHIP 220 (1608)
R120	1-216-813-91	s RES, CHIP 220 (1608)
R121	1-216-833-91	s RES, CHIP 10K (1608)
R122	1-216-845-91	s RES, CHIP 100K (1608)
R123	1-216-833-91	s RES, CHIP 10K (1608)
R124	1-216-833-91	s RES, CHIP 10K (1608)
R125	1-216-845-91	s RES, CHIP 100K (1608)
R126	1-216-845-91	s RES, CHIP 100K (1608)
R127	1-216-845-91	s RES, CHIP 100K (1608)
R128	1-216-833-91	s RES, CHIP 10K (1608)
R129	1-216-813-91	s RES, CHIP 220 (1608)
R130	1-216-813-91	s RES, CHIP 220 (1608)
R131	1-216-813-91	s RES, CHIP 220 (1608)
R132	1-216-813-91	s RES, CHIP 220 (1608)
R133	1-216-813-91	s RES, CHIP 220 (1608)
R134	1-216-813-91	s RES, CHIP 220 (1608)
R135	1-216-813-91	s RES, CHIP 220 (1608)
R136	1-216-813-91	s RES, CHIP 220 (1608)
R137	1-216-813-91	s RES, CHIP 220 (1608)
R138	1-216-813-91	s RES, CHIP 220 (1608)

(EA BOARD)

Ref. No. or Q'ty	Part No.	SP	Description
R139	1-216-813-91	s RES,	CHIP 220 (1608)
R140	1-216-813-91	s RES,	CHIP 220 (1608)
R141	1-216-813-91	s RES,	CHIP 220 (1608)
R142	1-216-833-91	s RES,	CHIP 10K (1608)
R143	1-216-845-91	s RES,	CHIP 100K (1608)
R144	1-216-845-91	s RES,	CHIP 100K (1608)
R145	1-216-845-91	s RES,	CHIP 100K (1608)
R146	1-216-813-91	s RES,	CHIP 220 (1608)
R147	1-216-813-91	s RES,	CHIP 220 (1608)
R148	1-216-845-91	s RES,	CHIP 100K (1608)
R149	1-216-845-91	s RES,	CHIP 100K (1608)
R150	1-216-813-91	s RES,	CHIP 220 (1608)
R151	1-216-813-91	s RES,	CHIP 220 (1608)
R152	1-216-813-91	s RES,	CHIP 220 (1608)
R153	1-216-833-91	s RES,	CHIP 10K (1608)
R155	1-218-872-91	s RES,	CHIP 11K (1608)
R156	1-216-833-91	s RES,	CHIP 10K (1608)
R157	1-216-833-91	s RES,	CHIP 10K (1608)
R158	1-216-827-91	s RES,	CHIP 3.3K (1608)
R159	1-216-822-91	s RES,	CHIP 1.2K (1608)
R161	1-216-833-91	s RES,	CHIP 10K (1608)
R162	1-216-809-91	s RES,	CHIP 100 (1608)
R163	1-216-825-91	s RES,	CHIP 2.2K (1608)
R164	1-216-809-91	s RES,	CHIP 100 (1608)
R200	1-218-871-91	s RES,	CHIP 10K (1608)
R201	1-218-871-91	s RES,	CHIP 10K (1608)
R202	1-216-821-91	s RES,	CHIP 1.0K (1608)
R203	1-218-863-91	s RES,	CHIP 4.7K (1608)
R204	1-218-887-91	s RES,	CHIP 47K (1608)
R205	1-218-887-91	s RES,	CHIP 47K (1608)
R206	1-218-871-91	s RES,	CHIP 10K (1608)
R207	1-216-821-91	s RES,	CHIP 1.0K (1608)
R208	1-216-829-91	s RES,	CHIP 4.7K (1608)
R211	1-216-821-91	s RES,	CHIP 1.0K (1608)
R212	1-216-809-91	s RES,	CHIP 100 (1608)
R213	1-216-829-91	s RES,	CHIP 4.7K (1608)
R218	1-216-833-91	s RES,	CHIP 10K (1608)
R219	1-218-847-91	s RES,	CHIP 1.0K (1608)
R220	1-216-833-91	s RES,	CHIP 10K (1608)
R221	1-216-833-91	s RES,	CHIP 10K (1608)
R224	1-218-887-91	s RES,	CHIP 47K (1608)
R225	1-216-864-91	s CONDUCTOR,	CHIP (1608)
R226	1-218-871-91	s RES,	CHIP 10K (1608)
R227	1-216-864-91	s CONDUCTOR,	CHIP (1608)
R228	1-218-877-91	s RES,	CHIP 18K (1608)
R229	1-216-821-91	s RES,	CHIP 1.0K (1608)
R230	1-216-864-91	s CONDUCTOR,	CHIP (1608)
R231	1-216-864-91	s CONDUCTOR,	CHIP (1608)
R232	1-218-861-91	s RES,	CHIP 3.9K (1608)
R233	1-216-821-91	s RES,	CHIP 1.0K (1608)
R234	1-216-864-91	s CONDUCTOR,	CHIP (1608)
R235	1-216-821-91	s RES,	CHIP 1.0K (1608)
R238	1-218-887-91	s RES,	CHIP 47K (1608)
R239	1-218-851-91	s RES,	CHIP 1.5K (1608)
R241	1-218-859-91	s RES,	CHIP 3.3K (1608)
R242	1-216-821-91	s RES,	CHIP 1.0K (1608)
R243	1-216-809-91	s RES,	CHIP 100 (1608)
R245	1-216-809-91	s RES,	CHIP 100 (1608)
R247	1-216-809-91	s RES,	CHIP 100 (1608)

(EA BOARD)

Ref. No. or Q'ty	Part No.	SP	Description
R248	1-216-809-91	s RES,	CHIP 100 (1608)
R249	1-216-821-91	s RES,	CHIP 1.0K (1608)
R250	1-216-821-91	s RES,	CHIP 1.0K (1608)
R251	1-216-821-91	s RES,	CHIP 1.0K (1608)
R252	1-216-821-91	s RES,	CHIP 1.0K (1608)
R253	1-216-821-91	s RES,	CHIP 1.0K (1608)
R257	1-216-821-91	s RES,	CHIP 1.0K (1608)
R258	1-216-821-91	s RES,	CHIP 1.0K (1608)
R259	1-216-821-91	s RES,	CHIP 1.0K (1608)
R260	1-216-821-91	s RES,	CHIP 1.0K (1608)
R261	1-216-809-91	s RES,	CHIP 100 (1608)
R262	1-216-809-91	s RES,	CHIP 100 (1608)
R263	1-216-849-91	s RES,	CHIP 220K (1608)
R264	1-218-901-91	s RES,	CHIP 180K (1608)
R265	1-218-879-91	s RES,	CHIP 22K (1608)
R267	1-216-833-91	s RES,	CHIP 10K (1608)
R268	1-216-833-91	s RES,	CHIP 10K (1608)
R270	1-216-857-91	s RES,	CHIP 1.0M (1608)
R271	1-216-837-91	s RES,	CHIP 22K (1608)
R272	1-218-852-91	s RES,	CHIP 1.6K (1608)
R273	1-218-839-91	s RES,	CHIP 470 (1608)
R275	1-216-825-91	s RES,	CHIP 2.2K (1608)
R276	1-218-858-91	s RES,	CHIP 3.0K (1608)
R277	1-218-855-91	s RES,	CHIP 2.2K (1608)
R278	1-218-838-91	s RES,	CHIP 430 (1608)
R279	1-218-871-91	s RES,	CHIP 10K (1608)
R280	1-216-857-91	s RES,	CHIP 1.0M (1608)
R282	1-216-809-91	s RES,	CHIP 100 (1608)
R283	1-216-829-91	s RES,	CHIP 4.7K (1608)
R284	1-218-887-91	s RES,	CHIP 47K (1608)
R285	1-218-869-91	s RES,	CHIP 8.2K (1608)
R287	1-216-813-91	s RES,	CHIP 220 (1608)
R289	1-216-857-91	s RES,	CHIP 1.0M (1608)
R290	1-216-805-91	s RES,	CHIP 47 (1608)
R292	1-216-809-91	s RES,	CHIP 100 (1608)
R294	1-216-833-91	s RES,	CHIP 10K (1608)
R295	1-216-837-91	s RES,	CHIP 22K (1608)
R296	1-216-825-91	s RES,	CHIP 2.2K (1608)
R301	1-216-813-91	s RES,	CHIP 220 (1608)
R302	1-216-833-91	s RES,	CHIP 10K (1608)
R303	1-216-833-91	s RES,	CHIP 10K (1608)
R304	1-216-833-91	s RES,	CHIP 10K (1608)
R305	1-216-833-91	s RES,	CHIP 10K (1608)
R307	1-216-797-91	s RES,	CHIP 10 (1608)
R308	1-216-815-91	s RES,	CHIP 330 (1608)
R309	1-216-815-91	s RES,	CHIP 330 (1608)
R310	1-216-815-91	s RES,	CHIP 330 (1608)
R311	1-216-829-91	s RES,	CHIP 4.7K (1608)
R312	1-216-829-91	s RES,	CHIP 4.7K (1608)
R313	1-216-845-91	s RES,	CHIP 100K (1608)
R314	1-216-829-91	s RES,	CHIP 4.7K (1608)
R315	1-216-829-91	s RES,	CHIP 4.7K (1608)
R323	1-216-833-91	s RES,	CHIP 10K (1608)
R325	1-216-833-91	s RES,	CHIP 10K (1608)
R400	1-216-829-91	s RES,	CHIP 4.7K (1608)
R403	1-216-864-91	s CONDUCTOR,	CHIP (1608)
R404	1-216-829-91	s RES,	CHIP 4.7K (1608)
R407	1-216-864-91	s CONDUCTOR,	CHIP (1608)
R409	1-216-864-91	s CONDUCTOR,	CHIP (1608)

(EA BOARD)

Ref. No. or Q'ty	Part No.	SP Description
R410	1-216-829-91	s RES, CHIP 4.7K (1608)
R413	1-216-829-91	s RES, CHIP 4.7K (1608)
R415	1-216-829-91	s RES, CHIP 4.7K (1608)
R417	1-216-801-91	s RES, CHIP 22 (1608)
R418	1-216-801-91	s RES, CHIP 22 (1608)
R419	1-216-797-91	s RES, CHIP 10 (1608)
R420	1-216-801-91	s RES, CHIP 22 (1608)
R421	1-216-801-91	s RES, CHIP 22 (1608)
R422	1-216-801-91	s RES, CHIP 22 (1608)
R423	1-216-825-91	s RES, CHIP 2.2K (1608)
R424	1-216-807-91	s RES, CHIP 68 (1608)
R425	1-216-807-91	s RES, CHIP 68 (1608)
R426	1-216-807-91	s RES, CHIP 68 (1608)
R427	1-216-807-91	s RES, CHIP 68 (1608)
R428	1-216-807-91	s RES, CHIP 68 (1608)
R429	1-216-807-91	s RES, CHIP 68 (1608)
R430	1-216-807-91	s RES, CHIP 68 (1608)
R431	1-216-807-91	s RES, CHIP 68 (1608)
R432	1-216-801-91	s RES, CHIP 22 (1608)
R433	1-216-809-91	s RES, CHIP 100 (1608)
R434	1-216-801-91	s RES, CHIP 22 (1608)
R435	1-216-807-91	s RES, CHIP 68 (1608)
R436	1-216-807-91	s RES, CHIP 68 (1608)
R437	1-216-801-91	s RES, CHIP 22 (1608)
R438	1-216-807-91	s RES, CHIP 68 (1608)
R439	1-216-801-91	s RES, CHIP 22 (1608)
R440	1-216-837-91	s RES, CHIP 22K (1608)
R441	1-216-809-91	s RES, CHIP 100 (1608)
R442	1-216-837-91	s RES, CHIP 22K (1608)
R443	1-216-837-91	s RES, CHIP 22K (1608)
R444	1-216-837-91	s RES, CHIP 22K (1608)
R445	1-216-833-91	s RES, CHIP 10K (1608)
R446	1-216-837-91	s RES, CHIP 22K (1608)
R613	1-218-833-91	s RES, CHIP 270 (1608)
R614	1-218-865-91	s RES, CHIP 5.6K (1608)
R616	1-218-871-91	s RES, CHIP 10K (1608)
R617	1-218-895-91	s RES, CHIP 100K (1608)
R619	1-219-706-21	s RES, CHIP (SQUARE TYPE) 0.10
R620	1-216-809-91	s RES, CHIP 100 (1608)
R621	1-216-833-91	s RES, CHIP 10K (1608)
R622	1-216-829-91	s RES, CHIP 4.7K (1608)
R623	1-216-827-91	s RES, CHIP 3.3K (1608)
R624	1-216-822-91	s RES, CHIP 1.2K (1608)
R627	1-218-867-91	s RES, CHIP 6.8K (1608)
R628	1-218-901-91	s RES, CHIP 180K (1608)
R629	1-218-905-91	s RES, CHIP 270K (1608)
R630	1-218-881-91	s RES, CHIP 27K (1608)
R631	1-216-837-91	s RES, CHIP 22K (1608)
R632	1-218-873-91	s RES, CHIP 12K (1608)
R633	1-216-833-91	s RES, CHIP 10K (1608)
R634	1-216-833-91	s RES, CHIP 10K (1608)
R635	1-216-833-91	s RES, CHIP 10K (1608)
R636	1-218-901-91	s RES, CHIP 180K (1608)
R638	1-216-821-91	s RES, CHIP 1.0K (1608)
R640	1-218-849-91	s RES, CHIP 1.2K (1608)
R641	1-218-875-91	s RES, CHIP 15K (1608)
R642	1-218-861-91	s RES, CHIP 3.9K (1608)
R643	1-218-875-91	s RES, CHIP 15K (1608)
R644	1-218-863-91	s RES, CHIP 4.7K (1608)

(EA BOARD)

Ref. No. or Q'ty	Part No.	SP Description
R645	1-216-833-91	s RES, CHIP 10K (1608)
R646	1-216-833-91	s RES, CHIP 10K (1608)
R647	1-216-793-91	s RES, CHIP 4.7 (1608)
R648	1-216-793-91	s RES, CHIP 4.7 (1608)
R649	1-216-864-91	s CONDUCTOR, CHIP (1608)
R700	1-216-845-91	s RES, CHIP 100K (1608)
R701	1-216-805-91	s RES, CHIP 47 (1608)
R702	1-216-801-91	s RES, CHIP 22 (1608)
R703	1-216-809-91	s RES, CHIP 100 (1608)
R704	1-216-809-91	s RES, CHIP 100 (1608)
R705	1-216-809-91	s RES, CHIP 100 (1608)
R706	1-216-833-91	s RES, CHIP 10K (1608)
R707	1-216-809-91	s RES, CHIP 100 (1608)
R709	1-216-809-91	s RES, CHIP 100 (1608)
R710	1-216-833-91	s RES, CHIP 10K (1608)
R711	1-216-833-91	s RES, CHIP 10K (1608)
R712	1-216-805-91	s RES, CHIP 47 (1608)
R713	1-216-809-91	s RES, CHIP 100 (1608)
R714	1-216-833-91	s RES, CHIP 10K (1608)
R715	1-216-833-91	s RES, CHIP 10K (1608)
R717	1-216-809-91	s RES, CHIP 100 (1608)
R718	1-216-813-91	s RES, CHIP 220 (1608)
R719	1-216-821-91	s RES, CHIP 1.0K (1608)
R720	1-216-809-91	s RES, CHIP 100 (1608)
R721	1-216-809-91	s RES, CHIP 100 (1608)
R722	1-216-864-91	s CONDUCTOR, CHIP (1608)
R723	1-216-864-91	s CONDUCTOR, CHIP (1608)
R724	1-216-864-91	s CONDUCTOR, CHIP (1608)
R725	1-216-833-91	s RES, CHIP 10K (1608)
R726	1-216-821-91	s RES, CHIP 1.0K (1608)
R727	1-216-833-91	s RES, CHIP 10K (1608)
R728	1-216-821-91	s RES, CHIP 1.0K (1608)
R729	1-216-853-91	s RES, CHIP 470K (1608)
R730	1-216-853-91	s RES, CHIP 470K (1608)
R735	1-216-833-91	s RES, CHIP 10K (1608)
R736	1-216-809-91	s RES, CHIP 100 (1608)
R737	1-216-805-91	s RES, CHIP 47 (1608)
R738	1-216-809-91	s RES, CHIP 100 (1608)
R739	1-216-805-91	s RES, CHIP 47 (1608)
R740	1-216-821-91	s RES, CHIP 1.0K (1608)
R741	1-216-823-91	s RES, CHIP 1.5K (1608)
R742	1-216-809-91	s RES, CHIP 100 (1608)
R743	1-216-845-91	s RES, CHIP 100K (1608)
R744	1-216-833-91	s RES, CHIP 10K (1608)
R745	1-216-829-91	s RES, CHIP 4.7K (1608)
R746	1-216-833-91	s RES, CHIP 10K (1608)
R747	1-216-833-91	s RES, CHIP 10K (1608)
R748	1-216-833-91	s RES, CHIP 10K (1608)
R749	1-216-829-91	s RES, CHIP 4.7K (1608)
R750	1-218-871-91	s RES, CHIP 10K (1608)
R751	1-218-879-91	s RES, CHIP 22K (1608)
R752	1-218-883-91	s RES, CHIP 33K (1608)
R753	1-218-878-91	s RES, CHIP 20K (1608)
R754	1-216-833-91	s RES, CHIP 10K (1608)
R755	1-216-809-91	s RES, CHIP 100 (1608)
R756	1-216-809-91	s RES, CHIP 100 (1608)
R757	1-216-809-91	s RES, CHIP 100 (1608)
RB400	1-233-416-21	s RES, CHIP NETWORK 22K (3216)

(EA BOARD)

Ref. No. or Q'ty	Part No.	SP	Description
RB401	1-233-415-21	s	RES, CHIP NETWORK 10K (3216)
RB402	1-233-416-21	s	RES, CHIP NETWORK 22K (3216)
RB403	1-233-416-21	s	RES, CHIP NETWORK 22K (3216)
RB404	1-233-880-21	s	RES, NETWORK 68 (3216)
RB405	1-233-880-21	s	RES, NETWORK 68 (3216)
RB406	1-233-880-21	s	RES, NETWORK 68 (3216)
RB407	1-233-575-21	s	RES, CHIP NETWORK 22 (3216)
RB408	1-233-575-21	s	RES, CHIP NETWORK 22 (3216)
RB409	1-233-880-21	s	RES, NETWORK 68 (3216)
RB410	1-233-880-21	s	RES, NETWORK 68 (3216)
RB411	1-233-880-21	s	RES, NETWORK 68 (3216)
RB412	1-233-880-21	s	RES, NETWORK 68 (3216)
RB413	1-233-880-21	s	RES, NETWORK 68 (3216)
RB414	1-233-413-21	s	RES, CHIP NETWORK 2.2K (3216)
RB415	1-233-413-21	s	RES, CHIP NETWORK 2.2K (3216)
RB416	1-233-413-21	s	RES, CHIP NETWORK 2.2K (3216)
S300	1-771-709-21	s	SWITCH, SLIDE
TP200	1-535-877-22	s	CHIP, CHECKER
TP201	1-535-877-22	s	CHIP, CHECKER
TP202	1-535-877-22	s	CHIP, CHECKER
TP203	1-535-877-22	s	CHIP, CHECKER
TP204	1-535-877-22	s	CHIP, CHECKER
TP400	1-535-877-22	s	CHIP, CHECKER
TP401	1-535-877-22	s	CHIP, CHECKER
TP609	1-535-877-22	s	CHIP, CHECKER
TP610	1-535-877-22	s	CHIP, CHECKER
TP700	1-535-877-22	s	CHIP, CHECKER
TP701	1-535-877-22	s	CHIP, CHECKER
TP702	1-535-877-22	s	CHIP, CHECKER
TP703	1-535-877-22	s	CHIP, CHECKER
TP704	1-535-877-22	s	CHIP, CHECKER
TP705	1-535-877-22	s	CHIP, CHECKER
TP706	1-535-877-22	s	CHIP, CHECKER
TP707	1-535-877-22	s	CHIP, CHECKER
TP708	1-535-877-22	s	CHIP, CHECKER
X300	1-795-984-11	s	OSCILLATOR, CRYSTAL
X400	1-795-984-11	s	OSCILLATOR, CRYSTAL

E BOARD

Ref. No. or Q'ty	Part No.	SP	Description
1pc	A-1091-417-A	s	MOUNTED CIRCUIT BOARD, E
1pc	4-030-359-01	o	HEAT SINK, H. PIN (A1)
1pc	4-042-408-02	o	PIN(45), WIRE (A5)
1pc	4-053-101-02	o	SPACER, DY CONNECTOR
1pc	4-381-907-01	s	INSULATOR (A) (IC802(1))
30pcs	4-382-854-01	s	SCREW (M3X8), P, SW (+) (Q8(1),11(1),13(1),14(1),18(1), 21(1),26(1),27(1),30(1),32(1), 36(1),38(1),40(1)IC500(1),100(1), 101(1),102(1),Q700(1),701(1), SPRING(3),HEATSINK(D)(3), BRACKET HEAT(2)R57(1),58(1),PIN(1))
1pc	4-662-796-01	o	CLIP, COACHING
C1	1-162-970-91	s	CAP, CERAMIC 10000PF B 1608
C2	1-130-495-91	s	CAP, PE TEREPHTHALATE 0.1MF
C3	1-162-927-91	s	CAP, CERAMIC 100PF CH 1608
C4	1-164-230-91	s	CAP, CERAMIC 220PF CH 1608
C5	1-162-970-91	s	CAP, CERAMIC 10000PF B 1608
C6	1-111-242-91	s	CAP, ELECT 22MF
C7	1-127-573-91	s	CAP, CHIP CERAMIC 1MF B (2012)
C8	1-164-644-91	s	CAP, CERAMIC 330PF
C9	1-107-943-91	s	CAP, ELECT 10MF
C10	1-162-968-91	s	CAP,CHIP CERAMIC 4700PF B 1608
C11	1-127-573-91	s	CAP, CHIP CERAMIC 1MF B (2012)
C12	1-117-677-21	s	CAP, PP FILM (S) 3.3MF
C13	1-127-573-91	s	CAP, CHIP CERAMIC 1MF B (2012)
C14	1-164-645-91	s	CAP, CERAMIC 1000PF
C15	1-164-645-91	s	CAP, CERAMIC 1000PF
C16	1-127-573-91	s	CAP, CHIP CERAMIC 1MF B (2012)
C17	1-117-676-21	s	CAP, PP FILM (S) 2.7MF
C18	1-127-573-91	s	CAP, CHIP CERAMIC 1MF B (2012)
C19	1-125-787-91	s	CAP, CERAMIC 680PF
C20	1-125-787-91	s	CAP, CERAMIC 680PF
C21	1-112-341-11	s	CAP, METALIZED PP FILM 1000PF
C22	1-112-761-11	s	CAP, METALIZED PP FILM 3900PF
C23	1-112-760-11	s	CAP, METALIZED PP FILM 2200PF
C24	1-127-573-91	s	CAP, CHIP CERAMIC 1MF B (2012)
C25	1-117-407-11	s	CAP, ELECT 47MF
C26	1-117-672-21	s	CAP, PP FILM (S) 1.2MF
C27	1-125-787-91	s	CAP, CERAMIC 680PF
C28	1-125-787-91	s	CAP, CERAMIC 680PF
C29	1-137-350-51	s	CAP, PP FILM 0.015MF
C30	1-104-709-91	s	CAP, ELECT 4.7MF
C31	1-127-573-91	s	CAP, CHIP CERAMIC 1MF B (2012)
C32	1-127-573-91	s	CAP, CHIP CERAMIC 1MF B (2012)
C33	1-117-668-21	s	CAP, PP FILM (S) 0.56MF
C34	1-127-573-91	s	CAP, CHIP CERAMIC 1MF B (2012)
C35	1-127-573-91	s	CAP, CHIP CERAMIC 1MF B (2012)
C36	1-100-566-91	s	CAP, CHIP CERAMIC 0.1MF B 1608
C37	1-117-664-21	s	CAP, PP FILM (S) 0.27MF
C38	1-125-827-91	s	CAP, CHIP CERAMIC 1MF B
C39	1-162-970-91	s	CAP, CERAMIC 10000PF B 1608
C40	1-117-661-21	s	CAP, PP FILM (S) 0.15MF
C41	1-162-970-91	s	CAP, CERAMIC 10000PF B 1608
C42	1-119-858-21	s	CAP, PP FILM (S) 0.068MF
C43	1-107-882-91	s	CAP, ELECT 100MF
C44	1-162-970-91	s	CAP, CERAMIC 10000PF B 1608
C45	1-162-970-91	s	CAP, CERAMIC 10000PF B 1608
C46	1-131-985-21	s	CAP, PP FILM (S) 0.033MF
C47	1-125-827-91	s	CAP, CHIP CERAMIC 1MF B

(E BOARD)

Ref. No. or Q'ty	Part No.	SP Description
C48	1-117-664-11	s CAP, PP FILM (S) 0.27MF
C49	1-117-661-11	s CAP, PP FILM (S) 0.15MF
C50	1-117-661-11	s CAP, PP FILM (S) 0.15MF
C51	1-108-421-91	s CAP, PE TEREPHTHALATE 0.01MF
C52	1-125-827-91	s CAP, CHIP CERAMIC 1MF B
C53	1-162-970-91	s CAP, CERAMIC 10000PF B 1608
C100	1-107-492-91	s CAP, ELECT 47MF
C101	1-107-826-91	s CAP, CHIP CERAMIC 100000PF B
C102	1-107-826-91	s CAP, CHIP CERAMIC 100000PF B
C103	1-100-597-91	s CAP, CHIP CERAMIC 0.1MF B 1608
C104	1-100-597-91	s CAP, CHIP CERAMIC 0.1MF B 1608
C105	1-104-652-91	s CAP, ELECT 470MF
C106	1-104-652-91	s CAP, ELECT 470MF
C107	1-128-528-91	s CAP, ELECT 470MF
C108	1-128-528-91	s CAP, ELECT 470MF
C109	1-104-652-91	s CAP, ELECT 470MF
C110	1-104-652-91	s CAP, ELECT 470MF
C111	1-128-525-91	s CAP, ELECT 470MF
C112	1-128-525-91	s CAP, ELECT 470MF
C113	1-107-826-91	s CAP, CHIP CERAMIC 100000PF B
C114	1-107-826-91	s CAP, CHIP CERAMIC 100000PF B
C115	1-107-826-91	s CAP, CHIP CERAMIC 100000PF B
C116	1-107-826-91	s CAP, CHIP CERAMIC 100000PF B
C117	1-162-970-91	s CAP, CERAMIC 10000PF B 1608
C118	1-162-970-91	s CAP, CERAMIC 10000PF B 1608
C119	1-162-970-91	s CAP, CERAMIC 10000PF B 1608
C120	1-162-970-91	s CAP, CERAMIC 10000PF B 1608
C200	1-107-823-91	s CAP, CERAMIC 470000PF B (2012)
C201	1-115-416-91	s CAP,CHIP CERAMIC1000PF CH 1608
C300	1-136-497-81	s CAP, METALIZED FILM 0.1MF
C301	1-137-370-91	s CAP, PETP FILM 0.01MF
C302	1-107-882-91	s CAP, ELECT 100MF
C303	1-100-566-91	s CAP, CHIP CERAMIC 0.1MF B 1608
C304	1-100-566-91	s CAP, CHIP CERAMIC 0.1MF B 1608
C305	1-137-370-91	s CAP, PETP FILM 0.01MF
C306	1-165-176-91	s CAP,CERAMIC 47000PF B 1608
C307	1-107-882-91	s CAP, ELECT 100MF
C308	1-136-497-81	s CAP, METALIZED FILM 0.1MF
C309	1-136-497-81	s CAP, METALIZED FILM 0.1MF
C310	1-107-882-91	s CAP, ELECT 100MF
C311	1-107-882-91	s CAP, ELECT 100MF
C400	1-128-525-91	s CAP, ELECT 470MF
C401	1-100-566-91	s CAP, CHIP CERAMIC 0.1MF B 1608
C402	1-100-566-91	s CAP, CHIP CERAMIC 0.1MF B 1608
C403	1-128-525-91	s CAP, ELECT 470MF
C404	1-164-315-91	s CAP, CERAMIC 470PF CH (1608)
C405	1-115-416-91	s CAP,CHIP CERAMIC1000PF CH 1608
C407	1-111-242-91	s CAP, ELECT 22MF
C408	1-162-927-91	s CAP, CERAMIC 100PF CH 1608
C409	1-164-227-91	s CAP,CERAMIC 22000PF B 1608
C410	1-162-969-91	s CAP, CERAMIC 6800PF B 1608
C412	1-100-566-91	s CAP, CHIP CERAMIC 0.1MF B 1608
C413	1-162-969-91	s CAP, CERAMIC 6800PF B 1608
C414	1-162-966-91	s CAP, CERAMIC 2200PF B 1608
C415	1-162-964-91	s CAP,CHIP CERAMIC 1000PF B 1608
C416	1-107-882-91	s CAP, ELECT 100MF
C417	1-108-421-91	s CAP, PE TEREPHTHALATE 0.01MF
C418	1-110-641-11	s CAP, ELECT 33MF
C419	1-164-390-91	s CAP, CERAMIC 330PF CH 1608
C421	1-162-970-91	s CAP, CERAMIC 10000PF B 1608

(E BOARD)

Ref. No. or Q'ty	Part No.	SP Description
C422	1-162-915-91	s CAP, CERAMIC 10PF CH 1608
C500	1-128-525-91	s CAP, ELECT 470MF
C501	1-107-882-91	s CAP, ELECT 100MF
C502	1-162-970-91	s CAP, CERAMIC 10000PF B 1608
C503	1-128-525-91	s CAP, ELECT 470MF
C504	1-162-965-91	s CAP, CERAMIC 1500PF B 1608
C505	1-100-566-91	s CAP, CHIP CERAMIC 0.1MF B 1608
C506	1-162-970-91	s CAP, CERAMIC 10000PF B 1608
C507	1-162-970-91	s CAP, CERAMIC 10000PF B 1608
C508	1-162-970-91	s CAP, CERAMIC 10000PF B 1608
C509	1-107-888-91	s CAP, ELECT 47MF
C600	1-131-608-91	s CAP, CHIP CERAMIC 2.2MF B 3216
C601	1-107-906-91	s CAP, ELECT 10MF
C602	1-107-906-91	s CAP, ELECT 10MF
C603	1-107-906-91	s CAP, ELECT 10MF
C604	1-111-245-91	s CAP, ELECT 22MF
C605	1-111-242-91	s CAP, ELECT 22MF
C606	1-111-244-91	s CAP, ELECT 47MF
C607	1-107-906-91	s CAP, ELECT 10MF
C608	1-111-242-91	s CAP, ELECT 22MF
C609	1-162-970-91	s CAP, CERAMIC 10000PF B 1608
C610	1-107-906-91	s CAP, ELECT 10MF
C611	1-107-888-91	s CAP, ELECT 47MF
C612	1-111-239-91	s CAP, ELECT 47MF
C613	1-107-906-91	s CAP, ELECT 10MF
C614	1-162-970-91	s CAP, CERAMIC 10000PF B 1608
C615	1-125-827-91	s CAP, CHIP CERAMIC 1MF B
C616	1-162-970-91	s CAP, CERAMIC 10000PF B 1608
C617	1-125-827-91	s CAP, CHIP CERAMIC 1MF B
C618	1-115-340-91	s CAP, CERAMIC 0.22MF B (2012)
C619	1-162-970-91	s CAP, CERAMIC 10000PF B 1608
C620	1-115-340-91	s CAP, CERAMIC 0.22MF B (2012)
C621	1-162-970-91	s CAP, CERAMIC 10000PF B 1608
C622	1-162-970-91	s CAP, CERAMIC 10000PF B 1608
C700	1-162-970-91	s CAP, CERAMIC 10000PF B 1608
C701	1-162-970-91	s CAP, CERAMIC 10000PF B 1608
C702	1-100-566-91	s CAP, CHIP CERAMIC 0.1MF B 1608
C703	1-115-416-91	s CAP,CHIP CERAMIC1000PF CH 1608
C704	1-137-370-91	s CAP, PETP FILM 0.01MF
C800	1-107-826-91	s CAP, CHIP CERAMIC 100000PF B
C804	1-107-491-91	s CAP, ELECT 1000MF
C805	1-162-964-91	s CAP,CHIP CERAMIC 1000PF B 1608
C806	1-107-491-91	s CAP, ELECT 1000MF
C807	1-162-969-91	s CAP, CERAMIC 6800PF B 1608
C809	1-162-970-91	s CAP, CERAMIC 10000PF B 1608
C810	1-107-826-91	s CAP, CHIP CERAMIC 100000PF B
C811	1-162-968-91	s CAP,CHIP CERAMIC 4700PF B 1608
C812	1-137-401-51	s CAP, PETP FILM 0.22MF
C813	1-107-911-91	s CAP, ELECT 220MF
C814	1-136-497-81	s CAP, METALIZED FILM 0.1MF
C815	1-162-970-91	s CAP, CERAMIC 10000PF B 1608
C816	1-162-970-91	s CAP, CERAMIC 10000PF B 1608
C817	1-162-970-91	s CAP, CERAMIC 10000PF B 1608
C818	1-162-970-91	s CAP, CERAMIC 10000PF B 1608
CN1	1-580-798-11	o CONNECTOR PIN (DY) 6P
CN100	1-817-753-11	o CONNECTOR, BOARD TO BOARD 100P
CN101	1-817-753-11	o CONNECTOR, BOARD TO BOARD 100P
D1	8-719-404-50	s DIODE MA111-TX
D2	8-719-404-50	s DIODE MA111-TX

(E BOARD)

Ref. No. or Q'ty	Part No.	SP	Description
D4	8-719-030-44	s	DIODE 1R5GU41-TPA2
D5	8-719-404-50	s	DIODE MA111-TX
D6	8-719-404-50	s	DIODE MA111-TX
D7	8-719-052-31	s	DIODE D1NL40-TR2
D8	8-719-052-31	s	DIODE D1NL40-TR2
D9	8-719-303-21	s	DIODE RH-1AV1
D10	8-719-404-50	s	DIODE MA111-TX
D11	8-719-053-57	s	DIODE 5VUZ52
D12	8-719-936-83	s	DIODE GP08D-5001E3/23
D16	8-719-404-50	s	DIODE MA111-TX
D18	8-719-404-50	s	DIODE MA111-TX
D19	8-719-989-09	s	DIODE 1SS83TA
D20	8-719-404-50	s	DIODE MA111-TX
D21	8-719-037-22	s	DIODE RD12SB-T1
D200	8-719-404-50	s	DIODE MA111-TX
D201	8-719-404-50	s	DIODE MA111-TX
D202	8-719-404-50	s	DIODE MA111-TX
D203	8-719-404-50	s	DIODE MA111-TX
D204	8-719-404-50	s	DIODE MA111-TX
D205	8-719-404-50	s	DIODE MA111-TX
D206	8-719-404-50	s	DIODE MA111-TX
D207	8-719-404-50	s	DIODE MA111-TX
D208	8-719-404-50	s	DIODE MA111-TX
D209	8-719-404-50	s	DIODE MA111-TX
D210	8-719-404-50	s	DIODE MA111-TX
D211	8-719-404-50	s	DIODE MA111-TX
D212	8-719-404-50	s	DIODE MA111-TX
D213	8-719-404-50	s	DIODE MA111-TX
D214	8-719-404-50	s	DIODE MA111-TX
D216	8-719-404-50	s	DIODE MA111-TX
D217	8-719-404-50	s	DIODE MA111-TX
D300	8-719-921-20	s	DIODE 1SS119-25TD
D301	8-719-921-20	s	DIODE 1SS119-25TD
D401	8-719-404-50	s	DIODE MA111-TX
D402	8-719-404-50	s	DIODE MA111-TX
D403	8-719-404-50	s	DIODE MA111-TX
D404	8-719-404-50	s	DIODE MA111-TX
D405	8-719-404-50	s	DIODE MA111-TX
D406	8-719-404-50	s	DIODE MA111-TX
D407	8-719-404-50	s	DIODE MA111-TX
D408	8-719-036-94	s	DIODE RD5.6SB-T1
D409	8-719-404-50	s	DIODE MA111-TX
D410	6-500-219-01	s	DIODE 1SS404(TPH3)
D411	8-719-404-50	s	DIODE MA111-TX
D412	8-719-404-50	s	DIODE MA111-TX
D413	8-719-161-04	s	DIODE RD9.1SB-T1
D414	6-500-746-01	s	DIODE D8LC20UR-7015
D500	6-501-429-01	s	DIODE SF10NC15M
D501	8-719-404-50	s	DIODE MA111-TX
D502	8-719-404-50	s	DIODE MA111-TX
D503	8-719-036-80	s	DIODE RD3.9SB-T1
D504	6-501-429-01	s	DIODE SF10NC15M
D505	8-719-036-67	s	DIODE RD2.4SB-T1
D506	8-719-404-50	s	DIODE MA111-TX
D507	8-719-404-50	s	DIODE MA111-TX
D509	8-719-404-50	s	DIODE MA111-TX
D510	8-719-404-50	s	DIODE MA111-TX
D600	8-719-404-50	s	DIODE MA111-TX
D601	8-719-404-50	s	DIODE MA111-TX
D602	8-719-404-50	s	DIODE MA111-TX

(E BOARD)

Ref. No. or Q'ty	Part No.	SP	Description
D603	8-719-404-50	s	DIODE MA111-TX
D604	8-719-404-50	s	DIODE MA111-TX
D605	8-719-404-50	s	DIODE MA111-TX
D606	8-719-404-50	s	DIODE MA111-TX
D607	8-719-404-50	s	DIODE MA111-TX
D608	8-719-404-50	s	DIODE MA111-TX
D609	8-719-404-50	s	DIODE MA111-TX
D610	8-719-404-50	s	DIODE MA111-TX
D611	8-719-404-50	s	DIODE MA111-TX
D612	8-719-404-50	s	DIODE MA111-TX
D613	8-719-404-50	s	DIODE MA111-TX
D614	8-719-404-50	s	DIODE MA111-TX
D615	8-719-404-50	s	DIODE MA111-TX
D700	8-719-974-84	s	DIODE ERA91-02TP1
D800	8-719-936-83	s	DIODE GP08D-5001E3/23
D801	8-719-036-91	s	DIODE RD5.1SB-T1
FB400	1-543-963-22	s	BEAD, FERRITE (CHIP) (2012)
FB401	1-410-397-31	s	FERRITE BEAD INDUCTOR 1.1UH
FB402	1-410-397-31	s	FERRITE BEAD INDUCTOR 1.1UH
FB700	1-412-911-21	s	INDUCTOR, FERRITE BEAD
FB701	1-412-911-21	s	INDUCTOR, FERRITE BEAD
FL100	1-236-164-41	s	ENCAPSULATED COMPONENT
FL101	1-236-164-41	s	ENCAPSULATED COMPONENT
IC1	6-706-488-01	s	IC TC7SH14FU(T5RSOYJF)
IC2	8-759-276-28	s	IC LM393PS-E20
IC100	8-759-925-54	s	IC LM2940CT-5.0 NOPB
IC101	8-759-701-79	s	IC NJM7812FA
IC102	8-759-929-65	s	IC LM7912CT
IC103	8-759-539-89	s	IC LM2990SX-5.0
IC104	8-759-656-54	s	IC TC7WH14FK(TE85R)
IC105	8-752-072-94	s	IC CXA1875AM-T4
IC106	8-759-157-42	s	IC TL082CPS-E20
IC300	8-759-822-38	s	IC LA6510
IC301	8-759-803-42	s	IC LA6500-FA
IC400	8-759-585-82	s	IC BA9759F-E2
IC500	8-759-803-42	s	IC LA6500-FA
IC501	8-759-249-16	s	IC NJM4558M-TE2
IC502	8-759-276-28	s	IC LM393PS-E20
IC600	8-759-329-01	s	IC LM339NSR
IC601	8-759-329-01	s	IC LM339NSR
IC602	8-759-249-16	s	IC NJM4558M-TE2
IC700	8-759-157-42	s	IC TL082CPS-E20
IC800	8-759-157-42	s	IC TL082CPS-E20
IC801	8-759-157-42	s	IC TL082CPS-E20
IC802	8-759-696-71	s	IC STV9379A
L1	1-457-129-11	s	COIL, HORIZONTAL LINEARITY
L2	1-457-129-11	s	COIL, HORIZONTAL LINEARITY
L4	1-406-670-21	s	COIL, CHOKE 680UH
L5	1-406-989-21	s	COIL, CHOKE 10MMH
L6	1-406-673-21	s	COIL, CHOKE 2.2MMH
L7	1-406-673-21	s	COIL, CHOKE 2.2MMH
L400	1-406-661-21	s	COIL, CHOKE 22UH
L500	△ 1-406-892-11	s	COIL, CHOKE 4MMH
L700	1-419-884-11	s	COIL, HORIZONTAL LINEARITY
PS500	1-576-124-21	s	LINK, IC (1A/72V)
PS501	1-576-124-21	s	LINK, IC (1A/72V)

(E BOARD)

Ref. No. or Q'ty	Part No.	SP	Description
Q1	8-729-905-38	s	TRANSISTOR 2SC4081T106R
Q2	8-729-026-53	s	TRANSISTOR 2SA1576A-T106-QR
Q3	8-729-208-55	s	TRANSISTOR 2SC2878A-TPE2
Q4	8-729-208-55	s	TRANSISTOR 2SC2878A-TPE2
Q5	8-729-029-14	s	TRANSISTOR DTC144EUA-T106
Q6	8-729-048-47	s	TRANSISTOR 2SC2688 (5) -LK
Q7	8-729-029-14	s	TRANSISTOR DTC144EUA-T106
Q8	8-729-053-24	s	TRANSISTOR 2SK3262-01MR
Q9	8-729-026-53	s	TRANSISTOR 2SA1576A-T106-QR
Q10	8-729-029-14	s	TRANSISTOR DTC144EUA-T106
Q11	8-729-053-24	s	TRANSISTOR 2SK3262-01MR
Q12	8-729-029-14	s	TRANSISTOR DTC144EUA-T106
Q13	8-729-053-24	s	TRANSISTOR 2SK3262-01MR
Q14	8-729-053-24	s	TRANSISTOR 2SK3262-01MR
Q15	8-729-029-14	s	TRANSISTOR DTC144EUA-T106
Q16	6-550-880-01	s	TRANSISTOR 2SC5716 (LBSONY.F)
Q17	8-729-029-14	s	TRANSISTOR DTC144EUA-T106
Q18	8-729-053-24	s	TRANSISTOR 2SK3262-01MR
Q19	8-729-140-10	s	TRANSISTOR 2SA1221-T-KLM
Q20	8-729-044-21	s	TRANSISTOR 2SK2655-01R-F165
Q21	8-729-053-24	s	TRANSISTOR 2SK3262-01MR
Q22	8-729-034-60	s	TRANSISTOR 2SK2350
Q23	8-729-029-14	s	TRANSISTOR DTC144EUA-T106
Q24	8-729-029-14	s	TRANSISTOR DTC144EUA-T106
Q26	8-729-053-24	s	TRANSISTOR 2SK3262-01MR
Q27	8-729-053-24	s	TRANSISTOR 2SK3262-01MR
Q28	8-729-029-14	s	TRANSISTOR DTC144EUA-T106
Q30	8-729-053-24	s	TRANSISTOR 2SK3262-01MR
Q31	8-729-029-14	s	TRANSISTOR DTC144EUA-T106
Q32	8-729-053-24	s	TRANSISTOR 2SK3262-01MR
Q34	8-729-029-14	s	TRANSISTOR DTC144EUA-T106
Q35	8-729-029-14	s	TRANSISTOR DTC144EUA-T106
Q36	8-729-053-24	s	TRANSISTOR 2SK3262-01MR
Q37	8-729-029-14	s	TRANSISTOR DTC144EUA-T106
Q38	8-729-053-24	s	TRANSISTOR 2SK3262-01MR
Q39	8-729-029-14	s	TRANSISTOR DTC144EUA-T106
Q40	8-729-053-24	s	TRANSISTOR 2SK3262-01MR
Q41	8-729-029-14	s	TRANSISTOR DTC144EUA-T106
Q42	8-729-029-14	s	TRANSISTOR DTC144EUA-T106
Q100	8-729-028-91	s	TRANSISTOR DTA144EUA-T106
Q101	8-729-029-14	s	TRANSISTOR DTC144EUA-T106
Q200	8-729-028-91	s	TRANSISTOR DTA144EUA-T106
Q201	8-729-029-14	s	TRANSISTOR DTC144EUA-T106
Q202	8-729-028-91	s	TRANSISTOR DTA144EUA-T106
Q203	8-729-028-91	s	TRANSISTOR DTA144EUA-T106
Q204	8-729-028-91	s	TRANSISTOR DTA144EUA-T106
Q205	8-729-029-14	s	TRANSISTOR DTC144EUA-T106
Q206	8-729-029-14	s	TRANSISTOR DTC144EUA-T106
Q207	8-729-029-14	s	TRANSISTOR DTC144EUA-T106
Q400	8-729-029-14	s	TRANSISTOR DTC144EUA-T106
Q401	8-729-029-14	s	TRANSISTOR DTC144EUA-T106
Q402	8-729-029-14	s	TRANSISTOR DTC144EUA-T106
Q403	8-729-029-14	s	TRANSISTOR DTC144EUA-T106
Q404	8-729-028-91	s	TRANSISTOR DTA144EUA-T106
Q405	8-729-029-14	s	TRANSISTOR DTC144EUA-T106
Q406	8-729-231-96	s	TRANSISTOR 2SK880GR-TE85L
Q407	8-729-028-91	s	TRANSISTOR DTA144EUA-T106
Q408	8-729-029-14	s	TRANSISTOR DTC144EUA-T106
Q410	8-729-803-76	s	TRANSISTOR 2SA1371-E
Q411	8-729-019-85	s	TRANSISTOR 2SC3392-5-TB-E

(E BOARD)

Ref. No. or Q'ty	Part No.	SP	Description
Q412	8-729-824-24	s	TRANSISTOR 2SA1338-5-TB-E
Q413	8-729-050-13	s	TRANSISTOR 2SJ585LS-CC11
Q415	8-729-905-38	s	TRANSISTOR 2SC4081T106R
Q500	8-729-140-51	s	TRANSISTOR 2SC3209LK-TP
Q501	8-729-112-85	s	TRANSISTOR 2SA1330-T106
Q502	8-729-112-85	s	TRANSISTOR 2SA1330-T106
Q503	8-729-029-14	s	TRANSISTOR DTC144EUA-T106
Q504	8-729-029-14	s	TRANSISTOR DTC144EUA-T106
Q505	8-729-029-14	s	TRANSISTOR DTC144EUA-T106
Q506	8-729-029-14	s	TRANSISTOR DTC144EUA-T106
Q507	8-729-029-14	s	TRANSISTOR DTC144EUA-T106
Q508	8-729-029-14	s	TRANSISTOR DTC144EUA-T106
Q509	8-729-029-14	s	TRANSISTOR DTC144EUA-T106
Q510	8-729-029-14	s	TRANSISTOR DTC144EUA-T106
Q511	8-729-026-53	s	TRANSISTOR 2SA1576A-T106-QR
Q600	8-729-028-81	s	TRANSISTOR DTA123JUA-T106
Q601	8-729-029-14	s	TRANSISTOR DTC144EUA-T106
Q602	8-729-029-14	s	TRANSISTOR DTC144EUA-T106
Q603	8-729-028-91	s	TRANSISTOR DTA144EUA-T106
Q604	8-729-029-14	s	TRANSISTOR DTC144EUA-T106
Q605	8-729-028-81	s	TRANSISTOR DTA123JUA-T106
Q606	8-729-029-14	s	TRANSISTOR DTC144EUA-T106
Q607	8-729-029-04	s	TRANSISTOR DTC123JUA-T106
Q608	8-729-029-04	s	TRANSISTOR DTC123JUA-T106
Q609	8-729-029-14	s	TRANSISTOR DTC144EUA-T106
Q610	8-729-028-81	s	TRANSISTOR DTA123JUA-T106
Q611	8-729-028-81	s	TRANSISTOR DTA123JUA-T106
Q612	8-729-028-81	s	TRANSISTOR DTA123JUA-T106
Q613	8-729-029-04	s	TRANSISTOR DTC123JUA-T106
Q614	8-729-029-04	s	TRANSISTOR DTC123JUA-T106
Q615	8-729-029-14	s	TRANSISTOR DTC144EUA-T106
Q616	8-729-029-14	s	TRANSISTOR DTC144EUA-T106
Q617	8-729-029-04	s	TRANSISTOR DTC123JUA-T106
Q618	8-729-028-91	s	TRANSISTOR DTA144EUA-T106
Q619	8-729-029-14	s	TRANSISTOR DTC144EUA-T106
Q620	8-729-029-14	s	TRANSISTOR DTC144EUA-T106
Q621	8-729-028-81	s	TRANSISTOR DTA123JUA-T106
Q622	8-729-029-14	s	TRANSISTOR DTC144EUA-T106
Q623	8-729-029-14	s	TRANSISTOR DTC144EUA-T106
Q624	8-729-029-04	s	TRANSISTOR DTC123JUA-T106
Q625	8-729-029-14	s	TRANSISTOR DTC144EUA-T106
Q626	8-729-029-14	s	TRANSISTOR DTC144EUA-T106
Q627	8-729-029-14	s	TRANSISTOR DTC144EUA-T106
Q628	8-729-029-14	s	TRANSISTOR DTC144EUA-T106
Q629	8-729-029-14	s	TRANSISTOR DTC144EUA-T106
Q630	8-729-029-14	s	TRANSISTOR DTC144EUA-T106
Q631	8-729-029-14	s	TRANSISTOR DTC144EUA-T106
Q632	8-729-029-14	s	TRANSISTOR DTC144EUA-T106
Q633	8-729-029-14	s	TRANSISTOR DTC144EUA-T106
Q700	8-729-209-15	s	TRANSISTOR 2SD2012
Q701	8-729-209-60	s	TRANSISTOR 2SB1375
Q800	8-729-026-53	s	TRANSISTOR 2SA1576A-T106-QR
Q801	8-729-231-96	s	TRANSISTOR 2SK880GR-TE85L
Q802	8-729-026-53	s	TRANSISTOR 2SA1576A-T106-QR
Q803	8-729-905-38	s	TRANSISTOR 2SC4081T106R
Q900	8-729-026-53	s	TRANSISTOR 2SA1576A-T106-QR
R1	1-216-809-91	s	RES, CHIP 100 (1608)
R2	1-216-809-91	s	RES, CHIP 100 (1608)
R3	1-216-822-91	s	RES, CHIP 1.2K (1608)

(E BOARD)

Ref. No. or Q'ty	Part No.	SP	Description
R4	1-216-829-91	s RES,	CHIP 4.7K (1608)
R5	1-216-825-91	s RES,	CHIP 2.2K (1608)
R6	1-216-833-91	s RES,	CHIP 10K (1608)
R7	1-216-809-91	s RES,	CHIP 100 (1608)
R8	1-216-845-91	s RES,	CHIP 100K (1608)
R9	1-215-916-71	s RES,	METAL OXIDE FILM 680
R10	1-216-821-91	s RES,	CHIP 1.0K (1608)
R11	1-216-833-91	s RES,	CHIP 10K (1608)
R12	1-215-916-71	s RES,	METAL OXIDE FILM 680
R13	1-216-809-91	s RES,	CHIP 100 (1608)
R14	1-216-831-91	s RES,	CHIP 6.8K (1608)
R15	1-216-821-91	s RES,	CHIP 1.0K (1608)
R16	1-215-916-71	s RES,	METAL OXIDE FILM 680
R17	1-247-775-91	s RES,	CARBON (SMALL) 4.7
R18	1-216-829-91	s RES,	CHIP 4.7K (1608)
R19	1-216-845-91	s RES,	CHIP 100K (1608)
R20	1-216-833-91	s RES,	CHIP 10K (1608)
R21	1-216-833-91	s RES,	CHIP 10K (1608)
R22	1-216-845-91	s RES,	CHIP 100K (1608)
R23	1-216-462-71	s RES,	METAL OXIDE FILM 8.2K
R24	1-216-829-91	s RES,	CHIP 4.7K (1608)
R25	1-216-845-91	s RES,	CHIP 100K (1608)
R26	1-216-833-91	s RES,	CHIP 10K (1608)
R27	1-214-840-81	s RES,	METAL FILM 100
R28	1-215-879-51	s RES,	METAL OXIDE FILM 47K
R29	1-216-821-91	s RES,	CHIP 1.0K (1608)
R30	1-211-824-71	s RES,	FUSE 220
R31	1-216-829-91	s RES,	CHIP 4.7K (1608)
R32	1-216-845-91	s RES,	CHIP 100K (1608)
R33	1-211-824-71	s RES,	FUSE 220
R34	1-216-389-71	s RES,	METAL OXIDE FILM 1.0
R35	1-216-389-71	s RES,	METAL OXIDE FILM 1.0
R36	1-216-829-91	s RES,	CHIP 4.7K (1608)
R37	1-216-845-91	s RES,	CHIP 100K (1608)
R38	1-216-380-71	s RES,	METAL OXIDE FILM 8.2
R39	1-215-879-51	s RES,	METAL OXIDE FILM 47K
R40	1-216-821-91	s RES,	CHIP 1.0K (1608)
R41	1-216-829-91	s RES,	CHIP 4.7K (1608)
R42	1-216-833-91	s RES,	CHIP 10K (1608)
R43	1-216-845-91	s RES,	CHIP 100K (1608)
R44	1-216-833-91	s RES,	CHIP 10K (1608)
R45	1-216-829-91	s RES,	CHIP 4.7K (1608)
R46	1-216-845-91	s RES,	CHIP 100K (1608)
R47	1-216-833-91	s RES,	CHIP 10K (1608)
R48	1-216-833-91	s RES,	CHIP 10K (1608)
R49	1-215-879-51	s RES,	METAL OXIDE FILM 47K
R50	1-216-821-91	s RES,	CHIP 1.0K (1608)
R51	1-216-825-91	s RES,	CHIP 2.2K (1608)
R52	1-216-841-91	s RES,	CHIP 47K (1608)
R53	1-216-841-91	s RES,	CHIP 47K (1608)
R54	1-216-845-91	s RES,	CHIP 100K (1608)
R57	1-245-949-11	s RES,	METAL FILM 22
R58	1-245-949-11	s RES,	METAL FILM 22
R60	1-215-912-71	s RES,	METAL OXIDE FILM 150
R61	1-215-912-71	s RES,	METAL OXIDE FILM 150
R62	1-215-912-71	s RES,	METAL OXIDE FILM 150
R63	1-216-825-91	s RES,	CHIP 2.2K (1608)
R64	1-216-845-91	s RES,	CHIP 100K (1608)
R65	1-216-833-91	s RES,	CHIP 10K (1608)
R67	1-215-879-51	s RES,	METAL OXIDE FILM 47K

(E BOARD)

Ref. No. or Q'ty	Part No.	SP	Description
R68	1-216-821-91	s RES,	CHIP 1.0K (1608)
R69	1-216-821-91	s RES,	CHIP 1.0K (1608)
R70	1-216-833-91	s RES,	CHIP 10K (1608)
R71	1-216-845-91	s RES,	CHIP 100K (1608)
R72	1-260-130-81	s RES,	CARBON (SMALL TYPE) 390K
R75	1-216-821-91	s RES,	CHIP 1.0K (1608)
R76	1-216-845-91	s RES,	CHIP 100K (1608)
R77	1-218-873-91	s RES,	CHIP 12K (1608)
R78	1-216-833-91	s RES,	CHIP 10K (1608)
R79	1-218-887-91	s RES,	CHIP 47K (1608)
R80	1-218-878-91	s RES,	CHIP 20K (1608)
R81	1-215-879-51	s RES,	METAL OXIDE FILM 47K
R82	1-216-829-91	s RES,	CHIP 4.7K (1608)
R83	1-216-809-91	s RES,	CHIP 100 (1608)
R84	1-218-879-91	s RES,	CHIP 22K (1608)
R85	1-216-845-91	s RES,	CHIP 100K (1608)
R86	1-215-879-51	s RES,	METAL OXIDE FILM 47K
R87	1-216-829-91	s RES,	CHIP 4.7K (1608)
R88	1-216-809-91	s RES,	CHIP 100 (1608)
R89	1-216-845-91	s RES,	CHIP 100K (1608)
R90	1-215-879-51	s RES,	METAL OXIDE FILM 47K
R91	1-216-829-91	s RES,	CHIP 4.7K (1608)
R92	1-216-809-91	s RES,	CHIP 100 (1608)
R93	1-216-857-91	s RES,	CHIP 1.0M (1608)
R94	1-216-845-91	s RES,	CHIP 100K (1608)
R95	1-216-838-91	s RES,	CHIP 27K (1608)
R96	1-215-879-51	s RES,	METAL OXIDE FILM 47K
R97	1-214-913-81	s RES,	METAL FILM 100K
R98	1-218-874-91	s RES,	CHIP 13K (1608)
R99	1-218-870-91	s RES,	CHIP 9.1K (1608)
R100	1-216-809-91	s RES,	CHIP 100 (1608)
R101	1-216-805-91	s RES,	CHIP 47 (1608)
R102	1-216-833-91	s RES,	CHIP 10K (1608)
R103	1-216-833-91	s RES,	CHIP 10K (1608)
R104	1-216-864-91	s CONDUCTOR,	CHIP (1608)
R105	1-216-864-91	s CONDUCTOR,	CHIP (1608)
R106	1-216-864-91	s CONDUCTOR,	CHIP (1608)
R107	1-216-833-91	s RES,	CHIP 10K (1608)
R108	1-216-833-91	s RES,	CHIP 10K (1608)
R109	1-216-813-91	s RES,	CHIP 220 (1608)
R110	1-216-813-91	s RES,	CHIP 220 (1608)
R111	1-216-809-91	s RES,	CHIP 100 (1608)
R112	1-218-871-91	s RES,	CHIP 10K (1608)
R113	1-218-902-91	s RES,	CHIP 200K (1608)
R114	1-216-809-91	s RES,	CHIP 100 (1608)
R115	1-216-809-91	s RES,	CHIP 100 (1608)
R116	1-216-809-91	s RES,	CHIP 100 (1608)
R117	1-216-809-91	s RES,	CHIP 100 (1608)
R118	1-216-809-91	s RES,	CHIP 100 (1608)
R120	1-216-295-91	s CONDUCTOR,	CHIP (2012)
R121	1-216-295-91	s CONDUCTOR,	CHIP (2012)
R123	1-216-809-91	s RES,	CHIP 100 (1608)
R124	1-216-864-91	s CONDUCTOR,	CHIP (1608)
R125	1-216-864-91	s CONDUCTOR,	CHIP (1608)
R127	1-216-864-91	s CONDUCTOR,	CHIP (1608)
R200	1-216-821-91	s RES,	CHIP 1.0K (1608)
R201	1-216-857-91	s RES,	CHIP 1.0M (1608)
R202	1-216-821-91	s RES,	CHIP 1.0K (1608)
R203	1-216-821-91	s RES,	CHIP 1.0K (1608)
R205	1-216-833-91	s RES,	CHIP 10K (1608)

(E BOARD)

Ref. No. or Q'ty	Part No.	SP Description
R206	1-216-833-91	s RES, CHIP 10K (1608)
R207	1-216-833-91	s RES, CHIP 10K (1608)
R208	1-216-833-91	s RES, CHIP 10K (1608)
R209	1-216-833-91	s RES, CHIP 10K (1608)
R210	1-216-833-91	s RES, CHIP 10K (1608)
R211	1-216-833-91	s RES, CHIP 10K (1608)
R212	1-216-833-91	s RES, CHIP 10K (1608)
R300	1-249-425-91	s RES, CARBON (SMALL) 4.7K
R301	1-249-392-91	s RES, CARBON (SMALL) 8.2
R302	1-249-377-91	s RES, CARBON (SMALL) 0.47
R303	1-247-767-91	s RES, CARBON (SMALL) 2.2
R304	1-247-783-91	s RES, CARBON (SMALL) 10
R305	1-216-826-91	s RES, CHIP 2.7K (1608)
R306	1-216-841-91	s RES, CHIP 47K (1608)
R307	1-216-821-91	s RES, CHIP 1.0K (1608)
R308	1-216-833-91	s RES, CHIP 10K (1608)
R309	1-216-821-91	s RES, CHIP 1.0K (1608)
R310	1-216-824-91	s RES, CHIP 1.8K (1608)
R311	1-216-839-91	s RES, CHIP 33K (1608)
R312	1-218-871-91	s RES, CHIP 10K (1608)
R313	1-218-871-91	s RES, CHIP 10K (1608)
R314	1-218-883-91	s RES, CHIP 33K (1608)
R315	1-216-847-91	s RES, CHIP 150K (1608)
R316	1-216-837-91	s RES, CHIP 22K (1608)
R317	1-218-883-91	s RES, CHIP 33K (1608)
R318	1-218-871-91	s RES, CHIP 10K (1608)
R319	1-247-767-91	s RES, CARBON (SMALL) 2.2
R320	1-247-783-91	s RES, CARBON (SMALL) 10
R321	1-249-377-91	s RES, CARBON (SMALL) 0.47
R322	1-247-783-91	s RES, CARBON (SMALL) 10
R323	1-249-433-91	s RES, CARBON (SMALL) 22K
R324	1-249-401-91	s RES, CARBON (SMALL) 47
R325	1-249-377-91	s RES, CARBON (SMALL) 0.47
R326	1-249-414-91	s RES, CARBON (SMALL) 560
R327	1-249-393-91	s RES, CARBON (SMALL) 10
R400	1-216-833-91	s RES, CHIP 10K (1608)
R401	1-216-833-91	s RES, CHIP 10K (1608)
R402	1-216-825-91	s RES, CHIP 2.2K (1608)
R403	1-218-867-91	s RES, CHIP 6.8K (1608)
R404	1-216-833-91	s RES, CHIP 10K (1608)
R406	1-218-863-91	s RES, CHIP 4.7K (1608)
R408	1-218-880-91	s RES, CHIP 24K (1608)
R410	1-216-833-91	s RES, CHIP 10K (1608)
R411	1-218-855-91	s RES, CHIP 2.2K (1608)
R412	1-218-888-91	s RES, CHIP 51K (1608)
R413	1-218-863-91	s RES, CHIP 4.7K (1608)
R415	1-218-865-91	s RES, CHIP 5.6K (1608)
R416	1-218-854-91	s RES, CHIP 2.0K (1608)
R417	1-218-895-91	s RES, CHIP 100K (1608)
R418	1-216-845-91	s RES, CHIP 100K (1608)
R419	1-218-887-91	s RES, CHIP 47K (1608)
R420	1-216-809-91	s RES, CHIP 100 (1608)
R421	1-218-889-91	s RES, CHIP 56K (1608)
R422	1-218-857-91	s RES, CHIP 2.7K (1608)
R423	1-218-879-91	s RES, CHIP 22K (1608)
R424	1-218-851-91	s RES, CHIP 1.5K (1608)
R425	1-218-859-91	s RES, CHIP 3.3K (1608)
R426	1-218-879-91	s RES, CHIP 22K (1608)
R427	1-218-879-91	s RES, CHIP 22K (1608)
R428	1-218-879-91	s RES, CHIP 22K (1608)

(E BOARD)

Ref. No. or Q'ty	Part No.	SP Description
R429	1-218-869-91	s RES, CHIP 8.2K (1608)
R430	1-216-833-91	s RES, CHIP 10K (1608)
R431	1-216-821-91	s RES, CHIP 1.0K (1608)
R432	1-216-833-91	s RES, CHIP 10K (1608)
R433	1-216-809-91	s RES, CHIP 100 (1608)
R434	1-218-886-91	s RES, CHIP 43K (1608)
R435	1-218-847-91	s RES, CHIP 1.0K (1608)
R436	1-215-479-91	s RES, METAL FILM (SMALL TYPE) 270K
R437	1-216-829-91	s RES, CHIP 4.7K (1608)
R438	1-216-369-71	s RES, METAL OXIDE FILM 1.0
R439	1-215-473-91	s RES, METAL FILM (SMALL TYPE) 150K
R440	1-216-833-91	s RES, CHIP 10K (1608)
R441	1-215-479-91	s RES, METAL FILM (SMALL TYPE) 270K
R442	1-216-837-91	s RES, CHIP 22K (1608)
R443	1-249-397-91	s RES, CARBON (SMALL) 22
R453	1-216-864-91	s CONDUCTOR, CHIP (1608)
R454	1-216-864-91	s CONDUCTOR, CHIP (1608)
R455	1-216-821-91	s RES, CHIP 1.0K (1608)
R456	1-216-825-91	s RES, CHIP 2.2K (1608)
R500	1-249-381-91	s RES, CARBON (SMALL) 1
R501	1-216-809-91	s RES, CHIP 100 (1608)
R502	1-216-809-91	s RES, CHIP 100 (1608)
R503	1-218-891-91	s RES, CHIP 68K (1608)
R504	1-249-381-91	s RES, CARBON (SMALL) 1
R505	1-216-369-71	s RES, METAL OXIDE FILM 1.0
R506	1-216-821-91	s RES, CHIP 1.0K (1608)
R507	1-218-855-91	s RES, CHIP 2.2K (1608)
R508	1-218-847-91	s RES, CHIP 1.0K (1608)
R509	1-216-821-91	s RES, CHIP 1.0K (1608)
R510	1-218-847-91	s RES, CHIP 1.0K (1608)
R511	1-216-853-91	s RES, CHIP 470K (1608)
R512	1-218-885-91	s RES, CHIP 39K (1608)
R513	1-218-878-91	s RES, CHIP 20K (1608)
R514	1-218-865-91	s RES, CHIP 5.6K (1608)
R515	1-218-873-91	s RES, CHIP 12K (1608)
R516	1-218-856-91	s RES, CHIP 2.4K (1608)
R517	1-218-891-91	s RES, CHIP 68K (1608)
R518	1-218-891-91	s RES, CHIP 68K (1608)
R519	1-218-891-91	s RES, CHIP 68K (1608)
R520	1-218-889-91	s RES, CHIP 56K (1608)
R521	1-218-889-91	s RES, CHIP 56K (1608)
R522	1-216-833-91	s RES, CHIP 10K (1608)
R523	1-216-845-91	s RES, CHIP 100K (1608)
R524	1-216-833-91	s RES, CHIP 10K (1608)
R525	1-216-833-91	s RES, CHIP 10K (1608)
R526	1-218-871-91	s RES, CHIP 10K (1608)
R527	1-218-863-91	s RES, CHIP 4.7K (1608)
R528	1-216-833-91	s RES, CHIP 10K (1608)
R529	1-216-833-91	s RES, CHIP 10K (1608)
R530	1-216-821-91	s RES, CHIP 1.0K (1608)
R531	1-216-821-91	s RES, CHIP 1.0K (1608)
R600	1-216-833-91	s RES, CHIP 10K (1608)
R601	1-216-847-91	s RES, CHIP 150K (1608)
R602	1-216-833-91	s RES, CHIP 10K (1608)
R603	1-216-833-91	s RES, CHIP 10K (1608)
R604	1-216-821-91	s RES, CHIP 1.0K (1608)
R605	1-216-823-91	s RES, CHIP 1.5K (1608)
R606	1-216-827-91	s RES, CHIP 3.3K (1608)
R608	1-216-833-91	s RES, CHIP 10K (1608)
R610	1-216-822-91	s RES, CHIP 1.2K (1608)

(E BOARD)

Ref. No. or Q'ty	Part No.	SP	Description
R611	1-216-827-91	s RES,	CHIP 3.3K (1608)
R612	1-216-822-91	s RES,	CHIP 1.2K (1608)
R613	1-216-827-91	s RES,	CHIP 3.3K (1608)
R614	1-216-833-91	s RES,	CHIP 10K (1608)
R616	1-216-833-91	s RES,	CHIP 10K (1608)
R617	1-216-833-91	s RES,	CHIP 10K (1608)
R618	1-216-822-91	s RES,	CHIP 1.2K (1608)
R619	1-216-827-91	s RES,	CHIP 3.3K (1608)
R620	1-216-833-91	s RES,	CHIP 10K (1608)
R621	1-216-833-91	s RES,	CHIP 10K (1608)
R622	1-216-833-91	s RES,	CHIP 10K (1608)
R623	1-216-833-91	s RES,	CHIP 10K (1608)
R624	1-216-833-91	s RES,	CHIP 10K (1608)
R625	1-216-833-91	s RES,	CHIP 10K (1608)
R626	1-216-833-91	s RES,	CHIP 10K (1608)
R627	1-216-833-91	s RES,	CHIP 10K (1608)
R628	1-216-864-91	s CONDUCTOR,	CHIP (1608)
R629	1-216-857-91	s RES,	CHIP 1.0M (1608)
R630	1-216-833-91	s RES,	CHIP 10K (1608)
R631	1-216-833-91	s RES,	CHIP 10K (1608)
R632	1-216-864-91	s CONDUCTOR,	CHIP (1608)
R633	1-216-857-91	s RES,	CHIP 1.0M (1608)
R634	1-216-833-91	s RES,	CHIP 10K (1608)
R635	1-216-833-91	s RES,	CHIP 10K (1608)
R636	1-216-833-91	s RES,	CHIP 10K (1608)
R638	1-216-833-91	s RES,	CHIP 10K (1608)
R639	1-216-864-91	s CONDUCTOR,	CHIP (1608)
R640	1-216-849-91	s RES,	CHIP 220K (1608)
R641	1-216-864-91	s CONDUCTOR,	CHIP (1608)
R642	1-216-849-91	s RES,	CHIP 220K (1608)
R643	1-218-863-91	s RES,	CHIP 4.7K (1608)
R644	1-218-871-91	s RES,	CHIP 10K (1608)
R645	1-216-864-91	s CONDUCTOR,	CHIP (1608)
R646	1-216-864-91	s CONDUCTOR,	CHIP (1608)
R647	1-216-857-91	s RES,	CHIP 1.0M (1608)
R648	1-216-841-91	s RES,	CHIP 47K (1608)
R649	1-216-841-91	s RES,	CHIP 47K (1608)
R650	1-218-875-91	s RES,	CHIP 15K (1608)
R651	1-218-857-91	s RES,	CHIP 2.7K (1608)
R652	1-216-850-91	s RES,	CHIP 270K (1608)
R653	1-216-821-91	s RES,	CHIP 1.0K (1608)
R654	1-216-821-91	s RES,	CHIP 1.0K (1608)
R655	1-216-850-91	s RES,	CHIP 270K (1608)
R656	1-216-833-91	s RES,	CHIP 10K (1608)
R657	1-218-865-91	s RES,	CHIP 5.6K (1608)
R658	1-218-871-91	s RES,	CHIP 10K (1608)
R659	1-218-895-91	s RES,	CHIP 100K (1608)
R660	1-216-833-91	s RES,	CHIP 10K (1608)
R661	1-218-895-91	s RES,	CHIP 100K (1608)
R662	1-218-869-91	s RES,	CHIP 8.2K (1608)
R663	1-218-871-91	s RES,	CHIP 10K (1608)
R700	1-218-855-91	s RES,	CHIP 2.2K (1608)
R701	1-218-871-91	s RES,	CHIP 10K (1608)
R702	1-218-848-91	s RES,	CHIP 1.1K (1608)
R703	1-216-864-91	s CONDUCTOR,	CHIP (1608)
R704	1-216-864-91	s CONDUCTOR,	CHIP (1608)
R705	1-215-453-91	s RES,	METAL FILM(SMALL TYPE)22K
R706	1-216-821-91	s RES,	CHIP 1.0K (1608)
R707	1-215-884-71	s RES,	METAL OXIDE FILM 47
R708	1-215-913-71	s RES,	METAL OXIDE FILM 220

(E BOARD)

Ref. No. or Q'ty	Part No.	SP	Description
R709	1-215-913-71	s RES,	METAL OXIDE FILM 220
R803	1-218-871-91	s RES,	CHIP 10K (1608)
R804	1-218-871-91	s RES,	CHIP 10K (1608)
R805	1-218-871-91	s RES,	CHIP 10K (1608)
R807	1-216-841-91	s RES,	CHIP 47K (1608)
R808	1-218-871-91	s RES,	CHIP 10K (1608)
R809	1-216-833-91	s RES,	CHIP 10K (1608)
R810	1-218-871-91	s RES,	CHIP 10K (1608)
R811	1-216-841-91	s RES,	CHIP 47K (1608)
R812	1-218-879-91	s RES,	CHIP 22K (1608)
R813	1-218-889-91	s RES,	CHIP 56K (1608)
R814	1-260-292-71	s RES,	CARBON 1.0
R815	1-218-871-91	s RES,	CHIP 10K (1608)
R816	1-218-855-91	s RES,	CHIP 2.2K (1608)
R817	1-260-292-71	s RES,	CARBON 1.0
R818	1-216-835-91	s RES,	CHIP 15K (1608)
R819	1-218-856-91	s RES,	CHIP 2.4K (1608)
R820	1-218-855-91	s RES,	CHIP 2.2K (1608)
R821	1-218-875-91	s RES,	CHIP 15K (1608)
R822	1-218-879-91	s RES,	CHIP 22K (1608)
R823	1-218-871-91	s RES,	CHIP 10K (1608)
R824	1-218-856-91	s RES,	CHIP 2.4K (1608)
R825	1-249-381-91	s RES,	CARBON (SMALL) 1
R826	1-216-833-91	s RES,	CHIP 10K (1608)
R827	1-216-833-91	s RES,	CHIP 10K (1608)
R828	1-214-798-81	s RES,	METAL FILM 1.8
R829	1-215-865-71	s RES,	METAL OXIDE FILM 220
R830	1-214-798-81	s RES,	METAL FILM 1.8
R831	1-216-829-91	s RES,	CHIP 4.7K (1608)
R832	1-216-809-91	s RES,	CHIP 100 (1608)
R833	1-216-829-91	s RES,	CHIP 4.7K (1608)
R900	1-216-805-91	s RES,	CHIP 47 (1608)
R901	1-216-821-91	s RES,	CHIP 1.0K (1608)
R902	1-216-827-91	s RES,	CHIP 3.3K (1608)
R903	1-216-827-91	s RES,	CHIP 3.3K (1608)
R904	1-216-827-91	s RES,	CHIP 3.3K (1608)
RY1	1-755-129-11	s RELAY	
T1	Δ 1-431-443-11	s TRANSFORMER,	FERRITE (HST)
T2	Δ 1-427-762-11	s TRANSFORMER,	FERRITE (HDT)
T3	1-435-183-11	s TRANSFORMER,	FERRITE (HOT)
TH801	1-807-925-21	s THERMISTOR	
TP1	1-535-877-22	s CHIP,	CHECKER
TP2	1-535-877-22	s CHIP,	CHECKER
TP3	1-508-784-14	o PIN,	CONNECTOR (5MM PITCH) 1P
TP101	1-535-877-22	s CHIP,	CHECKER
TP105	1-535-877-22	s CHIP,	CHECKER
TP106	1-535-877-22	s CHIP,	CHECKER
TP107	1-535-877-22	s CHIP,	CHECKER
TP108	1-535-877-22	s CHIP,	CHECKER
TP300	1-535-877-22	s CHIP,	CHECKER
TP700	1-535-877-22	s CHIP,	CHECKER
TP800	1-535-877-22	s CHIP,	CHECKER
TP801	1-535-877-22	s CHIP,	CHECKER

G BOARD

Ref. No. or Q'ty	Part No.	SP	Description
1pc	A-1091-093-A	s	MOUNTED CIRCUIT BOARD, G
3pcs	4-382-854-51	s	SCREW (M3X6), P, SW (+)
1pc	4-030-359-01	o	HEAT SINK, H. PIN (A001)
11pcs	4-382-854-01	s	SCREW (M3X8), P, SW (+) (IC2 (1), Q601 (1), D601 (1), Q603 (1), Q604 (1), Q602 (1), IC102 (1), D204 (1), D206 (1), FLOATING (2))
3pcs	4-382-854-11	s	SCREW (M3X10), P, SW (+) (D106 (1), D1 (1), D205 (1))
1pc	7-322-065-48	o	RUBBER, SILICONE RTV (KE-3490) (R624 (1))
C1	△ 1-165-540-11	s	CAP, FILM 0.47MF
C2	△ 1-113-907-51	s	CAP, CERAMIC 2200PF E
C3	△ 1-113-907-51	s	CAP, CERAMIC 2200PF E
C4	△ 1-165-540-11	s	CAP, FILM 0.47MF
C5	1-113-924-91	s	CAP, CERAMIC 4700PF E
C6	1-113-924-91	s	CAP, CERAMIC 4700PF E
C7	1-117-228-11	s	CAP, METALIZED PE FILM 2.2MF
C8	1-107-910-91	s	CAP, ELECT 100MF
C9	1-111-240-91	s	CAP, ELECT 100MF
C10	1-162-970-91	s	CAP, CERAMIC 10000PF B 1608
C11	1-107-906-91	s	CAP, ELECT 10MF
C12	1-162-970-91	s	CAP, CERAMIC 10000PF B 1608
C13	1-162-970-91	s	CAP, CERAMIC 10000PF B 1608
C14	1-107-909-91	s	CAP, ELECT 47MF
C15	1-107-909-91	s	CAP, ELECT 47MF
C18	1-107-909-91	s	CAP, ELECT 47MF
C104	1-104-653-91	s	CAP, ELECT 220MF
C105	1-115-785-91	s	CAP, ELECT 470MF
C106	1-100-566-91	s	CAP, CHIP CERAMIC 0.1MF B 1608
C107	1-107-909-91	s	CAP, ELECT 47MF
C108	1-115-741-91	s	CAP, ELECT 2200MF
C109	1-115-741-91	s	CAP, ELECT 2200MF
C110	1-115-741-91	s	CAP, ELECT 2200MF
C111	1-115-785-91	s	CAP, ELECT 470MF
C112	1-107-909-91	s	CAP, ELECT 47MF
C115	1-115-340-91	s	CAP, CERAMIC 0.22MF B (2012)
C117	1-107-877-91	s	CAP, ELECT 1000MF
C212	1-107-909-91	s	CAP, ELECT 47MF
C213	1-115-789-91	s	CAP, ELECT 1000MF
C214	1-115-789-91	s	CAP, ELECT 1000MF
C215	1-115-789-91	s	CAP, ELECT 1000MF
C216	1-115-789-91	s	CAP, ELECT 1000MF
C217	1-115-741-91	s	CAP, ELECT 2200MF
C218	1-115-741-91	s	CAP, ELECT 2200MF
C219	1-115-741-91	s	CAP, ELECT 2200MF
C220	1-115-741-91	s	CAP, ELECT 2200MF
C221	1-110-641-51	s	CAP, ELECT 33MF
C222	1-110-641-51	s	CAP, ELECT 33MF
C223	1-162-970-91	s	CAP, CERAMIC 10000PF B 1608
C224	1-162-970-91	s	CAP, CERAMIC 10000PF B 1608
C225	1-100-566-91	s	CAP, CHIP CERAMIC 0.1MF B 1608
C226	1-162-970-91	s	CAP, CERAMIC 10000PF B 1608
C227	1-162-970-91	s	CAP, CERAMIC 10000PF B 1608
C228	1-100-566-91	s	CAP, CHIP CERAMIC 0.1MF B 1608
C229	1-162-970-91	s	CAP, CERAMIC 10000PF B 1608
C230	1-162-970-91	s	CAP, CERAMIC 10000PF B 1608
C231	1-100-566-91	s	CAP, CHIP CERAMIC 0.1MF B 1608
C232	1-162-970-91	s	CAP, CERAMIC 10000PF B 1608
C233	1-162-970-91	s	CAP, CERAMIC 10000PF B 1608
C234	1-100-566-91	s	CAP, CHIP CERAMIC 0.1MF B 1608

(G BOARD)

Ref. No. or Q'ty	Part No.	SP	Description
C235	1-128-528-91	s	CAP, ELECT 470MF
C236	1-128-528-91	s	CAP, ELECT 470MF
C237	1-107-877-91	s	CAP, ELECT 1000MF
C238	1-107-877-91	s	CAP, ELECT 1000MF
C239	1-107-952-91	s	CAP, ELECT 22MF
C601	1-115-416-91	s	CAP, CHIP CERAMIC 1000PF CH 1608
C602	1-162-927-91	s	CAP, CERAMIC 100PF CH 1608
C603	1-162-964-91	s	CAP, CHIP CERAMIC 1000PF B 1608
C604	1-115-467-91	s	CAP, CHIP CERAMIC 0.22MF B 1608
C605	1-162-968-91	s	CAP, CHIP CERAMIC 4700PF B 1608
C606	1-162-962-91	s	CAP, CERAMIC 470PF B 1608
C607	1-162-966-91	s	CAP, CERAMIC 2200PF B 1608
C608	1-100-566-91	s	CAP, CHIP CERAMIC 0.1MF B 1608
C609	1-107-903-91	s	CAP, ELECT 2.2MF
C610	1-107-911-91	s	CAP, ELECT 220MF
C611	1-130-018-41	s	CAP, PP FILM 1000PF
C612	1-136-497-81	s	CAP, METALIZED FILM 0.1MF
C613	1-107-905-91	s	CAP, ELECT 4.7MF
C614	1-107-903-91	s	CAP, ELECT 2.2MF
C615	1-162-964-91	s	CAP, CHIP CERAMIC 1000PF B 1608
C617	1-104-341-21	s	CAP, FILM 0.1MF
C618	1-107-906-91	s	CAP, ELECT 10MF
C619	1-107-792-81	s	CAP, CERAMIC 100PF SL
C620	1-137-756-22	s	CAP, METALIZED PP FILM 22000PF
C621	1-107-792-81	s	CAP, CERAMIC 100PF SL
C623	1-136-205-61	s	CAP, METALIZED FILM 0.022MF
C626	1-115-416-91	s	CAP, CHIP CERAMIC 1000PF CH 1608
C627	△ 1-117-600-11	s	CAP, ALUMINIUM ELECT 330MF
C651	1-137-370-91	s	CAP, PETP FILM 0.01MF
C801	1-115-438-91	s	CAP, ELECT 100MF
C802	1-162-970-91	s	CAP, CERAMIC 10000PF B 1608
C803	1-107-696-91	s	CAP, ELECT 47MF
C804	1-107-882-91	s	CAP, ELECT 100MF
C805	1-107-882-91	s	CAP, ELECT 100MF
C806	1-107-882-91	s	CAP, ELECT 100MF
C807	1-107-882-91	s	CAP, ELECT 100MF
C808	1-100-566-91	s	CAP, CHIP CERAMIC 0.1MF B 1608
C809	1-107-909-91	s	CAP, ELECT 47MF
C810	1-100-566-91	s	CAP, CHIP CERAMIC 0.1MF B 1608
C901	△ 1-113-907-51	s	CAP, CERAMIC 2200PF E
C902	1-100-566-91	s	CAP, CHIP CERAMIC 0.1MF B 1608
CN1	△ 1-691-961-11	o	PIN, CONNECTOR (PC BOARD) 3P
CN2	△ 1-695-561-11	o	PIN, CONNECTOR (PC BOARD) 7P
CN3	1-817-753-11	o	CONNECTOR, BOARD TO BOARD 100P
D1	△ 8-719-022-99	s	DIODE D6SB60L
D2	8-719-037-54	s	DIODE RD30SB-T1
D3	8-719-404-50	s	DIODE MA111-TX
D4	8-719-979-23	s	DIODE RGP02-17PKG23
D6	8-719-037-53	s	DIODE RD27SB-T1
D8	8-719-404-50	s	DIODE MA111-TX
D9	8-719-404-50	s	DIODE MA111-TX
D10	8-719-404-50	s	DIODE MA111-TX
D12	8-719-404-50	s	DIODE MA111-TX
D16	8-719-404-50	s	DIODE MA111-TX
D105	8-719-027-43	s	DIODE S2L20UF
D106	8-719-510-41	s	DIODE D10SC9M
D107	8-719-063-74	s	DIODE D1NL20U-TR2
D108	8-719-060-27	s	DIODE SLR-325MCT31
D204	8-719-060-88	s	DIODE D4SB56

(G BOARD)

Ref. No. or Q'ty	Part No.	SP	Description
D205	8-719-052-28	s	DIODE D10SBS4
D206	8-719-050-18	s	DIODE D4SBL20U
D601	6-500-407-01	s	DIODE SF20L60U-4015
D602	8-719-081-08	s	DIODE EP05Q04-TE8L3
D603	8-719-113-69	s	DIODE RD27ES-T1B
D604	8-719-063-73	s	DIODE D1NL20U-TR
D605	8-719-063-73	s	DIODE D1NL20U-TR
D606	8-719-069-63	s	DIODE ERB38-06V1
D608	8-719-921-20	s	DIODE 1SS119-25TD
D609	8-719-073-01	s	DIODE MA111-(K8).S0
D611	8-719-069-63	s	DIODE ERB38-06V1
D612	8-719-083-83	s	DIODE UDZS-TE17-15B
D613	8-719-082-03	s	DIODE MM3Z15VT1
D614	8-719-083-83	s	DIODE UDZS-TE17-15B
D615	8-719-082-03	s	DIODE MM3Z15VT1
D616	8-719-404-50	s	DIODE MA111-TX
D617	8-719-404-50	s	DIODE MA111-TX
D621	8-719-083-67	s	DIODE UDZSTE-1720B
D622	8-719-081-08	s	DIODE EP05Q04-TE8L3
D623	8-719-083-67	s	DIODE UDZSTE-1720B
D624	8-719-083-67	s	DIODE UDZSTE-1720B
D625	8-719-083-67	s	DIODE UDZSTE-1720B
D801	8-719-404-50	s	DIODE MA111-TX
D802	8-719-404-50	s	DIODE MA111-TX
D803	8-719-404-50	s	DIODE MA111-TX
D804	8-719-404-50	s	DIODE MA111-TX
D805	8-719-404-50	s	DIODE MA111-TX
D806	8-719-404-50	s	DIODE MA111-TX
D807	8-719-404-50	s	DIODE MA111-TX
D808	8-719-036-75	s	DIODE RD3.3SB1-T1
D901	8-719-404-50	s	DIODE MA111-TX
F1	△ 1-576-231-51	s	FUSE (H.B.C) (4A/250V)
FB101	1-410-396-51	s	FERRITE BEAD INDUCTOR 0.45UH
FB201	1-410-396-51	s	FERRITE BEAD INDUCTOR 0.45UH
FB202	1-410-396-51	s	FERRITE BEAD INDUCTOR 0.45UH
FB203	1-410-396-51	s	FERRITE BEAD INDUCTOR 0.45UH
FB204	1-410-396-51	s	FERRITE BEAD INDUCTOR 0.45UH
FB205	1-410-396-51	s	FERRITE BEAD INDUCTOR 0.45UH
FB206	1-410-396-51	s	FERRITE BEAD INDUCTOR 0.45UH
FH1	△ 1-533-701-11	o	HOLDER, FUSE
IC2	8-759-929-63	s	IC LM7815CT
IC102	8-749-011-42	s	IC SI-3050F
IC103	8-759-077-78	s	IC NJM79L05A-T3
IC104	8-759-189-04	s	IC UPC1093J-T
IC203	8-759-329-01	s	IC LM339NSR
IC601	6-704-815-01	s	IC FA5501N-TE1
IC602	8-759-535-32	s	IC FA13842P
IC603	6-705-810-01	s	IC MCZ3001DB
IC604	8-759-586-17	s	IC TL1431CZ-AP
IC801	8-759-189-04	s	IC UPC1093J-T
IC802	8-759-329-01	s	IC LM339NSR
L1	1-419-726-11	s	COIL, CHOKE 100UH
L002	△ 1-457-061-11	s	CHOKE COIL 430UH
L101	1-406-971-21	s	COIL, CHOKE 10UH
L201	1-406-659-21	s	COIL, CHOKE 10UH
L202	1-406-659-21	s	COIL, CHOKE 10UH

(G BOARD)

Ref. No. or Q'ty	Part No.	SP	Description
L203	1-406-971-21	s	COIL, CHOKE 10UH
L204	1-406-971-21	s	COIL, CHOKE 10UH
L205	1-406-659-21	s	COIL, CHOKE 10UH
PH101	△ 6-600-187-01	s	PHOTO COUPLER PC123Y22J00F
PH103	△ 6-600-187-01	s	PHOTO COUPLER PC123Y22J00F
PH201	△ 6-600-187-01	s	PHOTO COUPLER PC123Y22J00F
PH801	△ 6-600-187-01	s	PHOTO COUPLER PC123Y22J00F
PH901	△ 6-600-187-01	s	PHOTO COUPLER PC123Y22J00F
Q1	8-729-423-33	s	TRANSISTOR 2SC3311A-QRSTA
Q2	8-729-033-26	s	TRANSISTOR DTA114GKAT146
Q3	8-729-423-33	s	TRANSISTOR 2SC3311A-QRSTA
Q4	8-729-028-99	s	TRANSISTOR DTC114YUA-T106
Q5	8-729-029-47	s	TRANSISTOR DTA143ESA-TP
Q6	8-729-029-47	s	TRANSISTOR DTA143ESA-TP
Q7	8-729-028-91	s	TRANSISTOR DTA144EUA-T106
Q8	8-729-029-14	s	TRANSISTOR DTC144EUA-T106
Q9	8-729-028-91	s	TRANSISTOR DTA144EUA-T106
Q10	8-729-029-14	s	TRANSISTOR DTC144EUA-T106
Q101	8-729-033-24	s	TRANSISTOR DTC114GKAT146
Q102	8-729-027-38	s	TRANSISTOR DTA144EKA-T146
Q103	8-729-028-91	s	TRANSISTOR DTA144EUA-T106
Q601	6-550-372-01	s	TRANSISTOR SPA20N60C3E8152
Q602	8-729-045-03	s	TRANSISTOR 2SK2647-01MR-F91
Q603	6-550-372-01	s	TRANSISTOR SPA20N60C3E8152
Q604	6-550-372-01	s	TRANSISTOR SPA20N60C3E8152
Q605	8-729-820-92	s	TRANSISTOR 2SD1621ST-TD-E
Q606	8-729-805-35	s	TRANSISTOR 2SB1121-S-TD
Q607	8-729-031-03	s	TRANSISTOR 2PB709AR-115
Q608	8-729-031-03	s	TRANSISTOR 2PB709AR-115
Q609	8-729-028-73	s	TRANSISTOR DTA114EUA-T106
Q801	8-729-028-76	s	TRANSISTOR DTA114YUA-T106
Q802	8-729-029-14	s	TRANSISTOR DTC144EUA-T106
Q803	8-729-028-91	s	TRANSISTOR DTA144EUA-T106
Q804	8-729-029-14	s	TRANSISTOR DTC144EUA-T106
Q805	8-729-028-91	s	TRANSISTOR DTA144EUA-T106
Q806	8-729-029-14	s	TRANSISTOR DTC144EUA-T106
Q807	8-729-028-91	s	TRANSISTOR DTA144EUA-T106
Q808	8-729-029-14	s	TRANSISTOR DTC144EUA-T106
Q809	8-729-028-91	s	TRANSISTOR DTA144EUA-T106
Q810	8-729-029-14	s	TRANSISTOR DTC144EUA-T106
Q811	8-729-029-14	s	TRANSISTOR DTC144EUA-T106
Q812	8-729-029-14	s	TRANSISTOR DTC144EUA-T106
Q813	8-729-029-14	s	TRANSISTOR DTC144EUA-T106
Q814	8-729-029-14	s	TRANSISTOR DTC144EUA-T106
Q815	8-729-029-14	s	TRANSISTOR DTC144EUA-T106
Q901	8-729-028-99	s	TRANSISTOR DTC114YUA-T106
Q902	8-729-028-99	s	TRANSISTOR DTC114YUA-T106
Q903	8-729-028-99	s	TRANSISTOR DTC114YUA-T106
Q904	8-729-033-24	s	TRANSISTOR DTC114GKAT146
Q905	8-729-029-14	s	TRANSISTOR DTC144EUA-T106
R1	△ 1-220-825-91	s	RES, (SURGE RESISTANT) 330K
R2	△ 1-240-251-11	s	RES, CEMENT-COA 6.8
R3	1-216-841-91	s	RES, CHIP 47K (1608)
R4	1-216-837-91	s	RES, CHIP 22K (1608)
R5	1-216-821-91	s	RES, CHIP 1.0K (1608)
R6	1-216-834-91	s	RES, CHIP 12K (1608)
R7	1-260-085-81	s	RES, CARBON (SMALL TYPE) 68
R8	1-216-833-91	s	RES, CHIP 10K (1608)
R9	1-216-833-91	s	RES, CHIP 10K (1608)

(G BOARD)

Ref. No. or Q'ty	Part No.	SP Description
R10	1-216-837-91	s RES, CHIP 22K (1608)
R11	1-215-861-71	s RES, METAL OXIDE FILM 47
R15	1-249-405-91	s RES, CARBON (SMALL) 100
R16	1-215-861-71	s RES, METAL OXIDE FILM 47
R17	1-208-838-91	s RES, CHIP 220K (2012)
R18	1-208-838-91	s RES, CHIP 220K (2012)
R19	1-208-838-91	s RES, CHIP 220K (2012)
R20	1-208-838-91	s RES, CHIP 220K (2012)
R21	1-208-838-91	s RES, CHIP 220K (2012)
R22	1-208-840-91	s RES, CHIP 270K (2012)
R23	1-218-891-91	s RES, CHIP 68K (1608)
R101	1-211-769-71	s RES, FUSE 3.3
R105	1-216-835-91	s RES, CHIP 15K (1608)
R107	1-215-892-71	s RES, METAL OXIDE FILM 1K
R108	1-216-821-91	s RES, CHIP 1.0K (1608)
R109	1-216-821-91	s RES, CHIP 1.0K (1608)
R110	1-216-821-91	s RES, CHIP 1.0K (1608)
R111	1-218-831-91	s RES, CHIP 220 (1608)
R112	1-215-886-71	s RES, METAL OXIDE FILM 100
R113	1-216-825-91	s RES, CHIP 2.2K (1608)
R114	1-216-813-91	s RES, CHIP 220 (1608)
R116	1-218-857-91	s RES, CHIP 2.7K (1608)
R117	1-218-857-91	s RES, CHIP 2.7K (1608)
R118	1-219-718-11	s RES, CEMENT 0.1
R119	1-219-718-11	s RES, CEMENT 0.1
R120	1-219-718-11	s RES, CEMENT 0.1
R121	1-219-718-11	s RES, CEMENT 0.1
R122	1-216-797-91	s RES, CHIP 10 (1608)
R123	1-216-801-91	s RES, CHIP 22 (1608)
R124	1-216-825-91	s RES, CHIP 2.2K (1608)
R217	1-218-855-91	s RES, CHIP 2.2K (1608)
R218	1-218-873-91	s RES, CHIP 12K (1608)
R219	1-219-718-11	s RES, CEMENT 0.1
R220	1-218-855-91	s RES, CHIP 2.2K (1608)
R221	1-218-873-91	s RES, CHIP 12K (1608)
R223	1-218-861-91	s RES, CHIP 3.9K (1608)
R224	1-218-855-91	s RES, CHIP 2.2K (1608)
R225	1-219-718-11	s RES, CEMENT 0.1
R226	1-219-718-11	s RES, CEMENT 0.1
R227	1-218-855-91	s RES, CHIP 2.2K (1608)
R228	1-218-893-91	s RES, CHIP 82K (1608)
R229	1-218-861-91	s RES, CHIP 3.9K (1608)
R230	1-218-855-91	s RES, CHIP 2.2K (1608)
R231	1-218-861-91	s RES, CHIP 3.9K (1608)
R232	1-219-718-11	s RES, CEMENT 0.1
R233	1-219-718-11	s RES, CEMENT 0.1
R234	1-218-855-91	s RES, CHIP 2.2K (1608)
R235	1-218-893-91	s RES, CHIP 82K (1608)
R236	1-218-861-91	s RES, CHIP 3.9K (1608)
R237	1-219-718-11	s RES, CEMENT 0.1
R238	1-216-825-91	s RES, CHIP 2.2K (1608)
R239	1-216-821-91	s RES, CHIP 1.0K (1608)
R240	1-218-855-91	s RES, CHIP 2.2K (1608)
R241	1-218-873-91	s RES, CHIP 12K (1608)
R242	1-219-718-11	s RES, CEMENT 0.1
R243	1-218-855-91	s RES, CHIP 2.2K (1608)
R244	1-218-873-91	s RES, CHIP 12K (1608)
R246	1-220-778-81	s RES, NONFLAMMABLE FUSE 0.1
R247	1-220-778-81	s RES, NONFLAMMABLE FUSE 0.1
R601	1-245-482-21	s ANTI SURGE RESISTOR 680K

(G BOARD)

Ref. No. or Q'ty	Part No.	SP Description
R602	1-245-482-21	s ANTI SURGE RESISTOR 680K
R603	1-245-482-21	s ANTI SURGE RESISTOR 680K
R604	1-218-874-91	s RES, CHIP 13K (1608)
R605	1-216-845-91	s RES, CHIP 100K (1608)
R606	1-218-891-91	s RES, CHIP 68K (1608)
R607	1-247-815-91	s RES, CARBON (SMALL) 220
R608	1-216-803-91	s RES, CHIP 33 (1608)
R609	1-249-389-91	s RES, CARBON (SMALL) 4.7
R610	1-216-833-91	s RES, CHIP 10K (1608)
R611	1-219-728-11	s RES, CEMENT 0.22
R612	1-216-797-91	s RES, CHIP 10 (1608)
R613	1-215-901-71	s RES, METAL OXIDE FILM 33K
R614	1-260-360-71	s RES, CARBON 470K
R615	1-260-360-71	s RES, CARBON 470K
R616	1-216-831-91	s RES, CHIP 6.8K (1608)
R617	1-216-833-91	s RES, CHIP 10K (1608)
R618	1-218-867-91	s RES, CHIP 6.8K (1608)
R619	1-247-831-91	s RES, CARBON (SMALL) 1.0K
R620	1-243-662-71	s RES, METAL PLATE 1.0
R621	1-247-809-91	s RES, CARBON (SMALL) 120
R622	1-216-837-91	s RES, CHIP 22K (1608)
R623	1-216-833-91	s RES, CHIP 10K (1608)
R624	1-220-778-11	s RES, NONFLAMMABLE FUSE
R625	1-219-512-91	s RESISTOR(SURGE RESISTANT) 2.2M
R626	1-219-512-91	s RESISTOR(SURGE RESISTANT) 2.2M
R627	1-216-837-91	s RES, CHIP 22K (1608)
R628	1-218-899-91	s RES, CHIP 150K (1608)
R629	1-218-876-91	s RES, CHIP 16K (1608)
R630	1-218-286-91	s RES, CHIP 91 (1608)
R631	1-218-287-91	s RES, CHIP 200 (1608)
R632	1-218-847-91	s RES, CHIP 1.0K (1608)
R633	1-249-393-91	s RES, CARBON (SMALL) 10
R634	1-216-833-91	s RES, CHIP 10K (1608)
R635	1-249-393-91	s RES, CARBON (SMALL) 10
R636	1-216-833-91	s RES, CHIP 10K (1608)
R637	1-243-979-71	s RES, OXIDE METAL FILM 0.1
R638	1-219-728-11	s RES, CEMENT 0.22
R639	1-249-393-91	s RES, CARBON (SMALL) 10
R640	1-245-484-21	s ANTI SURGE RESISTOR 820K
R641	1-245-484-21	s ANTI SURGE RESISTOR 820K
R642	1-245-483-21	s ANTI SURGE RESISTOR 750K
R643	1-216-864-91	s CONDUCTOR, CHIP (1608)
R644	1-218-917-91	s RES, CHIP 820K (1608)
R645	1-218-876-91	s RES, CHIP 16K (1608)
R646	1-216-295-91	s CONDUCTOR, CHIP (2012)
R651	1-215-459-91	s RES, METAL FILM(SMALL TYPE)39K
R652	1-218-885-91	s RES, CHIP 39K (1608)
R653	1-218-885-91	s RES, CHIP 39K (1608)
R654	1-216-841-91	s RES, CHIP 47K (1608)
R655	1-218-855-91	s RES, CHIP 2.2K (1608)
R801	1-218-847-91	s RES, CHIP 1.0K (1608)
R802	1-218-873-91	s RES, CHIP 12K (1608)
R803	1-218-879-91	s RES, CHIP 22K (1608)
R804	1-216-829-91	s RES, CHIP 4.7K (1608)
R805	1-218-857-91	s RES, CHIP 2.7K (1608)
R806	1-218-853-91	s RES, CHIP 1.8K (1608)
R807	1-216-833-91	s RES, CHIP 10K (1608)
R808	1-218-879-91	s RES, CHIP 22K (1608)
R809	1-218-872-91	s RES, CHIP 11K (1608)
R810	1-218-863-91	s RES, CHIP 4.7K (1608)

(G BOARD)

Ref. No. or Q'ty	Part No.	SP Description
R811	1-218-855-91	s RES, CHIP 2.2K (1608)
R812	1-216-821-91	s RES, CHIP 1.0K (1608)
R813	1-216-833-91	s RES, CHIP 10K (1608)
R814	1-208-828-91	s RES, CHIP 82K (2012)
R815	1-208-828-91	s RES, CHIP 82K (2012)
R816	1-208-828-91	s RES, CHIP 82K (2012)
R817	1-218-855-91	s RES, CHIP 2.2K (1608)
R818	1-218-855-91	s RES, CHIP 2.2K (1608)
R819	1-218-849-91	s RES, CHIP 1.2K (1608)
R820	1-216-833-91	s RES, CHIP 10K (1608)
R821	1-216-833-91	s RES, CHIP 10K (1608)
R822	1-216-833-91	s RES, CHIP 10K (1608)
R823	1-216-833-91	s RES, CHIP 10K (1608)
R824	1-216-809-91	s RES, CHIP 100 (1608)
R825	1-216-809-91	s RES, CHIP 100 (1608)
R826	1-216-809-91	s RES, CHIP 100 (1608)
R827	1-216-809-91	s RES, CHIP 100 (1608)
R828	1-216-841-91	s RES, CHIP 47K (1608)
R829	1-216-837-91	s RES, CHIP 22K (1608)
R901	△ 1-219-513-91	s RESISTOR(SURGE RESISTANT) 4.7M
R902	△ 1-219-513-91	s RESISTOR(SURGE RESISTANT) 4.7M
R903	1-216-845-91	s RES, CHIP 100K (1608)
R904	1-216-815-91	s RES, CHIP 330 (1608)
R905	1-216-829-91	s RES, CHIP 4.7K (1608)
R906	1-216-833-91	s RES, CHIP 10K (1608)
R907	1-260-085-81	s RES, CARBON (SMALL TYPE) 68
RY1	△ 1-755-268-11	s RELAY, AC POWER
RY2	△ 1-755-018-11	s RELAY
SG1	1-533-982-21	s GAP, SPARK
T1	△ 1-435-180-11	s TRANSFORMER, LINE FILTER
T2	△ 1-435-180-11	s TRANSFORMER, LINE FILTER
T101	△ 1-435-184-11	s TRANSFORMER, CONVERTER (SRT)
T201	△ 1-443-676-21	s CONVERTER TRANSFORMER (PIT)
THP2	1-809-827-11	s THERMISTOR, POSITIVE
VDR2	△ 1-801-268-51	s VARISTOR TNR14V471K660
VDR3	△ 1-810-622-21	s VARISTOR

HA BOARD

Ref. No. or Q'ty	Part No.	SP Description
1pc	A-1133-995-A	s MOUNTED CIRCUIT BOARD, HA
C701	1-126-392-21	s CAP, CHIP ELECT 100MF(6.3X5.7)
C702	1-162-970-91	s CAP, CERAMIC 10000PF B 1608
C703	1-162-970-91	s CAP, CERAMIC 10000PF B 1608
C704	1-162-970-91	s CAP, CERAMIC 10000PF B 1608
C705	1-162-970-91	s CAP, CERAMIC 10000PF B 1608
C706	1-162-970-91	s CAP, CERAMIC 10000PF B 1608
C707	1-162-970-91	s CAP, CERAMIC 10000PF B 1608
C708	1-162-970-91	s CAP, CERAMIC 10000PF B 1608
C709	1-162-970-91	s CAP, CERAMIC 10000PF B 1608
C710	1-162-970-91	s CAP, CERAMIC 10000PF B 1608
C711	1-126-392-21	s CAP, CHIP ELECT 100MF(6.3X5.7)
C712	1-162-970-91	s CAP, CERAMIC 10000PF B 1608
C713	1-162-970-91	s CAP, CERAMIC 10000PF B 1608
C714	1-100-566-91	s CAP, CHIP CERAMIC 0.1MF B 1608
C715	1-126-392-21	s CAP, CHIP ELECT 100MF(6.3X5.7)
C716	1-126-392-21	s CAP, CHIP ELECT 100MF(6.3X5.7)
C717	1-162-966-91	s CAP, CERAMIC 2200PF B 1608
C721	1-126-392-21	s CAP, CHIP ELECT 100MF(6.3X5.7)
C731	1-100-566-91	s CAP, CHIP CERAMIC 0.1MF B 1608
C732	1-100-566-91	s CAP, CHIP CERAMIC 0.1MF B 1608
C733	1-100-566-91	s CAP, CHIP CERAMIC 0.1MF B 1608
C734	1-100-566-91	s CAP, CHIP CERAMIC 0.1MF B 1608
C735	1-100-566-91	s CAP, CHIP CERAMIC 0.1MF B 1608
C736	1-100-566-91	s CAP, CHIP CERAMIC 0.1MF B 1608
C737	1-100-566-91	s CAP, CHIP CERAMIC 0.1MF B 1608
C738	1-100-566-91	s CAP, CHIP CERAMIC 0.1MF B 1608
C741	1-126-392-21	s CAP, CHIP ELECT 100MF(6.3X5.7)
C742	1-126-392-21	s CAP, CHIP ELECT 100MF(6.3X5.7)
C743	1-162-970-91	s CAP, CERAMIC 10000PF B 1608
C744	1-162-970-91	s CAP, CERAMIC 10000PF B 1608
C745	1-100-566-91	s CAP, CHIP CERAMIC 0.1MF B 1608
C751	1-100-566-91	s CAP, CHIP CERAMIC 0.1MF B 1608
C761	1-100-566-91	s CAP, CHIP CERAMIC 0.1MF B 1608
C762	1-100-566-91	s CAP, CHIP CERAMIC 0.1MF B 1608
C763	1-100-566-91	s CAP, CHIP CERAMIC 0.1MF B 1608
C764	1-100-566-91	s CAP, CHIP CERAMIC 0.1MF B 1608
C765	1-100-566-91	s CAP, CHIP CERAMIC 0.1MF B 1608
C766	1-100-566-91	s CAP, CHIP CERAMIC 0.1MF B 1608
C767	1-100-566-91	s CAP, CHIP CERAMIC 0.1MF B 1608
C768	1-100-566-91	s CAP, CHIP CERAMIC 0.1MF B 1608
C769	1-100-566-91	s CAP, CHIP CERAMIC 0.1MF B 1608
C770	1-100-566-91	s CAP, CHIP CERAMIC 0.1MF B 1608
C771	1-100-566-91	s CAP, CHIP CERAMIC 0.1MF B 1608
C772	1-100-566-91	s CAP, CHIP CERAMIC 0.1MF B 1608
C773	1-100-566-91	s CAP, CHIP CERAMIC 0.1MF B 1608
C774	1-100-566-91	s CAP, CHIP CERAMIC 0.1MF B 1608
C775	1-100-566-91	s CAP, CHIP CERAMIC 0.1MF B 1608
C776	1-100-566-91	s CAP, CHIP CERAMIC 0.1MF B 1608
C777	1-100-566-91	s CAP, CHIP CERAMIC 0.1MF B 1608
C778	1-100-566-91	s CAP, CHIP CERAMIC 0.1MF B 1608
C779	1-100-566-91	s CAP, CHIP CERAMIC 0.1MF B 1608
C780	1-100-566-91	s CAP, CHIP CERAMIC 0.1MF B 1608
C781	1-100-566-91	s CAP, CHIP CERAMIC 0.1MF B 1608
C782	1-100-566-91	s CAP, CHIP CERAMIC 0.1MF B 1608
C783	1-100-566-91	s CAP, CHIP CERAMIC 0.1MF B 1608
C784	1-100-566-91	s CAP, CHIP CERAMIC 0.1MF B 1608
C785	1-100-566-91	s CAP, CHIP CERAMIC 0.1MF B 1608

(HA BOARD)

Ref. No. or Q'ty	Part No.	SP Description
C786	1-162-970-91	s CAP, CERAMIC 10000PF B 1608
CN701	1-764-080-21	o PIN, CONNECTOR (PC BOARD) 8P
CN702	1-764-087-21	s PIN, CONNECTOR (PC BOARD) 14P
D701	8-719-038-07	s DIODE CL-190PG-CD-T
D702	8-719-038-07	s DIODE CL-190PG-CD-T
D703	8-719-038-07	s DIODE CL-190PG-CD-T
D704	8-719-038-07	s DIODE CL-190PG-CD-T
D705	8-719-036-80	s DIODE RD3.9SB-T1
D706	8-719-036-80	s DIODE RD3.9SB-T1
D707	8-719-036-80	s DIODE RD3.9SB-T1
D708	8-719-036-80	s DIODE RD3.9SB-T1
D709	8-719-036-80	s DIODE RD3.9SB-T1
D710	8-719-036-80	s DIODE RD3.9SB-T1
D711	8-719-036-80	s DIODE RD3.9SB-T1
D712	8-719-036-80	s DIODE RD3.9SB-T1
D713	8-719-036-80	s DIODE RD3.9SB-T1
D714	8-719-036-80	s DIODE RD3.9SB-T1
D715	8-719-036-80	s DIODE RD3.9SB-T1
D716	8-719-036-80	s DIODE RD3.9SB-T1
D717	8-719-036-80	s DIODE RD3.9SB-T1
D718	8-719-036-80	s DIODE RD3.9SB-T1
D719	8-719-036-80	s DIODE RD3.9SB-T1
D720	8-719-036-80	s DIODE RD3.9SB-T1
D721	8-719-036-80	s DIODE RD3.9SB-T1
D722	8-719-036-80	s DIODE RD3.9SB-T1
D723	8-719-036-80	s DIODE RD3.9SB-T1
D724	8-719-036-80	s DIODE RD3.9SB-T1
D725	8-719-036-80	s DIODE RD3.9SB-T1
D726	8-719-036-80	s DIODE RD3.9SB-T1
D727	8-719-036-80	s DIODE RD3.9SB-T1
D728	8-719-036-80	s DIODE RD3.9SB-T1
D729	8-719-036-80	s DIODE RD3.9SB-T1
D730	8-719-036-80	s DIODE RD3.9SB-T1
D731	8-719-036-80	s DIODE RD3.9SB-T1
D732	8-719-036-80	s DIODE RD3.9SB-T1
D733	8-719-036-80	s DIODE RD3.9SB-T1
D734	8-719-036-80	s DIODE RD3.9SB-T1
D735	8-719-036-80	s DIODE RD3.9SB-T1
D736	8-719-036-80	s DIODE RD3.9SB-T1
D737	8-719-036-80	s DIODE RD3.9SB-T1
D738	8-719-036-80	s DIODE RD3.9SB-T1
D739	8-719-036-80	s DIODE RD3.9SB-T1
D740	8-719-036-80	s DIODE RD3.9SB-T1
D741	8-719-036-80	s DIODE RD3.9SB-T1
D742	8-719-036-80	s DIODE RD3.9SB-T1
D743	8-719-036-80	s DIODE RD3.9SB-T1
D744	8-719-036-80	s DIODE RD3.9SB-T1
D745	8-719-036-80	s DIODE RD3.9SB-T1
D746	8-719-036-98	s DIODE RD6.2SB-T1
FB701	1-414-864-21	s FERRITE, EMI (SMD) (1608)
FB702	1-414-864-21	s FERRITE, EMI (SMD) (1608)
FB703	1-414-864-21	s FERRITE, EMI (SMD) (1608)
FB704	1-414-864-21	s FERRITE, EMI (SMD) (1608)
IC701	6-709-437-01	s IC LC4256V-75TN100CA1353
IC702	8-759-573-97	s IC SN74LVCS41APWR
IC703	8-759-523-84	s IC TC74VHC14FT(EL)
IC704	8-759-523-84	s IC TC74VHC14FT(EL)

(HA BOARD)

Ref. No. or Q'ty	Part No.	SP Description
IC705	6-708-748-01	s IC BD4828FVE-TR
Q701	8-729-029-04	s TRANSISTOR DTC123JUA-T106
Q702	8-729-029-04	s TRANSISTOR DTC123JUA-T106
Q703	8-729-029-04	s TRANSISTOR DTC123JUA-T106
Q704	8-729-029-04	s TRANSISTOR DTC123JUA-T106
R699	1-216-801-91	s RES, CHIP 22 (1608)
R700	1-216-825-91	s RES, CHIP 2.2K (1608)
R701	1-216-825-91	s RES, CHIP 2.2K (1608)
R702	1-216-825-91	s RES, CHIP 2.2K (1608)
R703	1-216-825-91	s RES, CHIP 2.2K (1608)
R704	1-216-825-91	s RES, CHIP 2.2K (1608)
R705	1-216-825-91	s RES, CHIP 2.2K (1608)
R706	1-216-825-91	s RES, CHIP 2.2K (1608)
R707	1-216-825-91	s RES, CHIP 2.2K (1608)
R708	1-216-825-91	s RES, CHIP 2.2K (1608)
R709	1-216-825-91	s RES, CHIP 2.2K (1608)
R710	1-216-825-91	s RES, CHIP 2.2K (1608)
R711	1-216-825-91	s RES, CHIP 2.2K (1608)
R712	1-216-825-91	s RES, CHIP 2.2K (1608)
R713	1-216-825-91	s RES, CHIP 2.2K (1608)
R714	1-216-825-91	s RES, CHIP 2.2K (1608)
R715	1-216-825-91	s RES, CHIP 2.2K (1608)
R716	1-216-825-91	s RES, CHIP 2.2K (1608)
R717	1-216-825-91	s RES, CHIP 2.2K (1608)
R718	1-216-825-91	s RES, CHIP 2.2K (1608)
R719	1-216-825-91	s RES, CHIP 2.2K (1608)
R720	1-216-825-91	s RES, CHIP 2.2K (1608)
R721	1-216-825-91	s RES, CHIP 2.2K (1608)
R722	1-216-825-91	s RES, CHIP 2.2K (1608)
R723	1-216-825-91	s RES, CHIP 2.2K (1608)
R724	1-216-825-91	s RES, CHIP 2.2K (1608)
R725	1-216-825-91	s RES, CHIP 2.2K (1608)
R726	1-216-801-91	s RES, CHIP 22 (1608)
R727	1-216-829-91	s RES, CHIP 4.7K (1608)
R728	1-216-833-91	s RES, CHIP 10K (1608)
R729	1-216-825-91	s RES, CHIP 2.2K (1608)
R730	1-216-825-91	s RES, CHIP 2.2K (1608)
R731	1-216-833-91	s RES, CHIP 10K (1608)
R732	1-216-833-91	s RES, CHIP 10K (1608)
R733	1-216-833-91	s RES, CHIP 10K (1608)
R734	1-216-833-91	s RES, CHIP 10K (1608)
R735	1-216-833-91	s RES, CHIP 10K (1608)
R736	1-216-833-91	s RES, CHIP 10K (1608)
R737	1-216-833-91	s RES, CHIP 10K (1608)
R738	1-216-833-91	s RES, CHIP 10K (1608)
R739	1-216-833-91	s RES, CHIP 10K (1608)
R740	1-216-833-91	s RES, CHIP 10K (1608)
R741	1-216-833-91	s RES, CHIP 10K (1608)
R742	1-216-833-91	s RES, CHIP 10K (1608)
R743	1-216-833-91	s RES, CHIP 10K (1608)
R744	1-216-833-91	s RES, CHIP 10K (1608)
R745	1-216-833-91	s RES, CHIP 10K (1608)
R746	1-216-833-91	s RES, CHIP 10K (1608)
R747	1-216-825-91	s RES, CHIP 2.2K (1608)
R748	1-216-825-91	s RES, CHIP 2.2K (1608)
R749	1-216-825-91	s RES, CHIP 2.2K (1608)
R750	1-216-825-91	s RES, CHIP 2.2K (1608)
R751	1-216-813-91	s RES, CHIP 220 (1608)

(HA BOARD)

Ref. No. or Q'ty	Part No.	SP Description
R752	1-216-813-91	s RES, CHIP 220 (1608)
R753	1-216-813-91	s RES, CHIP 220 (1608)
R754	1-216-813-91	s RES, CHIP 220 (1608)
R755	1-216-864-91	s CONDUCTOR, CHIP (1608)
R756	1-216-864-91	s CONDUCTOR, CHIP (1608)
R757	1-216-864-91	s CONDUCTOR, CHIP (1608)
R758	1-216-864-91	s CONDUCTOR, CHIP (1608)
R759	1-216-864-91	s CONDUCTOR, CHIP (1608)
R760	1-216-864-91	s CONDUCTOR, CHIP (1608)
R761	1-216-829-91	s RES, CHIP 4.7K (1608)
R762	1-216-833-91	s RES, CHIP 10K (1608)
R763	1-216-829-91	s RES, CHIP 4.7K (1608)
R764	1-216-829-91	s RES, CHIP 4.7K (1608)
R765	1-216-864-91	s CONDUCTOR, CHIP (1608)
R766	1-216-864-91	s CONDUCTOR, CHIP (1608)
R767	1-216-864-91	s CONDUCTOR, CHIP (1608)
R768	1-216-864-91	s CONDUCTOR, CHIP (1608)
R769	1-216-864-91	s CONDUCTOR, CHIP (1608)
R770	1-216-864-91	s CONDUCTOR, CHIP (1608)
R772	1-216-864-91	s CONDUCTOR, CHIP (1608)
R773	1-216-864-91	s CONDUCTOR, CHIP (1608)
R774	1-216-825-91	s RES, CHIP 2.2K (1608)
R775	1-216-825-91	s RES, CHIP 2.2K (1608)
R776	1-216-825-91	s RES, CHIP 2.2K (1608)
R777	1-216-825-91	s RES, CHIP 2.2K (1608)
R778	1-216-825-91	s RES, CHIP 2.2K (1608)
R779	1-216-825-91	s RES, CHIP 2.2K (1608)
R780	1-216-825-91	s RES, CHIP 2.2K (1608)
R781	1-216-825-91	s RES, CHIP 2.2K (1608)
R782	1-216-825-91	s RES, CHIP 2.2K (1608)
R783	1-216-825-91	s RES, CHIP 2.2K (1608)
R784	1-216-825-91	s RES, CHIP 2.2K (1608)
R785	1-216-825-91	s RES, CHIP 2.2K (1608)
R786	1-216-825-91	s RES, CHIP 2.2K (1608)
R787	1-216-825-91	s RES, CHIP 2.2K (1608)
R788	1-216-825-91	s RES, CHIP 2.2K (1608)
R789	1-216-825-91	s RES, CHIP 2.2K (1608)
R790	1-216-825-91	s RES, CHIP 2.2K (1608)
R791	1-216-825-91	s RES, CHIP 2.2K (1608)
R792	1-216-825-91	s RES, CHIP 2.2K (1608)
R794	1-216-825-91	s RES, CHIP 2.2K (1608)
R795	1-216-825-91	s RES, CHIP 2.2K (1608)
R796	1-216-825-91	s RES, CHIP 2.2K (1608)
R797	1-216-825-91	s RES, CHIP 2.2K (1608)
R798	1-216-825-91	s RES, CHIP 2.2K (1608)
R799	1-216-825-91	s RES, CHIP 2.2K (1608)
R800	1-216-825-91	s RES, CHIP 2.2K (1608)
R950	1-216-829-91	s RES, CHIP 4.7K (1608)
RB702	1-234-370-21	s RES, NETWORK 22 (1005X4)
RB703	1-234-370-21	s RES, NETWORK 22 (1005X4)
RB704	1-234-370-21	s RES, NETWORK 22 (1005X4)
RB705	1-234-370-21	s RES, NETWORK 22 (1005X4)
S701	1-762-357-21	s SWITCH
S702	1-762-357-21	s SWITCH
S703	1-762-357-21	s SWITCH
S704	1-762-357-21	s SWITCH
S705	1-762-357-21	s SWITCH
S706	1-762-357-21	s SWITCH

(HA BOARD)

Ref. No. or Q'ty	Part No.	SP Description
S707	1-762-357-21	s SWITCH
S708	1-762-357-21	s SWITCH
S709	1-762-357-21	s SWITCH
S710	1-762-357-21	s SWITCH
S711	1-762-357-21	s SWITCH
S712	1-762-357-21	s SWITCH
S713	1-762-357-21	s SWITCH
S714	1-762-357-21	s SWITCH
S715	1-762-357-21	s SWITCH
S716	1-762-357-21	s SWITCH
S717	1-762-357-21	s SWITCH
S718	1-762-357-21	s SWITCH
S719	1-762-357-21	s SWITCH
S720	1-762-357-21	s SWITCH
S721	1-762-357-21	s SWITCH
S722	1-762-357-21	s SWITCH
S723	1-762-357-21	s SWITCH
S724	1-762-357-21	s SWITCH
S725	1-762-357-21	s SWITCH
S731	1-473-469-11	s ENCODER, ROTARY
S732	1-473-469-11	s ENCODER, ROTARY
S733	1-473-469-11	s ENCODER, ROTARY
S734	1-473-469-11	s ENCODER, ROTARY

 HB BOARD

Ref. No. or Q'ty	Part No.	SP Description
1pc	A-1133-996-A	s MOUNTED CIRCUIT BOARD, HB
C801	1-100-055-11	s CAP, CHIP CERAMIC 22MF B 3225
C802	1-162-970-91	s CAP, CERAMIC 10000PF B 1608
C803	1-162-970-91	s CAP, CERAMIC 10000PF B 1608
C804	1-162-970-91	s CAP, CERAMIC 10000PF B 1608
C805	1-162-970-91	s CAP, CERAMIC 10000PF B 1608
C806	1-162-970-91	s CAP, CERAMIC 10000PF B 1608
C807	1-162-970-91	s CAP, CERAMIC 10000PF B 1608
C808	1-162-970-91	s CAP, CERAMIC 10000PF B 1608
C809	1-162-970-91	s CAP, CERAMIC 10000PF B 1608
C810	1-162-970-91	s CAP, CERAMIC 10000PF B 1608
C811	1-100-055-11	s CAP, CHIP CERAMIC 22MF B 3225
C812	1-100-566-91	s CAP, CHIP CERAMIC 0.1MF B 1608
C813	1-162-970-91	s CAP, CERAMIC 10000PF B 1608
C814	1-100-566-91	s CAP, CHIP CERAMIC 0.1MF B 1608
C815	1-100-055-11	s CAP, CHIP CERAMIC 22MF B 3225
C816	1-100-055-11	s CAP, CHIP CERAMIC 22MF B 3225
C817	1-100-055-11	s CAP, CHIP CERAMIC 22MF B 3225
C821	1-100-055-11	s CAP, CHIP CERAMIC 22MF B 3225
C822	1-100-566-91	s CAP, CHIP CERAMIC 0.1MF B 1608
C823	1-100-566-91	s CAP, CHIP CERAMIC 0.1MF B 1608
C824	1-100-055-11	s CAP, CHIP CERAMIC 22MF B 3225
C825	1-100-566-91	s CAP, CHIP CERAMIC 0.1MF B 1608
C831	1-100-055-11	s CAP, CHIP CERAMIC 22MF B 3225
C832	1-162-970-91	s CAP, CERAMIC 10000PF B 1608
C841	1-100-566-91	s CAP, CHIP CERAMIC 0.1MF B 1608
C842	1-100-566-91	s CAP, CHIP CERAMIC 0.1MF B 1608
C843	1-100-566-91	s CAP, CHIP CERAMIC 0.1MF B 1608
C844	1-100-566-91	s CAP, CHIP CERAMIC 0.1MF B 1608
C845	1-100-566-91	s CAP, CHIP CERAMIC 0.1MF B 1608
C846	1-100-566-91	s CAP, CHIP CERAMIC 0.1MF B 1608
C847	1-100-566-91	s CAP, CHIP CERAMIC 0.1MF B 1608
C848	1-100-566-91	s CAP, CHIP CERAMIC 0.1MF B 1608
C849	1-100-566-91	s CAP, CHIP CERAMIC 0.1MF B 1608
C850	1-100-566-91	s CAP, CHIP CERAMIC 0.1MF B 1608
C851	1-100-566-91	s CAP, CHIP CERAMIC 0.1MF B 1608
C852	1-100-566-91	s CAP, CHIP CERAMIC 0.1MF B 1608
C853	1-100-566-91	s CAP, CHIP CERAMIC 0.1MF B 1608
C854	1-100-566-91	s CAP, CHIP CERAMIC 0.1MF B 1608
C855	1-100-566-91	s CAP, CHIP CERAMIC 0.1MF B 1608
C856	1-100-566-91	s CAP, CHIP CERAMIC 0.1MF B 1608
C857	1-100-566-91	s CAP, CHIP CERAMIC 0.1MF B 1608
C858	1-162-970-91	s CAP, CERAMIC 10000PF B 1608
C860	1-162-966-91	s CAP, CERAMIC 2200PF B 1608
CN801	1-764-080-21	o PIN, CONNECTOR (PC BOARD) 8P
CN802	1-695-209-21	s PIN, CONNECTOR (PC BOARD) 15P
D801	8-719-038-07	s DIODE CL-190PG-CD-T
D802	8-719-038-07	s DIODE CL-190PG-CD-T
D803	8-719-038-07	s DIODE CL-190PG-CD-T
D804	8-719-038-07	s DIODE CL-190PG-CD-T
D805	8-719-038-07	s DIODE CL-190PG-CD-T
D806	8-719-038-07	s DIODE CL-190PG-CD-T
D807	8-719-038-07	s DIODE CL-190PG-CD-T
D808	8-719-038-07	s DIODE CL-190PG-CD-T
D809	8-719-038-07	s DIODE CL-190PG-CD-T
D810	8-719-038-07	s DIODE CL-190PG-CD-T
D811	8-719-038-07	s DIODE CL-190PG-CD-T

(HB BOARD)

Ref. No. or Q'ty	Part No.	SP Description
D812	8-719-038-07	s DIODE CL-190PG-CD-T
D813	8-719-038-07	s DIODE CL-190PG-CD-T
D814	8-719-038-07	s DIODE CL-190PG-CD-T
D815	8-719-038-07	s DIODE CL-190PG-CD-T
D816	8-719-038-07	s DIODE CL-190PG-CD-T
D821	8-719-036-80	s DIODE RD3.9SB-T1
D822	8-719-036-80	s DIODE RD3.9SB-T1
D823	8-719-036-80	s DIODE RD3.9SB-T1
D824	8-719-036-80	s DIODE RD3.9SB-T1
D825	8-719-036-80	s DIODE RD3.9SB-T1
D826	8-719-036-80	s DIODE RD3.9SB-T1
D827	8-719-036-80	s DIODE RD3.9SB-T1
D828	8-719-036-80	s DIODE RD3.9SB-T1
D829	8-719-036-80	s DIODE RD3.9SB-T1
D830	8-719-036-80	s DIODE RD3.9SB-T1
D831	8-719-036-80	s DIODE RD3.9SB-T1
D832	8-719-036-80	s DIODE RD3.9SB-T1
D833	8-719-036-80	s DIODE RD3.9SB-T1
D834	8-719-036-80	s DIODE RD3.9SB-T1
D835	8-719-036-80	s DIODE RD3.9SB-T1
D836	8-719-036-80	s DIODE RD3.9SB-T1
D837	8-719-036-80	s DIODE RD3.9SB-T1
D841	8-719-036-80	s DIODE RD3.9SB-T1
D842	8-719-036-80	s DIODE RD3.9SB-T1
D843	8-719-036-80	s DIODE RD3.9SB-T1
D844	8-719-036-80	s DIODE RD3.9SB-T1
D845	8-719-036-80	s DIODE RD3.9SB-T1
D846	8-719-036-80	s DIODE RD3.9SB-T1
D847	8-719-036-80	s DIODE RD3.9SB-T1
D848	8-719-036-80	s DIODE RD3.9SB-T1
D849	8-719-036-80	s DIODE RD3.9SB-T1
D850	8-719-036-80	s DIODE RD3.9SB-T1
D851	8-719-036-80	s DIODE RD3.9SB-T1
D852	8-719-036-80	s DIODE RD3.9SB-T1
D853	8-719-036-80	s DIODE RD3.9SB-T1
D854	8-719-036-80	s DIODE RD3.9SB-T1
D855	8-719-036-80	s DIODE RD3.9SB-T1
D856	8-719-036-80	s DIODE RD3.9SB-T1
D857	8-719-036-80	s DIODE RD3.9SB-T1
D866	8-719-036-80	s DIODE RD3.9SB-T1
D867	8-719-036-80	s DIODE RD3.9SB-T1
D868	8-719-036-80	s DIODE RD3.9SB-T1
D869	8-719-036-98	s DIODE RD6.2SB-T1
D870	8-719-036-80	s DIODE RD3.9SB-T1
D871	8-719-036-80	s DIODE RD3.9SB-T1
D872	8-719-036-80	s DIODE RD3.9SB-T1
D873	8-719-036-80	s DIODE RD3.9SB-T1
D874	8-719-036-80	s DIODE RD3.9SB-T1
D875	8-719-036-80	s DIODE RD3.9SB-T1
D876	8-719-036-80	s DIODE RD3.9SB-T1
FB801	1-414-864-21	s FERRITE, EMI (SMD) (1608)
FB802	1-414-864-21	s FERRITE, EMI (SMD) (1608)
FB803	1-414-864-21	s FERRITE, EMI (SMD) (1608)
FB804	1-414-864-21	s FERRITE, EMI (SMD) (1608)
IC801	6-708-834-01	s IC LC4128V-75TN100CA1353
IC802	8-759-099-44	s IC TD62381FG(EL)
IC803	8-759-099-44	s IC TD62381FG(EL)
IC804	8-759-573-97	s IC SN74LVC541APWR
IC805	6-708-748-01	s IC BD4828FVE-TR

(HB BOARD)

Ref. No. or Q'ty	Part No.	SP	Description
IC806	6-706-488-01	s	IC TC7SH14FU(T5RSOYJF)
R801	1-216-825-91	s	RES, CHIP 2.2K (1608)
R802	1-216-825-91	s	RES, CHIP 2.2K (1608)
R803	1-216-825-91	s	RES, CHIP 2.2K (1608)
R804	1-216-825-91	s	RES, CHIP 2.2K (1608)
R805	1-216-825-91	s	RES, CHIP 2.2K (1608)
R806	1-216-825-91	s	RES, CHIP 2.2K (1608)
R807	1-216-825-91	s	RES, CHIP 2.2K (1608)
R808	1-216-825-91	s	RES, CHIP 2.2K (1608)
R809	1-216-825-91	s	RES, CHIP 2.2K (1608)
R810	1-216-825-91	s	RES, CHIP 2.2K (1608)
R811	1-216-825-91	s	RES, CHIP 2.2K (1608)
R812	1-216-825-91	s	RES, CHIP 2.2K (1608)
R813	1-216-825-91	s	RES, CHIP 2.2K (1608)
R814	1-216-825-91	s	RES, CHIP 2.2K (1608)
R815	1-216-825-91	s	RES, CHIP 2.2K (1608)
R816	1-216-825-91	s	RES, CHIP 2.2K (1608)
R817	1-216-801-91	s	RES, CHIP 22 (1608)
R818	1-216-829-91	s	RES, CHIP 4.7K (1608)
R819	1-216-833-91	s	RES, CHIP 10K (1608)
R821	1-216-813-91	s	RES, CHIP 220 (1608)
R822	1-216-813-91	s	RES, CHIP 220 (1608)
R823	1-216-813-91	s	RES, CHIP 220 (1608)
R824	1-216-813-91	s	RES, CHIP 220 (1608)
R825	1-216-813-91	s	RES, CHIP 220 (1608)
R826	1-216-813-91	s	RES, CHIP 220 (1608)
R827	1-216-813-91	s	RES, CHIP 220 (1608)
R828	1-216-813-91	s	RES, CHIP 220 (1608)
R829	1-216-813-91	s	RES, CHIP 220 (1608)
R830	1-216-813-91	s	RES, CHIP 220 (1608)
R831	1-216-813-91	s	RES, CHIP 220 (1608)
R832	1-216-813-91	s	RES, CHIP 220 (1608)
R833	1-216-813-91	s	RES, CHIP 220 (1608)
R834	1-216-813-91	s	RES, CHIP 220 (1608)
R835	1-216-813-91	s	RES, CHIP 220 (1608)
R836	1-216-813-91	s	RES, CHIP 220 (1608)
R841	1-216-829-91	s	RES, CHIP 4.7K (1608)
R842	1-216-833-91	s	RES, CHIP 10K (1608)
R843	1-216-833-91	s	RES, CHIP 10K (1608)
R844	1-216-833-91	s	RES, CHIP 10K (1608)
R852	1-216-833-91	s	RES, CHIP 10K (1608)
R866	1-216-864-91	s	CONDUCTOR, CHIP (1608)
R867	1-216-864-91	s	CONDUCTOR, CHIP (1608)
R868	1-216-864-91	s	CONDUCTOR, CHIP (1608)
R869	1-216-864-91	s	CONDUCTOR, CHIP (1608)
R870	1-216-864-91	s	CONDUCTOR, CHIP (1608)
R871	1-216-864-91	s	CONDUCTOR, CHIP (1608)
R872	1-216-864-91	s	CONDUCTOR, CHIP (1608)
R873	1-216-864-91	s	CONDUCTOR, CHIP (1608)
R874	1-216-864-91	s	CONDUCTOR, CHIP (1608)
R875	1-216-864-91	s	CONDUCTOR, CHIP (1608)
R876	1-216-864-91	s	CONDUCTOR, CHIP (1608)
R877	1-216-821-91	s	RES, CHIP 1.0K (1608)
R878	1-216-821-91	s	RES, CHIP 1.0K (1608)
R879	1-216-821-91	s	RES, CHIP 1.0K (1608)
R880	1-216-821-91	s	RES, CHIP 1.0K (1608)
R881	1-216-821-91	s	RES, CHIP 1.0K (1608)
R882	1-216-821-91	s	RES, CHIP 1.0K (1608)

(HB BOARD)

Ref. No. or Q'ty	Part No.	SP	Description
R883	1-216-821-91	s	RES, CHIP 1.0K (1608)
R884	1-216-821-91	s	RES, CHIP 1.0K (1608)
R885	1-216-821-91	s	RES, CHIP 1.0K (1608)
R886	1-216-821-91	s	RES, CHIP 1.0K (1608)
R887	1-216-821-91	s	RES, CHIP 1.0K (1608)
R888	1-216-821-91	s	RES, CHIP 1.0K (1608)
R889	1-216-821-91	s	RES, CHIP 1.0K (1608)
R890	1-216-821-91	s	RES, CHIP 1.0K (1608)
R891	1-216-821-91	s	RES, CHIP 1.0K (1608)
R892	1-216-821-91	s	RES, CHIP 1.0K (1608)
R893	1-216-821-91	s	RES, CHIP 1.0K (1608)
R894	1-216-821-91	s	RES, CHIP 1.0K (1608)
R895	1-216-821-91	s	RES, CHIP 1.0K (1608)
R896	1-216-821-91	s	RES, CHIP 1.0K (1608)
R897	1-216-821-91	s	RES, CHIP 1.0K (1608)
R898	1-216-821-91	s	RES, CHIP 1.0K (1608)
R899	1-216-821-91	s	RES, CHIP 1.0K (1608)
R900	1-216-821-91	s	RES, CHIP 1.0K (1608)
R901	1-216-821-91	s	RES, CHIP 1.0K (1608)
R902	1-216-821-91	s	RES, CHIP 1.0K (1608)
R903	1-216-821-91	s	RES, CHIP 1.0K (1608)
R904	1-216-821-91	s	RES, CHIP 1.0K (1608)
R905	1-216-821-91	s	RES, CHIP 1.0K (1608)
R906	1-216-821-91	s	RES, CHIP 1.0K (1608)
R907	1-216-821-91	s	RES, CHIP 1.0K (1608)
R908	1-216-821-91	s	RES, CHIP 1.0K (1608)
R909	1-216-829-91	s	RES, CHIP 4.7K (1608)
RB802	1-234-370-21	s	RES, NETWORK 22 (1005X4)
RB803	1-234-370-21	s	RES, NETWORK 22 (1005X4)
RB804	1-234-370-21	s	RES, NETWORK 22 (1005X4)
RB805	1-234-370-21	s	RES, NETWORK 22 (1005X4)
S801	1-762-400-21	s	SWITCH
S802	1-762-400-21	s	SWITCH
S803	1-762-400-21	s	SWITCH
S804	1-762-400-21	s	SWITCH
S805	1-762-400-21	s	SWITCH
S806	1-762-400-21	s	SWITCH
S807	1-762-400-21	s	SWITCH
S808	1-762-400-21	s	SWITCH
S809	1-762-400-21	s	SWITCH
S810	1-762-400-21	s	SWITCH
S811	1-762-400-21	s	SWITCH
S812	1-762-400-21	s	SWITCH
S813	1-762-400-21	s	SWITCH
S814	1-762-400-21	s	SWITCH
S815	1-762-400-21	s	SWITCH
S816	1-762-400-21	s	SWITCH

 HC BOARD

Ref. No. or Q'ty	Part No.	SP Description
1pc	A-1091-403-A	s MOUNTED CIRCUIT BOARD, HC
3pcs	4-042-408-02	o PIN (45), WIRE (CLP101,102,103)
C151	1-100-566-91	s CAP, CHIP CERAMIC 0.1MF B 1608
C152	1-100-566-91	s CAP, CHIP CERAMIC 0.1MF B 1608
C153	1-100-566-91	s CAP, CHIP CERAMIC 0.1MF B 1608
C154	1-100-566-91	s CAP, CHIP CERAMIC 0.1MF B 1608
C156	1-100-566-91	s CAP, CHIP CERAMIC 0.1MF B 1608
C157	1-100-566-91	s CAP, CHIP CERAMIC 0.1MF B 1608
C158	1-100-566-91	s CAP, CHIP CERAMIC 0.1MF B 1608
C159	1-131-661-21	s CAP, CHIP ELECT 100MF(6.3X5.7)
C160	1-100-566-91	s CAP, CHIP CERAMIC 0.1MF B 1608
C161	1-100-566-91	s CAP, CHIP CERAMIC 0.1MF B 1608
C162	1-126-392-21	s CAP, CHIP ELECT 100MF(6.3X5.7)
C163	1-126-392-21	s CAP, CHIP ELECT 100MF(6.3X5.7)
C164	1-100-566-91	s CAP, CHIP CERAMIC 0.1MF B 1608
C165	1-100-566-91	s CAP, CHIP CERAMIC 0.1MF B 1608
C168	1-126-392-21	s CAP, CHIP ELECT 100MF(6.3X5.7)
C169	1-100-566-91	s CAP, CHIP CERAMIC 0.1MF B 1608
C170	1-126-392-21	s CAP, CHIP ELECT 100MF(6.3X5.7)
C171	1-100-566-91	s CAP, CHIP CERAMIC 0.1MF B 1608
C172	1-126-392-21	s CAP, CHIP ELECT 100MF(6.3X5.7)
C173	1-100-566-91	s CAP, CHIP CERAMIC 0.1MF B 1608
C174	1-126-392-21	s CAP, CHIP ELECT 100MF(6.3X5.7)
C175	1-100-566-91	s CAP, CHIP CERAMIC 0.1MF B 1608
C300	1-100-566-91	s CAP, CHIP CERAMIC 0.1MF B 1608
C301	1-131-661-21	s CAP, CHIP ELECT 100MF(6.3X5.7)
C302	1-126-412-21	s CAP, CHIP ELECT 220MF (4X5.7)
C303	1-100-566-91	s CAP, CHIP CERAMIC 0.1MF B 1608
C304	1-100-566-91	s CAP, CHIP CERAMIC 0.1MF B 1608
C305	1-100-566-91	s CAP, CHIP CERAMIC 0.1MF B 1608
C306	1-100-566-91	s CAP, CHIP CERAMIC 0.1MF B 1608
C307	1-162-970-91	s CAP, CERAMIC 10000PF B 1608
C308	1-162-970-91	s CAP, CERAMIC 10000PF B 1608
C309	1-162-970-91	s CAP, CERAMIC 10000PF B 1608
C310	1-162-970-91	s CAP, CERAMIC 10000PF B 1608
C311	1-126-392-21	s CAP, CHIP ELECT 100MF(6.3X5.7)
C312	1-100-566-91	s CAP, CHIP CERAMIC 0.1MF B 1608
C313	1-100-566-91	s CAP, CHIP CERAMIC 0.1MF B 1608
C314	1-100-566-91	s CAP, CHIP CERAMIC 0.1MF B 1608
C315	1-100-566-91	s CAP, CHIP CERAMIC 0.1MF B 1608
C316	1-100-566-91	s CAP, CHIP CERAMIC 0.1MF B 1608
C317	1-100-566-91	s CAP, CHIP CERAMIC 0.1MF B 1608
C318	1-162-970-91	s CAP, CERAMIC 10000PF B 1608
C319	1-162-970-91	s CAP, CERAMIC 10000PF B 1608
C320	1-162-970-91	s CAP, CERAMIC 10000PF B 1608
C321	1-162-970-91	s CAP, CERAMIC 10000PF B 1608
C322	1-162-970-91	s CAP, CERAMIC 10000PF B 1608
C323	1-162-970-91	s CAP, CERAMIC 10000PF B 1608
C324	1-162-970-91	s CAP, CERAMIC 10000PF B 1608
C325	1-100-566-91	s CAP, CHIP CERAMIC 0.1MF B 1608
C328	1-126-392-21	s CAP, CHIP ELECT 100MF(6.3X5.7)
C329	1-162-970-91	s CAP, CERAMIC 10000PF B 1608
C330	1-100-566-91	s CAP, CHIP CERAMIC 0.1MF B 1608
C331	1-100-566-91	s CAP, CHIP CERAMIC 0.1MF B 1608
C332	1-162-970-91	s CAP, CERAMIC 10000PF B 1608
C333	1-100-566-91	s CAP, CHIP CERAMIC 0.1MF B 1608
C334	1-100-566-91	s CAP, CHIP CERAMIC 0.1MF B 1608
C350	1-131-661-21	s CAP, CHIP ELECT 100MF(6.3X5.7)
C351	1-100-566-91	s CAP, CHIP CERAMIC 0.1MF B 1608

(HC BOARD)

Ref. No. or Q'ty	Part No.	SP Description
C352	1-100-566-91	s CAP, CHIP CERAMIC 0.1MF B 1608
C353	1-100-566-91	s CAP, CHIP CERAMIC 0.1MF B 1608
C354	1-125-817-91	s CAP, CERAMIC 10MF B (3216)
C355	1-126-394-21	s CAP, CHIP ELECT 10MF (4X5.7)
C356	1-100-566-91	s CAP, CHIP CERAMIC 0.1MF B 1608
C357	1-165-908-91	s CAP, CERAMIC 1000000PF B 1608
C358	1-126-394-21	s CAP, CHIP ELECT 10MF (4X5.7)
C359	1-126-391-21	s CAP, CHIP ELECT 47MF (5X5.7)
C360	1-128-934-91	s CAP,CHIP CERAMIC 0.33MF B 1608
C363	1-119-866-91	s CAP,CHIP CERAMIC 0.68MF B 2012
C364	1-165-176-91	s CAP,CERAMIC 47000PF B 1608
C365	1-100-566-91	s CAP, CHIP CERAMIC 0.1MF B 1608
C366	1-125-817-91	s CAP, CERAMIC 10MF B (3216)
C367	1-115-433-91	s CAP, CHIP CERAMIC390PF CH 1608
C368	1-162-970-91	s CAP, CERAMIC 10000PF B 1608
C370	1-128-590-21	s CAP, CHIP ELECT 100MF
C371	1-164-172-91	s CAP,CERAMIC 5600PF B 1608
C372	1-165-908-91	s CAP, CERAMIC 1000000PF B 1608
C373	1-126-394-21	s CAP, CHIP ELECT 10MF (4X5.7)
C375	1-100-566-91	s CAP, CHIP CERAMIC 0.1MF B 1608
C376	1-162-970-91	s CAP, CERAMIC 10000PF B 1608
C377	1-135-342-21	s CAP, ELECT 56MF (6.3X6)
C378	1-100-566-91	s CAP, CHIP CERAMIC 0.1MF B 1608
C379	1-165-908-91	s CAP, CERAMIC 1000000PF B 1608
C380	1-100-566-91	s CAP, CHIP CERAMIC 0.1MF B 1608
C381	1-135-344-21	s CAP, ELECT 270MF (10X8)
C382	1-165-908-91	s CAP, CERAMIC 1000000PF B 1608
C383	1-165-908-91	s CAP, CERAMIC 1000000PF B 1608
C384	1-128-590-21	s CAP, CHIP ELECT 100MF
C385	1-135-344-21	s CAP, ELECT 270MF (10X8)
C386	1-100-566-91	s CAP, CHIP CERAMIC 0.1MF B 1608
C388	1-135-344-21	s CAP, ELECT 270MF (10X8)
C389	1-135-344-21	s CAP, ELECT 270MF (10X8)
C390	1-100-566-91	s CAP, CHIP CERAMIC 0.1MF B 1608
C391	1-100-566-91	s CAP, CHIP CERAMIC 0.1MF B 1608
C392	1-165-671-21	s CAP, ELECT 470MF
C393	1-165-671-21	s CAP, ELECT 470MF
C394	1-100-566-91	s CAP, CHIP CERAMIC 0.1MF B 1608
C395	1-100-566-91	s CAP, CHIP CERAMIC 0.1MF B 1608
C396	1-165-671-21	s CAP, ELECT 470MF
C397	1-165-671-21	s CAP, ELECT 470MF
C398	1-100-566-91	s CAP, CHIP CERAMIC 0.1MF B 1608
C399	1-100-566-91	s CAP, CHIP CERAMIC 0.1MF B 1608
C400	1-100-566-91	s CAP, CHIP CERAMIC 0.1MF B 1608
C401	1-162-970-91	s CAP, CERAMIC 10000PF B 1608
C402	1-100-566-91	s CAP, CHIP CERAMIC 0.1MF B 1608
C403	1-100-566-91	s CAP, CHIP CERAMIC 0.1MF B 1608
C404	1-126-392-21	s CAP, CHIP ELECT 100MF(6.3X5.7)
C405	1-100-566-91	s CAP, CHIP CERAMIC 0.1MF B 1608
C407	1-100-566-91	s CAP, CHIP CERAMIC 0.1MF B 1608
C408	1-100-566-91	s CAP, CHIP CERAMIC 0.1MF B 1608
C409	1-100-566-91	s CAP, CHIP CERAMIC 0.1MF B 1608
C410	1-100-566-91	s CAP, CHIP CERAMIC 0.1MF B 1608
C411	1-100-566-91	s CAP, CHIP CERAMIC 0.1MF B 1608
C412	1-126-392-21	s CAP, CHIP ELECT 100MF(6.3X5.7)
C413	1-100-566-91	s CAP, CHIP CERAMIC 0.1MF B 1608
C414	1-100-566-91	s CAP, CHIP CERAMIC 0.1MF B 1608
C415	1-162-970-91	s CAP, CERAMIC 10000PF B 1608
C416	1-165-989-91	s CAP, CERAMIC 10MF (2012)

(HC BOARD)

Ref. No. or Q'ty	Part No.	SP	Description
C417	1-100-566-91	s	CAP, CHIP CERAMIC 0.1MF B 1608
C418	1-165-989-91	s	CAP, CERAMIC 10MF (2012)
C419	1-126-392-21	s	CAP, CHIP ELECT 100MF(6.3X5.7)
C659	1-162-923-91	s	CAP, CERAMIC 47PF CH 1608
CN001	1-764-080-21	o	PIN, CONNECTOR (PC BOARD) 8P
CN152	1-695-209-21	s	PIN, CONNECTOR (PC BOARD) 15P
CN153	1-764-087-21	s	PIN, CONNECTOR (PC BOARD) 14P
CN154	1-695-209-21	s	PIN, CONNECTOR (PC BOARD) 15P
CN400	1-817-653-11	s	MEMORY STICK CONNECTOR
CN401	1-764-081-21	s	PIN, CONNECTOR (PC BOARD) 9P
D151	8-719-036-98	s	DIODE RD6.2SB-T1
D152	8-719-036-80	s	DIODE RD3.9SB-T1
D153	8-719-036-80	s	DIODE RD3.9SB-T1
D154	8-719-036-98	s	DIODE RD6.2SB-T1
D155	8-719-036-98	s	DIODE RD6.2SB-T1
D301	8-719-038-07	s	DIODE CL-190PG-CD-T
D302	8-719-404-50	s	DIODE MA111-TX
D350	8-719-038-07	s	DIODE CL-190PG-CD-T
D351	8-719-038-07	s	DIODE CL-190PG-CD-T
D352	8-719-404-50	s	DIODE MA111-TX
D353	8-719-404-50	s	DIODE MA111-TX
D354	8-719-404-50	s	DIODE MA111-TX
D355	8-719-073-92	s	DIODE RB060L-40TE25
D356	8-719-073-92	s	DIODE RB060L-40TE25
D357	8-719-073-92	s	DIODE RB060L-40TE25
D358	8-719-069-56	s	DIODE UDZSTE-176.2B
D359	8-719-069-56	s	DIODE UDZSTE-176.2B
D400	8-719-036-80	s	DIODE RD3.9SB-T1
D401	8-719-024-78	s	DIODE HN1D03FU-TE85R
D402	6-500-632-01	s	DIODE CL-270D-C-TS
D403	8-719-024-78	s	DIODE HN1D03FU-TE85R
D404	8-719-037-22	s	DIODE RD12SB-T1
D405	8-719-037-22	s	DIODE RD12SB-T1
D406	8-719-037-22	s	DIODE RD12SB-T1
D407	8-719-037-22	s	DIODE RD12SB-T1
D408	8-719-037-22	s	DIODE RD12SB-T1
D409	8-719-037-22	s	DIODE RD12SB-T1
D410	8-719-037-22	s	DIODE RD12SB-T1
D411	8-719-037-22	s	DIODE RD12SB-T1
D412	8-719-036-80	s	DIODE RD3.9SB-T1
D413	8-719-036-80	s	DIODE RD3.9SB-T1
D414	8-719-404-50	s	DIODE MA111-TX
F350	1-576-269-21	s	FUSE (SMD) (3.15A/125V)
F351	1-576-269-21	s	FUSE (SMD) (3.15A/125V)
F352	1-576-269-21	s	FUSE (SMD) (3.15A/125V)
FB151	1-414-864-21	s	FERRITE, EMI (SMD) (1608)
FB152	1-414-864-21	s	FERRITE, EMI (SMD) (1608)
FB153	1-414-864-21	s	FERRITE, EMI (SMD) (1608)
FB154	1-414-864-21	s	FERRITE, EMI (SMD) (1608)
FB156	1-414-864-21	s	FERRITE, EMI (SMD) (1608)
FB158	1-414-864-21	s	FERRITE, EMI (SMD) (1608)
FB159	1-414-864-21	s	FERRITE, EMI (SMD) (1608)
FB160	1-400-150-21	s	FERRITE, EMI (SMD) (4516)
FB161	1-414-864-21	s	FERRITE, EMI (SMD) (1608)
FB162	1-414-864-21	s	FERRITE, EMI (SMD) (1608)
FB163	1-414-864-21	s	FERRITE, EMI (SMD) (1608)
FB303	1-414-864-21	s	FERRITE, EMI (SMD) (1608)

(HC BOARD)

Ref. No. or Q'ty	Part No.	SP	Description
FB304	1-414-864-21	s	FERRITE, EMI (SMD) (1608)
FB305	1-414-864-21	s	FERRITE, EMI (SMD) (1608)
FB306	1-414-864-21	s	FERRITE, EMI (SMD) (1608)
FB312	1-414-864-21	s	FERRITE, EMI (SMD) (1608)
FB313	1-414-864-21	s	FERRITE, EMI (SMD) (1608)
FB314	1-414-864-21	s	FERRITE, EMI (SMD) (1608)
FB350	1-469-379-21	s	FERRITE, EMI (SMD) (2012)
FB351	1-410-396-91	s	FERRITE BEAD INDUCTOR
FB352	1-410-396-91	s	FERRITE BEAD INDUCTOR
FB400	1-414-864-21	s	FERRITE, EMI (SMD) (1608)
FB401	1-414-864-21	s	FERRITE, EMI (SMD) (1608)
FB402	1-414-864-21	s	FERRITE, EMI (SMD) (1608)
FB403	1-414-864-21	s	FERRITE, EMI (SMD) (1608)
FB404	1-414-864-21	s	FERRITE, EMI (SMD) (1608)
IC151	8-759-679-54	s	IC SN74LVC14APWR
IC152	8-759-679-54	s	IC SN74LVC14APWR
IC153	8-759-573-97	s	IC SN74LVC541APWR
IC154	8-759-679-54	s	IC SN74LVC14APWR
IC156	8-759-592-49	s	IC TC7SZ125FU(TE85R)
IC157	8-759-099-44	s	IC TD62381FG(EL)
IC158	6-709-531-01	s	IC TD62783AFG(5.S.EL)
IC159	8-759-573-97	s	IC SN74LVC541APWR
IC160	8-759-573-97	s	IC SN74LVC541APWR
IC304	6-700-387-01	s	IC EPC2LC20N-TP
IC305	8-759-592-46	s	IC TC7SZ05FU(TE85R)
IC306	8-759-679-54	s	IC SN74LVC14APWR
IC307	6-708-748-01	s	IC BD4828FVE-TR
IC308	8-759-592-46	s	IC TC7SZ05FU(TE85R)
IC309	8-759-592-46	s	IC TC7SZ05FU(TE85R)
IC350	6-705-469-01	s	IC BA50BC0FP-E2
IC351	8-759-183-53	s	IC TL431CPK-E2
IC352	8-759-669-64	s	IC TL1451ACPWR-12
IC353	8-759-521-37	s	IC TL5001CDR
IC354	6-705-027-01	s	IC BD4840FVE-TR
IC400	6-703-649-01	s	IC CY7C1041CV33-15ZCT
IC401	6-700-424-01	s	IC MAX3243CDBR
IC402	8-759-584-32	s	IC MB86189PFV-G-BND-ER-E1
L350	1-424-700-21	s	COIL, CHOKE (SMD) 100UH
L351	1-400-323-21	s	CHOKE COIL (SMD) 47UH
L352	1-416-511-21	s	COIL, CHOKE 47.0UH
L353	1-416-948-21	s	COIL, CHOKE 10UH
L354	1-416-948-21	s	COIL, CHOKE 10UH
L355	1-416-344-21	s	COIL, CHOKE 10UH
L356	1-416-344-21	s	COIL, CHOKE 10UH
Q350	8-729-026-53	s	TRANSISTOR 2SA1576A-T106-QR
Q351	8-729-029-14	s	TRANSISTOR DTC144EUA-T106
Q352	8-729-028-91	s	TRANSISTOR DTA144EUA-T106
Q353	8-729-029-14	s	TRANSISTOR DTC144EUA-T106
Q354	8-729-028-91	s	TRANSISTOR DTA144EUA-T106
Q355	8-729-026-53	s	TRANSISTOR 2SA1576A-T106-QR
Q356	8-729-029-14	s	TRANSISTOR DTC144EUA-T106
Q357	8-729-029-14	s	TRANSISTOR DTC144EUA-T106
Q358	8-729-029-14	s	TRANSISTOR DTC144EUA-T106
Q359	8-729-054-99	s	TRANSISTOR SI4559EY-T1
Q360	8-729-028-91	s	TRANSISTOR DTA144EUA-T106
Q361	8-729-028-91	s	TRANSISTOR DTA144EUA-T106
Q362	8-729-029-14	s	TRANSISTOR DTC144EUA-T106
Q363	8-729-029-14	s	TRANSISTOR DTC144EUA-T106

(HC BOARD)

Ref. No. or Q'ty	Part No.	SP Description
Q364	8-729-029-14	s TRANSISTOR DTC144EUA-T106
Q365	8-729-029-14	s TRANSISTOR DTC144EUA-T106
Q366	8-729-920-75	s TRANSISTOR 2SC2412K-T-146-QR
Q367	8-729-920-75	s TRANSISTOR 2SC2412K-T-146-QR
Q368	8-729-920-75	s TRANSISTOR 2SC2412K-T-146-QR
Q369	8-729-920-75	s TRANSISTOR 2SC2412K-T-146-QR
Q370	8-729-920-75	s TRANSISTOR 2SC2412K-T-146-QR
Q371	8-729-026-50	s TRANSISTOR 2SA1037AK-T146-QR
Q372	8-729-920-75	s TRANSISTOR 2SC2412K-T-146-QR
Q373	8-729-026-50	s TRANSISTOR 2SA1037AK-T146-QR
Q374	8-729-045-53	s TRANSISTOR SI4431DY-T1
Q375	8-729-045-53	s TRANSISTOR SI4431DY-T1
Q400	8-729-026-53	s TRANSISTOR 2SA1576A-T106-QR
Q401	6-550-832-01	s TRANSISTOR SI2301BDS-T1
Q402	8-729-029-04	s TRANSISTOR DTC123JUA-T106
Q403	8-729-029-04	s TRANSISTOR DTC123JUA-T106
R151	1-216-837-91	s RES, CHIP 22K (1608)
R152	1-216-801-91	s RES, CHIP 22 (1608)
R153	1-216-801-91	s RES, CHIP 22 (1608)
R154	1-216-801-91	s RES, CHIP 22 (1608)
R155	1-216-801-91	s RES, CHIP 22 (1608)
R156	1-216-801-91	s RES, CHIP 22 (1608)
R158	1-216-801-91	s RES, CHIP 22 (1608)
R159	1-216-801-91	s RES, CHIP 22 (1608)
R160	1-216-833-91	s RES, CHIP 10K (1608)
R162	1-216-829-91	s RES, CHIP 4.7K (1608)
R164	1-216-829-91	s RES, CHIP 4.7K (1608)
R165	1-216-801-91	s RES, CHIP 22 (1608)
R166	1-216-801-91	s RES, CHIP 22 (1608)
R167	1-216-825-91	s RES, CHIP 2.2K (1608)
R168	1-216-825-91	s RES, CHIP 2.2K (1608)
R169	1-216-825-91	s RES, CHIP 2.2K (1608)
R170	1-216-825-91	s RES, CHIP 2.2K (1608)
R171	1-216-825-91	s RES, CHIP 2.2K (1608)
R172	1-216-825-91	s RES, CHIP 2.2K (1608)
R175	1-216-829-91	s RES, CHIP 4.7K (1608)
R176	1-216-829-91	s RES, CHIP 4.7K (1608)
R300	1-216-833-91	s RES, CHIP 10K (1608)
R301	1-216-833-91	s RES, CHIP 10K (1608)
R302	1-216-833-91	s RES, CHIP 10K (1608)
R303	1-216-829-91	s RES, CHIP 4.7K (1608)
R304	1-216-833-91	s RES, CHIP 10K (1608)
R305	1-216-833-91	s RES, CHIP 10K (1608)
R306	1-216-833-91	s RES, CHIP 10K (1608)
R308	1-216-833-91	s RES, CHIP 10K (1608)
R309	1-216-821-91	s RES, CHIP 1.0K (1608)
R311	1-216-801-91	s RES, CHIP 22 (1608)
R312	1-216-864-91	s CONDUCTOR, CHIP (1608)
R313	1-216-833-91	s RES, CHIP 10K (1608)
R314	1-216-864-91	s CONDUCTOR, CHIP (1608)
R315	1-216-833-91	s RES, CHIP 10K (1608)
R316	1-216-833-91	s RES, CHIP 10K (1608)
R317	1-216-864-91	s CONDUCTOR, CHIP (1608)
R318	1-216-864-91	s CONDUCTOR, CHIP (1608)
R321	1-216-833-91	s RES, CHIP 10K (1608)
R322	1-216-833-91	s RES, CHIP 10K (1608)
R330	1-216-821-91	s RES, CHIP 1.0K (1608)
R331	1-216-826-91	s RES, CHIP 2.7K (1608)

(HC BOARD)

Ref. No. or Q'ty	Part No.	SP Description
R332	1-216-809-91	s RES, CHIP 100 (1608)
R333	1-218-863-91	s RES, CHIP 4.7K (1608)
R334	1-218-863-91	s RES, CHIP 4.7K (1608)
R335	1-218-863-91	s RES, CHIP 4.7K (1608)
R336	1-218-883-91	s RES, CHIP 33K (1608)
R337	1-216-821-91	s RES, CHIP 1.0K (1608)
R338	1-218-871-91	s RES, CHIP 10K (1608)
R339	1-218-887-91	s RES, CHIP 47K (1608)
R340	1-216-821-91	s RES, CHIP 1.0K (1608)
R341	1-218-871-91	s RES, CHIP 10K (1608)
R342	1-219-706-21	s RES, CHIP (SQUARE TYPE) 0.10
R343	1-216-809-91	s RES, CHIP 100 (1608)
R344	1-218-911-91	s RES, CHIP 470K (1608)
R346	1-216-845-91	s RES, CHIP 100K (1608)
R347	1-218-887-91	s RES, CHIP 47K (1608)
R348	1-218-888-91	s RES, CHIP 51K (1608)
R349	1-218-856-91	s RES, CHIP 2.4K (1608)
R350	1-218-881-91	s RES, CHIP 27K (1608)
R351	1-216-845-91	s RES, CHIP 100K (1608)
R352	1-216-846-91	s RES, CHIP 120K (1608)
R353	1-216-846-91	s RES, CHIP 120K (1608)
R355	1-218-861-91	s RES, CHIP 3.9K (1608)
R356	1-218-887-91	s RES, CHIP 47K (1608)
R357	1-218-827-91	s RES, CHIP 150 (1608)
R358	1-218-903-91	s RES, CHIP 220K (1608)
R359	1-218-879-91	s RES, CHIP 22K (1608)
R360	1-216-817-91	s RES, CHIP 470 (1608)
R361	1-216-833-91	s RES, CHIP 10K (1608)
R363	1-216-817-91	s RES, CHIP 470 (1608)
R364	1-216-821-91	s RES, CHIP 1.0K (1608)
R365	1-218-873-91	s RES, CHIP 12K (1608)
R366	1-218-857-91	s RES, CHIP 2.7K (1608)
R367	1-218-830-91	s RES, CHIP 200 (1608)
R368	1-218-863-91	s RES, CHIP 4.7K (1608)
R369	1-218-863-91	s RES, CHIP 4.7K (1608)
R370	1-216-833-91	s RES, CHIP 10K (1608)
R371	1-218-871-91	s RES, CHIP 10K (1608)
R372	1-211-977-91	s RES, CHIP 22 (1608)
R373	1-216-821-91	s RES, CHIP 1.0K (1608)
R374	1-218-863-91	s RES, CHIP 4.7K (1608)
R376	1-218-863-91	s RES, CHIP 4.7K (1608)
R378	1-218-863-91	s RES, CHIP 4.7K (1608)
R380	1-218-859-91	s RES, CHIP 3.3K (1608)
R381	1-218-859-91	s RES, CHIP 3.3K (1608)
R384	1-218-863-91	s RES, CHIP 4.7K (1608)
R385	1-218-863-91	s RES, CHIP 4.7K (1608)
R386	1-216-801-91	s RES, CHIP 22 (1608)
R387	1-216-801-91	s RES, CHIP 22 (1608)
R400	1-216-829-91	s RES, CHIP 4.7K (1608)
R402	1-216-801-91	s RES, CHIP 22 (1608)
R403	1-216-801-91	s RES, CHIP 22 (1608)
R404	1-216-809-91	s RES, CHIP 100 (1608)
R405	1-216-833-91	s RES, CHIP 10K (1608)
R406	1-216-837-91	s RES, CHIP 22K (1608)
R407	1-216-821-91	s RES, CHIP 1.0K (1608)
R408	1-216-833-91	s RES, CHIP 10K (1608)
R409	1-216-801-91	s RES, CHIP 22 (1608)
R410	1-216-833-91	s RES, CHIP 10K (1608)
R412	1-216-833-91	s RES, CHIP 10K (1608)

(HC BOARD)

Ref. No. or Q'ty	Part No.	SP	Description
R413	1-216-833-91	s RES,	CHIP 10K (1608)
R414	1-216-809-91	s RES,	CHIP 100 (1608)
R415	1-216-801-91	s RES,	CHIP 22 (1608)
R416	1-216-807-91	s RES,	CHIP 68 (1608)
R417	1-216-807-91	s RES,	CHIP 68 (1608)
R418	1-216-801-91	s RES,	CHIP 22 (1608)
R419	1-216-801-91	s RES,	CHIP 22 (1608)
R420	1-216-833-91	s RES,	CHIP 10K (1608)
R421	1-216-809-91	s RES,	CHIP 100 (1608)
R422	1-216-801-91	s RES,	CHIP 22 (1608)
R423	1-216-801-91	s RES,	CHIP 22 (1608)
R424	1-216-809-91	s RES,	CHIP 100 (1608)
R425	1-216-845-91	s RES,	CHIP 100K (1608)
R426	1-216-809-91	s RES,	CHIP 100 (1608)
R429	1-216-807-91	s RES,	CHIP 68 (1608)
R551	1-216-801-91	s RES,	CHIP 22 (1608)
R552	1-216-801-91	s RES,	CHIP 22 (1608)
R553	1-216-801-91	s RES,	CHIP 22 (1608)
R554	1-216-801-91	s RES,	CHIP 22 (1608)
R555	1-216-809-91	s RES,	CHIP 100 (1608)
R556	1-216-809-91	s RES,	CHIP 100 (1608)
R557	1-216-809-91	s RES,	CHIP 100 (1608)
R558	1-216-809-91	s RES,	CHIP 100 (1608)
R559	1-216-809-91	s RES,	CHIP 100 (1608)
R560	1-216-809-91	s RES,	CHIP 100 (1608)
R561	1-216-809-91	s RES,	CHIP 100 (1608)
R562	1-216-809-91	s RES,	CHIP 100 (1608)
R563	1-216-809-91	s RES,	CHIP 100 (1608)
R564	1-216-809-91	s RES,	CHIP 100 (1608)
R565	1-216-809-91	s RES,	CHIP 100 (1608)
R566	1-216-801-91	s RES,	CHIP 22 (1608)
R567	1-216-801-91	s RES,	CHIP 22 (1608)
R568	1-216-801-91	s RES,	CHIP 22 (1608)
R569	1-216-801-91	s RES,	CHIP 22 (1608)
R570	1-216-801-91	s RES,	CHIP 22 (1608)
R571	1-216-801-91	s RES,	CHIP 22 (1608)
R572	1-216-801-91	s RES,	CHIP 22 (1608)
R573	1-216-801-91	s RES,	CHIP 22 (1608)
R574	1-216-801-91	s RES,	CHIP 22 (1608)
R575	1-216-801-91	s RES,	CHIP 22 (1608)
R576	1-216-801-91	s RES,	CHIP 22 (1608)
R577	1-216-801-91	s RES,	CHIP 22 (1608)
R578	1-216-801-91	s RES,	CHIP 22 (1608)
R579	1-216-801-91	s RES,	CHIP 22 (1608)
R580	1-216-801-91	s RES,	CHIP 22 (1608)
R581	1-216-801-91	s RES,	CHIP 22 (1608)
R582	1-216-801-91	s RES,	CHIP 22 (1608)
R583	1-216-801-91	s RES,	CHIP 22 (1608)
R584	1-216-801-91	s RES,	CHIP 22 (1608)
R585	1-216-801-91	s RES,	CHIP 22 (1608)
R586	1-216-801-91	s RES,	CHIP 22 (1608)
R587	1-216-801-91	s RES,	CHIP 22 (1608)
R588	1-216-801-91	s RES,	CHIP 22 (1608)
R589	1-216-801-91	s RES,	CHIP 22 (1608)
R590	1-216-809-91	s RES,	CHIP 100 (1608)
RB151	1-233-416-21	s RES,	CHIP NETWORK 22K (3216)
RB152	1-233-416-21	s RES,	CHIP NETWORK 22K (3216)
RB154	1-233-575-21	s RES,	CHIP NETWORK 22 (3216)
RB155	1-233-575-21	s RES,	CHIP NETWORK 22 (3216)

(HC BOARD)

Ref. No. or Q'ty	Part No.	SP	Description
RB156	1-233-575-21	s RES,	CHIP NETWORK 22 (3216)
RB157	1-233-575-21	s RES,	CHIP NETWORK 22 (3216)
RB158	1-233-575-21	s RES,	CHIP NETWORK 22 (3216)
RB159	1-233-575-21	s RES,	CHIP NETWORK 22 (3216)
RB160	1-233-575-21	s RES,	CHIP NETWORK 22 (3216)
RB161	1-233-575-21	s RES,	CHIP NETWORK 22 (3216)
RB162	1-233-575-21	s RES,	CHIP NETWORK 22 (3216)
RB163	1-233-576-21	s RES,	CHIP NETWORK 100 (3216)
RB166	1-234-370-21	s RES,	NETWORK 22 (1005X4)
RB167	1-234-370-21	s RES,	NETWORK 22 (1005X4)
RB168	1-234-370-21	s RES,	NETWORK 22 (1005X4)
RB169	1-234-370-21	s RES,	NETWORK 22 (1005X4)
RB301	1-234-370-21	s RES,	NETWORK 22 (1005X4)
RB302	1-234-370-21	s RES,	NETWORK 22 (1005X4)
RB303	1-234-370-21	s RES,	NETWORK 22 (1005X4)
RB304	1-234-370-21	s RES,	NETWORK 22 (1005X4)
RB305	1-234-369-21	s RES,	NETWORK 10 (1005X4)
RB400	1-234-524-21	s RES,	CHIP NETWORK 33 (3216)
RB401	1-234-524-21	s RES,	CHIP NETWORK 33 (3216)
RB402	1-233-575-21	s RES,	CHIP NETWORK 22 (3216)
RB403	1-234-524-21	s RES,	CHIP NETWORK 33 (3216)
RB404	1-233-575-21	s RES,	CHIP NETWORK 22 (3216)
RB405	1-234-524-21	s RES,	CHIP NETWORK 33 (3216)
RB406	1-242-963-21	s RES,	NETWORK 33 (1005X4)
RB407	1-242-963-21	s RES,	NETWORK 33 (1005X4)
RB408	1-242-963-21	s RES,	NETWORK 33 (1005X4)
RB409	1-242-963-21	s RES,	NETWORK 33 (1005X4)
RB410	1-234-369-21	s RES,	NETWORK 10 (1005X4)
RB411	1-234-369-21	s RES,	NETWORK 10 (1005X4)
RB412	1-234-369-21	s RES,	NETWORK 10 (1005X4)
RB413	1-234-369-21	s RES,	NETWORK 10 (1005X4)
S303	1-771-709-21	s SWITCH,	SLIDE
S304	1-771-721-21	s SWITCH,	TACTILE
TP101	1-535-877-22	s CHIP,	CHECKER
TP102	1-535-877-22	s CHIP,	CHECKER
TP103	1-535-877-22	s CHIP,	CHECKER
TP104	1-535-877-22	s CHIP,	CHECKER
TP301	1-535-877-22	s CHIP,	CHECKER
TP350	1-535-877-22	s CHIP,	CHECKER
TP351	1-535-877-22	s CHIP,	CHECKER
TP352	1-535-877-22	s CHIP,	CHECKER
TP353	1-535-877-22	s CHIP,	CHECKER
X301	1-795-983-11	s OSCILLATOR,	CRYSTAL

 HD BOARD

Ref. No. or Q'ty	Part No.	SP Description
1pc	A-1091-344-A	s MOUNTED CIRCUIT BOARD, HD
CN901	1-695-209-21	s PIN, CONNECTOR (PC BOARD) 15P
D901	6-501-156-01	s DIODE LB-303DA
D902	8-719-047-66	s DIODE CL-190D-CD-T
D903	8-719-047-66	s DIODE CL-190D-CD-T
D904	8-719-047-66	s DIODE CL-190D-CD-T
D911	8-719-036-98	s DIODE RD6.2SB-T1
D912	8-719-036-98	s DIODE RD6.2SB-T1
D913	8-719-036-98	s DIODE RD6.2SB-T1
D914	8-719-036-98	s DIODE RD6.2SB-T1
D915	8-719-036-98	s DIODE RD6.2SB-T1
D916	8-719-036-98	s DIODE RD6.2SB-T1
D917	8-719-036-98	s DIODE RD6.2SB-T1
D918	8-719-036-98	s DIODE RD6.2SB-T1
D919	8-719-036-98	s DIODE RD6.2SB-T1
D920	8-719-036-98	s DIODE RD6.2SB-T1
D921	8-719-036-98	s DIODE RD6.2SB-T1
D931	8-719-036-98	s DIODE RD6.2SB-T1
D932	8-719-036-98	s DIODE RD6.2SB-T1
D933	8-719-036-98	s DIODE RD6.2SB-T1
R920	1-216-813-91	s RES, CHIP 220 (1608)
R921	1-216-813-91	s RES, CHIP 220 (1608)
R922	1-216-813-91	s RES, CHIP 220 (1608)
R923	1-216-813-91	s RES, CHIP 220 (1608)
R924	1-216-813-91	s RES, CHIP 220 (1608)
R925	1-216-813-91	s RES, CHIP 220 (1608)
R926	1-216-813-91	s RES, CHIP 220 (1608)
R927	1-216-813-91	s RES, CHIP 220 (1608)
R928	1-216-818-91	s RES, CHIP 560 (1608)
R929	1-216-818-91	s RES, CHIP 560 (1608)
R930	1-216-818-91	s RES, CHIP 560 (1608)

 PA BOARD

Ref. No. or Q'ty	Part No.	SP Description
1pc	A-1109-177-A	s MOUNTED CIRCUIT BOARD, PA
2pcs	7-682-950-01	s SCREW +PSW 3X12
2pcs	4-036-948-91	s HEAT SINK (G) (A003,004)
1pc	4-047-285-01	s SHEET, INSULATING (Q108(1))
4pcs	4-382-854-11	s SCREW (M3X10), P, SW (+) (Q105(1),Q108(1),Q404(1),Q405(1))
1pc	7-322-065-48	o RUBBER, SILICONE RTV (KE-3490) (D108(1))
C101	1-107-492-91	s CAP, ELECT 47MF
C102	1-107-882-91	s CAP, ELECT 100MF
C103	1-104-653-91	s CAP, ELECT 220MF
C104	1-165-441-81	s CAP, ELECT 33MF
C105	1-108-425-91	s CAP, PE TEREPHTHALATE 0.022MF
C106	1-162-970-91	s CAP, CERAMIC 10000PF B 1608
C107	1-162-134-91	s CAP, CERAMIC 470PF B
C108	1-136-069-11	s CAP, P.P FILM 4400PF
C109	1-104-990-91	s CAP, PETP FILM 0.0033MF
C110	1-117-671-11	s CAP, PP FILM (S) 1.0MF
C111	1-165-751-31	s CAP, ELECT 330MF 105
C113	1-115-350-91	s CAP, CERAMIC 4700PF E
C116	1-108-425-91	s CAP, PE TEREPHTHALATE 0.022MF
C117	1-164-004-91	s CAP, CERAMIC 100000PF B (2012)
C118	1-165-875-91	s CAP, CHIP CERAMIC 10MF B 3216
C119	1-164-315-91	s CAP, CERAMIC 470PF CH (1608)
C120	1-163-021-91	s CAP, CERAMIC 10000PF B (2012)
C121	1-163-021-91	s CAP, CERAMIC 10000PF B (2012)
C122	1-163-021-91	s CAP, CERAMIC 10000PF B (2012)
C151	1-128-526-91	s CAP, ELECT 100MF
C152	1-107-882-91	s CAP, ELECT 100MF
C153	1-107-882-91	s CAP, ELECT 100MF
C161	1-128-526-91	s CAP, ELECT 100MF
C201	1-100-566-91	s CAP, CHIP CERAMIC 0.1MF B 1608
C202	1-104-653-91	s CAP, ELECT 220MF
C203	1-162-970-91	s CAP, CERAMIC 10000PF B 1608
C402	1-100-566-91	s CAP, CHIP CERAMIC 0.1MF B 1608
C403	1-100-566-91	s CAP, CHIP CERAMIC 0.1MF B 1608
C404	1-100-566-91	s CAP, CHIP CERAMIC 0.1MF B 1608
C405	1-131-608-91	s CAP, CHIP CERAMIC 2.2MF B 3216
C501	1-107-882-91	s CAP, ELECT 100MF
C502	1-100-566-91	s CAP, CHIP CERAMIC 0.1MF B 1608
C503	1-107-906-91	s CAP, ELECT 10MF
C504	1-164-739-91	s CAP, CERAMIC 560PF CH (1608)
C505	1-107-882-91	s CAP, ELECT 100MF
C506	1-100-566-91	s CAP, CHIP CERAMIC 0.1MF B 1608
C507	1-162-964-91	s CAP,CHIP CERAMIC 1000PF B 1608
C508	1-164-315-91	s CAP, CERAMIC 470PF CH (1608)
C509	1-107-905-91	s CAP, ELECT 4.7MF
C510	1-162-923-91	s CAP, CERAMIC 47PF CH 1608
C511	1-162-966-91	s CAP, CERAMIC 2200PF B 1608
C512	1-162-964-91	s CAP,CHIP CERAMIC 1000PF B 1608
C514	1-100-566-91	s CAP, CHIP CERAMIC 0.1MF B 1608
C515	1-137-369-91	s CAP, PETP FILM 0.0068MF
C516	1-137-395-91	s CAP, PETP FILM 0.022MF
C551	1-100-566-91	s CAP, CHIP CERAMIC 0.1MF B 1608
C552	1-100-566-91	s CAP, CHIP CERAMIC 0.1MF B 1608
C553	1-100-566-91	s CAP, CHIP CERAMIC 0.1MF B 1608
C601	1-107-882-91	s CAP, ELECT 100MF
C602	1-100-566-91	s CAP, CHIP CERAMIC 0.1MF B 1608

(PA BOARD)

Ref. No. or Q'ty	Part No.	SP	Description
C651	1-107-909-91	s	CAP, ELECT 47MF
C652	1-107-905-91	s	CAP, ELECT 4.7MF
C653	1-107-696-91	s	CAP, ELECT 47MF
C654	1-162-970-91	s	CAP, CERAMIC 10000PF B 1608
C655	1-127-573-91	s	CAP, CHIP CERAMIC 1MF B (2012)
C603	1-107-906-91	s	CAP, ELECT 10MF
C604	1-162-970-91	s	CAP, CERAMIC 10000PF B 1608
C605	1-127-573-91	s	CAP, CHIP CERAMIC 1MF B (2012)
C606	1-127-573-91	s	CAP, CHIP CERAMIC 1MF B (2012)
C607	1-127-573-91	s	CAP, CHIP CERAMIC 1MF B (2012)
C608	1-100-566-91	s	CAP, CHIP CERAMIC 0.1MF B 1608
C609	1-135-960-91	s	CAP, CHIP CERAMIC 10MF B(3225)
CN101	1-566-549-11	s	CONNECTOR 34P
CN102	1-564-513-11	o	PLUG, CONNECTOR 10P
CN103	1-766-243-11	o	PIN, CONNECTOR (PC BOARD) 5P
CN104	1-766-241-11	o	PIN, CONNECTOR (PC BOARD) 3P
CN105	1-766-240-11	o	PIN, CONNECTOR (PC BOARD) 2P
D101	8-719-404-50	s	DIODE MA111-TX
D102	8-719-112-81	s	DIODE RD12ES-T1B2
D103	8-719-991-19	s	DIODE ERC91-02TP11
D104	8-719-036-87	s	DIODE RD4.7SB-T1
D105	8-719-991-33	s	DIODE 1SS133T-77
D106	8-719-023-46	s	DIODE ERD38-06TP11
D108	8-719-979-23	s	DIODE RGP02-17PKG23
D201	8-719-404-50	s	DIODE MA111-TX
D202	8-719-404-50	s	DIODE MA111-TX
D203	8-719-404-50	s	DIODE MA111-TX
D204	8-719-036-94	s	DIODE RD5.6SB-T1
D301	8-719-404-50	s	DIODE MA111-TX
D401	8-719-404-50	s	DIODE MA111-TX
D402	8-719-404-50	s	DIODE MA111-TX
D451	8-719-404-50	s	DIODE MA111-TX
D452	8-719-404-50	s	DIODE MA111-TX
D501	8-719-404-50	s	DIODE MA111-TX
D502	8-719-404-50	s	DIODE MA111-TX
D504	8-719-036-88	s	DIODE RD4.7SB1-T1
D505	8-719-036-94	s	DIODE RD5.6SB-T1
D506	8-719-404-50	s	DIODE MA111-TX
D507	8-719-404-50	s	DIODE MA111-TX
D508	8-719-404-50	s	DIODE MA111-TX
D509	8-719-037-22	s	DIODE RD12SB-T1
D510	8-719-404-50	s	DIODE MA111-TX
D601	8-759-300-59	s	DIODE HZT33-02TA
D602	8-719-404-50	s	DIODE MA111-TX
D603	8-719-404-50	s	DIODE MA111-TX
D604	8-719-404-50	s	DIODE MA111-TX
D605	8-719-036-70	s	DIODE RD2.7SB2-T1
D608	8-719-404-50	s	DIODE MA111-TX
D609	8-719-036-88	s	DIODE RD4.7SB1-T1
D651	8-759-300-59	s	DIODE HZT33-02TA
D652	8-719-404-50	s	DIODE MA111-TX
D653	8-719-404-50	s	DIODE MA111-TX
D654	8-719-036-74	s	DIODE RD3.3SB-T1
D655	8-719-404-50	s	DIODE MA111-TX
D656	8-719-404-50	s	DIODE MA111-TX
D657	8-719-036-65	s	DIODE RD2.0SB-T1
D659	8-719-036-88	s	DIODE RD4.7SB1-T1
D660	8-719-404-50	s	DIODE MA111-TX
FB101	1-410-397-51	s	FERRITE BEAD INDUCTOR

(PA BOARD)

Ref. No. or Q'ty	Part No.	SP	Description
IC101	8-759-523-04	s	IC TC74HC4538AFT(EL)
IC151	8-759-701-79	s	IC NJM7812FA
IC152	8-759-929-65	s	IC LM7912CT
IC201	8-759-330-83	s	IC NJM2904M(TE2)
IC501	8-759-663-28	s	IC BA9758AFS-E2
IC502	8-759-157-42	s	IC TL082CPS-E20
IC601	8-759-276-28	s	IC LM393PS-E20
L101	1-412-529-41	s	MICRO INDUCTOR 22UH
L102	1-406-659-21	s	COIL, CHOKE 10UH
Q101	8-729-905-38	s	TRANSISTOR 2SC4081T106R
Q102	8-729-026-53	s	TRANSISTOR 2SA1576A-T106-QR
Q103	8-729-029-14	s	TRANSISTOR DTC144EUA-T106
Q104	8-729-208-13	s	TRANSISTOR 2SA10910-TPE2
Q105	8-729-054-30	s	TRANSISTOR 2SJ585LS-CB11
Q106	8-729-019-85	s	TRANSISTOR 2SC3392-5-TB-E
Q107	8-729-824-24	s	TRANSISTOR 2SA1338-5-TB-E
Q108	8-729-020-63	s	TRANSISTOR 2SK1120LBSOBY
Q109	8-729-029-14	s	TRANSISTOR DTC144EUA-T106
Q201	8-729-020-07	s	TRANSISTOR 2SC4686A(LBSOBY)
Q202	8-729-020-07	s	TRANSISTOR 2SC4686A(LBSOBY)
Q203	8-729-029-14	s	TRANSISTOR DTC144EUA-T106
Q204	8-729-026-53	s	TRANSISTOR 2SA1576A-T106-QR
Q301	8-729-020-07	s	TRANSISTOR 2SC4686A(LBSOBY)
Q401	8-729-026-53	s	TRANSISTOR 2SA1576A-T106-QR
Q402	8-729-026-53	s	TRANSISTOR 2SA1576A-T106-QR
Q403	8-729-905-38	s	TRANSISTOR 2SC4081T106R
Q404	8-729-820-53	s	TRANSISTOR 2SD1683-T
Q405	8-729-117-12	s	TRANSISTOR 2SB1151-K
Q451	8-729-020-07	s	TRANSISTOR 2SC4686A(LBSOBY)
Q452	8-729-020-07	s	TRANSISTOR 2SC4686A(LBSOBY)
Q501	8-729-026-53	s	TRANSISTOR 2SA1576A-T106-QR
Q601	8-729-028-73	s	TRANSISTOR DTA114EUA-T106
Q602	8-729-029-14	s	TRANSISTOR DTC144EUA-T106
Q603	8-729-029-14	s	TRANSISTOR DTC144EUA-T106
Q651	8-729-028-73	s	TRANSISTOR DTA114EUA-T106
Q652	8-729-029-14	s	TRANSISTOR DTC144EUA-T106
R101	1-216-833-91	s	RES, CHIP 10K (1608)
R102	1-218-831-91	s	RES, CHIP 220 (1608)
R103	1-215-479-91	s	RES, METAL FILM(SMALL TYPE) 270K
R104	1-216-347-71	s	RES, METAL OXIDE FILM 0.68
R105	1-215-477-91	s	RES, METAL FILM(SMALL TYPE) 220K
R106	1-216-824-91	s	RES, CHIP 1.8K (1608)
R107	1-216-833-91	s	RES, CHIP 10K (1608)
R108	1-218-831-91	s	RES, CHIP 220 (1608)
R109	1-215-479-91	s	RES, METAL FILM(SMALL TYPE) 270K
R110	1-216-837-91	s	RES, CHIP 22K (1608)
R111	1-249-397-91	s	RES, CARBON (SMALL) 22
R112	1-216-797-91	s	RES, CHIP 10 (1608)
R113	1-216-821-91	s	RES, CHIP 1.0K (1608)
R114	1-249-397-91	s	RES, CARBON (SMALL) 22
R115	1-215-913-71	s	RES, METAL OXIDE FILM 220
R116	1-215-913-71	s	RES, METAL OXIDE FILM 220
R117	1-249-381-91	s	RES, CARBON (SMALL) 1
R119	1-211-828-71	s	RES, FUSE 470
R120	1-215-445-91	s	RES, METAL FILM(SMALL TYPE) 10K
R121	1-218-903-91	s	RES, CHIP 220K (1608)
R122	1-216-843-91	s	RES, CHIP 68K (1608)
R123	1-216-843-91	s	RES, CHIP 68K (1608)
R124	1-216-843-91	s	RES, CHIP 68K (1608)

(PA BOARD)

Ref. No. or Q'ty	Part No.	SP Description
R125	1-216-843-91	s RES, CHIP 68K (1608)
R126	1-216-839-91	s RES, CHIP 33K (1608)
R151	1-249-392-91	s RES, CARBON (SMALL) 8.2
R152	1-249-392-91	s RES, CARBON (SMALL) 8.2
R201	1-218-905-91	s RES, CHIP 270K (1608)
R202	1-218-889-91	s RES, CHIP 56K (1608)
R203	1-216-833-91	s RES, CHIP 10K (1608)
R204	1-216-845-91	s RES, CHIP 100K (1608)
R205	1-218-896-91	s RES, CHIP 110K (1608)
R206	1-216-829-91	s RES, CHIP 4.7K (1608)
R207	1-218-901-91	s RES, CHIP 180K (1608)
R208	1-245-946-11	s RES, METAL FILM 10M
R209	1-218-888-91	s RES, CHIP 51K (1608)
R210	1-245-946-11	s RES, METAL FILM 10M
R211	1-219-759-91	s RESISTOR (SURGE RESISTANT) 1M
R212	1-218-859-91	s RES, CHIP 3.3K (1608)
R213	1-218-859-91	s RES, CHIP 3.3K (1608)
R214	1-216-822-91	s RES, CHIP 1.2K (1608)
R301	1-216-821-91	s RES, CHIP 1.0K (1608)
R302	1-216-837-91	s RES, CHIP 22K (1608)
R303	1-216-833-91	s RES, CHIP 10K (1608)
R304	1-216-833-91	s RES, CHIP 10K (1608)
R305	1-216-848-91	s RES, CHIP 180K (1608)
R306	1-219-759-91	s RESISTOR (SURGE RESISTANT) 1M
R402	1-216-833-91	s RES, CHIP 10K (1608)
R403	1-216-809-91	s RES, CHIP 100 (1608)
R404	1-216-831-91	s RES, CHIP 6.8K (1608)
R405	1-216-822-91	s RES, CHIP 1.2K (1608)
R406	1-216-814-91	s RES, CHIP 270 (1608)
R407	1-216-829-91	s RES, CHIP 4.7K (1608)
R408	1-249-393-91	s RES, CARBON (SMALL) 10
R409	1-249-393-91	s RES, CARBON (SMALL) 10
R410	1-215-862-71	s RES, METAL OXIDE FILM 68
R411	1-215-862-71	s RES, METAL OXIDE FILM 68
R412	1-245-945-11	s RES, METAL FILM 2M
R413	1-216-827-91	s RES, CHIP 3.3K (1608)
R451	1-216-846-91	s RES, CHIP 120K (1608)
R452	1-245-945-11	s RES, METAL FILM 2M
R453	1-245-946-11	s RES, METAL FILM 10M
R454	1-219-749-91	s RESISTOR (SURGE RESISTANT) 10K
R501	1-216-837-91	s RES, CHIP 22K (1608)
R502	1-218-895-91	s RES, CHIP 100K (1608)
R503	1-216-830-91	s RES, CHIP 5.6K (1608)
R504	1-216-821-91	s RES, CHIP 1.0K (1608)
R505	1-216-829-91	s RES, CHIP 4.7K (1608)
R506	1-216-829-91	s RES, CHIP 4.7K (1608)
R507	1-216-829-91	s RES, CHIP 4.7K (1608)
R508	1-216-841-81	s RES, CHIP 47K (1608)
R509	1-216-841-81	s RES, CHIP 47K (1608)
R510	1-216-841-81	s RES, CHIP 47K (1608)
R511	1-216-809-91	s RES, CHIP 100 (1608)
R512	1-216-833-91	s RES, CHIP 10K (1608)
R513	1-218-883-91	s RES, CHIP 33K (1608)
R514	1-218-875-91	s RES, CHIP 15K (1608)
R515	1-218-863-91	s RES, CHIP 4.7K (1608)
R516	1-216-833-91	s RES, CHIP 10K (1608)
R517	1-216-845-91	s RES, CHIP 100K (1608)
R518	1-219-753-91	s RESISTOR (SURGE RESISTANT) 220K
R519	1-219-748-91	s RESISTOR (SURGE RESISTANT) 4.7K
R520	1-216-845-91	s RES, CHIP 100K (1608)

(PA BOARD)

Ref. No. or Q'ty	Part No.	SP Description
R521	1-216-809-91	s RES, CHIP 100 (1608)
R551	1-216-809-91	s RES, CHIP 100 (1608)
R552	1-216-845-91	s RES, CHIP 100K (1608)
R553	1-216-809-91	s RES, CHIP 100 (1608)
R601	1-215-902-71	s RES, METAL OXIDE FILM 47K
R602	1-218-897-91	s RES, CHIP 120K (1608)
R603	1-218-912-91	s RES, CHIP 510K (1608)
R604	△ 1-218-912-91	s RES, CHIP 510K (1608)
R605	1-216-864-91	s CONDUCTOR, CHIP (1608)
R606	△ 1-218-894-91	s RES, CHIP 91K (1608)
R607	△ 1-218-870-91	s RES, CHIP 9.1K (1608)
R608	1-216-837-91	s RES, CHIP 22K (1608)
R651	1-215-902-71	s RES, METAL OXIDE FILM 47K
R652	1-218-888-91	s RES, CHIP 51K (1608)
R653	1-218-887-91	s RES, CHIP 47K (1608)
R654	1-218-879-91	s RES, CHIP 22K (1608)
R655	1-218-890-91	s RES, CHIP 62K (1608)
R656	1-218-877-91	s RES, CHIP 18K (1608)
R657	1-216-837-91	s RES, CHIP 22K (1608)
R658	1-216-823-91	s RES, CHIP 1.5K (1608)
RV501	☒ 1-228-991-11	s RES, ADJ, METAL GLAZE 2.2K
RV601	☒ 1-228-994-11	s RES, ADJ, METAL GLAZE 10K
T101	△ 1-429-284-11	s TRANSFORMER, FERRITE (LOT)
T401	△ 1-424-555-12	s TRANSFORMER, FERRITE (DFT)
TP501	1-535-877-22	s CHIP, CHECKER
TP502	1-535-877-22	s CHIP, CHECKER
TP503	1-535-877-22	s CHIP, CHECKER
TP504	1-535-877-22	s CHIP, CHECKER
TP601	1-535-877-22	s CHIP, CHECKER
TP602	1-535-877-22	s CHIP, CHECKER
TP603	1-535-877-22	s CHIP, CHECKER

PC BOARD		

Ref. No. or Q'ty	Part No.	SP Description
1pc	A-1168-480-A	s MOUNTED CIRCUIT BOARD, PC
1pc	4-061-099-01	o RING, FBT (A001)
1pc	7-322-065-48	o RUBBER, SILICONE RTV (KE-3490) (C701-C702(1))
C701	1-104-993-91	s CAP, PETP FILM 0.01MF
C702	1-137-399-91	s CAP, PETP FILM 0.1MF
CN701	1-766-243-11	o PIN, CONNECTOR (PC BOARD) 5P
CN702	1-564-513-11	o PLUG, CONNECTOR 10P
CN703	1-508-766-13	o PIN, CONNECTOR (5MM PITCH) 4P
D702	8-719-936-85	s DIODE RGP10G-6038E3/23
NEL701	1-517-778-21	s LAMP, NEON
NEL702	1-517-778-21	s LAMP, NEON
R701	1-215-439-91	s RES, METAL FILM (SMALL TYPE) 5.6K
R702	1-215-438-91	s RES, METAL FILM (SMALL TYPE) 5.1K
R703	1-215-426-91	s RES, METAL FILM (SMALL TYPE) 1.6K
R704	1-215-439-91	s RES, METAL FILM (SMALL TYPE) 5.6K
R705	1-215-439-91	s RES, METAL FILM (SMALL TYPE) 5.6K
R706	1-215-427-91	s RES, METAL FILM (SMALL TYPE) 1.8K
R707	1-249-404-91	s RES, CARBON (SMALL) 82
R708	1-215-493-91	s RES, METAL FILM (SMALL TYPE) 1.0M
T701	△ 1-453-476-11	s FBT ASSY R/P (WITH ANODE CAP)

TA BOARD

Ref. No. or Q'ty	Part No.	SP Description
1pc	A-1091-232-A	s MOUNTED CIRCUIT BOARD, TA
CN101	1-817-755-11	o CONNECTOR, BOARD TO BOARD 100P
CN102	1-817-755-11	o CONNECTOR, BOARD TO BOARD 100P
CN103	1-817-755-11	o CONNECTOR, BOARD TO BOARD 100P
CN104	1-817-755-11	o CONNECTOR, BOARD TO BOARD 100P
CN105	1-817-755-11	o CONNECTOR, BOARD TO BOARD 100P
CN108	1-564-506-51	o PLUG, CONNECTOR 3P
CN109	1-564-505-11	s PLUG, CONNECTOR 2P
CN110	1-564-704-11	s PIN, CONNECTOR (SMALL TYPE) 2P
CN112	1-566-549-11	s CONNECTOR 34P
CN114	1-564-508-81	o PLUG, CONNECTOR 5P

TB BOARD

Ref. No. or Q'ty	Part No.	SP Description
1pc	A-1168-482-A	s MOUNTED CIRCUIT BOARD, TB
CN201	1-817-755-11	o CONNECTOR, BOARD TO BOARD 100P
CN202	1-817-755-11	o CONNECTOR, BOARD TO BOARD 100P
CN205	1-817-755-11	o CONNECTOR, BOARD TO BOARD 100P
CN206	1-817-755-11	o CONNECTOR, BOARD TO BOARD 100P
CN207	1-817-755-11	o CONNECTOR, BOARD TO BOARD 100P
CN208	1-817-755-11	o CONNECTOR, BOARD TO BOARD 100P
CN209	1-817-755-11	o CONNECTOR, BOARD TO BOARD 100P
CN210	1-817-755-11	o CONNECTOR, BOARD TO BOARD 100P
CN211	1-817-755-11	o CONNECTOR, BOARD TO BOARD 100P
CN212	1-817-755-11	o CONNECTOR, BOARD TO BOARD 100P
CN213	1-817-755-11	o CONNECTOR, BOARD TO BOARD 100P

YA BOARD

Ref. No. or Q'ty	Part No.	SP Description
1pc	A-1177-957-A	s MOUNTED CIRCUIT BOARD, YA
1pc	4-050-876-01	o PLATE, LIGHT INTERCEPTION (A1201)
CN1201	1-564-517-11	o PLUG, CONNECTOR 2P
D1201	8-719-061-96	s DIODE SLR-325DCT31
D1202	8-719-061-96	s DIODE SLR-325DCT31
D1203	8-719-061-96	s DIODE SLR-325DCT31
D1204	8-719-061-96	s DIODE SLR-325DCT31
D1205	8-719-061-96	s DIODE SLR-325DCT31
R1201	1-247-835-91	s RES, CARBON (SMALL) 1.5K
R1202	1-247-835-91	s RES, CARBON (SMALL) 1.5K
R1203	1-247-835-91	s RES, CARBON (SMALL) 1.5K
R1204	1-247-835-91	s RES, CARBON (SMALL) 1.5K
R1205	1-247-835-91	s RES, CARBON (SMALL) 1.5K

YB BOARD

Ref. No. or Q'ty	Part No.	SP Description
1pc	A-1091-225-A	s MOUNTED CIRCUIT BOARD, YB
CN1301	1-566-759-11	o PIN, CONNECTOR (PC BOARD) 4P
D1301	8-719-060-27	s DIODE SLR-325MCT31
D1302	8-719-053-43	s DIODE SLR-325VCT31
D1303	8-719-061-96	s DIODE SLR-325DCT31

YC BOARD

Ref. No. or Q'ty	Part No.	SP Description
1pc	A-1091-226-A	s MOUNTED CIRCUIT BOARD, YC
CN1401	1-564-724-11	o PIN, CONNECTOR (SMALL TYPE) 8P
CN1402	1-774-533-11	s SOCKET, SMALL TYPE DIN (8P)

SUPPLIED ACCESSORIES

Ref. No. or Q'ty	Part No.	SP Description
1pc	2-593-879-02	s OPERATION MANUAL (JAPANESE, ENGLISH)
1pc	2-990-242-01	s HOLDER (B), PLUG
1pc	4-051-743-01	s PLATE, TALLY
1pc	1-534-827-14	s CORD, POWER 125V, 10A (U/C)
1pc	1-783-481-42	s CORD, POWER 250V, 10A (CHINA)

Section 7 Block Diagrams

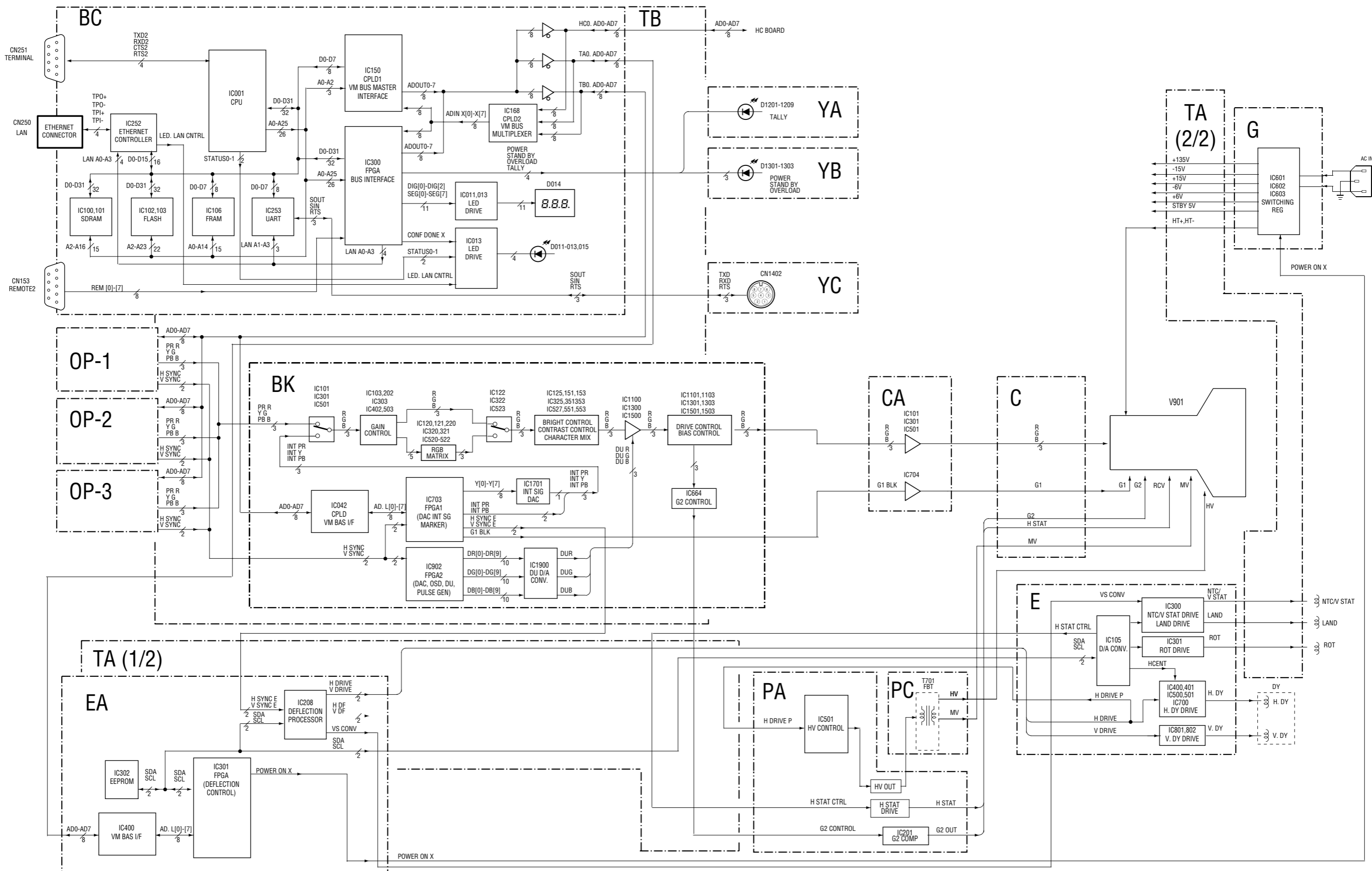

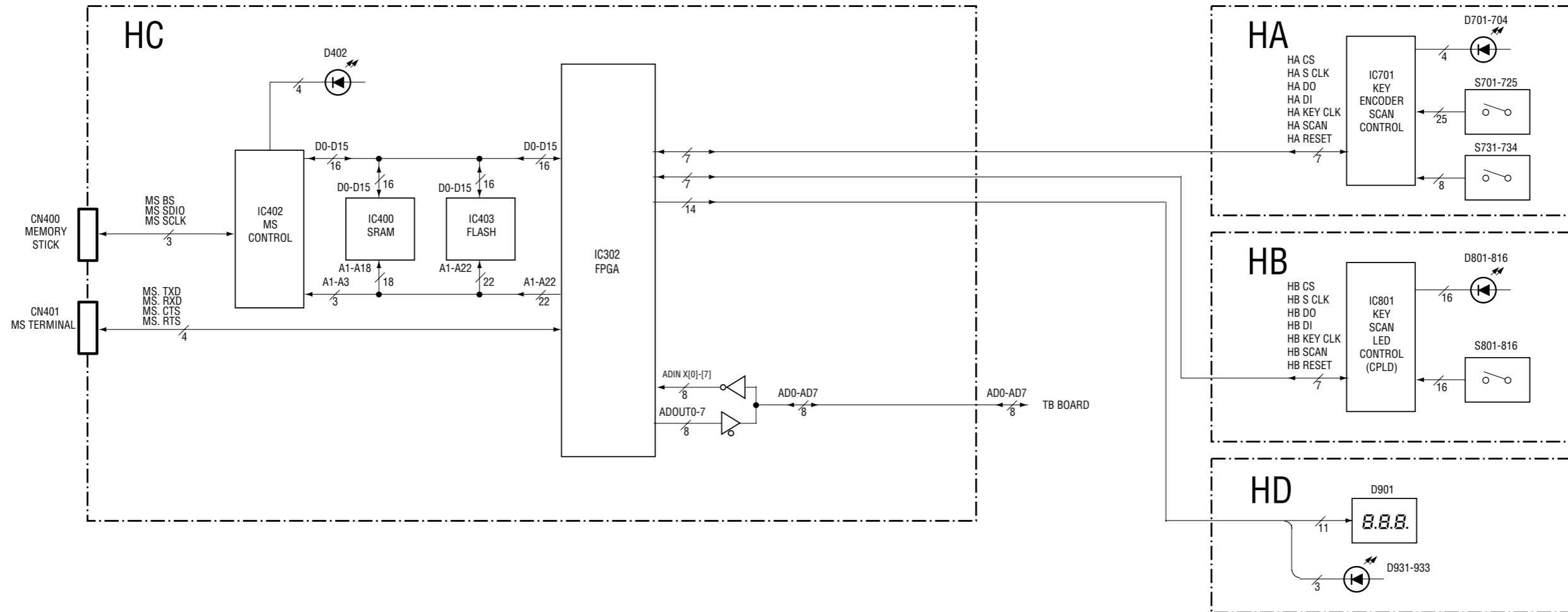

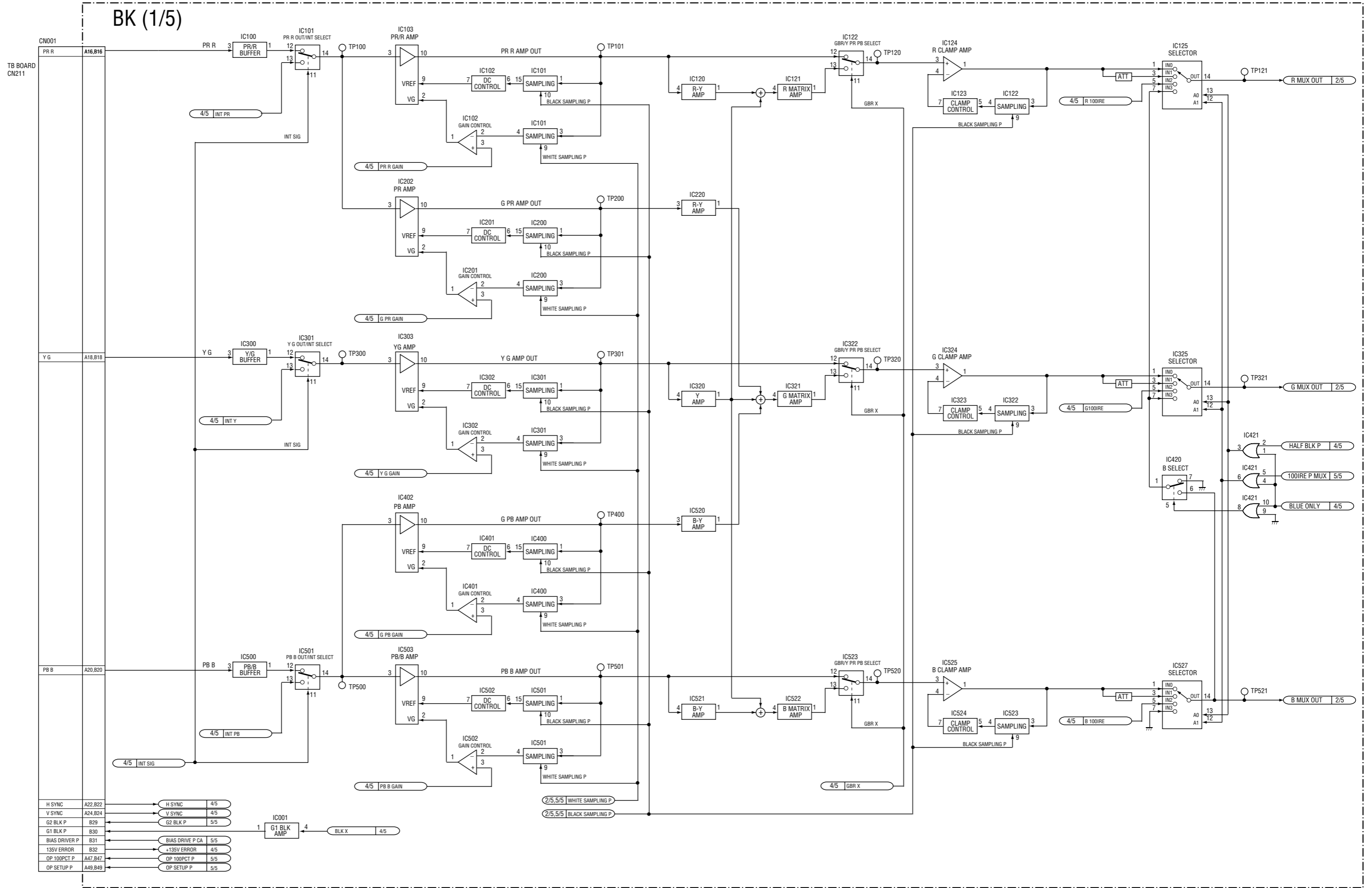

H SYNC	A22, B22	H SYNC	4/5
V SYNC	A24, B24	V SYNC	4/5
G2 BLK P	B29	G2 BLK P	5/5
G1 BLK P	B30		
BIAS DRIVER P	B31	BIAS DRIVE P CA	5/5
135V ERROR	B32	+135V ERROR	4/5
OP 100PCT P	A47, B47	OP 100PCT P	5/5
OP SETUP P	A49, B49	OP SETUP P	5/5

BK (2/5)

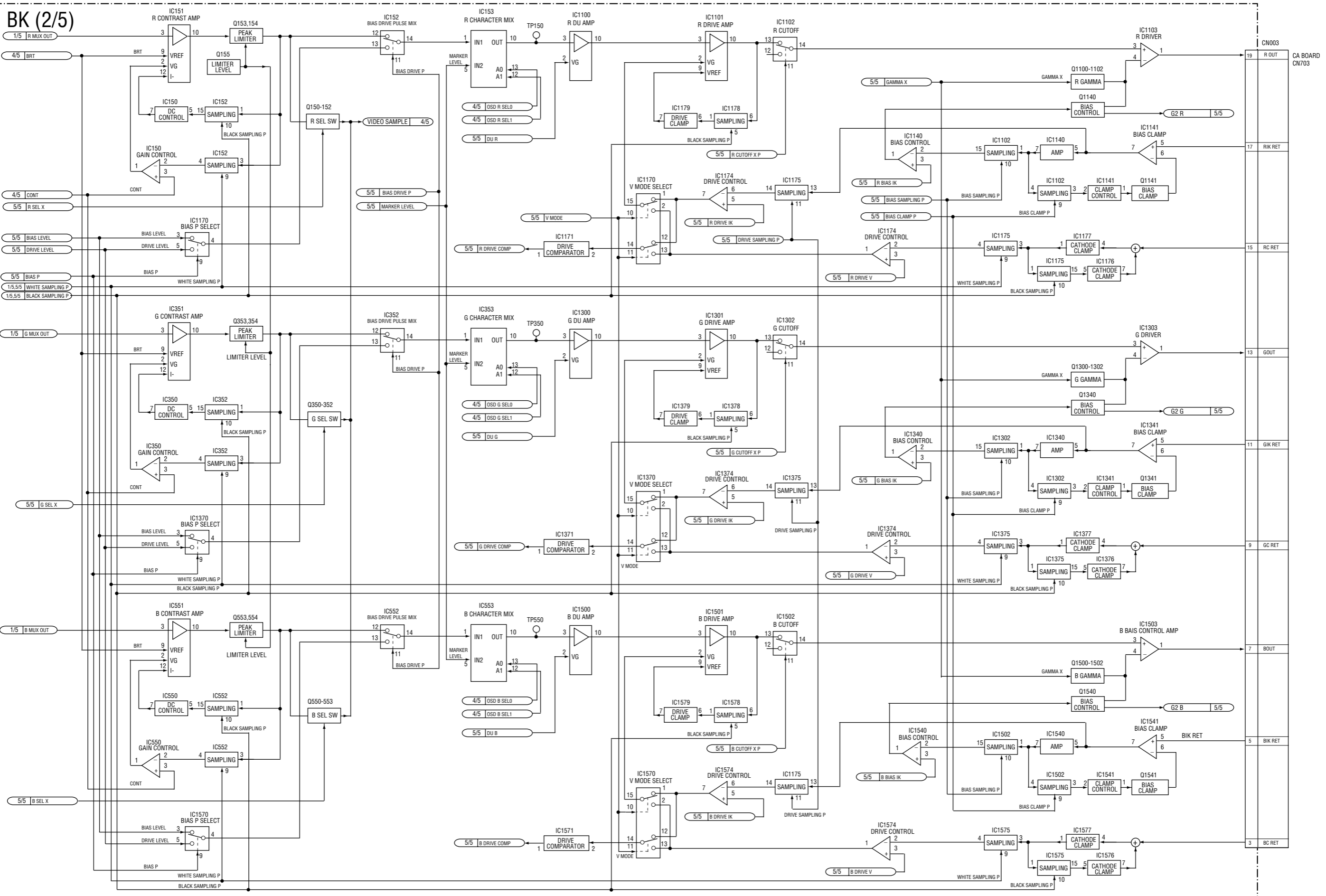

BK (3/5)

TB BOARD
CN212

CN002			
ABL	A12	ABL	4/5
G2 CONTROL	B12	G2 CONTROL	5/5
AFC P	B13	AFC P	5/5
V DRIVE P	B14	V DRIVE P	5/5
DF MASK P	B15	DF MASK P	5/5
ASD REF P	B16	ASD REF P	5/5
CONV PLL H	B19	CONV PLL H	5/5
CONV PLL V	B20	CONV PLL V	5/5
H SYNC E	B25	H SYNC E	4/5
V SYNC E	B26	V SYNC E	4/5

AD0-AD7	A37,B37 A38,B38 A39,B39 A40,B40
---------	--

R/W X	A41
A X/D	A42
IRQ X BK	A46
CLK RW BK	A44

RESET X	B41
---------	-----

STBY 3.3V	A47
-----------	-----

JATG TDI	B47
JATG TCK	A49
JATG TMS	B48
JATG TDO	A48

-6V	A6,B6 A7,B7
+6V	A8,B8 A9,B9
STBY 5V	A33,B33 A34,B34

CN040			
TDI	3	TDI FPGA2 ROM	5/5
TDO	4	TMS	4/5,5/5
TMS	5	TCK	4/5,5/5
TCK	6		

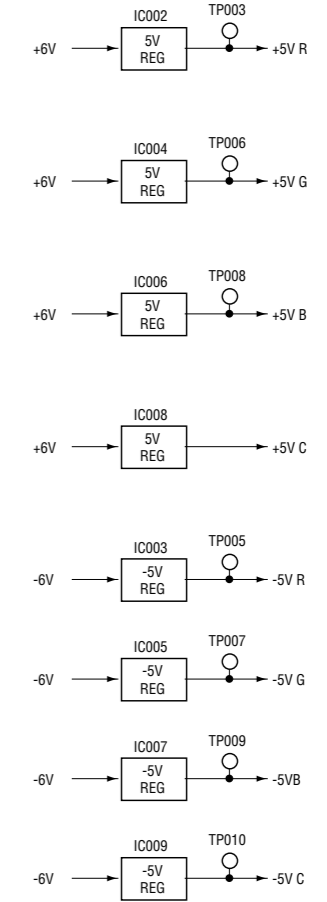
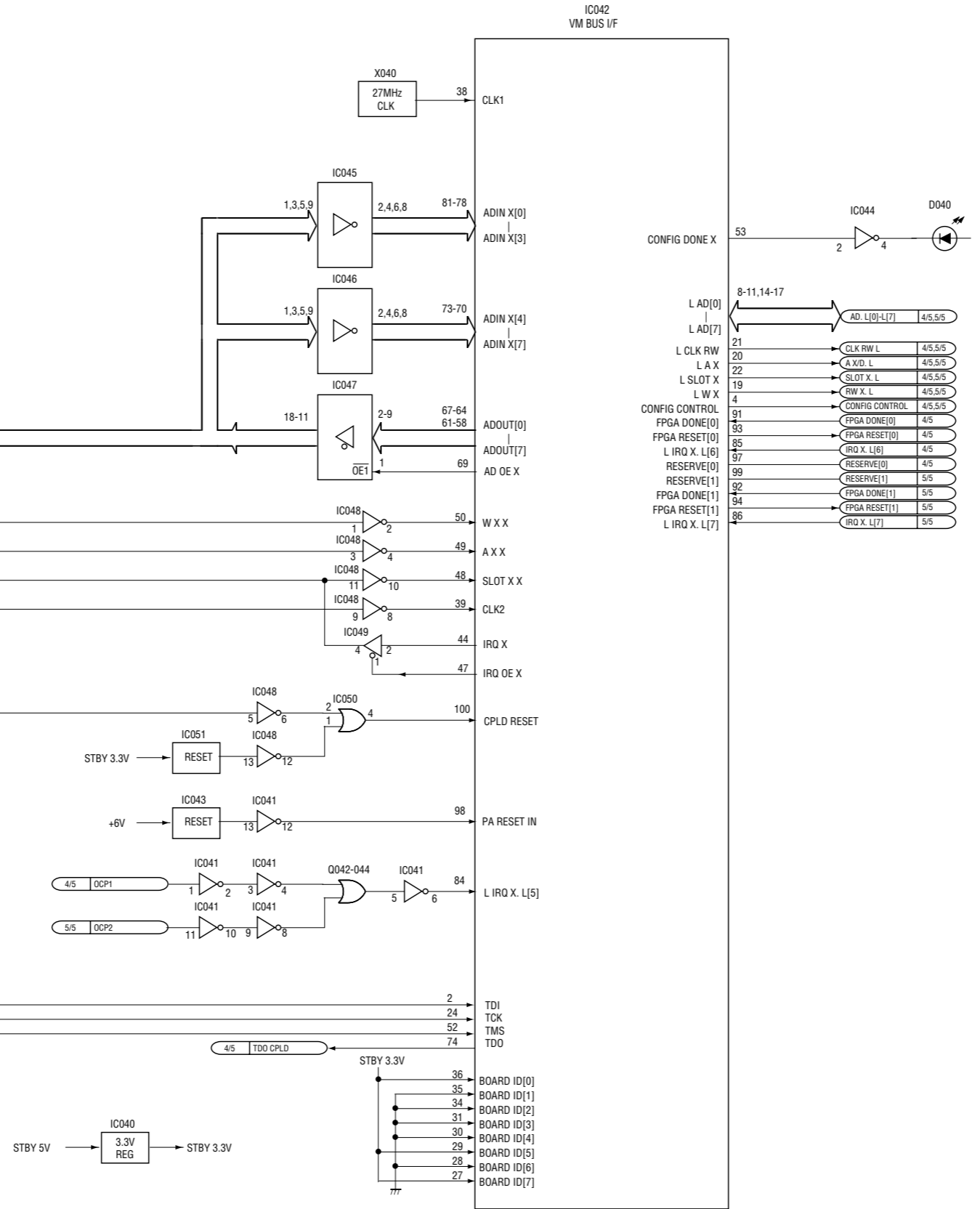

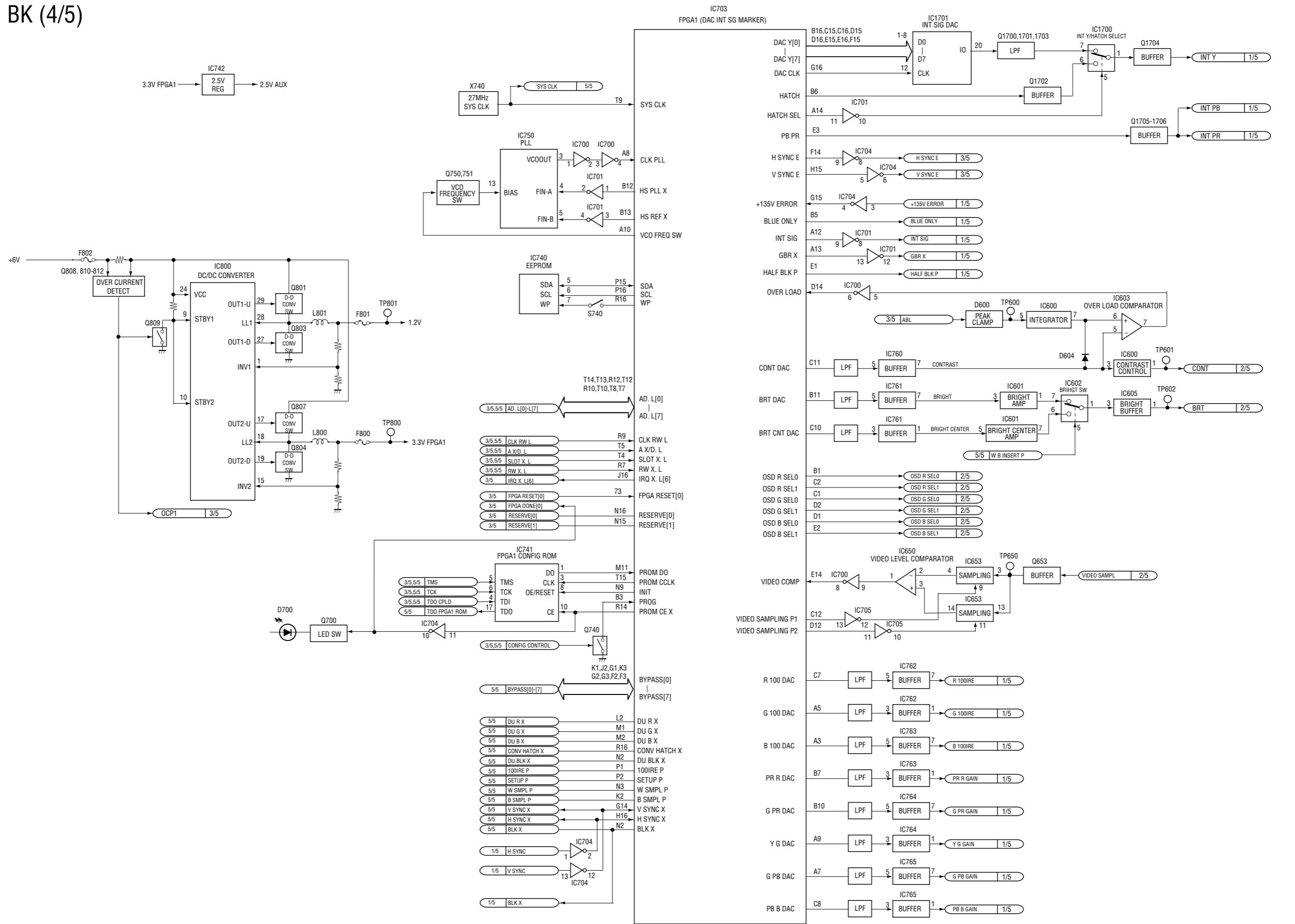

BK (5/5)

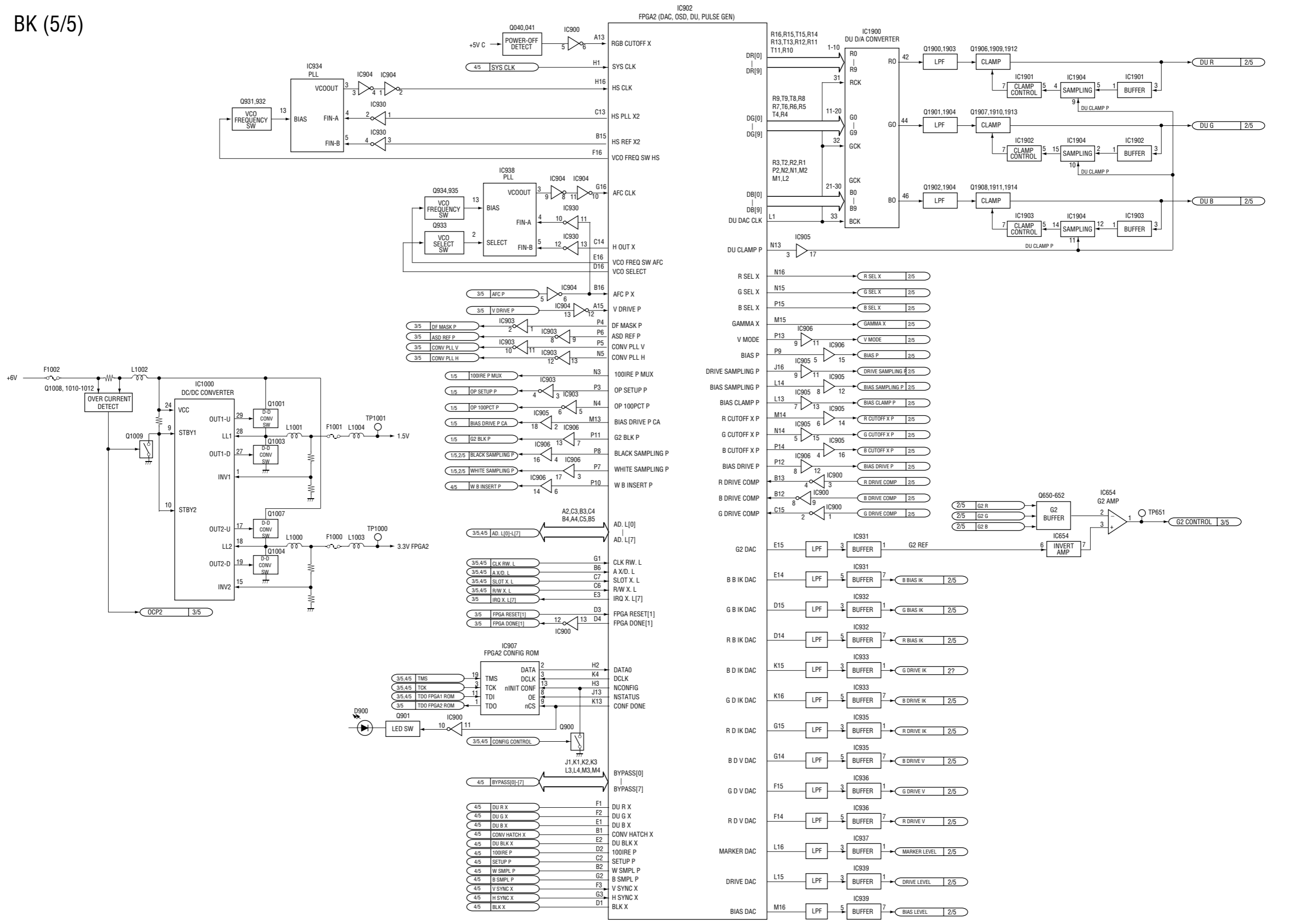

BK BOARD
CN003

TB BOARD
CN213

PA BOARD
CN201

TA BOARD
CN114

PC BOARD

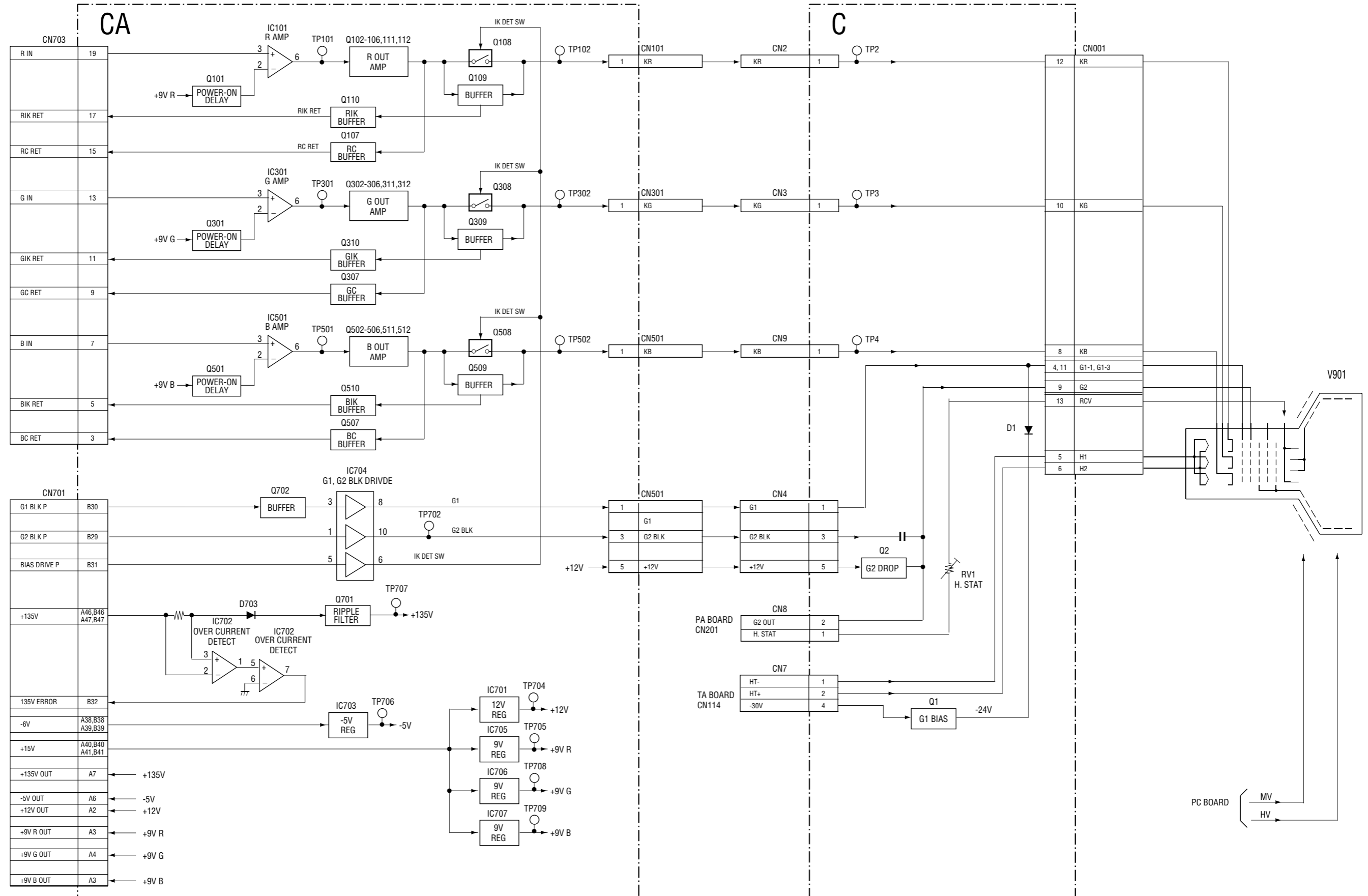

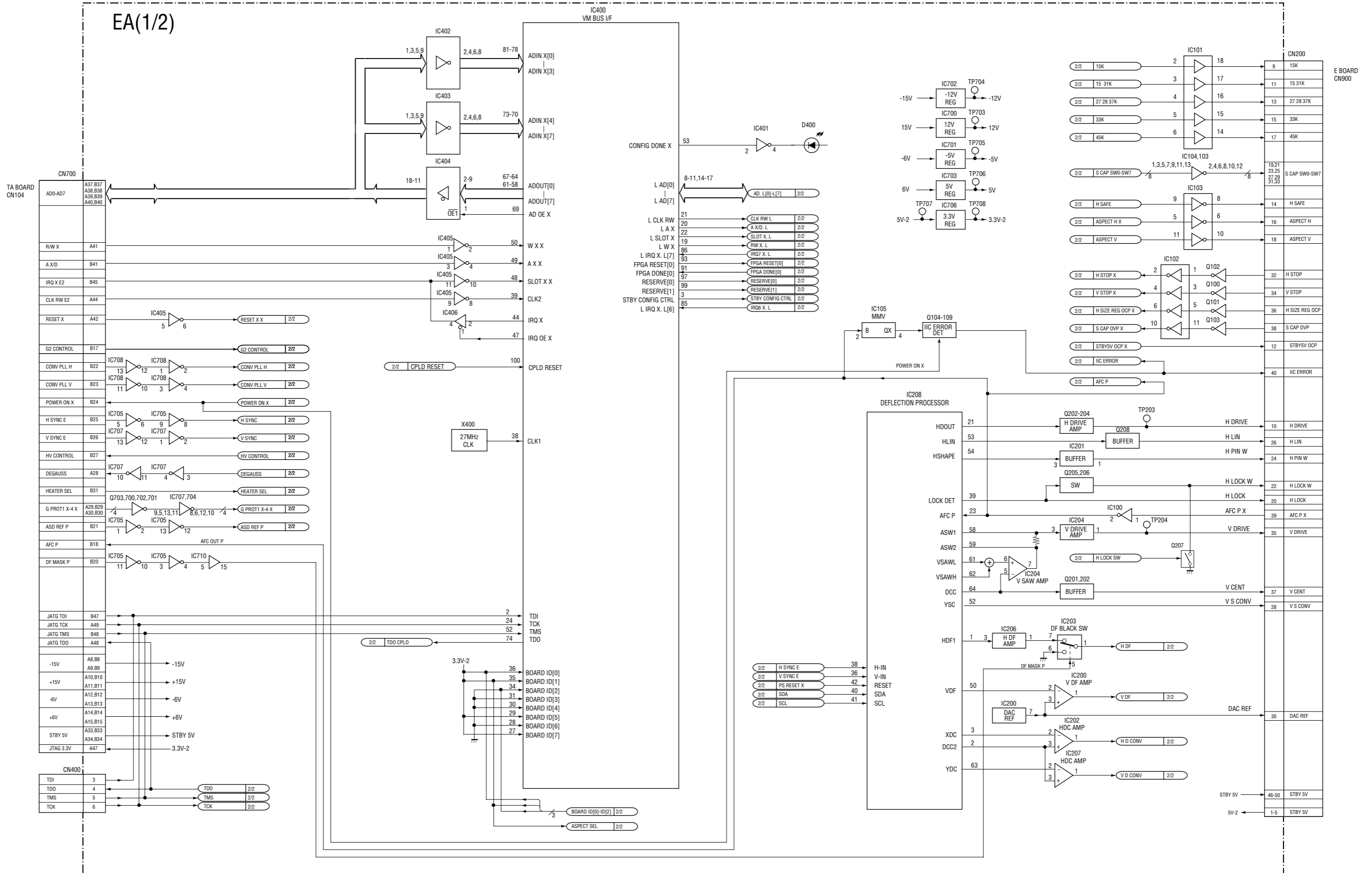

EA (2/2)

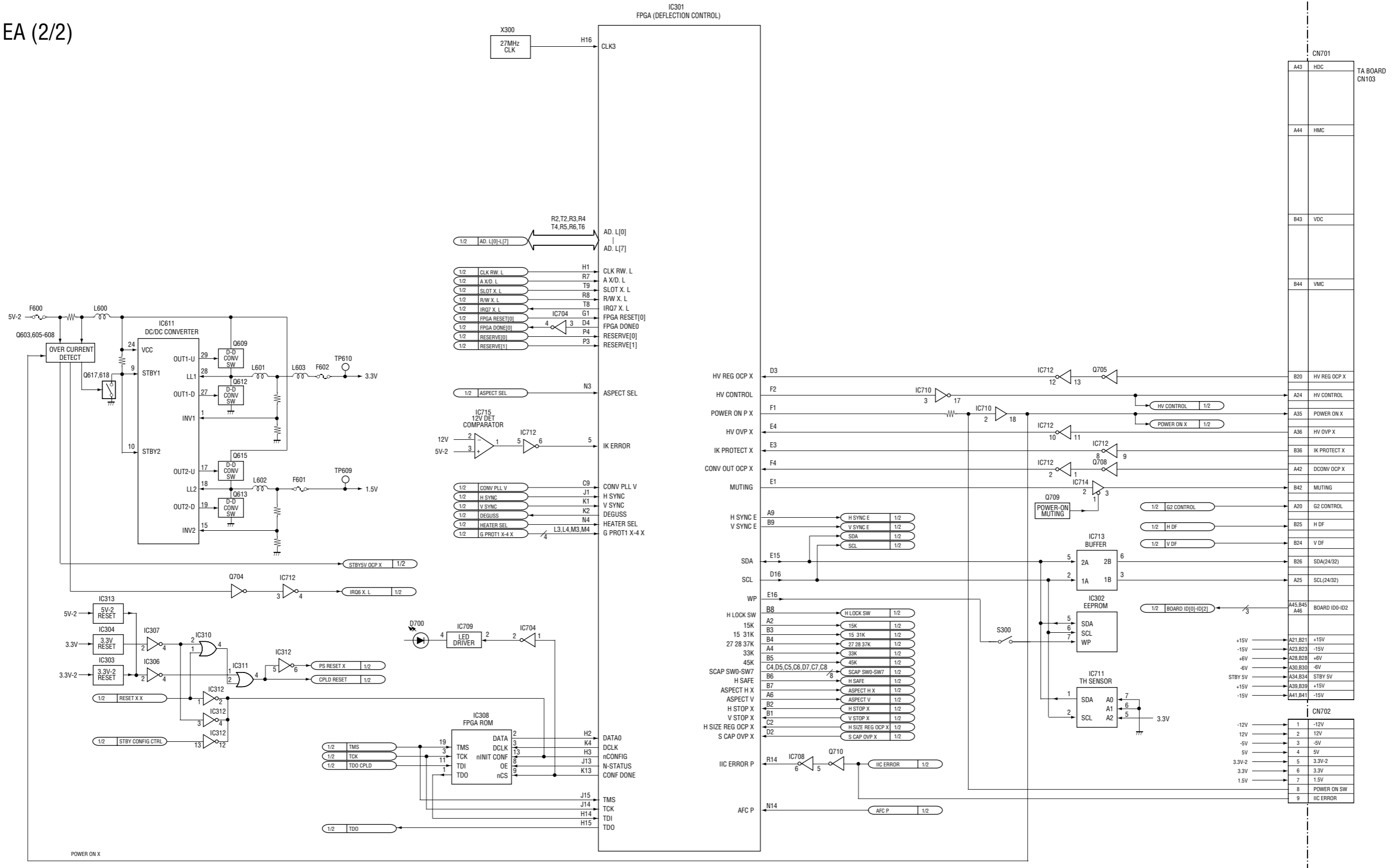

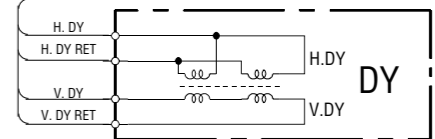
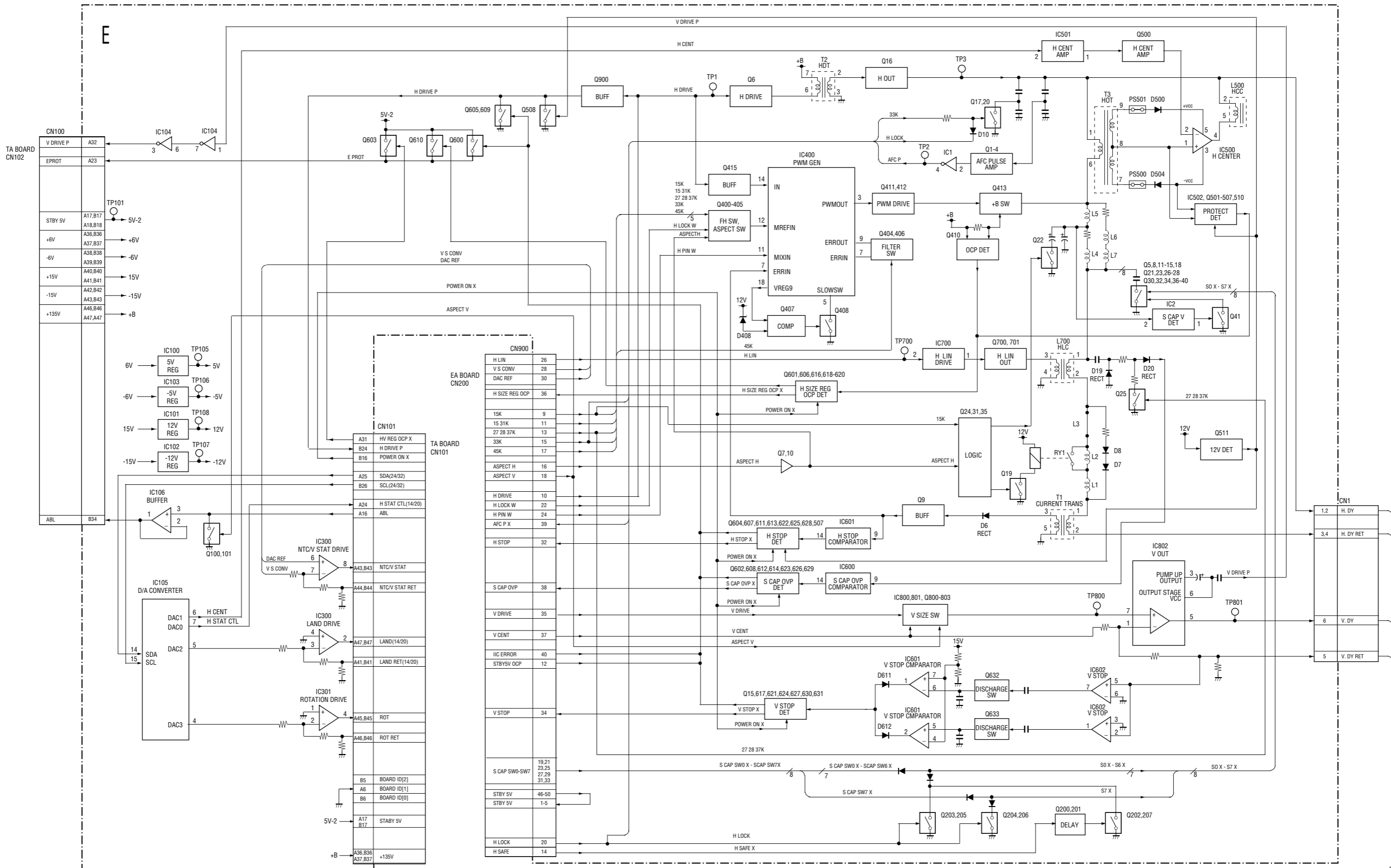

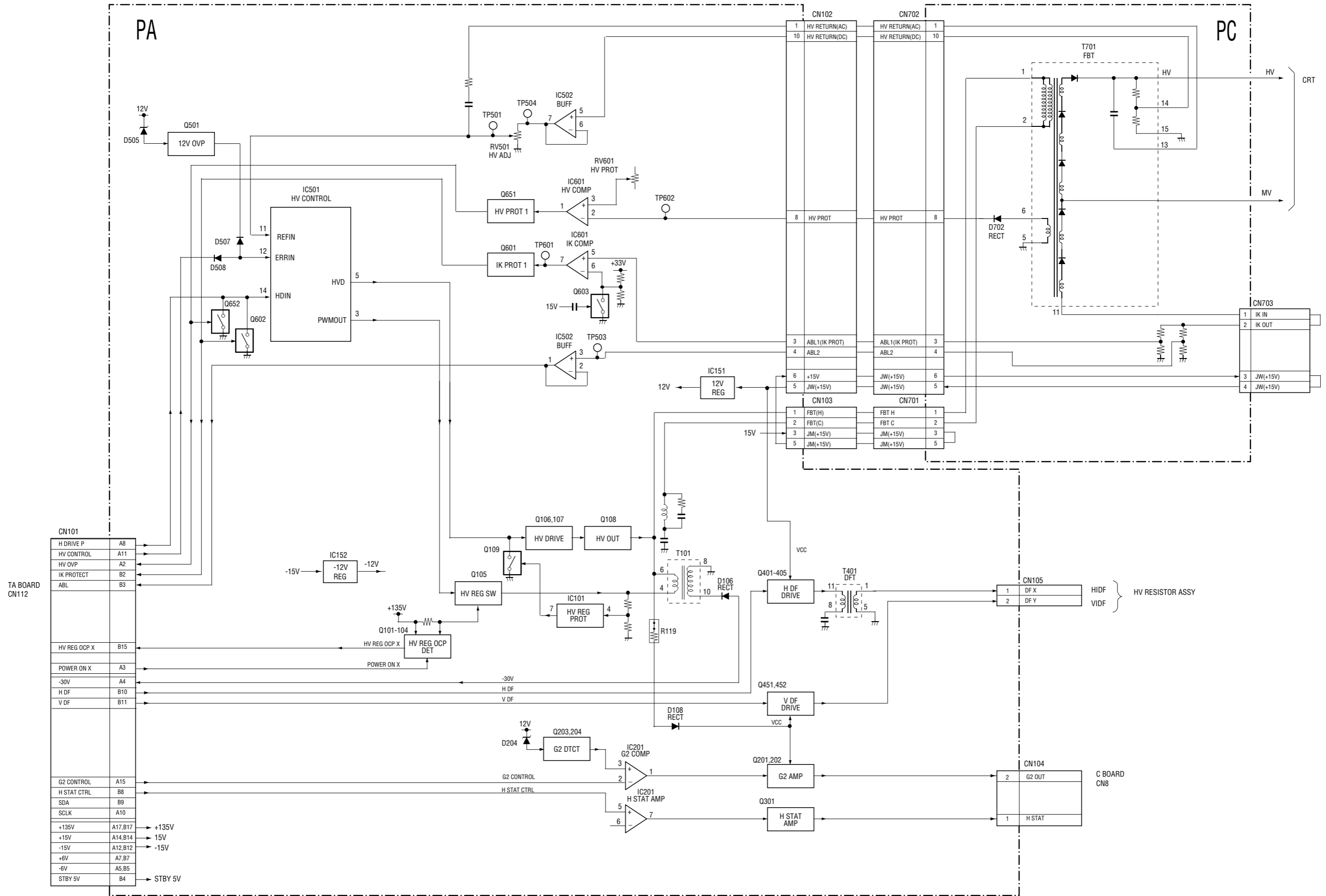

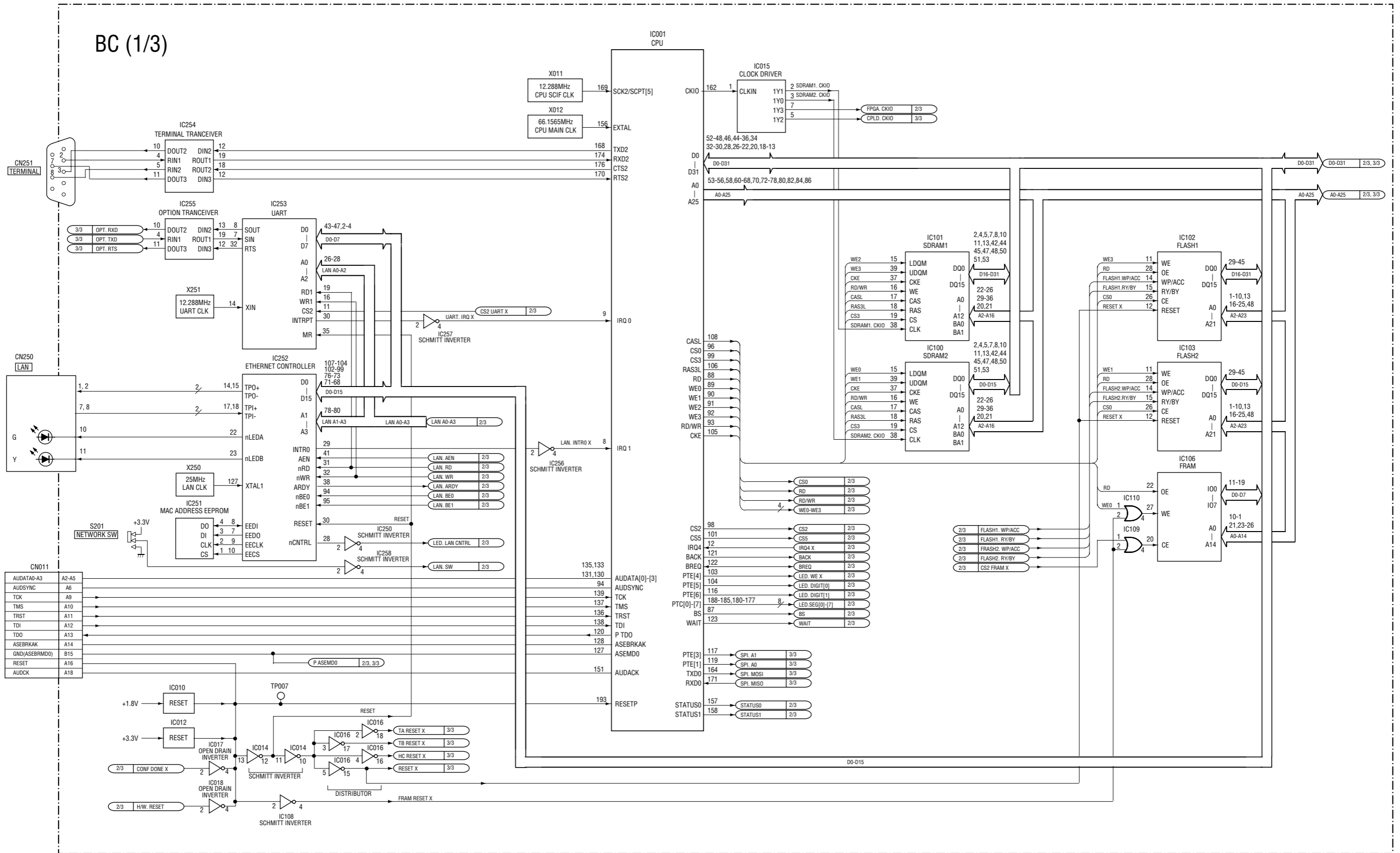

BC (2/3)

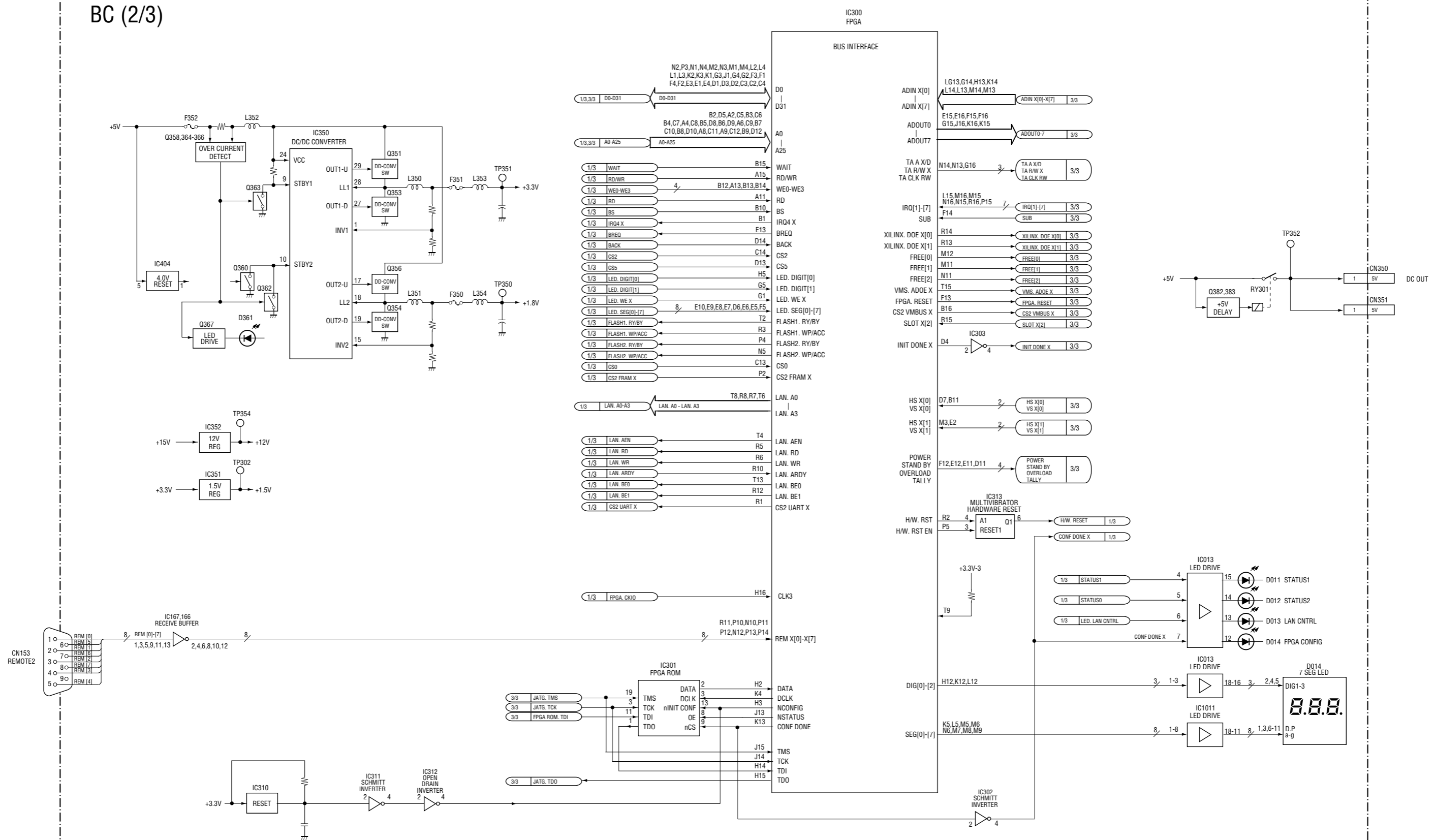

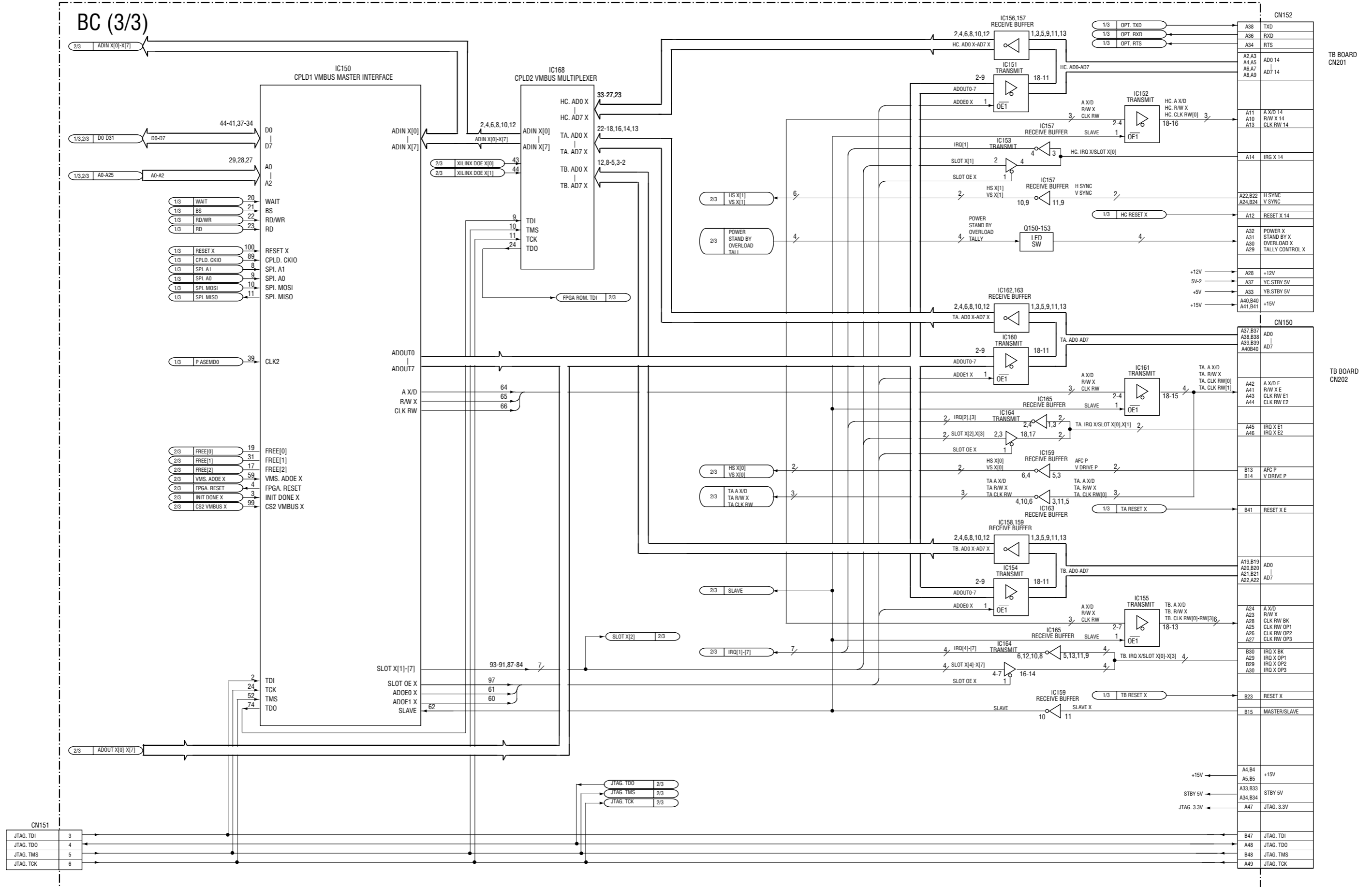

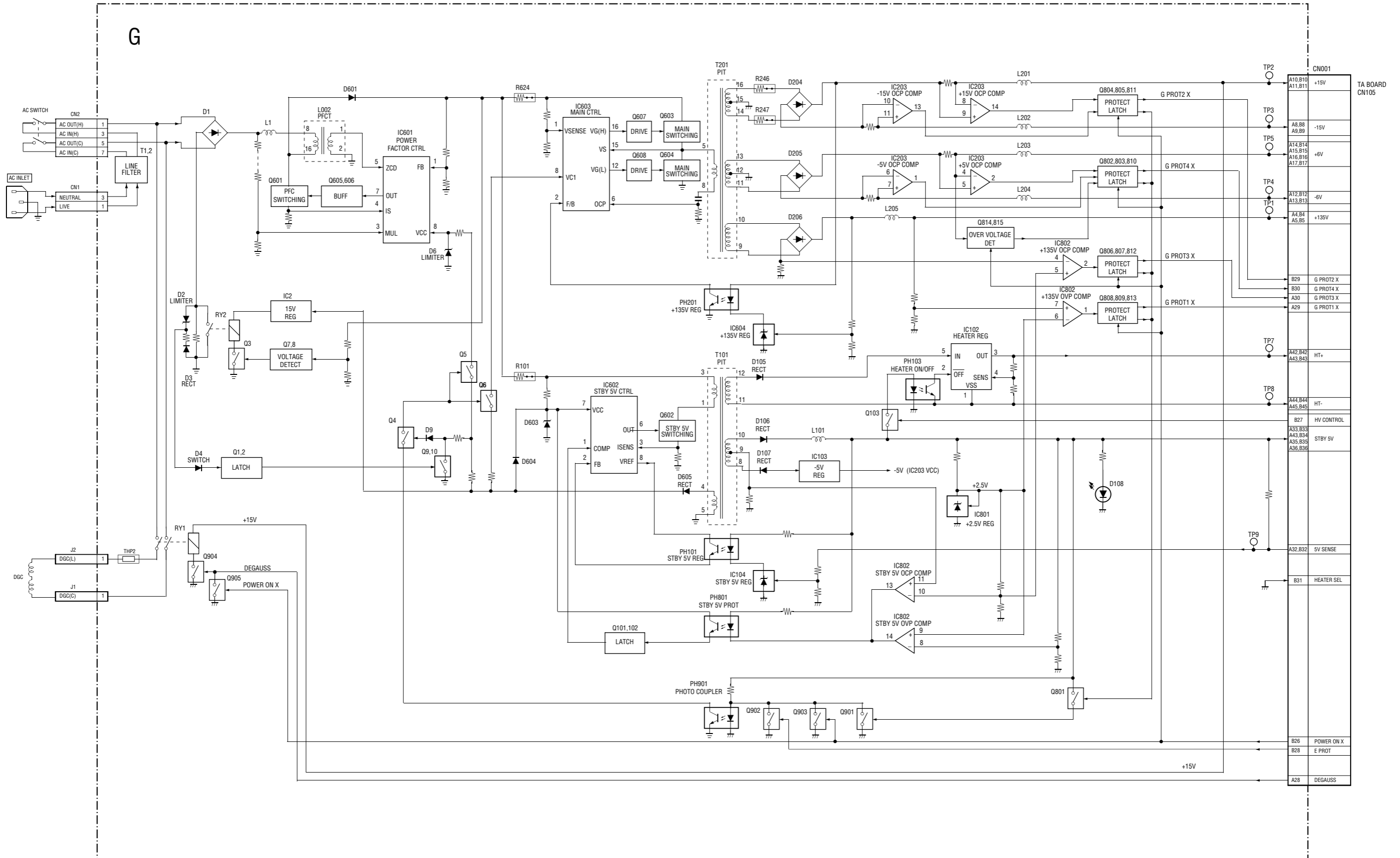

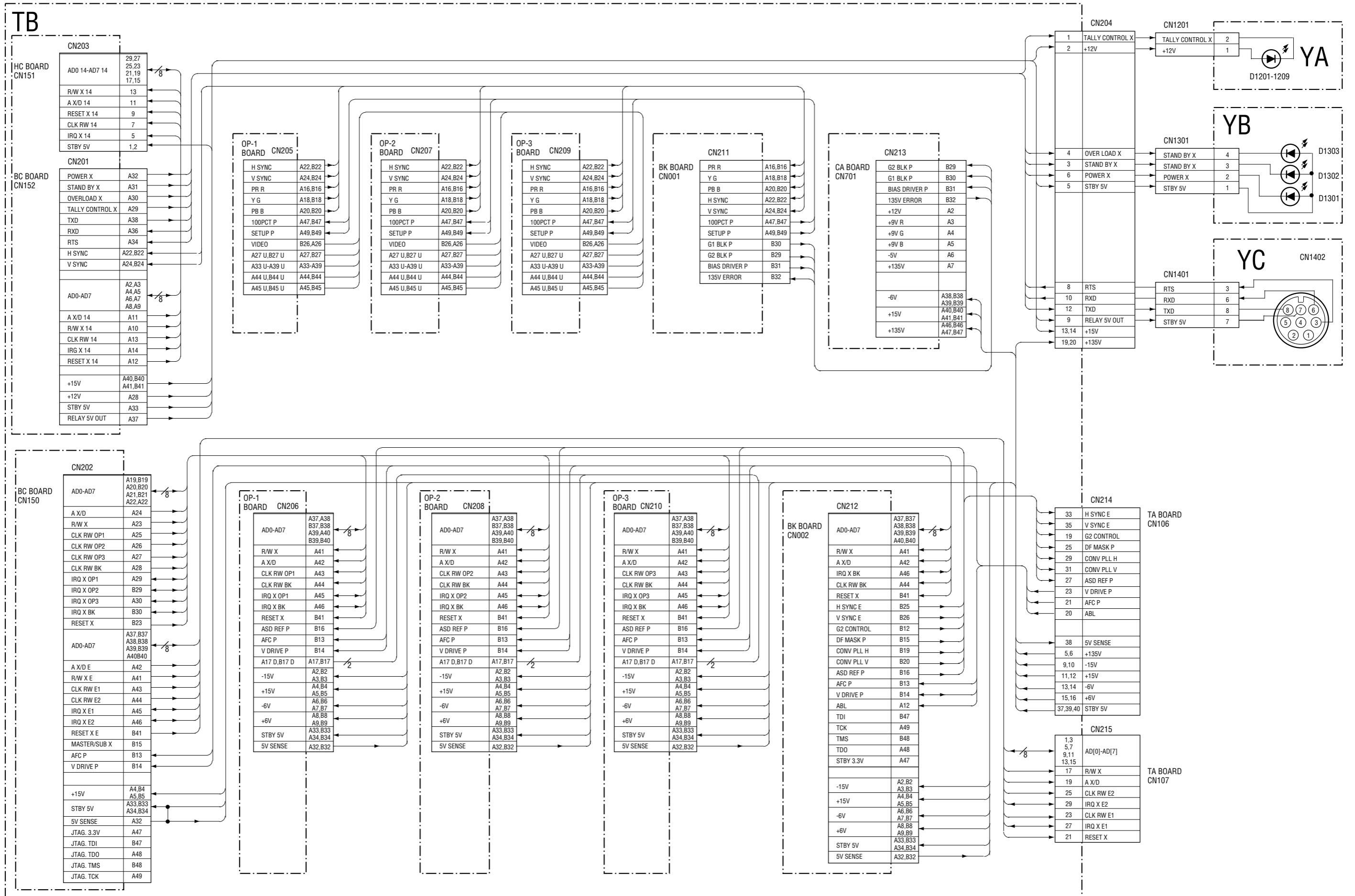

TA

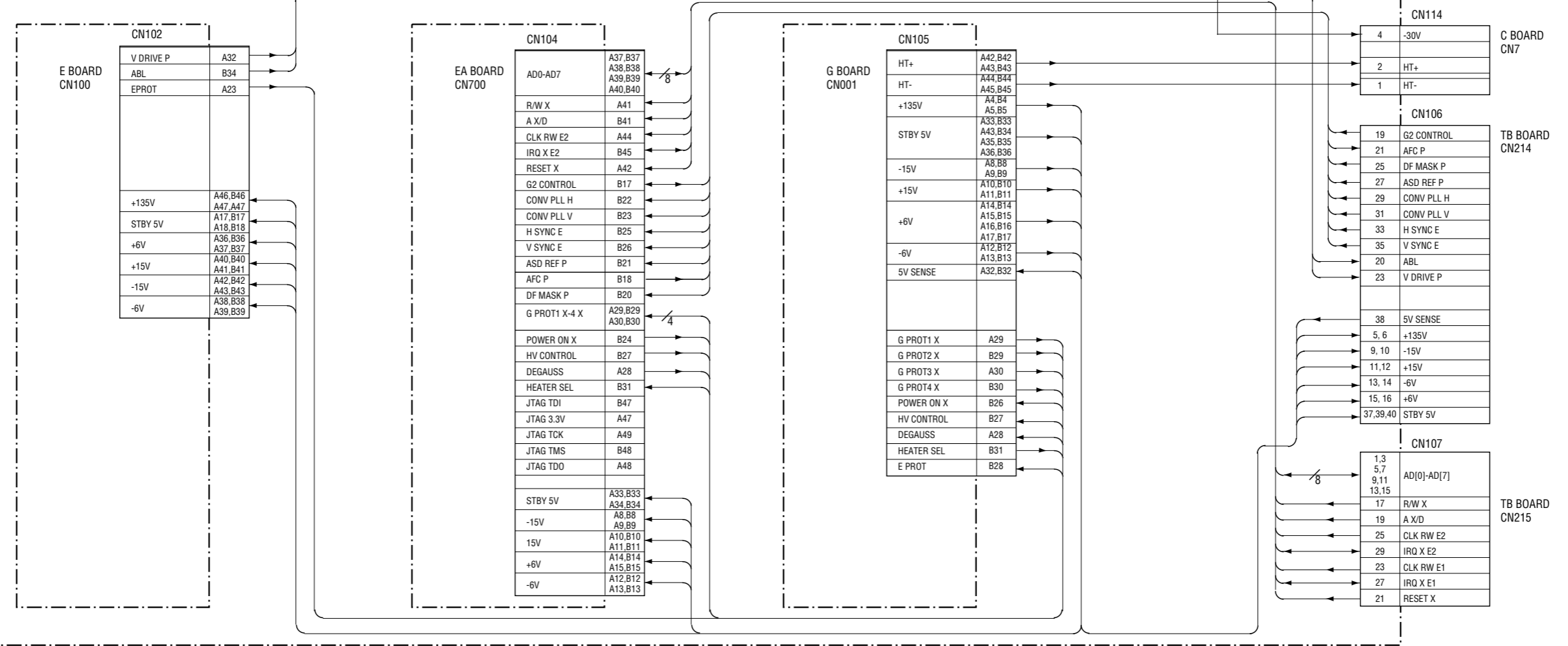
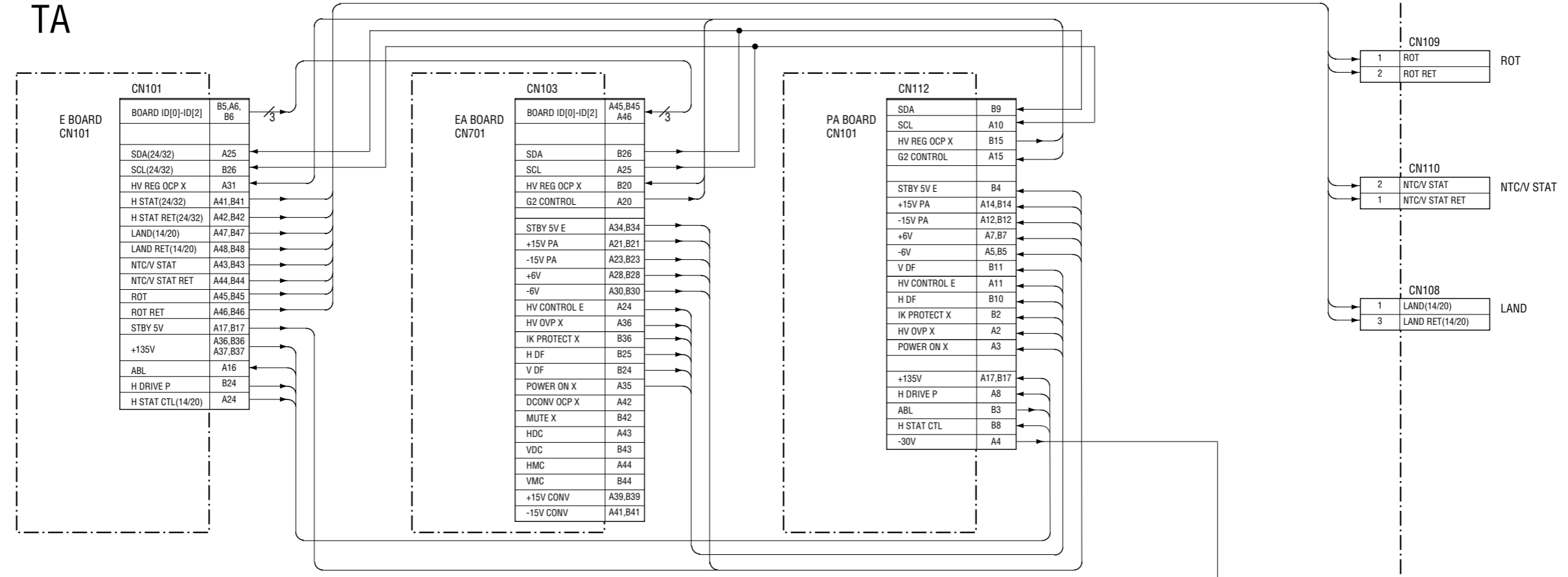

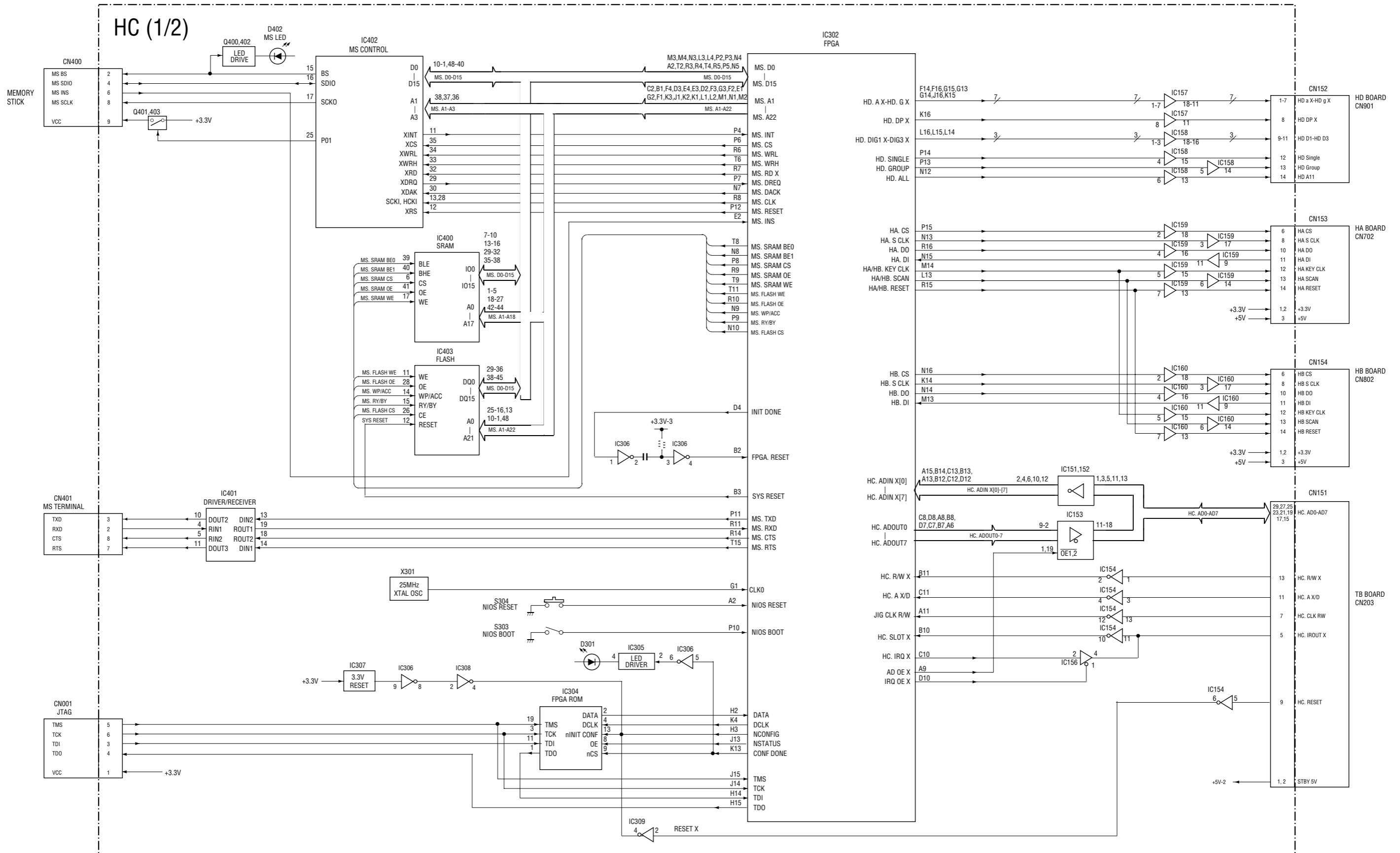

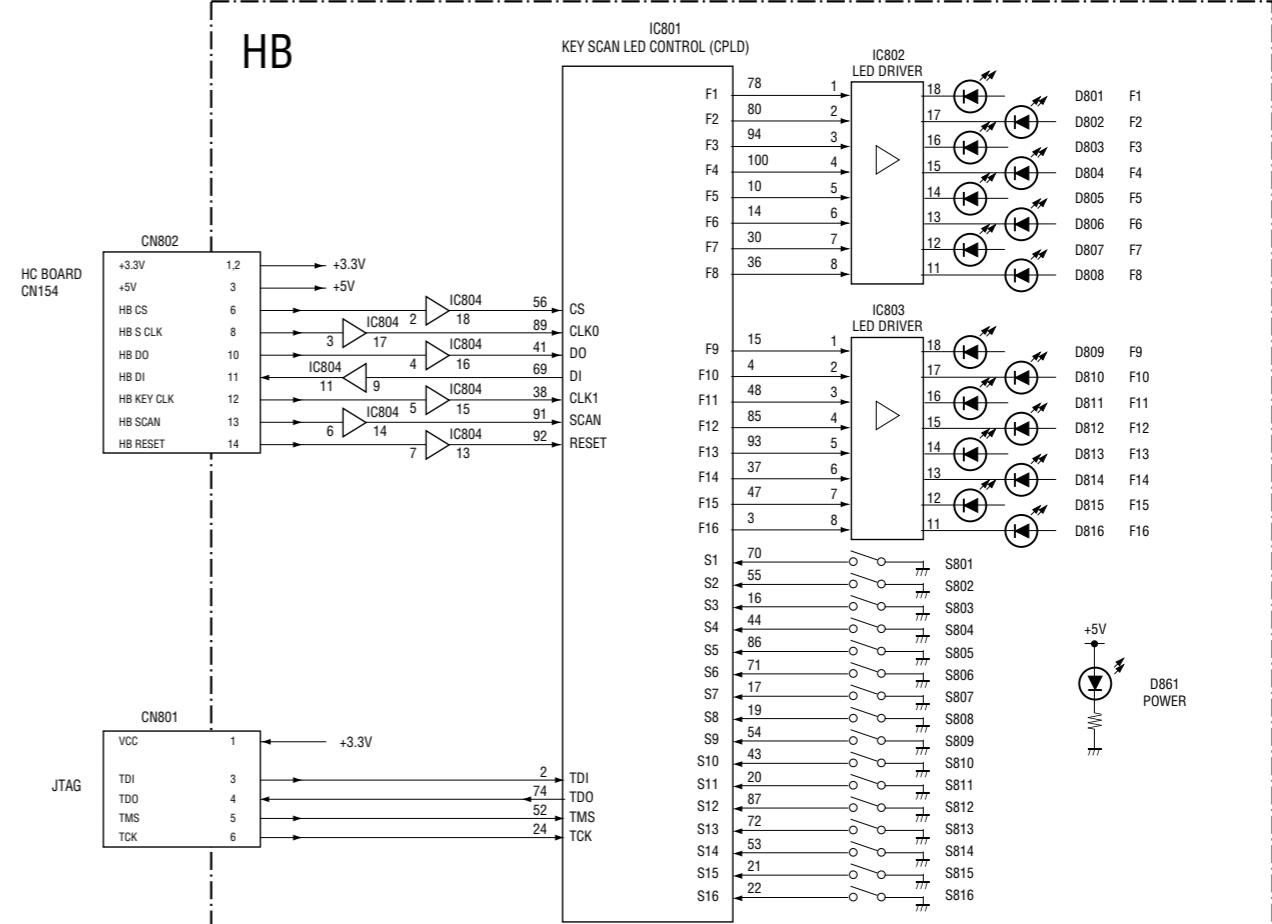
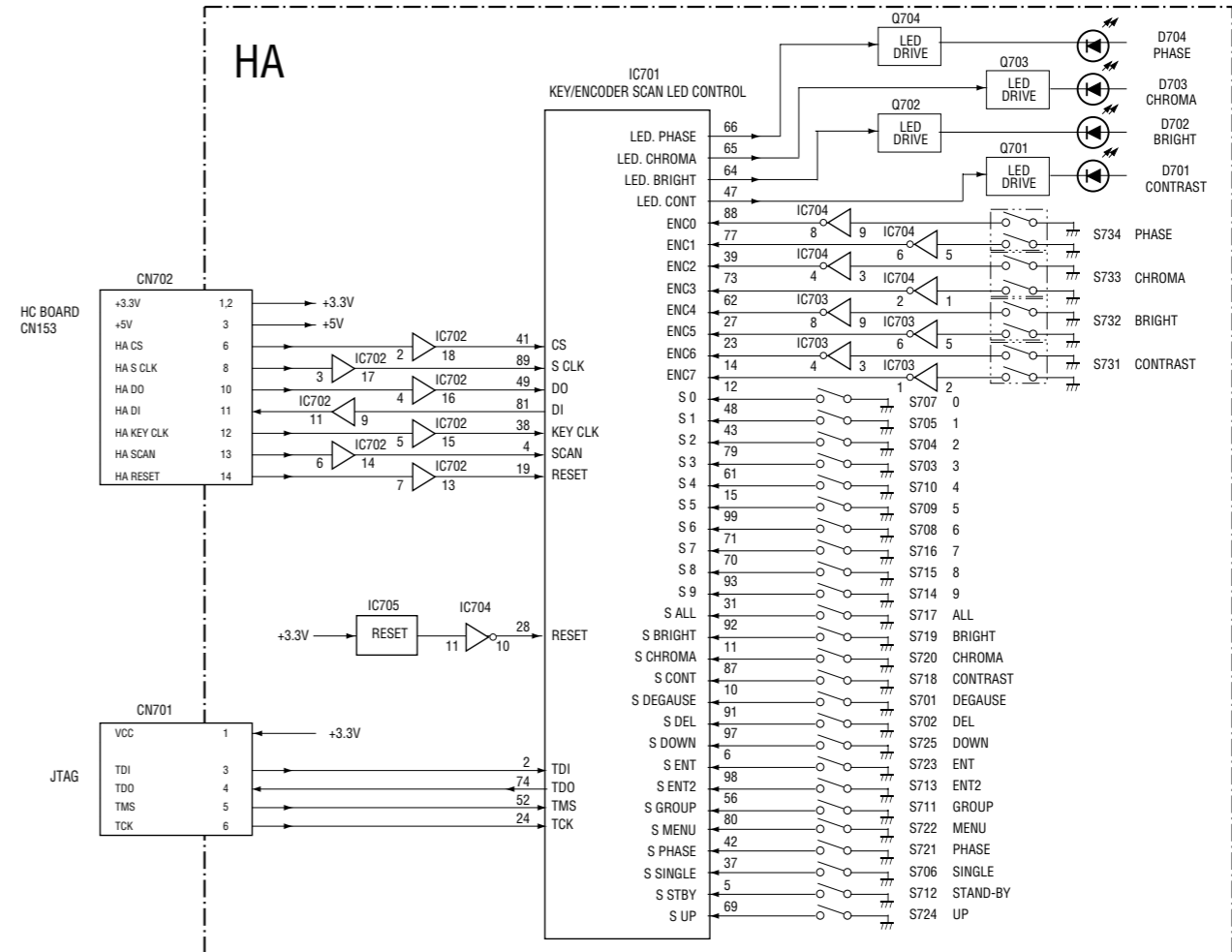
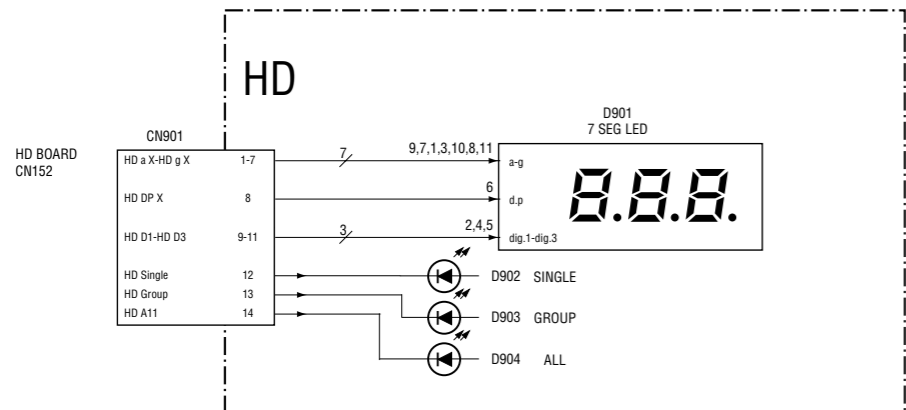
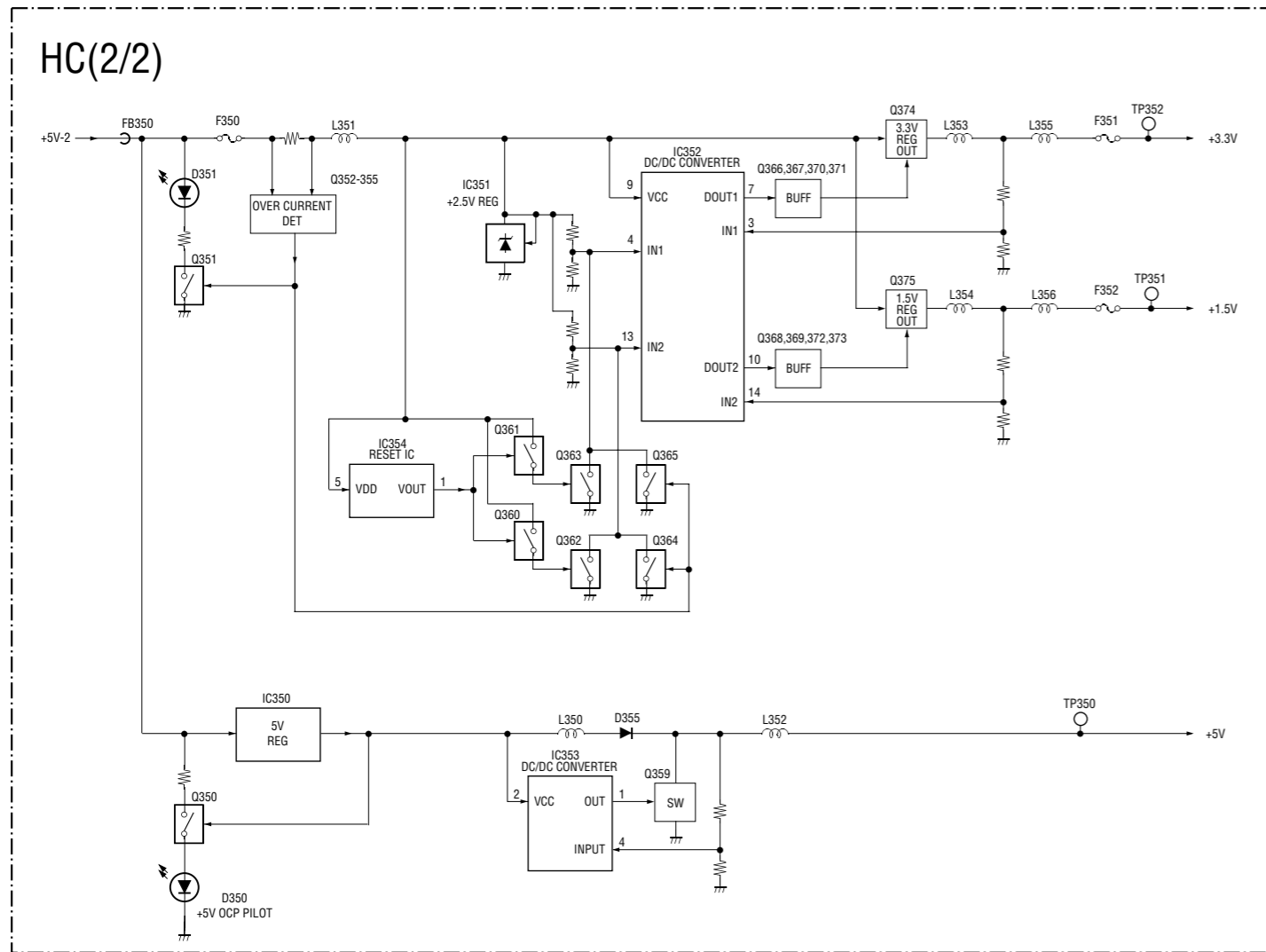





Section 8 Schematic Diagrams

Board Name	Function	Page
BC	MAIN CPU	8-4
BK	VIDEO PROCESSOR	8-11
C	R, G, B OUT	8-26
CA	R, G, B AMP	8-27
E	H/V OSC	8-28
EA	DEFLECTION PROCESSOR	8-30
G	SWITCHING REGULATOR	8-35
HA	KEY/ENCODER SCAN LED CONTROL	8-37
HB	KEY SCAN LED CONTROL	8-38
HC	MAIN CPU	8-39
HD	7 SEG LED	8-43
PA	H/V CONTROL	8-44
PC	FLYBACK TRANSFORMER	8-45
TA	MOTHER BOARD	8-46
TB	MOTHER BOARD	8-47
YA	TALLY LED	8-48
YB	PANEL LED	8-48
YC	OPTION JACK	8-48

- The components marked  in this schematic diagram have been carefully factory-selected for each set in order to satisfy regulations regarding X-ray radiation.
- When replacing components marked , make the necessary adjustments indicated. If results do not meet the specified value, change the component marked  and repeat the adjustment until the specified value is achieved.
- When replacing a part shown in the table below, be sure to perform the related adjustment.

The components identified marked  are critical for safety.
Replace only with the part number specified.

Les composants identifiés par la marque  sont critiques pour la sécurité.
Ne les remplacer que par une pièce portant le numéro spécifié.



BOARD NAME	REF. NO.
BK	IC009, R604, R605
G	IC604
PA	D601, D608, D609, D651, D652, D659, D660, IC501, IC502, IC601, Q601, Q602, Q651, Q652, R505, R506, R508, R509, R510, R511, R512, R514, R515, R517, R602, R603, R604, R605, R606, R607, R652, R653, R654, R655, R656
PC	D702, R701, R702, R703, R704, R705, R706, R707, T701



BOARD NAME	REF. NO.
PA	RV501, RV601

Frame (1/2) Frame (1/2)

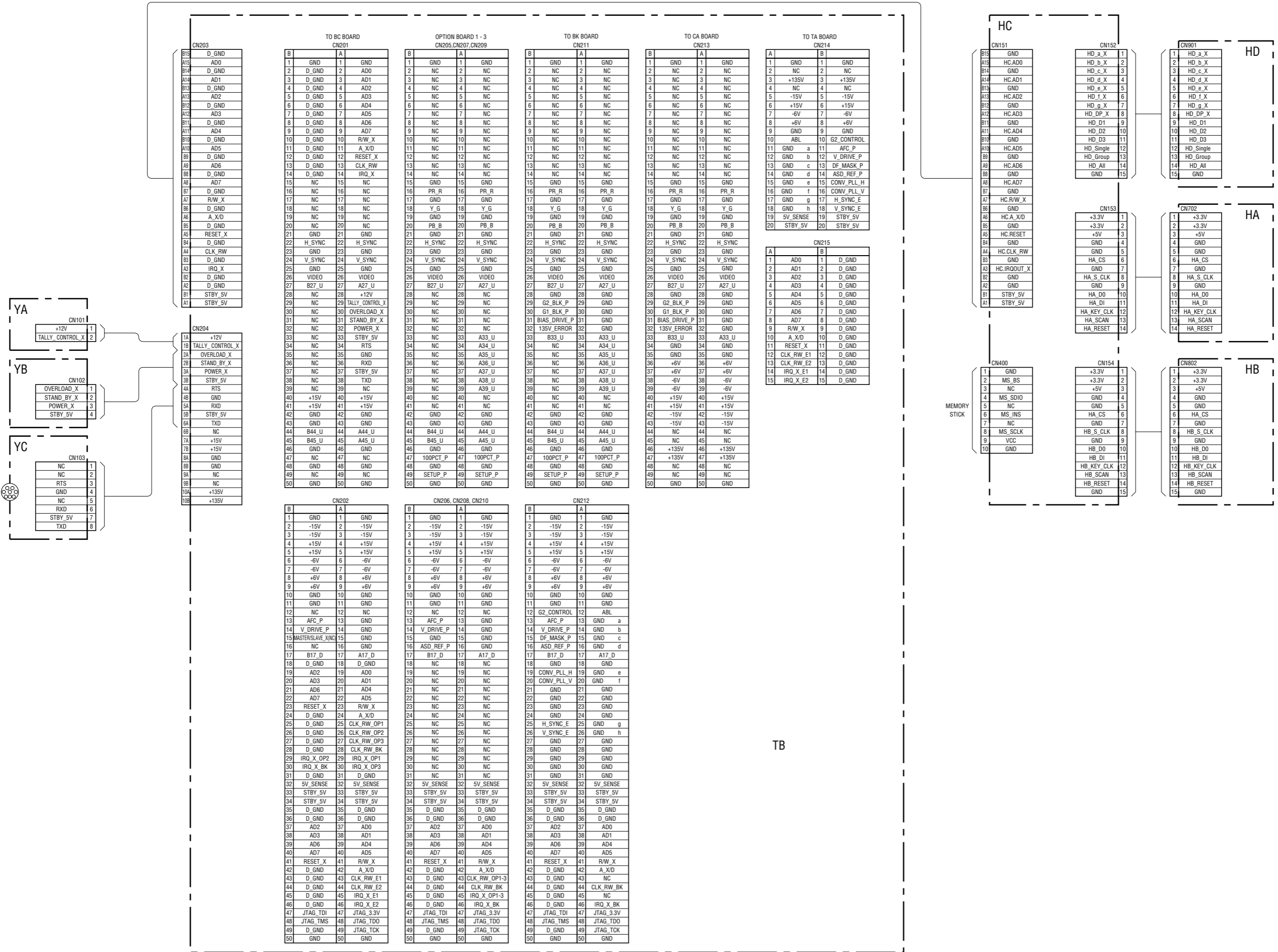

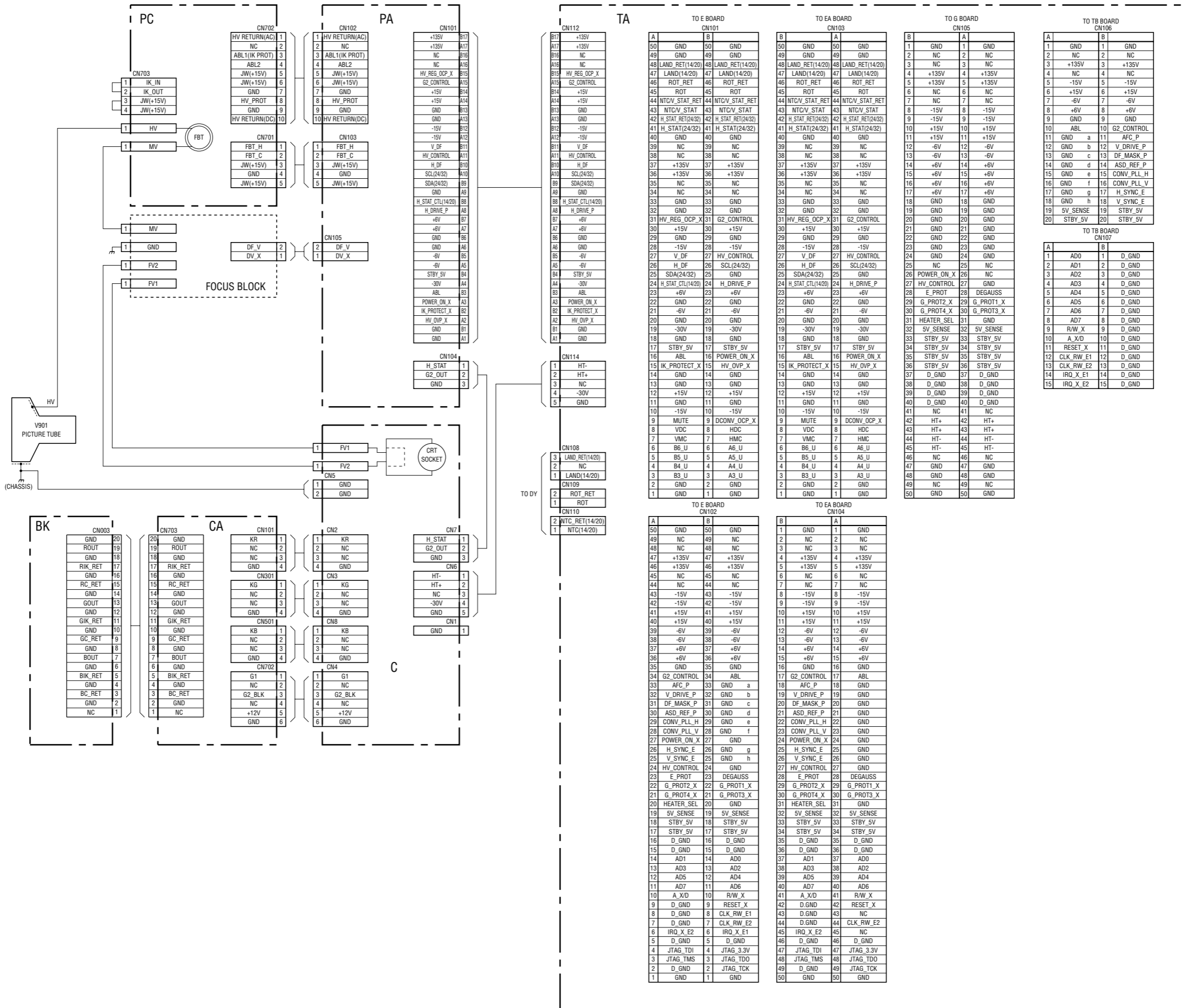

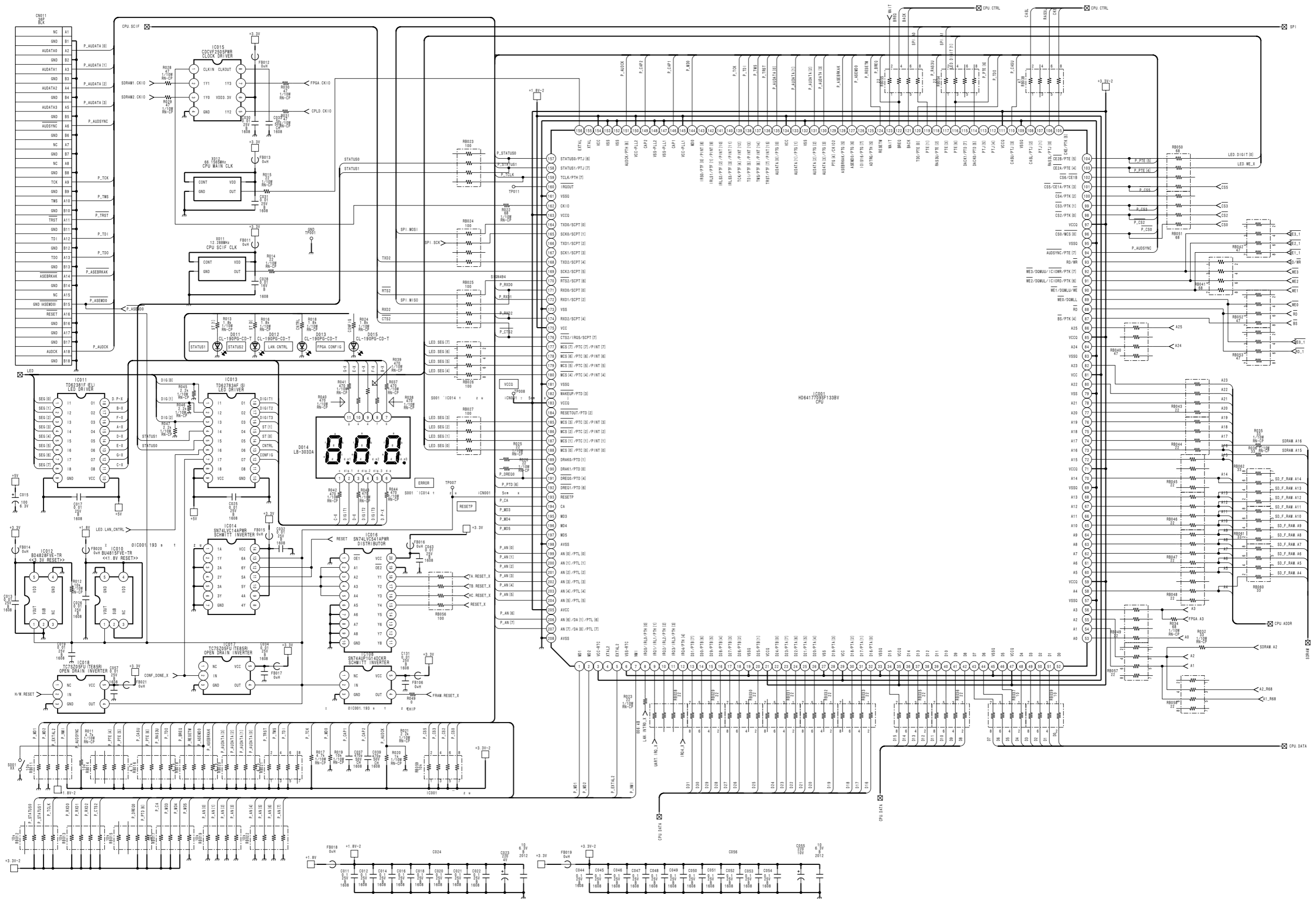

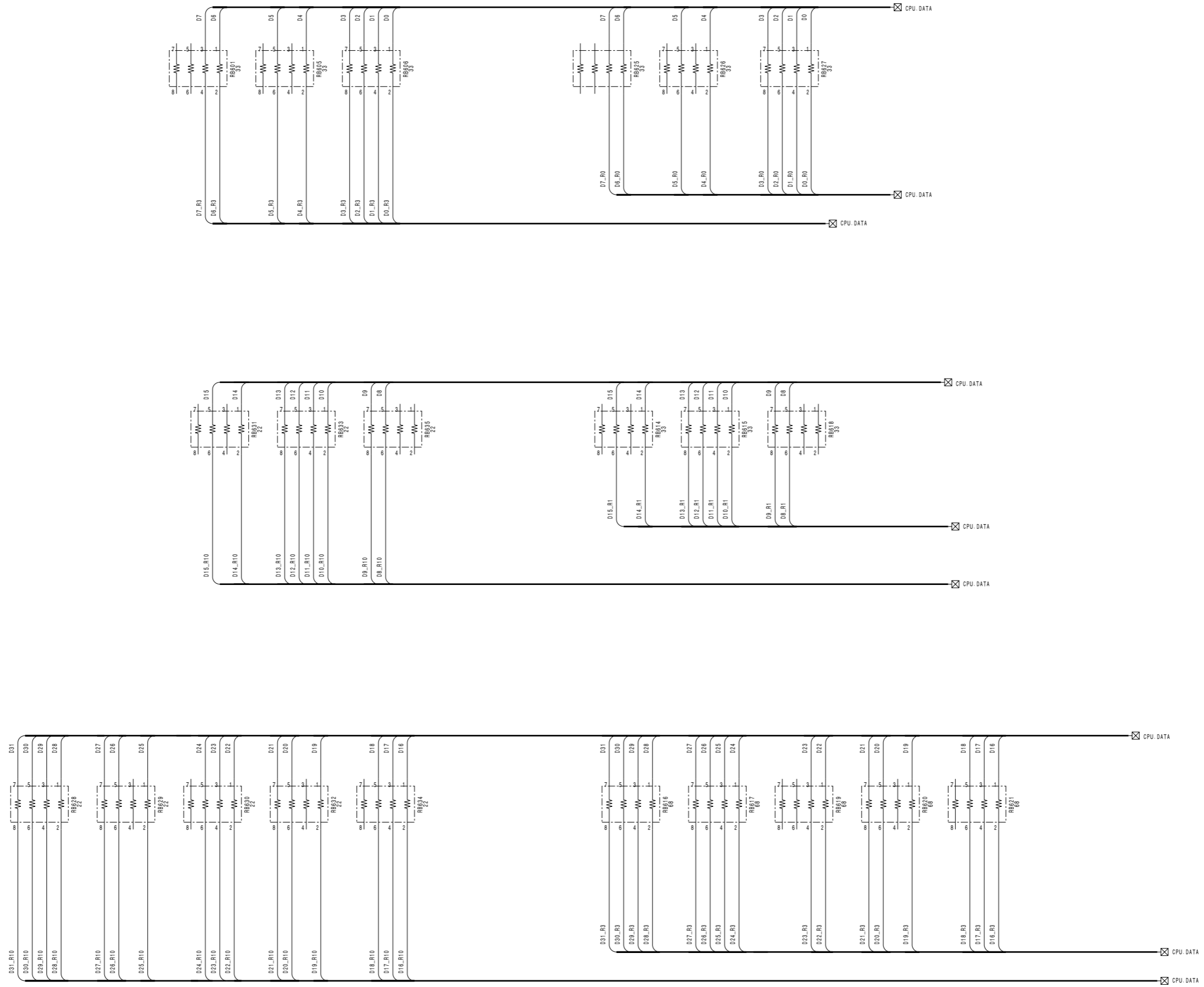

1

2

3

4

5

1

2

3

4

5

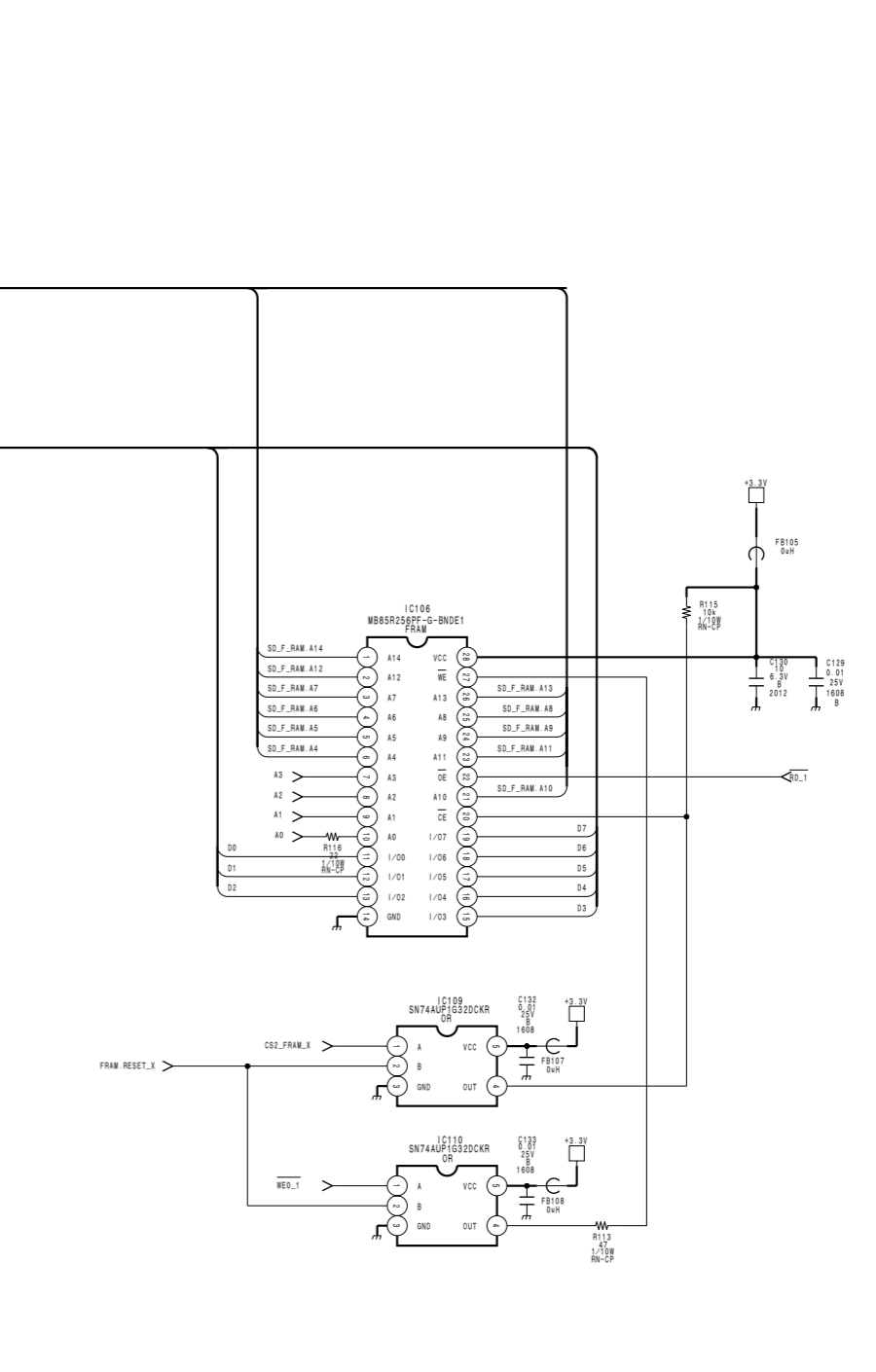
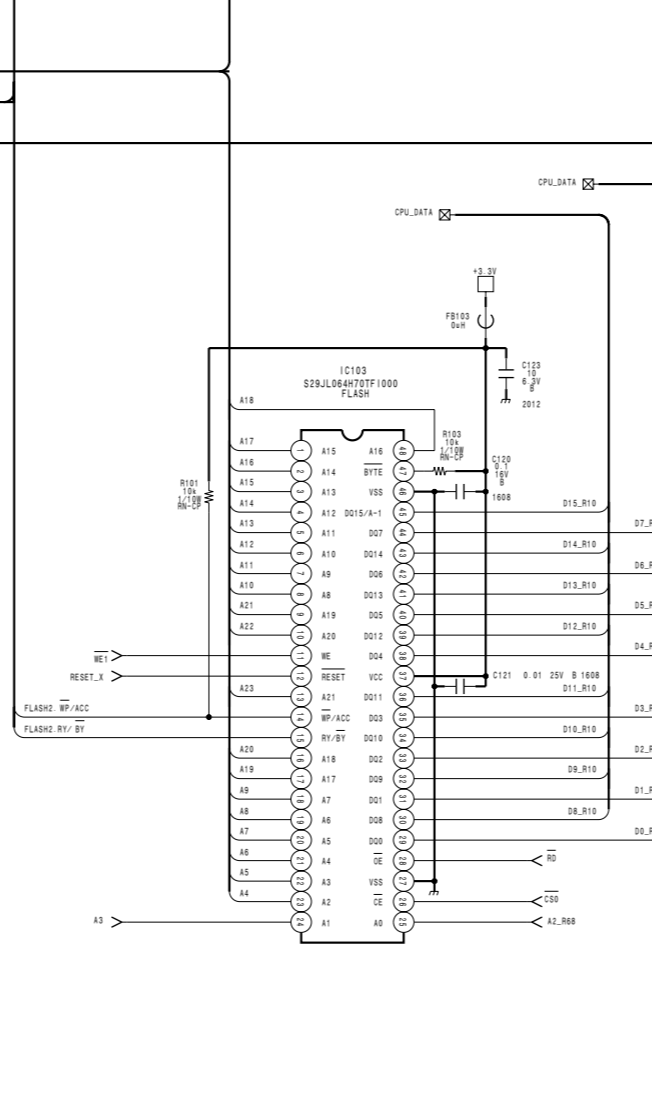
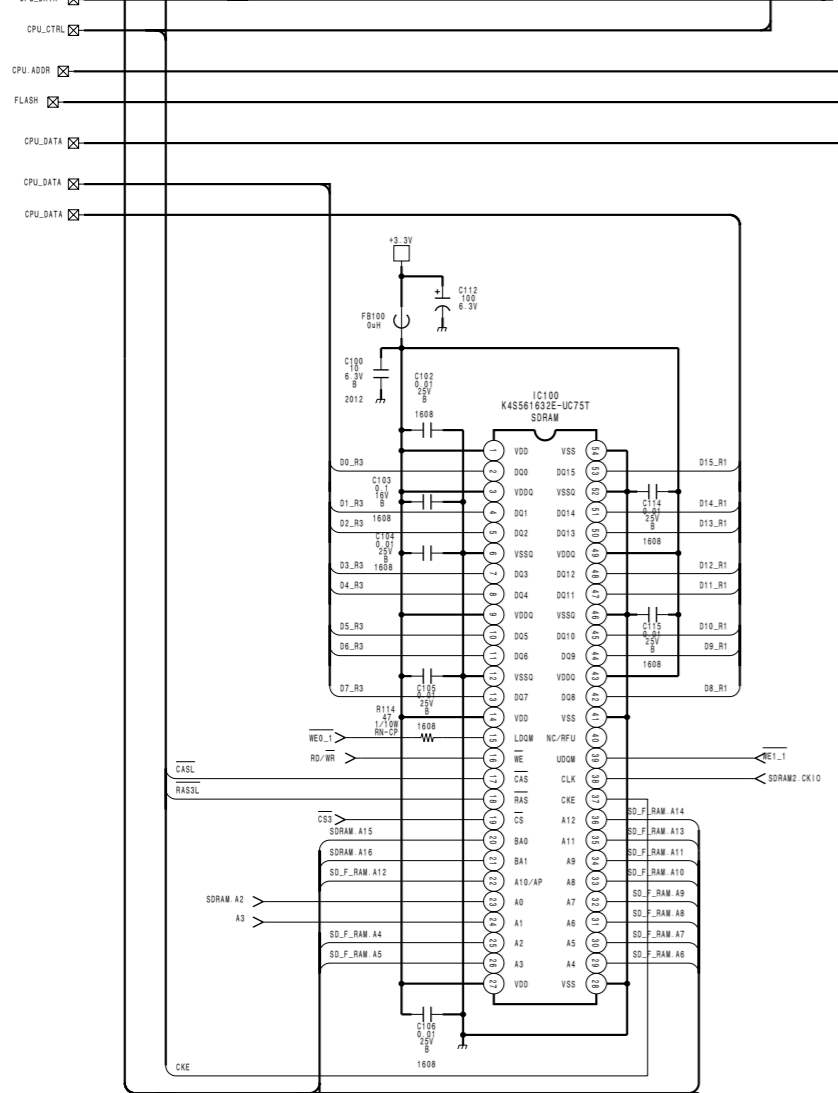
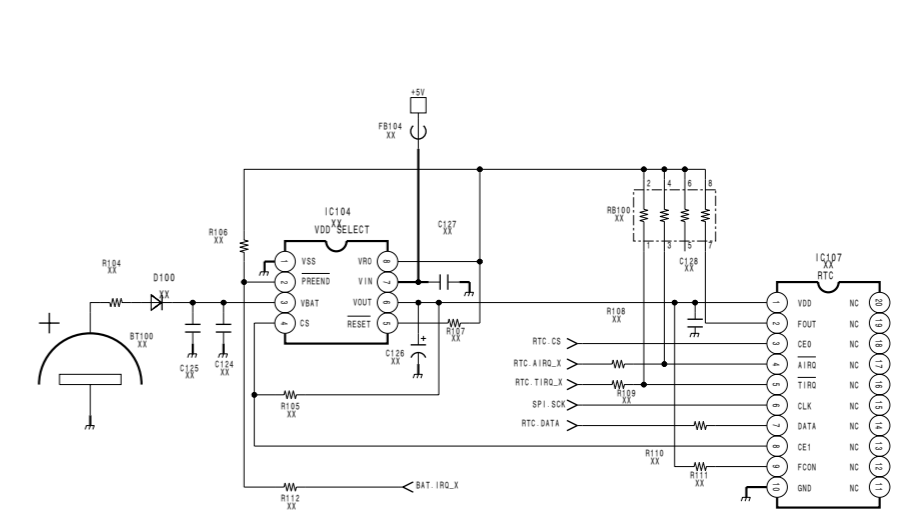
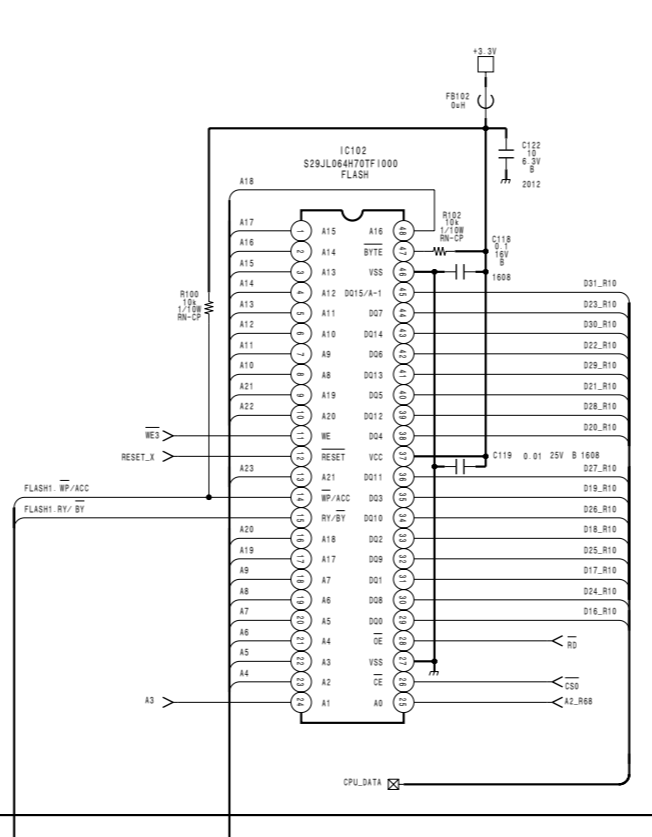
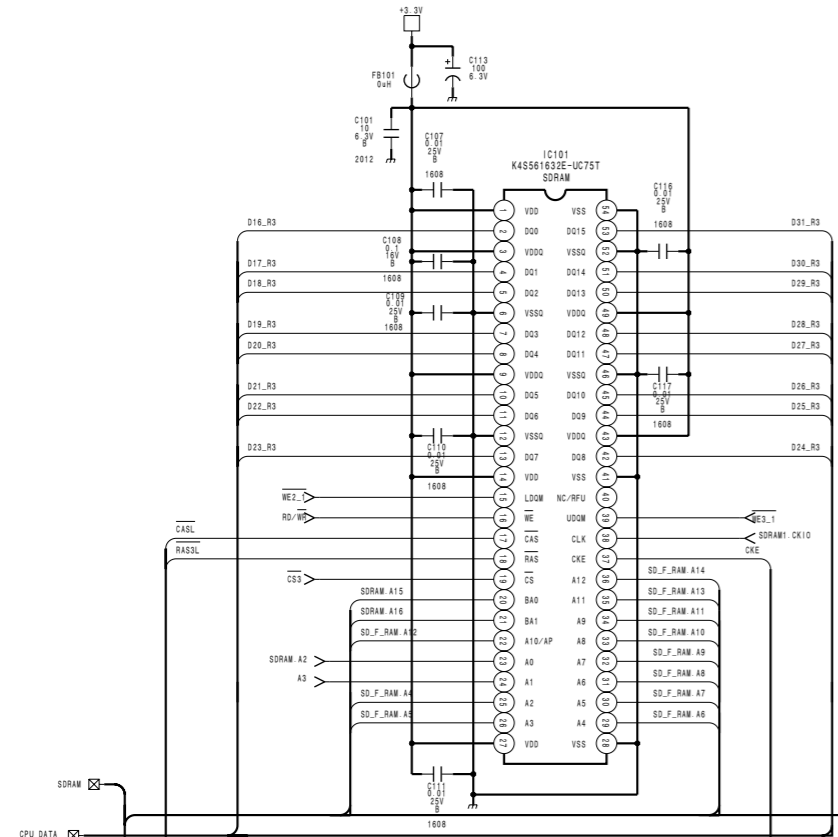

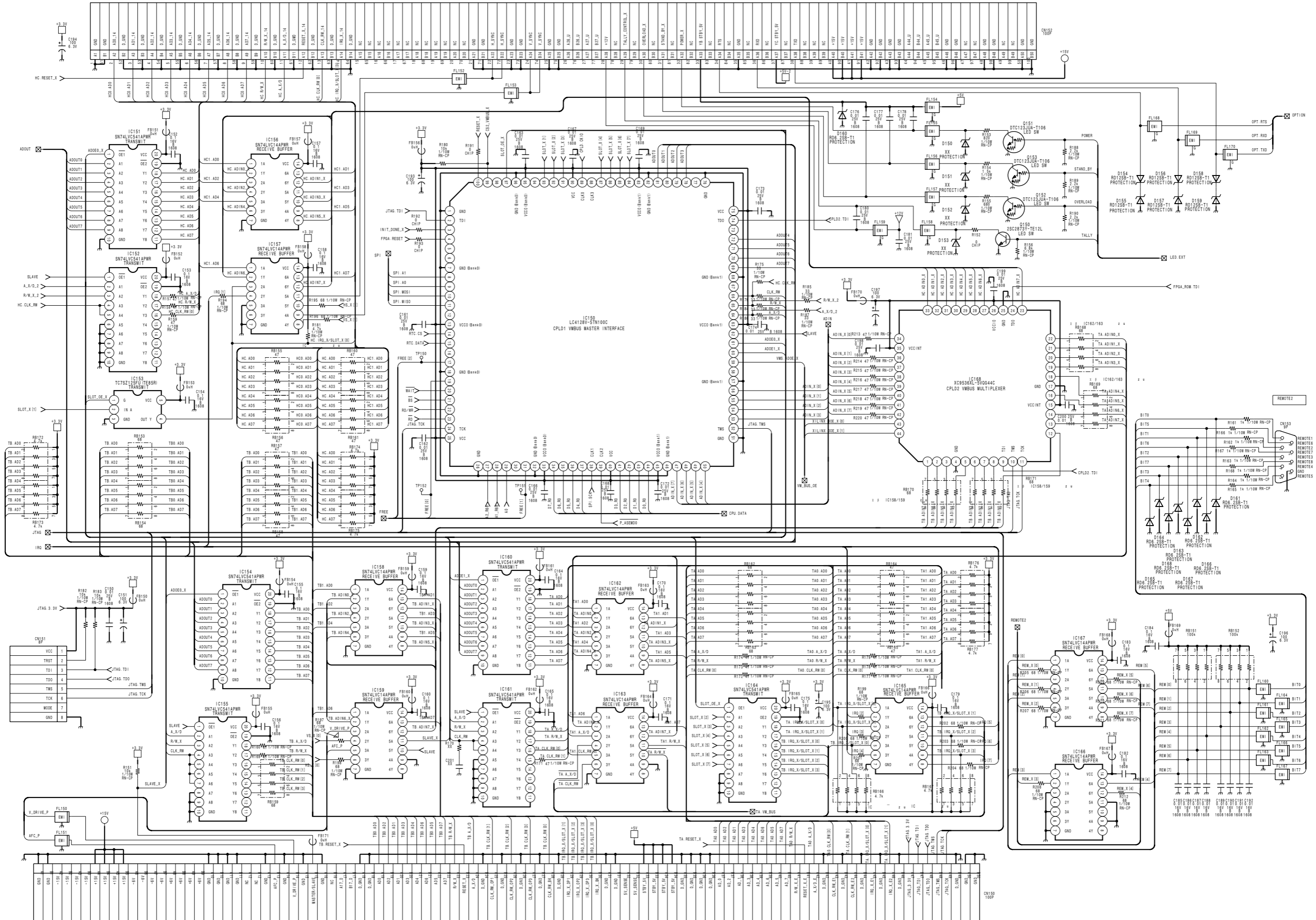

1

2

3

4

5

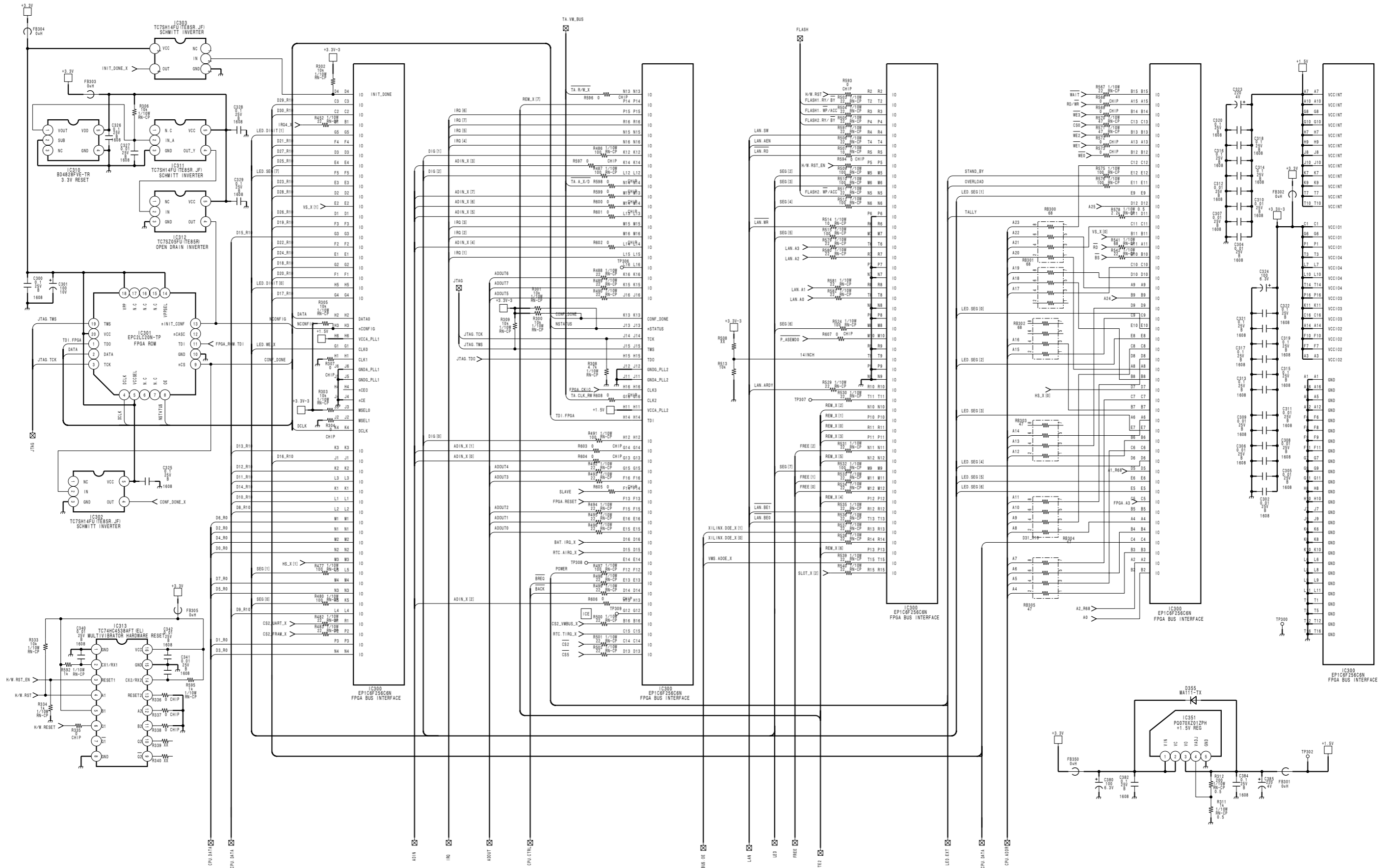

1

2

3

4

5

BC (7/7) BC (7/7)

1

2

3

4

5

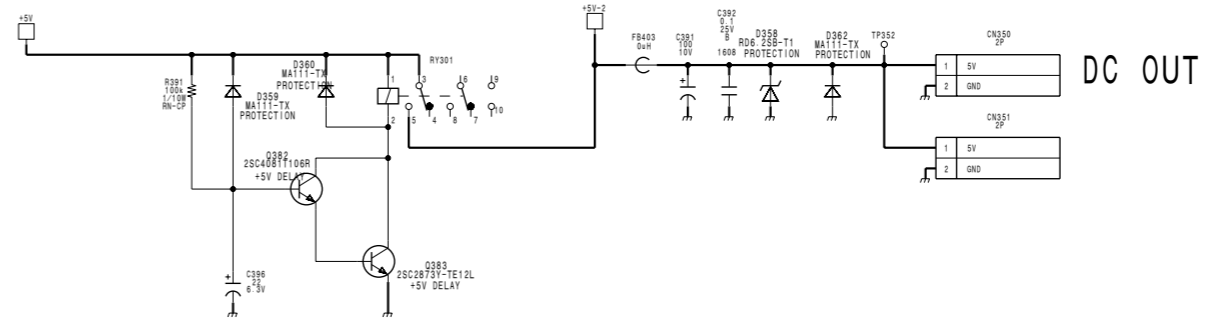
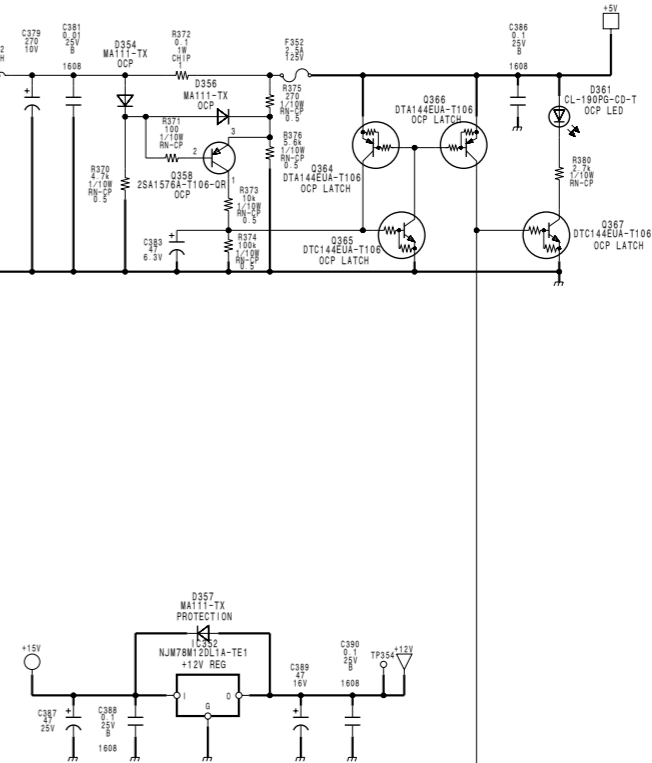
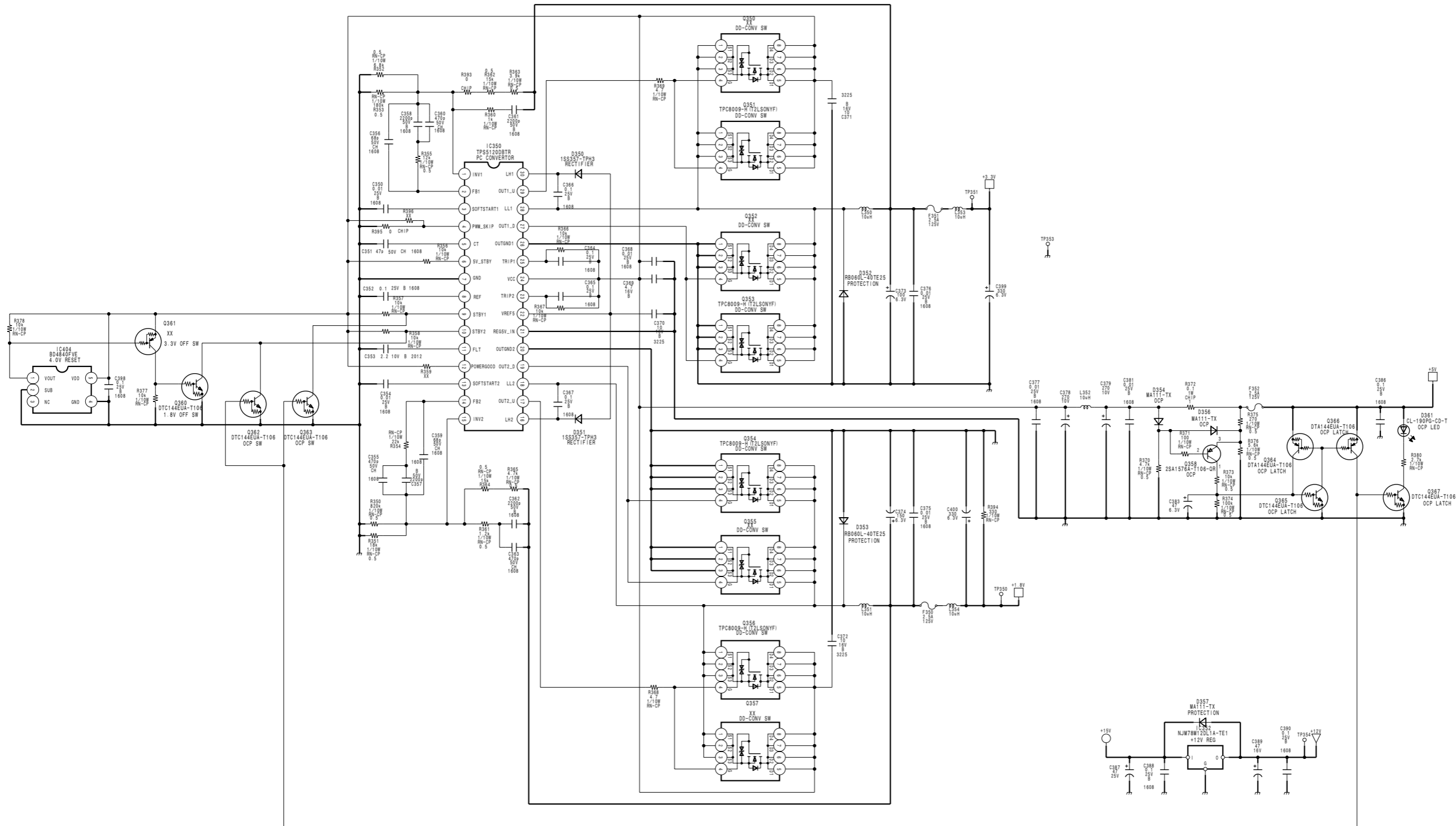

Mount Mecha	A001	259535301
Mount Mecha	A002	259535301

8-10

8-10

BVM-A14

A B C D E F G H

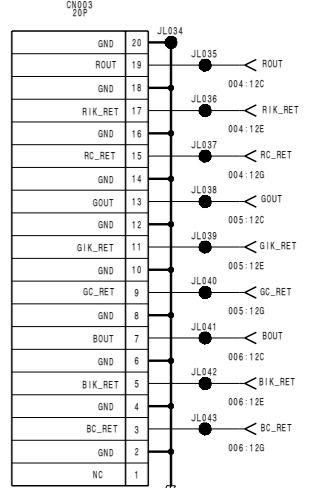
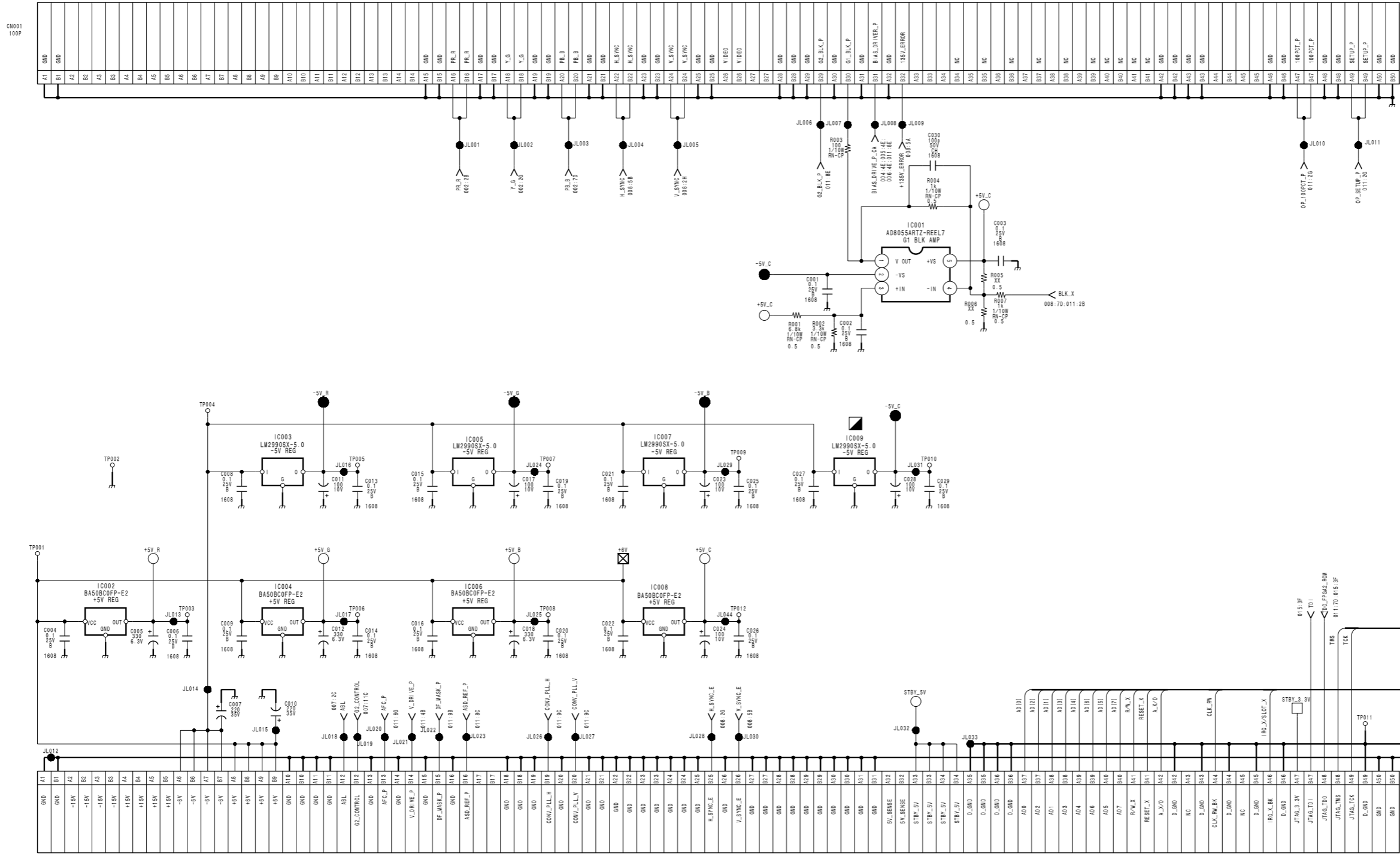

1

2

3

4

5

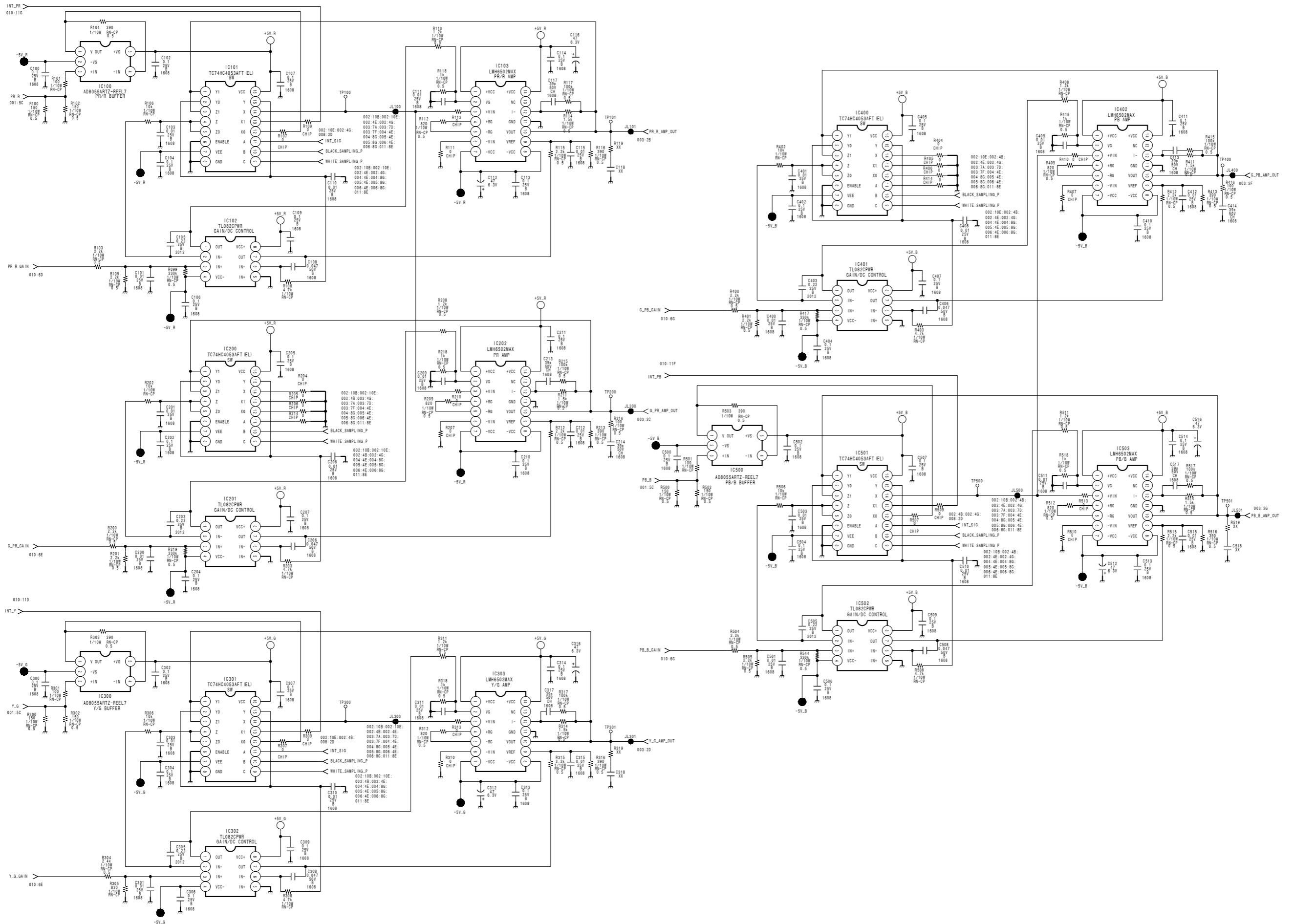

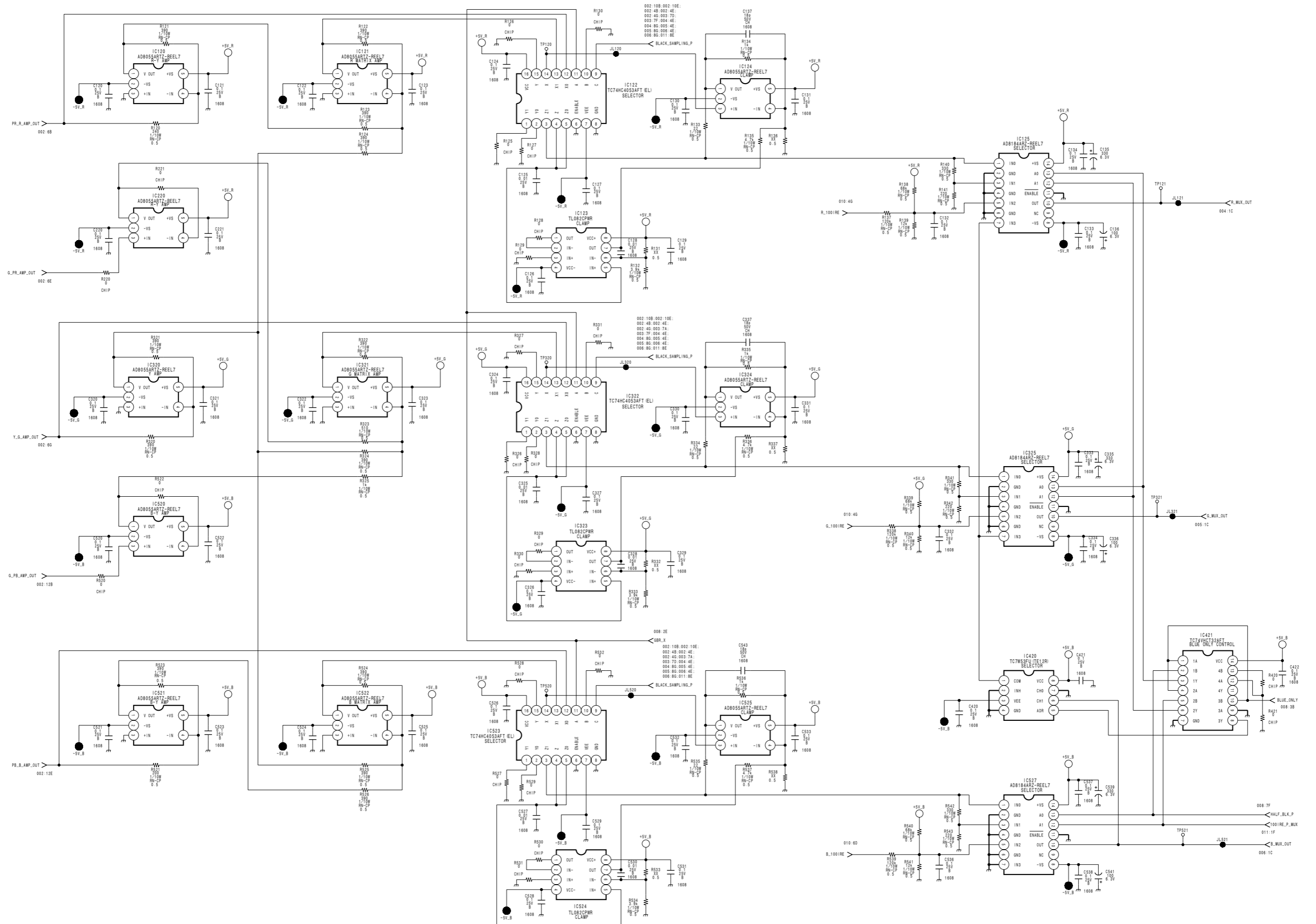

1

2

3

4

5

1

2

3

4

5

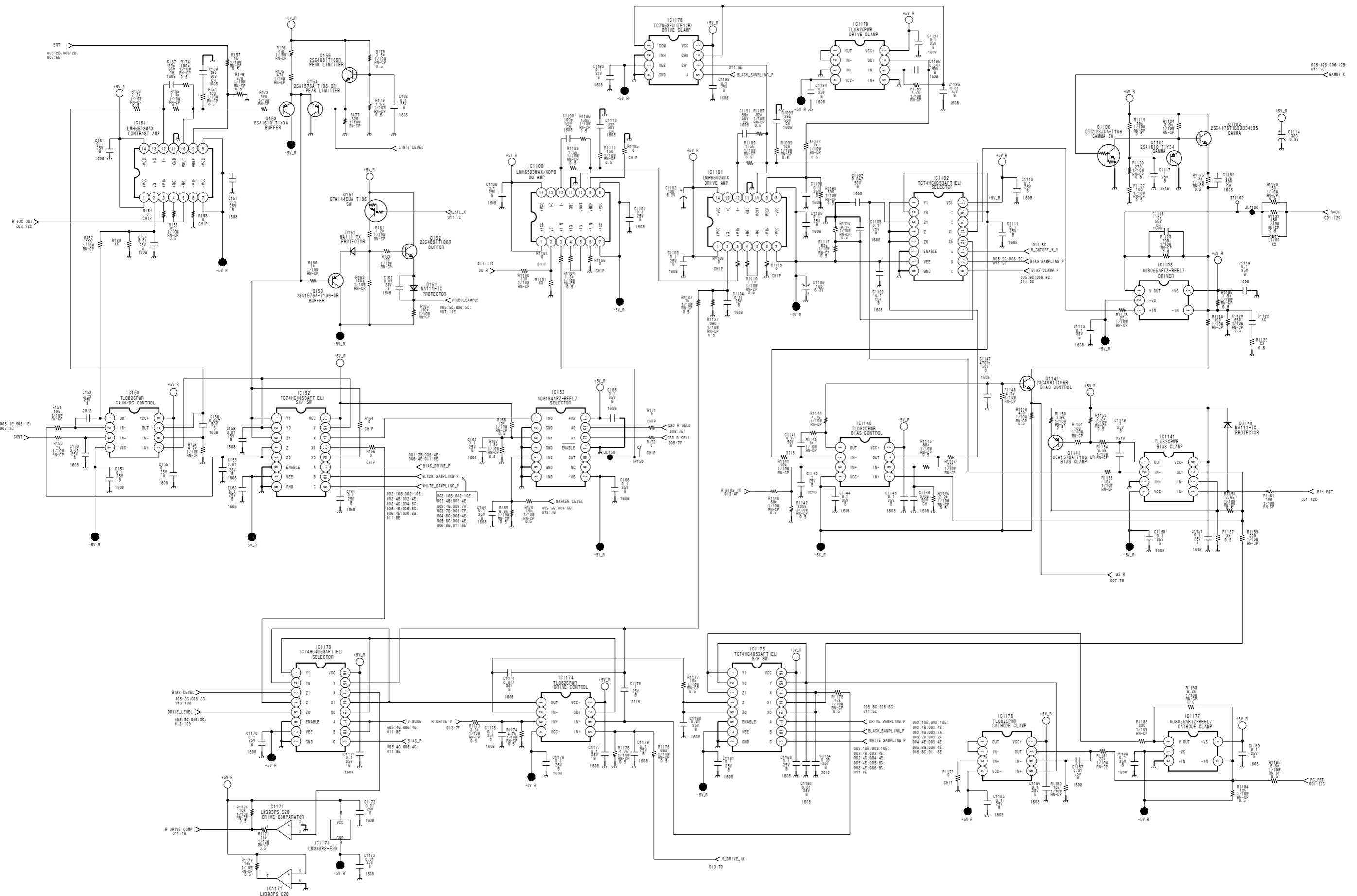

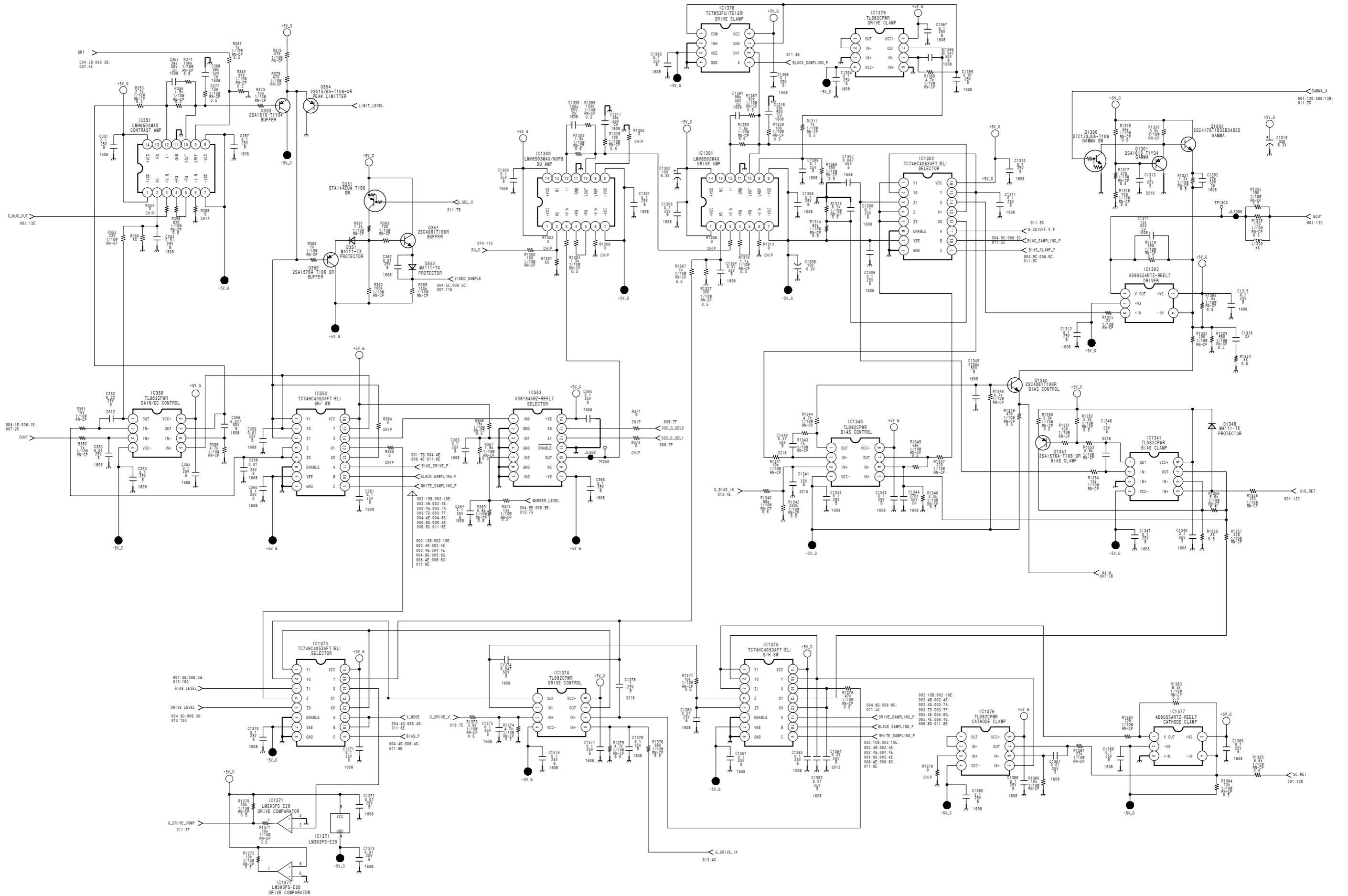

1

2

3

4

5

1

2

3

4

5

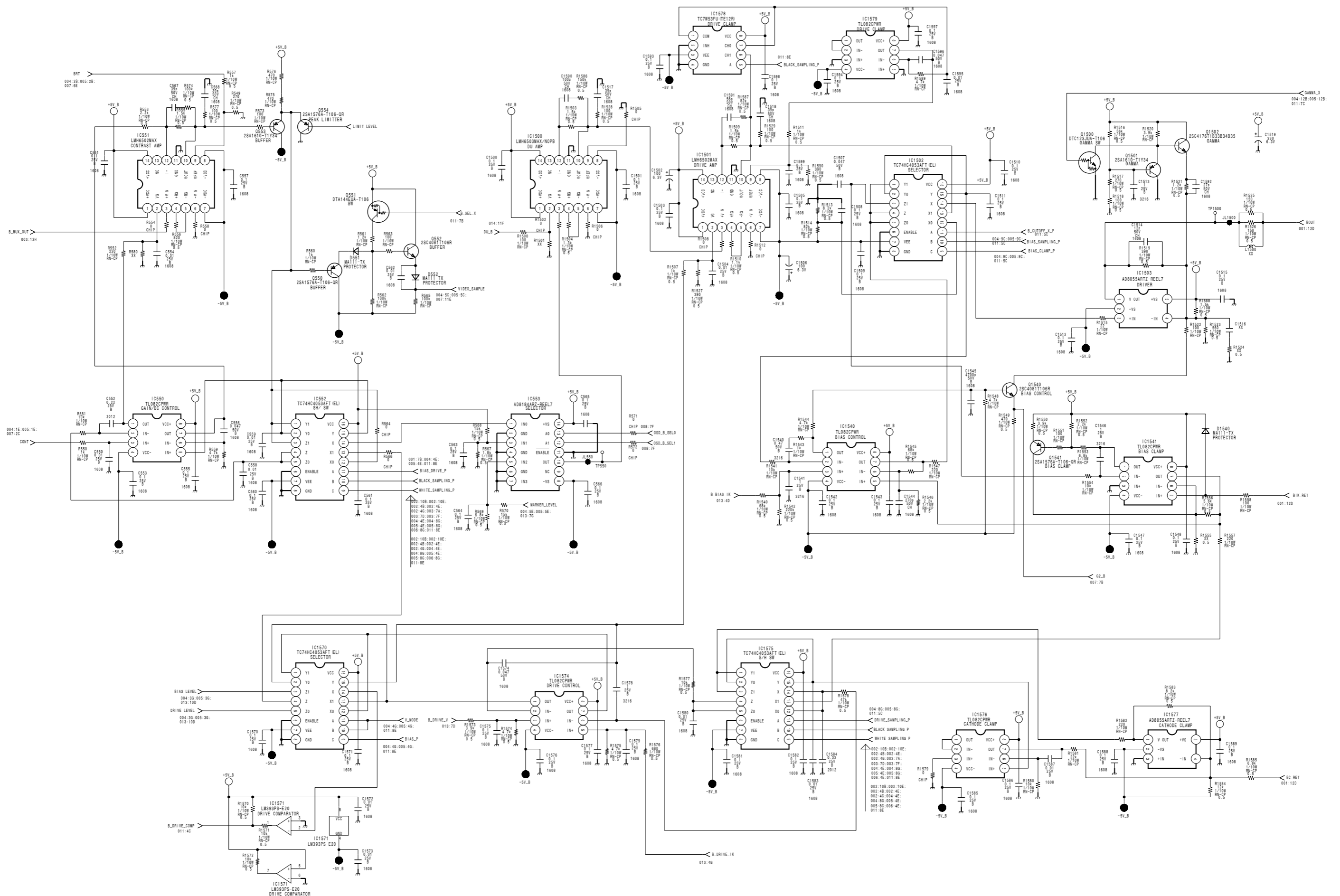

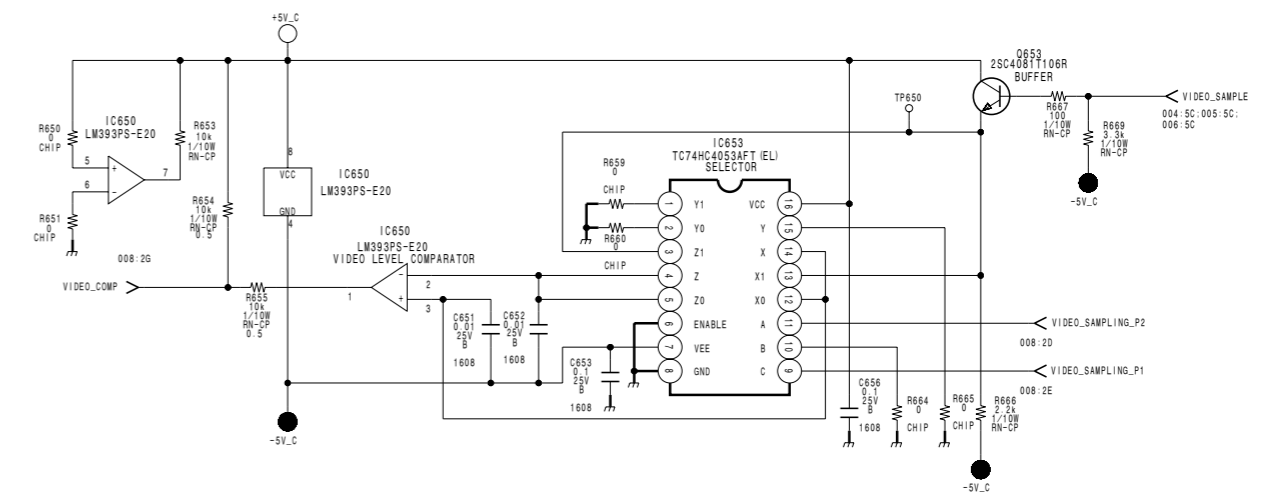
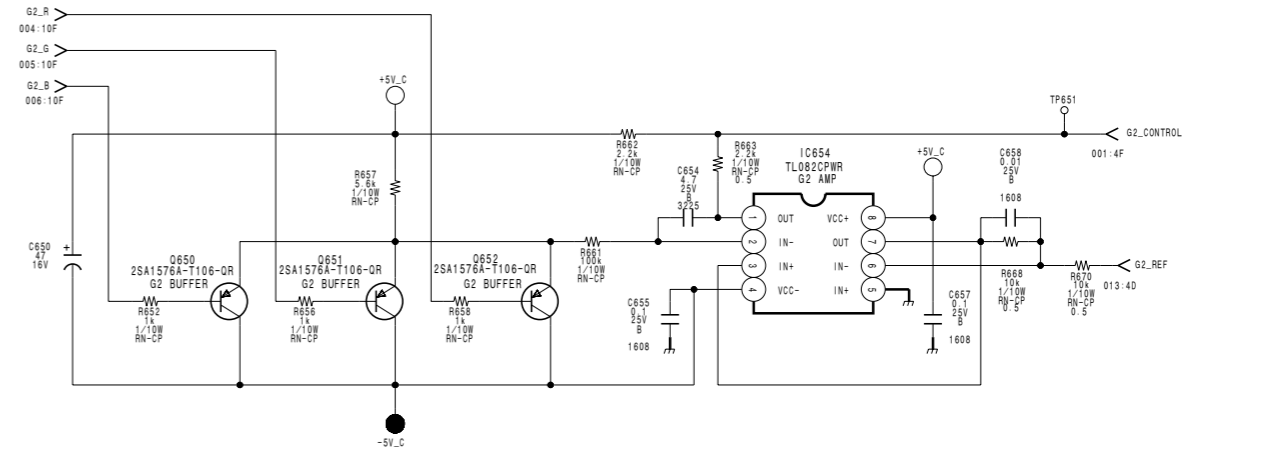
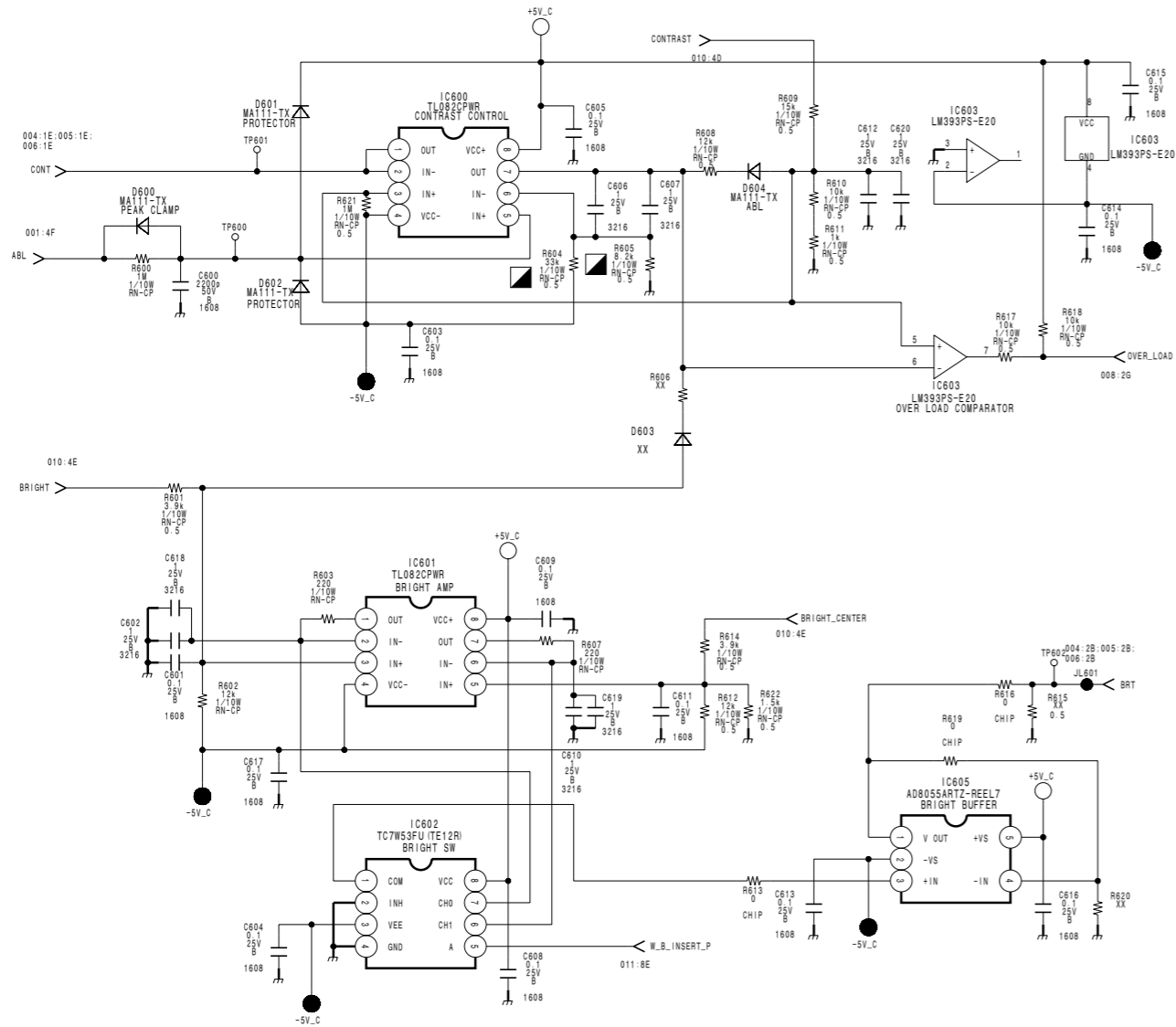

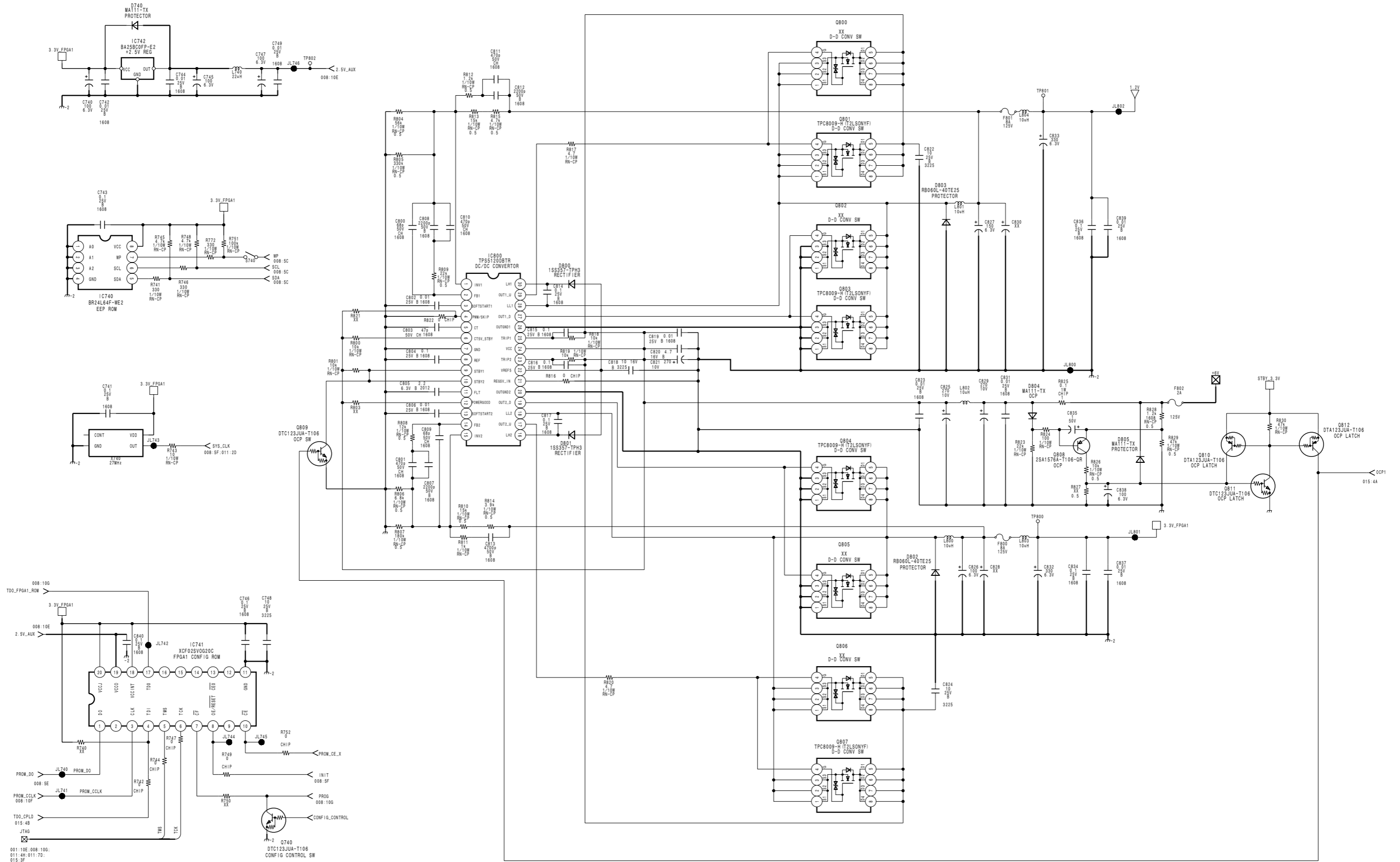

1

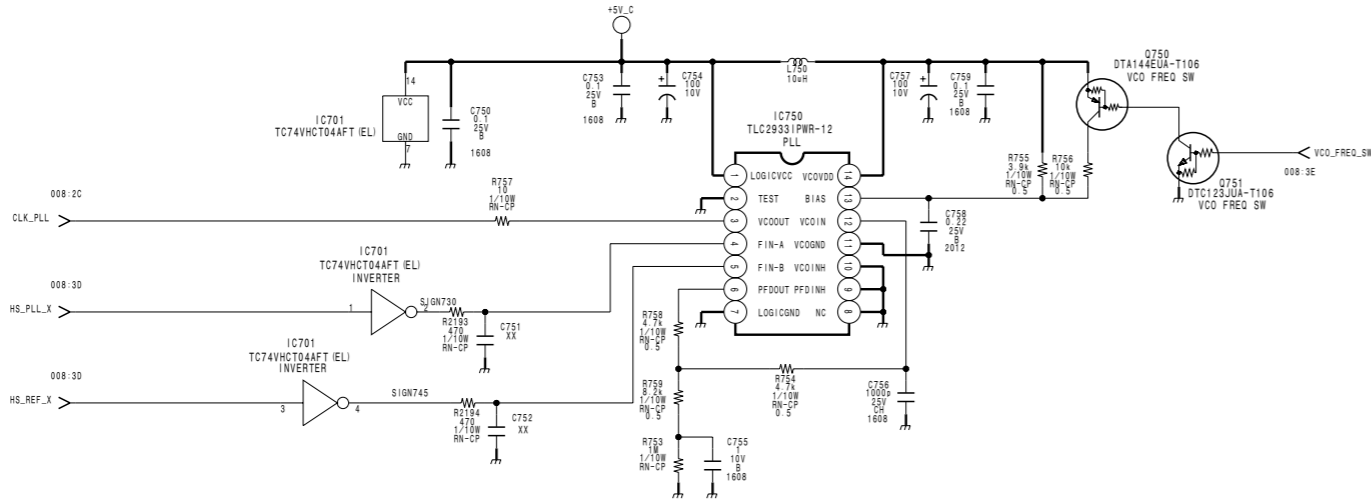

2

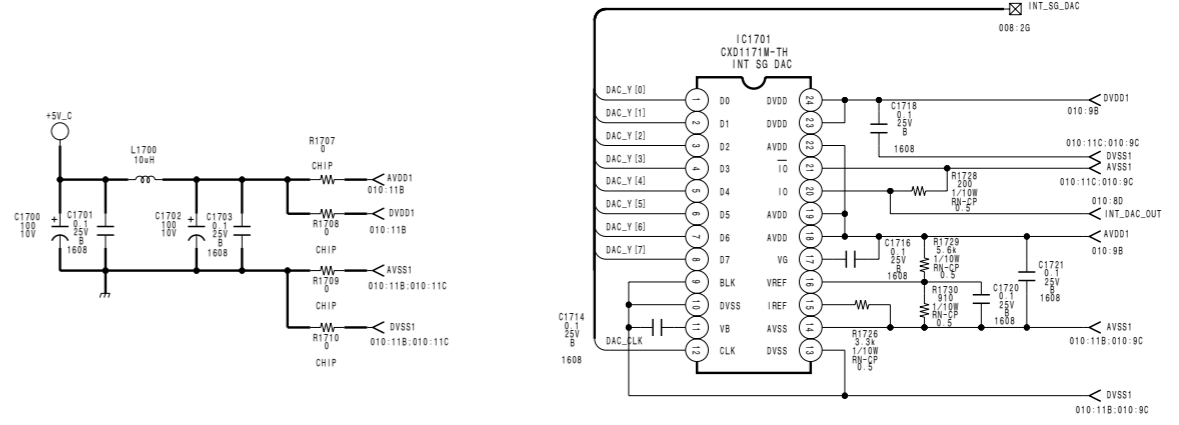

3

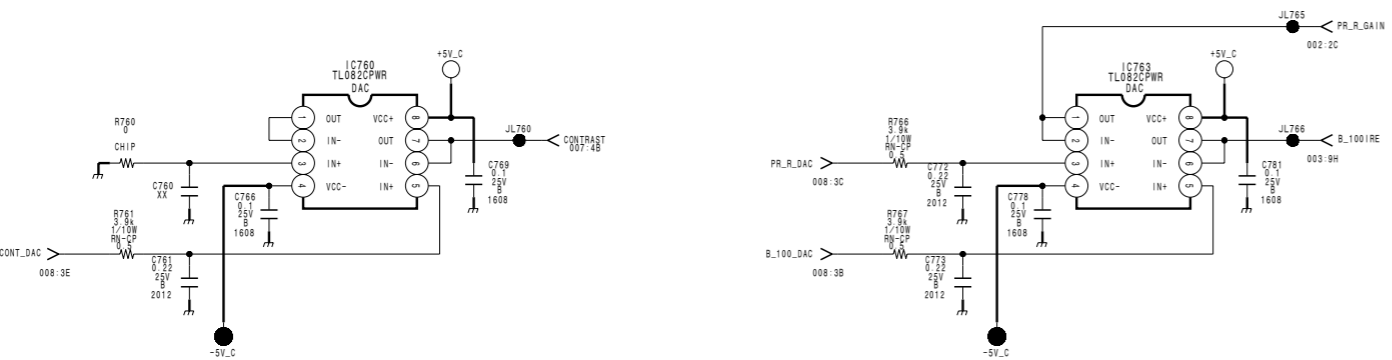

4

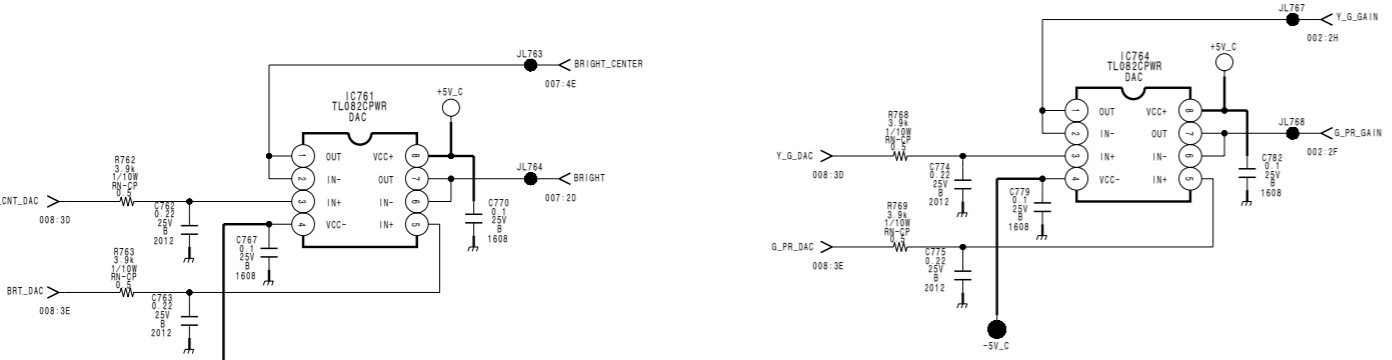

5

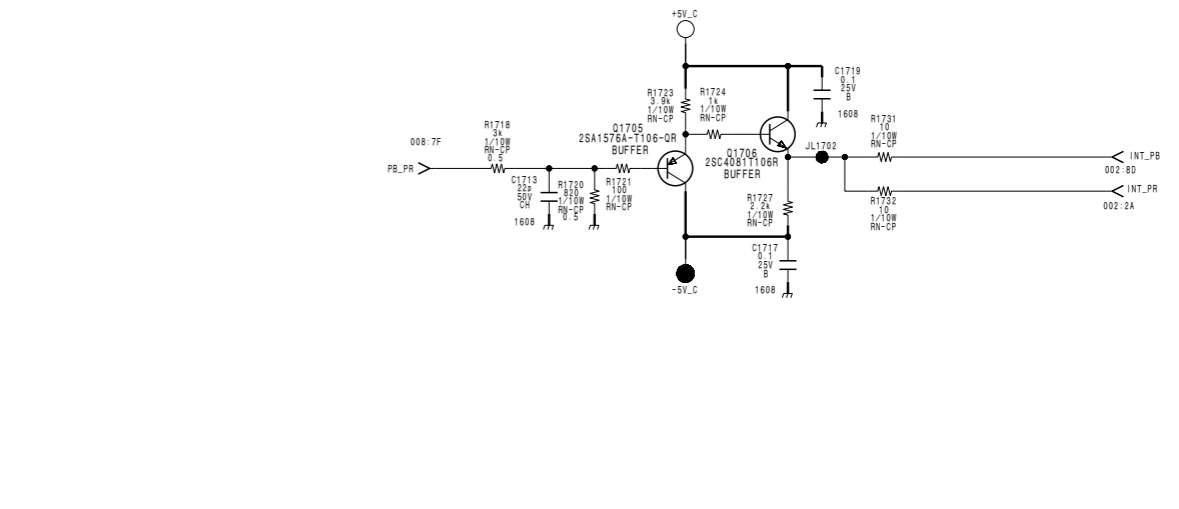
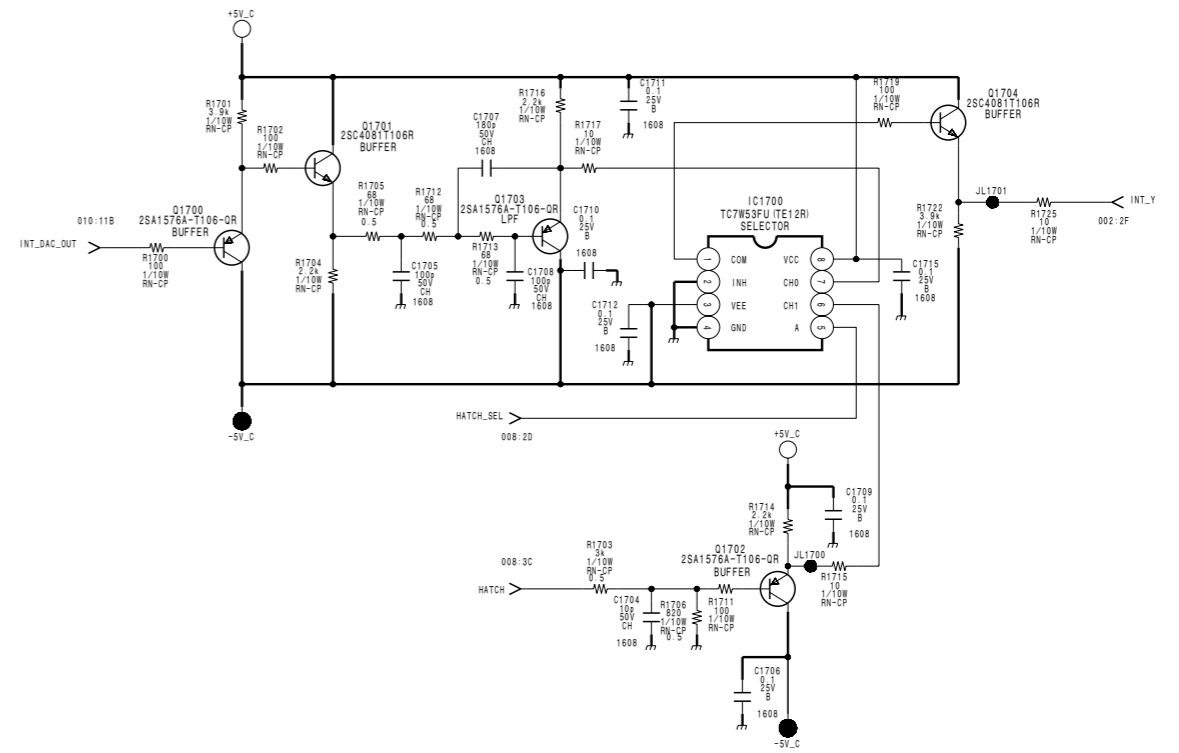
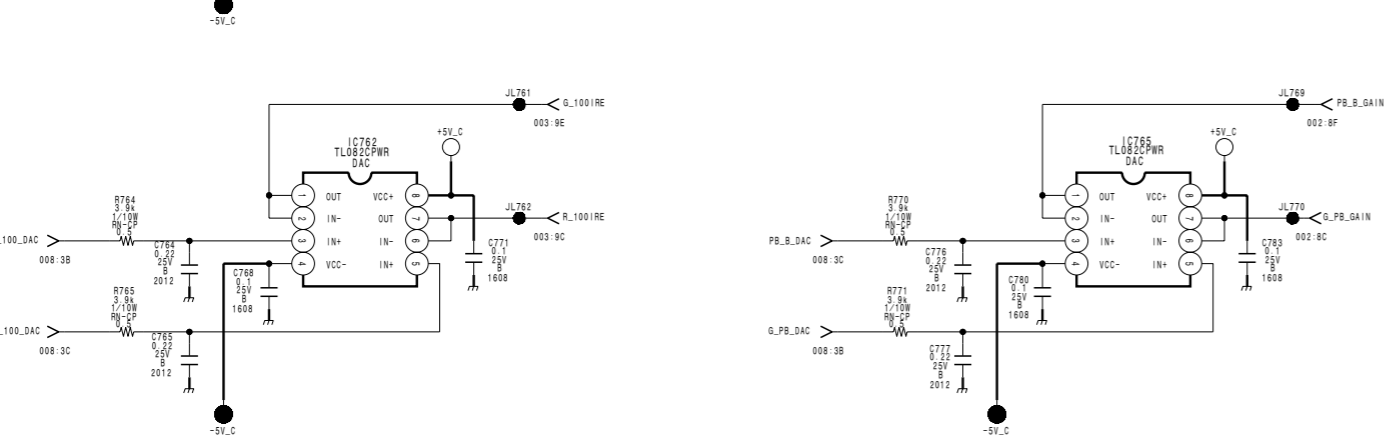

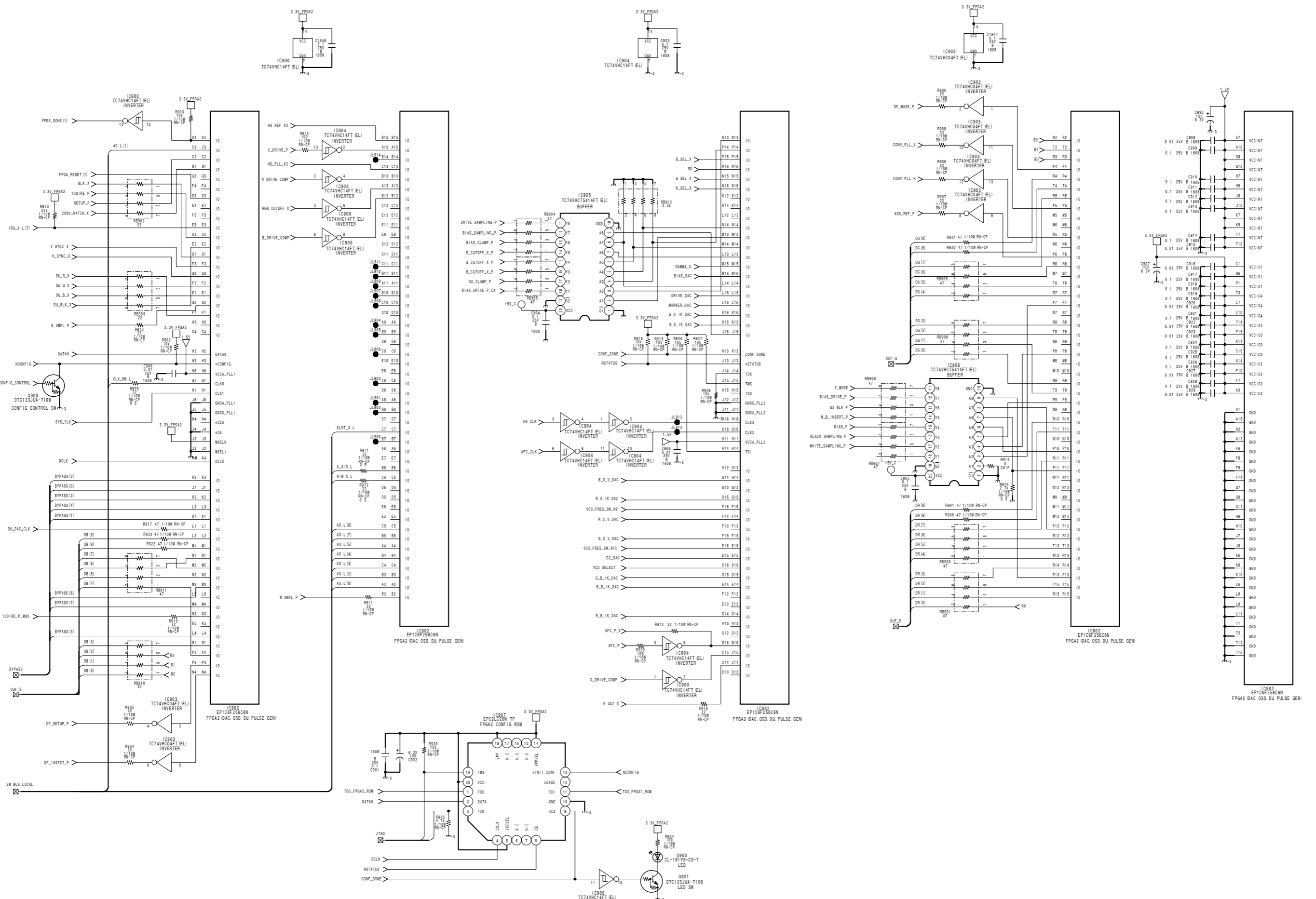

1

2

3

4

5

1

2

3

4

5

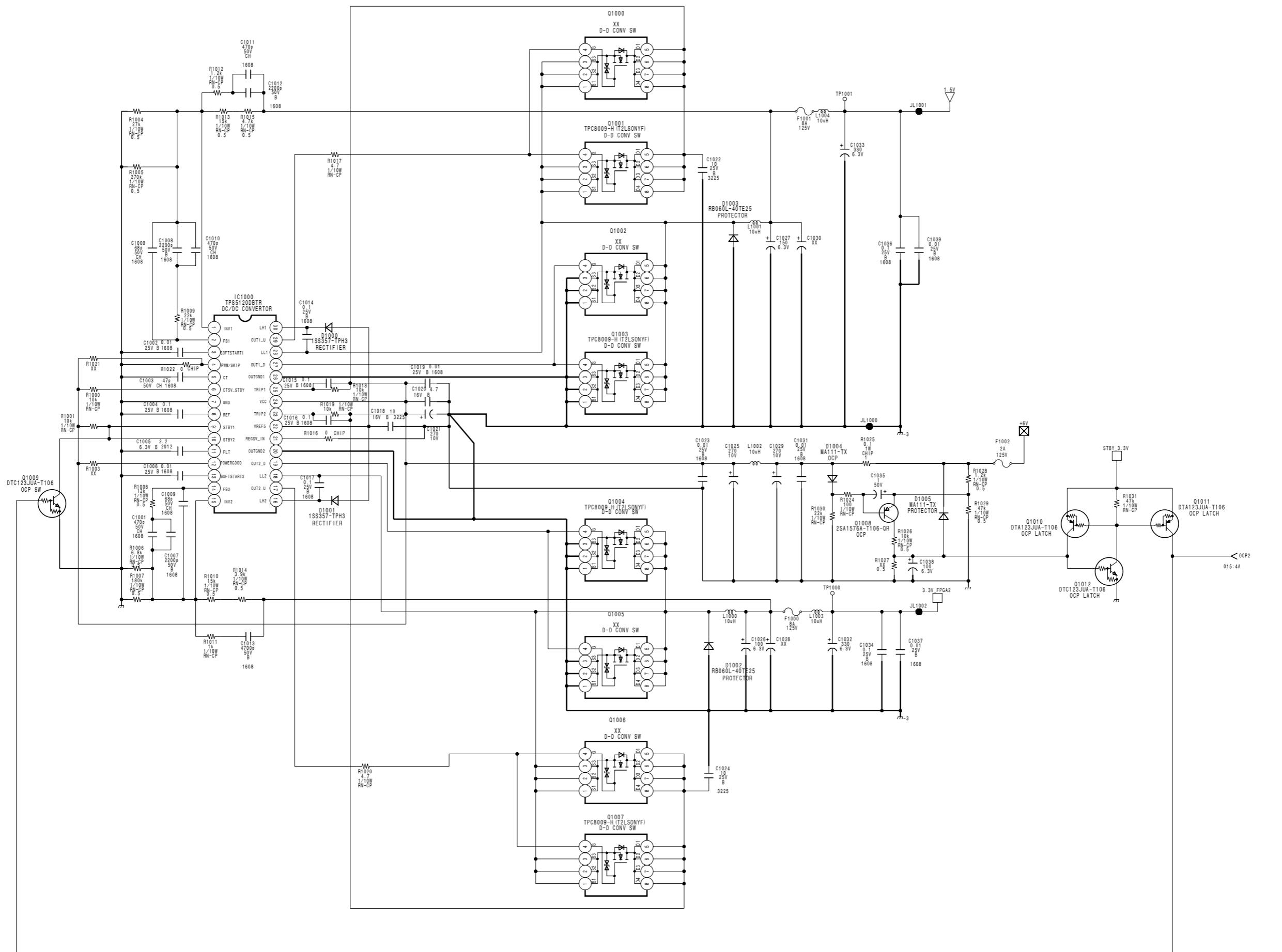

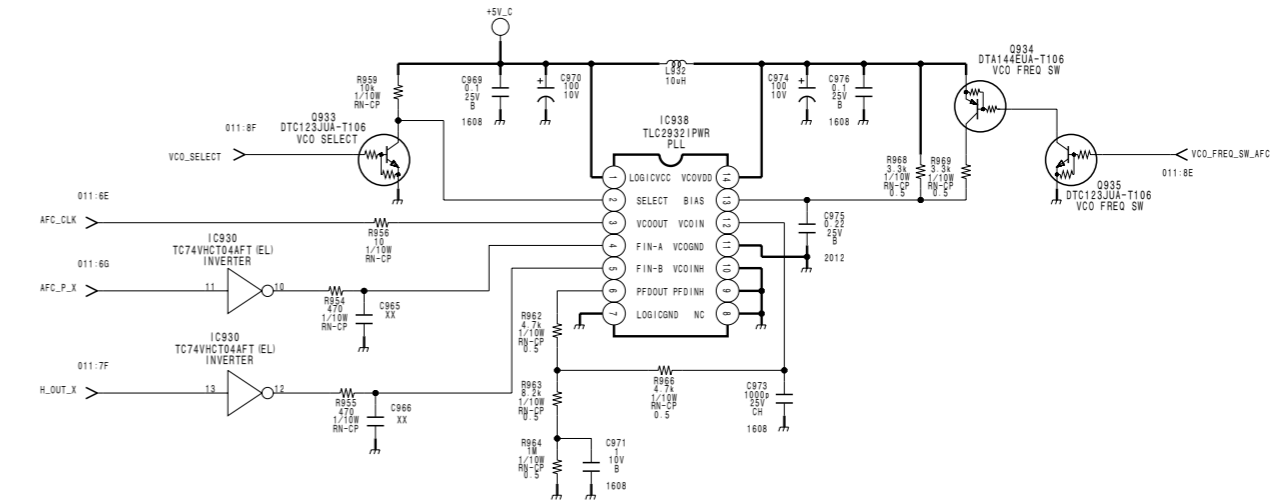
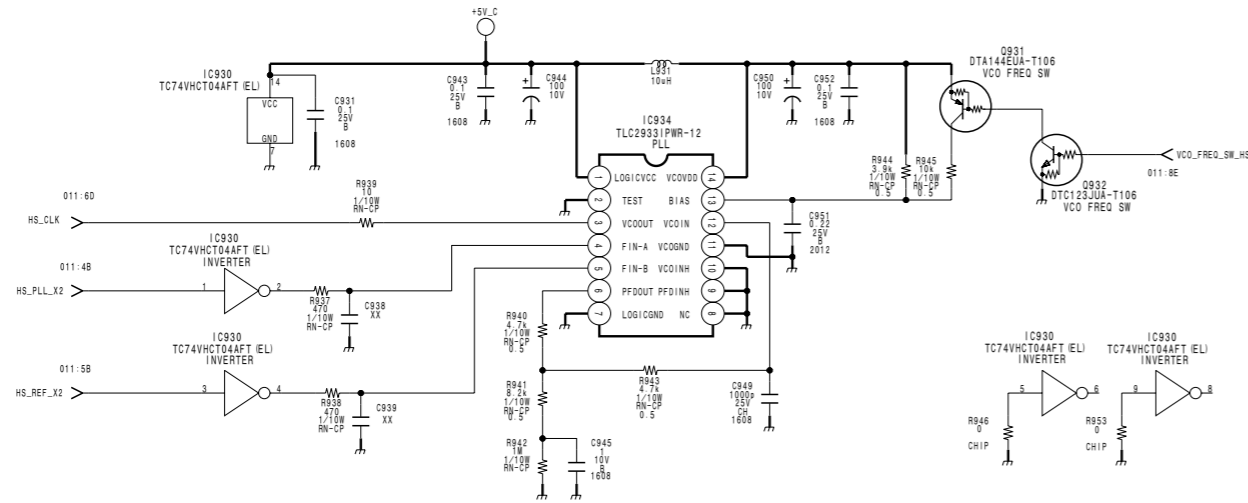

1

2

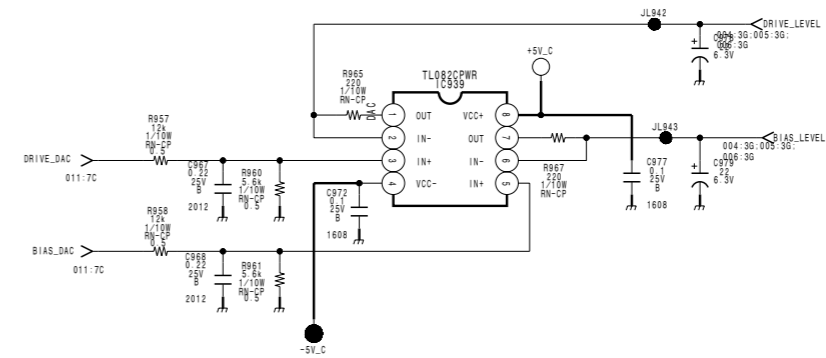
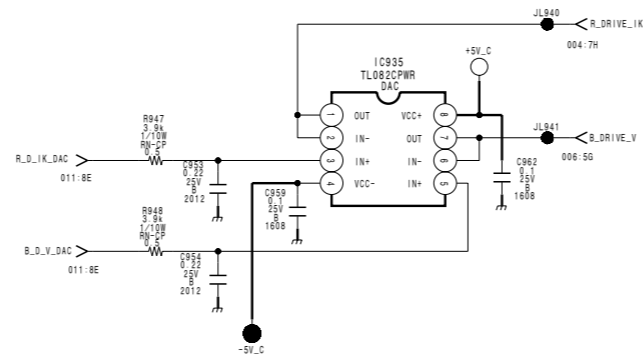
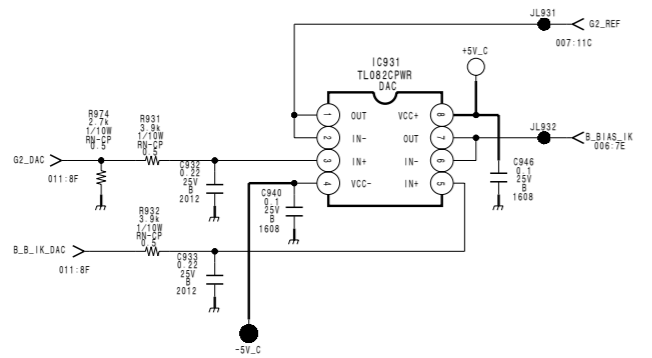

3

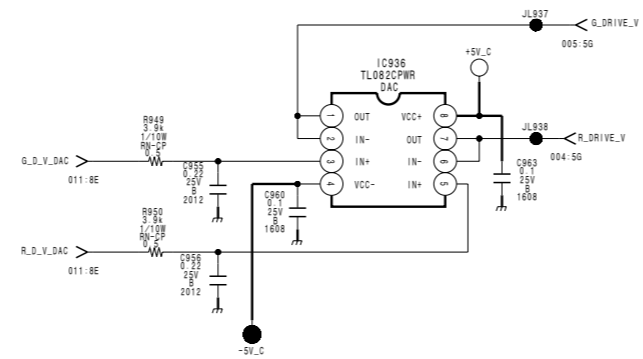
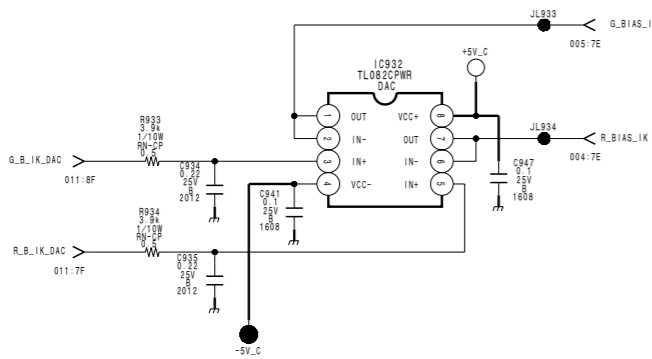

4

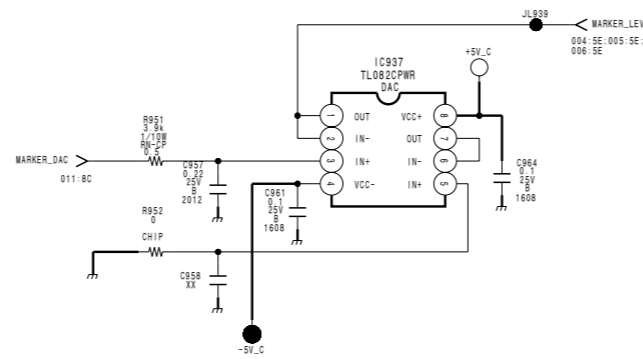
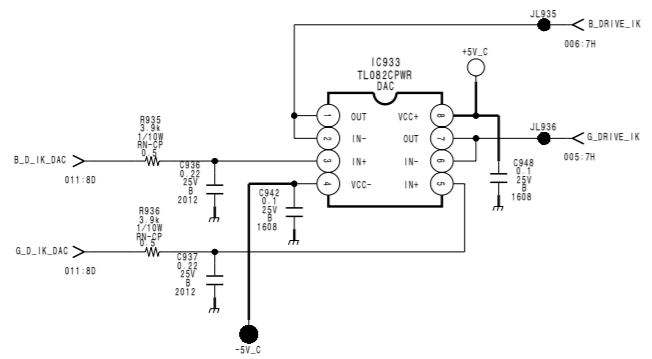

5

1

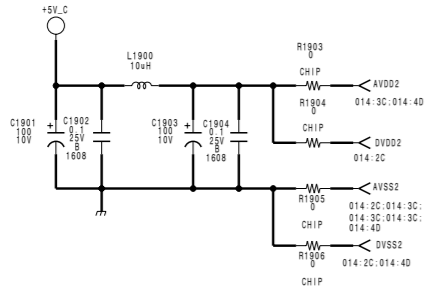

2

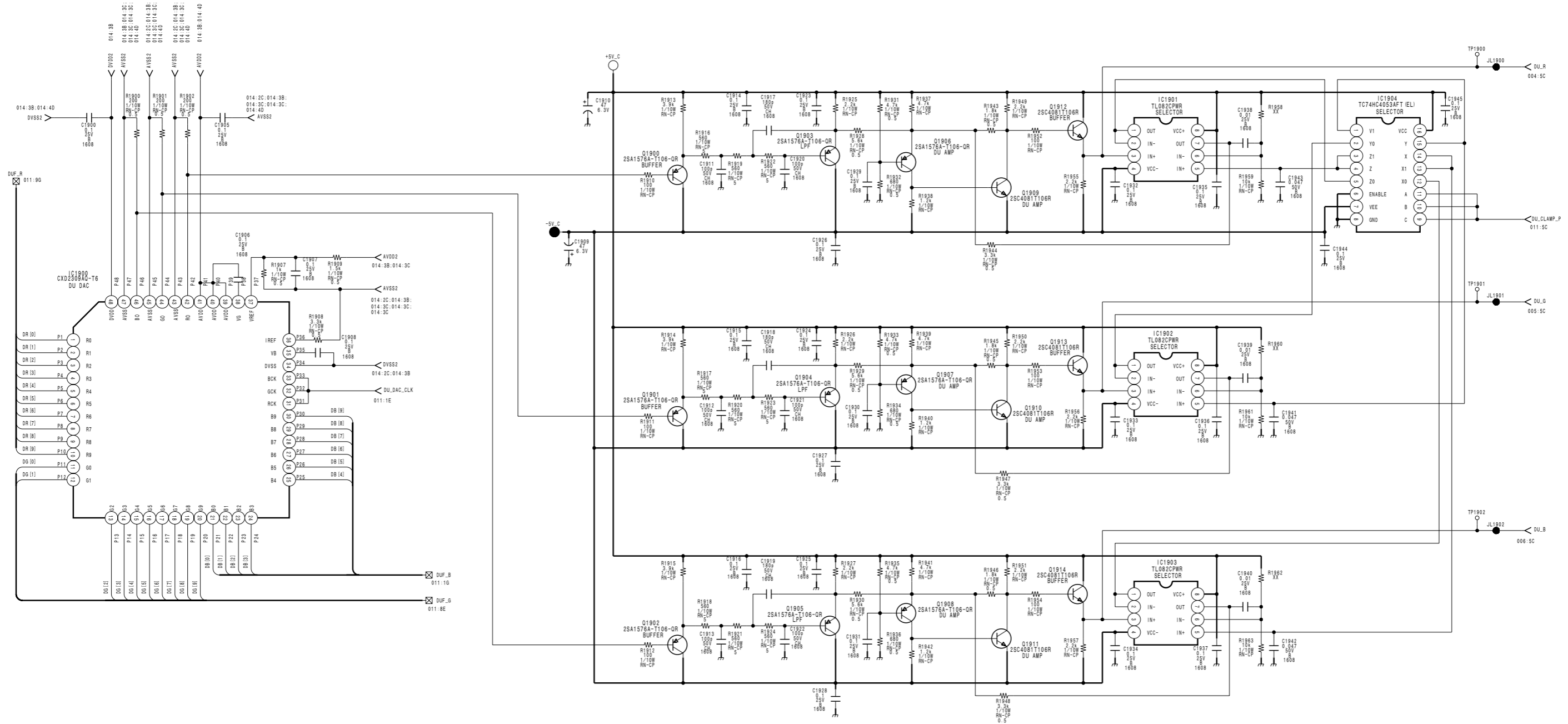

3

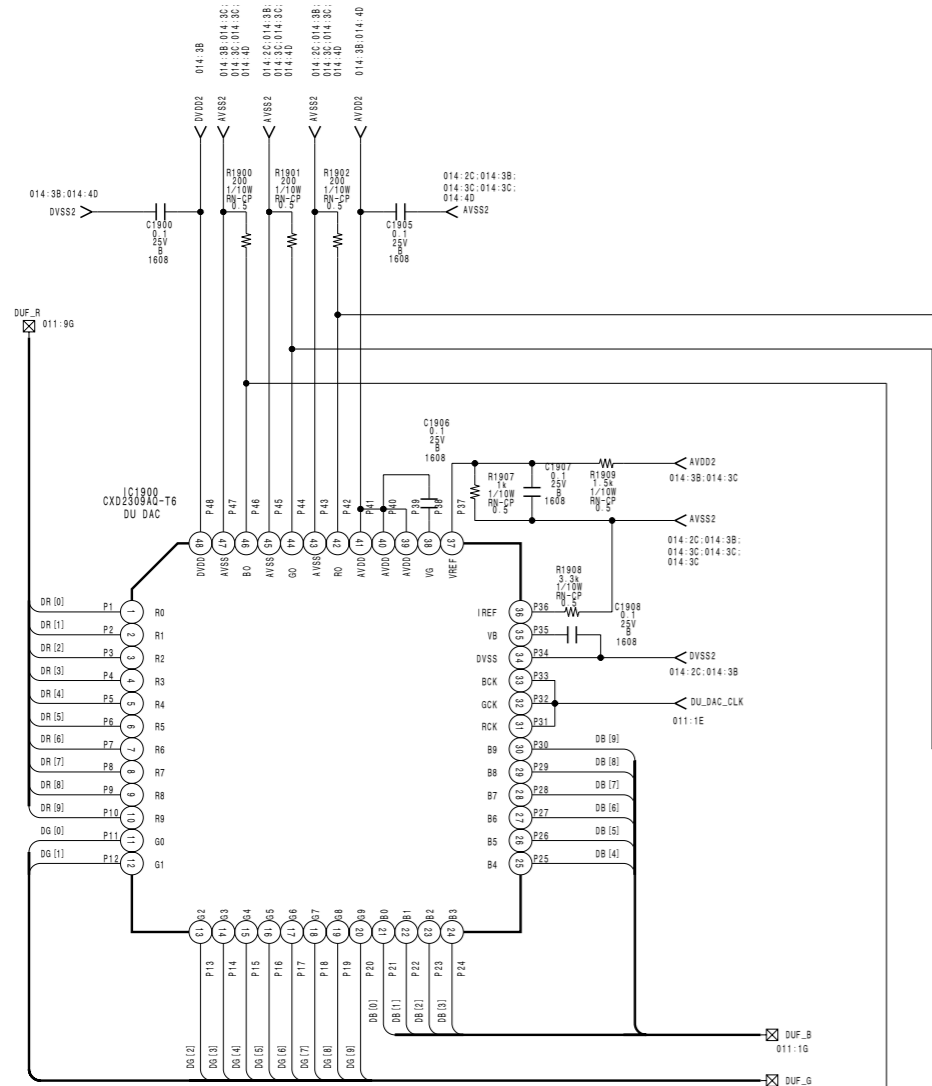

4

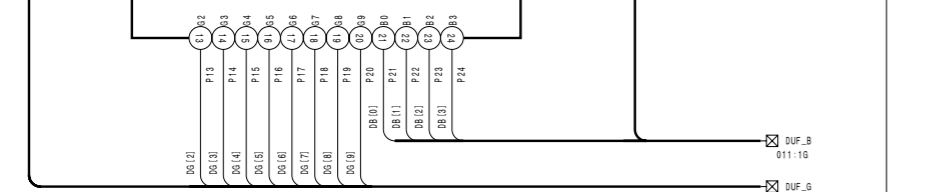

5



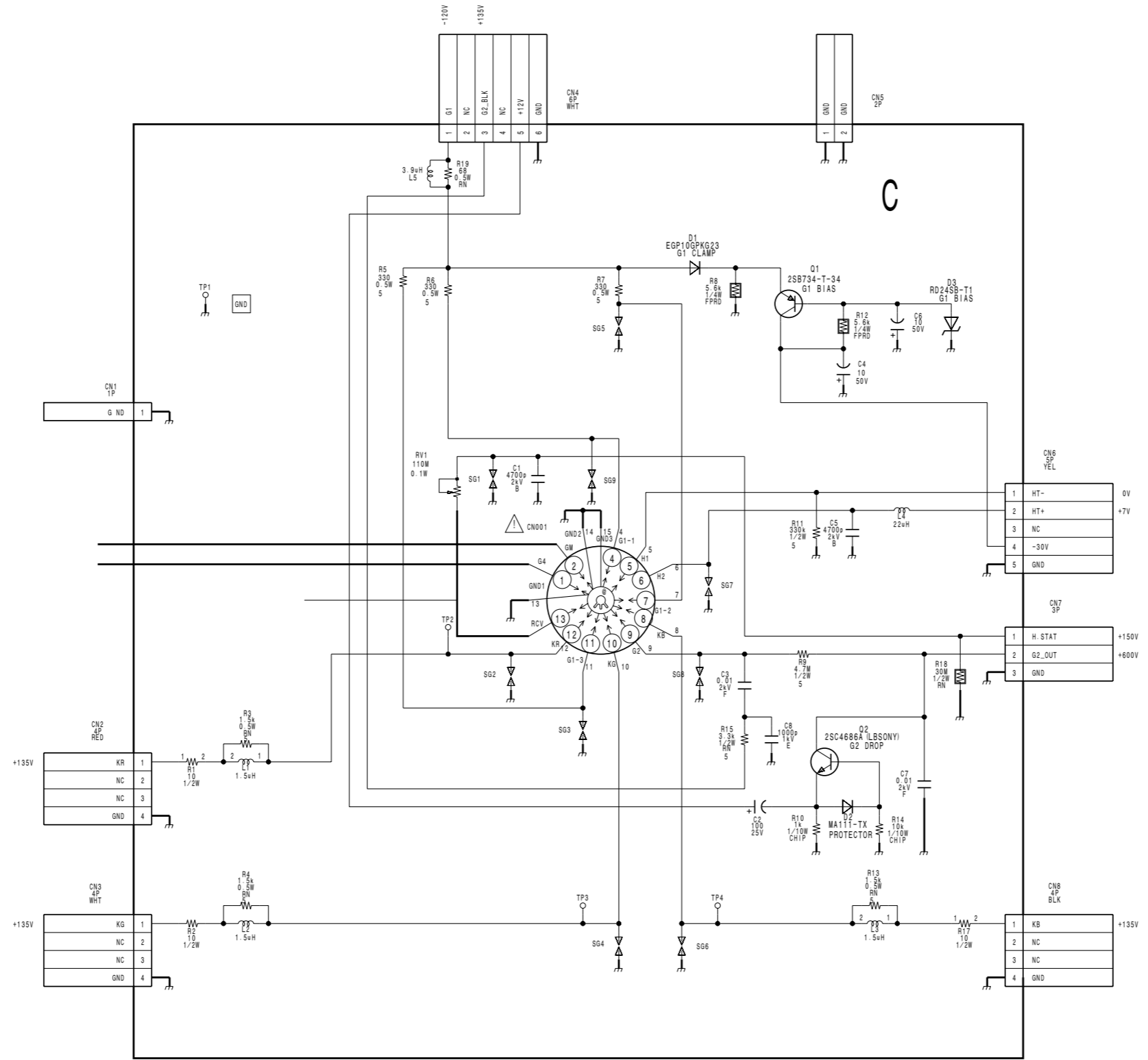

1

2

3

4

5

A

B

C

D

E

F

G

H

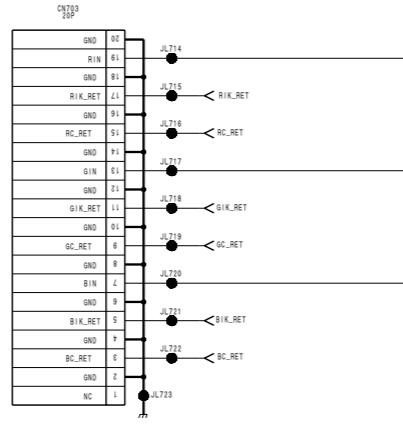
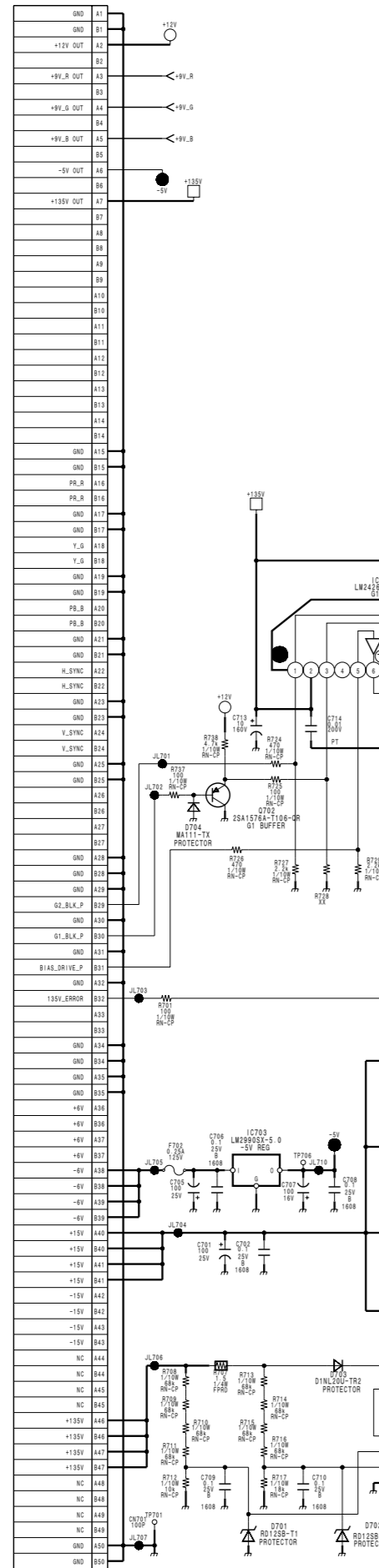
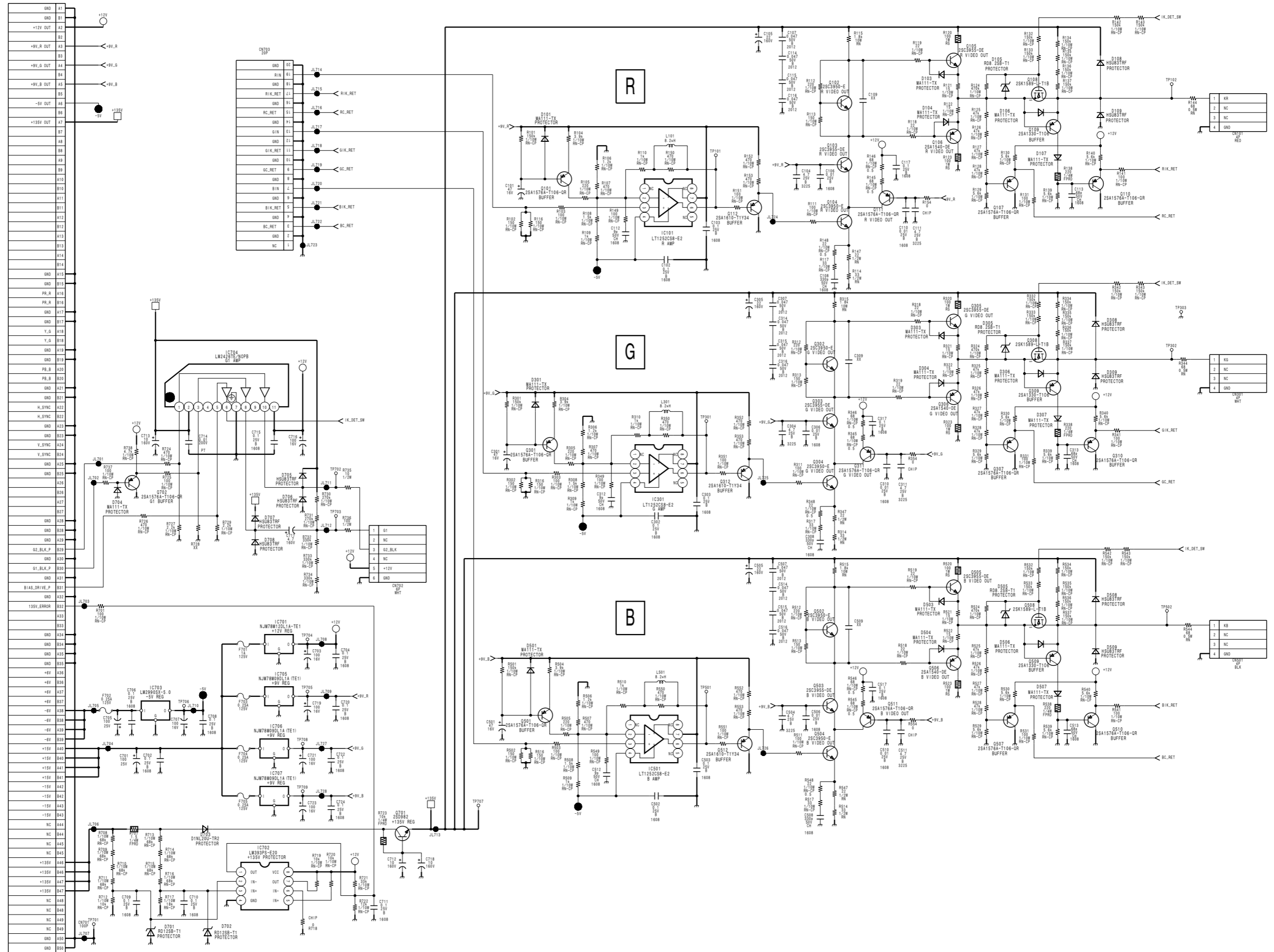

R

G

B

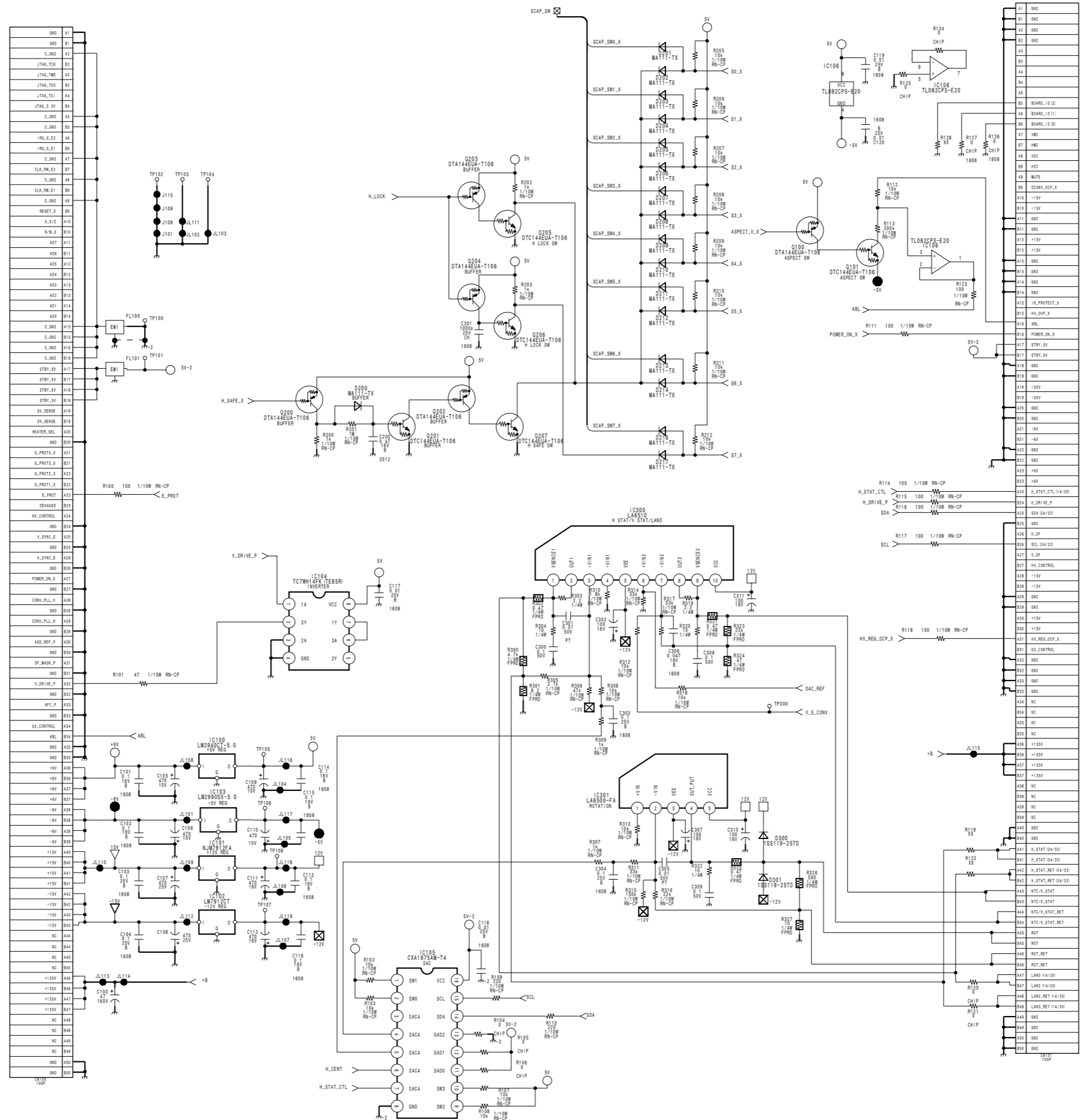

1

2

3

4

5

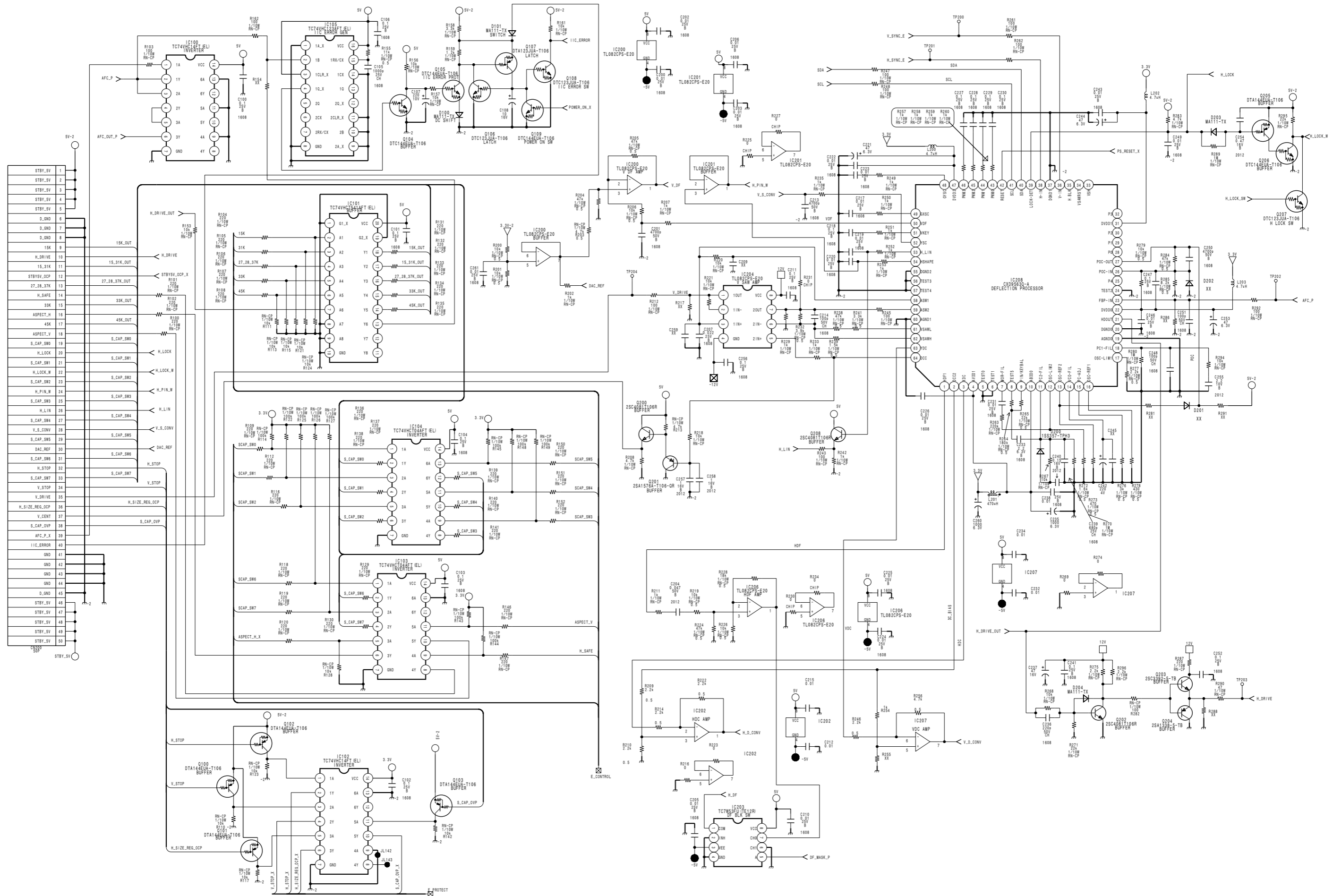

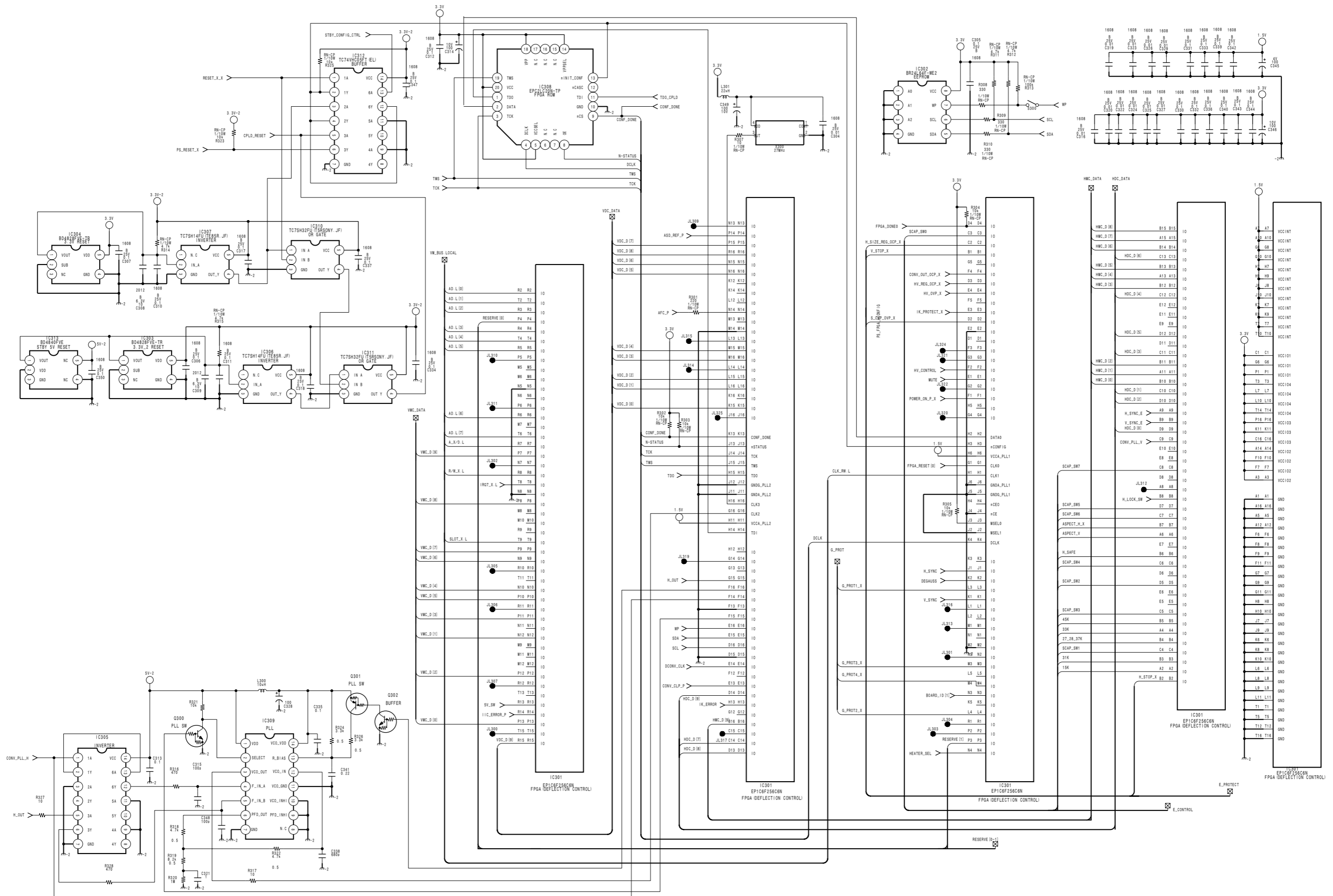

1

2

3

4

5

1

2

3

4

5

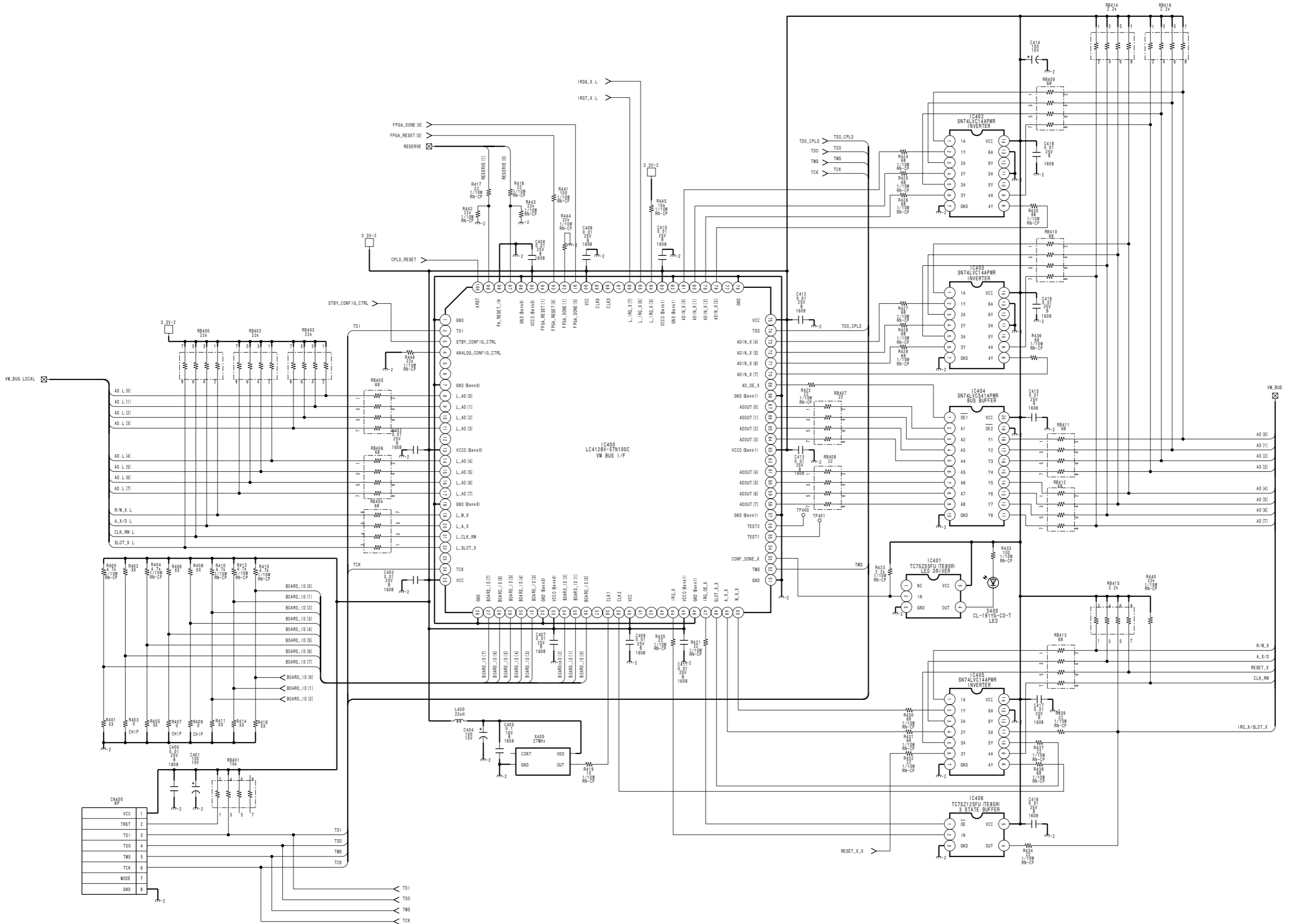

A B C D E F G H

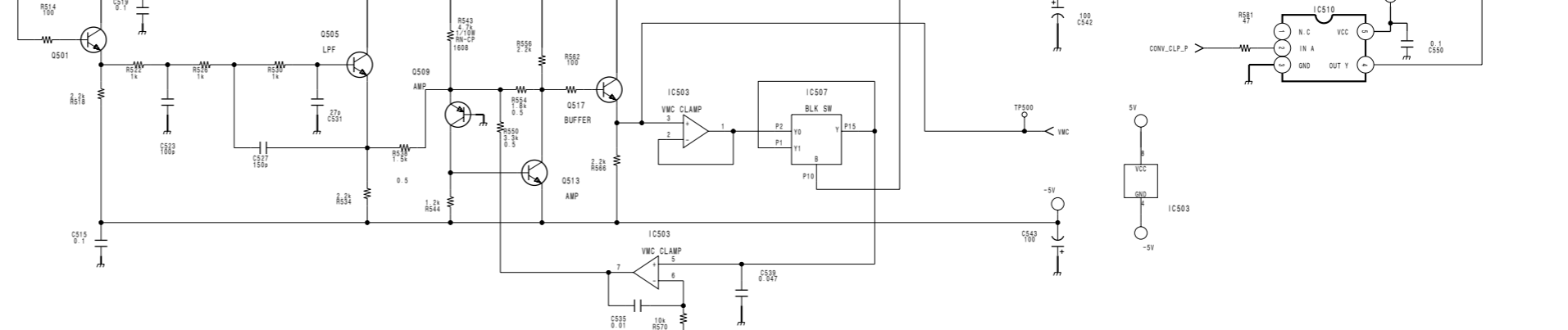
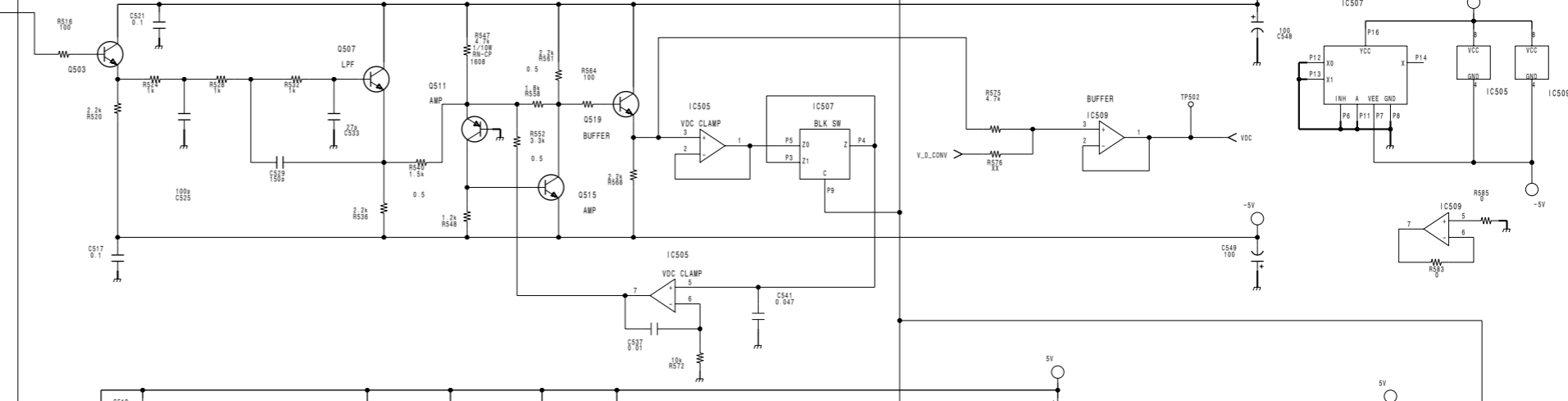
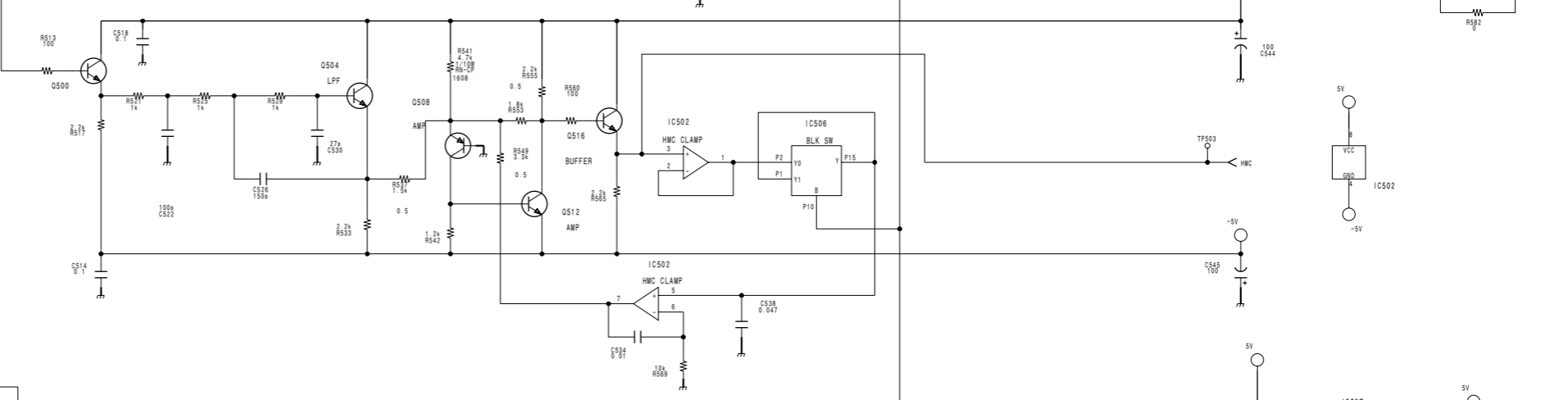
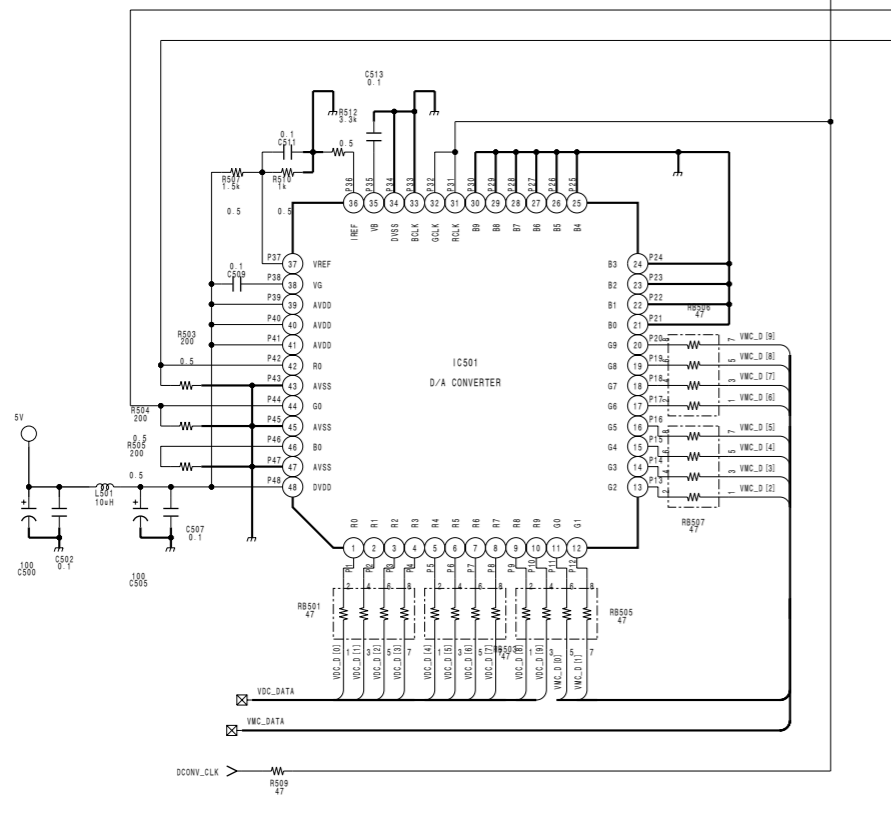
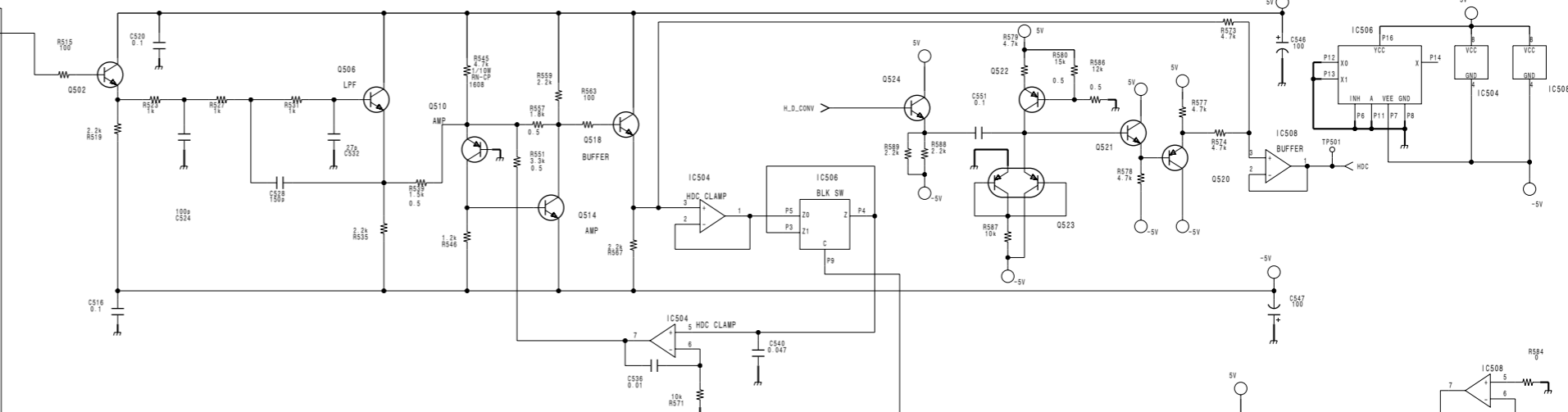
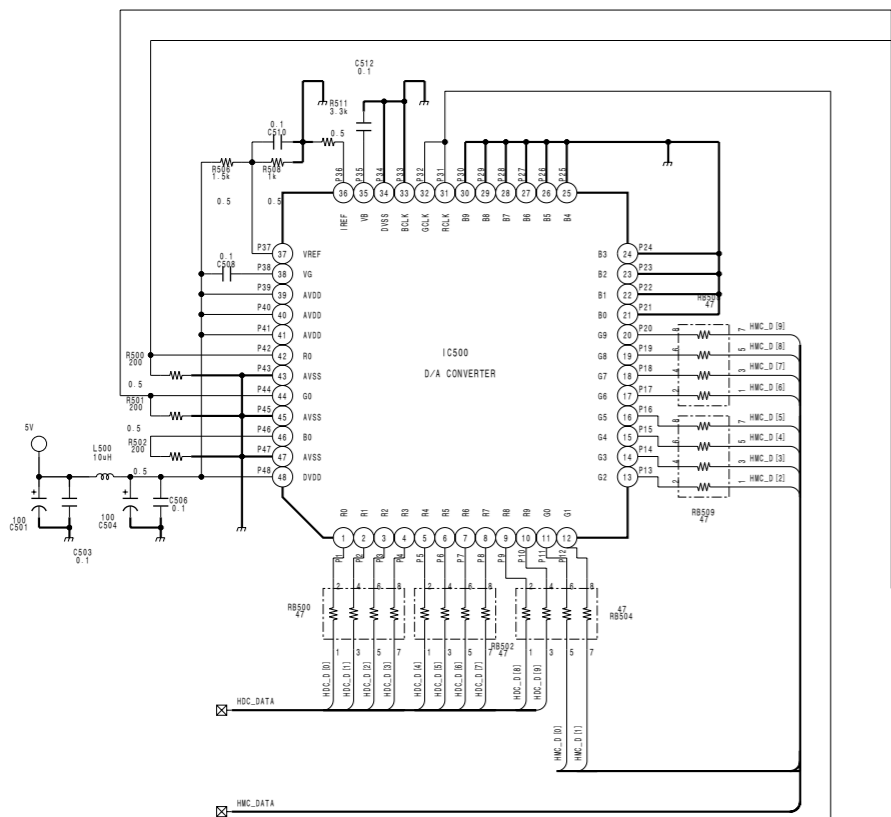

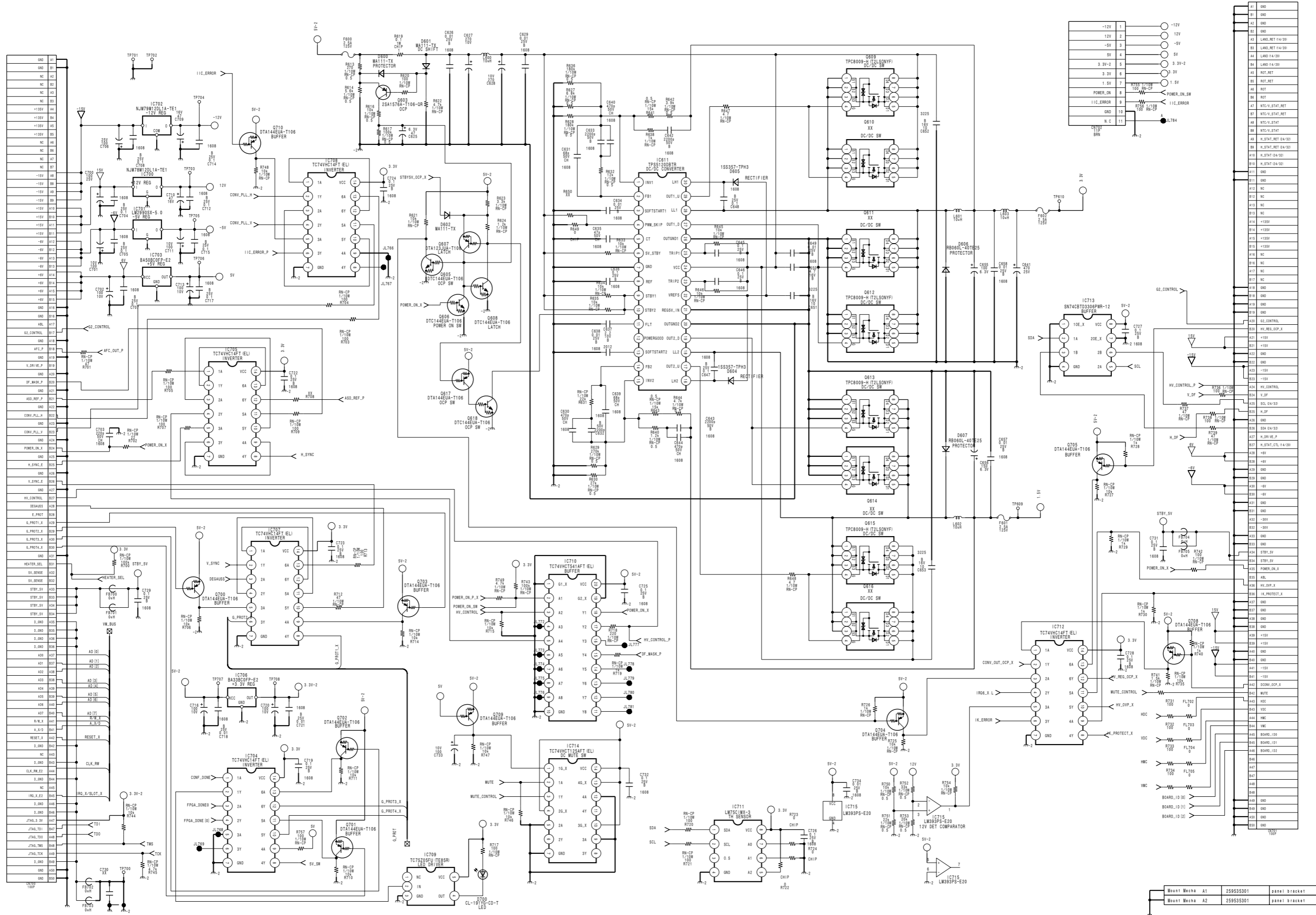

Mount Mecha A1	25953301	panel bracket
Mount Mecha A2	25953301	panel bracket

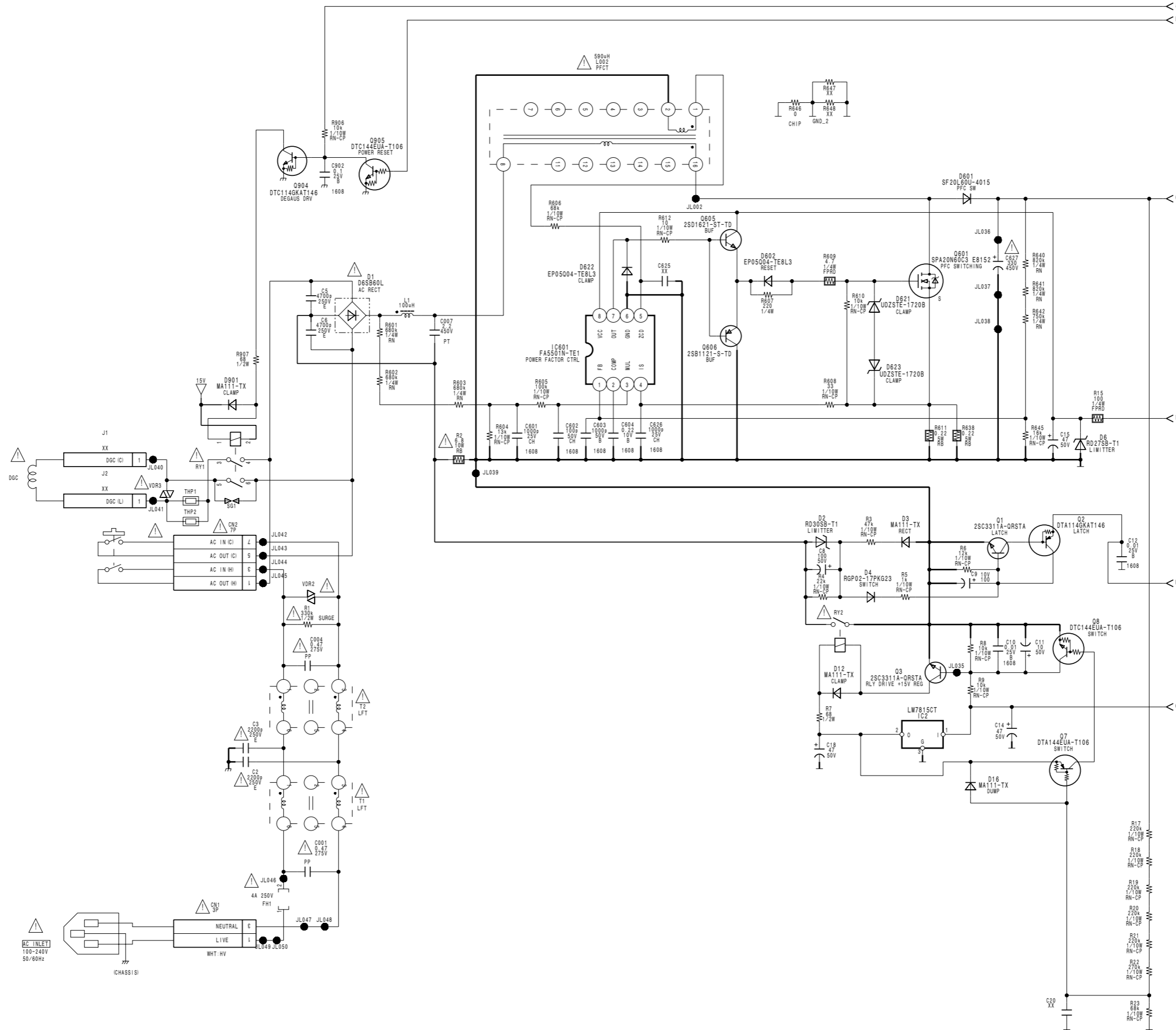

1

2

3

4

5

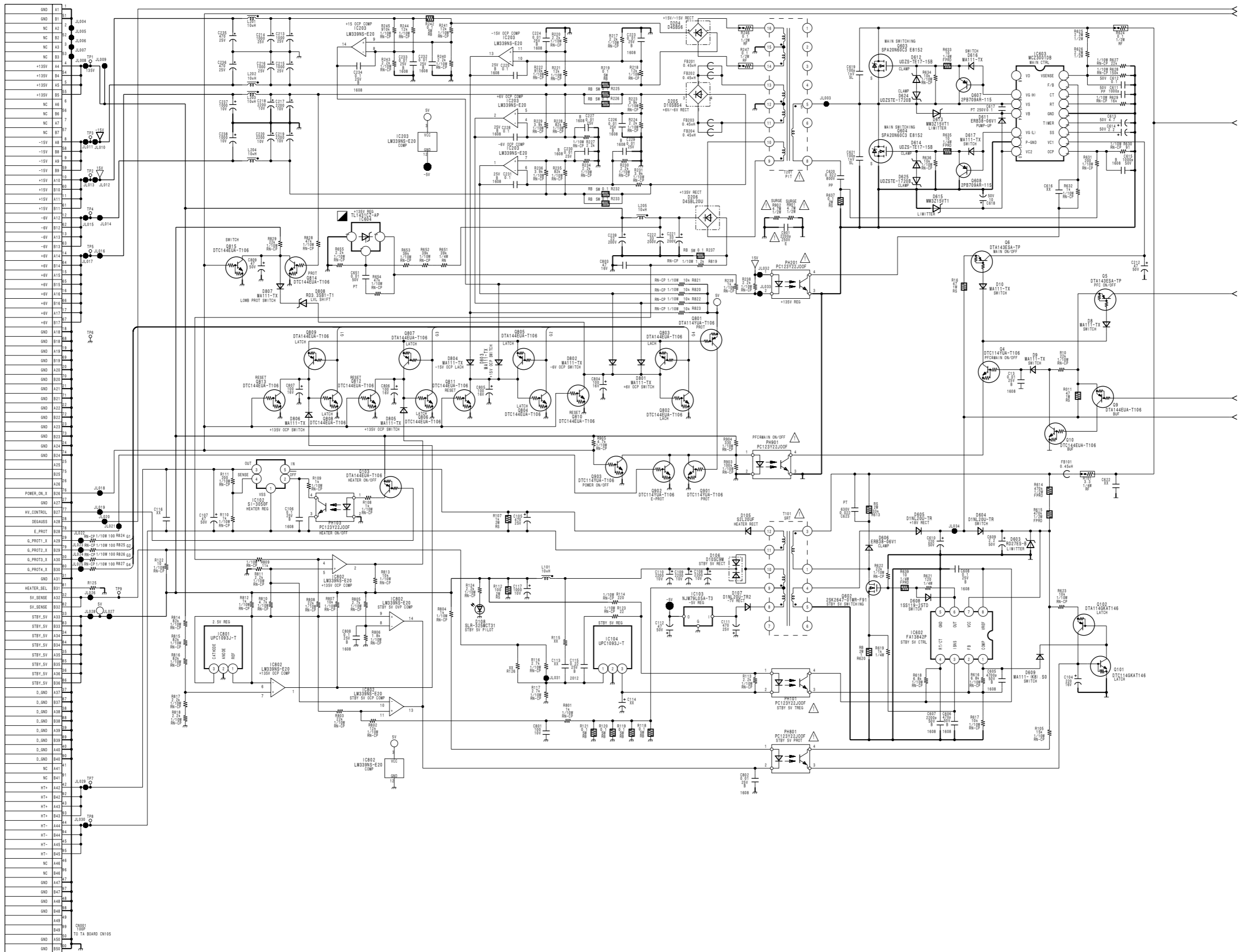

1

2

3

4

5

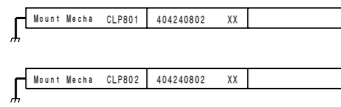
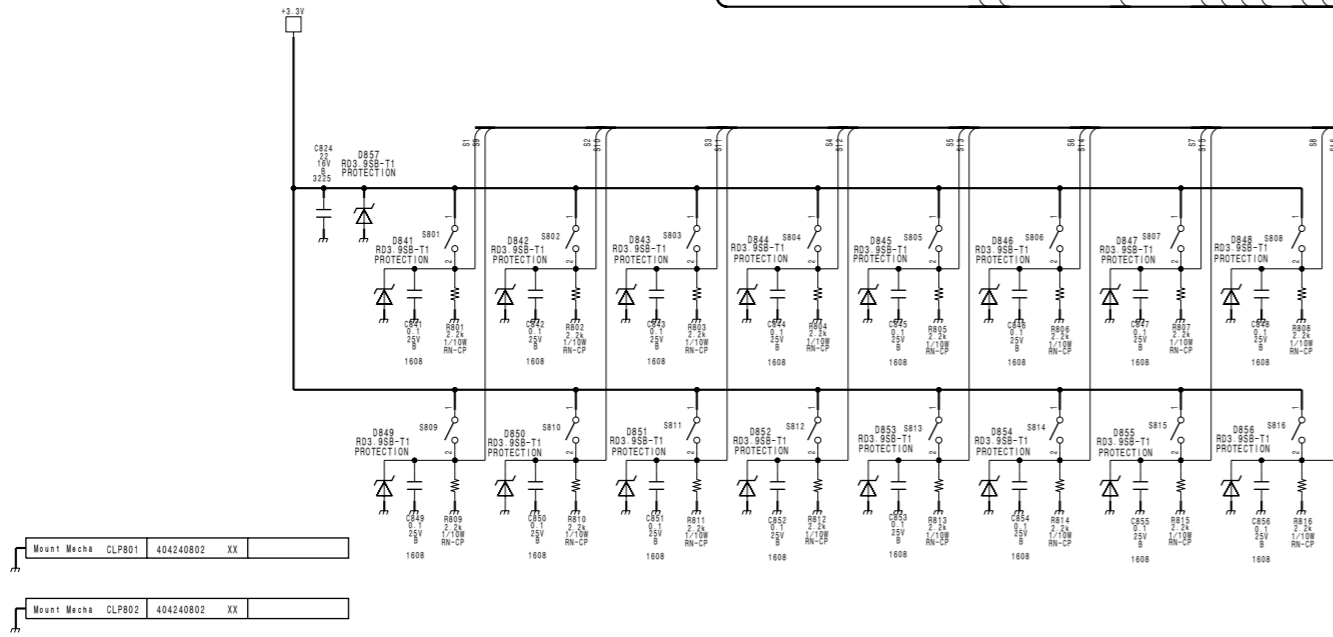
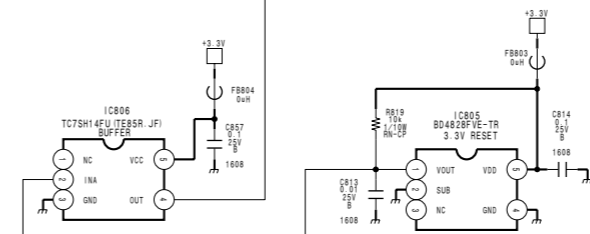
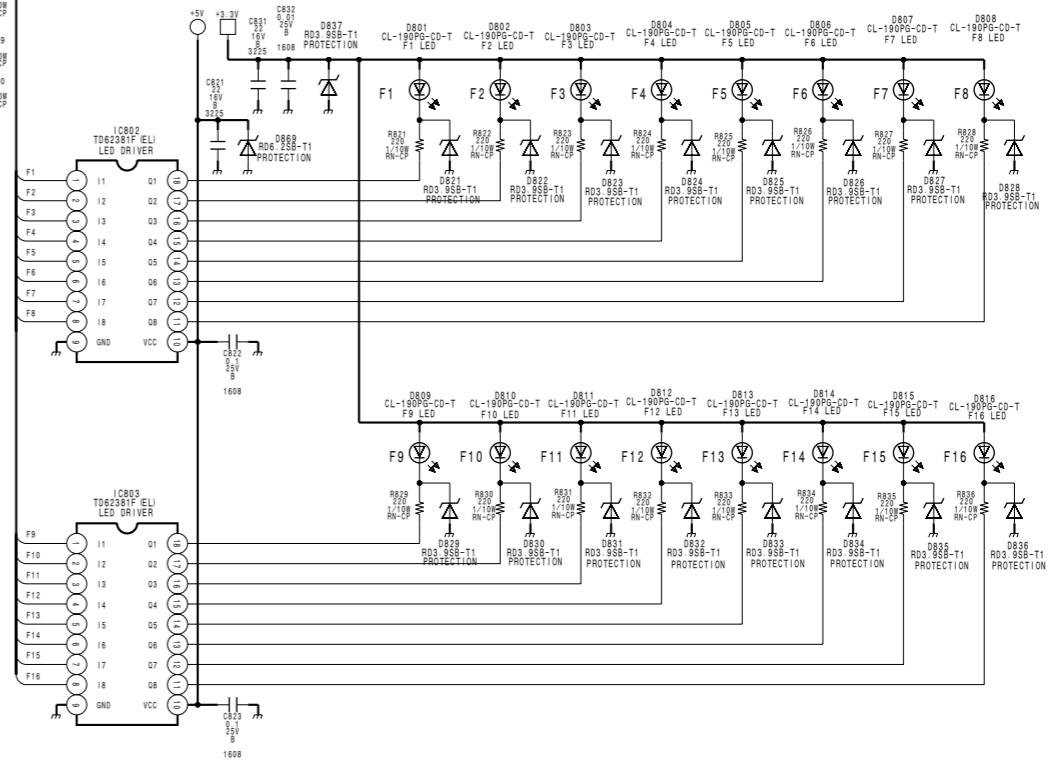
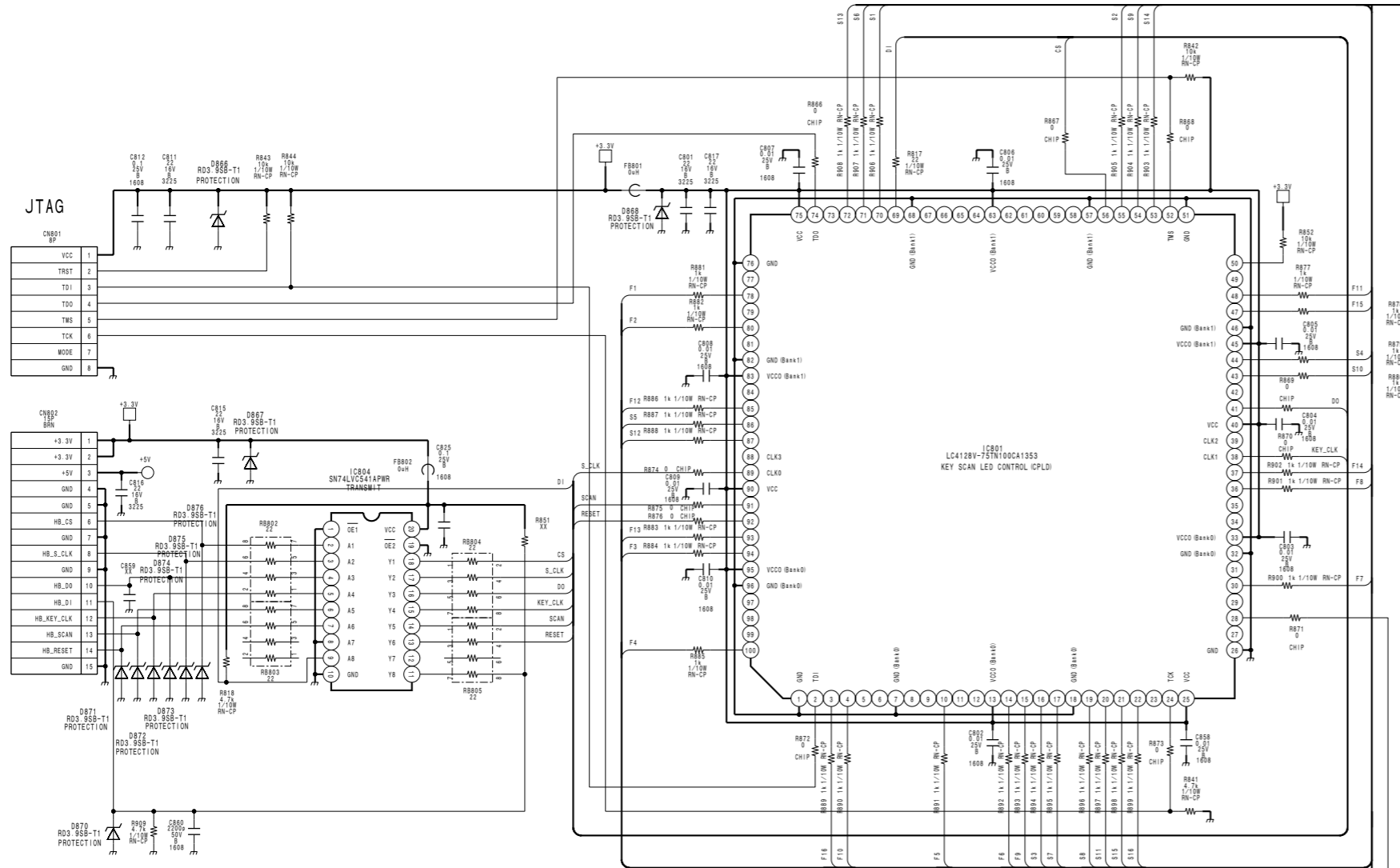

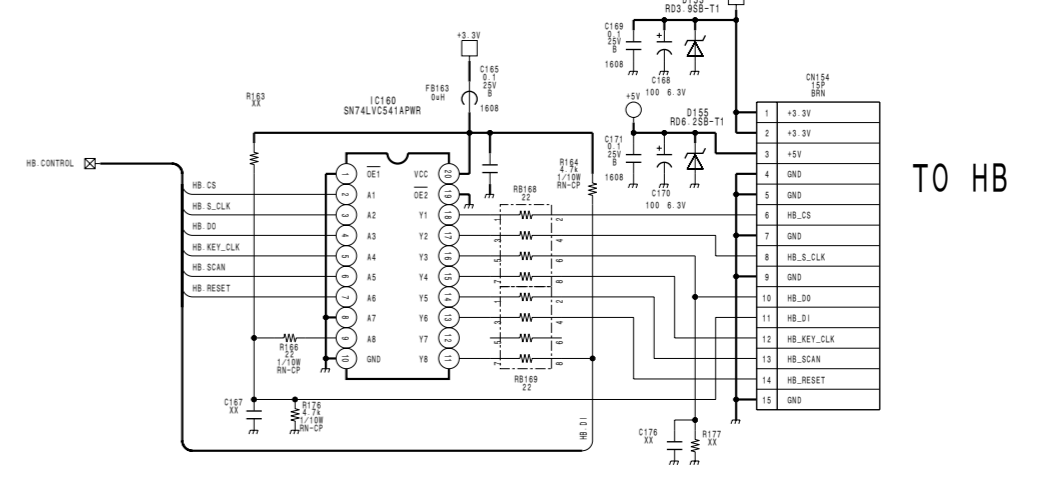
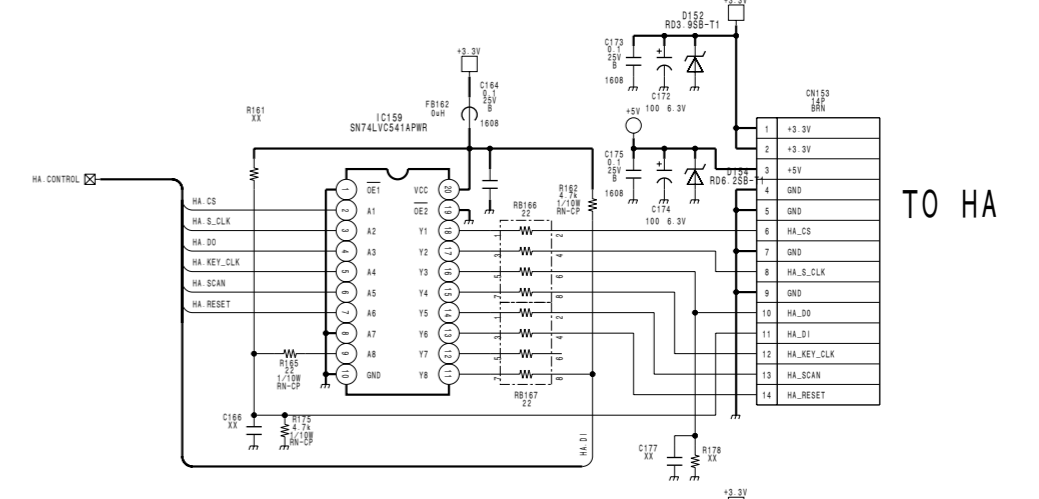
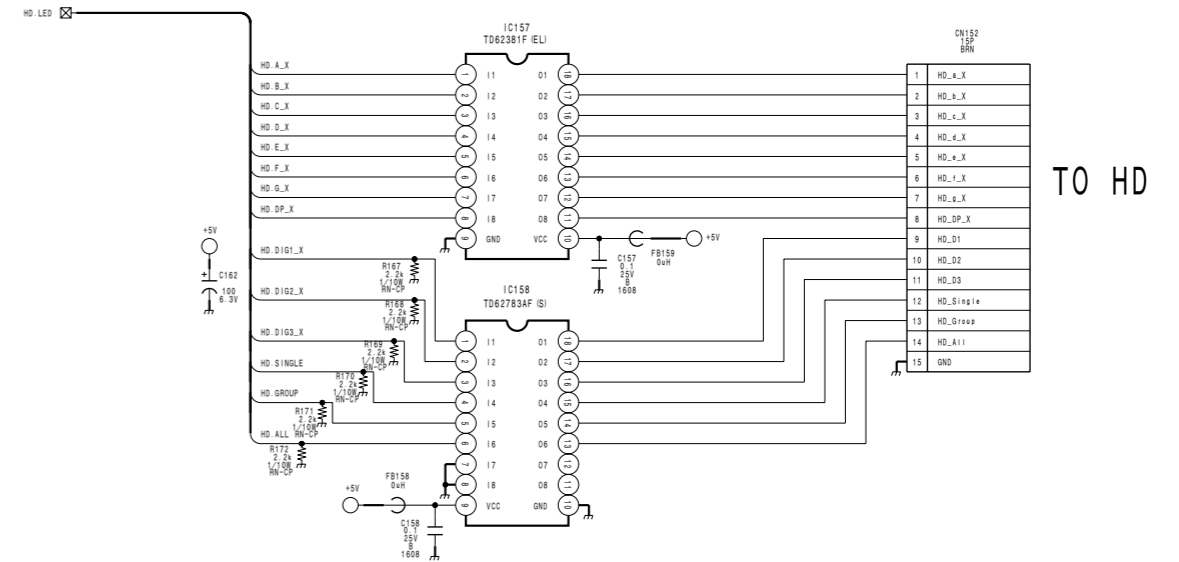
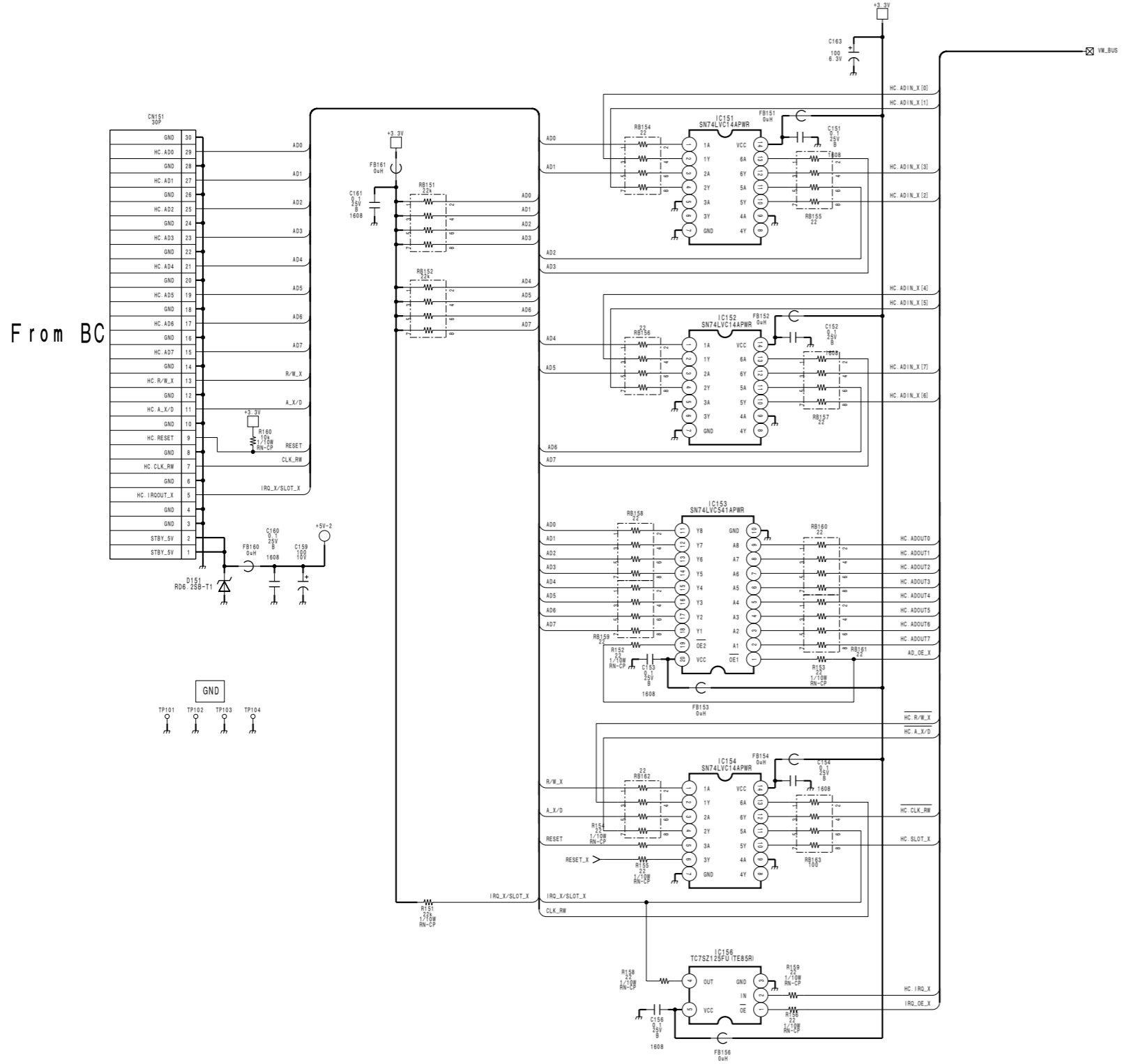

1

2

3

4

5

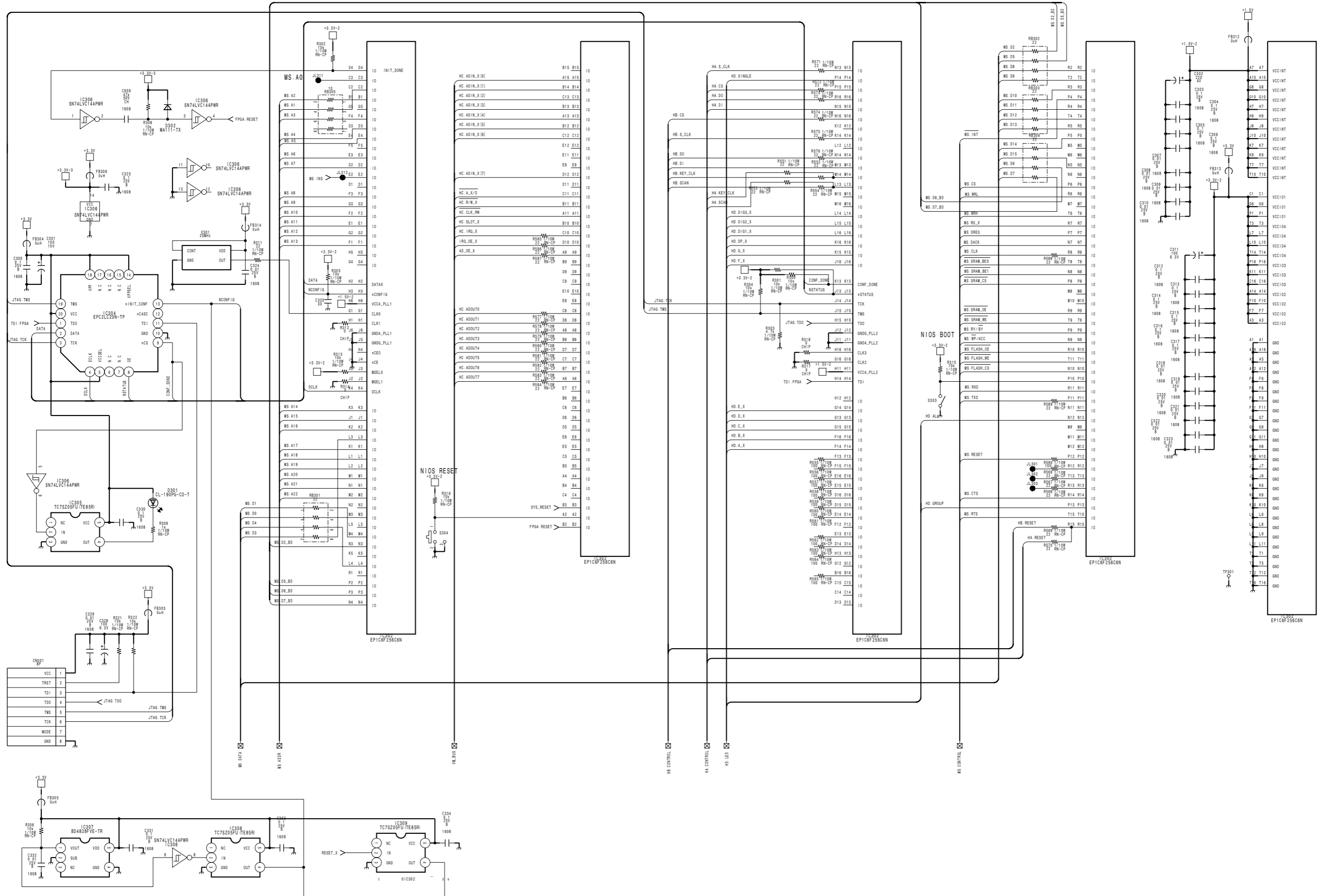

HC (4/4) HC (4/4)

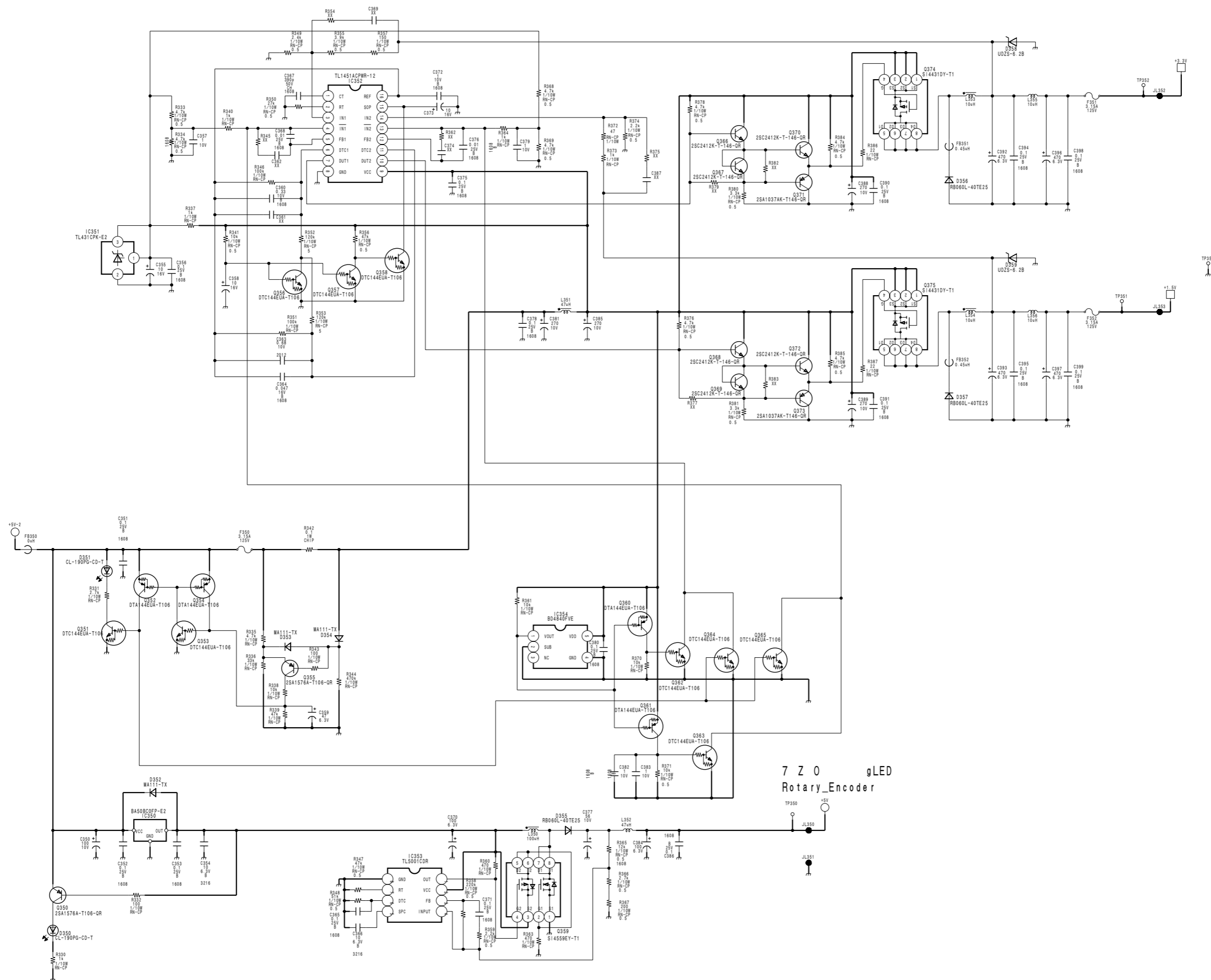

8-42

8-42

BVM-A14

A B C D E F G H

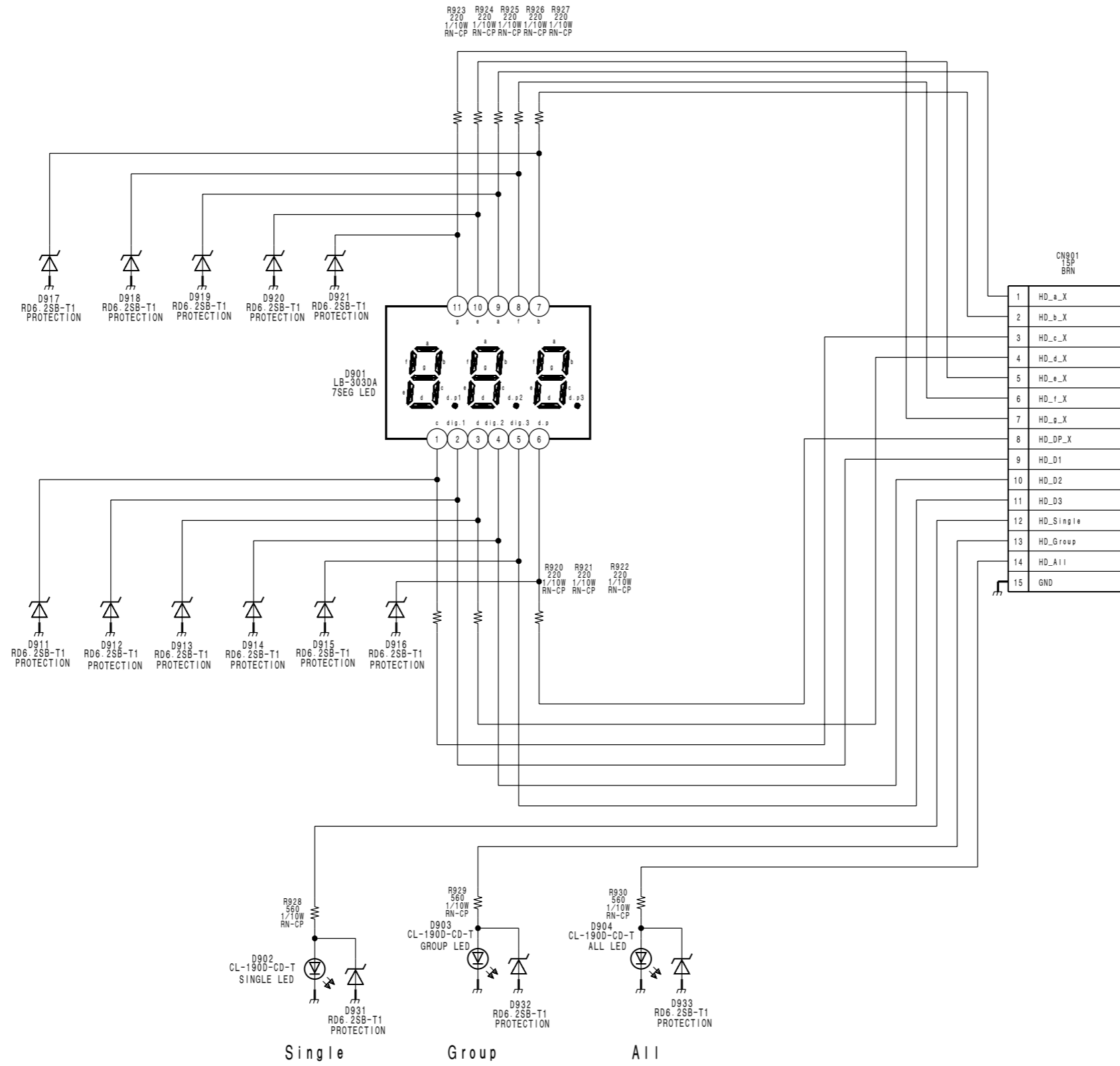

Remote

1
2
3
4
5

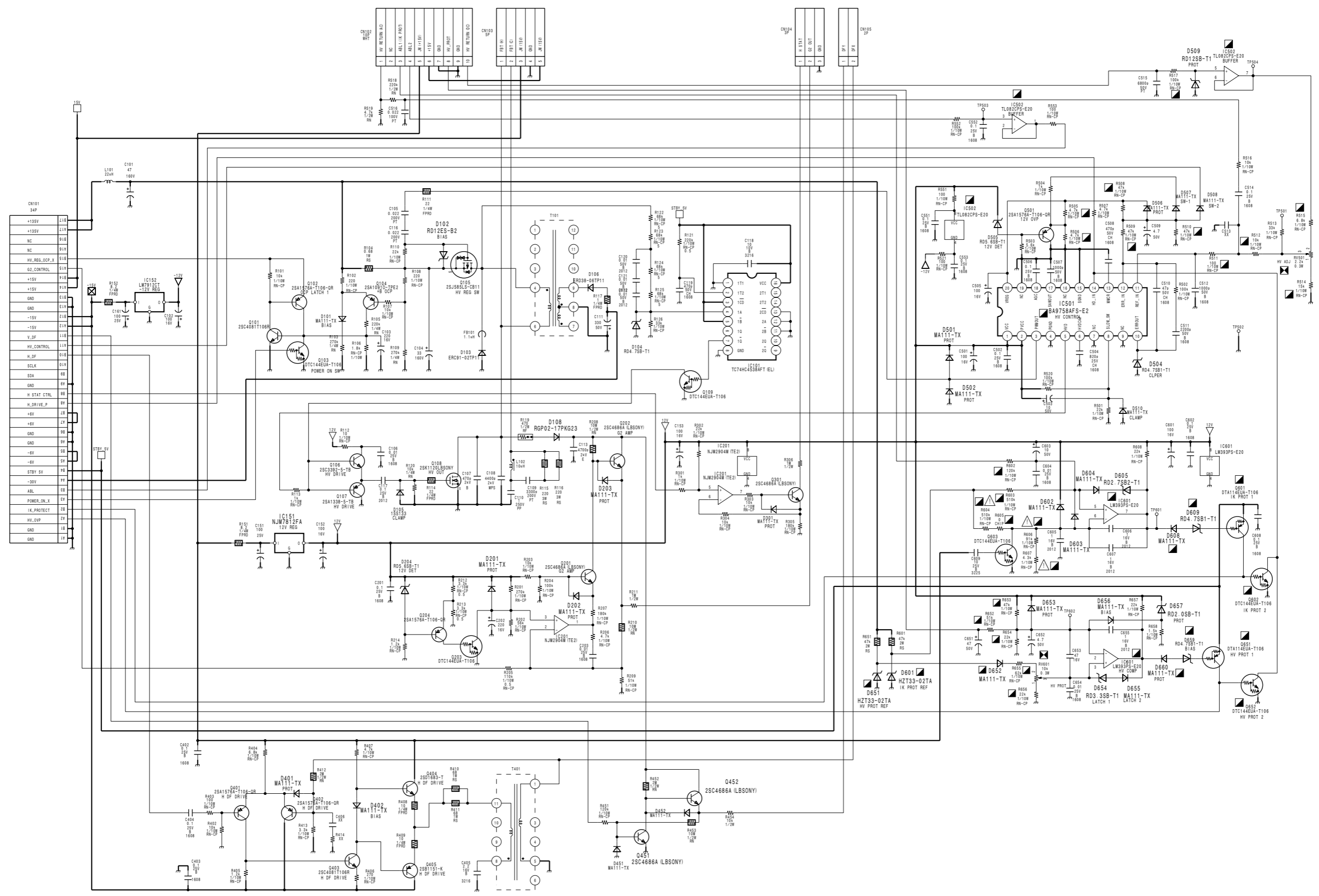

Mount Mechs	A002	X40343062	Q108
Mount Mechs	A003	403694891	Q404
Mount Mechs	A004	403694891	Q405

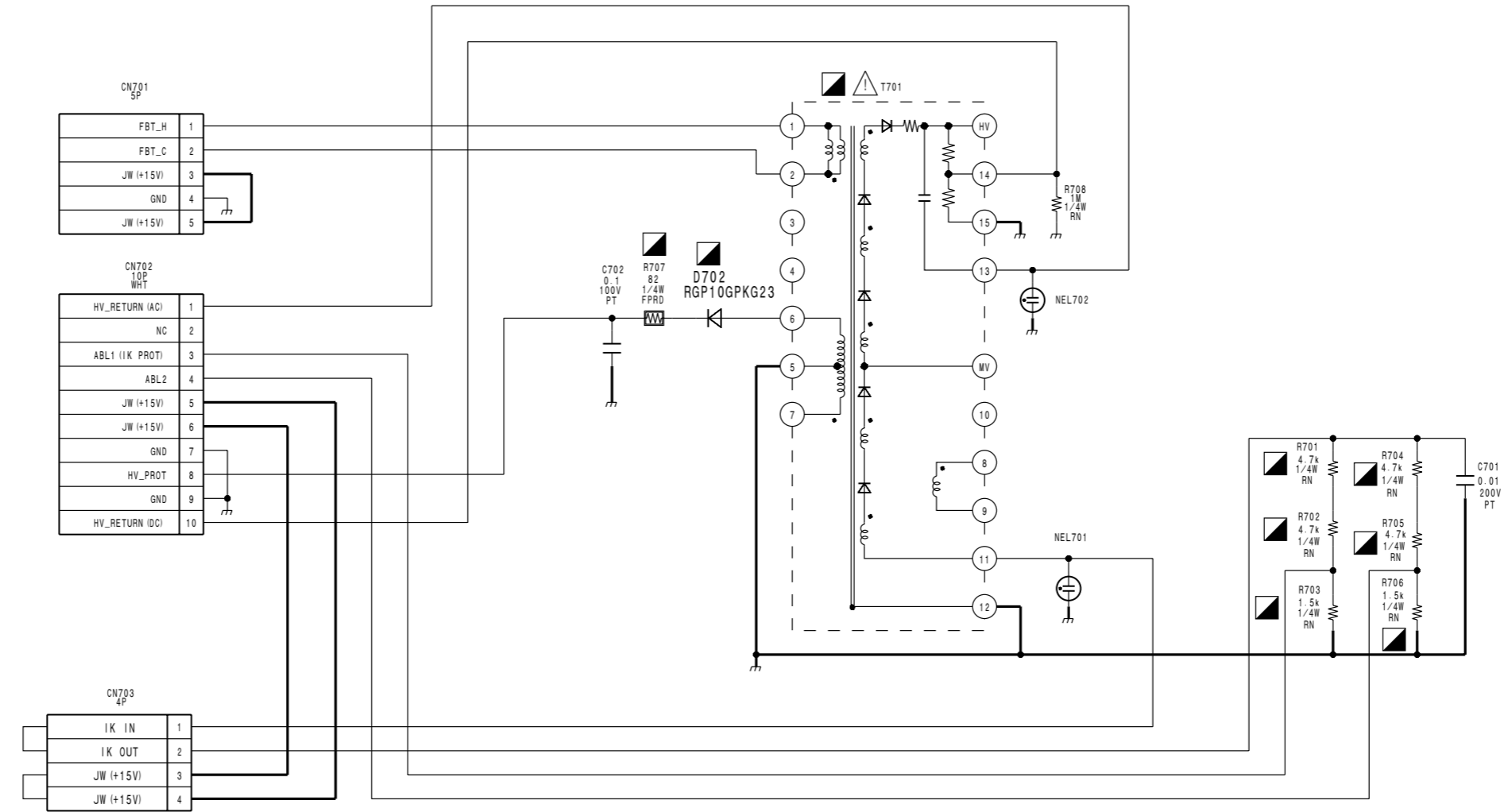

Mount Mecha	A001	406109902	T701
-------------	------	-----------	------

1

2

3

4

5

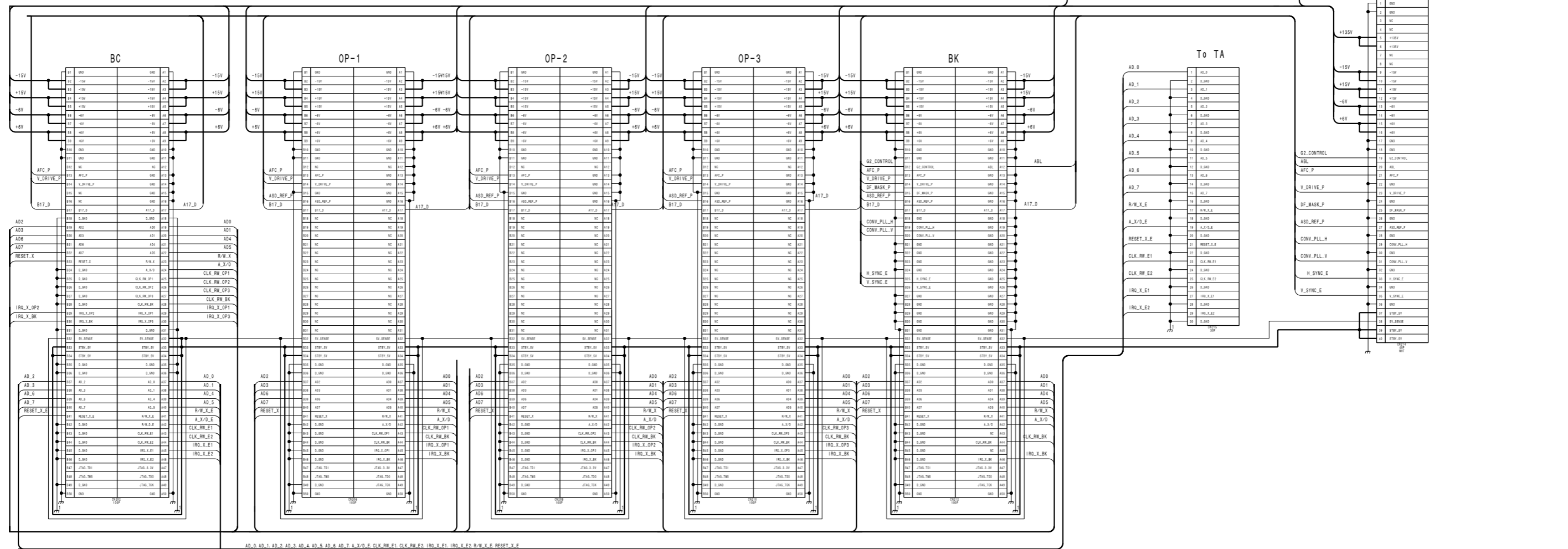
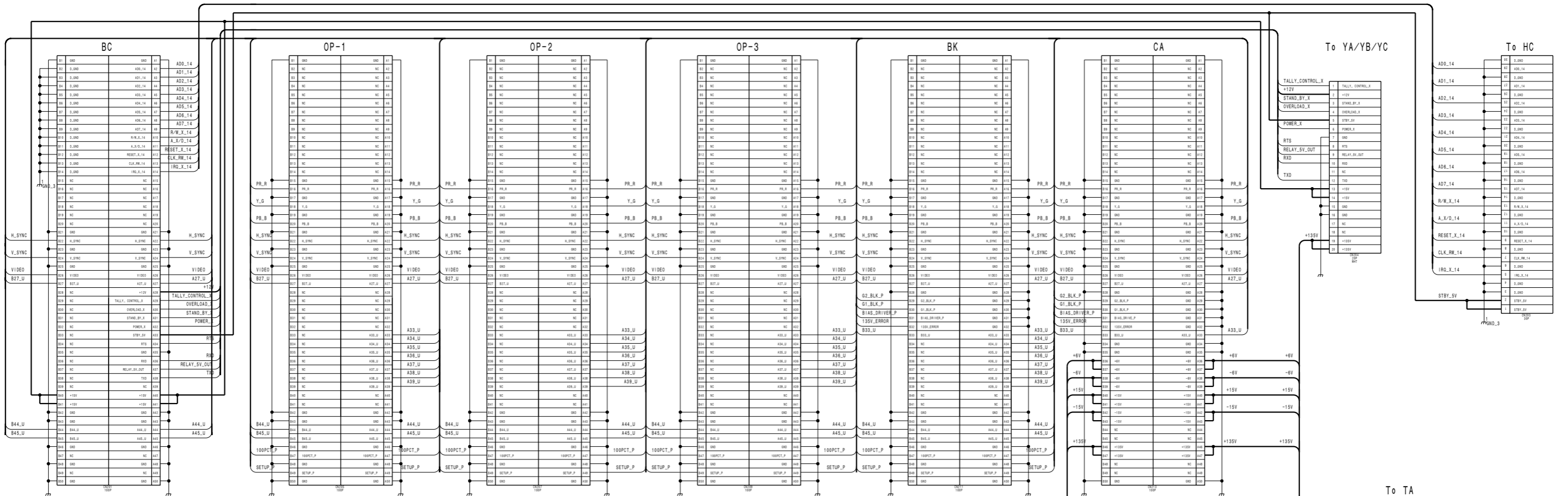

1

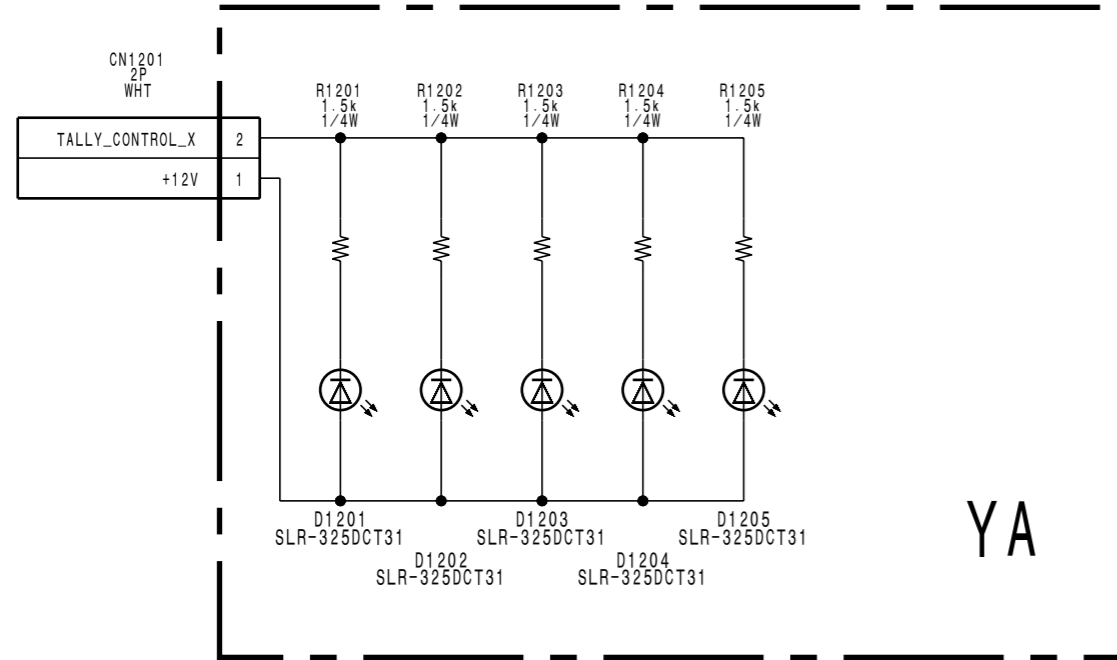

YA

2

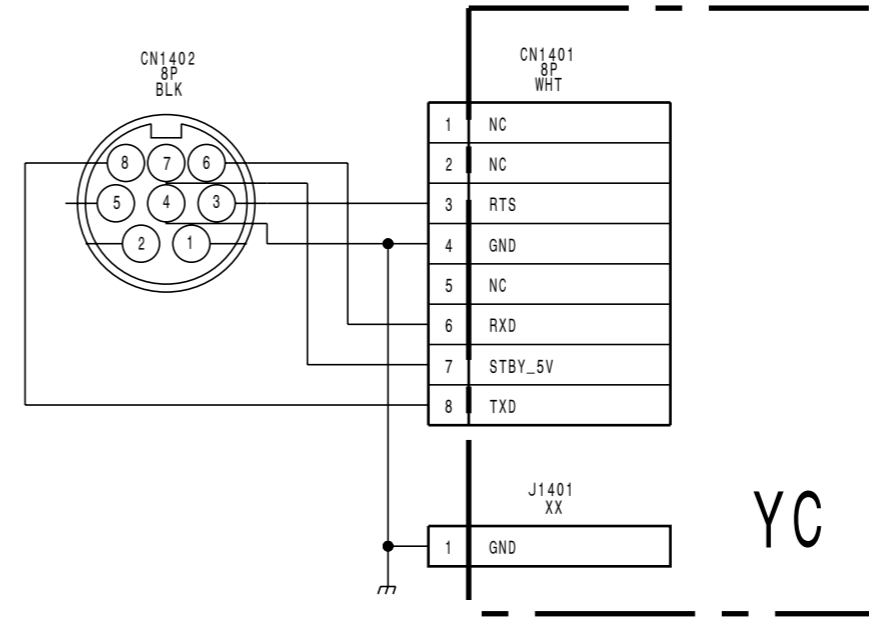

YC

3

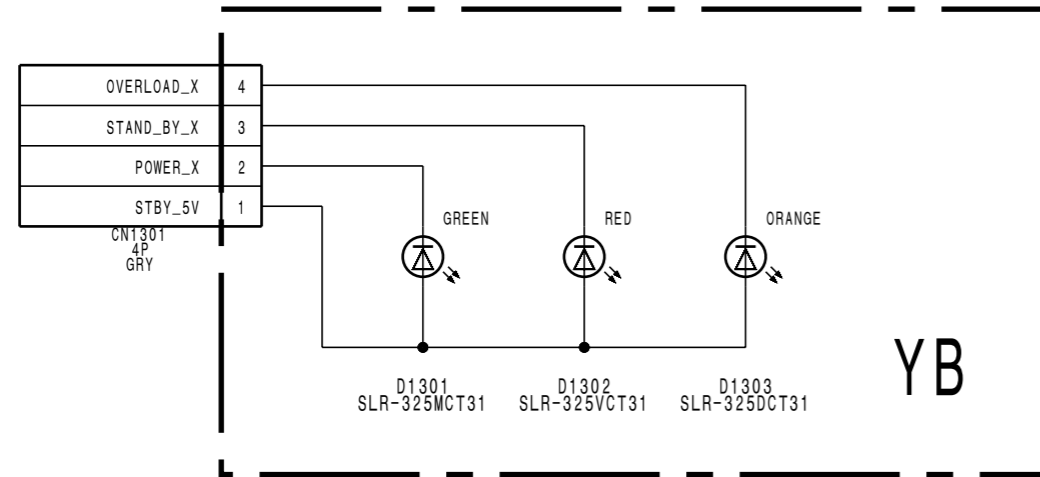

YB

4

5

Section 9 Board Layouts

Board Name	Function	Page
BC	MAIN CPU	9-2
BK	VIDEO PROCESSOR	9-4
C	R, G, B OUT	9-6
CA	R, G, B AMP	9-7
E	H/V OSC	9-9
EA	DEFLECTION PROCESSOR	9-11
G	SWITCHING REGULATOR	9-13
HA	KEY/ENCODER SCAN LED CONTROL	9-15
HB	KEY SCAN LED CONTROL	9-15
HC	MAIN CPU	9-16
HD	7 SEG LED	9-16
PA	H/V CONTROL	9-17
PC	FLYBACK TRANSFORMER	9-17
TA	MOTHER BOARD	9-18
TB	MOTHER BOARD	9-19
YA	TALLY LED	9-20
YB	PANEL LED	9-20
YC	OPTION JACK	9-20

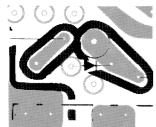

NOTE:
The circuit indicated as shown on the left contains high voltages of over 600 Vp-p. Take care to avoid electric shock during inspection or repair work.

BC BOARD

*: B SIDE

D011	G-2	IC311	*D-7
D012	G-2	IC312	*D-7
D013	G-2	IC313	*G-5
D014	H-1	IC350	F-8
D015	G-2	IC351	D-7
D100	H-9	IC352	A-6
D150	A-3	IC404	F-9
D151	A-3		
D152	A-3	Q150	B-3
D153	A-3	Q151	B-3
D154	A-3	Q152	B-3
D155	A-3	Q153	B-3
D156	A-4	Q350	E-8
D157	A-4	Q351	E-8
D158	A-4	Q352	E-8
D159	A-4	Q353	E-8
D160	A-3	Q354	E-9
D161	*J-3	Q355	E-9
D162	*J-3	Q356	E-9
D163	*J-3	Q357	E-9
D164	*J-2	Q358	C-8
D165	*J-3	Q360	F-9
D166	*J-3	Q361	F-9
D167	*J-3	Q362	F-9
D168	*J-3	Q363	F-8
D251	*J-5	Q364	B-8
D252	*J-5	Q365	B-8
D253	*J-5	Q366	B-8
D254	*J-5	Q367	B-8
D255	*J-5	Q382	G-8
D256	*J-5	Q383	G-8
D257	*J-5		
D258	*J-5	TP001	E-3
D350	F-9	TP007	F-2
D351	F-9	TP008	G-3
D352	E-8	TP011	G-3
D353	E-9	TP150	C-6
D354	C-8	TP151	C-6
D355	D-7	TP152	C-6
D356	C-8	TP250	G-7
D357	A-6	TP251	G-7
D358	H-8	TP300	C-6
D359	F-8	TP302	E-7
D360	G-8	TP306	E-7
D361	B-8	TP307	F-6
D362	H-8	TP308	E-7
		TP309	D-7
		TP350	C-9
IC001	F-4	TP351	C-7
IC010	G-4	TP352	H-8
IC011	G-3	TP353	F-9
IC012	G-2	TP354	A-5
IC013	G-3		
IC014	G-1		
IC015	G-3		
IC016	G-1		
IC017	F-2		
IC018	*G-4		
IC100	G-6		
IC101	*G-6		
IC102	D-4		
IC103	E-4		
IC104	H-9		
IC106	G-7		
IC107	H-9		
IC108	G-5		
IC109	*G-7		
IC110	*G-6		
IC150	C-5		
IC151	B-2		
IC152	B-2		
IC153	B-2		
IC154	B-7		
IC155	B-7		
IC156	B-1		
IC157	B-2		
IC158	B-7		
IC159	B-6		
IC160	B-8		
IC161	B-9		
IC162	B-8		
IC163	B-9		
IC164	B-8		
IC165	B-8		
IC166	H-2		
IC167	H-3		
IC168	B-5		
IC250	J-7		
IC251	J-6		
IC252	H-7		
IC253	G-7		
IC254	J-5		
IC255	B-4		
IC256	*H-7		
IC257	G-7		
IC258	J-6		
IC300	E-6		
IC301	C-7		
IC302	C-7		
IC303	C-7		
IC310	*D-8		

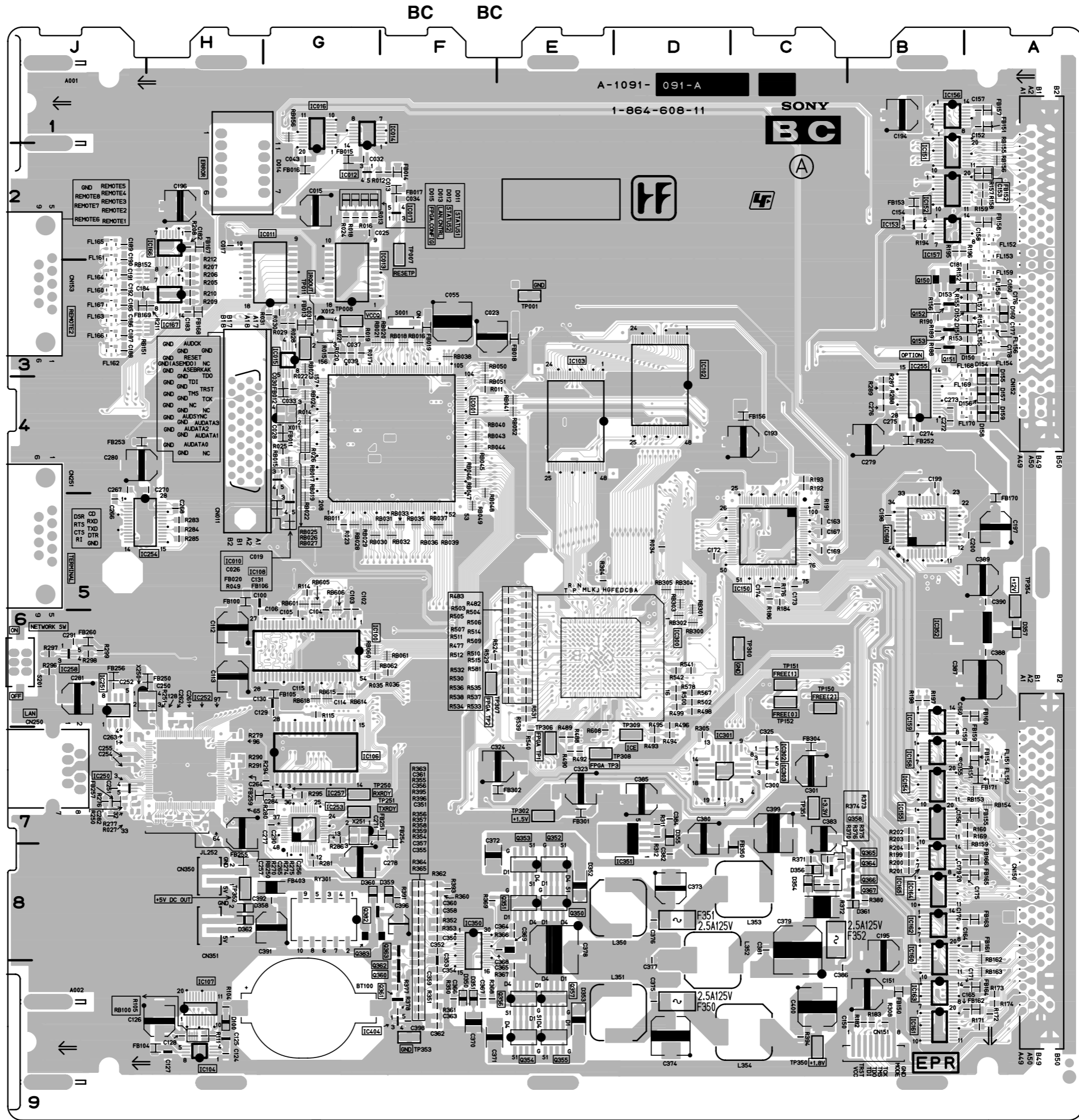

BC - A SIDE-
SUFFIX: -11

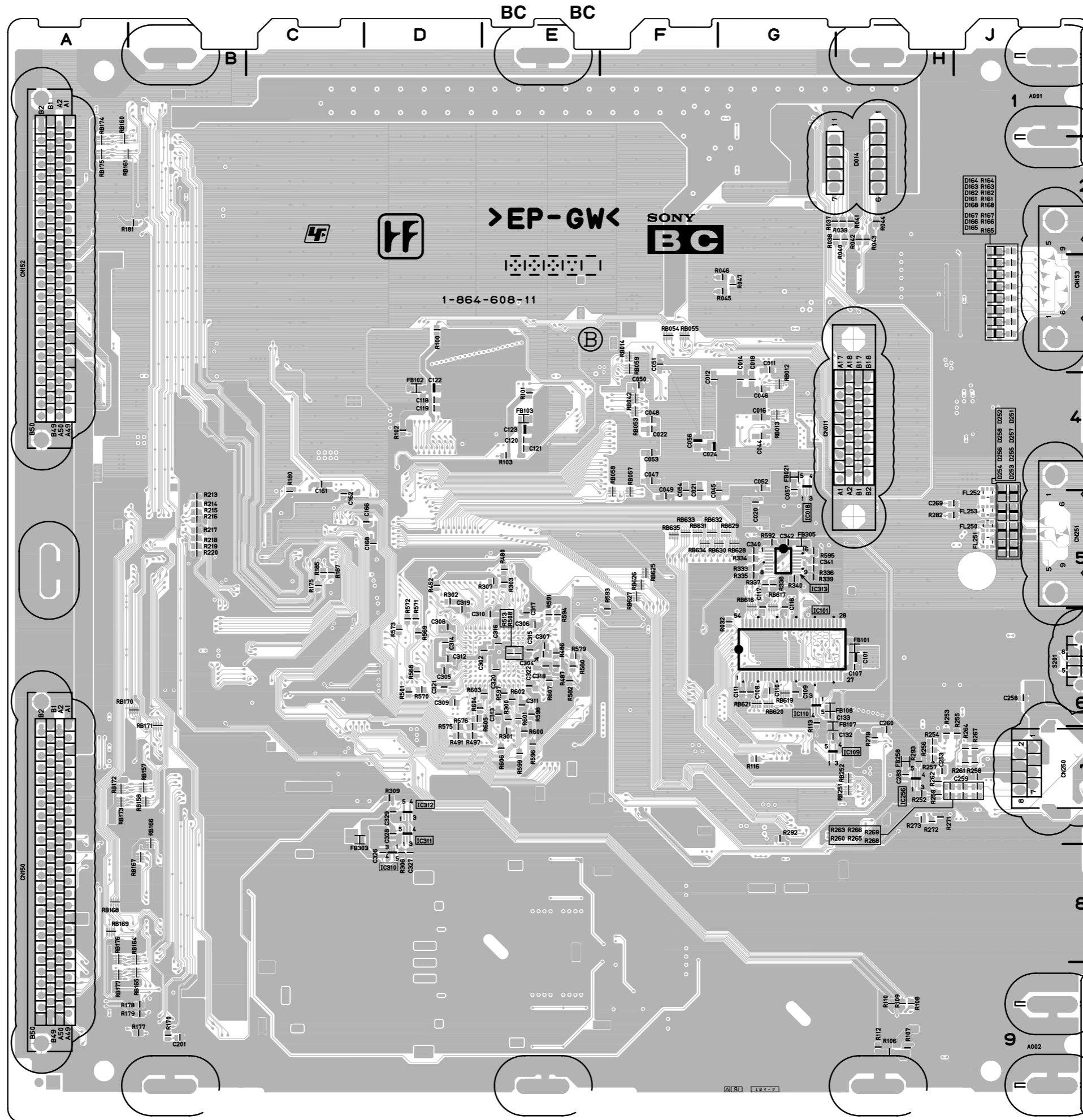

BC-B SIDE-
SUFFIX: -11

BK BOARD

*: B SIDE

D040	* J-8	IC527	* C-5	Q040	* G-8	TP001	F-9
D151	A-4	IC550	* D-4	Q041	* G-8	TP002	F-9
D152	B-4	IC551	* C-4	Q042	* H-8	TP003	A-8
D351	C-4	IC552	* C-4	Q043	* G-8	TP004	E-9
D352	C-4	IC553	* D-3	Q044	* H-8	TP005	B-8
D551	D-4	IC600	E-7	Q150	A-4	TP006	B-8
D552	D-4	IC601	E-7	Q151	B-4	TP007	C-8
D600	E-7	IC602	D-7	Q152	B-4	TP008	C-8
D601	E-7	IC603	E-6	Q153	A-4	TP009	D-8
D602	E-7	IC605	D-7	Q154	A-4	TP010	E-8
D603	E-7	IC650	E-7	Q155	A-4	TP011	G-8
D604	E-7	IC653	F-7	Q350	B-4	TP012	D-8
D700	H-8	IC654	E-2	Q351	C-4	TP040	J-8
D740	J-5	IC700	* G-7	Q352	C-4	TP041	J-8
D800	H-1	IC701	G-7	Q353	B-4	TP042	G-8
D801	H-1	IC703	H-7	Q354	B-4	TP100	B-6
D802	* J-2	IC704	* H-7	Q550	D-4	TP101	A-6
D803	* G-2	IC705	G-7	Q551	D-4	TP120	A-5
D804	H-3	IC740	J-7	Q552	D-4	TP121	A-4
D805	* H-4	IC741	J-6	Q553	C-4	TP150	A-3
D900	H-5	IC742	J-5	Q554	C-4	TP200	B-6
D1000	F-1	IC750	G-7	Q650	E-2	TP300	B-7
D1001	F-1	IC760	F-7	Q651	E-2	TP301	B-6
D1002	* G-2	IC761	F-7	Q652	E-2	TP320	B-5
D1003	* E-2	IC762	F-6	Q653	F-7	TP321	B-4
D1004	F-3	IC763	F-7	Q700	H-8	TP350	B-3
D1005	* F-3	IC764	F-7	Q740	J-6	TP400	C-7
D1140	* B-2	IC765	F-7	Q750	G-7	TP500	C-6
D1340	* C-2	IC800	H-1	Q751	G-7	TP501	D-6
D1540	* D-2	IC900	H-5	Q800	* H-1	TP520	C-5
		IC902	G-5	Q801	* H-2	TP521	C-4
IC001	D-8	IC903	* G-6	Q802	* G-1	TP550	C-3
IC002	B-7	IC904	G-4	Q803	* G-2	TP600	E-7
IC003	B-9	IC905	* G-5	Q804	* J-2	TP601	E-7
IC004	B-7	IC906	* G-6	Q805	* J-1	TP602	D-7
IC005	C-9	IC907	J-5	Q806	* H-1	TP650	F-7
IC006	C-7	IC930	J-4	Q807	* H-2	TP651	E-2
IC007	C-9	IC931	F-4	Q808	H-3	TP800	H-4
IC008	D-9	IC932	F-4	Q809	* H-1	TP801	H-4
IC009	E-9	IC933	F-5	Q810	* H-4	TP802	H-6
IC040	G-9	IC934	G-4	Q811	* H-4	TP1000	F-4
IC041	H-8	IC935	F-4	Q812	* H-4	TP1001	F-4
IC042	H-8	IC936	F-4	Q900	* H-6	TP1100	A-2
IC043	J-8	IC937	F-5	Q901	H-5	TP1300	B-2
IC044	* J-8	IC938	H-4	Q931	G-5	TP1500	C-2
IC045	H-9	IC939	F-5	Q932	G-5	TP1900	E-4
IC046	H-9	IC1000	F-1	Q933	H-4	TP1901	E-4
IC047	H-9	IC1100	A-3	Q934	H-5		
IC048	J-9	IC1101	* A-3	Q935	H-5		
IC049	J-9	IC1102	* A-2	Q1000	* F-1		
IC050	J-9	IC1103	* A-2	Q1001	* F-2		
IC051	H-9	IC1140	* B-2	Q1002	* E-1		
IC100	* A-7	IC1141	* B-2	Q1003	* E-2		
IC101	* A-7	IC1170	* B-3	Q1004	* G-2		
IC102	* A-7	IC1171	* B-4	Q1005	* G-1		
IC103	* A-6	IC1174	* B-3	Q1006	* F-1		
IC120	* A-6	IC1175	* B-3	Q1007	* F-2		
IC121	* A-6	IC1176	* B-2	Q1008	* F-3		
IC122	* A-5	IC1177	* B-2	Q1009	* F-1		
IC123	* B-5	IC1178	A-2	Q1010	* F-4		
IC124	* A-5	IC1179	B-2	Q1011	* F-4		
IC125	* A-5	IC1300	B-3	Q1012	* F-4		
IC150	* B-4	IC1301	* B-3	Q1100	B-1		
IC151	* A-4	IC1302	* C-2	Q1101	B-1		
IC152	* A-4	IC1303	* B-2	Q1102	B-2		
IC153	* A-3	IC1340	* C-2	Q1140	B-2		
IC200	* B-7	IC1341	* C-2	Q1141	B-2		
IC201	* B-7	IC1370	* C-3	Q1300	C-1		
IC202	B-6	IC1371	* C-4	Q1301	C-1		
IC220	* B-6	IC1374	* C-3	Q1302	C-2		
IC300	* B-7	IC1375	* C-3	Q1340	C-2		
IC301	* B-7	IC1376	* C-2	Q1341	C-2		
IC302	* B-7	IC1377	* C-2	Q1500	D-1		
IC303	* B-6	IC1378	B-2	Q1501	D-1		
IC320	* B-6	IC1379	C-2	Q1502	D-2		
IC321	* C-6	IC1500	C-3	Q1540	D-2		
IC322	* B-5	IC1501	* D-3	Q1541	D-2		
IC323	* C-5	IC1502	* D-2	Q1700	E-7		
IC324	* B-5	IC1503	* C-2	Q1701	E-8		
IC325	* B-5	IC1540	* D-2	Q1702	E-7		
IC350	* C-4	IC1541	* D-2	Q1703	E-7		
IC351	* B-4	IC1570	* D-3	Q1704	D-7		
IC352	* B-4	IC1571	* D-4	Q1705	D-8		
IC353	* B-3	IC1574	* D-3	Q1706	D-8		
IC400	* C-7	IC1575	* D-3	Q1900	E-5		
IC401	* C-7	IC1576	* D-2	Q1901	E-5		
IC402	C-6	IC1577	* D-2	Q1902	E-5		
IC420	* C-4	IC1578	C-2	Q1903	E-5		
IC421	* C-4	IC1579	D-2	Q1904	E-5		
IC500	* C-7	IC1700	D-7	Q1905	F-5		
IC501	* C-7	IC1701	F-8	Q1906	E-5		
IC502	* C-7	IC1900	E-6	Q1907	E-5		
IC503	* C-6	IC1901	E-4	Q1908	F-5		
IC520	* C-6	IC1902	E-4	Q1909	E-4		
IC521	* C-6	IC1903	E-4	Q1910	E-4		
IC522	* C-6	IC1904	* E-4	Q1911	F-4		
IC523	* C-5			Q1912	E-4		
IC524	* D-5			Q1913	E-4		
IC525	* C-5			Q1914	F-4		

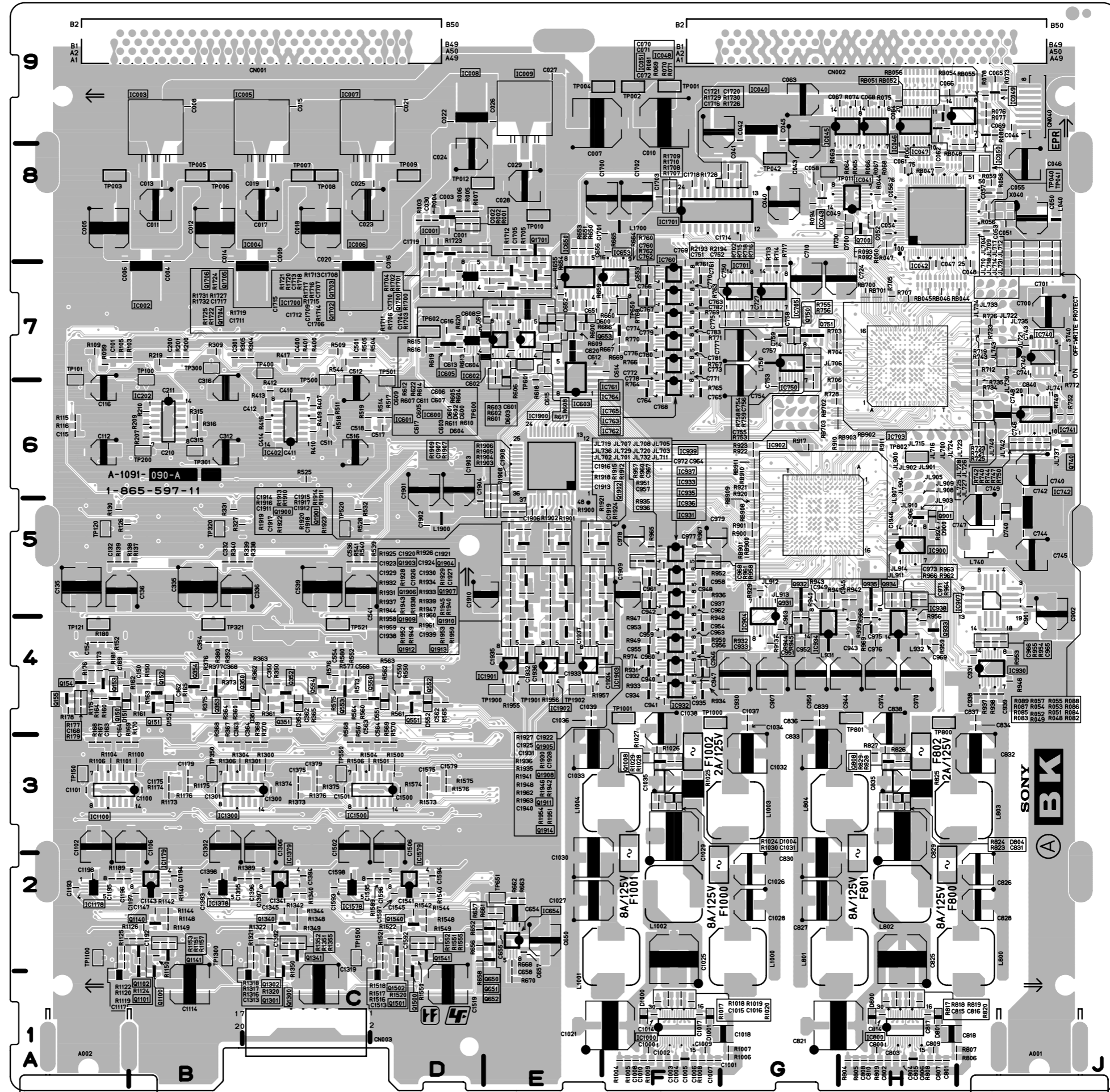

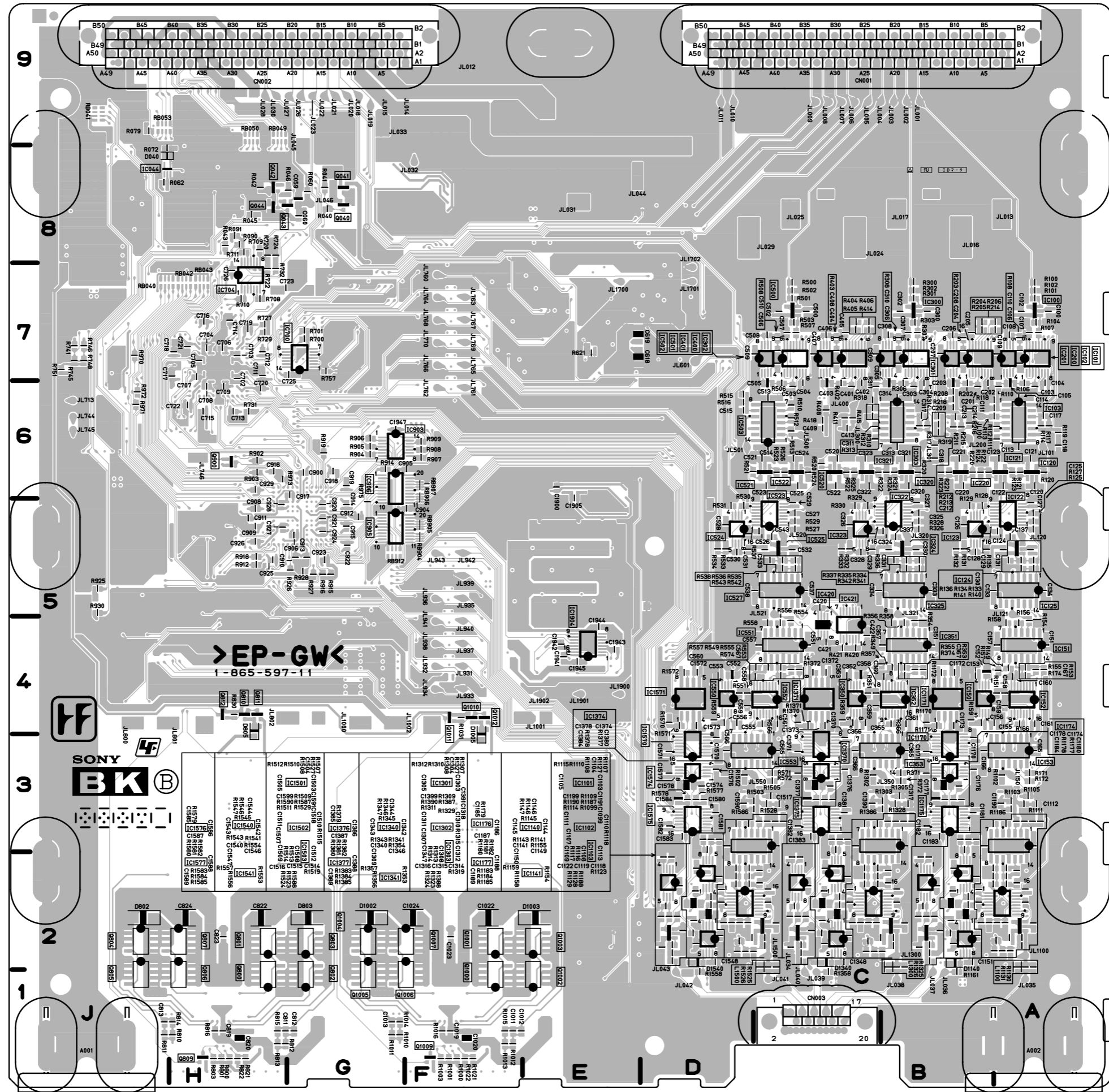

BK - B SIDE -
SUFFIX: -11

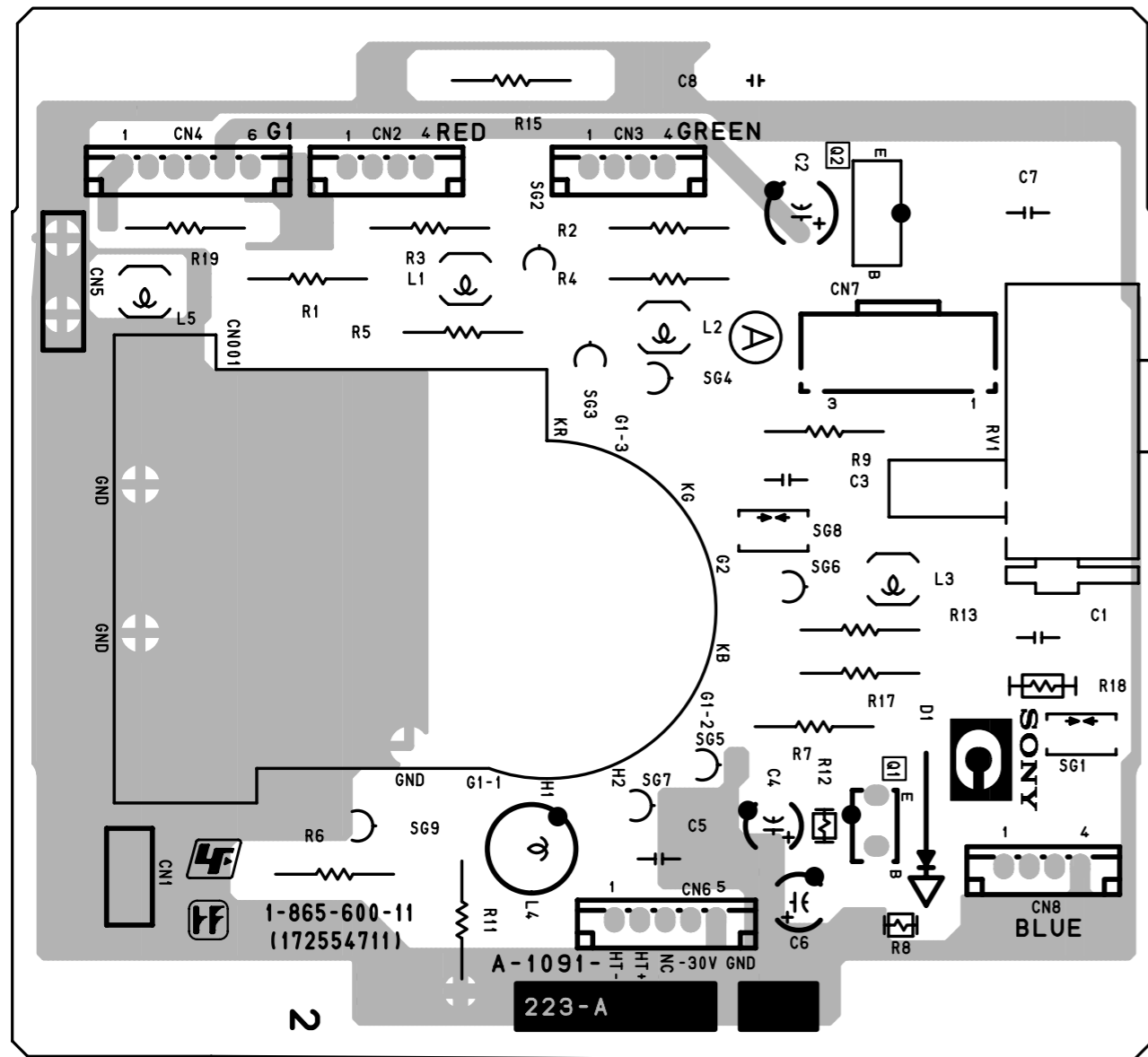

C -A SIDE-
SUFFIX: -11

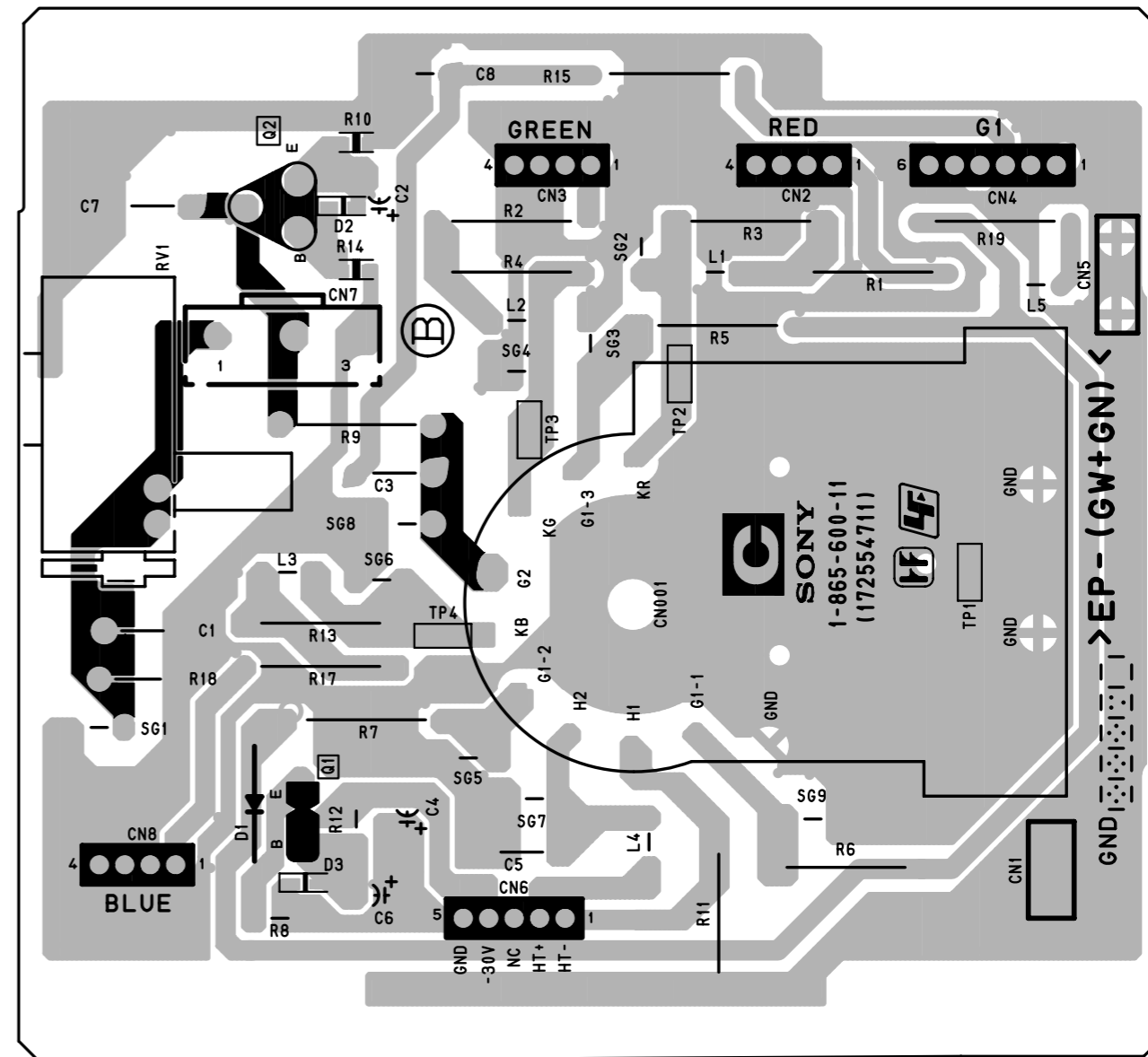

C -B SIDE-
SUFFIX: -11

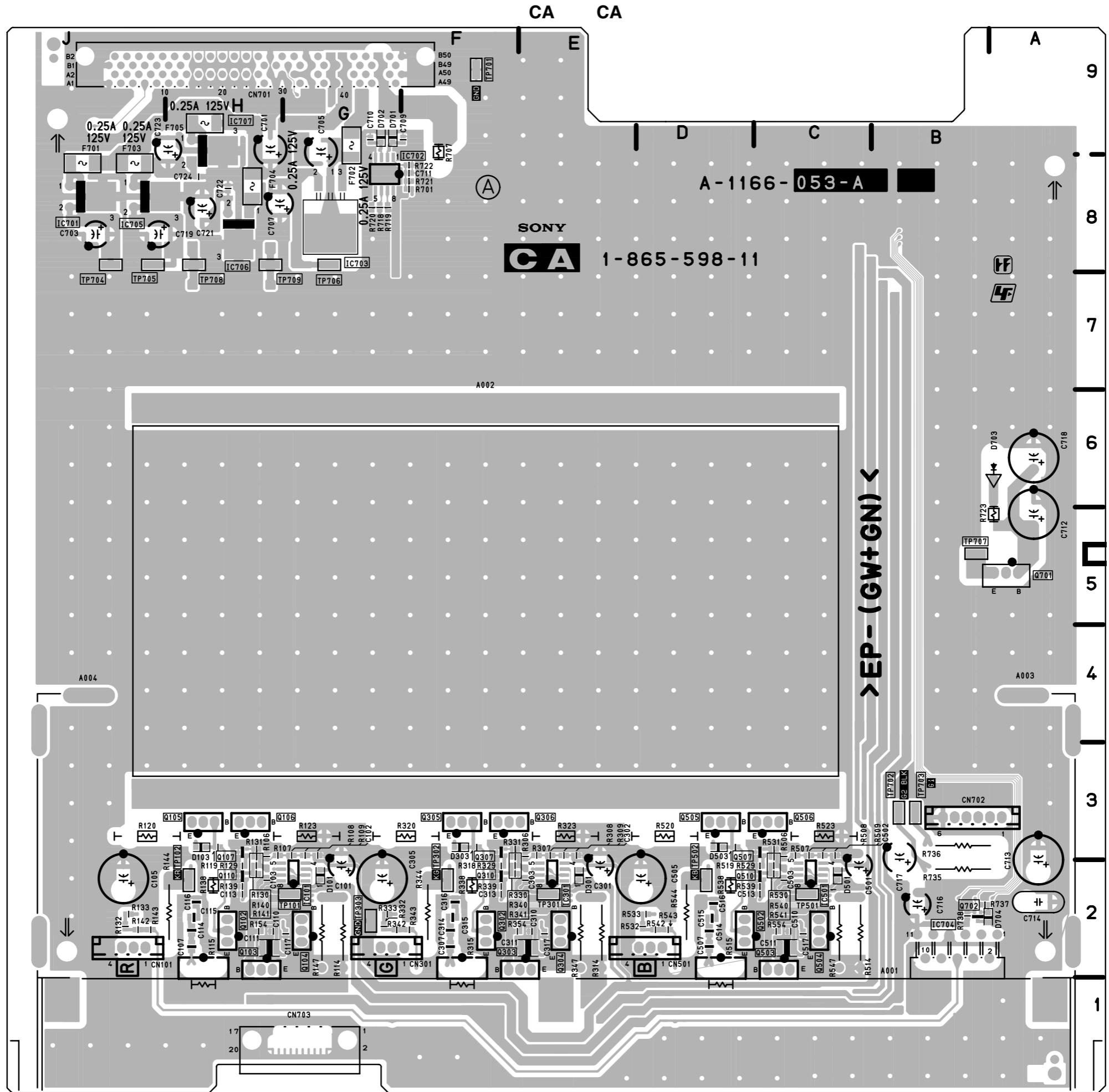

CA -A SIDE-
SUFFIX: -11

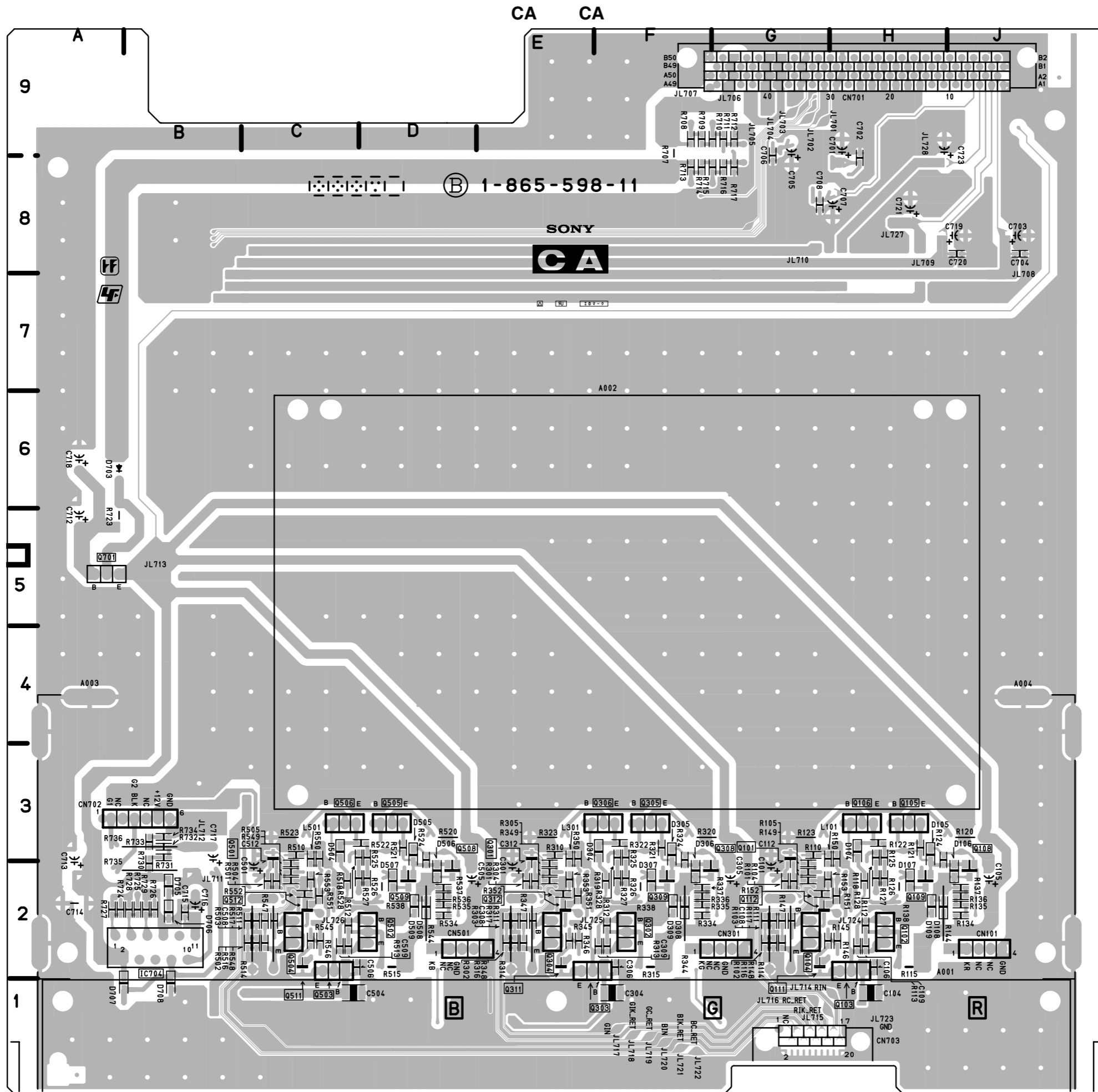

CA -B SIDE-
SUFFIX: -11

E BOARD

*: B SIDE

D1	*D-6	IC502	D-8	Q611	B-1
D2	C-1	IC600	B-2	Q612	B-1
D3	C-2	IC601	B-2	Q613	B-1
D4	G-9	IC602	B-3	Q614	B-1
D5	C-2	IC700	*H-2	Q615	B-1
D6	F-6	IC800	B-7	Q616	C-5
D7	G-2	IC801	B-7	Q617	B-1
D8	G-2	IC802	J-7	Q618	C-5
D9	H-7			Q619	C-5
D10	J-3	Q1	D-6	Q620	*C-5
D11	J-5	Q2	D-6	Q621	B-1
D12	D-1	Q3	D-6	Q622	*B-1
D13	D-1	Q4	E-6	Q623	*B-1
D14	C-2	Q5	F-3	Q624	B-1
D15	C-1	Q6	G-9	Q625	*B-2
D16	C-2	Q7	*C-1	Q626	*B-2
D17	C-2	Q8	F-3	Q627	*B-1
D18	D-5	Q9	F-5	Q628	*B-2
D19	J-3	Q10	*C-1	Q629	*B-2
D20	*H-3	Q11	F-4	Q630	*B-2
D21	*H-3	Q12	F-3	Q631	*B-2
D200	C-3	Q13	F-3	Q632	*B-3
D201	D-4	Q14	F-4	Q633	*B-3
D202	D-4	Q15	D-3	Q700	J-2
D203	D-4	Q16	J-6	Q701	J-1
D204	D-4	Q17	J-3	Q800	B-6
D205	C-4	Q18	E-3	Q801	B-6
D206	C-4	Q19	D-2	Q802	*B-6
D207	C-3	Q20	J-4	Q803	*B-7
D208	D-3	Q21	E-4	Q900	B-4
D209	C-3	Q22	F-4		
D210	C-3	Q23	D-4	TH801	H-9
D211	C-3	Q24	C-1		
D212	C-3	Q25	C-2	TP1	F-9
D213	C-2	Q26	D-3	TP2	J-6
D214	C-2	Q27	D-4	TP3	J-5
D216	C-2	Q28	C-3	TP100	B-8
D217	C-2	Q29	C-2	TP101	C-5
D300	B-8	Q30	C-3	TP102	J-3
D301	B-8	Q31	C-1	TP103	B-9
D401	D-6	Q32	D-3	TP104	G-7
D402	D-6	Q33	C-2	TP105	B-6
D403	D-6	Q34	C-4	TP106	D-6
D404	D-6	Q35	C-1	TP107	B-6
D405	D-6	Q36	C-4	TP108	E-7
D406	E-7	Q37	D-4	TP300	C-9
D407	E-7	Q38	D-4	TP700	J-2
D408	E-7	Q39	D-4	TP800	J-8
D409	*D-7	Q40	D-4	TP801	H-8
D410	*D-6	Q41	D-5		
D411	*F-9	Q42	*H-3		
D412	*F-9	Q100	*B-6		
D413	*G-8	Q101	*B-6		
D414	F-8	Q200	C-3		
D500	F-6	Q201	C-2		
D501	C-8	Q202	C-2		
D502	C-8	Q203	*C-2		
D503	C-8	Q204	*C-2		
D504	F-6	Q205	*C-2		
D505	D-8	Q206	*C-2		
D506	C-8	Q207	C-2		
D507	C-8	Q400	D-6		
D509	D-9	Q401	D-6		
D510	B-7	Q402	D-6		
D600	B-2	Q403	D-6		
D601	B-2	Q404	*D-7		
D602	B-2	Q405	D-6		
D603	*B-1	Q406	D-7		
D604	*B-1	Q407	E-7		
D605	*B-1	Q408	E-6		
D606	*B-2	Q410	F-9		
D607	*B-2	Q411	E-9		
D608	*B-2	Q412	E-9		
D609	*B-2	Q413	G-8		
D610	*B-2	Q414	E-9		
D611	*B-2	Q415	E-6		
D612	*B-2	Q500	D-8		
D613	*B-3	Q501	D-8		
D614	*B-3	Q502	D-8		
D615	*B-3	Q503	C-8		
D700	G-1	Q504	C-8		
D800	J-8	Q505	C-8		
D801	*H-8	Q506	C-8		
		Q507	B-7		
		Q508	B-7		
IC1	D-6	Q509	C-7		
IC2	D-5	Q510	C-8		
IC100	C-6	Q511	B-7		
IC101	C-7	Q600	C-5		
IC102	D-7	Q601	*C-5		
IC103	C-6	Q602	B-1		
IC104	B-3	Q603	C-5		
IC105	B-7	Q604	B-1		
IC106	*B-6	Q605	*B-4		
IC300	B-9	Q606	*C-5		
IC301	B-8	Q607	B-1		
IC400	D-6	Q608	B-1		
IC401	E-9	Q609	*B-4		
IC500	D-8	Q610	C-5		
IC501	D-8				

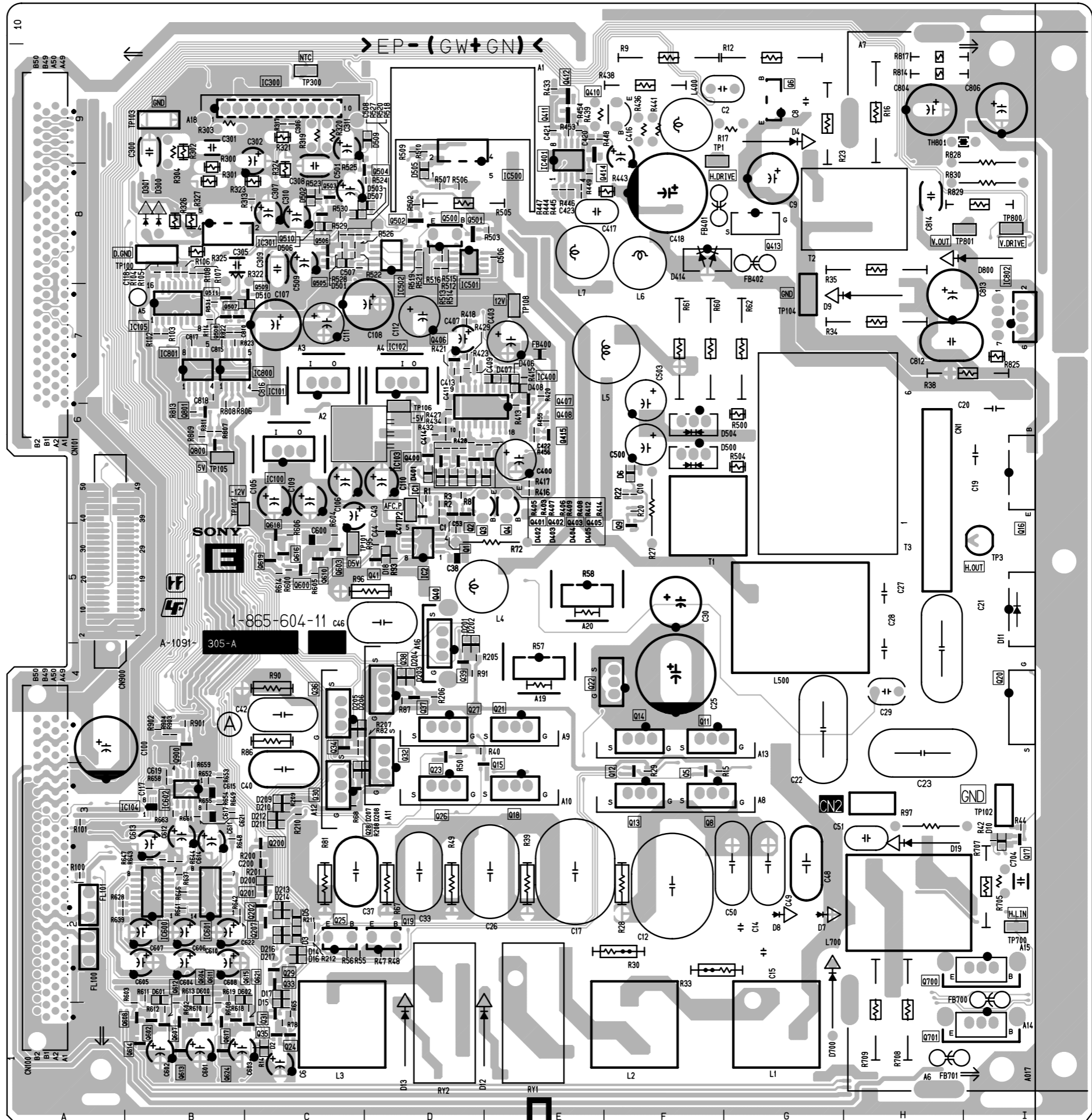

E - A SIDE -
SUFFIX: -11

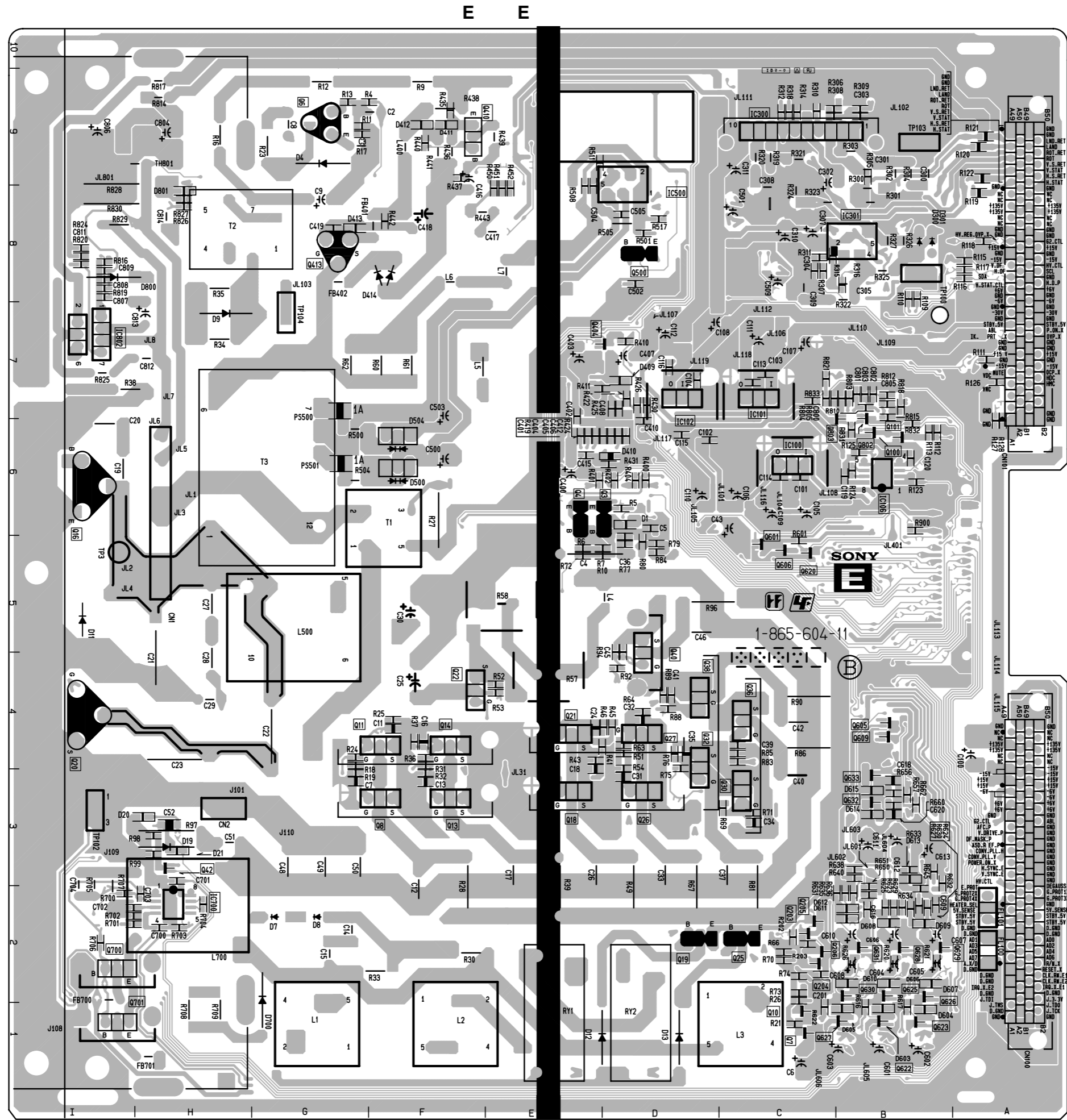

E - B SIDE-
SUFFIX: -11

EA BOARD

*: B SIDE

- D100 *D-3
- D101 *D-3
- D200 D-5
- D201 E-4
- D202 E-4
- D203 F-5
- D204 E-4
- D400 A-2
- D600 G-5
- D601 G-5
- D602 G-6
- D604 G-3
- D605 G-3
- D606 F-4
- D607 H-4
- D700 C-2

- Q100 F-3
- Q101 F-3
- Q102 E-3
- Q103 F-4
- Q104 *D-3
- Q105 *D-3
- Q106 *D-3
- Q107 *D-3
- Q108 *D-3
- Q109 *D-3
- Q200 C-6
- Q201 D-6
- Q202 E-4
- Q203 E-4
- Q204 E-4
- Q205 F-5
- Q206 F-5
- Q207 *F-5
- Q208 *E-6
- Q300 C-7
- Q301 C-7
- Q302 D-7
- Q500 *F-8
- Q501 *F-7
- Q502 *F-8
- Q503 *F-7
- Q504 *G-8
- Q505 *G-7
- Q506 *G-8
- Q507 *G-7
- Q508 *G-8
- Q509 *G-7
- Q510 *G-8
- Q511 *G-7
- Q512 G-8
- Q513 G-7
- Q514 G-8
- Q515 G-7
- Q516 G-8
- Q517 G-7
- Q518 G-8
- Q519 G-7
- Q603 G-5
- Q605 G-5
- Q606 G-5
- Q607 G-6
- Q608 G-6
- Q609 G-3
- Q610 G-4
- Q611 F-4
- Q612 F-3
- Q613 H-3
- Q614 H-4
- Q615 G-3
- Q616 G-4
- Q617 *G-5
- Q618 *G-5
- Q700 C-2
- Q701 C-2
- Q702 C-2
- Q703 C-1
- Q704 *G-2
- Q705 *H-1
- Q708 *G-1
- Q709 *D-3
- Q710 *D-2

- IC100 D-3
- IC101 D-3
- IC102 F-3
- IC103 E-3
- IC104 E-3
- IC105 *D-3
- IC200 D-6
- IC201 F-5
- IC202 D-5
- IC203 D-4
- IC204 D-6
- IC206 C-5
- IC207 D-5
- IC208 E-5
- IC301 B-5
- IC302 C-7
- IC303 B-6
- IC304 B-6
- IC305 B-7
- IC306 B-6
- IC307 B-6
- IC308 B-7
- IC309 C-7
- IC310 A-6
- IC311 A-6
- IC312 A-6
- IC313 B-6
- IC400 B-3
- IC401 A-2
- IC402 B-2
- IC403 B-2
- IC404 B-2
- IC405 A-2
- IC406 A-2
- IC500 F-8
- IC501 F-7
- IC502 H-8
- IC503 H-7
- IC504 H-8
- IC505 H-7
- IC506 H-8
- IC507 H-7
- IC510 H-7
- IC611 G-3
- IC702 J-3
- IC704 C-2
- IC705 D-2
- IC706 C-2
- IC707 C-2
- IC708 D-2
- IC709 C-2
- IC710 C-3
- IC711 D-7
- IC712 G-2
- IC713 *H-1
- IC714 *C-3
- IC715 *G-2

- TP200 E-5
- TP201 E-5
- TP202 D-4
- TP203 E-3
- TP204 D-7
- TP400 B-2
- TP401 B-2
- TP500 G-7
- TP503 G-8
- TP609 H-6
- TP610 F-5
- TP700 B-7
- TP701 G-7
- TP702 J-3
- TP703 H-4
- TP704 H-4
- TP705 H-5
- TP706 H-6
- TP707 B-3
- TP708 B-2

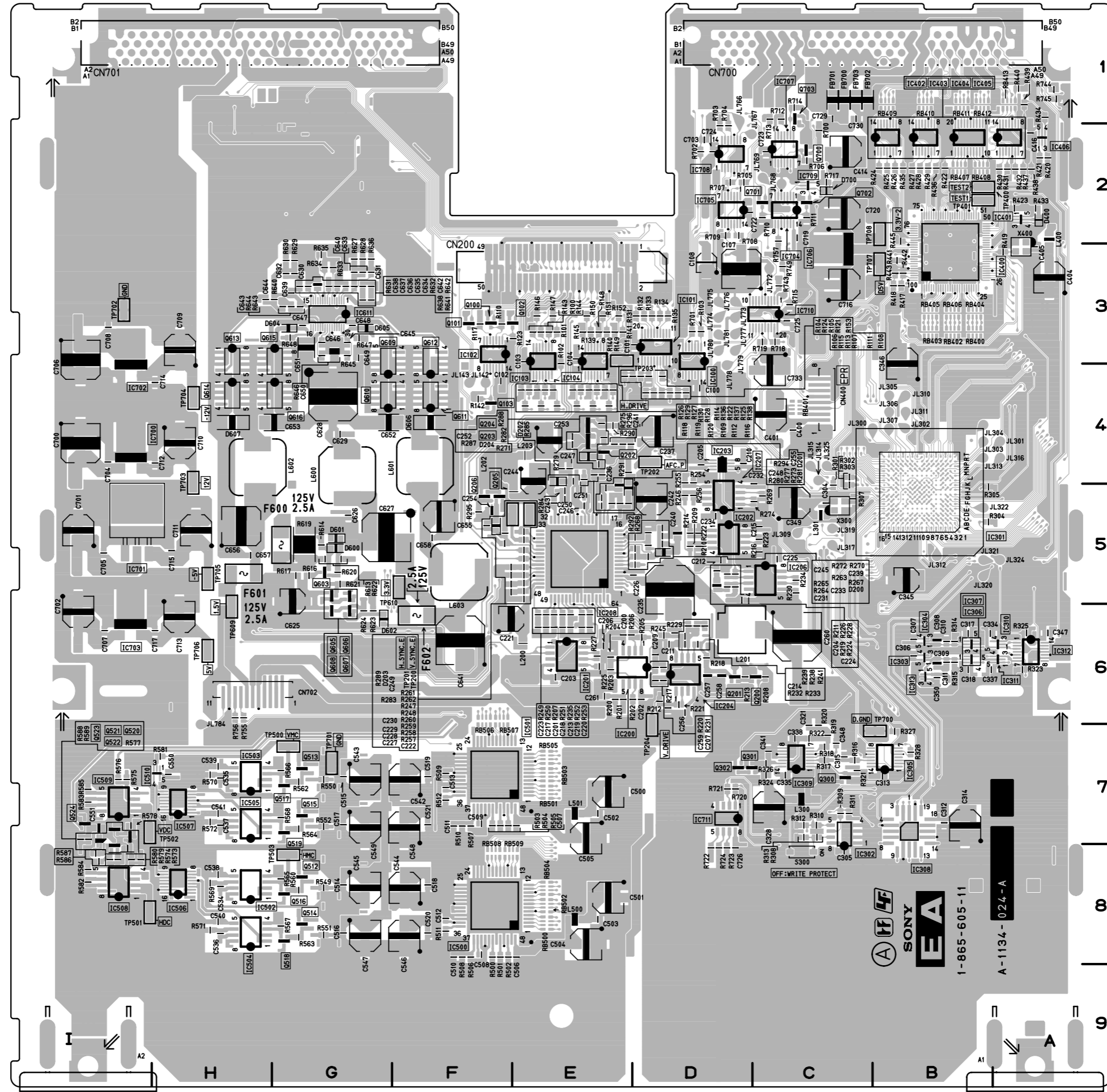

EA - A SIDE -
SUFFIX: -11

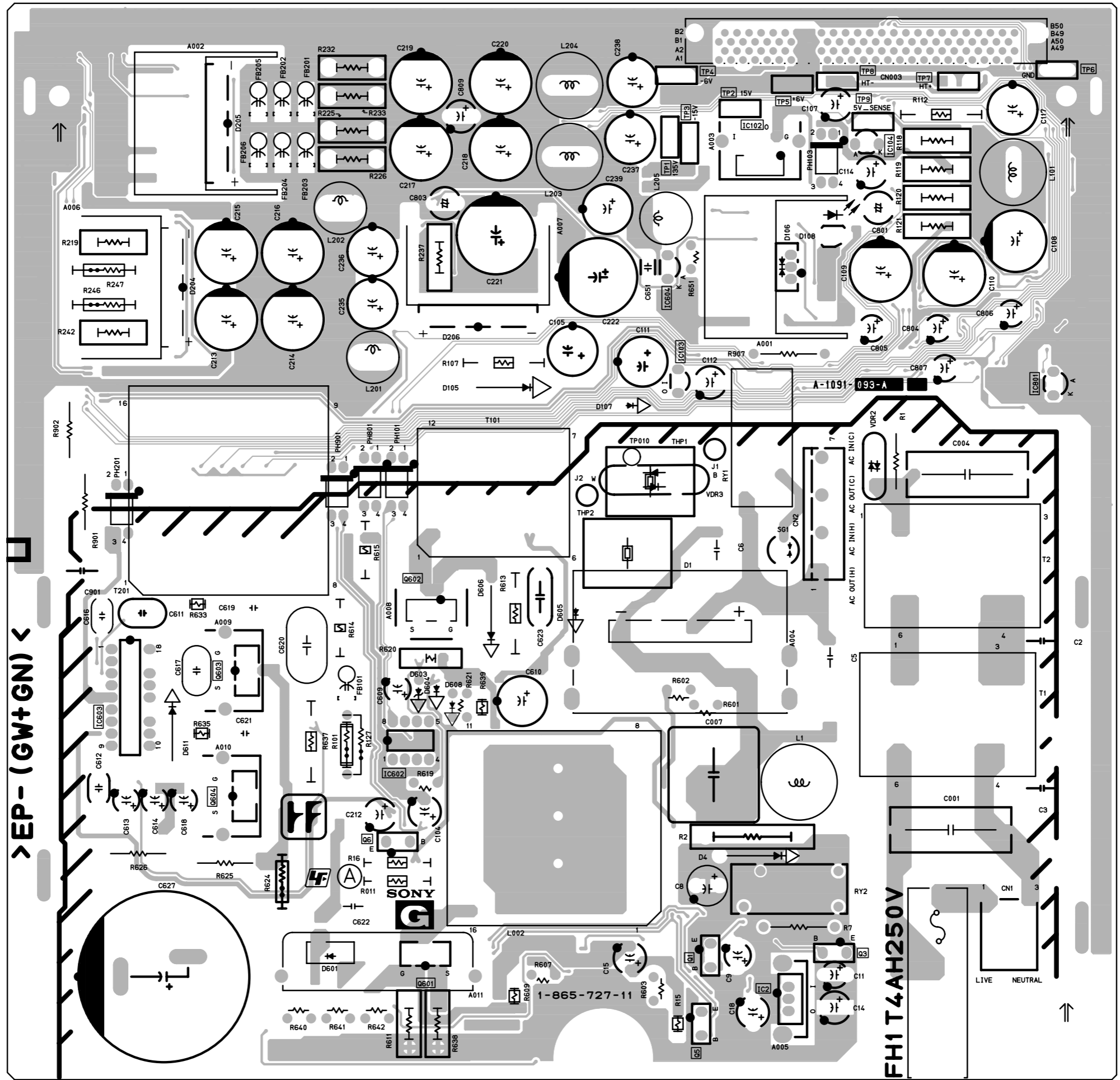

G - A SIDE - SUFFIX: -11

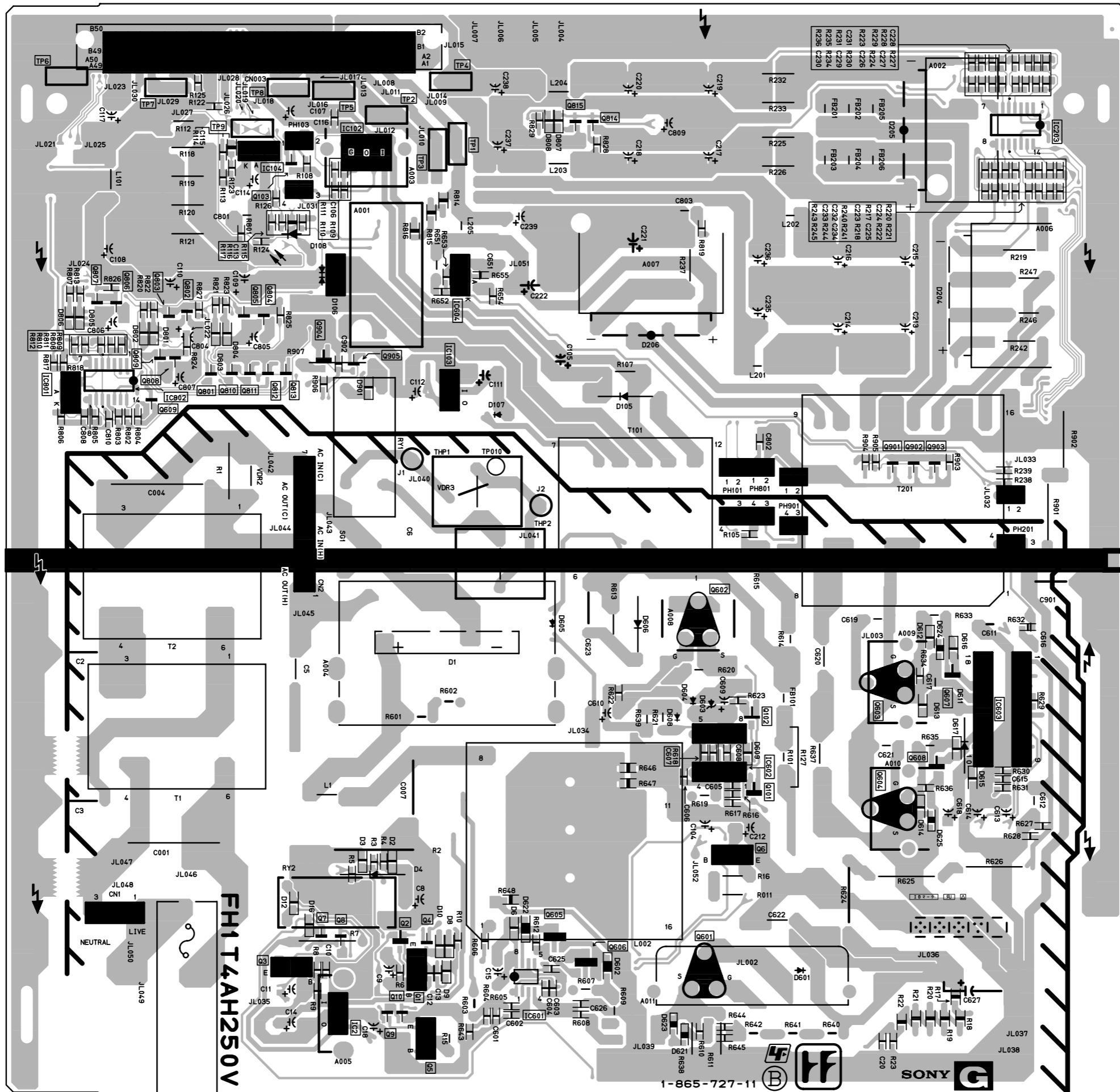

G G

FH1T4AH250V

G -B SIDE-
SUFFIX: -11

HA, HB HA, HB

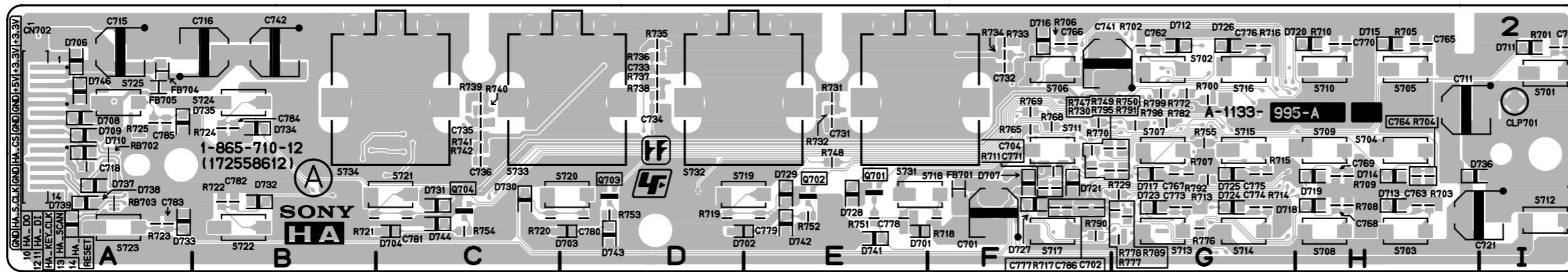

HA - A SIDE-
SUFFIX: -12

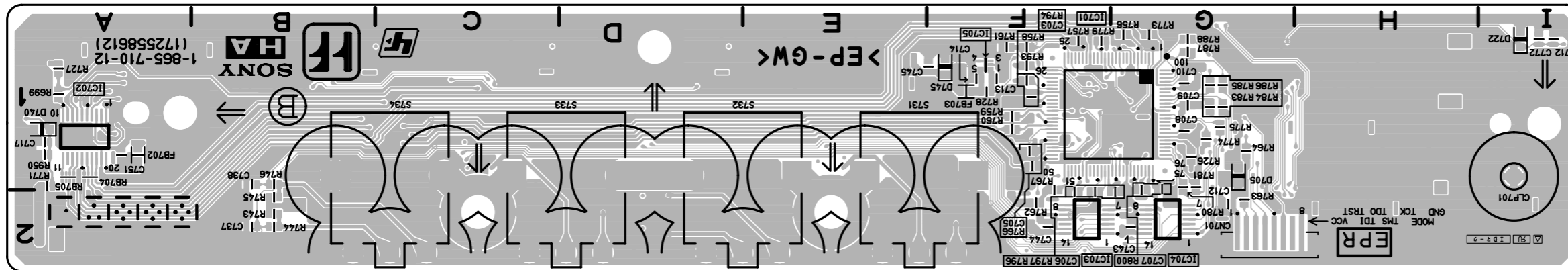

HA - B SIDE-
SUFFIX: -12

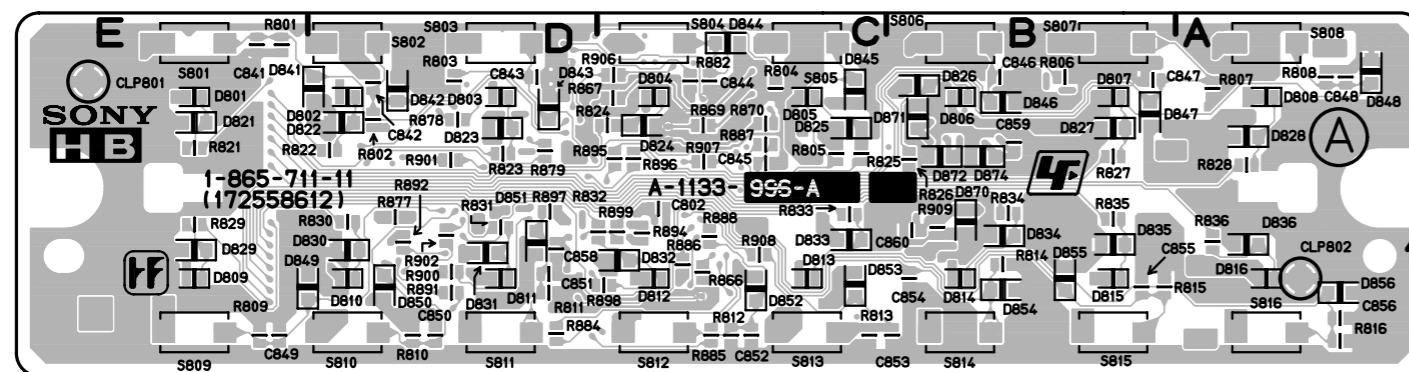

HB - A SIDE-
SUFFIX: -11

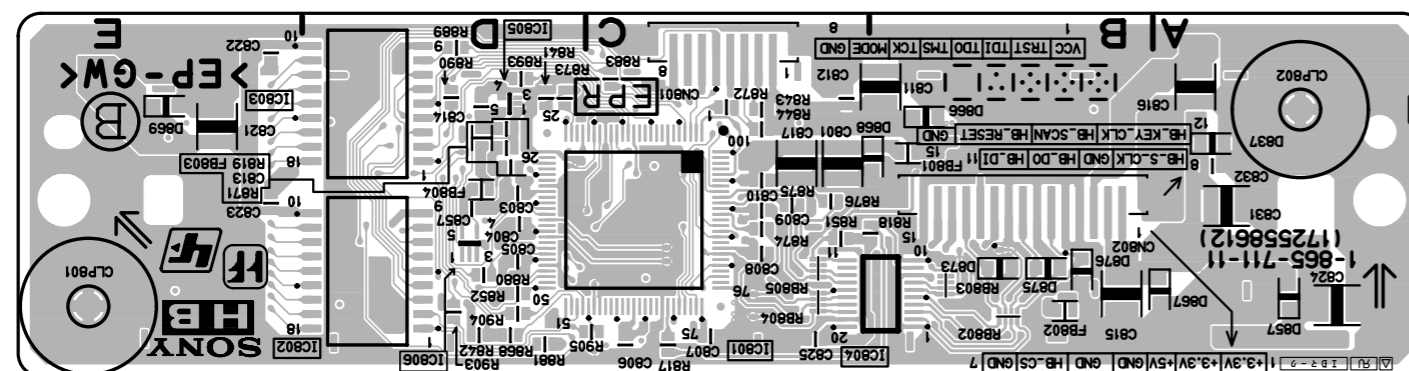

HB - B SIDE-
SUFFIX: -11

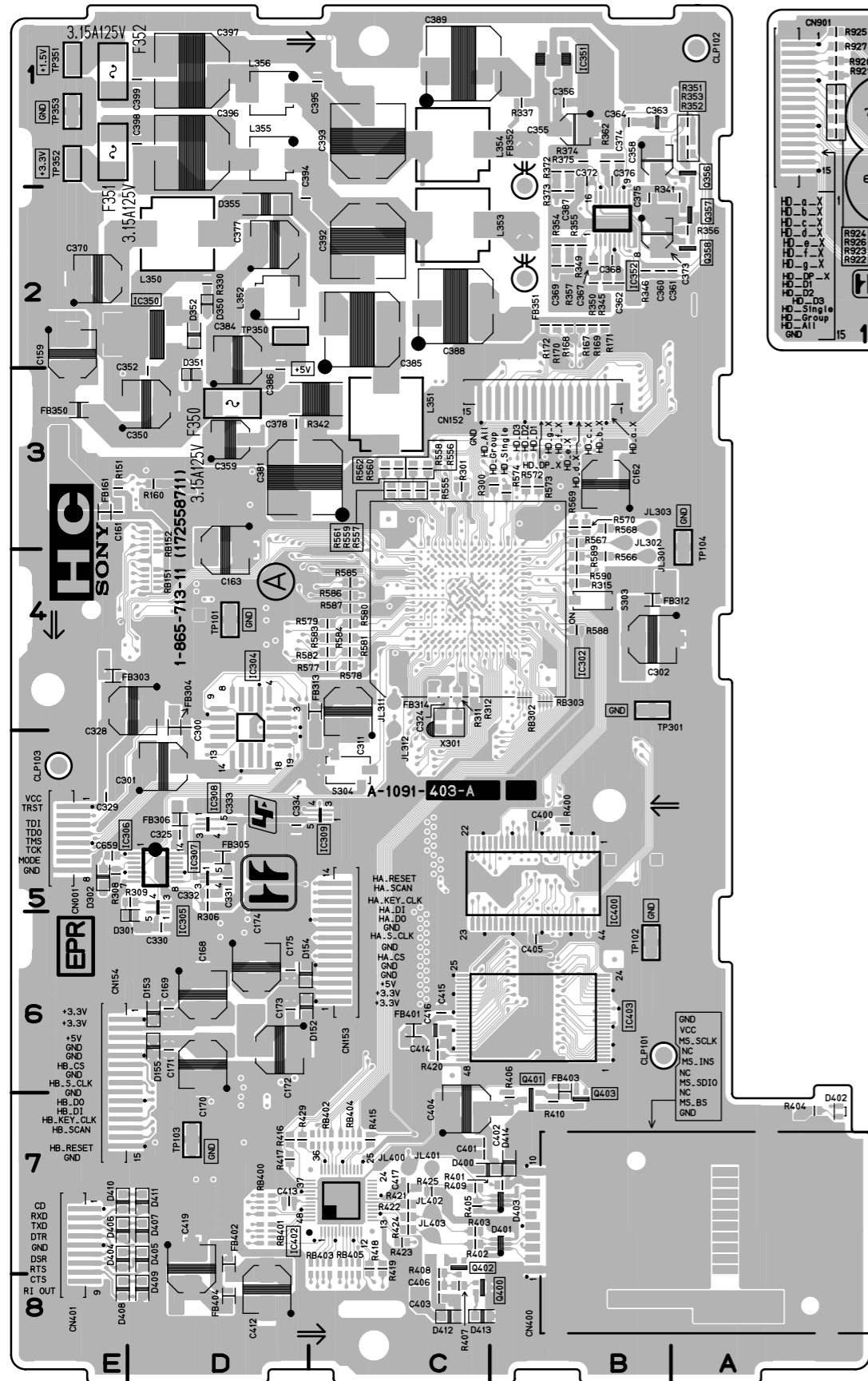

HC - A SIDE-
SUFFIX: -11

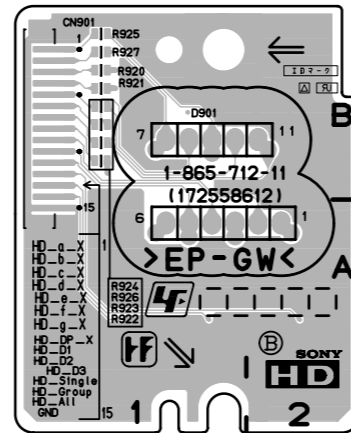

HD - B SIDE-
SUFFIX: -11

HC BOARD
*: B SIDE

- D151 * E-3
- D152 D-6
- D153 D-6
- D154 D-6
- D155 D-6
- D301 D-6
- D302 E-5
- D350 D-2
- D351 D-3
- D352 D-2
- D353 * D-3
- D354 * C-3
- D355 D-2
- D356 * C-2
- D357 * C-1
- D358 * C-2
- D359 * C-1
- D400 B-7
- D401 B-7
- D402 A-7
- D403 B-7
- D404 E-7
- D405 D-7
- D406 E-7
- D407 D-7
- D408 E-8
- D409 D-8
- D410 E-7
- D411 D-7
- D412 C-8
- D413 C-8
- D414 B-7
- IC151 * D-4
- IC152 * D-4
- IC153 * D-4
- IC154 * D-3
- IC156 * D-3
- IC157 * B-3
- IC158 * B-3
- IC159 * D-6
- IC160 * D-7
- IC302 C-4
- IC304 D-4
- IC305 D-5
- IC306 D-5
- IC307 D-5
- IC308 D-5
- IC309 C-5
- IC350 D-2
- IC351 B-1
- IC352 B-2
- IC353 * D-2
- IC354 * C-2
- IC400 B-5
- IC401 * D-7
- IC402 C-7
- IC403 B-6

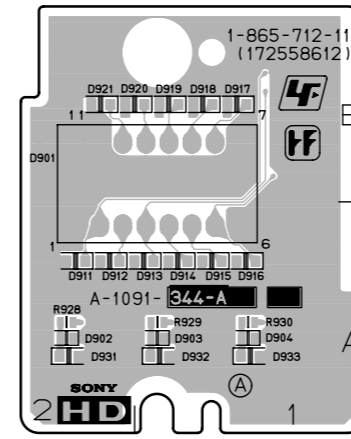

HD - A SIDE-
SUFFIX: -11

- Q350 * D-2
- Q351 * D-2
- Q352 * D-3
- Q353 * D-3
- Q354 * D-3
- Q355 * C-3
- Q356 A-1
- Q357 A-2
- Q358 A-2
- Q359 * D-2
- Q360 * C-2
- Q361 * C-3
- Q362 * C-2
- Q363 * C-2
- Q364 * C-3
- Q365 * C-3
- Q366 * B-2
- Q367 * A-2
- Q368 * A-1
- Q369 * B-1
- Q370 * B-2
- Q371 * A-2
- Q372 * A-1
- Q373 * B-1
- Q374 * B-2
- Q375 * B-1
- Q400 C-8
- Q401 B-7
- Q402 C-7
- Q403 B-7
- TP101 D-4
- TP102 B-6
- TP103 D-7
- TP104 A-3
- TP301 B-4
- TP350 D-2
- TP351 E-1
- TP352 E-1
- TP353 E-1

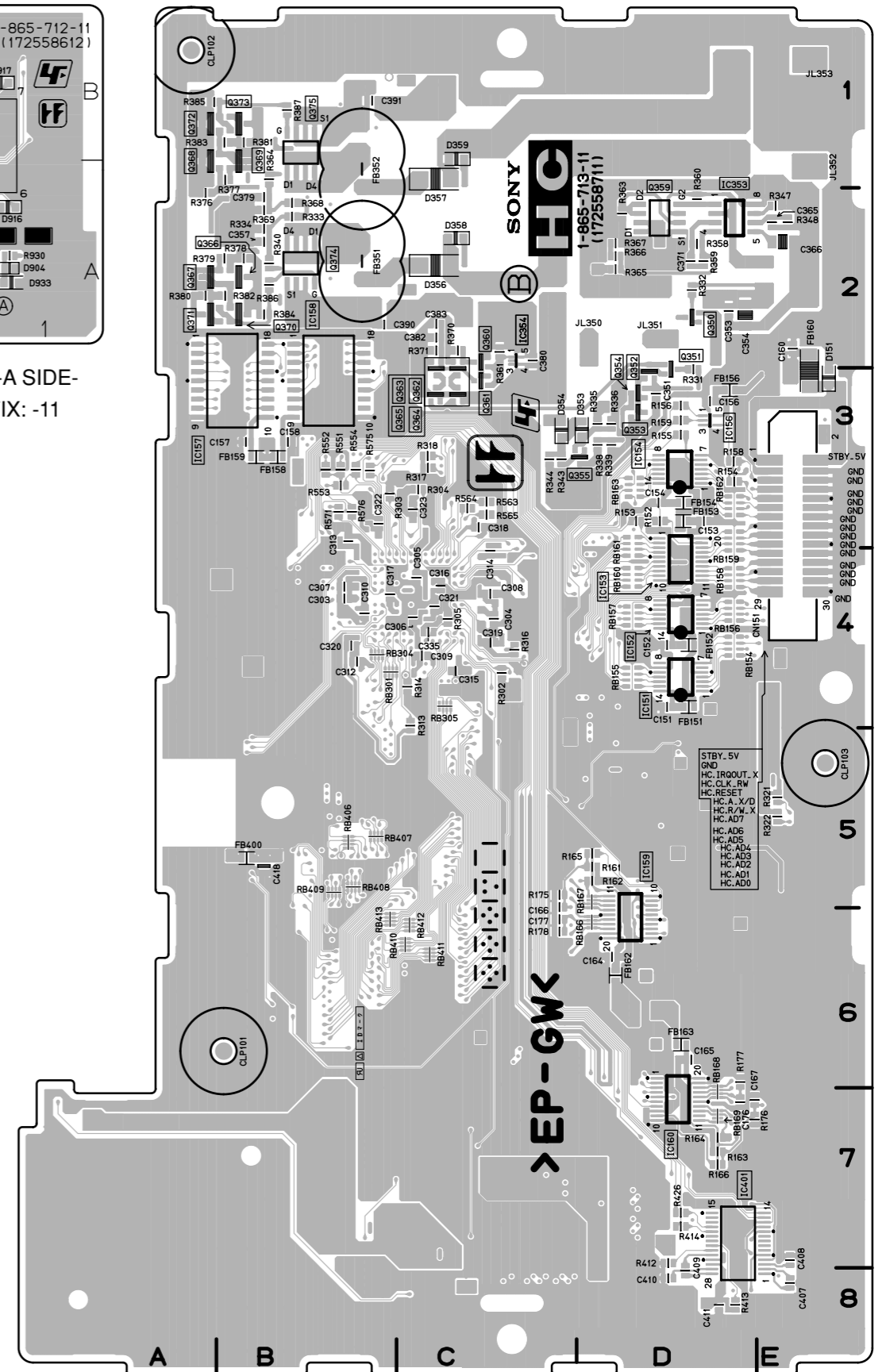

HC - B SIDE-
SUFFIX: -11

PA BOARD

*: B SIDE

- D102 C-4
- D103 C-5
- D104 C-5
- D105 E-4
- D106 D-2
- D108 F-4
- D201 E-5
- D501 B-2
- D502 C-2
- D504 C-2
- D505 E-2
- D506 C-2
- D510 C-2
- D601 A-2
- D603 D-4
- D608 D-4
- D609 C-4
- D651 A-2
- D659 C-4
- D660 C-4

- IC101 C-5
- IC151 A-1
- IC152 B-2
- IC501 B-2
- IC502 C-1
- IC601 C-4

- Q101 C-3
- Q102 C-3
- Q103 C-3
- Q104 C-3
- Q105 C-4
- Q108 F-4
- Q109 G-3
- Q201 D-5
- Q202 G-3
- Q301 G-4
- Q404 B-3
- Q405 B-4
- Q451 B-5
- Q452 A-5
- Q501 B-2
- Q601 C-2
- Q602 C-2
- Q651 C-2
- Q652 C-2

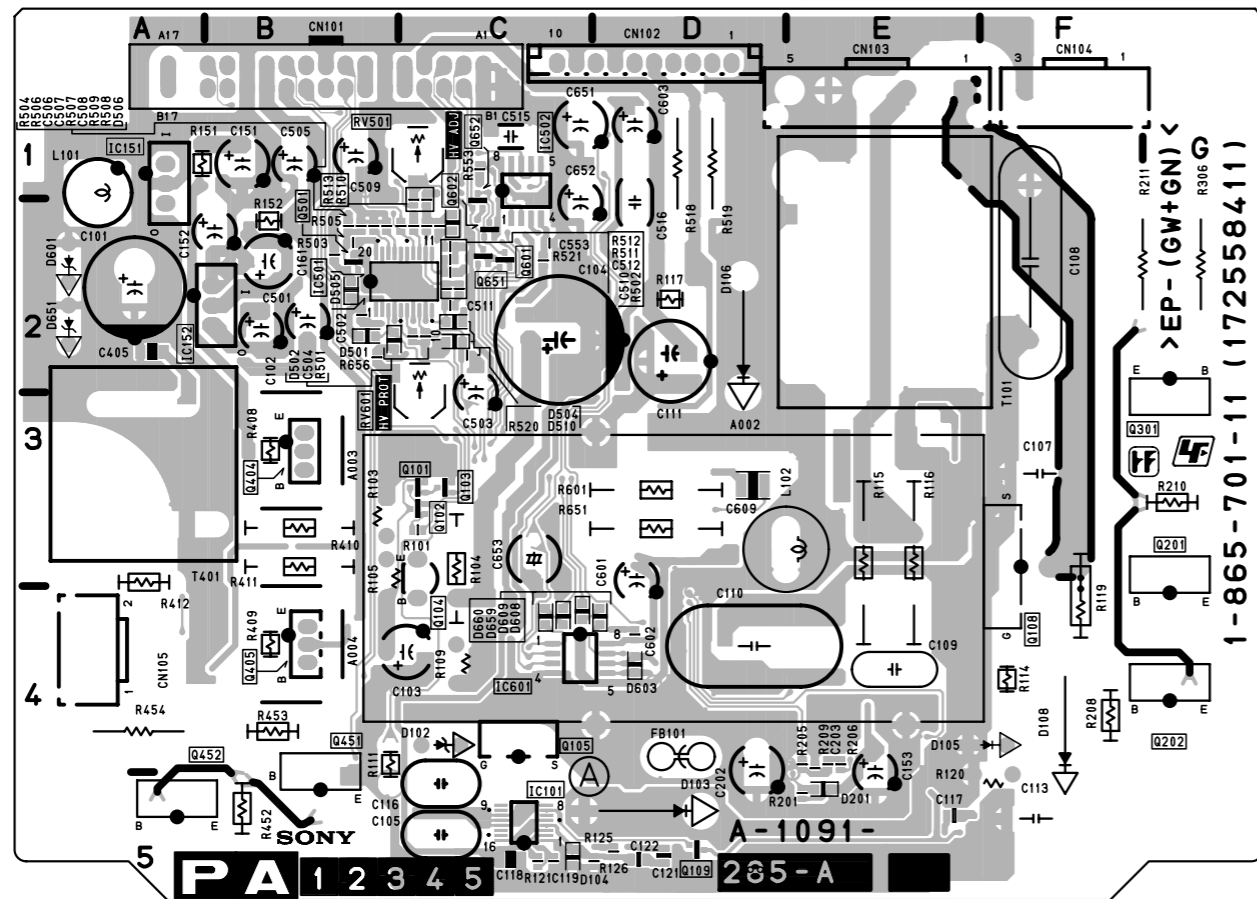

PA - A SIDE-
SUFFIX: -11

PA, PC

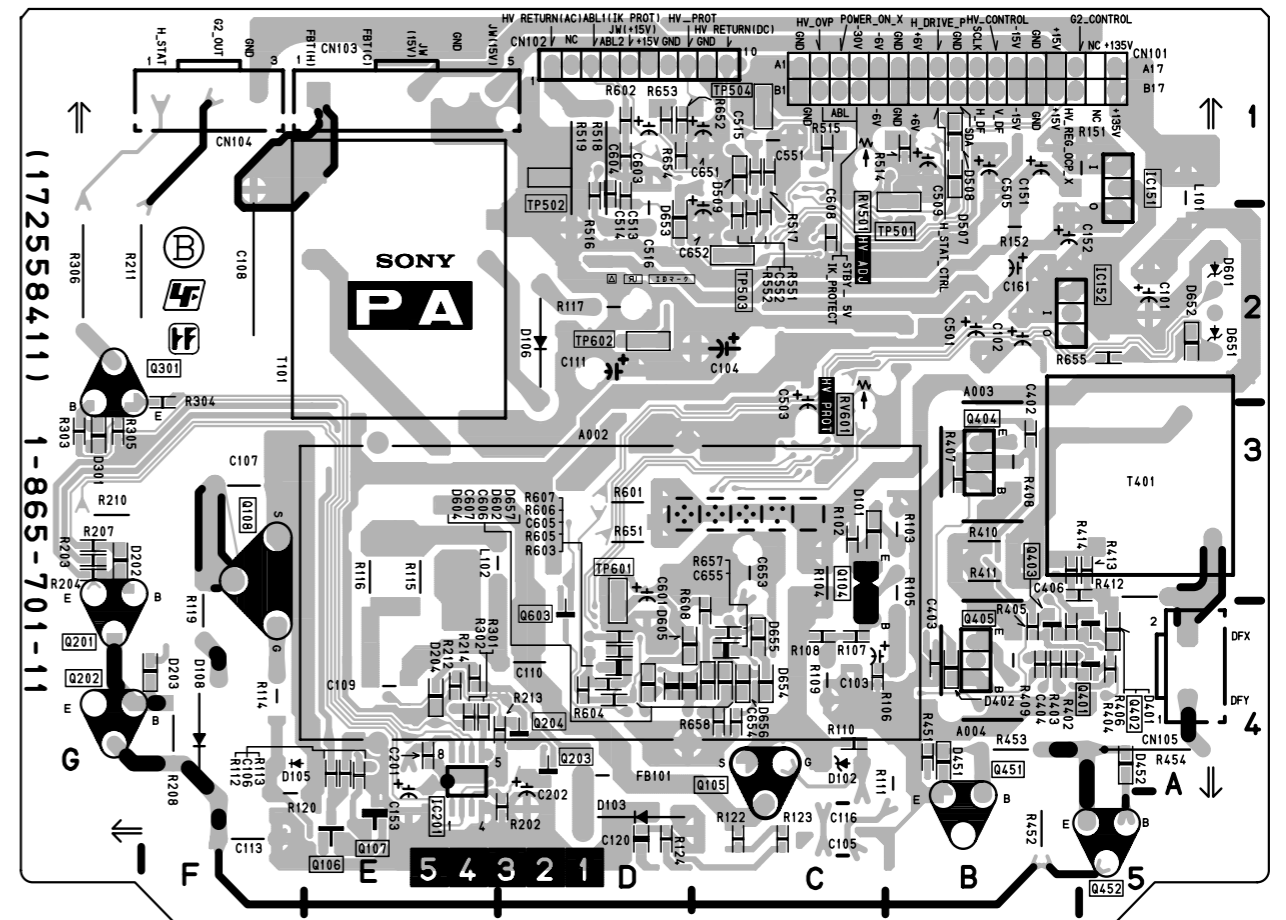

PA - B SIDE-
SUFFIX: -11

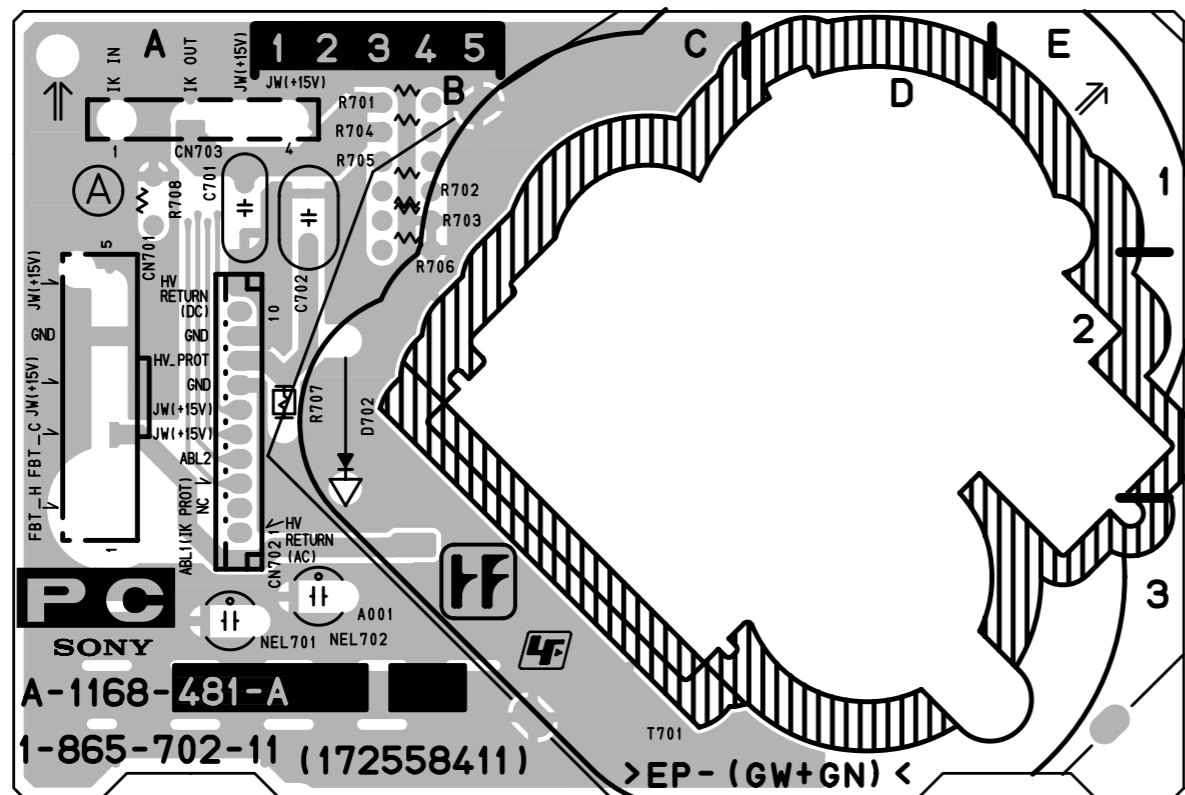

PC - A SIDE-
SUFFIX: -11

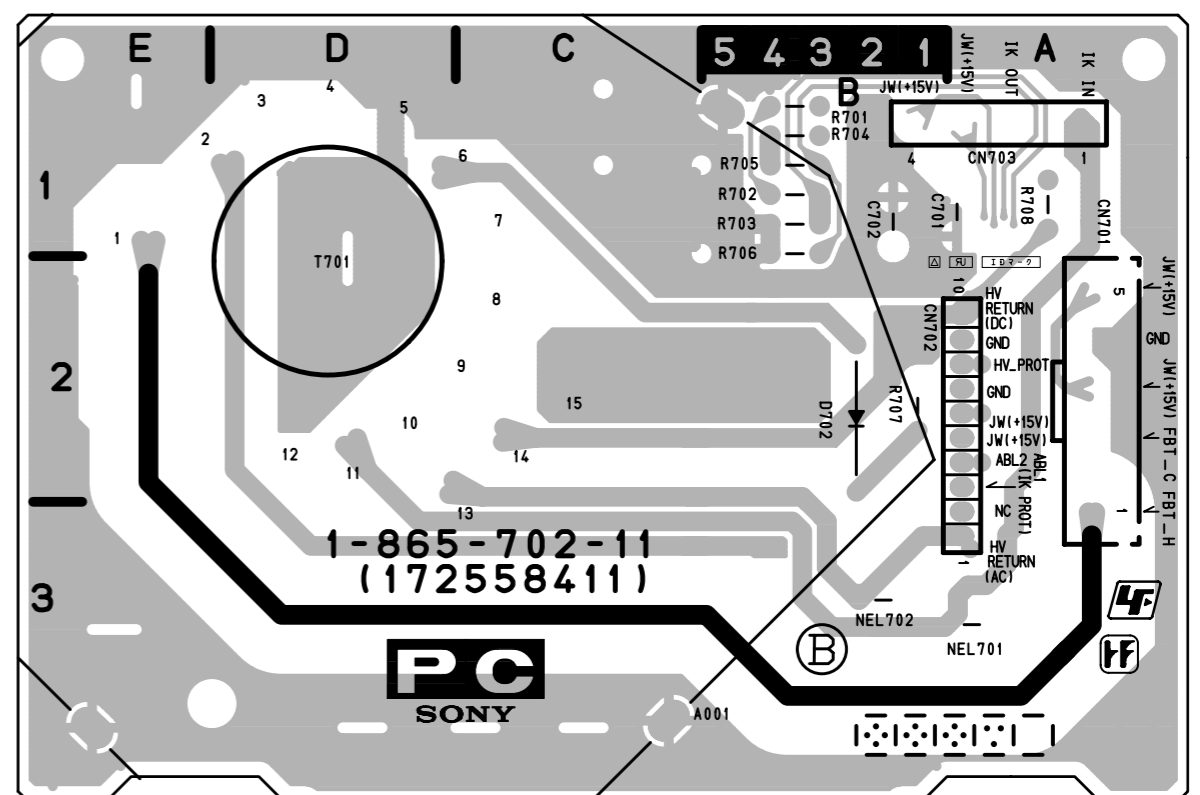

PC - B SIDE-
SUFFIX: -11

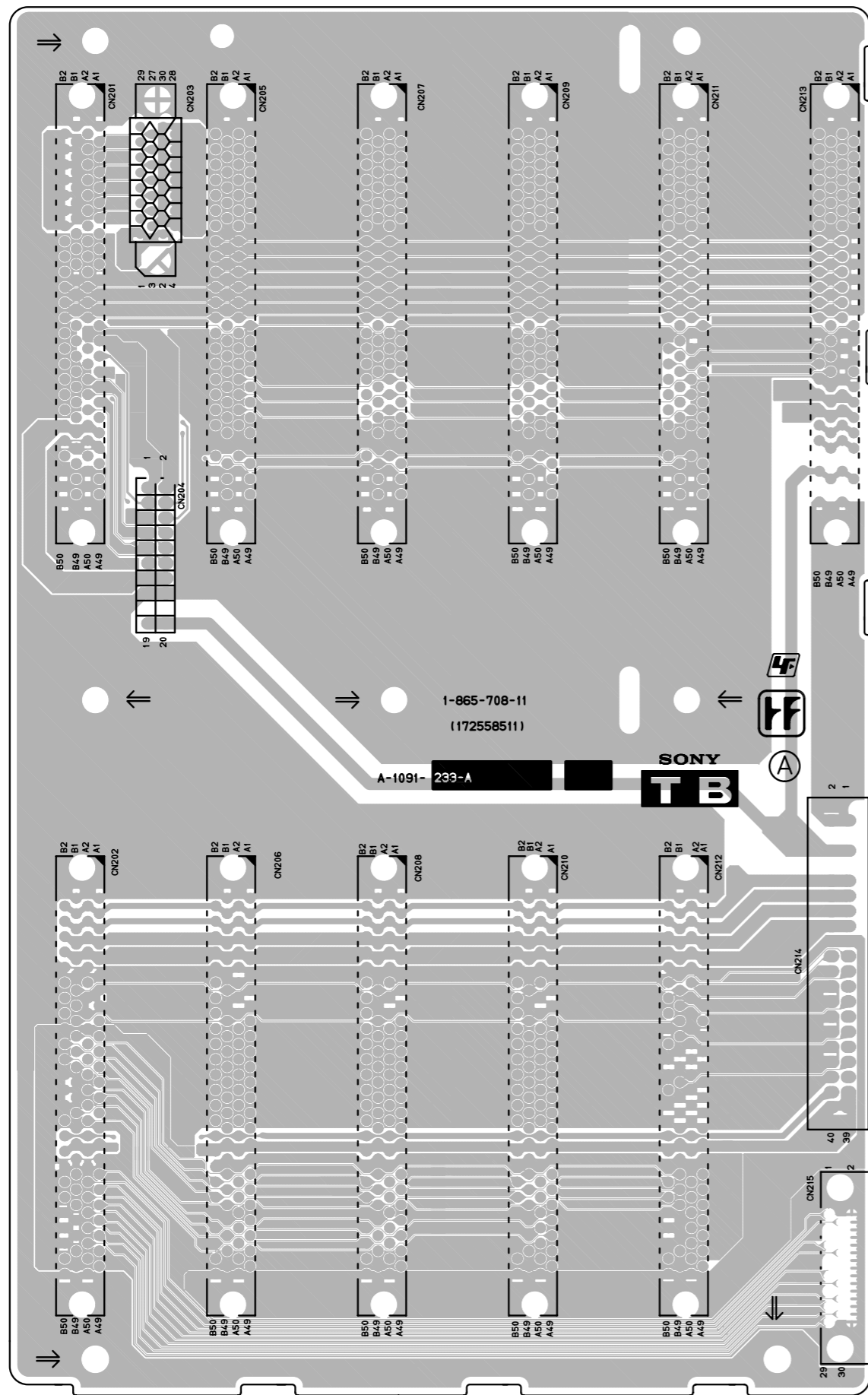

TB - A SIDE-
SUFFIX: -11

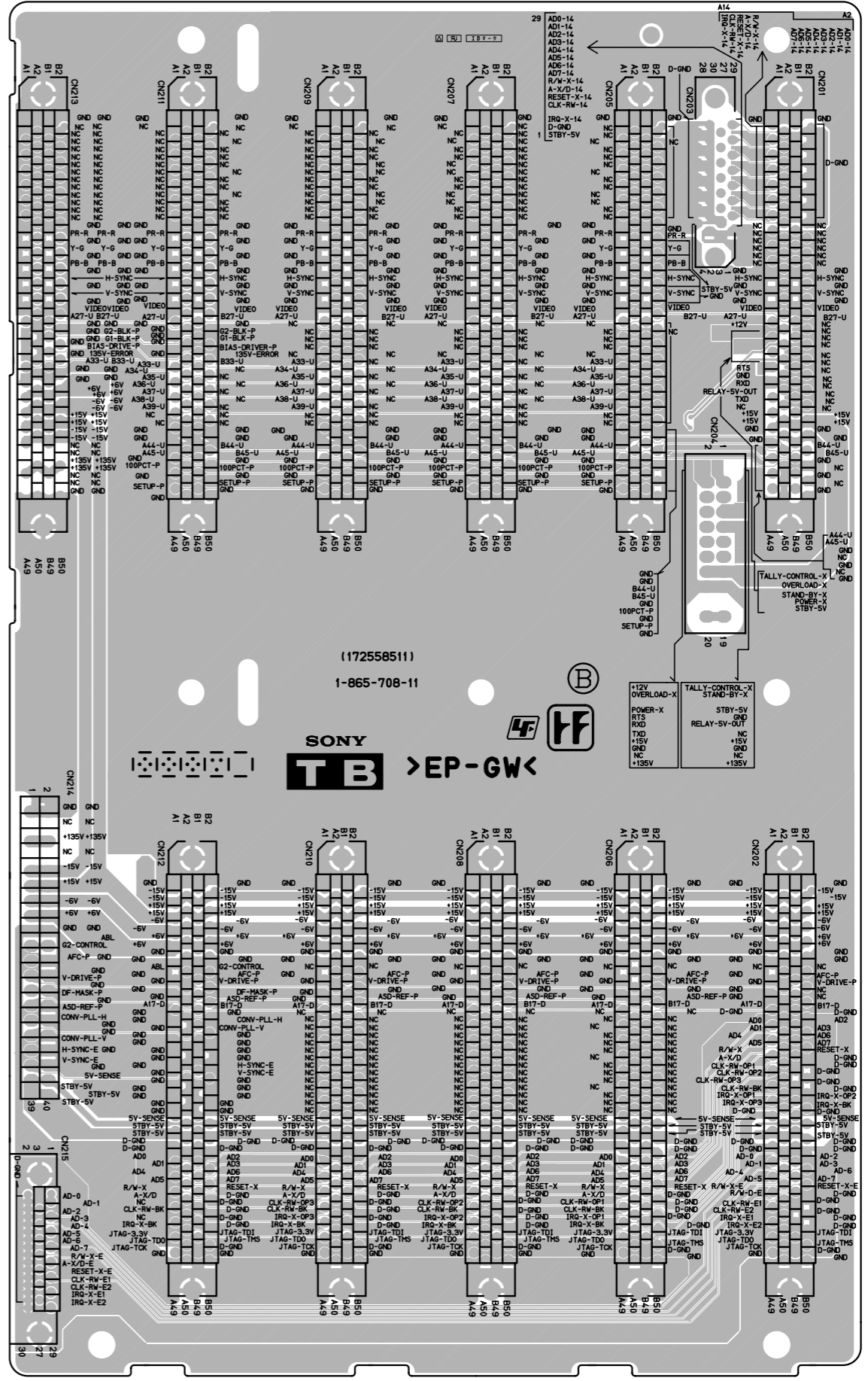

TB - B SIDE-
SUFFIX: -11

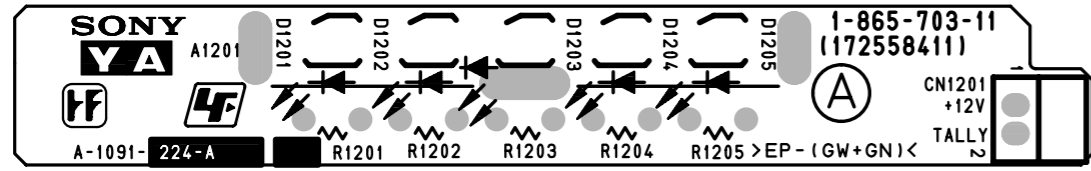

YA -A SIDE-
SUFFIX: -11

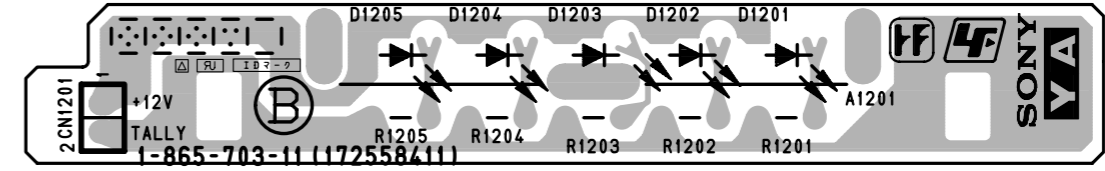

YA -B SIDE-
SUFFIX: -11

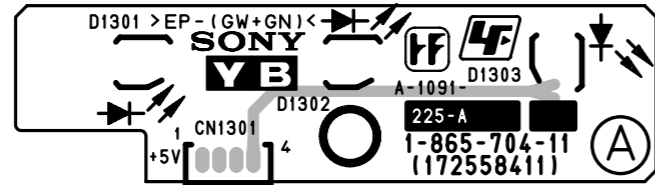

YB -A SIDE-
SUFFIX: -11

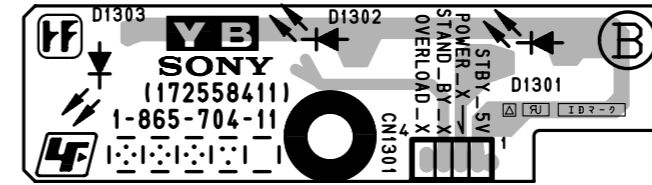

YB -B SIDE-
SUFFIX: -11

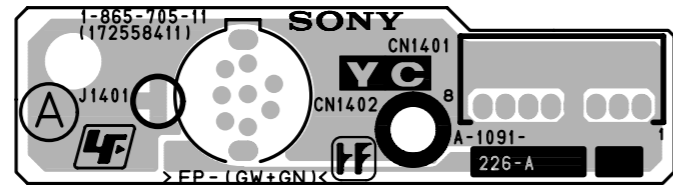

YC -A SIDE-
SUFFIX: -11

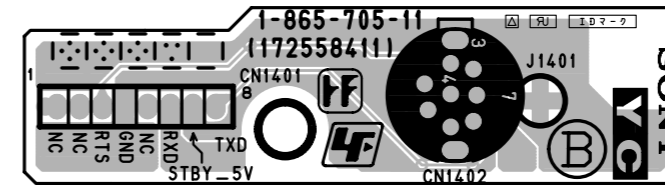

YC -B SIDE-
SUFFIX: -11

SAFETY CHECK-OUT

After correcting the original service problem, perform the following safety checks before releasing the set to the customer :

Check the metal trim, "metallized" knobs, screws, and all other exposed metal parts for AC leakage. Check leakage as described below.

LEAKAGE TEST

The AC leakage from any exposed metal part to earth ground and from all exposed metal parts to any exposed metal part having a return to chassis, must not exceed 3.5 mA. Leakage current can be measured by any one of three methods.

1. A commercial leakage tester, such as the Simpson 229 or RCA WT-540A. Follow the manufacturers' instructions to use these instruments.
2. A battery-operated AC milliammeter. The Data Precision 245 digital multimeter is suitable for this job.
3. Measuring the voltage drop across a resistor by means of a VOM or battery-operated AC voltmeter. The "limit" indication is 5.25 V, so analog meters must have an accurate low-voltage scale. The Simpson 250 and Sanwa SH-63Trd are examples of a passive VOM that is suitable. Nearly all battery operated digital multimeters that have a 20 V AC range are suitable. (See Fig. A)

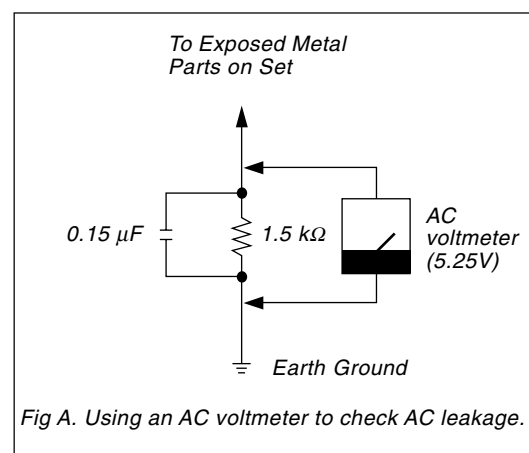

Fig A. Using an AC voltmeter to check AC leakage.

BVM-A14F5M (AE)
BVM-A14F5U (UC)
BVM-A14F5A (AUS) E
9-968-236-01

Sony Corporation

Printed in Japan
2006. 2 16
©2006