

**SONY®**

TRINITRON® COLOR VIDEO MONITOR

**BVM-14E1E/14E1U**

CHASSIS NO. SCC-J32E-A/SCC-H99F-A

**BVM-14E5E/14E5U**

CHASSIS NO. SCC-J32F-A/SCC-H99G-A

**BVM-14F1E/14F1U**

CHASSIS NO. SCC-J32B-A/SCC-H99B-A

**BVM-14F5E/14F5U**

CHASSIS NO. SCC-J32C-A/SCC-H99C-A

**BVM-20E1E/20E1U**

CHASSIS NO. SCC-J32D-A (AEP)/N52B-A (AUS) SCC-H99E-A (U/C)

**BVM-20F1E/20F1U**

CHASSIS NO. SCC-J32A-A (AEP)/N52A-A (AUS) SCC-H99A-A (U/C)

MONITOR CONTROL UNIT  
**BKM-10R**



OPERATION AND MAINTENANCE MANUAL


1st Edition (Revised 3)

Serial No. 2000001 and Higher (ALL MODELS)

**WARNING !!**

AN ISOLATION TRANSFORMER SHOULD BE USED DURING ANY SERVICE TO AVOID POSSIBLE SHOCK HAZARD, BECAUSE OF LIVE CHASSIS. THE CHASSIS OF THIS RECEIVER IS DIRECTLY CONNECTED TO THE AC POWER LINE.


**SAFETY-RELATED COMPONENT WARNING !!**

COMPONENTS IDENTIFIED BY SHADING AND MARK  ON THE SCHEMATIC DIAGRAMS, EXPLODED VIEWS AND IN THE PARTS LIST ARE CRITICAL TO SAFE OPERATION. REPLACE THESE COMPONENTS WITH SONY PARTS WHOSE PART NUMBERS APPEAR AS SHOWN IN THIS MANUAL OR IN SUPPLEMENTS PUBLISHED BY SONY. CIRCUIT ADJUSTMENTS THAT ARE CRITICAL TO SAFE OPERATION ARE IDENTIFIED IN THIS MANUAL. FOLLOW THESE PROCEDURES WHENEVER CRITICAL COMPONENTS ARE REPLACED OR IMPROPER OPERATION IS SUSPECTED.

**ATTENTION!!**

AFIN D'ÉVITER TOUT RISQUE D'ELECTROCUTION PROVENANT D'UN CHÂSSIS SOUS TENSION, UN TRANSFORMATEUR D'ISOLEMENT DOIT ÊTRE UTILISÉ LORS DE TOUT DÉPANNAGE. LE CHÂSSIS DE CE RÉCEPTEUR EST DIRECTEMENT RACCORDÉ À L'ALIMENTATION SECTEUR.

**ATTENTION AUX COMPOSANTS RELATIFS À LA SÉCURITÉ!!**

LES COMPOSANTS IDENTIFIÉS PAR UNE TRAME ET PAR UNE MARQUE  SUR LES SCHÉMAS DE PRINCIPE, LES VUES EXPLOSÉES ET LES LISTES DE PIÈCES SONT D'UNE IMPORTANCE CRITIQUE POUR LA SÉCURITÉ DU FONCTIONNEMENT. NE LES REMPLACER QUE PAR DES COMPOSANTS SONY DONT LE NUMÉRO DE PIÈCE EST INDIQUÉ DANS LE PRÉSENT MANUEL OU DANS DES SUPPLÉMENTS PUBLIÉS PAR SONY. LES RÉGLAGES DE CIRCUIT DONT L'IMPORTANCE EST CRITIQUE POUR LA SÉCURITÉ DU FONCTIONNEMENT SONT IDENTIFIÉS DANS LE PRÉSENT MANUEL. SUIVRE CES PROCÉDURES LORS DE CHAQUE REMPLACEMENT DE COMPOSANTS CRITIQUES, OU LORSQU'UN MAUVAIS FONCTIONNEMENT EST SUSPECTÉ.



# TABLE OF CONTENTS

## 1. GENERAL

• BVM-14E1E/14E1U/14E5E/14E5U/14F1E/14F1U/14F5E/14F5U/20E1U/20F1E/20F1U	
Overview .....	1-2
Features .....	1-2
Options .....	1-2
Connector panel configuration .....	1-3
Location and Function of Parts .....	1-4
Front Panel .....	1-4
Rear Panel .....	1-7
Guidance for Basic Monitor Operations .....	1-8
Basic Menu Operations .....	1-9
Displaying the Menus .....	1-9
ADDRESS Menu .....	1-9
Selecting the Menu .....	1-9
Changing the Settings .....	1-10
Preset Adjustment of the Picture Level Control Knobs —	
CONTROL PRESET ADJ Menu .....	1-12
Structure and Usage of the CONTROL PRESET ADJ Menu .....	1-12
Adjusting the Color Temperature —	
COLOR TEMP ADJ Menu .....	1-13
Structure and Usage of the COLOR TEMP ADJ Menu .....	1-13
Setting the Input Configuration —	
INPUT CONFIGURATION Menu .....	1-15
Structure and Usage of the INPUT CONFIGURATION Menu .....	1-16
Assigning the Remote Control Functions —	
REMOTE Menu .....	1-18
Structure and Usage of the REMOTE Menu .....	1-18
Setting the Password PASSWORD Menu .....	1-19
Structure and Usage of the PASSWORD Menu .....	1-19
Setting the Channel Selection Method and Power-Up Conditions — SYSTEM CONFIGURATION Menu .....	1-20
Structure and Usage of the SYSTEM CONFIGURATION Menu .....	1-21
Setting the Screen Display — ON SCREEN SET Menu ..	1-21
Structure and Usage of the ON SCREEN SET Menu ....	1-22
Convergence Adjustments — ALIGNMENT Menu .....	1-24
Structure and Usage of the ALIGNMENT Menu .....	1-24
Monitor Memory Card Data Operations —	
MEMORY CARD Menu .....	1-25
Structure and Usage of the MEMORY CARD Menu ....	1-25
Monitor-to-Monitor Data Copy — COPY Menu .....	1-26
Structure and Usage of the COPY Menu .....	1-26
Displaying Information About the Monitor —	
STATUS Menu .....	1-26
Structure and Usage of the STATUS Menu .....	1-26
Selecting the Monitor to Control — ADDRESS Menu ....	1-27
Structure and Usage of the ADDRESS Menu .....	1-27
Specifications .....	1-28

• BKM-30E20	
Overview .....	1-30
Components .....	1-30
Assembly .....	1-30
• BKM-30E14	
Overview .....	1-33
Components .....	1-33
Assembly .....	1-33
• BKM-31E14	
Overview .....	1-35
Components .....	1-35
Assembly .....	1-35
• BKM-32H	
Overview .....	1-37
Components .....	1-37
Assembly .....	1-37
• BKM-10R	
Overview .....	1-41
Location and Function of Parts .....	1-41
Inserting and Ejecting the Monitor Memory Card .....	1-43
Mounting the Unit in a Rack .....	1-43
Specifications .....	1-44

## 2. DISASSEMBLY

2-1-1. Cabinet Removal (BVM-14E1E/14E1U/14E5E/14E5U/14F1E/14F1U/14F5E/14F5U) .....	2-1
2-1-2. Cabinet Removal (BVM-20E1E/20E1U/20F1E/20F1U) .....	2-1
2-2-1. PA Board Removal (BVM-14E1E/14E1U/14E5E/14E5U/14F1E/14F1U/14F5E/14F5U) .....	2-2
2-2-2. PA Board Removal (BVM-20E1E/20E1U/20F1E/20F1U) .....	2-2
2-3-1. PC Board Removal (BVM-14E1E/14E1U/14E5E/14E5U/14F1E/14F1U/14F5E/14F5U) .....	2-3
2-3-2. PC Board Removal (BVM-20E1E/20E1U/20F1E/20F1U) .....	2-3
2-4. E and G Boards Removal and Check .....	2-4
2-5. BC and BK Boards Removal and Check .....	2-4
2-6-1. Slot Card Assy Removal (BVM-14E1E/14E1U/14E5E/14E5U/14F1E/14F1U/14F5E/14F5U) .....	2-5
2-6-2. Slot Card Assy Removal (BVM-20E1E/20E1U/20F1E/20F1U) .....	2-5
2-7. TA and TB Boards Removal .....	2-6
2-8-1-1. YA, YB and YC Boards Removal (BVM-14E1E/14E1U/14F1E/14F1U) .....	2-6
2-8-1-2. BEZEL ASSY Removal (BVM-14E5E/14E5U/14F1E/14F1U) .....	2-7
2-8-1-3. HA, HB, YA, YB and YC Boards Removal (BVM-14E5E/14E5U/14F5E/14F5U) .....	2-7
2-8-2. YA, YB and YC Boards Removal (BVM-20E1E/20E1U/20F1E/20F1U) .....	2-8
2-9-1. Picture Tube Removal (BVM-14E1E/14E1U/14E5E/14E5U/14F1E/14F1U/14F5E/14F5U) .....	2-8
2-9-2. Picture Tube Removal (BVM-20E1E/20E1U/20F1E/20F1U) .....	2-9
2-10. Upper Cover Removal (BKM-10R) .....	2-10

2-11. HA and HB Boards Removal (BKM-10R) .....	2-10
2-12. HC Board Removal (BKM-10R) .....	2-11

### 3. CIRCUIT DESCRIPTIONS

3-1. BK Board Descriptions .....	3-1
1-1. BK Select Switch .....	3-1
1-2. Clamp Circuit (1) .....	3-1
1-3. W B INSERT Pulse Insertion Circuit .....	3-1
1-4. Chroma Level Adjustment Circuit .....	3-1
1-5. Matrix Circuit .....	3-1
1-6. RGB Switch .....	3-1
1-7. Clamp Circuit (2) .....	3-1
1-8. Half Blanking Switch .....	3-1
1-9. 100 IRE Pulse, SET UP Pulse Insertion Circuit ....	3-1
1-10. Blue-Only Switch .....	3-1
1-11. Contrast, Bright Adjustment Circuit .....	3-1
1-12. Pulse Insertion Circuit .....	3-1
1-13. Drive Control Amplifier .....	3-1
1-14. Clamp Circuit (3) .....	3-1
1-15. Cut-Off Switch .....	3-1
1-16. VIDEO OUT Amplifier .....	3-1
1-17. G2 Control .....	3-1
2. ABL, Overload Detection .....	3-1
3. Control Circuit .....	3-1
BK Board Block Diagram (1) .....	3-2
BK Board Block Diagram (2) .....	3-4
3-2. BC Board Descriptions .....	3-5
1. Serial Communication with Boards .....	3-5
2. Internal Signal Generation .....	3-5
3. VITC Reading .....	3-5
4. Character Generator .....	3-5
5. Parallel Remote Control .....	3-5
6. ISR Terminal .....	3-5
7. Serial Remote Terminal .....	3-5
8. Communication with Control Block (HC Board) ..	3-5
BC Board Block Diagram .....	3-6
3-3. E Board Descriptions .....	3-8
E Board Block Diagram .....	3-8
1. Horizontal System .....	3-9
1-1. H DELAY Circuit .....	3-9
1-2. AFC Circuit .....	3-9
1-3. Horizontal Deflection Circuit .....	3-9
1-4. H Center Circuit .....	3-9
1-5. Landing Circuit .....	3-9
1-6. NTC Drive Circuit .....	3-9
1-7. H Linearity Circuit .....	3-9
1-8. Rotation Circuit (20-Inch Model) .....	3-9
1-9. H Convergence Circuit (20-Inch Model) .....	3-9
2. Vertical System .....	3-9
2-1. V Counter .....	3-9
2-2. V.OSC Circuit .....	3-9
2-3. Vertical Deflection Circuit .....	3-9
3. Protection Circuit .....	3-10
3-1. H.STOP, V.STOP Detection Circuit .....	3-10
3-2. Excessive Current Protection Circuit for Horizontal Deflection Circuit Power Supply .....	3-10
4. Control Circuit .....	3-10

3-4. D Board Descriptions .....	3-10
1-1. Signal Generator (IC105) .....	3-10
1-2. DEFLECTION Generator .....	3-10
1-3. H. CONVER Generator .....	3-10
1-4. D/A Converter .....	3-10
1-5. NTC Signal Generation .....	3-10
1-6. H.CONV. SIDE Signal Generation .....	3-10
1-7. H.LIN Signal Generation .....	3-10
1-8. D.F.X. Signal, D.F.Y. Signal Generation .....	3-10
D Board Block Diagram .....	3-11
3-5. PA Board Descriptions .....	3-12
1-1. High Voltage Regulator Circuit .....	3-12
1-2. High Voltage Protector Circuit .....	3-12
1-3. High Voltage Current Protector, ABL Circuit .....	3-12
1-4. Screen (G2) Voltage Regulator .....	3-12
1-5. DF Drive Circuit .....	3-12
PA, PC Board Block Diagram .....	3-13
3-6. Power Supply Circuit Descriptions (G, GA, GB and GC Board) .....	3-14
1. RCC Switching Regulator (IC4 and T5) .....	3-14
2. PFC Switching Regulator .....	3-14
3. PFC OVP Circuit .....	3-14
4. Half Bridge Switching Regulator (Q6, Q7, T4, GA Board IC101, IC102) .....	3-14
5. Power Supply Control .....	3-14
6. PFC Failure Detection Circuit .....	3-14
7. OVP (Over voltage protection), OCP (Over current protection) Circuits (GB Board) .....	3-14
8. SHUT DOWN Circuit (Q301 to Q312 of GB Board) .....	3-14
9. Encoder (GB Board) .....	3-14
10. CRT Protection .....	3-14
G, GA, GB, GC Board Block Diagram .....	3-14
3-7. Control Unit Descriptions (BVM-14F5U/14F5E, BKM-10R) .....	3-16
1. Key Scan, LED Lighting .....	3-16
2. Memory Card .....	3-16
HA Board Block Diagram .....	3-16
HB Board Block Diagram .....	3-16
HC Board Block Diagram .....	3-16

### 4. ELECTRICAL ADJUSTMENTS

4-1. Basic Adjustments in Replacement of CRT .....	4-1
4-2. Safety Related Adjustments .....	4-12
4-3. Electrical Adjustments .....	4-16
1. E Board Adjustments .....	4-16
2. BK Board Adjustments .....	4-18
3. BC Board Adjustments .....	4-25

## 5. DIAGRAMS

5-1. Overall Block Diagram .....	5-2
5-2. Frame Schematic Diagram (1) .....	5-4
Frame Schematic Diagram (2) .....	5-6
5-3. Circuit Boards Location .....	5-8
5-4. Printed Wiring Boards and Schematic Diagrams ...	5-8
TA, TB boards (BVM-14E5E/14E5U/14F5E/14F5U/ 20E1E/20E1U/20F1E/20F1U) .....	5-9
TA, TB boards (BVM-14E1E/14E1U/14F1E/14F1U) .....	5-13
BK board .....	5-16
BC board .....	5-32
E board .....	5-40
D board .....	5-47
PA, PC, C boards .....	5-50
YA, YB, YC boards .....	5-53
HD board (BVM-14E1E/14E1U/14F1E/14F1U/20E1E/ 20E1U/20F1E/20F1U, BKM-10R) .....	5-53
G board .....	5-55
GA, GB, GC boards .....	5-58
HA board (BVM-14E5E/14E5U/14F5E/ 14F5U, BKM-10R) .....	5-61
HB board (BVM-14E5E/14E5U/14F5E/ 14F5U, BKM-10R) .....	5-63
HC board (BVM-14E5E/14E5U/14F5E/ 14F5U, BKM-10R) .....	5-65
5-5. Semiconductors .....	5-69

## 6. EXPLODED VIEWS

6-1. Cover (BVM-14E1E/14E1U/14E5E/14E5U/14F1E/ 14F1U/14F5E/14F5U) .....	6-1
6-2. Chassis (BVM-14E1E/14E1U/14E5E/14E5U/14F1E/ 14F1U/14F5E/14F5U) .....	6-2
6-3. Picture Tube (BVM-14E1E/14E1U/14E5E/14E5U/ 14F1E/14F1U/14F5E/14F5U) .....	6-3
6-4. Cover (BVM-20E1E/20E1U/20F1E/20F1U) .....	6-4
6-5. Chassis (BVM-20E1E/20E1U/20F1E/20F1U) .....	6-5
6-6. Picture Tube (BVM-20E1E/20E1U/20F1E/20F1U)	6-6
6-7. Control (BKM-10R) .....	6-7

## 7. ELECTRICAL PARTS LIST .....

7-1



## WARNING

To prevent fire or shock hazard, do not expose the unit to rain or moisture.

To avoid electrical shock, do not open the cabinet. Refer servicing to qualified personnel only.



This symbol is intended to alert the user to the presence of important operating and maintenance (servicing) instructions in the literature accompanying the appliance.

## AVERTISSEMENT

Afin d'éviter tout risque d'incendie ou d'électrocution, ne pas exposer cet appareil à la pluie ou à l'humidité.

Afin d'écarter tout risque d'électrocution, garder le coffret fermé. Ne confier l'entretien de l'appareil qu'à un personnel qualifié.

## WARNUNG

Um Feuergefahr und die Gefahr eines elektrischen Schlages zu vermeiden, darf das Gerät weder Regen noch Feuchtigkeit ausgesetzt werden.

Um einen elektrischen Schlag zu vermeiden, darf das Gehäuse nicht geöffnet werden. Überlassen Sie Wartungsarbeiten stets nur einem Fachmann.

## ADVERTENCIA

Para evitar incendios o el riesgo de electrocución, no exponga la unidad a la lluvia ni a la humedad.

Para evitar descargas eléctricas, no abra la unidad. En caso de avería, solicite los servicios de personal cualificado.

## ATTENZIONE

Per evitare incendi o cortocircuiti, l'apparecchio non deve essere esposto alla pioggia o all'umidità.

Per evitare scosse elettriche, non aprite l'apparecchio. Per le riparazioni rivolgetevi solo a personale qualificato.

## CAUTION:

Danger of explosion if battery is incorrectly replaced. Replace only with the same or equivalent type recommended by the manufacturer. Discard used batteries according to the manufacturer's instructions.

## ATTENTION

Il y a un risque d'explosion si la pile est mal insérée. Remplacer la pile uniquement par une pile de même type ou de type équivalent recommandé par le fabricant. Jeter les piles usées conformément aux instructions du fabricant.

## VORSICHT:

Es besteht Explosionsgefahr, wenn die Batterie inkorrekt eingelegt wird.

Es darf nur eine identische oder eine vom Hersteller empfohlene Batterie des gleichen Typs eingesetzt werden. Entladene Batterien sind nach den Anweisungen des Herstellers zu entsorgen.

## PRECAUCION

Peligro de explosión en caso de haberse instalado incorrectamente la batería. Cambie sólo por una del mismo tipo o especificaciones equivalentes, de entre las recomendadas por el fabricante. Las baterías viejas se deben eliminar siguiendo las instrucciones del fabricante.

## ATTENZIONE:

Pericolo di esplosione se la pila viene sostituita scorrettamente. Sostituirla solo con un'altra uguale o di un tipo equivalente consigliato dal fabbricante. Gettare via le pile usate secondo le istruzioni del fabbricante.

## Note

The socket-outlet should be installed near the equipment and be easily accessible.

## Remarque

La prise doit être près de l'appareil et facile d'accès.

## Hinweis

Zur Trennung vom Netz ist der Netzstecker aus der Steckdose zu ziehen, welche sich in der Nähe des Gerätes befinden muß und leicht zugänglich sein soll.

## Nota

La toma mural debe estar instalada cerca del equipo y debe accederse a ésta con facilidad.

## Nota

La presa di corrente deve essere situata vicino all'apparecchio e deve essere facilmente accessibile.

WARNING: THIS WARNING IS APPLICABLE FOR USA ONLY.

If used in USA, use the UL LISTED power cord specified below. DO NOT USE ANY OTHER POWER CORD.

Plug Cap	Parallel blade with ground pin (NEMA 5-15P Configuration)
Cord	Type SJT, three 16 or 18 AWG wires
Length	Less than 2.5 m (8 ft 3 in)
Rating	Minimum 10 A, 125 V

Using this unit at a voltage other than 120V may require the use of a different line cord or attachment plug, or both. To reduce the risk of fire or electric shock, refer servicing to qualified service personnel.

## For customers in the USA

This equipment has been tested and found to comply with the limits for a Class A digital device, pursuant to Part 15 of the FCC Rules. These limits are designed to provide reasonable protection against harmful interference when the equipment is operated in a commercial environment. This equipment generates, uses, and can radiate radio frequency energy and, if not installed and used in accordance with the instruction manual, may cause harmful interference to radio communications. Operation of this equipment in a residential area is likely to cause harmful interference in which case the user will be required to correct the interference at his own expense.

You are cautioned that any changes or modifications not expressly approved in this manual could void your authority to operate this equipment.

The shielded interface cable recommended in this manual must be used with this equipment in order to comply with the limits for a digital device pursuant to Subpart B of Part 15 of FCC Rules.

## For customers in Canada

This Class A digital apparatus meets all requirements of the Canadian Interference-Causing Equipment Regulations.

## Pour les utilisateurs au Canada

Cet appareil numérique de la classe A respecte toutes les exigences du Règlement sur le matériel brouilleur du Canada.

## Für Kunden in Deutschland

Dieses Produkt kann im kommerziellen und in begrenztem Maße auch im industriellen Bereich eingesetzt werden. Dies ist eine Einrichtung, welche die Funk-Entstörung nach Klasse B besitzt.

## Voor de klanten in Nederland



Bij dit produkt zijn batterijen geleverd. Wanneer deze leeg zijn, moet u ze niet weggooien maar inleveren als KCA.

- Dit apparaat bevat een Li-ion batterij voor memory back-up.
- De batterij voor memory back-up is vastgesoldeerd op de BC printplaat BAT1.
- Raadpleeg uw leverancier over de verwijdering van de batterij op het moment dat u het apparaat bij einde levensduur afdankt.
- Gooi de batterij niet weg, maar lever hem in als KCA.

## Note

Be sure to use the supplied power cord for this monitor, or this monitor may not conform with the FCC Rules or EEC Directive 89/336/EEC.

## Remarque

Utiliser le cordon d'alimentation fourni pour ce moniteur, sinon il pourrait ne pas être conforme aux règles FCC ou à la directive CEE 89/336/EEC.

## Hinweis

Dieser Monitor darf ausschließlich mit dem mitgelieferten Netzkabel betrieben werden, weil andernfalls der Monitor nicht mehr die FCC-Vorschriften oder die EG-Richtlinie 89/336/EWG erfüllt.

## Nota

Utilice sin falta el cable eléctrico que viene con este monitor; de lo contrario el monitor puede no cumplir con los reglamentos de la FCC o de la directiva 89/336/EEC de la Comunidad Europea.

## Nota

Assicurarsi di usare il cavo di alimentazione in dotazione per questo monitor, altrimenti il monitor può non essere conforme alle norme FCC o alla Direttiva CEE/89/336.

The operating instructions mentioned here are partial abstracts from the Operating Instruction Manual.

# SECTION 1. GENERAL

- BVM-14E1E/14E1U/14E5E/14E5U/14F1E/14F1U/14F5E/14F5U
- BVM-20E1E/20E1U/20F1E/20F1U

## Overview

The BVM-14E1E/14E1U/14F1E/14F1U, BVM-14E5E/14E5U/14F5E/14F5U and BVM-20E1E/20E1U/20F1E/20F1U Trinitron®<sup>1)</sup> Color Video Monitors are high-performance 14- and 20-inch color video monitors. They are suitable for television stations or video production houses, where precise image reproduction is required.

1) Trinitron® is a registered trademark of Sony Corporation.

### Features

#### High resolution picture tube

The HR Trinitron picture tube produces a clear, high resolution image.

Model	Aperture grille pitch	Resolution at the center of the picture
BVM-14E1E/14E1U BVM-14E5E/14E5U	0.22 mm	900 TV lines
BVM-14F1E/14F1U BVM-14F5E/14F5U	0.25 mm	800 TV lines
BVM-20E1E/20E1U	0.25 mm	1000 TV lines
BVM-20F1E/20F1U	0.30 mm	900 TV lines

#### Separate control unit

Both the BVM-20E1E/20E1U/20F1E/20F1U and BVM-14E1E/14E1U/14F1E/14F1U are controlled by a separate control unit, such as a BKM-10R Monitor Control Unit. Use of a separate control unit reduces the space needed for the equipment. With the BVM-20E1E/20E1U/20F1E/20F1U, it is also possible to attach the BKM-10R with an optional BKM-32H Monitor Control Unit Attachment Kit.

#### Data exchange between monitors

Up to 32 units of the BVM-20E1E/20E1U/20F1E/20F1U and BVM-14E1E/14E1U/14F1E/14F1U can be connected via serial remote connectors and controlled by a single BKM-10R Monitor Control Unit or by a single BVM-14E5E/14E5U/14F5E/14F5U Color Video Monitor which contains integrated control units. By copying memory card data and transmitting data through the serial remote connector, it is possible to share adjustment and setup condition data between the monitors.

#### Controlling monitor groups

Up to 32 monitors can be controlled from the BVM-14E5E/14E5U/14F5U/14F5U. First, using the monitor menus, assign a monitor address number to each monitor, divide the monitors into groups, and assign a group number to each group. Then you can use the BVM-14E5E/14E5U/14F5U/14F5U to control individual monitors or monitor groups simply by entering monitor address or group numbers. You can also execute the same operation on all connected monitors, or use the BVM-14E5E/14E5U/14F5U/14F5U to put all connected monitors into the same setup and adjustment state.

#### Setup and adjustment with the monitor memory card

You can use an optional BKM-12Y Monitor Memory Card to save and load monitor setup and adjustment data. If your system includes more than one monitor, you can use the monitor memory cards to exchange data between monitors. This makes it easy to put all monitors in your system into the same setup and adjustment state.

#### Standard auto alignment system

Decoder chroma and phase adjustment, as well as color temperature control, may be performed with the auto alignment system. This makes it possible to coordinate settings among multiple monitors.

#### Expandable input capability

The input connector configuration may be easily modified by simply sliding optional decoder adaptors or input expansion adaptors into input option slots at the rear of the monitor. The BVM-14E5E/14E5U/14F5E/14F5U/20E1E/20E1U/20F1E/20F1U may be fitted with up to four adaptors, and the BVM-14E1E/14E1U/14F1E/14F1U will accept two.

#### 4:3/16:9 dual aspect ratio design

The monitors can be changed to either 4:3 or 16:9 aspect ratios with just a simple switching operation from an optional monitor control unit such as a BKM-10R. The screen can be also changed to 4:3 or 16:9 display by the replacement of a mask (no tools required).

#### Stable color temperature

The internal beam current feedback circuit maintains a constant color temperature over long periods of time.

#### Blue-only mode convenient for monitoring noise

All three CRT cathodes can be driven with a blue signal, producing a monochrome display. This mode is convenient for chroma and phase adjustment, and for monitoring VTR noise.

#### Menu operation

The monitor's various functions and operating conditions can be set with on-screen menus. Menu operations are performed using an optional monitor control unit such as a BKM-10R.

#### Other features

- Compatible with the ISR (Interactive Status Reporting) system.
- Has both RS-485 serial remote and relay contact parallel remote control connectors.
- Built-in safe area display and test signal generator for crosshatch, 100% white signal, 20% grey signal, grey scale, and PLUGE (Picture Line Up Generating Equipment).
- Built-in VITC (Vertical Interval Time Code) reader.
- Built-in copion vision.
- Pulse cross function for simultaneous checking of the horizontal and vertical synchronization signals. VITS (Vertical Interval Test Signal) checking is also possible.
- Auto and manual degaussing.
- Built-in CRT protection circuit.
- The BVM-14E1E/14E1U/14E5E/14E5U/14F1E/14F1U/14F5E/14F5U and BVM-20E1E/20E1U/20F1E/20F1U may be mounted in an EIA-standard 19-inch rack, using an optional BKM-30E20/30E14/31E14 Rack Mount Kit.

### Options

#### For External Control

##### BKM-10R Monitor Control Unit

External control unit for the BVM-14E1E/14E1U/14F1E/14F1U and BVM-20E1E/20E1U/20F1E/20F1U.

##### BKM-12Y Monitor Memory Card

Memory cards which can be read and written by the BKM-10R and BVM-14E5E/14E5U/14F5E/14F5U.

#### For Screen

##### BKM-33H20 Monitor 16:9 Mask

Adapts the BVM-BVM-20E1E/20E1U/20F1E/20F1U screen for 16:9 aspect ratio display.

##### BKM-33H14 Monitor 16:9 Mask

Adapts the BVM-14E1E/14E1U/14F1E/14F1U/14E5E/14E5U/14F5E/14F5U screen for 16:9 aspect ratio display.

#### For Installation

##### BKM-30E20 Rack Mount Kit

Rack mount kit for mounting the BVM-20E1E/20E1U/20F1E/20F1U in an EIA standard 19-inch rack.

##### BKM-30E14 Rack Mount Kit

Rack mount kit for mounting the BVM-14E5E/14E5U/14F5E/14F5U in an EIA standard 19-inch rack.

##### BKM-31E14 Rack Mount Kit

Rack mount kit for mounting the BVM-14E1E/14E1U/14F1E/14F1U in an EIA standard 19-inch rack.

##### BKM-32H Monitor Control Unit Attachment Kit

Assembly kit for attaching a BKM-10R Monitor Control Unit to the BVM-20E1E/20E1U/20F1E/20F1U monitor.

#### Decoder and Input Expansion Adaptors

The input connector panel is configured by sliding optional decoder adaptors and/or input expansion adaptors into input option slots at the rear of the monitor. The BVM-14E5E/14E5U/14F5E/14F5U/20E1E/20E1U/20F1E/20F1U may be fitted with up to four adaptors, and the BVM-14E1E/14E1U/14F1E/14F1U will accept two.

#### Note

When installing the adaptors, be sure to perform the necessary input signal setup with the INPUT CONFIGURATION menu. If the setup is not performed, the adaptors may not function correctly.

For information about the INPUT CONFIGURATION menu, see "Setting the Input Configuration — INPUT CONFIGURATION Menu".

## Overview

### BKM-20D SDI 4:2:2 Decoder Adaptor

Includes decoders for serial digital component signals (525/625). Input/output connectors for three serial digital channels (component inputs only) and three analog channels. The input signal type for each connector is set with the INPUT CONFIGURATION menu, in accordance with the configuration of the connector panel.

### BKM-21D SDI Multi Decoder Adaptor

Includes decoders for serial digital signals (525/625 component and NTSC/PAL composite) and analog composite signals (NTSC and PAL). Input/output connectors for three serial digital channels and three analog channels are equipped. The input signal type for each connector is set with the INPUT CONFIGURATION menu, in accordance with the configuration of the connector panel.

### BKM-24N NTSC Decoder Adaptor

Includes a decoder for analog composite NTSC signals and input/output connectors for six analog channels. The input signal type for each connector is set with the INPUT CONFIGURATION menu, in accordance with the configuration of the connector panel.

### BKM-25P PAL Decoder Adaptor

Includes a decoder for analog composite PAL signals and input/output connectors for six analog channels. The input signal type for each connector is set with the INPUT CONFIGURATION menu, in accordance with the configuration of the connector panel.

### BKM-26M PAL-M Decoder Adaptor

Includes a decoder for analog composite PAL-M signals and input/output connectors for six analog channels. The input signal type for each connector is set with the INPUT CONFIGURATION menu, in accordance with the configuration of the connector panel.

### BKM-27T Tri-Standard Decoder Adaptor

Includes decoders for analog composite NTSC, PAL, and SECAM signals and input/output connectors for six analog channels. The input signal type for each connector is set with the INPUT CONFIGURATION menu, in accordance with the configuration of the connector panel.

### BKM-22X SDI Input Expansion Adaptor

Used with decoder adaptors, increases the number of input/output channels. Includes input/output connectors for three serial digital channels and three analog channels. The input signal type for each connector is set with the INPUT CONFIGURATION menu, in accordance with the configuration of the connector panel.

### BKM-28X Analog Input Expansion Adaptor

Used with decoder adaptors, increases the number of input/output channels. Includes input/output connectors for six analog channels. The input signal type for each connector is set with the INPUT CONFIGURATION menu, in accordance with the configuration of the connector panel.

## Connector Panel Configuration

The BVM-14E1E/14E1U/14E5E/14E5U/14F1E/14F1U/14F5E/14F5U and BVM-20E1E/20E1U/20F1E/20F1U come standard with connectors for one channel of Y/R-Y/B-Y or RGB. By adding optional decoder adaptors and/or input expansion adaptors, the input/output connector panel can be assembled in a wide variety of configurations.

The signals that each of the adaptors' connectors supports are given in the table below. The type of signal to be applied to each input/output connector is set with the INPUT CONFIGURATION menu.

When the type of input signal determines, each connector of the installed adaptors is connected with the decoder for the corresponding signal over an internal bus. Therefore, if one decoder adaptor for a signal is installed, the signal input from any connector of the installed adaptors can be decoded.

For information about the INPUT CONFIGURATION menu, see "Setting the Input Configuration —INPUT CONFIGURATION Menu"

		Adaptor name							
		BKM-20D SDI 4:2:2 Decoder Adaptor	BKM-21D SDI Multi Decoder Adaptor	BKM-24N NTSC Decoder Adaptor	BKM-25P PAL Decoder Adaptor	BKM-26M PAL-M Decoder Adaptor	BKM-27T Tri- Standard Decoder Adaptor	BKM-22X SDI Input Expansion Adaptor	BKM-28X Analog Input Expansion Adaptor
Serial digital input	Component 525/625	⊙	⊙					○	
	Composite NTSC	○	⊙					○	
	Composite PAL	○	⊙					○	
Analog input	Composite NTSC	○	⊙	⊙	○	○	⊙	○	○
	Composite PAL	○	⊙	○	⊙	○	⊙	○	○
	Composite PAL-M	○	○	○	○	⊙	○	○	○
	Composite SECAM	○	○	○	○	○	⊙	○	○
	Y/R-Y/B-Y 525/625	⊙	⊙	⊙	⊙	⊙	⊙	⊙	⊙
	RGB 525/ 625	⊙	⊙	⊙	⊙	⊙	⊙	⊙	⊙
	Y/C NTSC			⊙	○	○	⊙		○
	Y/C PAL			○	⊙	○	⊙		○
Y/C PAL-M			○	○	⊙	○		○	
Number of digital inputs		3	3	—	—	—	—	3	—
Number of analog input		3	3	6	6	6	6	3	6

⊙: Independent input possible

○: Input possible when used with decoder adaptor

## Overview

### Decoder Adaptor Priority

The table on the right shows which decoder adaptor will be selected preferentially when more than one decoder adaptor which can accept the NTSC or PAL signal format have been installed in the monitor.

For example, when a BKM-24N and a BKM-27T are installed and an NTSC signal is selected, the NTSC signal connected to the BKM-24N's input connectors and the NTSC signal connected to the BKM-27T's input connectors are both processed by the decoder on the BKM-24N.

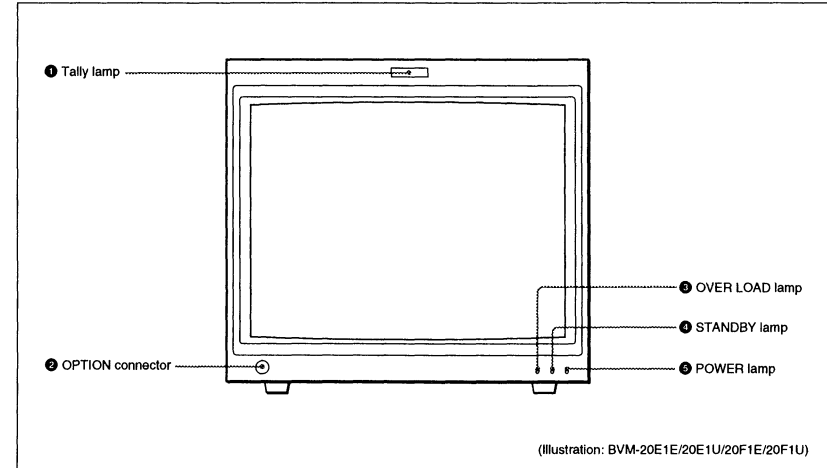
Input signal type and format		Decoder adaptor			
		BKM-24N	BKM-25P	BKM-27T	BKM-21D
Composite signal	NTSC	1		3	2
	PAL		1	3	2
Y/C signal	NTSC	1		2	
	PAL		1	2	

Numbers in the table show priority.

## Location and Function of Parts

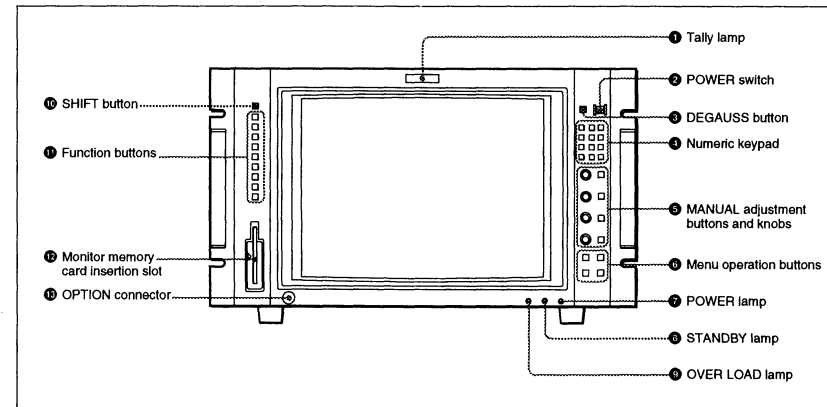
### BVM-14E1E/14E1U/14F1E/14F1U/20E1E/20E1U/20F1E/20F1U

#### Front Panel



### BVM-14E5E/14E5U/14F1E/14F5U

#### Front Panel





## Location and Function of Parts

### 1 Tally lamp

With factory settings, the Tally lamp lights when pins No. 3 and No. 8 of the REMOTE 2 connector on the rear panel are connected. By changing the setting in the REMOTE menu, different pins on the remote connector can be used to control the tally lamp.

For information about the REMOTE menu, see "Assigning the Remote Control Functions—REMOTE MenuZ".

### 2 OPTION connector

(BVM-14E1E/14E1U/14F1E/14F1U/20E1E/20E1U/20F1E/20F1U)

### 15 OPTION connector

(BVM-14E5E/14E5U/14F5E/14F5U)

Connector for future expansion.

### 3 OVER LOAD lamp

(BVM-14E1E/14E1U/14F1E/14F1U/20E1E/20E1U/20F1E/20F1U)

### 9 OVER LOAD lamp

(BVM-14E5E/14E5U/14F5E/14F5U)

Lights to warn of CRT overload.

### 4 STANDBY lamp

(BVM-14E1E/14E1U/14F1E/14F1U/20E1E/20E1U/20F1E/20F1U)

### 6 STANDBY lamp

(BVM-14E5E/14E5U/14F5E/14F5U)

Lights when the monitor is in standby mode. The monitor will be in standby mode under the following conditions:

- The MAIN POWER switch (on the rear panel) is turned on (the STANDBY lamp will blink for a few moments after the switch is turned on).
- The monitor is changed from operation mode to standby mode via the monitor control unit such as the BKM-10R.

### 5 POWER lamp

(BVM-14E1E/14E1U/14F1E/14F1U/20E1E/20E1U/20F1E/20F1U)

### 7 POWER lamp

(BVM-14E5E/14E5U/14F5E/14F5U)

Lights when the monitor is put into operation mode by an optional monitor control unit such as a BKM-10R.

#### Note

When the STANDBY lamp 4 is blinking, the monitor cannot be put into operation mode (internal data initialization is taking place). Wait until the STANDBY lamp 4 is steadily lit.

### 2 POWER switch

(BVM-14E5E/14E5U/14F5E/14F5U)

Press to power the BVM-14E5E/14E5U/14F5E/14F5U on or off. If your system includes more than one monitor, you can use the ADDRESS menu to power a selected monitor on or off, or to power all monitors on or off at once.

For more information about the ADDRESS menu, see "Selecting the Monitor to Control—ADDRESS Menu".

### 3 DEGAUSS button

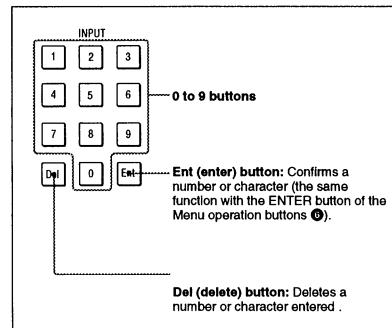
(BVM-14E5E/14E5U/14F5E/14F5U)

Press to manually degauss the monitor CRT. When degaussing repeatedly, wait for 5 minutes before pressing the button again. (The monitor CRT is degaussing automatically each time the power is turned on.)

### 4 Numeric keypad

(BVM-14E5E/14E5U/14F5E/14F5U)

Use the numeric keypad to enter menu settings and channel numbers for signals that you want to input to the monitor.



### 5 MANUAL adjustment buttons and knobs (BVM-14E5E/14E5U/14F5E/14F5U)

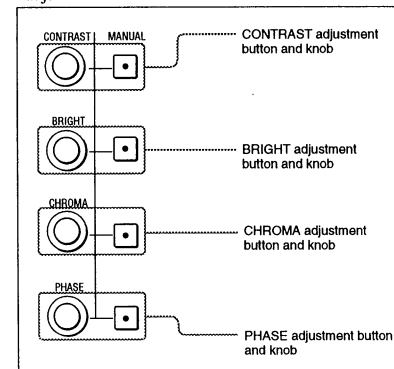
Each press of one of these buttons turns the button's green LED on or off. When the corresponding button is on (lit), you can rotate the knobs to adjust the picture's contrast, brightness (black level), chroma, and phase. These buttons are also used to enter adjustment values from the menus.

You can use the CONTROL PRESET ADJ menu to set preset values for each adjustment item.

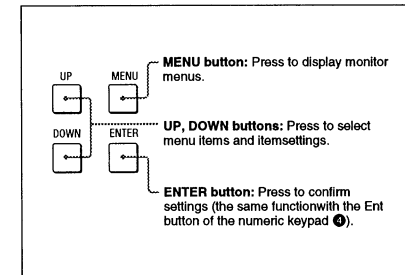
For more information about the CONTROL PRESET ADJ menu, see "Preset Adjustment of the Picture Level Control Knobs—CONTROL PRESET ADJ Menu".

#### Notes on using a SECAM, PAL D, component, and component digital system

- The phase of component signals cannot be adjusted.
- The phase and chroma of RGB signals cannot be adjusted.



### 6 Menu operation buttons (BVM-14E5E/14E5U/14F5E/14F5U)



For more information about using monitor menus, see "Basic Menu Operations".

### 10 SHIFT button (BVM-14E5E/14E5U/14F5E/14F5U)

Each of the Function buttons 1 has a Shift On function as well as a Shift Off function. Press this button to select Shift On or Shift Off functions. Each time you press this button, its orange LED lights (Shift On) or goes out (Shift Off).

**Shift On:** Use the function indicated on the right of the Function button.

**Shift Off:** Use the function indicated on the left of the Function button.

## Location and Function of Parts

### 11 Function buttons (BVM-1414ESE/14E5U/14F5E/14F5U)

Use these buttons to control the operation of the monitor.

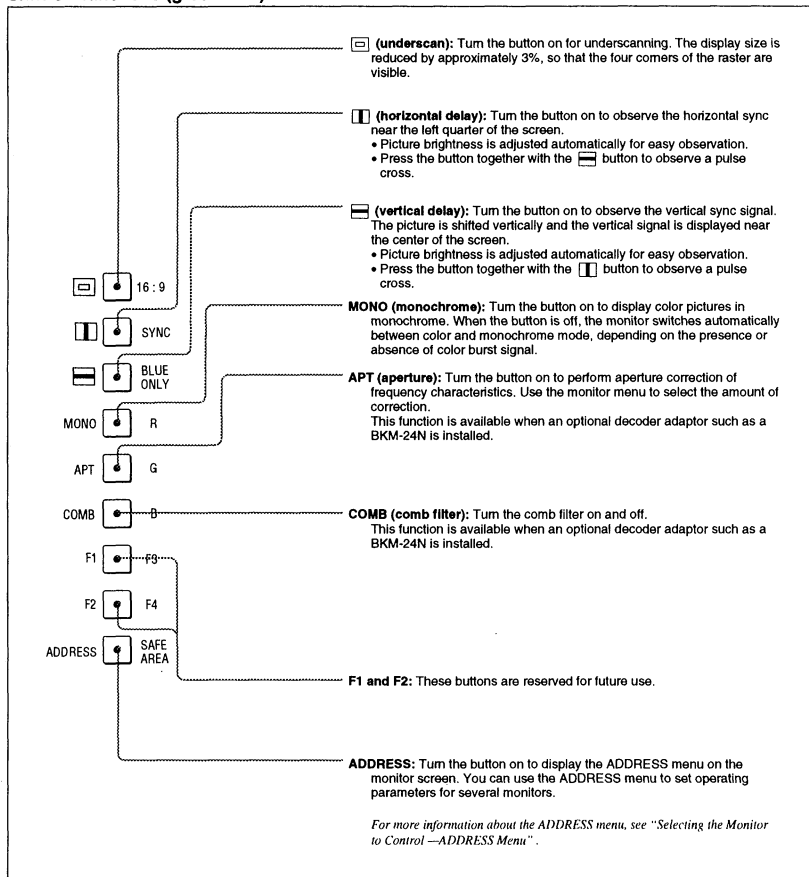
Each of these buttons has a Shift On function, indicated below the button, as well as a Shift Off function, indicated above the button. Press the SHIFT button **10** to select the desired function.

Each time you press one of these buttons, its LED lights or goes out and the function of the button selected with the SHIFT button **10** is turned on or off. The LED color change whether you select Shift Off functions or Shift On functions.

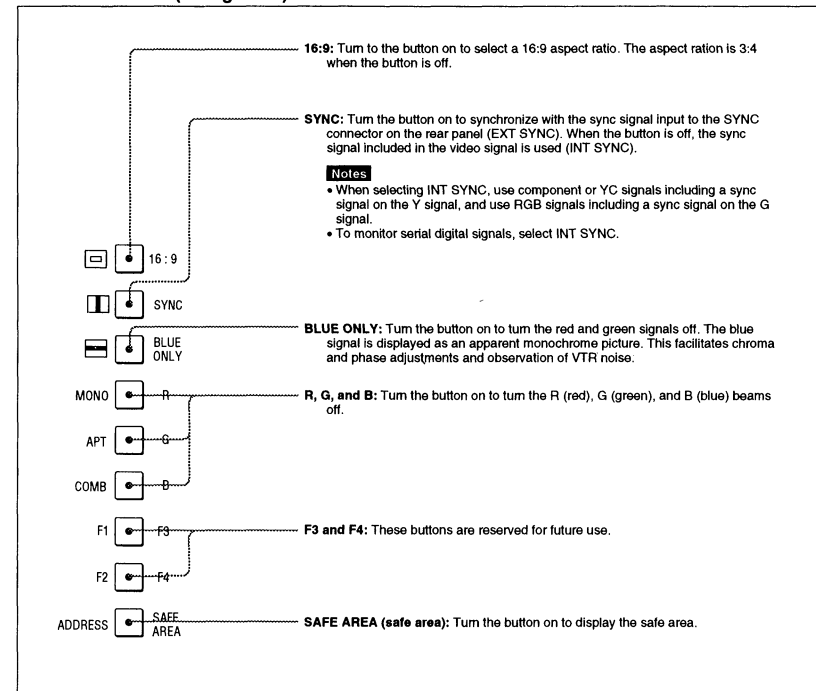
**For Shift Off functions:** Green LED

**For Shift On functions:** Orange LED

### Shift Off functions (green LED)



### Shift On functions (Orange LED)



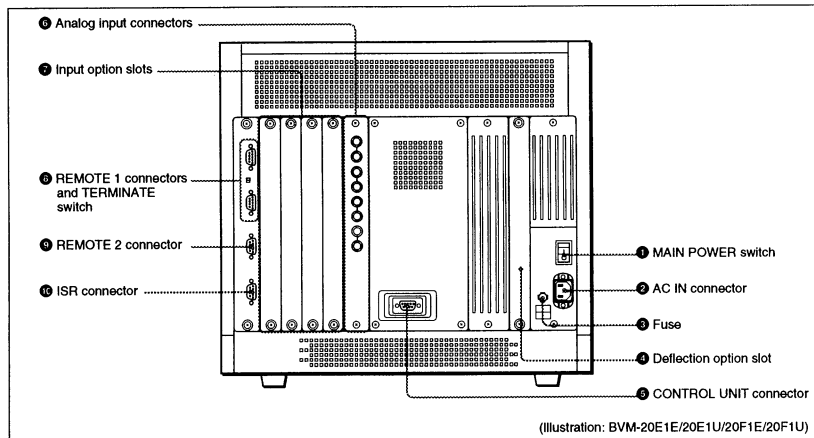
### 12 Monitor memory card insertion slot (BVM-14E5E/14E5U/14F5E/14F5U)

Insert an optional BKM-12Y Monitor Memory Card.

## Location and Function of Parts

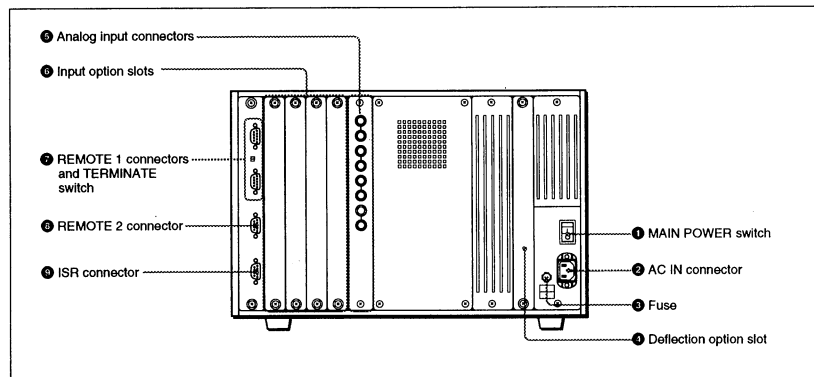
### BVM-14E1E/14E1U/14F1E/14F1U/20E1E/20E1U/20F1E/20F1U

#### Rear Panel



### BVM-14E5E/14E5U/14F5E/14F5U

#### Rear Panel



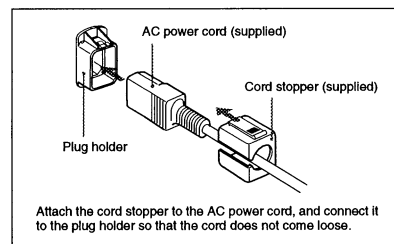
#### 1 MAIN POWER switch

When turned on, the monitor enters standby mode. By a setting in the SYSTEM CONFIGURATION menu, see "Setting the Channel Selection Method and Power-Up Conditions—SYSTEM CONFIGURATION Menu".

For information about the SYSTEM CONFIGURATION menu, see "Setting the Channel Selection Method and Power-Up Conditions—SYSTEM CONFIGURATION Menu".

#### 2 AC IN connector (3-pin)

Connects the monitor to an AC power source, via the supplied AC power cord.



#### 3 Fuse

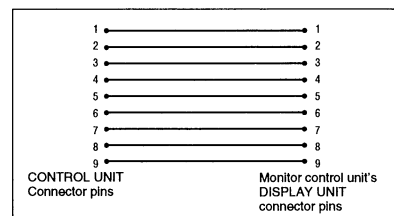
Use a 4 A fuse for 100 to 120 V AC or a T 3.15 A fuse for 220 to 240 V AC.

#### 4 Deflection option slot

Slot for future expansion.

#### 5 CONTROL UNIT connector (female, D-sub 9-pin) (BVM-14E1E/14E1U/14F1E/14F1U/20E1E/20E1U/20F1E/20F1U)

Connects a monitor control unit such as the BKM-10R using a straight cable with D-sub 9-pin plugs such as an RCC-5G (not supplied) as shown in the figure.

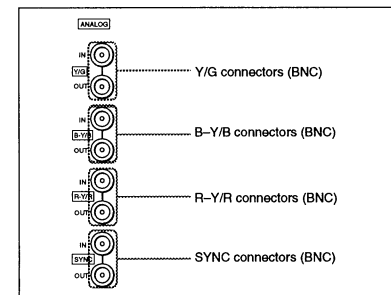


#### 6 Analog input connectors

(BVM-14E1E/14E1U/14F1E/14F1U/20E1E/20E1U/20F1E/20F1U)

#### 7 Analog input connectors

(BVM-14E5E/14E5U/14F5E/14F5U)



RGB signals, component signals (Y, R-Y, and B-Y), or composite sync signals can be fed in the IN connectors. The type of signal applied to each connector is set with the INPUT CONFIGURATION menu. The OUT connectors are used for loop-through output of the input signal. When not using loop-through, connect a 75-ohm terminator (not supplied) to the OUT connectors.

For information about the INPUT CONFIGURATION menu, see "Setting the Input Configuration—INPUT CONFIGURATION menu".

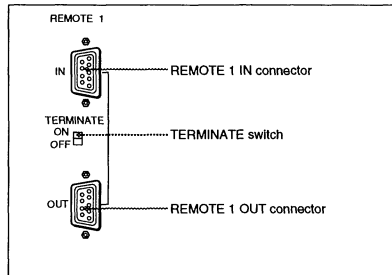
#### 7 Input option slots (BVM-14E1E/14E1U/14F1E/14F1U/20E1E/20E1U/20F1E/20F1U)

#### 8 Input option slots (BVM-14E5E/14E5U/14F5E/14F5U)

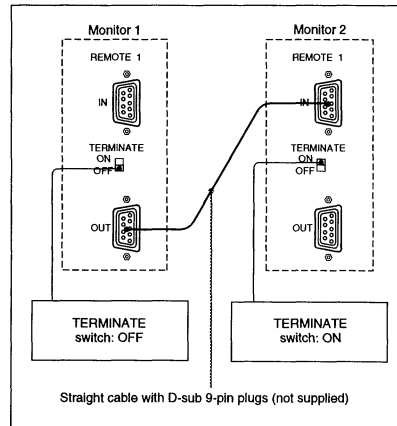
The BVM-14E5E/14E5U/14F5E/14F5U/20E1E/20E1U/20F1E/20F1U may be fitted with up to four adaptors, and the BVM-14E1E/14E1U/14F1E/14F1U will accept two.

## Location and Function of Parts

- ⑧ **REMOTE 1 connectors (female, D-sub 9-pin), and TERMINATE switch** (BVM-14E1E/14E1U/14F1E/14F1U/20E1E/20E1U/20F1E/20F1U)
- ⑦ **REMOTE 1 connectors (female, D-sub 9-pin), and TERMINATE switch** (BVM-14E5E/14E5U/14F5E/14F5U)

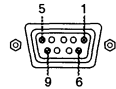


These are RS-485 serial interface connectors, used for connecting two or more BVM-series monitors. The IN and OUT connectors form a loop-through connection. Set the TERMINATE switch to OFF when loop-through is used, to ON when it is not. Connect two monitors using a straight cable with D-sub 9-pin plugs such as an RCC-5G (not supplied) as shown in the figure.



- ⑨ **REMOTE 2 connectors (female, D-sub 9-pin)** (BVM-14E1E/14E1U/14F1E/14F1U/20E1E/20E1U/20F1E/20F1U)
- ⑧ **REMOTE 2 connectors (female, D-sub 9-pin)** (BVM-14E5E/14E5U/14F5E/14F5U)

Forms a parallel switch and controls the monitor externally. The pin arrangement and factory setting function assigned to each pin are given below.



Pin number	Function
1	Set input signal channel 1 (numeric keypad function)
2	Set input signal channel 2 (numeric keypad function)
3	Select sync signal (SYNC button function)
4	Set the screen to monochrome, or set for automatic switching based on the input signal (MONO button function)
5	Safe area on/off (SAFE AREA button function)
6, 7	Undefined
8	Tally lamp on/off
9	Ground

All pin function assignments can be changed with the REMOTE menu.

For information about the REMOTE menu, see "Assigning the Remote Control Functions—REMOTE Menu".

To switch each function between on and off or between enable and disable, change pin connections in the following way.

- On or enabled:** Short each pin and pin 9 together.
- Off or disabled:** Leave each pin open.

- ⑩ **ISR (Interactive Status Reporting) connector (female, D-sub 9-pin)** (BVM-14E1E/14E1U/14F1E/14F1U/20E1E/20E1U/20F1E/20F1U)
  - ⑨ **ISR (Interactive Status Reporting) connector (female, D-sub 9-pin)** (BVM-14E5E/14E5U/14F5E/14F5U)
- Connect to the ISR system.

## Guidance for Basic Monitor Operations

The following table shows how to use a monitor, control unit and menus to perform basic monitor operations.

Operations	Monitor/control unit parts	Menus
Selecting signals to be monitored	Specify the channel number with 0 to 9 buttons of the numeric keypad. 1 to 90: channel numbers for external input signals 91 to 95: channel numbers for signals from the internal test signal generator 91: PLUGE (Picture Line UP Generating Equipment) 92: 20% gray signal 93: 100% white signal 94: five-step gray scale 95: crosshatch	<ul style="list-style-type: none"> <li>• INPUT CONFIGURATION menu</li> <li>• SYSTEM CONFIGURATION menu</li> </ul>
Remote control	<ul style="list-style-type: none"> <li>• REMOTE 1 connector</li> <li>• REMOTE 2 connector</li> </ul>	<ul style="list-style-type: none"> <li>• REMOTE menu</li> <li>• ADDRESS menu</li> </ul>
Adjusting the screen and signals	<ul style="list-style-type: none"> <li>• Function buttons</li> <li>• MANUAL adjustment buttons and knobs</li> </ul> <p>Refer to the operation manual for the control unit or the built-in control unit monitor on how to use.</p>	<ul style="list-style-type: none"> <li>• CONTROL PRESET ADJ menu</li> <li>• COLOR TEMP ADJ menu</li> <li>• ALIGNMENT menu</li> <li>• ON SCREEN SET menu</li> <li>• KEY PROTECT menu</li> </ul>
Data transfer	<ul style="list-style-type: none"> <li>• REMOTE 1 connector</li> <li>• Monitor memory card</li> </ul> <p>Refer to the operation manual for the control unit or the built-in control unit monitor on how to use.</p>	<ul style="list-style-type: none"> <li>• MEMORY CARD menu</li> <li>• COPY menu</li> </ul>
Menu operations	<ul style="list-style-type: none"> <li>• Menu operation buttons</li> <li>• ADDRESS button of the function buttons</li> </ul> <p>Refer to the operation manual for the control unit or the built-in control unit monitor on how to use.</p>	<ul style="list-style-type: none"> <li>• Basic menu operations</li> <li>• PASSWORD menu</li> </ul>

# Basic Menu Operations

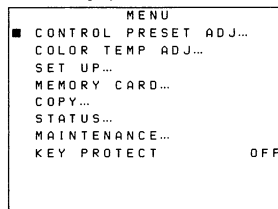
The various functions and operating conditions of the BVM-14E1E/14E1U/14F1E/14F1U or BVM-20E1E/201EU/20F1E/20F1U can be set with on-screen menus. Menu operations are performed with an optional control unit such as the BKM-10R Monitor Control Unit or a built-in control unit monitor such as the BVM-14E5E/14E5U/14F5E/14F5U. Herein, the operating procedures for the BKM-10R will be described.

*The names of buttons and adjustment knobs may vary depending on the control unit or monitor you use. Consult the operating manual for your control unit or monitor, and use the buttons and knobs with the same functions as those described here.*

## Displaying the Menus

Press the MENU button.

The menu list is displayed on the screen.



Menu list

Choose the menu for the adjustment or setup you wish to perform. The adjustments and settings which can be made with the menus are described below.

**CONTROL PRESET ADJ menu:** Sets the preset values for the input signal contrast, brightness, chroma, and phase.

**COLOR TEMP ADJ menu:** Sets the color temperature.

**SET UP menus:** A menu group for performing monitor setup, consisting of the following.

**INPUT CONFIGURATION menu:** Sets the input channel.

**REMOTE menu:** Sets the remote control functionality.

**PASSWORD menu:** Sets passwords for menus.

**SYSTEM CONFIGURATION menu:** Sets the input channel selection method and power-up conditions.

**ON SCREEN SET menu:** Sets data about the screen display.

**ALIGNMENT menu:** Used to adjust the screen convergence and geometry.

**MEMORY CARD menu:** Operates on data in the memory card.

**COPY menu:** Copies set-up data to other connected monitors.

**STATUS menu:** Displays the information about the monitor or options installed in the monitor.

**MAINTENANCE menu:** Menu for maintenance (typically not used).

**KEY PROTECT:** When set to ON, function buttons on the control unit (with the exception of menu operation buttons) will be disable. When set to OFF, key protection is removed.

### To exit the menus

Press the MENU button repeatedly until the menu disappears.

## ADDRESS Menu

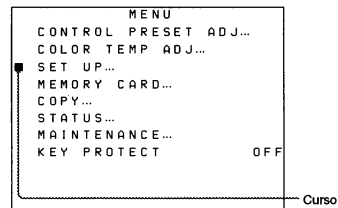
The ADDRESS menu is used to select the monitor or the monitor group, so that when several monitors are connected together via serial remort ports, the control panel can select which monitor to control.

To display or exit the ADDRESS menu, press the ADDRESS button. The method of choosing menu items and changing settings is the same as with the other menus.

*For information about the ADDRESS menu, see "Selecting the Monitor to Control—ADDRESS Menu".*

## Selecting the Menu

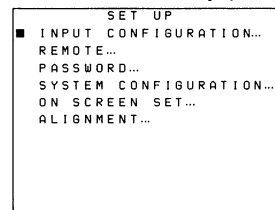
1 Using the UP or DOWN button, move the cursor to the desired item. (Example: move the cursor with the DOWN button to SET UP.)



Menu list

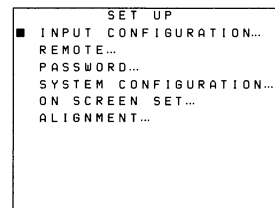
2 Press the ENTER button.

The SET UP menu list is displayed.



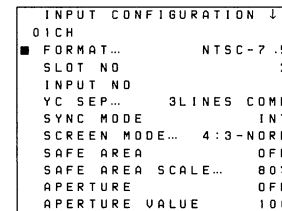
SET UP menu list

3 Using the UP or DOWN button, move the cursor to the desired item. (Example: select the INPUT CONFIGURATION menu.)



4 Press the ENTER button.

The INPUT CONFIGURATION menu is displayed.



INPUT CONFIGURATION menu

The "↓" to the right of the menu title indicates that the menu continues onto another page. Items which are followed by "..." have sub-lists for settings.

## Basic Menu Operations

### Changing the Settings

The setting procedure differs with different menu items. There are four different types of settings:

- (1) Choosing one of two or more selections on a current setting list (items without "... " mark)
- (2) Choosing one of two or more selections using sub-setting list (items with "... " mark)
- (3) Entering a numerical value
- (4) Entering characters

### Choosing One of Two or More Selections about Items without "... " Mark

Example: changing the SYNC MODE setting in the INPUT CONFIGURATION menu

- 1 Move the cursor to the SYNC MODE line in the INPUT CONFIGURATION menu.

```

INPUT CONFIGURATION ↓
01CH
FORMAT...      NTSC-7 .5
SLOT NO       2
INPUT NO      1
YC SEP...    3LINES COMB
■ SYNC MODE   INT
SCREEN MODE... 4:3-NORM
SAFE AREA     OFF
SAFE AREA SCALE... 80%
APERTURE      OFF
APERTURE VALUE 100
INPUT CONFIGURATION menu
  
```

- 2 Press the ENTER button.

INT is displayed in yellow text.

- 3 By pressing either the UP or DOWN button, INT changes to EXT.

```

INPUT CONFIGURATION ↓
01CH
FORMAT...      NTSC-7 .5
SLOT NO       2
INPUT NO      1
YC SEP...    3LINES COMB
■ SYNC MODE   EXT
SCREEN MODE... 4:3-NORM
SAFE AREA     OFF
SAFE AREA SCALE... 80%
APERTURE      OFF
APERTURE VALUE 100
  
```

Each time the UP or DOWN button is pressed, the value switches between INT and EXT.

- 4 When EXT is displayed, press the ENTER button.

The SYNC MODE is set to EXT. (EXT is again displayed in white text.)

### Choosing One of Two or More Selections about Items with "... " Mark

Example: changing the SCREEN MODE setting in the INPUT CONFIGURATION menu

- 1 Move the cursor to the SCREEN MODE line in the INPUT CONFIGURATION menu.

```

INPUT CONFIGURATION ↓
01CH
FORMAT...      NTSC-7 .5
SLOT NO       2
INPUT NO      1
YC SEP...    3LINES COMB
SYNC MODE     INT
■ SCREEN MODE... 4:3-NORM
SAFE AREA     OFF
SAFE AREA SCALE... 80%
APERTURE      OFF
APERTURE VALUE 100
INPUT CONFIGURATION menu
  
```

- 2 Press the ENTER button.

The SCREEN MODE setting list is displayed.

```

SCREEN MODE
■ 4:3-NORM
  4:3-UNDR
  16:9-NORM
  16:9-UNDR
SCREEN MODE setting list
  
```

- 3 By pressing either UP and DOWN buttons, move the cursor to 16:9 - NORM.

```

SCREEN MODE
4:3-NORM
4:3-UNDR
■ 16:9-NORM
  16:9-UNDR
  
```

- 4 Press the ENTER button.

The display returns to the INPUT CONFIGURATION menu, and shows SCREEN MODE as the 16:9 - NORM setting.

```

INPUT CONFIGURATION ↓
01CH
FORMAT...      NTSC-7 .5
SLOT NO       2
INPUT NO      1
YC SEP...    3LINES COMB
SYNC MODE     INT
■ SCREEN MODE... 16:9-NORM
SAFE AREA     OFF
SAFE AREA SCALE... 80%
APERTURE      OFF
APERTURE VALUE 100
  
```

### Entering a Numerical Value

Example: changing the APERTURE VALUE setting in the INPUT CONFIGURATION menu to 85

The numeric keypad, UP and DOWN buttons, or PHASE knob can be used to enter numerical values.

- 1 Move the cursor to the APERTURE VALUE line in the INPUT CONFIGURATION menu.

```

INPUT CONFIGURATION ↓
01CH
FORMAT...      NTSC-7 .5
SLOT NO       2
INPUT NO      1
YC SEP...    3LINES COMB
SYNC MODE     INT
SCREEN MODE... 4:3-NORM
SAFE AREA     OFF
SAFE AREA SCALE... 80%
APERTURE      OFF
■ APERTURE VALUE 100
INPUT CONFIGURATION menu
  
```

- 2 Press the ENTER button.

The third digit in the value is displayed in yellow text, indicating that it can now be modified.

- 3 There are three ways to set the value:
  - Using the numeric keypad, enter "0", "8", and "5".
  - Press the DOWN button to change the value to "85".
  - Turn the PHASE knob counterclockwise to change the value to "85".

- 4 Press the ENTER button.

The APERTURE VALUE is set to 85. (The value is again displayed in white text.)

```

INPUT CONFIGURATION ↓
01CH
FORMAT...      NTSC-7 .5
SLOT NO       2
INPUT NO      1
YC SEP...    3LINES COMB
SYNC MODE     INT
SCREEN MODE... 4:3-NORM
SAFE AREA     OFF
SAFE AREA SCALE... 80%
APERTURE      OFF
■ APERTURE VALUE 085
  
```

### Entering Characters

Example: changing the CHANNEL NAME setting in the INPUT CONFIGURATION menu to CAM2

The PHASE knob or UP and DOWN buttons are used to enter characters.

- 1 Move the cursor to the CHANNEL NAME line in the INPUT CONFIGURATION menu (2/2).

```

INPUT CONFIGURATION ↑
01CH
FILTER         OFF
■ CHANNEL NAME... CAM
CONTROL       PRESET
COLOR TEMP... STD
H PHASE       100
COPY...
INPUT CONFIGURATION menu (2/2)
  
```

(continued)

## Basic Menu Operations

- 2** Press the ENTER button.

The CHANNEL NAME setting list is displayed.

```

CHANNEL NAME
PROG
EDIT
■ CAM
UTR
NEW NAME
    
```

CHANNEL NAME setting list

- 3** Using the UP or DOWN button, move the cursor to the NEW NAME line.

```

CHANNEL NAME
PROG
EDIT
CAM
UTR
■ NEW NAME
    
```

- 4** Press the ENTER button.

The "┘" is displayed on the last line of the list (in yellow).

```

CHANNEL NAME
PROG
EDIT
CAM
UTR
■ NEW NAME
┘
    
```

"┘" indicates the position where character input is possible.

- 5** Press the UP or DOWN buttons, or turn the PHASE knob, until "C" is displayed.

When the UP button is pressed, the display will cycle through letters, numbers, and symbols, in the following order. When the DOWN button is pressed, the display will cycle in the opposite order.

A, B, ..., Y, Z, 0, 1, ..., 8, 9, (, ), :, ;, ,, -, +, /, &, CH, (space), ┘

Press the ENTER button.

```

CHANNEL NAME
PROG
EDIT
CAM
UTR
■ NEW NAME
C┘
    
```

- 6** As in steps 4 and 5, use the UP or DOWN button or the PHASE knob to select "A", and press the ENTER button.

"CA" (white) "┘" (yellow) is displayed.

```

CHANNEL NAME
PROG
EDIT
CAM
UTR
■ NEW NAME
CA┘
    
```

- 7** As in steps 4 and 5, use the UP or DOWN button or the PHASE knob to enter "M" and "2".

"CAM2" (white) "┘" (yellow) is displayed. 20 characters can be entered as a channel name.

```

CHANNEL NAME
PROG
EDIT
CAM
UTR
■ NEW NAME
CAM2┘
    
```

Check the entered name, and if it is correct, go on to step 8.

**To correct the entered text**

Example: change "CAM2" to "CAM-2"

- 7-1)** Press the Del button of the numeric keypad to delete "2".

```

CHANNEL NAME
PROG
EDIT
CAM
UTR
■ NEW NAME
CAM┘
    
```

- 7-2)** Enter "-" and "2".

```

CHANNEL NAME
PROG
EDIT
CAM
UTR
■ NEW NAME
CAM-2┘
    
```

Check the modified text, and if it is correct, go on to step 8.

- 8** Press the ENTER button.

The INPUT CONFIGURATION menu appears, and the CHANNEL NAME is set to the name you entered (up to six characters from the head of the name are displayed).

```

INPUT CONFIGURATION ↑
01CH
FILTER OFF
■ CHANNEL NAME... CAM2
CONTROL PRESET
COLOR TEMP... STD
H PHASE 100
COPY...
    
```

**Using default names**

Example: copy "CAM" and change it to "CAM2"

- 1** Using the UP or DOWN button, move the cursor to "CAM".

```

CHANNEL NAME
PROG
EDIT
■ CAM
UTR
NEW NAME
    
```

- 2** Press the ENTER button.

"CAM" (white) "┘" (yellow) is displayed on the bottom line of the screen.

```

CHANNEL NAME
PROG
EDIT
CAM
UTR
■ NEW NAME
CAM┘
    
```

(continued)

## Basic Menu Operations

- 3 Using the UP or DOWN button or PHASE knob, enter "2".

```

CHANNEL NAME
PROG
EDIT
CAM
UTR
■ NEW NAME
CAM2J
  
```

- 4 Press the ENTER button.

The INPUT CONFIGURATION menu appears, and the CHANNEL NAME is set to "CAM2".

```

INPUT CONFIGURATION ↑
O I C H
FILTER OFF
■ CHANNEL NAME... CAM2
CONTROL PRESET
COLOR TEMP... STD
H PHASE 100

COPY...
  
```

## Preset Adjustment of the Picture Level Control Knobs — CONTROL PRESET ADJ Menu

The preliminary adjustment of contrast, brightness, chroma, and phase are carried out with the CONTROL PRESET ADJ menu to set the preset values to the knobs for the above-mentioned adjustments. Preset values can be set either commonly to all channels or separately for individual channels. Preset values can be set in the following ways:

- (1) Adjustment with the MANUAL knobs
- (2) Automatic adjustment (An external color bar signal is necessary.)
- (3) Copying data from other channels, common data, other BVM-series monitors that have been connected via the serial remote connector, or from data stored in monitor memory cards
- (4) Restoring factory settings.

### Structure and Usage of the CONTROL PRESET ADJ Menu

This section explains the setting lists displayed in the menu.

The lists are numbered and shown with indentations to indicate the hierarchy in the menu. If a setting in each list leads to another list or a monitor operation, the list number or the operation is indicated after the ⇒ mark. (Settings without the ⇒ mark end in a single list.)

Select CONTROL PRESET ADJ from the menu list.

```

CONTROL PRESET ADJ... 100
COLOR TEMP ADJ...
SET UP...
MEMORY CARD...
COPY...
STATUS...
MAINTENANCE...
KEY PROTECT OFF
  
```

Menu list

**100** CONTROL PRESET ADJ menu: Select either PRESET or CH SET. ⇒ 101

PRESET...: Set common values.  
CH SET...: Set values for each individual channel.

**101** CONTROL PRESET ADJ (PRESET/xxCH): Select the setting method.

MANUAL...: Set with the MANUAL knobs. ⇒ 110  
AUTO...: Set by automatic adjustment. ⇒ 120  
COPY...: Copy data from elsewhere. ⇒ 130  
RESTORE FACTORY SET: Return values to their factory settings.



## Preset Adjustment of the Picture Level Control Knobs — CONTROL PRESET ADJ Menu

**110 MANUAL (PRESET/xxCH):** Adjust values by turning the PHASE, BRIGHT, CHROMA, and/or CONTRAST knobs.

PHASE: xxxx  
 CHROMA: xxxx  
 BRIGHT: xxxx  
 CONTRAST: xxxx

**120 AUTO (PRESET/xxCH):** Select the color bar signal to be used for automatic adjustment.  
 ⇒ Adjustment is carried out.

FULL FIELD CB 100: 100% full-field color bar  
 FULL FIELD CB 75: 75% full-field color bar  
 SMPTE CB: SMPTE standard color bar  
 EIA CB: EIA standard color bar

**130 COPY (PRESET/xxCH):** Select the source to be copied from.

OTHER VALUE...: Copy data from another channel or from PRESET setting. ⇒ 131  
 OTHER MONITOR...: Copy data from another monitor. ⇒ 133  
 MEMORY CARD...: Copy data from a memory card. ⇒ 136

**131 OTHER VALUE (PRESET/xxCH):** Choose either PRESET or CH SET.  
 ⇒ Copy is carried out.

PRESET: Copy common data.  
 CH SET: Copy data set for another channel. Input the number of the channel from which the data will be copied.

**133 OTHER MONITOR (PRESET/xxCH):** Input the address of the monitor from which the data will be copied. ⇒ 134

MONITOR ADDRESS: Input the address.

**134 OTHER MONITOR (PRESET/xxCH):** Choose either PRESET or CH SET.  
 ⇒ Copy is carried out.

PRESET: Copy common data.  
 CH SET: Copy data set for another channel. Input the number of the channel from which the data will be copied.

**136 MEMORY CARD (PRESET/xxCH):** Select the file name. ⇒ 137

FILE NAME: Select the file name.

**137 FILE NAME (PRESET/xxCH):** Choose either PRESET or CH SET.  
 ⇒ Copy is carried out.

PRESET: Copy common data.  
 CH SET: Copy data set for another channel. Input the number of the channel from which the data will be copied.

## Adjusting the Color Temperature — COLOR TEMP ADJ Menu

The color temperature is adjusted with the COLOR TEMP ADJ menu. The color temperature can be set either commonly to all channels or individually for each channel.

The adjusted value can then be used as an original value.

Color temperature adjustment can be made in the following four ways:

### (1) Knob adjustment

Adjust the color temperature with the bias and gain knobs.

### (2) Automatic adjustment using a probe

Bias and gain can be adjusted automatically by connecting a color analyzer such as the Minolta CA-100.

### (3) Copying other data

Copying data from other channels, common data, other BVM-series monitors that have been connected via the serial remote connector, or from data stored in monitor memory cards

### (4) Restoring factory settings

## Structure and Usage of the COLOR TEMP ADJ Menu

This section explains the setting lists displayed in the menu.

The lists are numbered and shown with indentations to indicate the hierarchy in the menu.

If a setting in each list leads to another list or a monitor operation, the list number or the operation is indicated after the ⇒ mark. (Settings without the ⇒ mark end in a single list.)

Select COLOR TEMP ADJ from the main menu list.

```
CONTROL PRESET ADJ...
COLOR TEMP ADJ... 200
SET UP...
MEMORY CARD...
COPY...
STATUS...
MAINTENANCE...
KEY PROTECT OFF
```

Menu list

**200 COLOR TEMP ADJ menu:** Select STD, COL1, COL2, or CH SET. ⇒ 201

STD: Use common data (factory setting: D65).  
 COL1: Use common data (factory setting: D65).  
 COL2: Use common data (factory setting: D93).  
 CH SET: Use data for each individual channel (factory setting: D65). Use the numeric keypad to select the desired channel.

## Adjusting the Color Temperature — COLOR TEMP ADJ Menu

### 201 COLOR TEMP ADJ (STD/COL1/COL2/xxCH): Select the adjustment method.

**MANUAL...**: Set with the MANUAL knob. ⇒ 210  
**PROBE...**: Set using a probe. ⇒ 220  
**COPY...**: Copy data from elsewhere. ⇒ 260  
**RESTORE FACTORY SET**: Return values to their factory settings.  
**TRIM...**: Perform fine adjustments after setting the color temperature. ⇒ 280

### 210 MANUAL (STD/COL1/COL2/xxCH): Set the following data necessary to perform knob adjustment and select ADJUST.

**ORIGINAL VALUE...**: Set the initial value. ⇒ 211  
**SIGNAL**: Select the white signal to be used for adjustment.  
**INT**: Use an internal signal. Simultaneously with the adjustment of the gain and bias, the 100 IRE and 20 IRE signals are automatically switched.  
**EXT**: Use an external input signal. When adjusting the gain and bias, input the proper signal.  
**ADJUST...**: Perform the adjustment with following knobs. ⇒ 212  
**RED**: CONTRAST knob (Adjust the R gain or bias with the CONTRAST knob.)  
**GREEN**: BRIGHT knob (Adjust the G gain or bias with the BRIGHT knob.)  
**BLUE**: CHROMA knob (Adjust the B gain or bias with the CHROMA knob.)  
**LUMINANCE**: PHASE knob (Adjust luminance with the PHASE knob.)

### 211 ORIGINAL VALUE: Select STD, COL1, COL2, or CH SET. ⇒ 210

**STD**: Use global data (factory setting: D65).  
**COL1**: Use global data (factory setting: D65).  
**COL2**: Use global data (factory setting: D93).  
**CH SET**: Use data for each individual channel (factory setting: D65). Use the numeric keypad to select the desired channel.

### 212 ADJUST (STD/COL1/COL2/xxCH) (1/2): Adjust the gain with the proper knob.

GAIN R:xxxx G:xxxx B:xxxx

### 212 ADJUST (STD/COL1/COL2/xxCH) (2/2): Adjust the bias with the proper knob.

BIAS R:xxxx G:xxxx B:xxxx

### 220 PROBE (STD/COL1/COL2/xxCH): Select the probe. ⇒ 241 (Using a CA-100)

### 241 CA-100 (STD/COL1/COL2/xxCH): Select either D65 or D93, and enter values for LOWLIGHT and HIGHLIGHT. Rather than selecting D65 or D93, you may instead enter the values of the CIE 1931 color system x and y coordinates.

**D65**: Use D65.  
**D93**: Use D93.  
**X**: Enter the x coordinate.  
**Y**: Enter the y coordinate.  
**LOW LIGHT (20IRE)**: Enter the brightness (cd/m<sup>2</sup>) for low light.  
**HIGH LIGHT (100IRE)**: Enter the brightness (cd/m<sup>2</sup>) for high light.  
**START**: Start adjustment. ⇒ 242

### 242 COLOR TEMP ADJ (STD/COL1/COL2/xxCH): Perform adjustment.

**SET PROBE ON CRT**:  
**PRESS ENTER**:  
 Adjustment starts when the probe is placed against the center of the screen and the ENTER button is pressed.

### 260 COPY (STD/COL1/COL2/xxCH): Select the source to be copied from.

**OTHER VALUE...**: Copy data from another channel or from common data. ⇒ 261  
**OTHER MONITOR...**: Copy data from another monitor. ⇒ 263  
**MEMORY CARD...**: Copy data from a memory card. ⇒ 266

### 261 OTHER VALUE (STD/COL1/COL2/xxCH): Select STD, COL1, COL2, or CH SET. ⇒ Copy is carried out.

**STD**: Copy common data (factory setting: D65).  
**COL1**: Copy common data (factory setting: D65).  
**COL2**: Copy common data (factory setting: D93).  
**CH SET**: Copy data from a particular channel (factory setting: D65). Enter the number of the channel from which the data will be copied.

### 263 OTHER MONITOR (STD/COL1/COL2/xxCH): Input the address of the monitor from which the data will be copied.

**MONITOR ADDRESS**: Input the address of the monitor from which the data will be copied. ⇒ 264

### 264 OTHER MONITOR (STD/COL1/COL2/xxCH): Select STD, COL1, COL2, or CH SET. ⇒ Copy is carried out.

**STD**: Copy common data (factory setting: D65).  
**COL1**: Copy common data (factory setting: D65).  
**COL2**: Copy common data (factory setting: D93).  
**CH SET**: Copy data from a particular channel (factory setting: D65). Enter the number of the channel from which the data will be copied.

### 266 MEMORY CARD (STD/COL1/COL2/xxCH): Select the file name. ⇒ 267

### 267 FILE NAME (STD/COL1/COL2/xxCH): Select STD, COL1, COL2, or CH SET. ⇒ Copy is carried out.

**STD**: Copy common data (factory setting: D65).  
**COL1**: Copy common data (factory setting: D65).  
**COL2**: Copy common data (factory setting: D93).  
**CH SET**: Copy data from a particular channel (factory setting: D65). Enter the number of the channel from which the data will be copied.

## Adjusting the Color Temperature — COLOR TEMP ADJ Menu

**280 TRIM (STD/COL1/COL2/xxCH):** After setting the necessary items, select **ADJUST**.

**APPLY/NOT APPLY:** Select whether to add the fine adjustment to the original setting (APPLY) or not (NOT APPLY)

**SIGNAL:** Select the white signal to be used for adjustment.

**INT:** Use an internal signal. Simultaneously with the adjustment of the gain and bias, the 100 IRE and 20 IRE signals are automatically switched.

**EXT:** Use an external input signal. When adjusting the gain and bias, input the proper signal.

**ADJUST...:** Perform the adjustment with following knobs: ⇒ **282**

**RED:** CONTRAST knob (Adjust the R gain or bias with the CONTRAST knob.)

**GREEN:** BRIGHT knob (Adjust the G gain or bias with the BRIGHT knob.)

**BLUE:** CHROMA knob (Adjust the B gain or bias with the CHROMA knob.)

**LUMINANCE:** PHASE knob (Adjust luminance with the PHASE knob.)

**282 ADJUST (STD/COL1/COL2/xxCH) (1/2):** Adjust the gain with the proper knob.

GAIN R:xxxx G:xxxx B:xxxx

**282 ADJUST (STD/COL1/COL2/xxCH) (2/2):** Adjust the bias with the proper knob.

BIAS R:xxxx G:xxxx B:xxxx

## Setting the Input Configuration — INPUT CONFIGURATION Menu

Data pertaining to the input signals are set with the INPUT CONFIGURATION menu.

When a channel number (1 to 90) is entered with the numeric keypad, it is then possible to set which input connector on the rear panel will be assigned to that channel number, and select the type of signal that will be connected. The channel numbers from 91 to 99 are assigned to internal signals.

### Assigning Slot and Connector Numbers

Set which input connector on which slot will be assigned to the current channel. The slots are numbered from the left, as seen when facing the rear panel, with the REMOTE connectors slot being number 1, the input option slots numbers 2 to 5, and the analog input connectors slot being number 6. The connectors are numbered 1 to 6 (from the top) for the slot.

### Assigning the Signal Type and Format

The signal type and format which can be assigned to each channel number vary, depending on what adaptors are installed in the rear panel.

### Assigning serial digital signals

It is possible to assign serial digital signals to the serial digital input connectors on the BKM-20D/21D/22X adaptors. However, at least one BKM-21D which includes the decoder for serial digital signals or BKM-20D which includes the decoder for serial digital component signals must be installed.

### Assigning analog composite signals

It is possible to assign any composite signal to the analog signal input connectors of the BKM-20D/21D/22X, and any of the connectors of the BKM-24N/25P/26M/27T/28X adaptors. However, at least one of the following decoder adaptors must be installed:

**To assign NTSC signals:** BKM-21D/24N/27T

**To assign PAL signals:** BKM-21D/25P/27T

**To assign PAL-M signals:** BKM-26M

**To assign SECAM signals:** BKM-27T

### Assigning Y/C signals

It is possible to assign any Y/C signals to the input connectors of the BKM-24N/25P/26M/27T/28X adaptors. However, at least one of the following decoder adaptors must be installed:

**To assign NTSC signals:** BKM-24N/27T

**To assign PAL signals:** BKM-25P/27T

**To assign PAL-M signals:** BKM-26M

### Assigning analog component or RGB signals

Analog component and RGB signals can be assigned to any input connectors except the serial digital signal input connectors on the BKM-20D/21D/22X.

## Setting the Input Configuration — INPUT CONFIGURATION Menu

### Structure and Usage of the INPUT CONFIGURATION Menu

This section explains the setting lists displayed in the menu.

The lists are numbered and shown with indentations to indicate the hierarchy in the menu.

If a setting in each list leads to another list or a monitor operation, the list number or the operation is indicated after the ⇨ mark. (Settings without the ⇨ mark end in a single list.)

Select SET UP from the main menu list.

```

CONTROL PRESET ADJ...
COLOR TEMP ADJ...
SET UP... ⇨ 300
MEMORY CARD...
COPY...
STATUS...
MAINTENANCE...
KEY PROTECT OFF
  
```

Menu list

**300 SET UP menu list:** Choose the menu for setting the desired items.

**INPUT CONFIGURATION menu:** Set the input signal configuration ⇨ 301

```

REMOTE menu
PASSWORD menu
SYSTEM CONFIGURATION menu
ON SCREEN SET menu
ALIGNMENT menu
  
```

**301 INPUT CONFIGURATION menu (1/2):** Set input signal data for each channel.

**xxCH:** Current channel is indicated. Enter a channel number with the numeric keypad if changing the channel. The settings below will be stored as information about the signal to be connected to this channel.

**FORMAT...:** Select the input signal type. ⇨ 310

**SLOT NO:** Enter the slot number.

**INPUT NO:** Enter the input connector number.

**YC SEP...:** Select a Y/C separation filter. ⇨ 315

**SYNC MODE:** Select the sync signal.

**INT:** Use an internal sync signal.

**EXT:** Use an external sync signal.

**SCREEN MODE...:** Select the scan size. ⇨ 320

**SAFE AREA:** Choose whether or not to display the safe area (OFF or ON).

**SAFE AREA SCALE...:** Select the safe area size. ⇨ 322

**APERTURE:** Choose whether or not to use aperture adjustment (OFF or ON).

**APERTURE VALUE:** Enter the aperture adjustment value (0 to 200).

**301 INPUT CONFIGURATION menu (2/2):** Set input signal data for each channel.

**xxCH:** Current channel is indicated. Enter a channel number with the numeric keypad if changing the channel. The settings below will be stored as information about the signal to be connected to this channel.

**FILTER:** Switch the filter operation (OFF or ON) when the monochrome display is selected.

**CHANNEL NAME...:** Give the channel a name. ⇨ 326

**CONTROL:** Select whether to use local ("CH SET") or common ("PRESET") values for contrast, brightness, chroma, and phase.

**PRESET:** Use common data.

**CH SET:** Use values set for each channel.

**COLOR TEMP...:** Set the color temperature. ⇨ 328

**H PHASE:** Set the horizontal picture position (0 to 200).

**COPY...:** Select a method for copying data from elsewhere. ⇨ 330

**310 FORMAT (xxCH):** Select the signal format.

#### Note

If there is no input connector or decoder corresponding to a format, that format will not be selectable (the cursor will skip over that item).

**COMPOSITE...:** Composite signal. ⇨ 311

**YC...:** Y/C signal. ⇨ 311

**COMPONENT...:** Component or RGB signal. ⇨ 312

**SDI...:** Serial digital signal. ⇨ 313

**311 COMPOSITE (xxCH):** Select the format of a composite or Y/C signal.

#### Notes

- Even when selecting AUTO, also select the NTSC, PAL, or PAL-M format.
- If there is no input connector or decoder corresponding to a format, that format will not be selectable (the cursor will skip over that entry).

**AUTO:** The format of the input signal is detected and switched automatically.

**NTSC:** SETUP 7.5 or 0.

**PAL:** S (simple) or D (delay).

**PAL-M:** S (simple) or D (delay).

**SECAM**

**312 COMPONENT (xxCH):** Select the component signal format, or RGB.

**YUV SMPTE/EBU-N10**

**YUV BETACAM:** SETUP 7.5 or 0.

**RGB**

**313 SDI (xxCH):** Select the format of the serial digital signal.

**AUTO:** The format of the input signal is detected and switched automatically.

**NTSC:** SETUP 7.5 or 0

**PAL:** S (simple) or D (delay)

**4:2:2**

## Setting the Input Configuration — INPUT CONFIGURATION Menu

**315 YC SEP (xxCH):** Select a Y/C separation filter.

TRAP/BPF  
2 LINES COMB  
3 LINES COMB

**320 SCREEN MODE (xxCH):** Select the scan size.

4:3-NORM: Overscanned 4:3 aspect ratio.  
4:3-UNDR: Underscanned 4:3 aspect ratio.  
16:9-NORM: Overscanned 16:9 aspect ratio.  
16:9-UNDR: Underscanned 16:9 aspect ratio.

**322 SAFE AREA (xxCH):** Select the type of screen. ⇒ 323

4:3 OR 16:9: Display the screen and safe area in 4:3 or 16:9 aspect ratio.  
16:9 IN 4:3: Display a 16:9 aspect ratio safe area in a 4:3 aspect ratio screen.  
4:3 IN 16:9: Display a 4:3 aspect ratio safe area in a 16:9 aspect ratio screen.

**323 4:3 OR 16:9 (xxCH):** Select the size of the safe area.

80 %  
90 %  
100 %

**326 CHANNEL NAME (xxCH):** Give the channel a name. Select a preset name, or enter a new one.

PROG: Program signal.  
EDIT: Signal from an editor.  
CAM: Camera signal.  
VTR: Signal from a VTR.  
NEW NAME: Enter a new name. (Up to 20 characters can be entered and up to six characters from the head of the name are displayed in the INPUT CONFIGURATION menu (301, 2/2).)

**328 COLOR TEMP (xxCH):** Select STD, COL1, COL2, or CH SET.

STD: Use common data (factory setting: D65).  
COL1: Use common data (factory setting: D65).  
COL2: Use common data (factory setting: D93).  
CH SET: Use data for the current channel (factory setting: D65).

**330 COPY (xxCH):** Select the source to be copied from.

OTHER CH: Copy data from another channel. Enter the channel number.  
OTHER MONITOR...: Copy data from another monitor. ⇒ 332  
MEMORY CARD...: Copy data from a memory card. ⇒ 334

**332 OTHER MONITOR (xxCH):** Enter the address of the monitor from which to copy data.

MONITOR ADDRESS: Enter the address of the monitor from which to copy data. ⇒ 333

**333 OTHER MONITOR (xxCH):** Select which channel of the chosen monitor from which to copy data. ⇒ Copy is carried out.

CH NO: Enter the channel number.

**334 MEMORY CARD (xxCH):** Select the file name. ⇒ 335

**335 MEMORY CARD (xxCH):** Select which channel of the chosen file from which to copy data. ⇒ Copy is carried out.

CH NO: Enter the channel number.

## Assigning the Remote Control Functions — REMOTE Menu

The remote control functions are set with the REMOTE menu. With this monitor, both serial remote control (REMOTE 1) and parallel remote control (REMOTE 2) are possible. It is possible to simultaneously use the BKM-10R, REMOTE 1, and REMOTE 2 for control, but commands from REMOTE 2 have priority. Therefore, it is impossible for the BKM-10R or REMOTE 1 to change items set by REMOTE 2.

There is no priority order between commands from REMOTE 1 and the BKM-10R; it is possible to set APERTURE to ON from REMOTE 1 and then set it to OFF with a control panel operation.

### About Monitor Address and Group Numbers

The monitor control unit BKM-10R or the integrated control unit monitors BVM-14E5E/14E5U/14F5E/14F5U are able to control up to 32 monitors connected via serial remote connector (using the REMOTE 1 connector). By giving each monitor a monitor address and group number, it is possible to control just a specific monitor or monitor group.

With the REMOTE menu, each monitor can be set with a monitor address and group number, between 1 and 99. The ADDRESS menu is used to select a particular monitor or group by entering a monitor number or group number.

*For information about the ADDRESS menu, see "Selecting the Monitor to Control —ADDRESS Menu".*

### Structure and Usage of the REMOTE Menu

This section explains the setting lists displayed in the menu.

The lists are numbered and shown with indentations to indicate the hierarchy in the menu.

If a setting in each list leads to another list or a monitor operation, the list number or the operation is indicated after the ⇒ mark. (Settings without the ⇒ mark end in a single list.)

Select SET UP from the menu list.

CONTROL PRESET ADJ...
COLOR TEMP ADJ...
SET UP... ⇒ 300
MEMORY CARD...
COPY...
STATUS...
MAINTENANCE...
KEY PROTECT OFF

Menu list

**300 SET UP menu list:** Choose the menu for setting the desired items.

INPUT CONFIGURATION menu
REMOTE menu: Set the remote control functionality ⇒ 340
PASSWORD menu
SYSTEM CONFIGURATION menu
ON SCREEN SET menu
ALIGNMENT menu

**340 REMOTE menu:** Select the type of remote control.

PARA REMOTE: Select whether or not parallel remote control will be used (ON or OFF).
PARA REMOTE CONFIG...: Set the pin assignments for the REMOTE2 (parallel remote control) connector. ⇒ 341
SERI REMOTE CONFIG...: Set the address and group number of the monitor controlled via the REMOTE 1 (serial remote control) connector. ⇒ 343

## Assigning the Remote Control Functions — REMOTE Menu

**341 PARA REMOTE CONFIG:** Select the REMOTE 2 connector pins for which you want to change the function. The factory settings for each pin are given below. ⇨ **342**

1 PIN...: CH01  
 2 PIN...: CH02  
 3 PIN...: EXT SYNC  
 4 PIN...: MONO  
 5 PIN...: SAFE AREA  
 6 PIN...: unused  
 7 PIN...: unused  
 8 PIN...: TALLY

**342 1-8 PIN (1/2):** Assign a function to the selected pin.

**CH:** Select a channel number. Enter the desired channel number with the numeric keypad.  
 ---: Set to unused.  
**UNDERSCAN:** Set underscan on or off.  
**16:9:** Set a 16:9 aspect ratio on or off.  
**H DELAY:** Set the horizontal sync display on or off.  
**V DELAY:** Set the vertical sync display on or off.  
**EXT SYNC:** Set the synchronization to external sync signals enabled or disabled.  
**COMB:** Set the comb filter on or off.  
**APERTURE:** Set the correction of frequency characteristics enabled or disabled.  
**MONO:** Set monochrome display on or off.

**342 1-8 PIN (2/2):** Assign a function to the selected pin.

**BLUE ONLY:** Set the blue signal pictures display (monochrome) on or off.  
**R OFF:** Set cutting red beams enabled or disabled.  
**G OFF:** Set cutting green beams enabled or disabled.  
**B OFF:** Set cutting blue beams enabled or disabled.  
**VITC ON:** Set the VITC display on or off.  
**SAFE AREA ON:** Set the safe area display on or off.  
**CAPTION VISION:** Set the caption vision on or off.  
**TALLY ON:** Set tally signals on or off.  
**DEGAUSS ON:** Set degaussing on or off.  
**POWER ON:** Set the monitor power on or off.

*For information about pin connections, see the description of the REMOTE 2 connector in "Location and Function of Parts" on page 10.*

**343 SERI REMOTE CONFIG:** Set the monitor address and group number of the monitor currently connected directly to the control unit. The monitors to be assigned addresses and group numbers must be directly connected to the control unit and set one at a time.

**MONITOR ADDRESS:** Enter a number.  
**GROUP ADDRESS:** Enter a number.

## Setting the Password — PASSWORD Menu

A four-digit password can be specified and applied to desired menu options to prohibit the menu settings from being changed without permission. The password is set with the PASSWORD menu. A password is always assigned to the PASSWORD menu (factory setting: 9999). When a new password is created, it is automatically applied to the PASSWORD menu.

**If the password is not entered correctly**  
 If an incorrect password is entered, or if nothing is entered within about five seconds from when the message is displayed, the message "INCORRECT ENTRY" is displayed, and the menu disappears from the screen.

### Use of the Password

The message "PLEASE ENTER PASSWORD" is displayed when an attempt is made to select a menu item for which the password has been applied. The correct password must be entered with the numeric keypad within about five seconds.

### Structure and Usage of the PASSWORD Menu

This section explains the setting lists displayed in the menu.

The lists are numbered and shown with indentations to indicate the hierarchy in the menu. If a setting in each list leads to another list or a monitor operation, the list number or the operation is indicated after the ⇨ mark. (Settings without the ⇨ mark end in a single list.)

Select SET UP from the menu list.

CONTROL PRESET ADJ...
COLOR TEMP ADJ...
SET UP... ⇨ 300
MEMORY CARD...
COPY...
STATUS...
MAINTENANCE...
KEY PROTECT OFF

Menu list

**300 SET UP menu list:** Choose the menu for setting the desired items.

INPUT CONFIGURATION menu
REMOTE menu
PASSWORD menu: Set the password ⇨ 400
SYSTEM CONFIGURATION menu
ON SCREEN SET menu
ALIGNMENT menu

## Setting the Password — PASSWORD Menu

**400 PASSWORD menu:** Enter the password for the PASSWORD menu.

**ENTER PASSWORD:** Enter the password (factory setting: 9999). ⇨ **401**

**401 PASSWORD:** Choose what action to perform with the password.

**CHANGE PASSWORD...:** Change the password. ⇨ **402**

**APPLY PASSWORD...:** Assign the password to a menu item. ⇨ **404**

**402 ENTER NEW PASSWORD:** Create a new password.

**ENTER NEW PASSWORD:** Enter a password. ⇨ **403**

**403 CHANGE PASSWORD:** Change the password.

**RE-ENTER PASSWORD  
TO CONFIRM**

Enter the new password again and press the ENTER button. ⇨ **The password is recorded.**

To change it, press the MENU button. ⇨ **Return to the PASSWORD (401).**

**404 APPLY PASSWORD:** Choose whether or not to apply the password to each menu.

**CONTROL PRESET ADJ:** YES or NO.

**CONTROL TEMP ADJ:** YES or NO.

**SET UP:** YES or NO.

**MEMORY CARD:** YES or NO.

## Setting the Channel Selection Method and Power-Up Conditions — SYSTEM CONFIGURATION Menu

The SYSTEM CONFIGURATION menu is used for the following settings:

**(1) Channel number entry method**

The two ways in which the ten-key pad can be used to enter channel numbers are as follows:

(In the explanation below, x and y represent any digit between 1 and 9.)

**DIRECT mode:** When selecting a number from 1 to 9, press the x button to display channel x. When selecting a number from 10 to 99, press the 0, x, and y buttons to display channel xy (a two-digit channel number). This mode is selected at the shipping.

**10KEY mode:** When the x button is pressed followed by the ENTER button, the monitor displays channel x. When the x buttons is pressed, followed by the y and ENTER buttons, the monitor displays channel xy (a two-digit channel number).

When multiple monitors are connected by a serial remote connection, this setting will be common to all the monitors. It is not possible to change the setting for individual monitors.

**(2) Power-up condition**

This menu sets the condition of the monitor when the main power switch on the rear panel is switched on.

**ON:** Standby mode

**OFF:** Operation mode

**(3) Power-up input channel**

**LAST:** Set the channel to the channel that was selected at the time the power was last turned off.

**CH xx:** Set the channel to a specific channel number.

**(4) Time from power-up until degauss**

If several monitors are turned on at the same time and all start degaussing at the same time, there will be a very large current draw on the power supply for a few moments. To prevent this, the delay time between power-up and degaussing can be set for each monitor independently.

**(5) AFC time constant**

**(6) Residual subcarrier detection (when using the BKM-24N/25P)**

It is possible to detect residual subcarrier signals from phase change by setting the adaptor's residual subcarrier switch on.

**(7) Auto chroma control (ACC) (when using the BKM-27T)**



## Setting the Channel Selection Method and Power-Up Conditions — SYSTEM CONFIGURATION Menu

### Structure and Usage of the SYSTEM CONFIGURATION Menu

This section explains the setting lists displayed in the menu.

The lists are numbered and shown with indentations to indicate the hierarchy in the menu.

If a setting in each list leads to another list or a monitor operation, the list number or the operation is indicated after the ⇨ mark. (Settings without the ⇨ mark end in a single list.)

Select SET UP from the menu list.

```
CONTROL PRESET ADJ...
COLOR TEMP ADJ...
SET UP... ⇨ 300
MEMORY CARD...
COPY...
STATUS...
MAINTENANCE...
KEY PROTECT OFF
```

Menu list

**300 SET UP menu list:** Choose the menu for setting the desired items.

```
INPUT CONFIGURATION menu
REMOTE menu
PASSWORD menu
SYSTEM CONFIGURATION menu: Set the channel selection method and power up conditions ⇨ 500
ON SCREEN SET menu
ALIGNMENT menu
```

**500 SYSTEM CONFIGURATION menu:** Set each of the various items.

```
INPUT SELECT: Select the channel number selection method (DIRECT or 10KEY).
STANDBY MODE: Select the power-up condition (OFF or ON).
DEFAULT CH: Select the power-up input channel (LAST or CH xx).
DEGAUSS DELAY: Set the time between power-up and the beginning of degaussing. Enter the
desired time (in seconds).
AFC TIME: Select the AFC time constant (0.5 or 2 ms).
RESIDUAL SC SW (BKM-24N): Switch the residual switch on the BKM-24N (OFF or ON).
RESIDUAL SC SW (BKM-25P): Switch the residual switch on the BKM-25P (OFF or ON).
ACC SW (BKM-27T): Switch the ACC switch on the BKM-27T (OFF or ON).
```

## Setting the Screen Display — ON SCREEN SET Menu

The ON SCREEN SET menu is used to select the type of information that will be displayed on the screen and how that information will be displayed. The types of information that can be set are given below.

(1) **The VITC or user bit from the input signal**

(2) **EDH (Error Detection and Handling) information (when using the BKM-20D/21D)**

EDH is an error detection system which inserts Error Status Packets (ESP) into the serial digital signal. Using the data in these packets, it is possible to detect transmission errors.

With EDH, errors in the SDI signal's three data fields (Ancillary Data, Active Picture Data, and Full Field Data) can be detected, using five types of error flag (EDH, EDA, IDH, IDA, and UES). The flags make a distinction between errors caused by a certain device (EDH, IDH) and those that were caused earlier by some other equipment connected to that device (EDA/IDA).

**EDH (Error Detected Here):** Indicates the occurrence of a transmission error.

**EDA (Error Detected Already):** Indicates the occurrence of a transmission error.

**IDH (Internal Device Error Here):** Indicates the occurrence of a non-transmission error.

**IDA (Internal Device Error Already):** Indicates the occurrence of a non-transmission error.

**UES (Unknown Error Status):** Indicates the occurrence of a different error.

When an EDH error occurs in the signal being displayed by the monitor, the message "EDH ERROR" is displayed on the screen. The details of the error can be confirmed with the error flags mentioned above, which are displayed in the menus. The menus can also be used to confirm whether or not the signal accommodates EDH.

The following two modes can be used to display the status in the menus:

**ANALYZE MODE:** Preserve the status when it is displayed.

**WATCH MODE:** Check status in real time.

(3) **Caption vision**

(4) **SDI signal ancillary data blanking (when using the BKM-20D/21D)**

(5) **Channel number and name**

## Setting the Screen Display — ON SCREEN SET Menu

### Structure and Usage of the ON SCREEN SET Menu

This section explains the setting lists displayed in the menu.

The lists are numbered and shown with indentations to indicate the hierarchy in the menu.

If a setting in each list leads to another list or a monitor operation, the list number or the operation is indicated after the ⇒ mark. (Settings without the ⇒ mark end in a single list.)

Select SET UP from the menu list.

```
CONTROL PRESET ADJ...
COLOR TEMP ADJ...
SET UP... ⇒ 300
MEMORY CARD...
COPY...
STATUS...
MAINTENANCE...
KEY PROTECT OFF
```

Menu list

**300 SET UP menu list:** Choose the menu for setting the desired items.

```
INPUT CONFIGURATION menu
REMOTE menu
PASSWORD menu
SYSTEM CONFIGURATION menu
ON SCREEN SET menu: Set the screen display ⇒ 600
ALIGNMENT menu
```

**600 ON SCREEN SET menu:** Select items to be displayed on the screen.

```
VITC...: Select whether or not to display the VITC or user bit data contained in the input signal. ⇒
601
EDH...: Select whether or not to display the EDH error messages. ⇒ 610
CAPTION VISION...: Select whether or not to display the caption, and select the display mode. ⇒
620
ANCILLARY DATA: Select whether or not to display the ancillary data in the serial digital signal
(OFF or ON).
CH NO...: Select the display mode of the channel number. ⇒ 625
CH NAME...: Select the display mode of the channel name. ⇒ 625
VITC POSITION...: Select the display position for the VITC data. ⇒ 630
EDH POSITION...: Select the display position for the EDH error messages. ⇒ 630
CH NO POSITION...: Select the display position for the channel number. ⇒ 630
CH NAME POSITION...: Select the display position for the channel name. ⇒ 630
```

**601 VITC:** Select whether or not to display the VITC and/or user bit.

```
VITC: OFF or ON
USER BIT: OFF or ON
```

**610 EDH:** Select whether or not to display the EDH error messages. If they are to be displayed, select either ANALYZE MODE or WATCH MODE.

```
ERROR WARNING: OFF or ON
ANALYZE MODE: ⇒ 611
WATCH MODE: ⇒ 615
```

**611 ANALYZE MODE:** Detection results for each item is displayed. Select the items for which you want to see the flag conditions.

```
EDH: The result whether the input signal accommodates EDH (FOUND) or not (INVALID)
ACTIVE PICT: Results will be displayed (ERROR or NO ERROR) ⇒ 612
FULL FIELD: Results will be displayed (ERROR or NO ERROR) ⇒ 613
ANCI DATA: Results will be displayed (ERROR or NO ERROR) ⇒ 614
```

**612 ACTIVE PICT:** Flag condition is displayed.

```
AP EDH: ERROR or NO ERROR
AP EDA: ERROR or NO ERROR
AP IDH: ERROR or NO ERROR
AP IDA: ERROR or NO ERROR
AP UES: ERROR or NO ERROR
```

**613 FULL FIELD:** Flag condition is displayed.

```
FF EDH: ERROR or NO ERROR
FF EDA: ERROR or NO ERROR
FF IDH: ERROR or NO ERROR
FF IDA: ERROR or NO ERROR
FF UES: ERROR or NO ERROR
```

**614 ANCI DATA:** Flag condition is displayed.

```
ANC EDH: ERROR or NO ERROR
ANC EDA: ERROR or NO ERROR
ANC IDH: ERROR or NO ERROR
ANC IDA: ERROR or NO ERROR
ANC UES: ERROR or NO ERROR
```

## Setting the Screen Display — ON SCREEN SET Menu

**615 WATCH MODE:** Detection results for each item is displayed. Select the items for which you want to see the flag conditions.

**EDH:** The result whether the input signal accommodates EDH (FOUND) or not (INVALID)  
**ACTIVE PICT:** Results will be displayed (ERROR or NOERROR). ⇒ **616**  
**FULL FIELD:** Results will be displayed (ERROR or NOERROR). ⇒ **617**  
**ANCI DATA:** Results will be displayed (ERROR or NO ERROR) ⇒ **618**

**616 ACTIVE PICT:** Flag condition is displayed.

**AP EDH:** ERROR or NO ERROR  
**AP EDA:** ERROR or NO ERROR  
**AP IDH:** ERROR or NO ERROR  
**AP IDA:** ERROR or NO ERROR  
**AP UES:** ERROR or NO ERROR

**617 FULL FIELD:** Flag condition is displayed.

**FF EDH:** ERROR or NO ERROR  
**FF EDA:** ERROR or NO ERROR  
**FF IDH:** ERROR or NO ERROR  
**FF IDA:** ERROR or NO ERROR  
**FF UES:** ERROR or NO ERROR

**618 ANCI DATA:** Flag condition is displayed.

**ANC EDH:** ERROR or NO ERROR  
**ANC EDA:** ERROR or NO ERROR  
**ANC IDH:** ERROR or NO ERROR  
**ANC IDA:** ERROR or NO ERROR  
**ANC UES:** ERROR or NO ERROR

**620 CAPTION VISION:** Select the caption display mode.

**CAPTION 1**  
**CAPTION 2**  
**TEXT 1**  
**TEXT 2**  
**OFF**

**625 CH NO or CH NAME:** Select the channel number and channel name display mode.

**AUTO:** Disappear after displayed for a while.  
**ON:** Displayed.  
**OFF:** Not displayed.

**630 POSITION:** Select the display position.

**TL:** Top left  
**TC:** Top center  
**TR:** Top right  
**BL:** Bottom left  
**BC:** Bottom center  
**BR:** Bottom right

## Convergence Adjustments — ALIGNMENT Menu

The ALIGNMENT menu is used for adjusting convergence and geometry.

### Structure and Usage of the ALIGNMENT Menu

This section explains the setting lists displayed in the menu.

The lists are numbered and shown with indentations to indicate the hierarchy in the menu.

If a setting in each list leads to another list or a monitor operation, the list number or the operation is indicated after the ⇒ mark. (Settings without the ⇒ mark end in a single list.)

Select SET UP from the menu list.

```
CONTROL PRESET ADJ...
COLOR TEMP ADJ...
SET UP... ⇒ 300
MEMORY CARD...
COPY...
STATUS...
MAINTENANCE...
KEY PROTECT OFF
```

Menu list

**300 SET UP menu list:** Choose the menu for setting the desired items.

```
INPUT CONFIGURATION menu
REMOTE menu
PASSWORD menu
SYSTEM CONFIGURATION menu
ON SCREEN SET menu
ALIGNMENT menu: Perform convergence and geometry adjustment ⇒ 700
```

**700 ALIGNMENT menu (1/2):** Adjust each item with the UP and DOWN buttons or PHASE knob, or return to factory settings.

```
FACTORY SET: Return values to their factory settings.
ROTATION: Compensates for the screen rotation which occurs when the monitor is installed facing north or south.
H CENTER: Adjust the horizontal picture position.
V CENTER: Adjust the vertical picture position
H SIZE: Adjust the width of the picture.
V SIZE: Adjust the height of the picture.
V BLANKING: Adjust the vertical blanking of the screen.
H PIN: Correct the side pincushion distortion.
H KEY: Correct the trapezoid distortion.
```

**700 ALIGNMENT menu (2/2):** Adjust each item with the UP and DOWN buttons or PHASE knob, or return to factory settings.

```
H STATIC CONV: Adjust the horizontal static convergence.
V STATIC CONV: Adjust the vertical static convergence.
```

## Monitor Memory Card Data Operations — MEMORY CARD Menu

Operations on monitor memory card data are performed with the MEMORY CARD menu.

*On how to handle the monitor memory card, refer to the operation manual for the control unit or the built-in control unit monitor.*

### Structure and Usage of the MEMORY CARD Menu

This section explains the setting lists displayed in the menu.

The lists are numbered and shown with indentations to indicate the hierarchy in the menu.

If a setting in each list leads to another list or a monitor operation, the list number or the operation is indicated after the ⇒ mark. (Settings without the ⇒ mark end in a single list.)

Select MEMORY CARD from the menu list.

```
CONTROL PRESET ADJ...
COLOR TEMP ADJ...
SET UP...
MEMORY CARD... ⇒ 800
COPY...
STATUS...
MAINTENANCE...
KEY PROTECT OFF
```

Menu list

**800 MEMORY CARD menu:** Select the operation to perform.

**SAVE:** Write data to a monitor memory card. ⇒ **801**  
**LOAD:** Read data from a monitor memory card. ⇒ **803**  
**FORMAT:** Format a monitor memory card. ⇒ **805**

**801 SAVE:** Select the name of the file to which to write data, or create a new file name. ⇒ **802**

**NEW NAME:** Enter a new name (max. 20 characters).

**802 SELECTED OR CREATED FILE NAME:** Confirm the data write.

**OVERWRITE THIS FILE?**  
**OK: ENTER KEY**  
**CANCEL: MENU KEY**  
To overwrite the file, press ENTER. ⇒ **The data write is performed.**  
To cancel the write, press MENU. ⇒ **Return to the SAVE (801).**

**803 LOAD:** Select the name of the file from which to read data. ⇒ **804**

**804 SELECTED FILE NAME:** Select the data to read.

**ALL:** Read data for all menu settings.  
**CONTROL PRESET:** Read the data for the CONTROL PRESET ADJ menu settings.  
**COLOR TEMP:** Read the data for the COLOR TEMP ADJ menu settings.  
**SET UP:** Read the data for the SET UP menu settings.

**805 FORMAT:** Confirm the format operation.

**ALL FILES WILL BE DELETED!**  
**ARE YOU SURE?**  
**OK: ENTER KEY**  
**CANCEL: MENU KEY**  
To continue, press the ENTER button. ⇒ **The format is performed.**  
To cancel, press the MENU button. ⇒ **Return to the MEMORY CARD menu (800).**

## Monitor-to-Monitor Data Copy — COPY Menu

When multiple monitors are connected via their serial remote ports, data can be shared between the monitors by data copy. The data copy from one monitor to another is accomplished with the COPY menu.

### Structure and Usage of the COPY Menu

This section explains the setting lists displayed in the menu.

The lists are numbered and shown with indentations to indicate the hierarchy in the menu.

If a setting in each list leads to another list or a monitor operation, the list number or the operation is indicated after the ⇨ mark. (Settings without the ⇨ mark end in a single list.)

Select COPY from the menu list.

```
CONTROL PRESET ADJ...
COLOR TEMP ADJ...
SET UP...
MEMORY CARD...
COPY... : 850
STATUS...
MAINTENANCE...
KEY PROTECT OFF
```

Menu list

**850 COPY menu:** Select the copy source monitor.

**MONITOR ADDRESS:** Enter the address number. ⇨ **851**

**851 COPY:** Select the data to be copied. ⇨ **Copy is carried out.**

**ALL:** Copy data for all menu settings.  
**CONTROL PRESET:** Copy the data for the CONTROL PRESET ADJ menu settings.  
**COLOR TEMP:** Copy the data for the COLOR TEMP menu settings.  
**SET UP:** Copy the data for the SET UP menu settings.

## Displaying Information About the Monitor — STATUS Menu

The STATUS menu is used to view general data about the monitor and information about signals assigned to the slots in the rear panel.

### Structure and Usage of the STATUS Menu

This section explains the setting lists displayed in the menu.

The lists are numbered and shown with indentations to indicate the hierarchy in the menu.

If a setting in each list leads to another list or a monitor operation, the list number or the operation is indicated after the ⇨ mark. (Settings without the ⇨ mark end in a single list.)

Select STATUS from the menu list.

```
CONTROL PRESET ADJ...
COLOR TEMP ADJ...
SET UP...
MEMORY CARD...
COPY...
STATUS... : 900
MAINTENANCE...
KEY PROTECT OFF
```

Menu list

**900 STATUS menu (1/3):** Data about the current channel is displayed.

**CH:** channel number  
**SL:** slot number  
**IN:** input connector number  
**FORMAT:** format of the input signal  
**NAME:** channel name

**900 STATUS menu (2/3):** Data about the monitor is displayed.

**MODEL NAME:** model name  
**SERIAL NO:** serial number  
**OPERATION TIME:** operation time (in hours)  
**SOFTWARE VERSION:** software version

## Displaying Information About the Monitor — STATUS Menu

**900 STATUS menu (3/3):** Data about signals assigned to each slot in the rear panel is displayed.

SLOT1  
SLOT2  
SLOT3  
SLOT4  
SLOT5  
SLOT6  
SLOT7  
SLOT8  
SLOT9

## Selecting the Monitor to Control — ADDRESS Menu

When multiple monitors are connected by a serial remote connection, they can be controlled with a monitor control unit BKM-10R or a built-in control unit monitor, such as the BVM-14E5E/14E5U/14F5E/14F5U. The ADDRESS menu is used to choose whether one particular monitor or monitor group will be controlled, or whether operations are to be performed on all monitors together.

### Structure and Usage of the ADDRESS Menu

Press the ADDRESS button on the control panel of the BKM-10R or the BVM-14E5E/14E5U/14F5E/14F5U.

The ADDRESS button lights, and the ADDRESS menu is displayed on the screen.

```
ADDRESS
SINGLE **
GROUP **
ALL
ALL POWER ON
ALL POWER OFF
```

ADDRESS menu

The settings for each of the items are as follows:

**SINGLE:** Control only a particular monitor. Enter the address (32 of the numbers from 01 to 99 may be selected).

**GROUP:** Control only a particular monitor group. Enter the group number (32 of the numbers from 01 to 99 may be selected).

**ALL:** Control all monitors.

**ALL POWER ON:** When this is selected, all connected monitors will be turned on.

**ALL POWER OFF:** When this is selected, all connected monitors will be turned off.

### To exit the ADDRESS menu

Press the ADDRESS button.

# Specifications

## General

System	525 lines, 60 fields per second interlaced 625 lines, 50 fields per second interlaced
CRT	Super fine pitch Trinitron <b>BVM-20E1E/20E1U/20F1E/20F1U</b> Aperture grille pitch: 0.3 mm, (BVM-20F1E/20F1U) Aperture grille pitch: 0.25 mm, (BVM-20E1E/20E1U) 90 degree deflection, 30.6 mm diameter in-line gun. Effective picture size: 386 × 291 mm (15 1/4 × 11 1/2 inches) (w/h) 482 mm (19 inches) (diagonal size) CRT protection: EHT (extremely high tension) protection type Warm-up time: approx. 30 minutes Anode voltage: 27 kV with no beam current Nominal chromaticity coordinates:
	SMPTE phosphor (BVM-20E1U/20F1U)
	EBU phosphor (BVM-20E1E/20F1E)
	<b>BVM-41E1E/14E1U/14E5E/14E5U/14F1E/14F1U/14F5E/14F5U</b> Aperture grille pitch: 0.25 mm (BVM-14F1E/14F1U/14F5E/14F5U) Aperture grille pitch: 0.22 mm (BVM-14E1E/14E1U/14E5E/14E5U) 90-degree deflection, 29.4 mm diameter in-line gun.

Effective picture size:  
268 × 201 mm (10 5/8 × 8 inches) (w/h)  
332 mm (13 1/8 inches) (diagonal size)  
CRT protection: EHT (extremely high tension) protection type  
Warm-up time: approx. 30 minutes  
Anode voltage: 25 kV with no beam current  
Nominal chromaticity coordinates:

SMPTE phosphor (BVM-14E1U/14E5U/14F1U/14F5U)

	x	y
R	0.630	0.340
G	0.310	0.595
B	0.155	0.070

EBU phosphor (BVM-14E1E/14E5E/14F1E/14F5E)

	x	y
R	0.640	0.330
G	0.290	0.600
B	0.150	0.060

## Power requirements

100 to 240 V AC, ±10%, 50/60 Hz

## Power consumption

**BVM-20E1E/20E1U/20F1E/20F1U:** 120 W

**BVM-14E1E/14E1U/14E5E/14E5U/14F1E/14F1U/14F5E/14F5U:** 110 W

## Dimensions

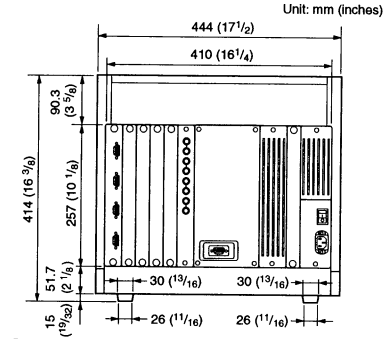
**BVM-20E1E/20E1U/20F1E/20F1U:** 444 × 414 × 570 mm (17 1/2 × 16 3/8 × 22 1/2 inches) (w/h/d)

**BVM-14E5E/14E5U/14F5E/14F5U:** 482 × 280 × 580 mm (19 × 11 1/8 × 20 7/8 inches) (w/h/d)

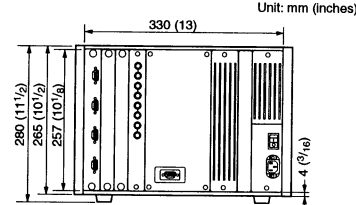
**BVM-14E1E/14E1U/14F1E/14F1U:** 346 × 280 × 530 mm (13 5/8 × 11 1/8 × 20 7/8 inches) (w/h/d)

## Dimensional drawing

**BVM-20E1E/20E1U/20F1E/20F1U**



**BVM-14E1E/14E1U/14F1E/14F1U**



## Mass

**BVM-20E1E/20E1U/20F1E/20F1U:** approx. 37 kg (81 lb 9 oz)

**BVM-14E5E/14E5U/14F5E/14F5U:** approx. 25 kg (55 lb 1 oz)

**BVM-14E1E/14E1U/14F1E/14F1U:** approx. 22 kg (48 lb 8 oz)

## Input/output Connectors

**Video input** BNC type, 3 (with three loop-through outputs)  
R/G/B: 1 Vp-p ±6 dB, positive, high impedance  
Y: 1 Vp-p ±6 dB, positive, high impedance  
R-Y/B-Y: 0.7 Vp-p ±6 dB, positive, high impedance

**Sync input** BNC type, 1 (with loop-through output)  
Composite sync: 0.3 to 8 Vp-p, negative, high impedance

**Return loss** More than 46 dB (7 MHz, with 75-ohm termination)

**Remote control** OPTION  
Mini-DIN 8-pin, 1  
CONTROL UNIT  
D-sub 9-pin, 1  
REMOTE 1  
D-sub 9-pin, 1 (with loop-through output), RS-485 serial interface  
REMOTE 2  
D-sub 9-pin, 1 (with loop-through output)  
ISR  
D-sub 9-pin, 1

## Video Signal

**Differential gain** Less than 2% (for luminance from 0 to 100 cd/m<sup>2</sup>)

**Differential phase** Less than 2° (for luminance from 0 to 100 cd/m<sup>2</sup>)

**Frequency response** 100 Hz to 10 MHz, ±1 dB

**DC restoration** Back porch type  
Black level fluctuation: less than 1% for 10 to 90% APL input signal variation.

## Synchronization

**AFC time Constant** 0.5 ms (fast mode)  
2 ms (normal mode)

**Line pull range/line hold range** Greater than ±500 Hz (with 0.5 ms AFC time constant)

**Vertical blanking time** Normal: less than 1 ms.  
Underscan: less than 0.8 ms

**Horizontal blanking time** Less than 10 μs



## Specifications

---

### Picture Performance

Normal scan	5% overscan of CRT effective screen area (adjustable range greater than $\pm 15\%$ )
Underscan	3% underscan of CRT effective screen area (adjustable range greater than $\pm 15\%$ )
Linearity	Within a central area bounded by a circle with a diameter equal to the picture height, less than 0.5% of the picture height, and outside the same area, about 1% of the picture height
Color temperature	D65, D93 (adjustable to other color temperatures)
Convergence error	Within a central area bounded by a circle with a diameter equal to the picture height: Less than 0.4 mm (BVM-20E1E/20E1U/20F1E/20F1U) Less than 0.3 mm (14E1E/14E1U/14E5E/14E5U/14F1E/14F1U/14E5E/14F5U) Outer area of the above-mentioned circle: Less than 0.7 mm (BVM-20E1E/20E1U/20F1E/20F1U) Less than 0.6 mm (BVM-14E1E/14E1U/14E5E/14E5U/14F1E/14F1U/14F5E/14F5U)
Standard luminescence	100 cd/m <sup>2</sup> (at standard 1 Vp-p 100% white signal)
Raster size stability	Less than 1% of picture height (at 100 cd/m <sup>2</sup> peak luminescence, 10 to 90% APL)
Scan delay	Horizontal: Approx. $\frac{1}{4}$ line Vertical: Approx. $\frac{1}{2}$ field
Resolution (at screen center, 100 cd/m <sup>2</sup> luminescence)	BVM-14E1E/14E1U/14E5E/14E5U: 900 TV lines BVM-14F1E/14F1U/14F5E/14E5U: 800 TV lines BVM-20E1E/20E1U: 1000 TV lines BVM-20F1E/20F1U: 900 TV lines

### Environmental Conditions

Operating temperature	0°C to 40°C (32°C to 104°F)
Optimum operating temperature	20°C to 30°C (68°F to 86°F)
Operating humidity	0% to 90% (no condensation)

### Accessories Supplied

AC power cord (1)
Cord stopper (1)
Tally plate (1)
Operation manual (1)
Fuse (2)
Design and specifications are subject to change without notice.

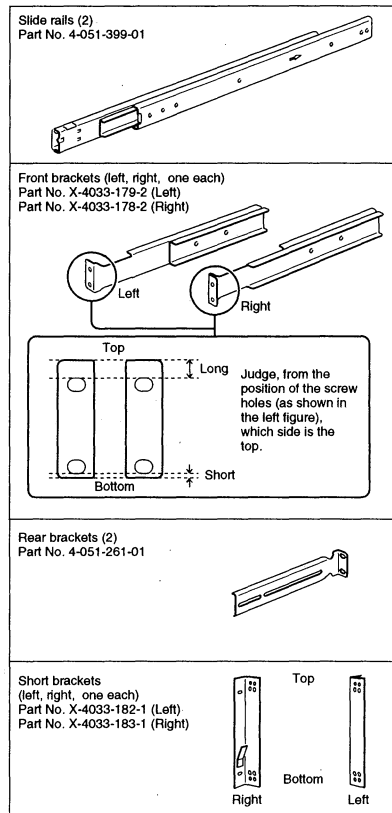
# • BKM-30E20

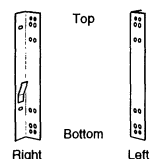




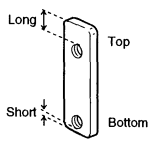


## Overview

The BKM-30E20 Rack Mount Kit is a rack mount kit for mounting a Sony BVM series 20-inch monitor in an EIA standard 19-inch rack.

### Components

The BKM-30E20 consists of the following components. Check to make sure that you have all the components before beginning assembly.



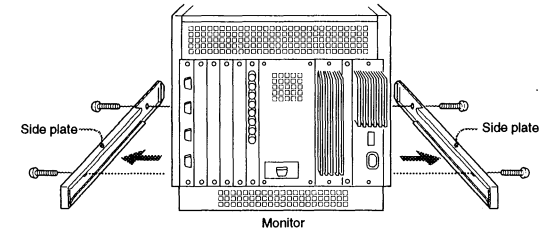
Long brackets (left, right, one each) Part No. X-4033-181-1 (Left) Part No. X-4033-180-1 (Right)	
Screws A (4 × 10 mm, silver) (16) Part No. 7-682-562-04	
Screws B (4 × 12 mm, black) (4) Part No. 7-682-263-09	
Screws C (4 × 16 mm silver) (8) Part No. 7-682-565-04	
Nuts (8) Part No. 7-684-024-04	
Plate nuts (4) Part No. 4-051-259-01	
Plain washers (φ4) (16) Part No. 7-688-004-01	
Spring washers (φ4) (12) Part No. 7-623-210-22	

## Assembly

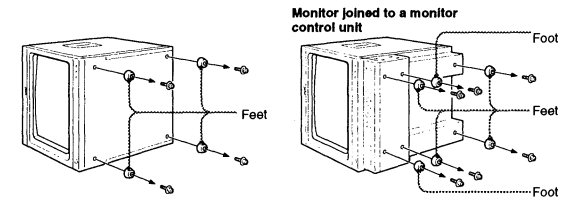
- 1 Remove the left and right side plates from the bottom part of the monitor.

**For a monitor joined to a monitor control unit**  
Attach the short side covers for rack mounting to the monitor and the monitor control unit.

See step 11 of "Assembly" in the *Installation Manual for the BKM-32H Monitor Control Unit Attachment Kit* on how to attach them.



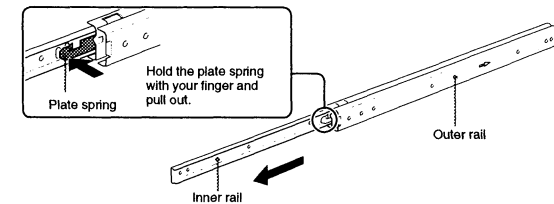
- 2 Remove the four feet from the bottom of the monitor (six feet if the monitor is joined to a monitor control unit).



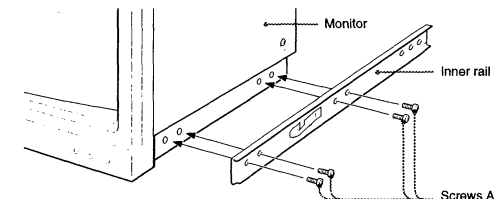
- 3 Separate the inner rail of the slide rail from the outer rail.

**Note**

Take care not to get your fingers caught in the slide rail.



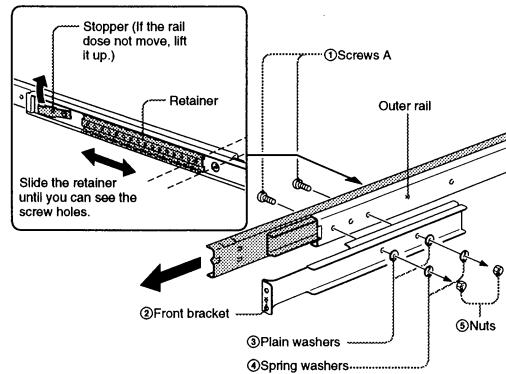
- 4 Attach the inner rail to the monitor using four screws A (4 × 10 mm).



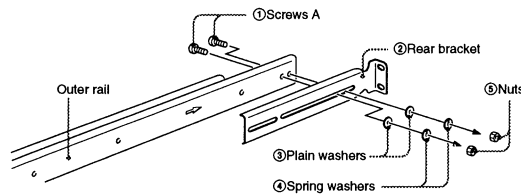
(continued)

## Assembly

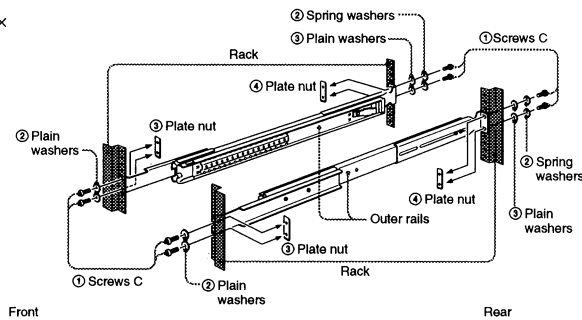
- 5** Attach the front bracket to the outer rail using two screws A (4 × 10 mm), two plain washers (φ4), two spring washers (φ4), and two nuts.



- 6** Attach the rear bracket to the outer rail using two screws A (4 × 10 mm).



- 7** Attach the outer rails to the rack using four screws A (4 × 10 mm) for each rail.



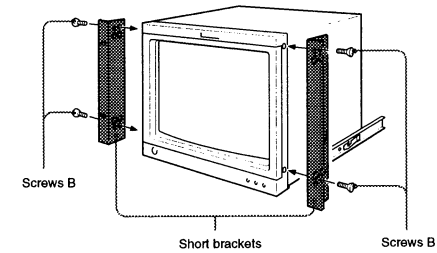
- 8** Attach the short brackets (or long brackets if the monitor is joined to a monitor control unit) to the monitor using two screws B (4 × 12 mm) for each bracket.

### For a monitor joined to a monitor control unit

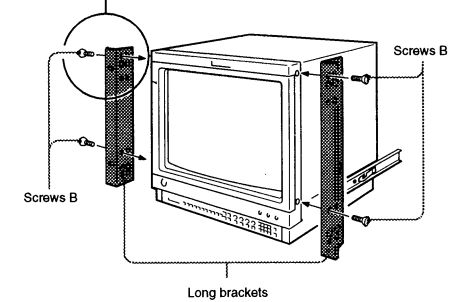
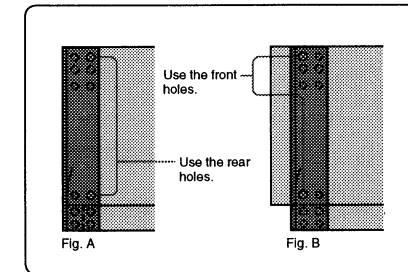
Select the front or rear screw holes of the long brackets.

- To mount the monitor so that it fits exactly inside the rack, use the screw holes at the rear of the long brackets (see Fig. A).

- To mount the monitor so that it protrudes slightly from the rack, use the screw holes at the front of the long brackets (see Fig. B). In this case, the monitor control unit is even with the front of the rack.



Monitor joined to a monitor control unit (side view)



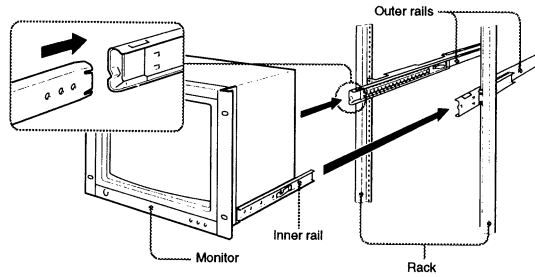
(continued)

## Assembly

### 9 Attach the monitor to the rack.

**Note**

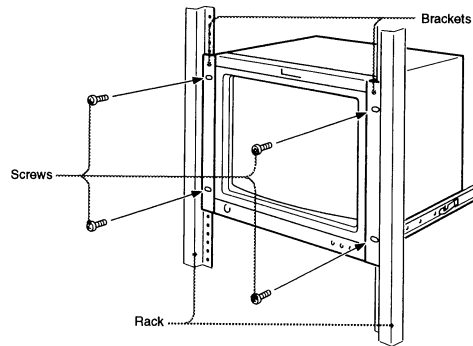
Push the monitor all the way into the rack, without releasing your grip until you hear an audible click as the plate springs of the slide rails are fixed in place. Unless they are fixed in place, there is a danger that the monitor might fall out of the rack.



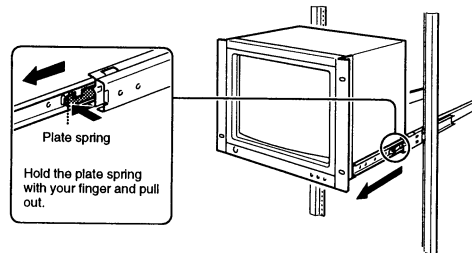
### 10 Using the four oval holes in the brackets, screw the monitor to the rack. Use screws appropriate for the rack's screw holes.

**Note**

When you are tightening the screws, the plate spring works to push the monitor toward the front of the rack. Always ask someone to assist you when you mount the monitor. One person should tighten the screws while the other person holds the monitor in place with both hands.



### Removing the Monitor From the Rack



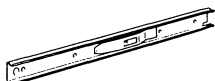
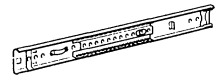
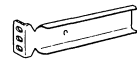
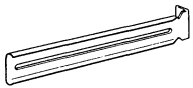
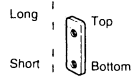




# • BKM-30E14

## Overview

The BKM-30E14 is a rack mount kit for mounting a Sony BVM series 14-inch stand-alone monitor in an EIA standard 19-inch rack.

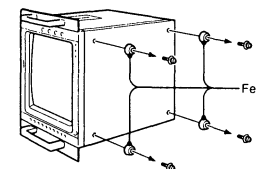
### Components

The BKM-30E14 consists of the following components. Check to make sure that you have all the components before beginning assembly. The circled letters A to I in the table below correspond to those in the illustrations on the subsequent pages.

Part	Qty	Part no.
Ⓐ Rail A 	2	2-378-217-02 (Shipped with rail A inserted in rail B.)
Ⓑ Rail B 	2	
Ⓒ Front bracket 	2	4-051-611-01
Ⓓ Rear bracket 	2	4-051-612-01
Ⓔ Plate nut Judge, from the position of the screw holes (as shown in the figure), which side is the top. 	4	4-051-259-01
Ⓕ Screw ⓄM4x6 	4	7-682-160-01
Ⓖ Screw ⓄPSW4x20 	8	7-682-966-01
Ⓗ Screw ⓄM4x10 	4	7-682-162-01
Ⓘ Flange nut M4 	4	4-304-749-01

## Assembly

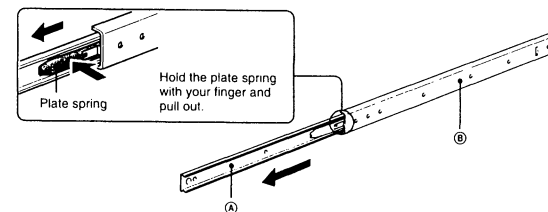
- 1 Remove the four feet from the bottom of the monitor.



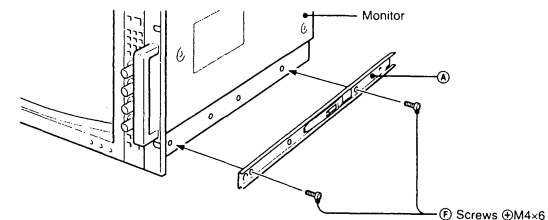
- 2 Pull out rail A from rail B.

**Note**

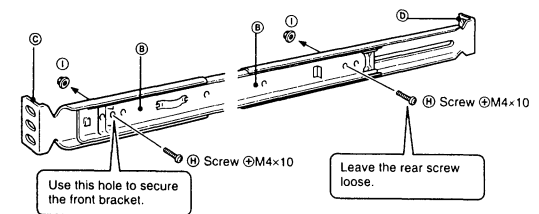
Take care not to get your fingers caught between the rails.



- 3 Attach rail A to the monitor.



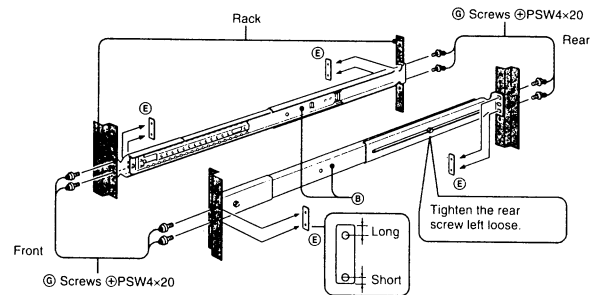
- 4 Attach the front bracket and rear bracket to rail B.



(continued)

## Assembly

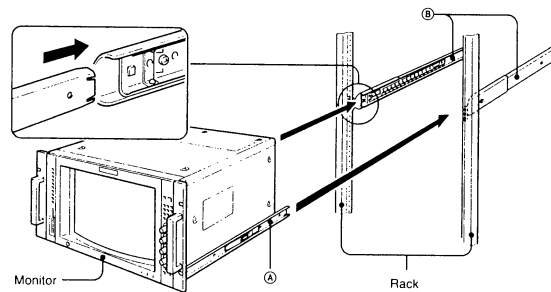
- 5 Attach rails B to the rack.



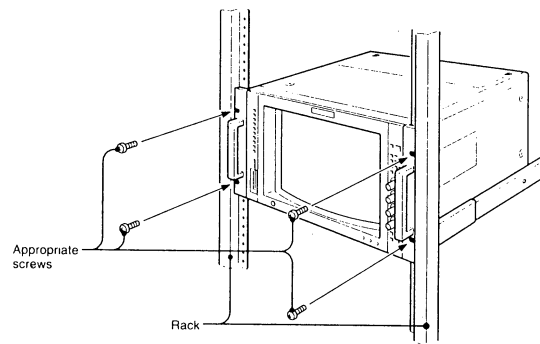
- 6 Insert rails A attached to the monitor into rails B.

**Note.**

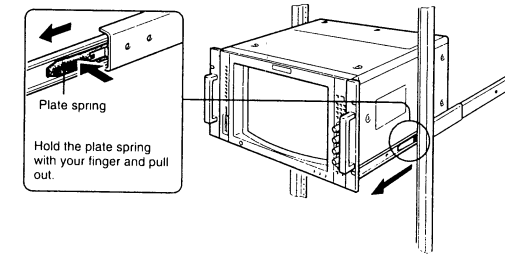
Push the monitor all the way into the rack, without releasing your grip until you hear an audible click as the plate springs of rails A are fixed in place. Unless they are fixed in place, there is a danger that the monitor might fall out of the rack.



- 7 Using screws appropriate for the rack's screw holes, secure the monitor to the rack.



## Removing the monitor from the rack



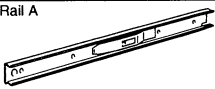
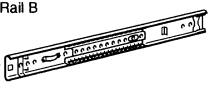
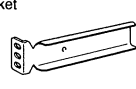

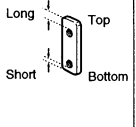



# • BKM-31E14



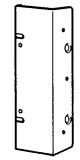




## Overview

The BKM-31E14 is a rack mount kit for mounting a Sony BVM series 14-inch monitors (BVM-14F1/14E1 series) in an EIA standard 19-inch rack.

## Components

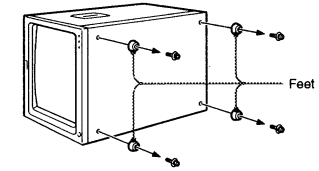
The BKM-31E14 consists of the following components. Check to make sure that you have all the components before beginning assembly. The circled letters (A) to (H) in the table below correspond to those in the illustrations on the subsequent pages.

Part	Qty	Part no.
(A) Rail A 	2	2-378-217-02 (Shipped with rail A inserted in rail B.)
(B) Rail B 	2	
(C) Front bracket 	2	4-051-611-01
(D) Rear bracket 	2	4-051-612-01
(E) Plate nut Judge, from the position of the screw holes (as shown in the figure), which side is the top. 	4	4-051-259-01
(F) Screw ⊕PSW4x8 	16	7-682-961-01
(G) Screw ⊕PSW4x20 	8	7-682-966-01
(H) Screw ⊕M4x10 	8	7-682-162-01

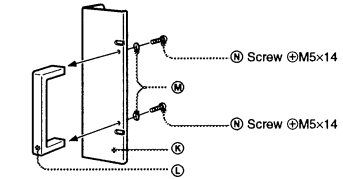
Part	Qty	Part no.
(I) Flange nut M4 	4	4-304-749-01
(J) Bracket 	4	4-052-059-01
(K) Wide flange 	2	4-052-060-01
(L) Handle 	2	4-337-212-12
(M) Spring washer 	4	7-623-212-22
(N) Screw ⊕M5x14 	4	7-682-177-01
(O) Screw ⊕PSW4x12 	6	7-682-963-09

## Assembly

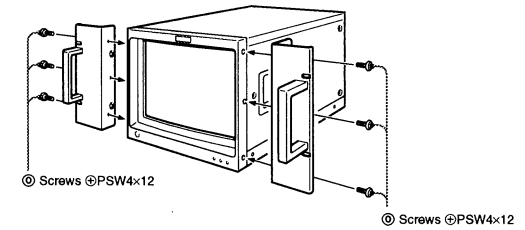
- 1** Remove the four feet from the bottom of the monitor.



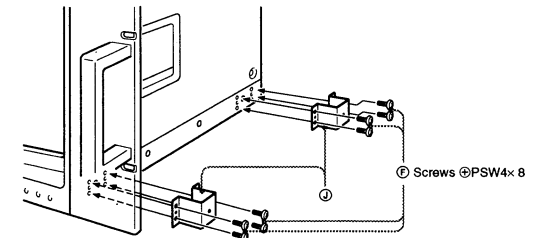
- 2** Attach the handle to the wide flange.



- 3** Attach the wide flanges to the monitor.



- 4** Attach the brackets to the monitor.



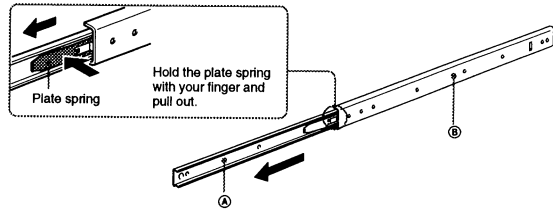
(continued)

**Assembly**

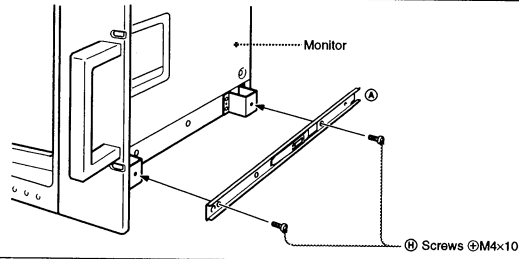
**5** Pull out rail A from rail B.

**Note**

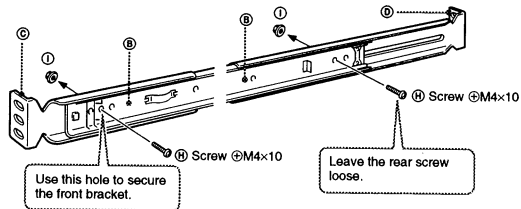
Take care not to get your fingers caught between the rails.



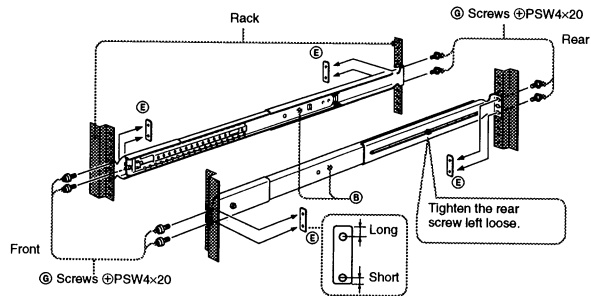
**6** Attach rail A to the monitor.



**7** Attach the front bracket and rear bracket to rail B.



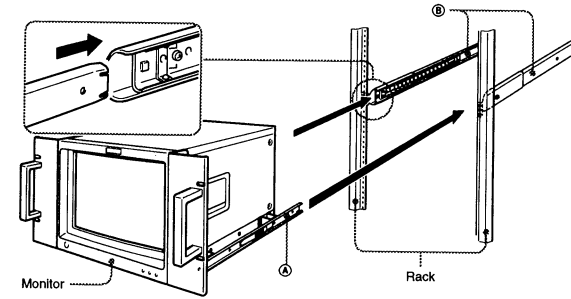
**8** Attach rails B to the rack.



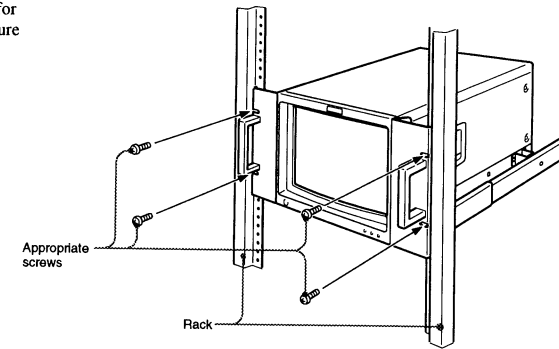
**9** Insert rails A attached to the monitor into rails B.

**Note**

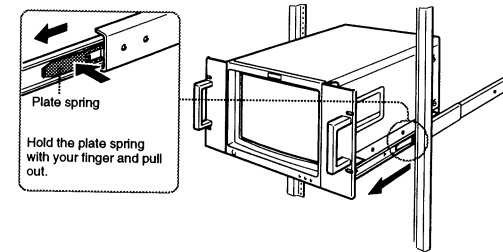
Push the monitor all the way into the rack, without releasing your grip until you hear an audible click as the plate springs of rails A are fixed in place. Unless they are fixed in place, there is a danger that the monitor might fall out of the rack.



**10** Using screws appropriate for the rack's screw holes, secure the monitor to the rack.



**Removing the monitor from the rack**





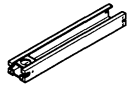

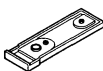

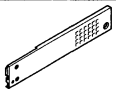
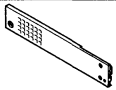
# • BKM-32H










## Overview

The BKM-32H Monitor Control Unit Attachment Kit is an assembly kit for joining a Sony BVM series 20-inch monitor to a BKM-10R Monitor Control Unit.

### Components

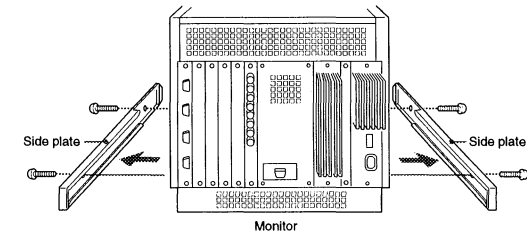
The BKM-32H consists of the following components. Check to make sure that you have all the components before beginning assembly.

Base frames (2) Part No. 4-051-257-01	
Stay (1) Part No. 4-051-256-02	
Inner plates (2) Part No. 4-051-095-01	
Bushing (1) Part No. 4-364-745-01	
Long side cover (right) (1) Part No. 4-051-254-01	
Long side cover (left) (1) Part No. 4-051-255-01	

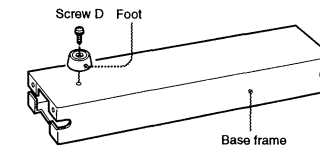
Short side cover (right) (1) Part No. 4-051-252-01	
Short side cover (left) (1) Part No. 4-051-253-01	
Joint covers (2) Part No. 4-051-251-01	
Feet (2) Part No. X-4033-117-1	
Screws A (4x20 mm, silver) (4) Part No. 7-682-566-04	
Screws B (4x8 mm, silver) (4) Part No. 3-703-354-41	
Screws C (4x8 mm, black) (6) Part No. 7-682-561-09	
Screws D (PS 4x16 mm, silver) (2) Part No. 7-682-665-09	
9-pin remote control cable (1) Part No. 1-558-883-11	

## Assembly

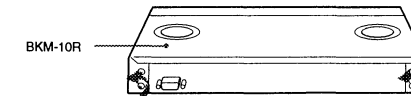
- 1 Remove the left and right side plates from the bottom part of the monitor.



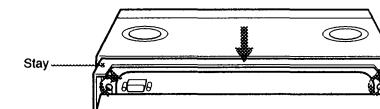
- 2 Attach the feet to the undersides of the two base frames using screws D (PS 4 x 16 mm).



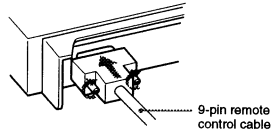
- 3 There are four screws at the rear of the BKM-10R. Loosen the two underside screws.



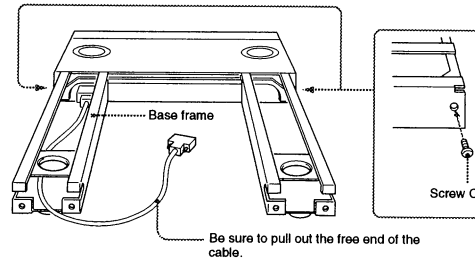
- 4 Attach the stay to the rear of the BKM-10R. (Place the two cut-outs in the stay on the two loosened underside screws at the rear of the BKM-10R, fitting the heads of the two topside screws in the round holes in the stay, then tighten the underside screws.)



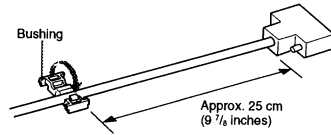
- 5** Connect one end of the supplied 9-pin remote control cable to the DISPLAY UNIT connector at the rear of the BKM-10R.



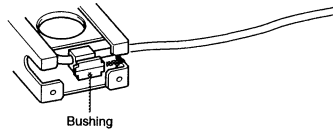
- 6** Assemble the base frames to the two ends of the stay, then screw them together using screws C (4 × 8 mm, black).



- 7** Fasten a bushing approx. 25 cm (9 7/8 inches) from the free end of the cable pulled out through the base frame in step 6.



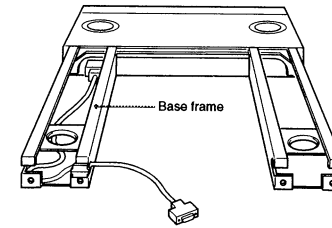
- 8** Press the bushing into the inner side cut-out in the end of the base frame.



(Continued)

## Assembly

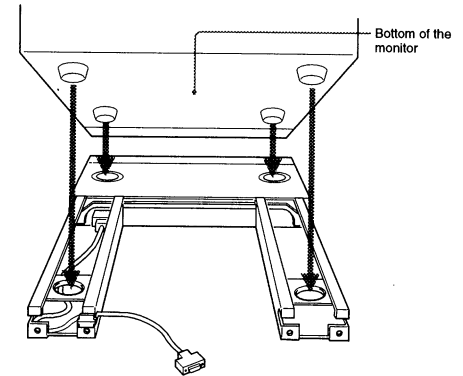
- 9** Press the cable into the base frame (as shown in the figure) so that it is not pushed out of the base frame.



- 10** Place the monitor on the BKM-10R so that the four feet of the monitor go into the two indentations on the upper surface of the BKM-10R and the two round holes in the topsides of the base frames.

**Note**

Before proceeding to the next step, check to be sure that the feet of the monitor are seated in the round indentations and round holes, as shown in the figure.

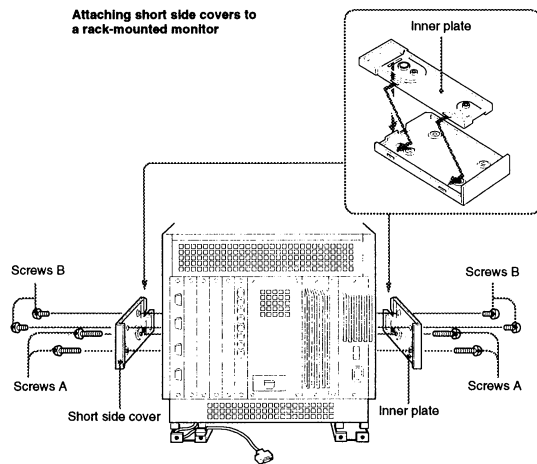
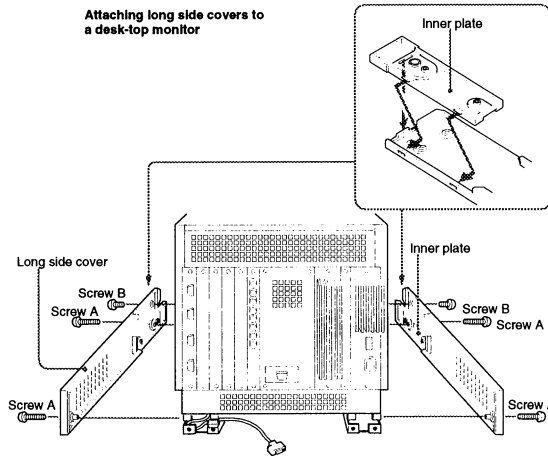


**11** Attach the inner plates to the respective side covers, then screw them to the bottom part of the monitor and the BKM-10R sides. Use screws A ( $4 \times 20$  mm) and screws B ( $4 \times 8$  mm, silver) as shown in the figures.

- Use long side covers for desk-top monitors.
- Use short side covers for rack-mounted monitors.

**Note**

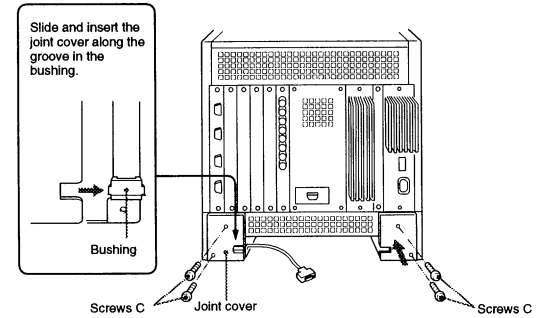
Be sure to attach the both side covers properly to join the monitor and the BKM-10R firmly.



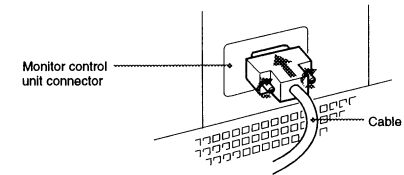
(Continued)

**Assembly**

**12** Attach the joint covers and screw them in place. Use two screws C ( $4 \times 8$  mm, black) for each cover.



**13** Connect the cable to the monitor control unit connector at the rear of the monitor, and fasten the screws of the cable connector.



**• BKM-10R****WARNING**

**To prevent fire or shock hazard, do not expose the unit to rain or moisture.**

**To avoid electrical shock, do not open the cabinet. Refer servicing to qualified personnel only.**



This symbol is intended to alert the user to the presence of important operating and maintenance (servicing) instructions in the literature accompanying the appliance.

**For customers in the USA**

This equipment has been tested and found to comply with the limits for a Class A digital device, pursuant to Part 15 of the FCC Rules. These limits are designed to provide reasonable protection against harmful interference when the equipment is operated in a commercial environment. This equipment generates, uses, and can radiate radio frequency energy and, if not installed and used in accordance with the instruction manual, may cause harmful interference to radio communications. Operation of this equipment in a residential area is likely to cause harmful interference in which case the user will be required to correct the interference at his own expense.

You are cautioned that any changes or modifications not expressly approved in this manual could void your authority to operate this equipment.

The shielded interface cable recommended in this manual must be used with this equipment in order to comply with the limits for a digital device pursuant to Subpart B of Part 15 of FCC Rules.

**For customers in Canada**

This Class A digital apparatus meets all requirements of the Canadian Interference-Causing Equipment Regulations.

**Pour les utilisateurs au Canada**

Cet appareil numérique de la classe A respecte toutes les exigences du Règlement sur le matériel brouilleur du Canada.

**Für Kunden in Deutschland**

Dieses Produkt kann im kommerziellen und in begrenztem Maße auch im industriellen Bereich eingesetzt werden. Dies ist eine Einrichtung, welche die Funk-Entstörung nach Klasse B besitzt.

## Overview

The BKM-10R Monitor Control Unit is a control unit for Sony BVM-series color video monitors. Use it to power monitors on and off, perform menu operations, and carry out monitor setup and adjustment.

### Controlling monitor groups

You can control up to 32 monitors from the BKM-10R. First, using the monitor menus, assign an address number to each monitor, divide the monitors into groups, and assign a group number to each group. Then you can use the BKM-10R to control individual monitors or monitor groups simply by entering monitor address or group numbers. You can also execute the same operation on all connected monitors, or use the BKM-10R to put all connected monitors into the same setup and adjustment state.

### Setup and adjustment with the monitor memory card

You can use an optional BKM-12Y Monitor Memory Card to save and load monitor setup and adjustment data. If your system includes more than one monitor, you can use the monitor memory cards to exchange data between monitors. This makes it easy to put all monitors in your system into the same setup and adjustment state.

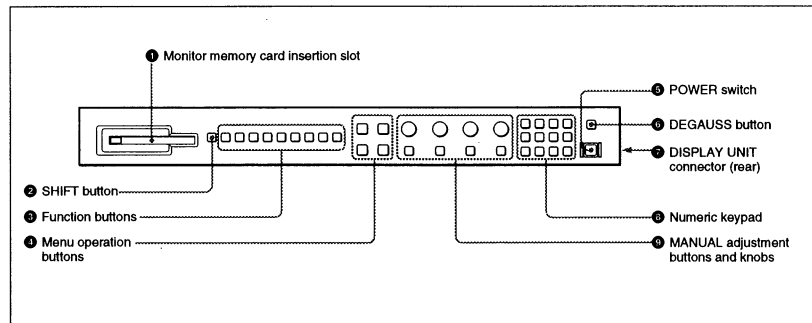
### Attach to 20-inch monitors

You can use an optional BKM-32H Monitor Control Unit Attachment Kit to attach the BKM-10R to the BVM-20F1U/20F1E and other BVM-series color video monitors.

### Rack Mounting

You can use an supplied rack mount attachment screws and an optional MB-510 Rack Mount Kit to mount the BKM-10R in an EIA standard 19-inch rack.

## Location and Function of Parts



**1 Monitor memory card insertion slot**  
Insert an optional BKM-12Y Monitor Memory Card.

### 2 SHIFT button

Each of the Function buttons (3) has a Shift On function as well as a Shift Off function. Press this button to select Shift On or Shift Off functions. Each time you press this button, its orange LED lights (Shift On) or goes out (Shift Off).

**Shift On:** Use the function indicated below the Function button.

**Shift Off:** Use the function indicated above the Function button.

### 3 Function buttons

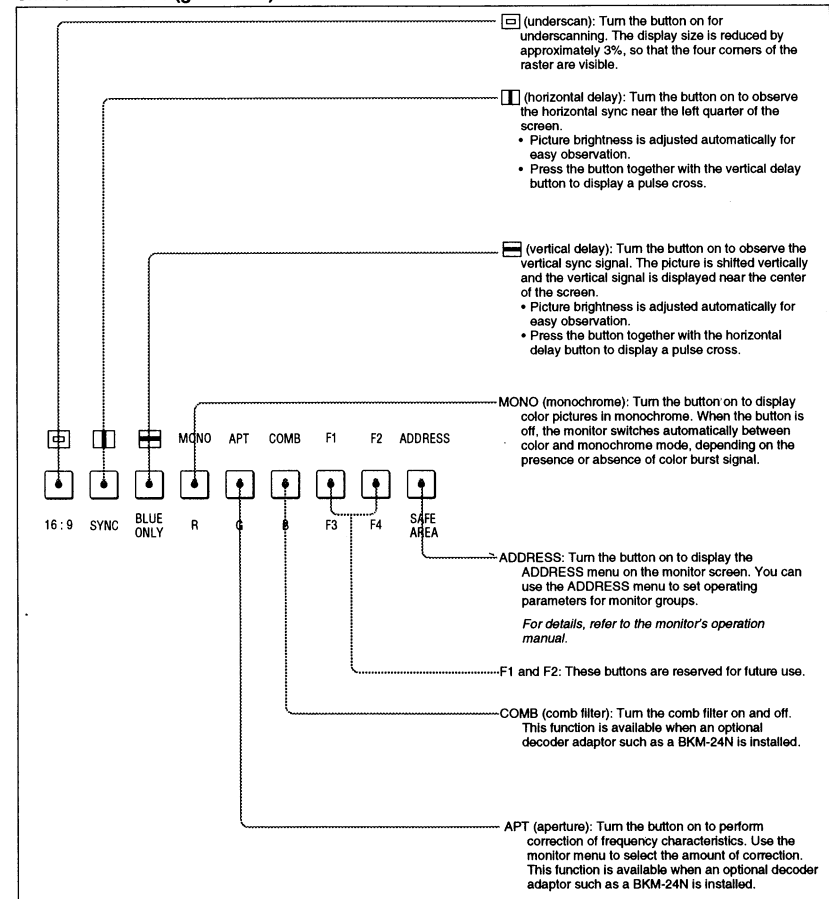
Use these buttons to control the operation of the monitor.

Each of these buttons has a Shift On function, indicated below the button, as well as a Shift Off function, indicated above the button. Press the SHIFT button (2) to select the desired function.

Each time you press one of these buttons, its LED lights or goes out and the function of the button selected with the SHIFT button (2) is turned on or off. The LED color change whether you select Shift Off functions or Shift On functions.

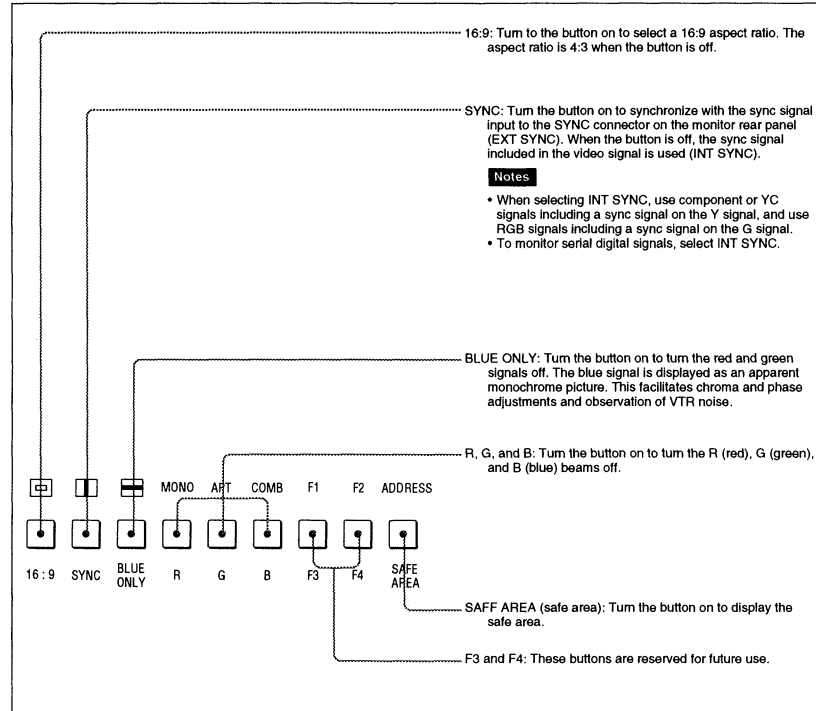
**For Shift Off functions:** Green LED  
**For Shift On functions:** Orange LED

### Shift Off functions (green LED)

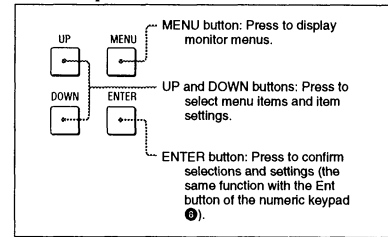


**Location and Function of Parts**

**Shift On functions (orange LED)**



**4 Menu operation buttons**



For more information about using monitor menus, refer to the monitor's operation manual.

**5 POWER switch**

Press to power the monitor on or off. If your system includes more than one monitor, you can use the ADDRESS menu to power all monitors on or off at once.

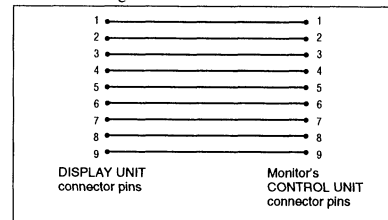
For information about the ADDRESS menu, refer to the monitor's operation manual.

**6 DEGAUSS button**

Press to manually degauss the monitor CRT. When degaussing repeatedly, wait for 5 minutes before pressing the button again. (The monitor CRT is degaussed automatically each time the power is turned on.)

**7 DISPLAY UNIT connector (rear)**

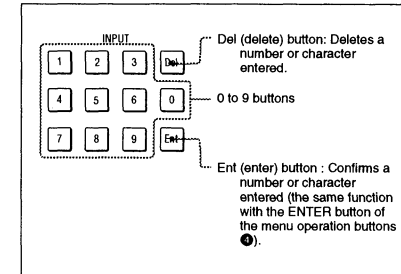
Connect to the CONTROL UNIT connector of a monitor designed for use with a separate control panel such as a BVM-20F1U/20F1E/14F1U/14F1E, using a straight cable with D-sub 9-pin plugs (not supplied) as shown in the figure below.



This connector is used to exchange control signals and to supply power from the monitor to the BKM-10R.

**8 Numeric keypad**

Use the numeric keypad to enter menu settings and channel numbers for signals that you want to input to the monitor.



**9 MANUAL adjustment buttons and knobs**

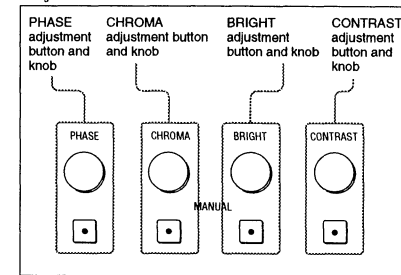
Each press of one of these buttons turns the button's green LED on or off. When the corresponding button is on (lit), you can rotate the knobs to adjust the picture's contrast, brightness (black level), chroma, and phase. These buttons are also used to enter adjustment values from the menus.

You can use the CONTROL PRESET ADJ menu to set preset values for each adjustment item.

For information about the CONTROL PRESET ADJ menu, refer to the monitor's operation manual.

**Notes on using a SECAM, PAL D, component, and component digital system**

- The phase of component signals cannot be adjusted.
- The phase and chroma of RGB signals cannot be adjusted.

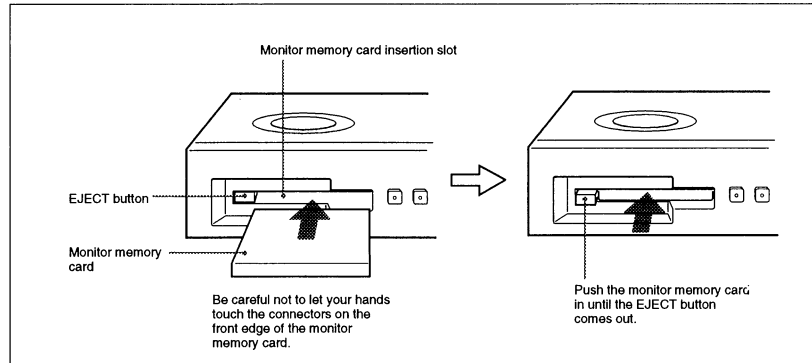


## Inserting and Ejecting the Monitor Memory Card

Proceed as follows to insert and eject an optional BKM-12Y Monitor Memory Card.

*For information about using data on the monitor memory card, refer to the monitor's operation manual.*

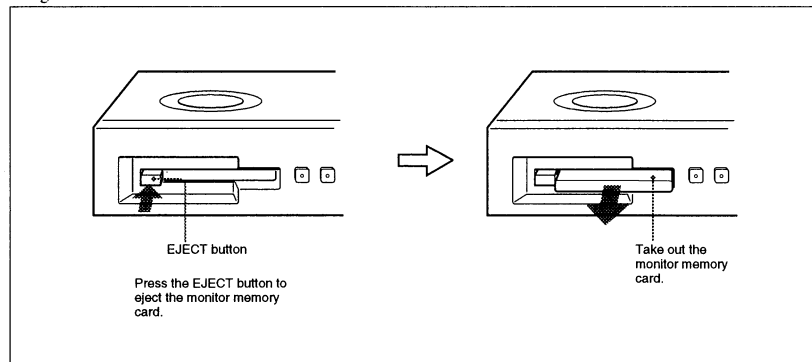
### Inserting the monitor memory card



### Ejecting the monitor memory card

#### Note

Do not eject the monitor memory card while data is being saved or loaded.



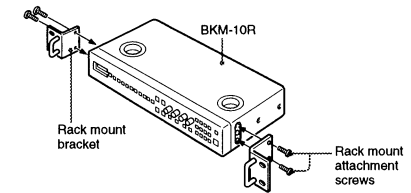
## Mounting the Unit in a Rack

To mount the BKM-10R in an EIA standard 19-inch rack, an optional MB-510 Rack Mount Kit is required.

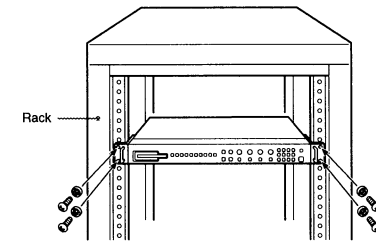
Proceed as follows to mount the unit in the rack.

**1** Remove the four feet from the bottom of the BKM-10R.

**2** Use the rack mount attachment screws supplied with the BKM-10R to attach the rack mount brackets of the optional MB-510 Rack Mount Kit to each side of this unit.



**3** Screw the rack mount brackets to the rack to mount the BKM-10R in the rack. Use screws that match the size of the rack's screw holes.



## Specifications

---

### General

Power requirements 5 V DC (supplied from the connected monitor)  
Power consumption 0.5 W  
0.7 W max.  
Maximum dimensions (w/h/d) 424 × 44 × 157 mm (16 3/4 × 1 3/4 × 6 1/4 inches)  
Mass 1.4 kg (3 lb 1 oz)  
Operating temperature 0°C to 40°C (32°F to 104°F)  
Recommended working temperature 20°C to 30°C (68°F to 86°F)  
Operating humidity 0% to 90% (no condensation)

---

### Control connectors

DISPLAY UNIT D-sub 9-pin, × 1

---

### Accessories supplied

Rack mount attachment screws (4)  
Operation Manual (1)

---

### Accessories not supplied

BKM-12Y Monitor Memory Card  
MB-510 Rack Mount Kit

---

### Related equipment

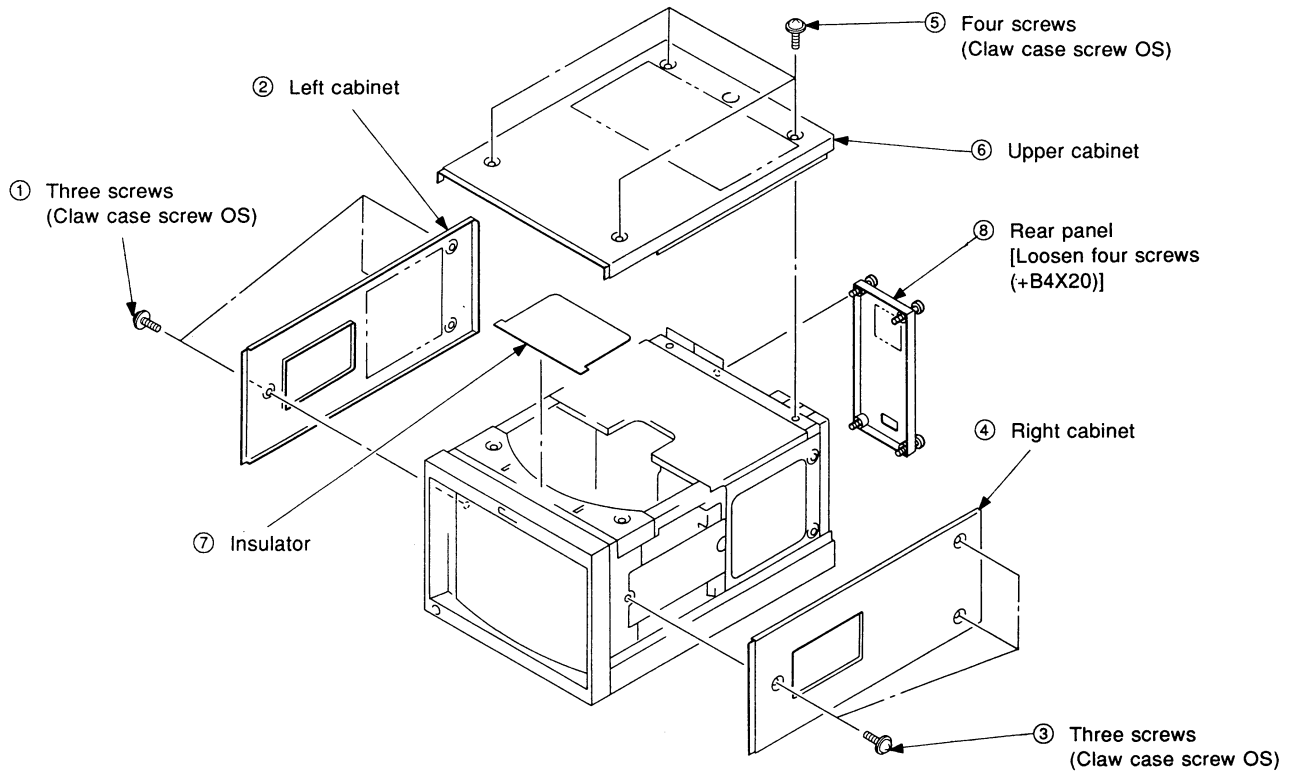
BVM-20F1U/20F1E/14F1U/14F1E Color Video Monitor

Design and specifications are subject to change without notice.

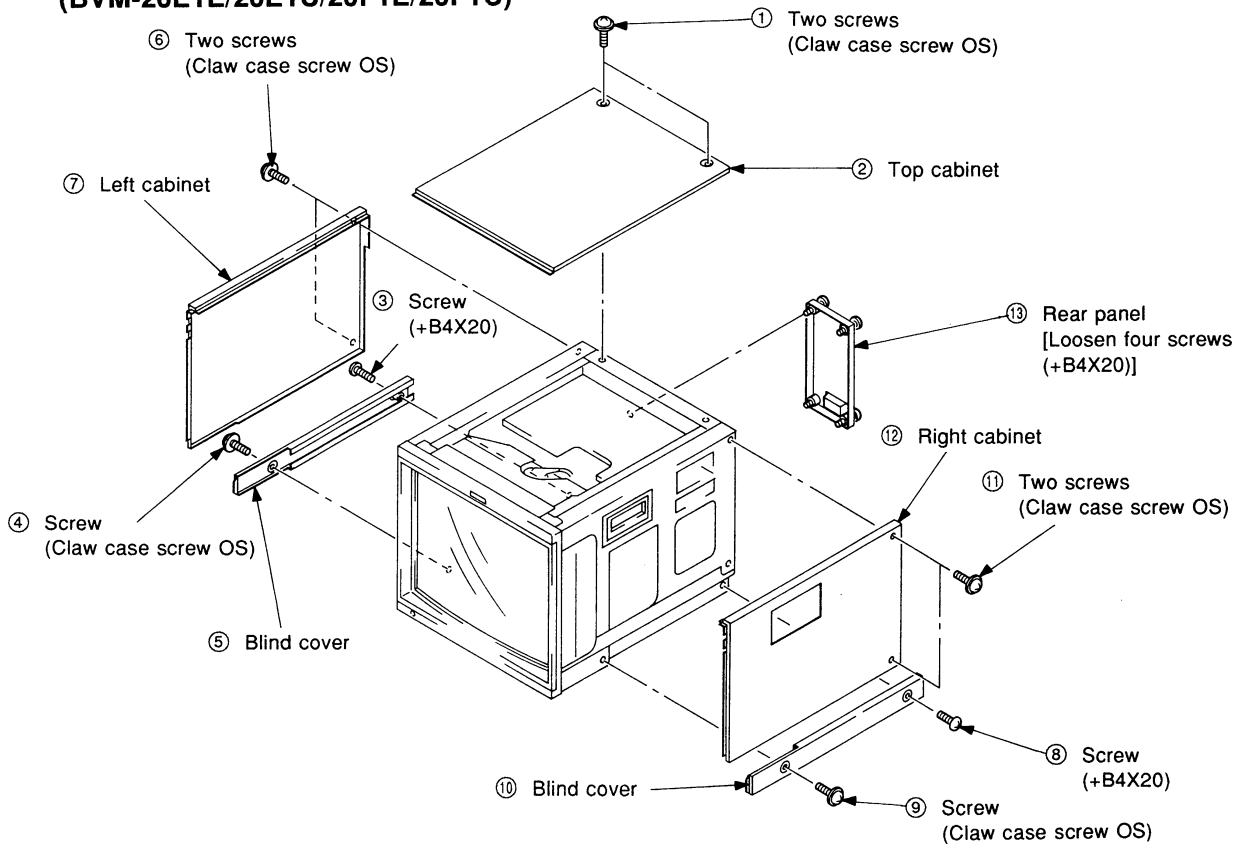


## SECTION 2 DISASSEMBLY

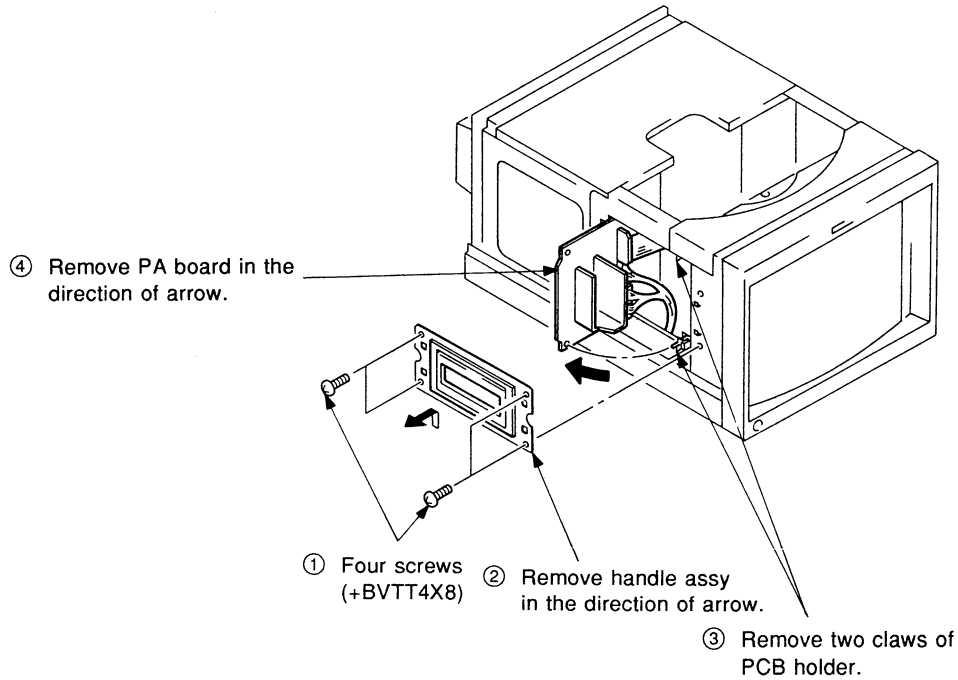
### 2-1-1. CABINET REMOVAL (BVM-14E1E/14E1U/14E5E/14E5U/14F1E/14F1U/14F5E/14F5U)



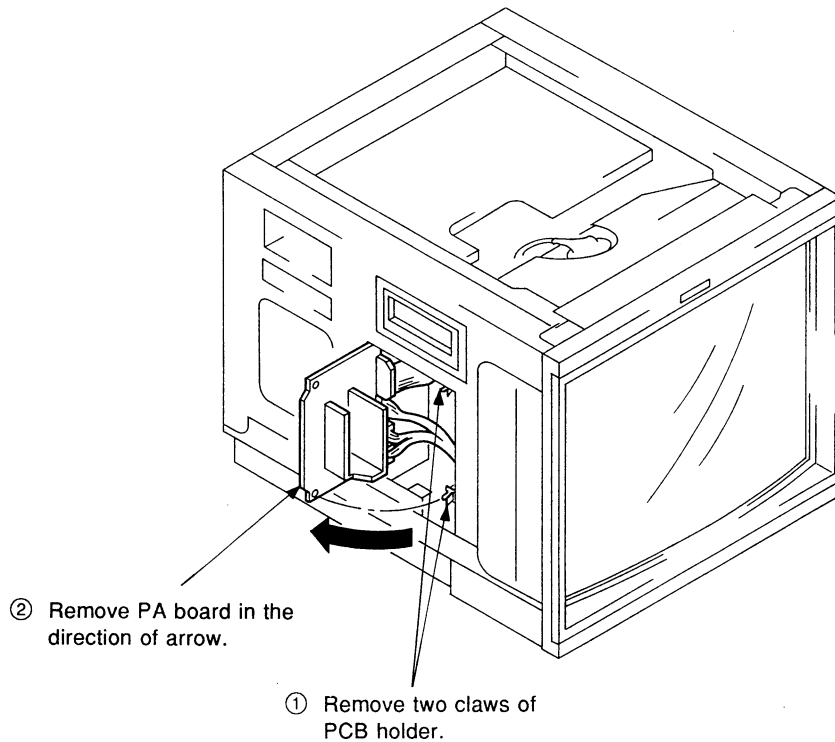
### 2-1-2. CABINET REMOVAL (BVM-20E1E/20E1U/20F1E/20F1U)



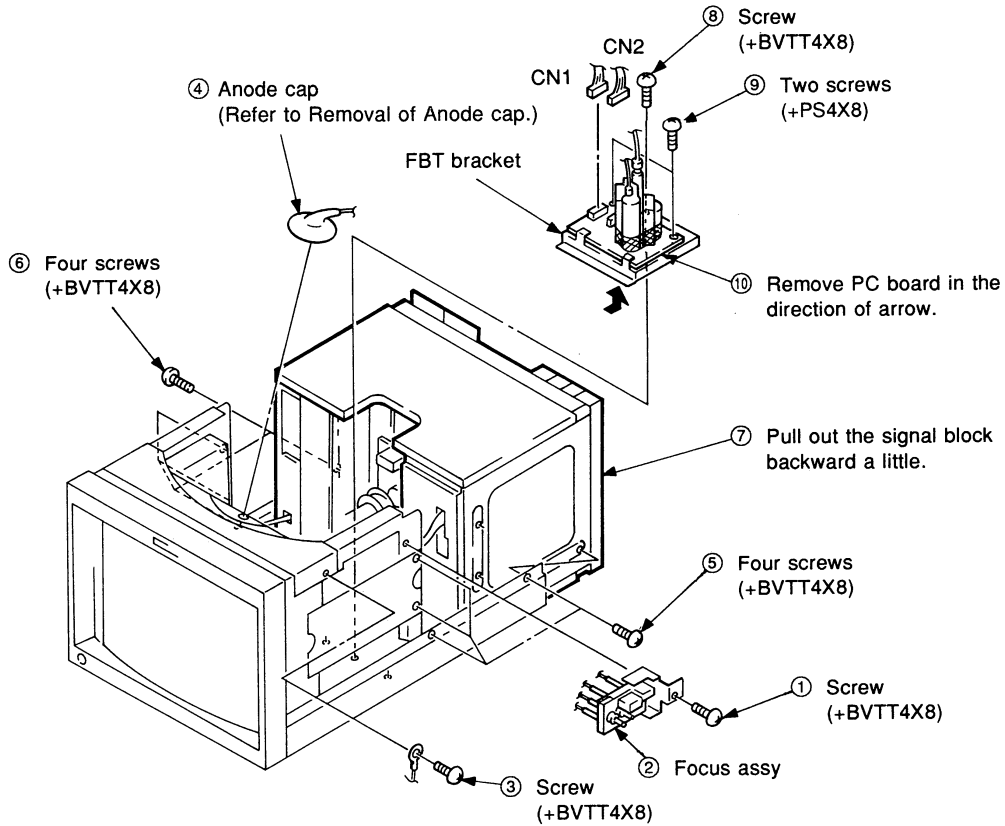
**2-2-1. PA BOARD REMOVAL  
(BVM-14E1E/14E1U/14E5E/14E5U/14F1E/14F1U/14F5E/14F5U)**



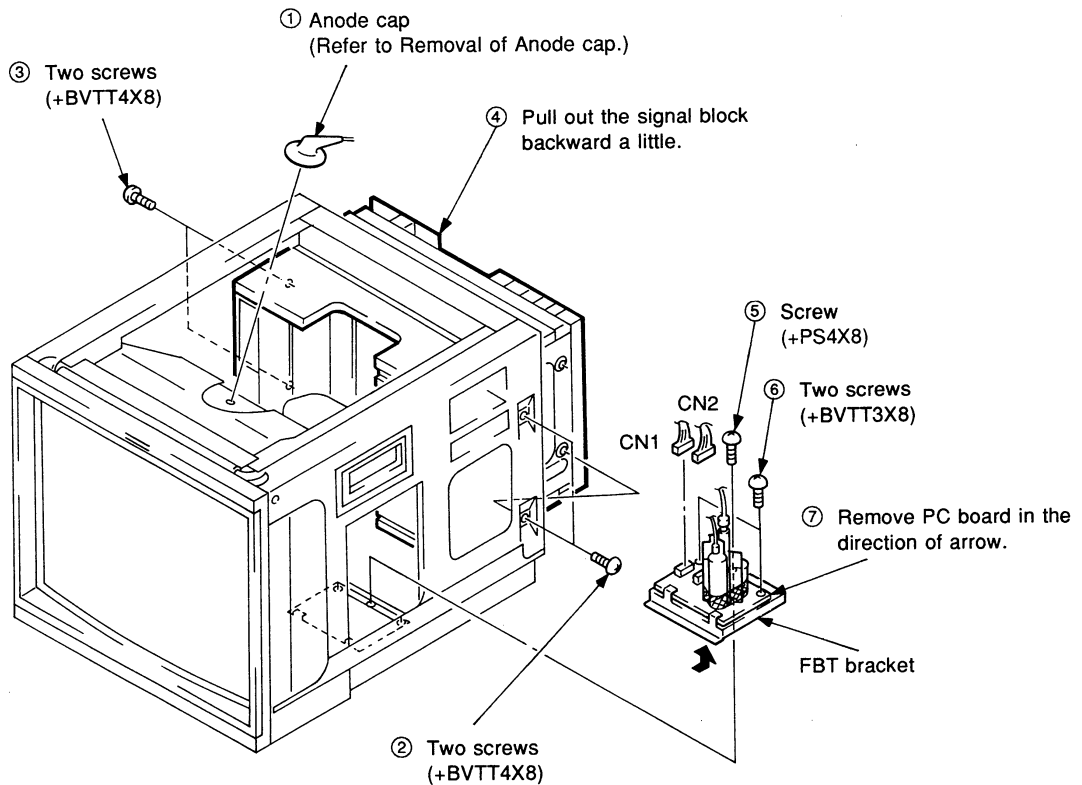
**2-2-2. PA BOARD REMOVAL  
(BVM-20E1E/20E1U/20F1E/20F1U)**



**2-3-1. PC BOARD REMOVAL  
(BVM-14E1E/14E1U/14E5E/14E5U/14F1E/14F1U/14F5E/14F5U)**

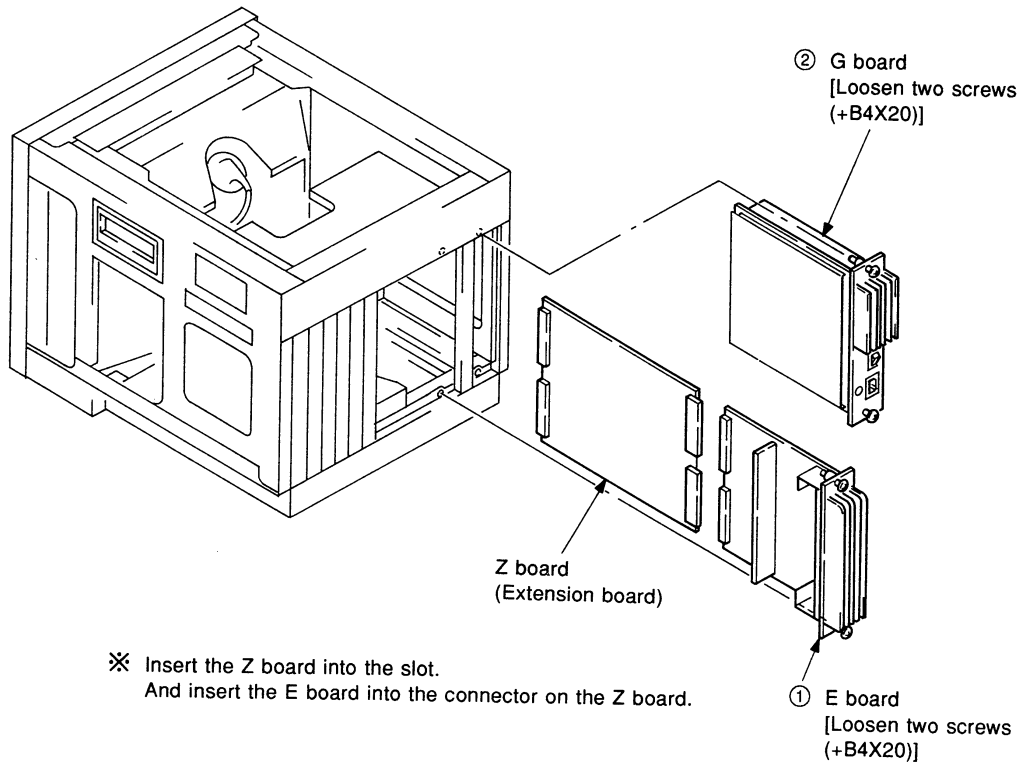


**2-3-2. PC BOARD REMOVAL  
(BVM-20E1E/20E1U/20F1E/20F1U)**



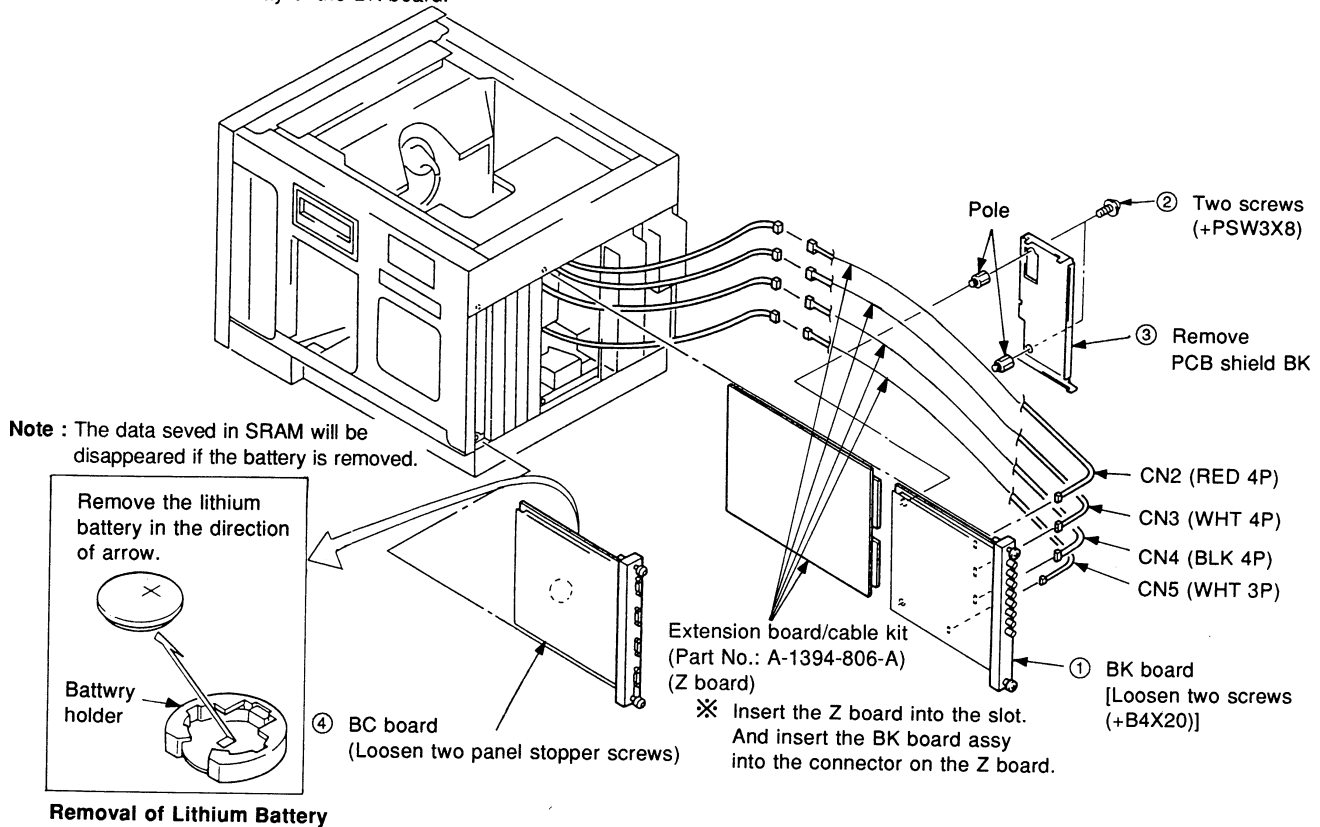
## 2-4. E AND G BOARDS REMOVAL AND CHECK

**Note:** The G board can be checked in the same way of the E board.

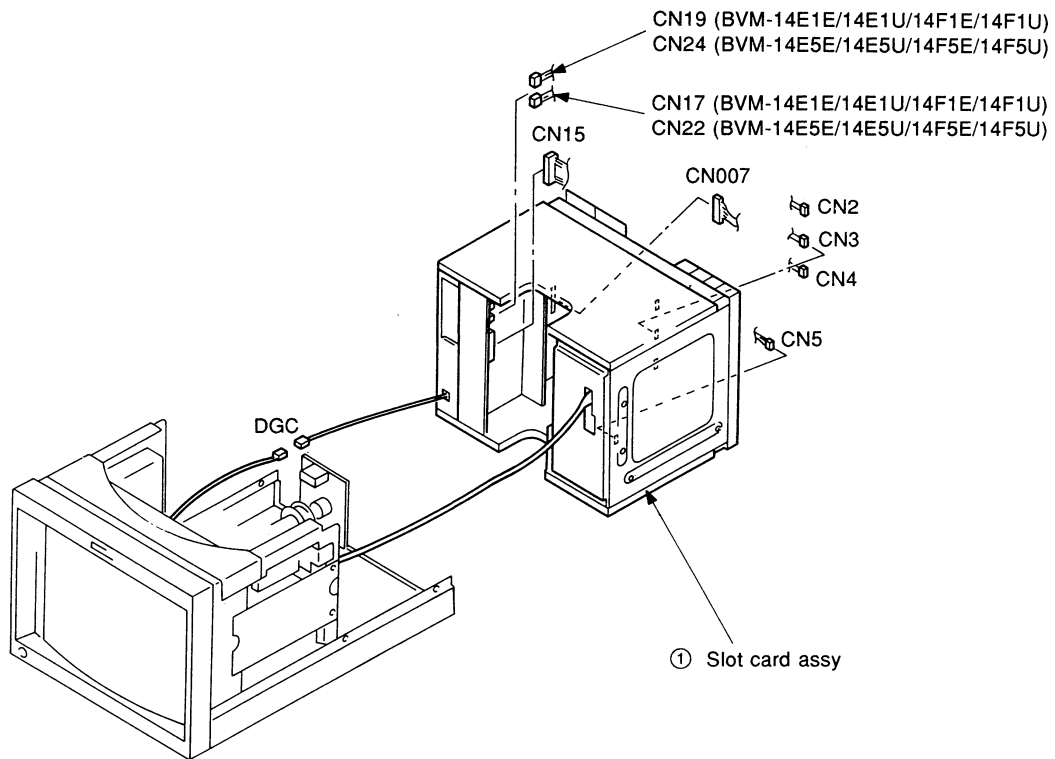


## 2-5. BC AND BK BOARDS REMOVAL AND CHECK

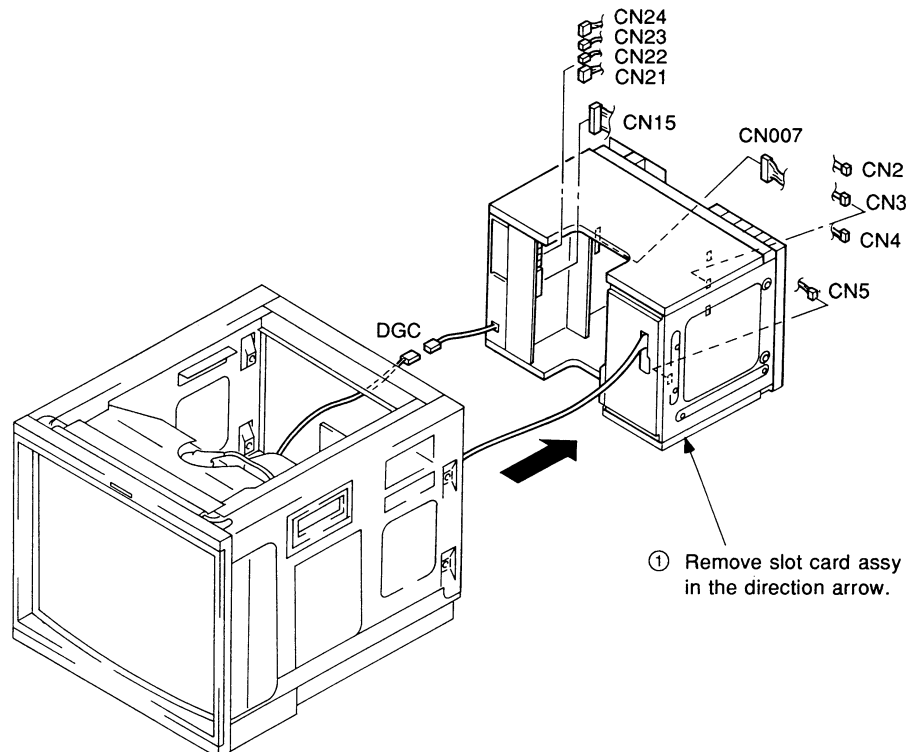
**Note:** The BC board can be checked in the same way of the BK board.



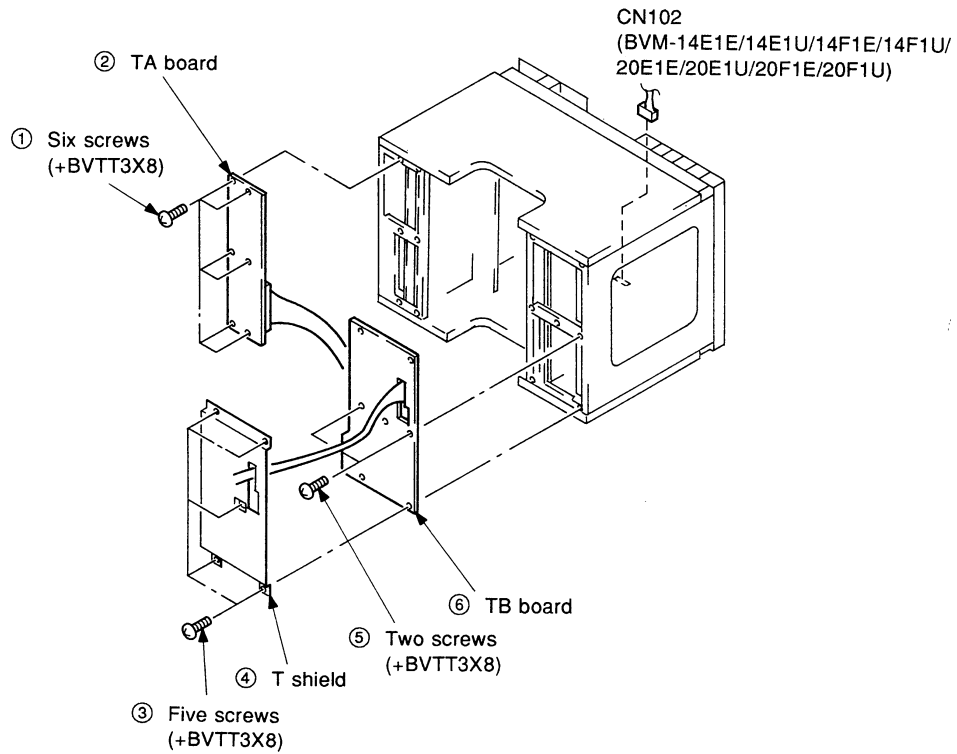
**2-6-1. SLOT CARD ASSY REMOVAL  
(BVM-14E1E/14E1U/14E5E/14E5U/14F1E/14F1U/14F5E/14F5U)**



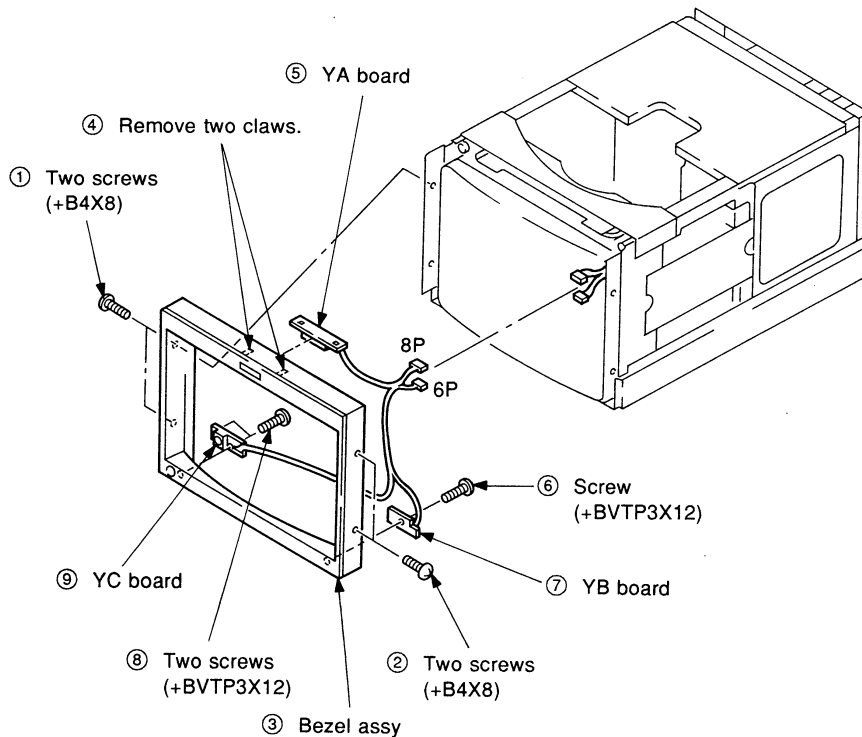
**2-6-2. SLOT CARD ASSY REMOVAL  
(BVM-20E1E/20E1U/20F1E/20F1U)**



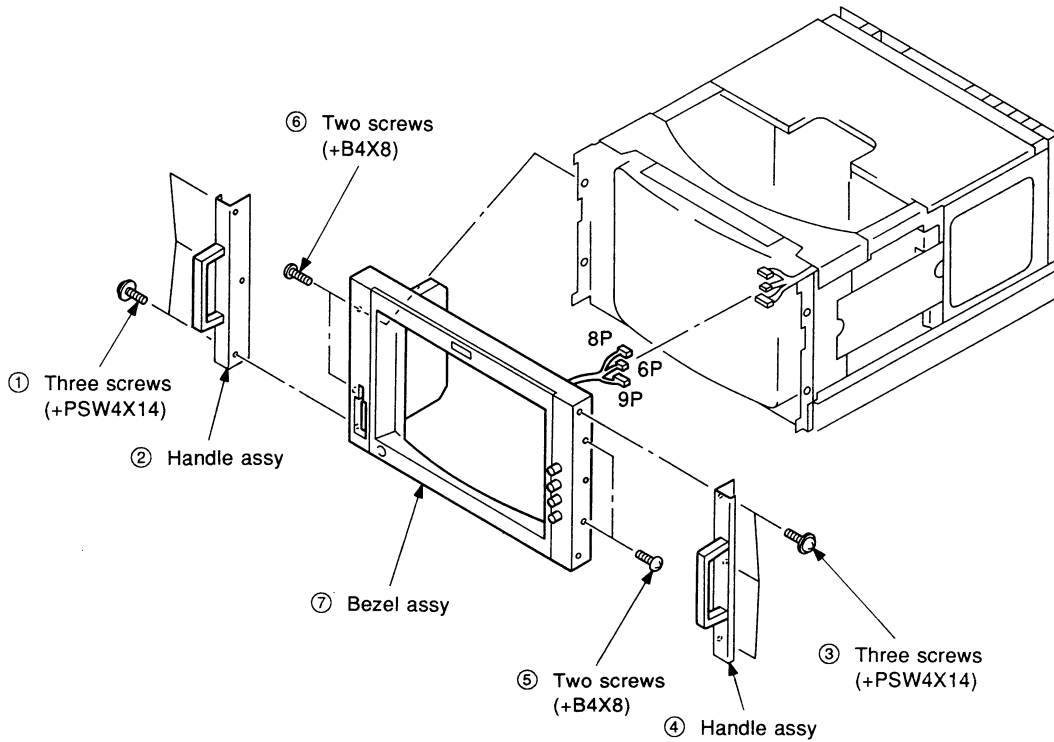
## 2-7. TA AND TB BOARDS REMOVAL



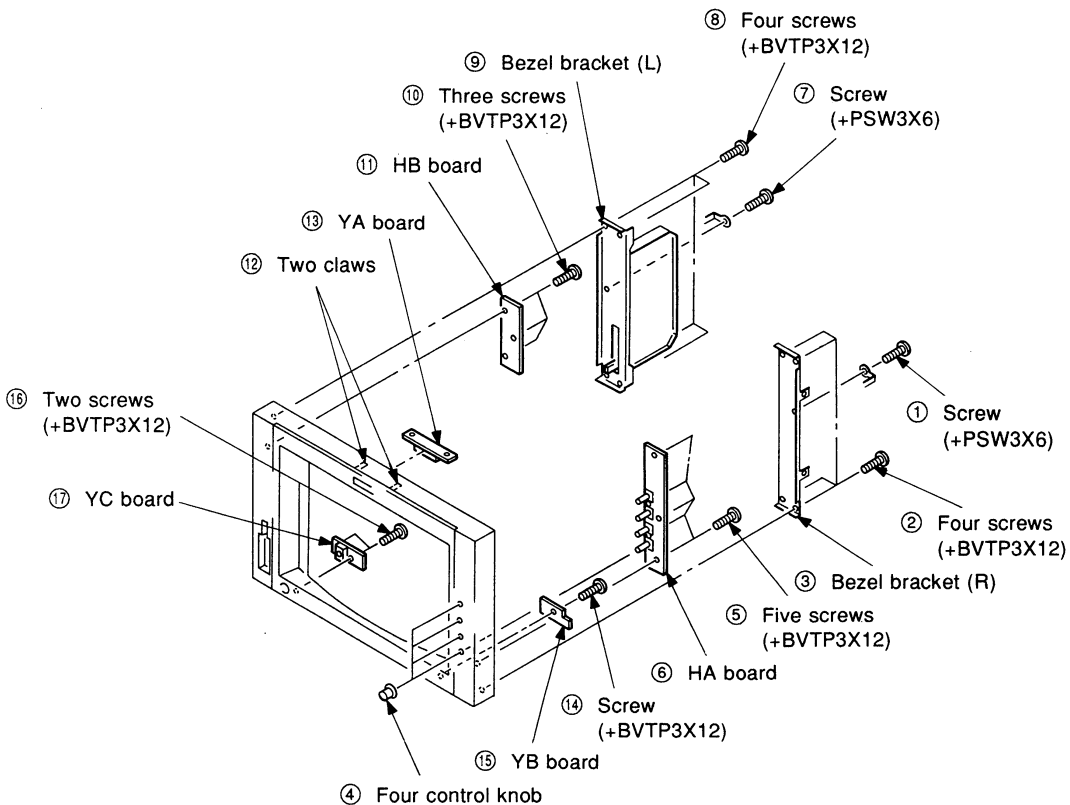
## 2-8-1-1. YA, YB AND YC BOARDS REMOVAL (BVM-14E1E/14E1U/14F1E/14F1U)



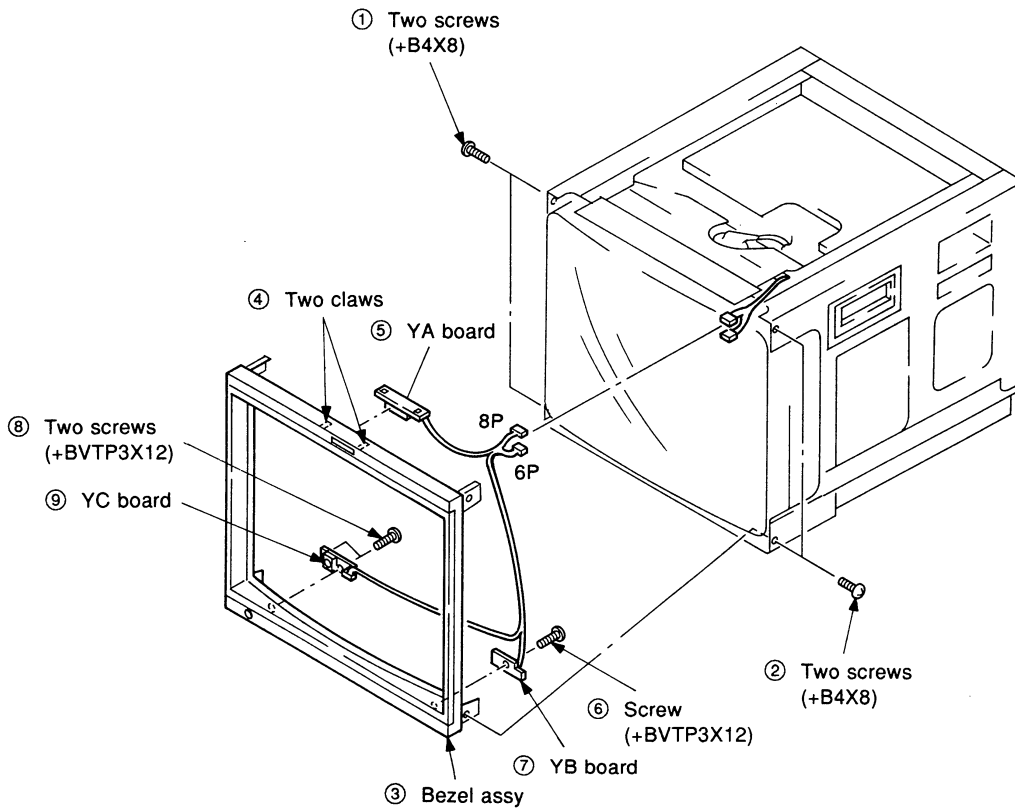
**2-8-1-2. BEZEL ASSY REMOVAL  
(BVM-14E5E/14E5U/14F5E/14F5U)**



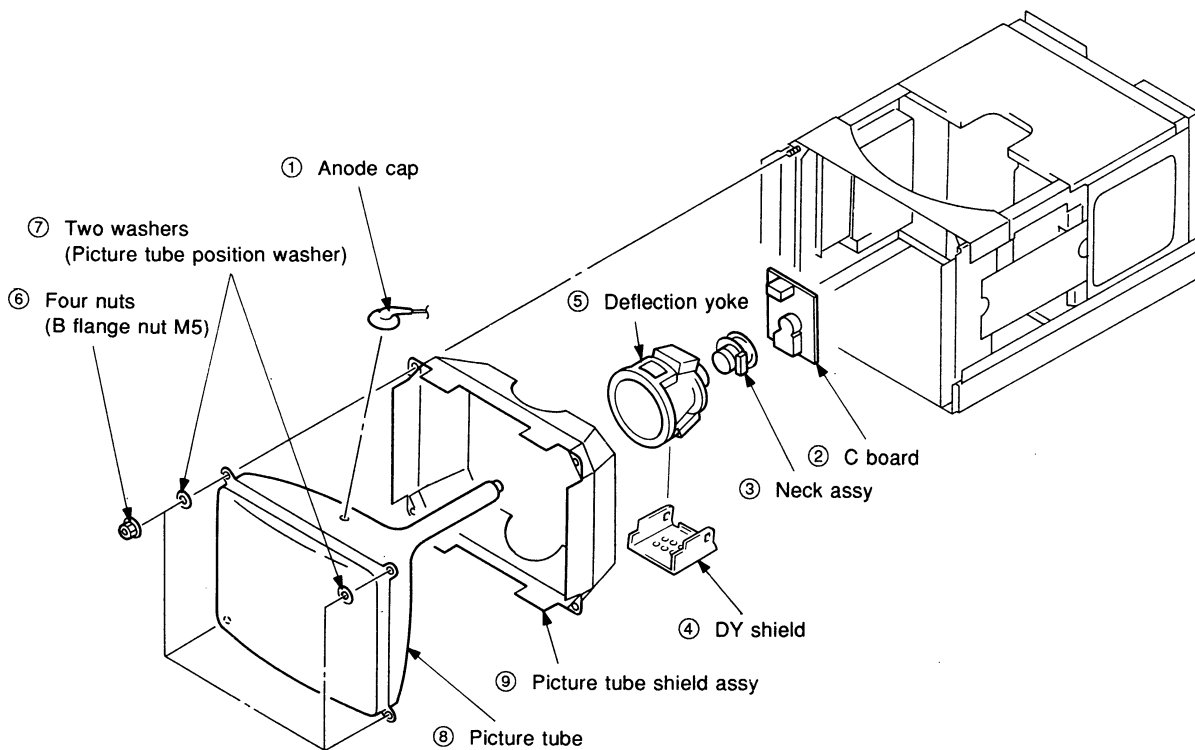
**2-8-1-3. HA, HB, YA, YB AND YC BOARDS REMOVAL  
(BVM-14E5E/14E5U/14F5E/14F5U)**



**2-8-2. YA, YB AND YC BOARDS REMOVAL  
(BVM-20E1E/20E1U/20F1E/20F1U)**

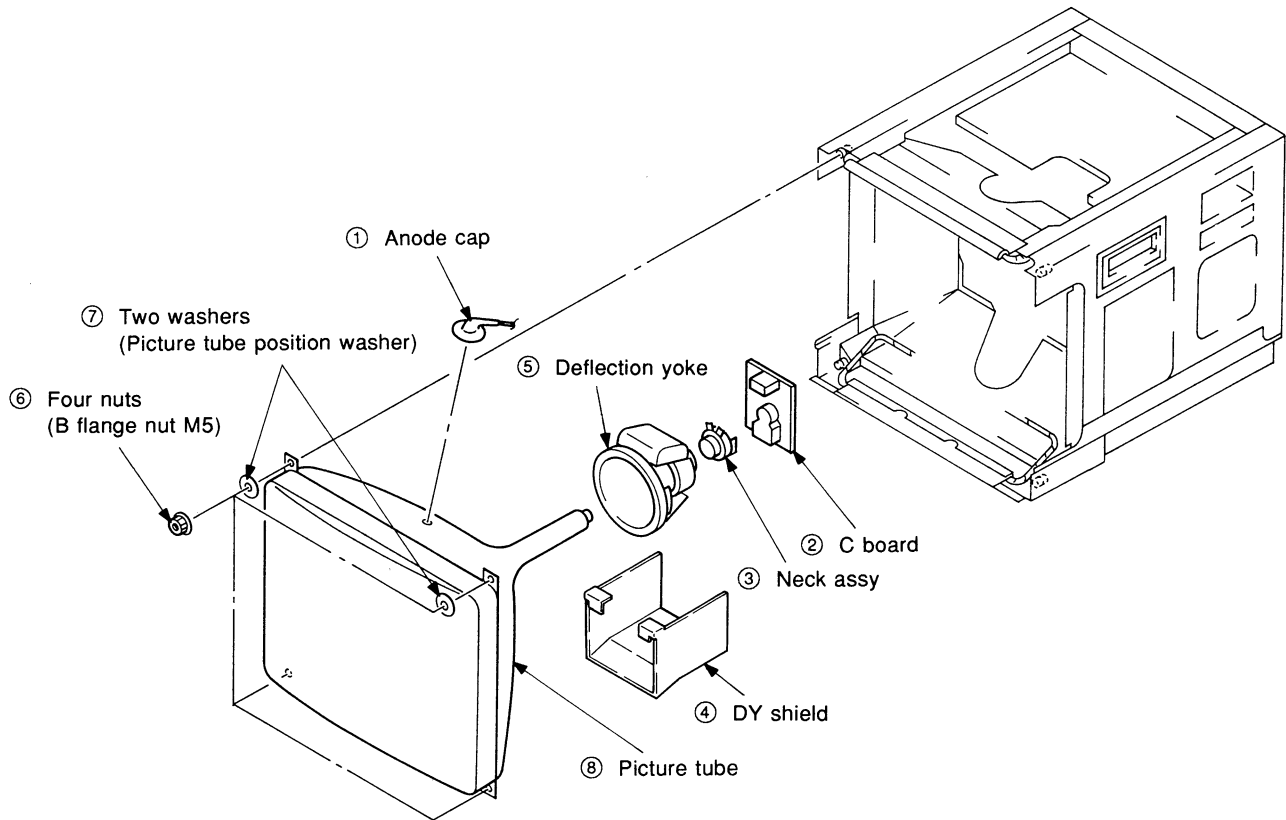


**2-9-1. PICTURE TUBE REMOVAL  
(BVM-14E1E/14E1U/14E5E/14E5U/14F1E/14F1U/14F5E/14F5U)**





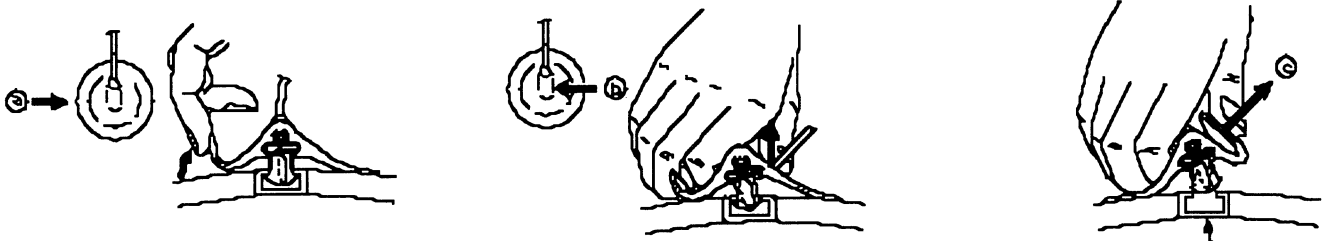
## 2-9-2. PICTURE TUBE REMOVAL (BVM-20E1E/20E1U/20F1E/20F1U)



### • REMOVAL OF ANODE-CAP

NOTE: Short circuit the anode of the picture tube and the anode cap to the metal chassis, picture tube shield or carbon painted on the picture tube, after removing the anode.

### • REMOVING PROCEDURES



1. Turn up one side of the rubber cap in the direction indicated by the arrow ㉑.

2. Using a thumb pull up the rubber cap firmly in the direction indicated by the arrow ㉒.

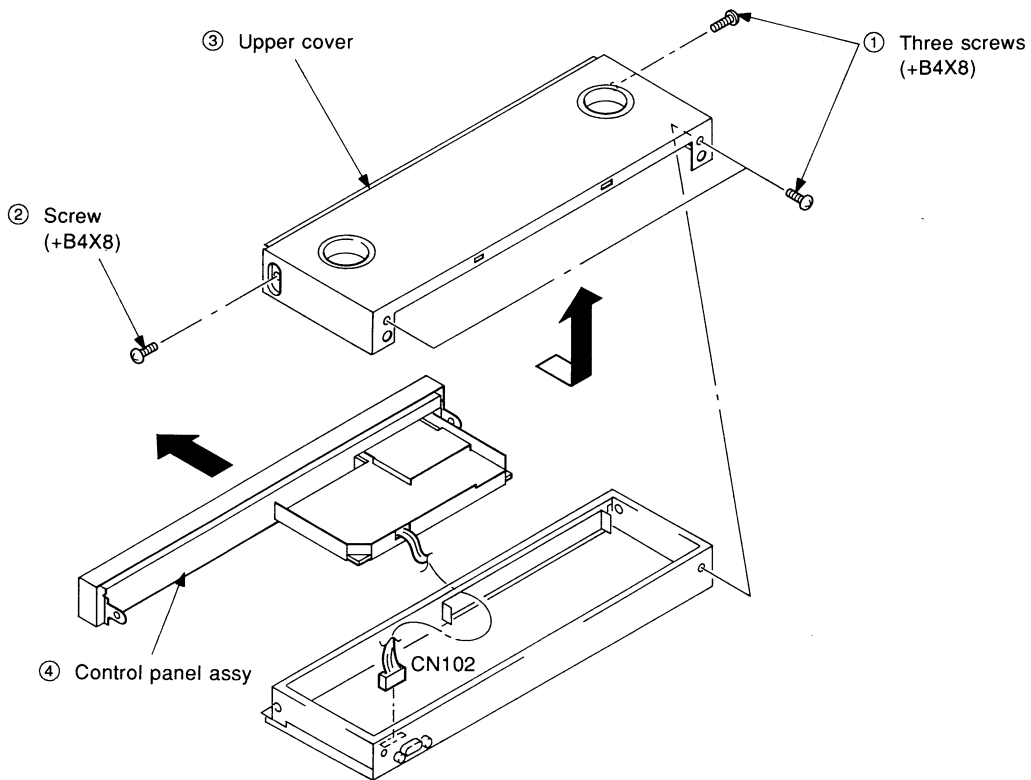
3. When one side of the rubber cap is separated from the anode button, the anode-cap can be removed by turning up the rubber cap and pulling up it in the direction of the arrow ㉓.

### • HOW TO HANDLE AN ANODE-CAP

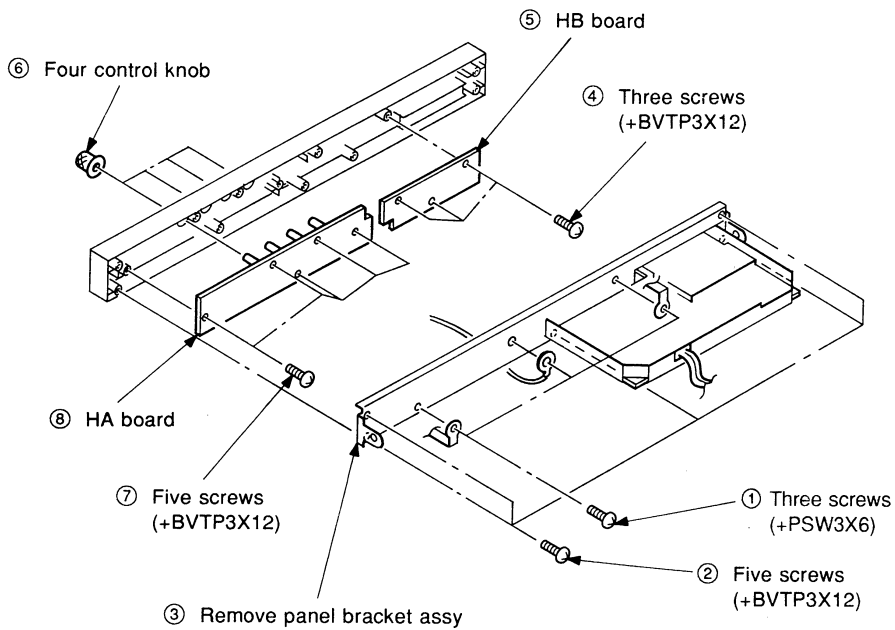
1. Don't hurt the surface of anode-caps with sharp shaped material!
2. Don't press the rubber hardly not to hurt inside of anode-caps!  
A material fitting called as shatter-hook terminal is built in the rubber.
3. Don't turn the foot of rubber over hardly!  
The shatter-hook terminal will stick out or hurt the rubber.



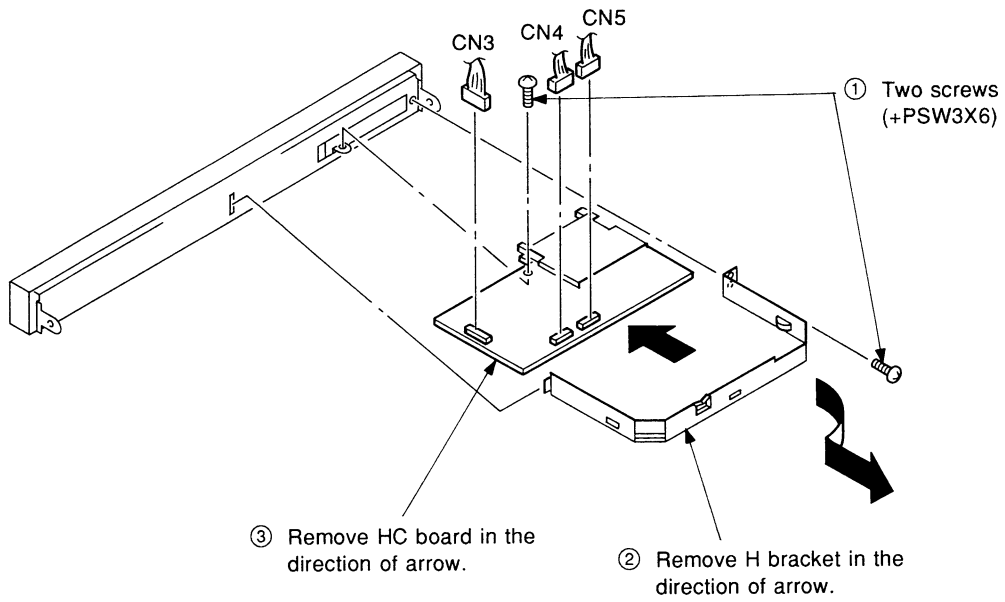
**2-10. UPPER COVER REMOVAL  
(BKM-10R)**



**2-11. HA AND HB BOARDS REMOVAL  
(BKM-10R)**



## 2-12. HC BOARD REMOVAL (BKM-10R)





## SECTION 3

### CIRCUIT DESCRIPTIONS

#### 3-1. BK Board Descriptions

##### 1-1. BK Select Switch

When the BK SELECT signal is LOW, the Y/G signal input to the Y/G terminal (TB1) is input to IC101 via the buffer amplifier (Q100 and Q102). When HIGH, the Y/G signal input to the (11B) terminal of CN2 is input to IC101.

At IC101, the 2Y/2G signal input to the (12B) terminal of CN2 is switched.

The same is performed for the PB/B signal and PR/R signal.

##### 1-2. Clamp Circuit (1)

The analog switch (IC101) turns on according to the Y-CLP-P pulse. As a result, the pedestal voltage of the Y/G signal is sample-held. At IC102 (1/2), this voltage and the reference voltage (0 Vdc) are compared, the bias current of the Y/G signal clamp amplifier (Q103 to Q105) is controlled so that the pedestal voltage of the Y/G signal becomes 0 Vdc. The same is performed for the PB/B signal and PR/R signal. However, the PR signal (R-Y signal) and PB signal (B-Y signal) are clamped by the C-CLP-P pulse.

##### 1-3. W B INSERT Pulse Insertion Circuit

To adjust the level of the R-Y signal and B-Y signal, the WHITE pulse and BLACK pulse are alternately inserted in the horizontal blanking period of the signals.

For the Y/G signal, at IC101 (3/3), the voltage in the period where the WHITE and BLACK pulses are inserted is made 0 Vdc. For the R-Y signal, the WHITE and BLACK pulses are inserted at IC301 (3/3). The level of the WHITE pulse is set by the R-Y PULSE LEVEL voltage. The level of the BLACK pulse is set by the R-Y CLAMP OFFSET voltage. These two voltages are switched by the WHITE INSERT P at IC500 (2/3), passed through IC300 (1/2), and input to IC301 (3/3). The same is performed for the B-Y signal.

##### 1-4. Chroma Level Adjustment Circuit

The R-Y signal is level-adjusted by IC303 (gain control amplifier). The R-Y signal output from IC303 is input to IC304 (1/3) and the voltage of the WHITE pulse is sample-held. At IC302 (2/2), this voltage and the CHROMA voltage are compared, and the gain of IC303 is controlled. As a result, the WHITE pulse voltage becomes equal to the CHROMA voltage. Consequently, by varying the CHROMA voltage, the chroma level can be adjusted. The R-Y signal output from IC303 is also input to IC325. Here, the voltage of the BLACK pulse is sample-held. At IC320 (2/2), this voltage and the GND level is compared to control the DC bias of IC303. As a result, the pedestal level of the R-Y signal is fixed at the GND level. The same is performed for the B-Y signal.

##### 1-5. Matrix Circuit

The R, G, and B signals are created by inputting the Y, R-Y, and B-Y signals to the matrix circuit.

###### • R signal matrix circuit

At Q140, the Y signal and R-Y signal are added to create the R signal.

###### • G signal matrix circuit

At Q306, the R-Y signal which had passed through IC305 (gain control amplifier) is added with the B-Y signal. This signal is inverted, amplified, and added to the Y signal at Q350 to create the G signal. The mixing rate is determined by R332, R333, and R338. The R-Y, and B-Y GAIN is finely adjusted.

###### • B signal matrix circuit

At Q540, the Y signal and B-Y signal are added to create the B signal.

##### 1-6. RGB switch

The RGB signal and R, G, and B signals are switched after the matrix circuit.

##### 1-7. Clamp Circuit (2)

The voltage of the BLACK pulse of the R signal is sample-held by IC107. At IC106 (1/2), this voltage and the GND level are compared and the DC bias of the R signal amplifier (Q142 to Q144) is controlled. As a result, the pedestal level of the R signal is fixed at the GND level.

The same is performed for the G and B signals.

##### 1-8. Half Blanking Switch

The character is half-blanked by the CHAR BLK signal.

##### 1-9. 100 IRE Pulse, SET UP Pulse Insertion Circuit

To adjust the contrast, the 100 IRE pulse and SET UP pulse are alternately inserted in the horizontal blanking period of the R, G, and B signals.

For the R signal, at IC110 (1/3), the 100 IRE pulse and SET UP pulse are inserted. The level of the 100IRE pulse is set by the R 100 IRE voltage. The level of the SET UP pulse is set by the R SET UP voltage. These two voltages are switched by WHITE INSERT P by IC113 (3/3), and input to IC110 (1/3). The same is performed for the G and B signals.

##### 1-10. Blue-Only Switch

In the blue-only mode, the B signal is output instead of the R signal at IC110 (3/3), and the B signal is output instead of the G signal at IC310 (3/3).

##### 1-11. Contrast, Bright Adjustment Circuit

The R signal is contrast-adjusted by IC112 (gain control amplifier). The R signal output from IC112 and amplified by Q167 to Q169, input to IC113 (1/3), and the voltage of the 100 IRE pulse is sample-held. At IC114 (1/2), this voltage and the CONT voltage are compared, and the IC112 gain is controlled. As a result, the 100 IRE pulse and CONT voltage becomes equal. Consequently, by varying the CONT voltage, the contrast level can be adjusted. The R signal output from Q167 to Q169 is also input to IC113 (2/3). Here, the voltage of the SET UP pulse is sample-held. At IC114 (2/2), this voltage and the GND level is compared to control the DC bias of IC112. As a result, the pedestal level of the R signal is fixed at the GND level.

The DC bias of the R signal amplifier (Q167 to Q169) is controlled by the BRT voltage to adjust BRIGHT.

At IC701 (1/3), the BRT voltage is created by switching the BRIGHT voltage and BRT CENTER voltage in the period inserted with the pulse (100IRE pulse, and SET UP pulse) and in other periods.

The same is performed for the B and G signals.

##### 1-12. Pulse Insertion Circuit

At IC116, The BIAS REF pulse, DRIVE REF pulse, and character pulse are inserted in the R signal. The level of the BIAS REF pulse is set by the BIAS REF voltage. The level of the DRIVE REF pulse is set by the DRIVE REF voltage.

The same is performed for the B and G signals.

##### 1-13. Drive Control Amplifier

To prevent the drive current of the CRT cathode from exceeding the reference value, and the drive voltage from exceeding the reference value, the levels of the R, G, and B signals are controlled.

The drive current of the CRT cathode is detected by the current of Pin ⑤ of the VIDEO OUT amplifier (IC119). The current of Pin ⑤ is clamped, I/V-converted by IC123 (2/2), sampled by IC126 (2/3), and compared with the reference voltage (R DRIVE IK) at IC127 (2/2). When the drive current exceeds the reference value, the signal output from IC127 (2/2) is passed through IC117 (3/3), Q170 to Q172, and input to IC115 (R drive control amplifier) to lower its gain.

The drive voltage of the CRT cathode is detected by the voltage of Pin ⑨ of the VIDEO OUT amplifier (IC119). The voltage of Pin ⑨ is clamped by IC121 (1/2), sampled by IC126 (1/3), and compared with the reference voltage (R DRIVE V) at IC127 (1/2). When the drive voltage exceeds the reference value, the signal output from IC127 (1/2) is passed through IC117 (3/3) and Q170 to Q172 and input to IC115 (R drive control amplifier) to lower its gain.

The SUB CPU (IC902) sets whether to control the drive amount based on the drive current (current mode) or control the drive amount according to the drive voltage (voltage mode) (IK/V SW). Normally, the SUB CPU operates in the voltage mode and sets into the current mode during WB adjustment. The DRIVE COMP is used for converting the data of DRIVE V in the voltage mode, and the data of DRIVE IK in the current mode.

##### 1-14. Clamp Circuit (3)

The voltage of the BLACK pulse of the R signal is sample-held by IC117 (2/3). At IC118 (1/2), this voltage and the GND level are compared and the DC bias of the R signal amplifier (Q174 to Q176) is controlled. As a result, the pedestal level of the R signal is fixed at the GND level.

The same is performed for the G and B signals.

##### 1-15. Cut-Off Switch

At IC117 (1/3), the VIDEO TIMING pulse is used to switch between the R signal and cut-off voltage (-0.3 Vdc).

The same is performed for the G and B signals.

##### 1-16. VIDEO OUT Amplifier

IC119 is used to drive the R signal cathode of the CRT.

The same is performed for the G and B signals.

##### 1-17. G2 Control

Of the G2 R signal, G2 G signal, and G2 B signal, the signal with the lowest voltage is input to IC705 (1/2), compared with the reference voltage (G2 REF) to become the G2 CONTROL signal, and output from Pin (10B) of CN1 to the PA board to control the G2 voltage of the CRT.

##### 2. ABL, Overload Detection

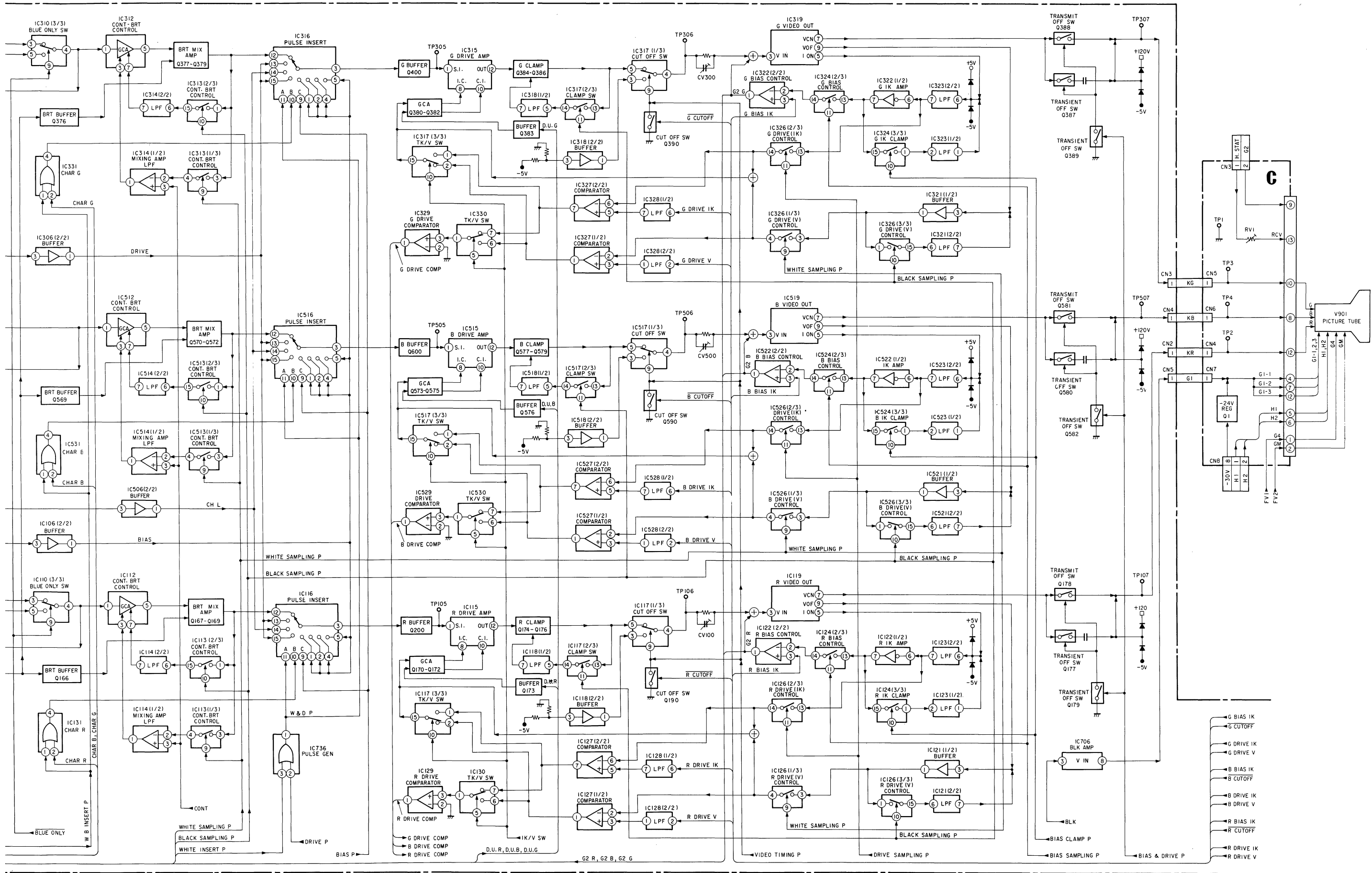
At IC901 (1/2), the ABL voltage and reference voltage (-1 Vdc) are compared. Normally, the ABL voltage is above -1 Vdc and therefore the output level of IC901 (1/2) is HIGH. If the ABL voltage goes down and it becomes less than -1 Vdc, the CONT. BRT will be therefore controlled so that this voltage will become -1 Vdc (constant). The output level of IC901 (1/2) is set to lower than the CONTRAST voltage and therefore the OVERLOAD signal and therefore the OVERLOAD signal output from IC904 (1/2) becomes HIGH.

##### 3. Control Circuit

The sub CPU (IC902) performs serial communication with system controller using the three signals MISO, MOSI, and SCLK, and outputs the control signal according to the instructions of the system controller.

This IC also reads the adjustment data of the EEPROM (IC905) and outputs the adjustment voltage from the D/A converter (IC906 to IC911).









## **3-2. BC Board Descriptions**

Carries out the switching of the switches on each board and setting of DAC data.

### **1. Serial Communication with Boards**

The system control CPU (IC1) carries out serial communication with the sub CPU of each board inserted in the slots using the 4 signals-MISO, MOSI, SLCK, and SLOT NO. It regularly receives abnormal detection signals from the power supply circuit and deflection circuit, and information (KILLER) for discriminating between color and black/white for signals input from each input adapter. It chooses who to communicate with using the signals SLOT-0 to SLOT-7.

### **2. Internal Signal Generation**

IC104 to IC110 generates internal signals (PLUGE, 5STEP, WHITE, GRAY, CROSS HATCH). The clock generated by IC121 (525 mode:14.3181 MHz, 625 mode:14.1875 MHz) is input to IC120 (sync generator) to generate the sync signal.

### **3. VITC Reading**

The Y/G signal is input to IC102, IC103, and IC126, and the VITC signal is read and input to the CPU and to display the IC7 (character generator).

The Y/G signal is input to IC124 to display the closed caption signal.

### **4. Character Generator**

IC7 (character generator) is controlled to display the menu, etc.

### **5. Parallel Remote Control**

The input signal of CN5 (parallel remote control terminal) is read by IC5 (I/O PORT EXPANDER).

### **6. ISR Terminal**

The CPU (IC1) carries out communication with the ISR devices via IC23 (serial control unit) and IC27 and IC28 (RS232C transceiver).

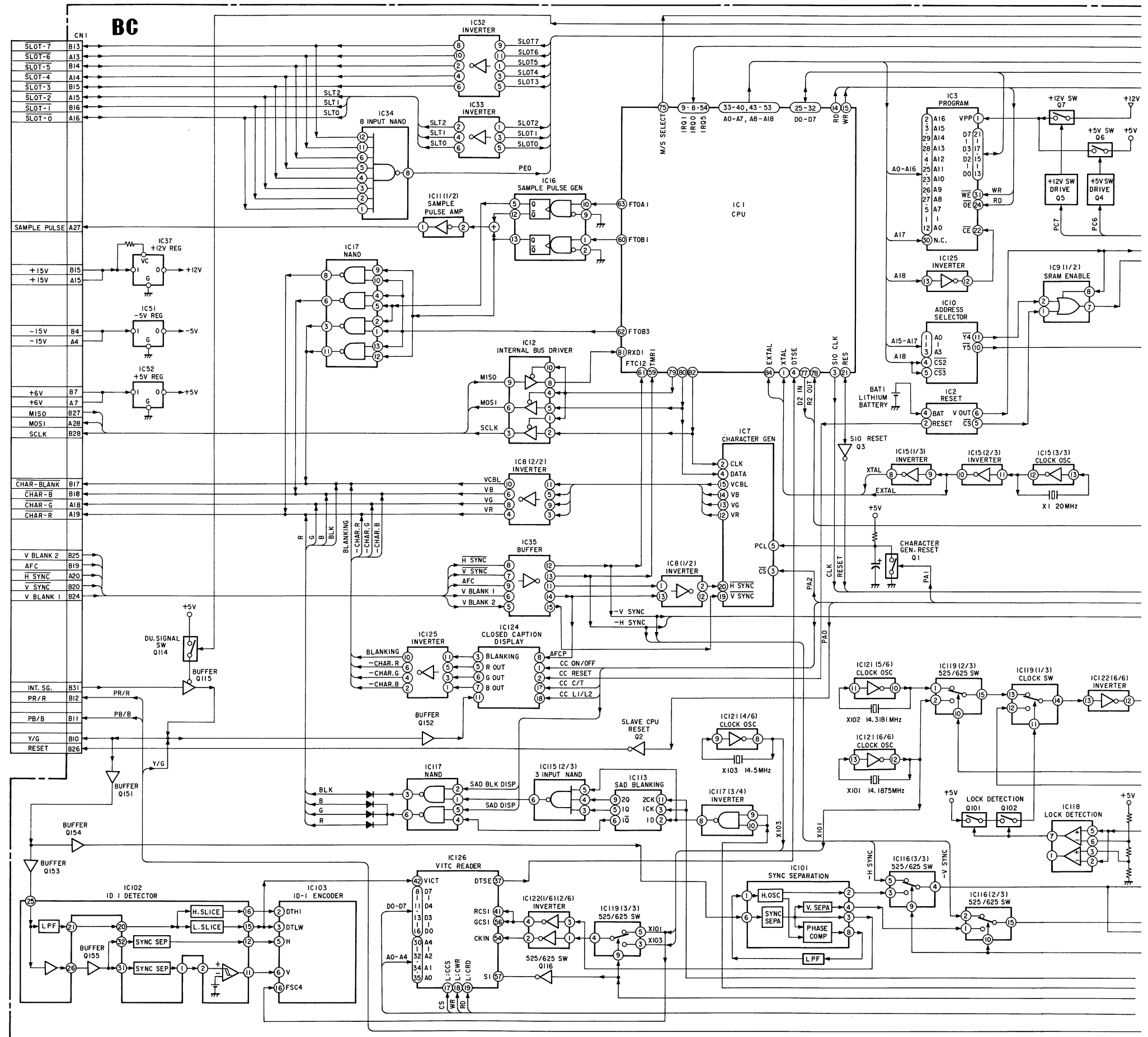
### **7. Serial Remote Terminal**

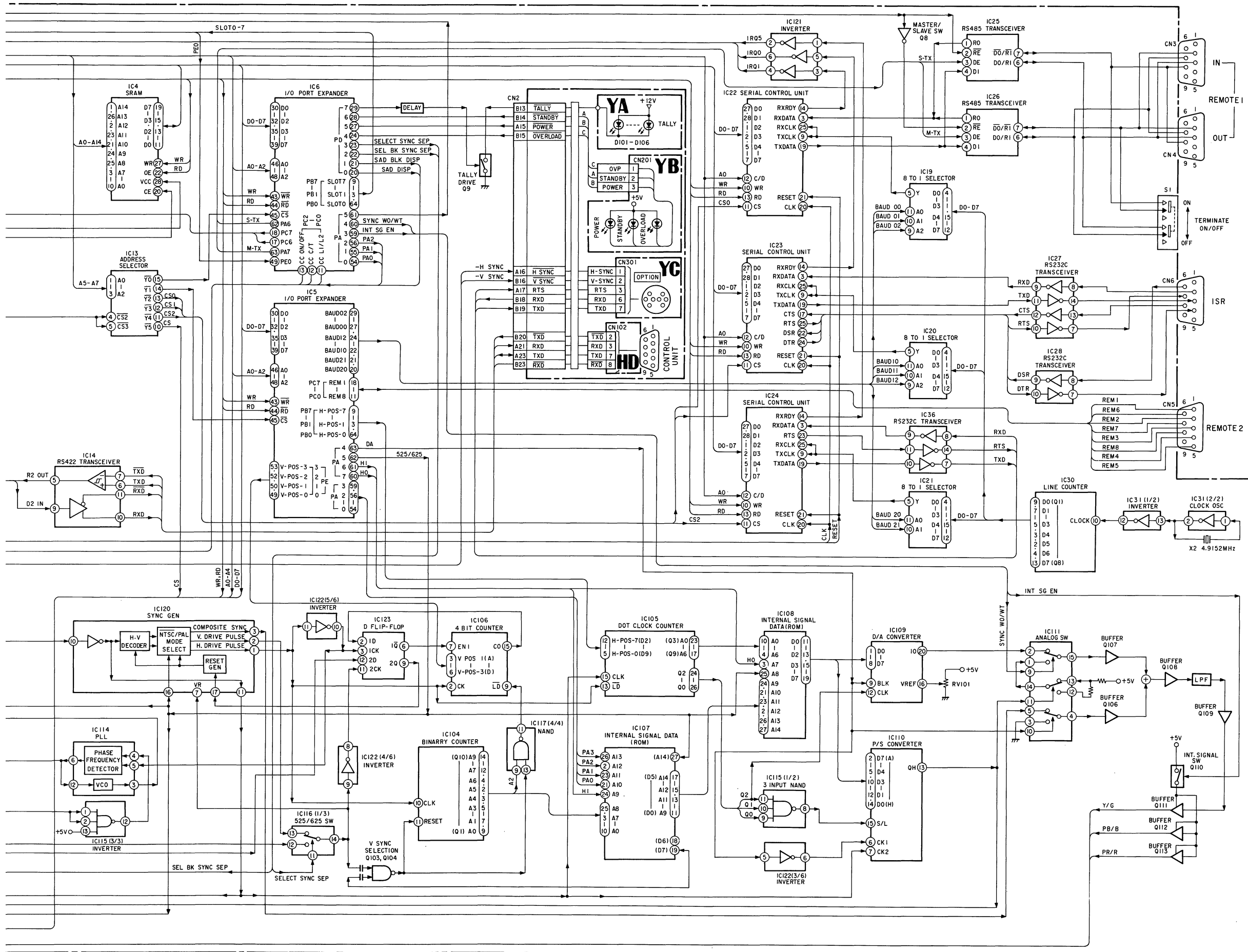
The CPU (IC1) carries out communication with the remote devices via IC22 (serial control unit) and IC25 and IC26 (RS485 transceiver).

### **8. Communication with Control Block (HC Board)**

The CPU (IC1) carries out communication with the control block (HC board) via IC14 (RS422 transceiver), receives key input information and the memory card reading data, and transmits LED light information and the memory card writing data.

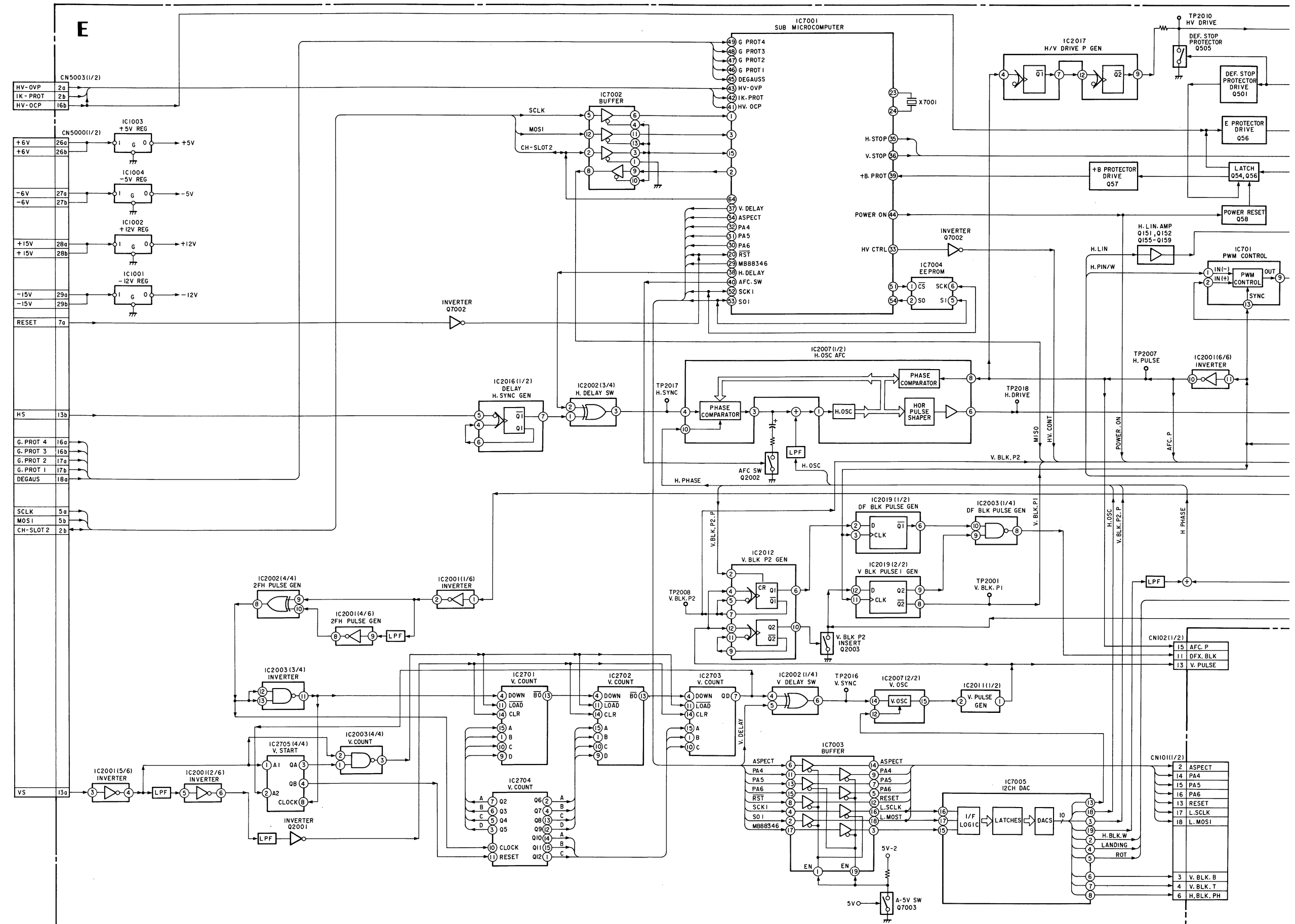
BC Board Block Diagram

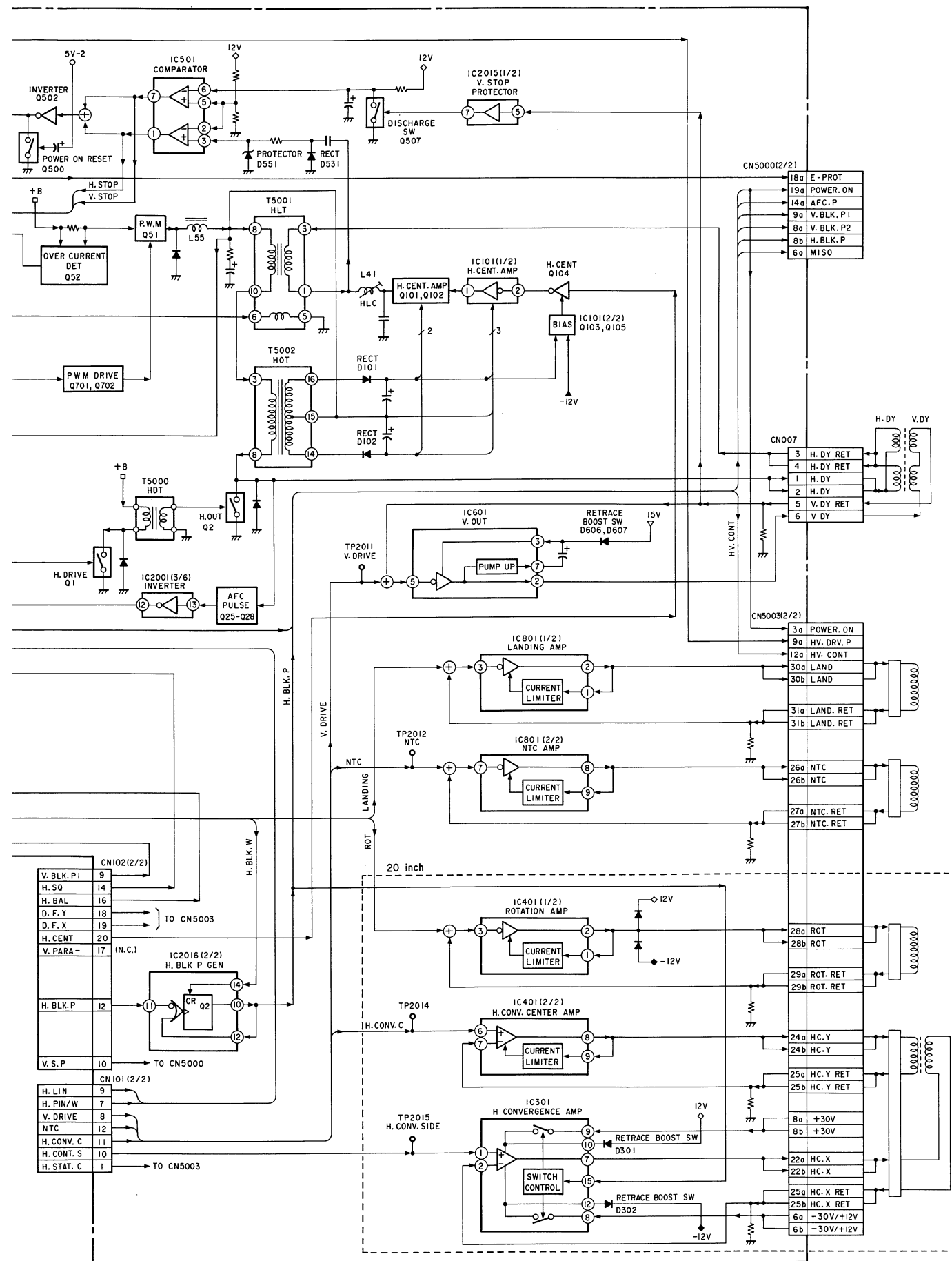




### 3-3. E Board Descriptions

#### E Board Block Diagram





## 1. Horizontal System

### 1-1. H DELAY Circuit

Negative pulses are generated at IC2016 with the H SYNC falling edge as the trigger. In the normal mode, these pulses are passed through IC2002 as they are and input to the AFC circuit. In the H DELAY mode, they are inverted by IC2002 and input to the AFC circuit.

In the AFC circuit, as the falling edge of the input pulse is taken as the reference signal for phase comparison, the reference signal only delays the width of the negative pulses in the H DELAY mode.

### 1-2. AFC Circuit

In IC2007 the H SYNC input to Pin ④ and the H.OSC signal inside the IC are phase-compared, output to Pin ③, and passed through the low pass filter to control the H.OSC of Pin ①. The freerunning frequency of H.OSC is set by the H.OSC output from the D/A converter (IC7005). The H.PHASE voltage is input to Pin ⑩ to set the oscillation phase of H.OSC. The H.BAL signal from IC115 of the D board is added to the H.PHASE voltage to correct the H.PIN.BAL, H KEY.BAL. The H.PULSE generated by T5002 (HOT:Horizontal output transformer) is waveform-shaped by Q25 to Q28 and input to Pin ⑧ of IC2007. Inside the IC, it is phase-compared with H.OSC to control the H.DRIVE pulse output from Pin ⑥.

### 1-3. Horizontal Deflection Circuit

The H.DRIVE pulse is passed through Q1, T500 (HDT), supplied to Q2 (H.OUT) to switch Q2 and drive T5002 (HOT) and H.DY.

The power supply of the horizontal output circuit is generated by IC701 (RWM control) by switching Q51 to improve the power efficiency. The H PIN/W voltage from IC114 of the D board is input to IC701 to control the power voltage.

### 1-4. H Center Circuit

Positive and negative power supplies from the secondary side output of T5002 (HOT:Horizontal output transformer) are generated as the power supply of the H center circuit. In the H center circuit (IC101, Q101 to Q105), the DC current flowing through the H.DY is controlled by the H.CENT signal from IC115 of the D board.

### 1-5. Landing Circuit

The LANDING voltage output from the D/A converter IC 7005 is input to IC801 to control the current flowing through the LANDING coil.

### 1-6. NTC Drive Circuit

The NTC signal output from IC108 of the D board is amplified to drive the NTC.

### 1-7. H Linearity Circuit

The H.LIN signal output from IC119 of the D board is amplified by Q151 to Q159, T5001 (HLT) is driven, and the H linearity compensation current is passed through the H.DY.

### 1-8. Rotation Circuit (20-Inch Model)

The ROTATION voltage output from IC7005 of the D/A converter is input to IC401 to control the current flowing through the ROTATION coil.

### 1-9. H Convergence Circuit (20-Inch Model)

The H.CONV.C signal output from IC111 of the D board is amplified by IC401 to drive the HC.Y. The H.CONT.S signal output from IC108 of the D board is amplified by IC301 to drive the HC.X.

## 2. Vertical System

### 2-1. V Counter

The H.SQ signal input to Pin ⑭ of CN104 is input to IC2002 to create the 2FH signal, which is used as the clock of the V counter. The V counter is reset by the V SYNC input to Pin ⑬ of CN5000. Consequently, the pulse output from the V counter synchronizes with the V SYNC. IC2002 inverts the pulse output from the V counter in the V DELAY mode to delay the falling edge of the waveform for the width of the pulse.

### 2-2. V.OSC Circuit

IC2007 synchronizes with the pulse from the V counter, oscillates, and generates the V period sawtooth waveform. This sawtooth waveform is compared with the reference voltage by IC2011 to create the V.PULSE. The freerunning frequency of V.OSC is set by the V.OSC voltage output from IC7005. The V.PULSE signal is input to the D board together with the AFC P signal to generate the V.DRIVE signal and various deflection correction signals.

### 2-3. Vertical Deflection Circuit

The V.DRIVE signal output from IC115 of the D board is amplified by IC601 to drive the V.DY.

### 3. Protection Circuit

#### 3-1. H.STOP, V.STOP Detection Circuit

The pulse generated for L41 and L101 by the H.DY drive current is detected by D531, the voltage obtained is input to Pin ③ of IC501, and compared with the reference voltage (6 Vdc) of Pin ②. When no more pulses are input, the voltage of Pin ③ of IC501 falls below the reference voltage so that the H.STOP signal output from Pin ① becomes LOW.

The pulse generated for R606 by the V.DY drive current is amplified by IC2015 (1/2) to switch Q507. Consequently, while pulses are input, C505 continuously discharges electricity. As a result, the voltage of Pin ⑥ of IC501 does not reach the reference voltage (6 Vdc) of Pin ⑤ and when no more pulses are input, the voltage of Pin ⑥ exceeds the reference voltage of Pin ⑤, and therefore the V.STOP signal output from Pin ⑦ becomes LOW.

When the H.STOP or V.STOP signal becomes LOW, Q502 turns OFF, Q505 turns ON, and the HV.DRV. pulse output is stopped. At the same time, as Q501 also turns ON, Q54 to Q56 turn ON, the E PROT signal becomes HIGH, and the power supply circuit sets into the standby state, Q57 also turns ON, and the +B PROT signal becomes LOW to indicate that a sub CPU error has occurred.

#### 3-2. Excessive Current Protection Circuit for Horizontal Deflection Circuit Power Supply

When the current of the horizontal deflection circuit power supply becomes abnormally great, Q52 turns ON. As a result, Q54 to Q57 turn ON, the E PROT signal becomes HIGH, and the +B PROT signal becomes LOW.

### 4. Control Circuit

The sub CPU (IC7001) performs serial communication with the system control CPU of the BC board using the three signals MISO, MOSI, and SCLK, and outputs the control signals POWER ON, DEGAUSE, AFC SW, H.DELAY, V.DELAY, etc. according to the instructions of the system control CPU (BC board IC1). It also reads the adjustment data of the EEPROM (IC7004) and output the adjustment voltage from the D/A converter (IC7005). In addition, it also controls the waveform output from IC112, IC115, and IC118 of the D board. The following protect detection signals are transmitted to the system control CPU from the sub CPU.

H. STOP, V. STOP, +B. PROT, HV\_OVP  
IK\_PROT, HV\_OVP, G.PROT1-4

### 3-4. D Board Descriptions

#### 1-1. Signal Generator (IC105)

The deflection correction waveform is generated. Based on the V.PULSE obtained by waveform-shaping the V.SAW waveform output from IC2007 of the E board at IC2011, the V period deflection correction signals (V4TH, VSIN, VPARA, and VSAW) are generated. Based on the AFC.PULSE waveform-shaped by IC2001 (Q25 to Q28) of the E board, the H period deflection correction signals (HSAW, HPARA, and HSQ) are generated.

#### 1-2. DEFLECTION Generator

Based on the VSIN, V.PARA+, and VSAW+ signals output from the signal generator (IC105), the following signals are generated. The signal level and waveform can be varied using the serial data from the system control circuit.

H. STAT. C, V. DRIVE, V. CONV T & B,  
H. BAL, H. CENT, V. CONV. C, H. LIN. GAIN,

#### 1-3. H. CONVER Generator

Based on the VSIN, V.PARA+, V.PARA-, and VSAW+ signals output from the signal generator (IC105), the following H convergence correction signals are generated. The signal level and waveform can be varied using the serial data from the system control circuit.

H. CONV. C, STAT, V. STAT, H. C. L, H. C. R

#### 1-4. D/A Converter

Based on the V4TH, V.PARA+, and VSAW+ signals output from the signal generator (IC105), the D/A conversion reference voltage is modulated and the following signals are generated. The signal level can be varied using the serial data from the system control circuit.

The adjustment voltage is also output.

- Modulated by V4TH signal  
CORNER PIN
- Modulated by VPARA+ signal  
H. MID. PIN, H. CENTER. PIN,  
DFY, T&B, DFY. SIDE
- Modulated by VSAW+ signal.  
DFY. PHASE
- Adjustment voltage  
DFX. CENTER, DFX. PHASE

#### 1-5. NTC Signal Generation

The V.CONV.T&B signal output from IC115 (DEFLECTION GEN) and the V.STAT signal generated by IC112 (H.CONVER GEN) are added and inverted by IC108 to create the NTC signal. The adjusting points are the following three.

V.STAT  
V.CONV. TOP  
V.CONV. BOT

#### 1-6. H.CONV. SIDE Signal Generation

IC108 modulates the H.C.L signal or H.C.R signal generated by IC112 (H.CONVER GEN) using the H.PARA+ signal output by IC105 (signal generator) to create the H.CONV.S signal. As for the HSQ signal, the H.C.L signal is selected at the left side of the screen, while the H.C.R signal is selected at the right side of the screen.

There are 5 adjusting points on the left and right sides each.

#### 1-7. H.LIN Signal Generation

IC203, IC108, and IC119 modulate and add the H.PARA— signal and H.SAW signal output by IC105 (signal generator) using the H.LIN GAIN signal and H.LIN BAL signal output by IC115 (DEFLECTION GEN), and H.MID.PIN signal and H.CENT.PIN signal output by IC118 (D/A converter) to create the H.LIN signal.

#### 1-8. D.F.X. Signal, D.F.Y. Signal Generation

IC301 modulates and adds the H.SAW+ signal and H.PARA— signal output by IC105 (signal generator) using the DFX.PHASE signal, DFX SIDE signal, DFX CENTER voltage output by IC118 (D/A converter) and V.PARA— signal output by IC105 to create the D.F.X signal.

IC111 (2/2) adds the DFY.PHASE signal and DFY.T&B signal output by IC118 (D/A converter) with the V.PARA+ signal output by IC105 (signal generator) to create the D.F. YX signal.



### 3-5. PA Board Descriptions

#### 1. High Voltage Regulator Circuit

The high voltage regulator of this unit uses a DC converter type power supply circuit to reduce the power consumption. The following is an outline of the operations of the high voltage regulator.

The detection voltage which is obtained by resistance-dividing the HV voltage with the high voltage detection resistance HVR inside the FBT is passed through the IC801 (2/2) buffer and input to IC501. IC501 compares the reference voltage inside IC501 and this detection voltage (difference amplification) and performs PWM modulation. Q102 is PWM-modulated and driven by the output of IC501. The voltage supplied to the FBT drive circuit (Q109, C108, C104, and FBT) is controlled by the ON/OFF of Q102. The HV voltage can be adjusted by changing the level of the detection voltage.

Next, when the HV voltage drops, the HV detection voltage also drops. As a result, the PWM output of IC501 works to expand the ON period of the Q102 switching FET.

The voltage switched by Q102 is passed through the combination choke (LOT) and supplied to the converter circuit for driving FBT. As the PWM modulator is synchronized by the HV DRV pulse, the size of the drain current of the FET output from Q109 of the FBT drive circuit depends on the ON period of Q102. Consequently, when the ON period of Q102 increases, the Q109 collector current increases and the C104 potential increases.

When Q109 turns OFF, a flyback pulse is generated by the combined inductance of the LOT and FBT and the resonance of C108 and transmitted to the secondary side of the FBT to generate the HV voltage.

#### 1-2. High Voltage Protector Circuit

HV is detected using the voltage of the HV.PROT winding, the tertiary winding of FBT.

The HV.PROT is connected to the  $\ominus$  input terminal of IC502 (2/2) via the rectification circuit composed of D802, R808, and C801.

When HV increases due to some error, fault, etc., the HV.PROT voltage also increases. When the voltage of the  $\ominus$  input terminal increases above the  $\oplus$  input terminal voltage, the operation reference voltage, the comparator output becomes LOW, and turns OFF IC501 via D502.

Consequently, the drive pulse of the high voltage converter is shut down and the high voltage output circuit is stopped.

#### 1-3. High Voltage Current Protector, ABL Circuit

The high voltage current protector holds down the high voltage regulator when the current  $I_k$  flowing through the CRT exceeds the setting value in errors and malfunctions.

The voltage obtained by resistance-dividing at R514 and R515 the difference between  $V_z$  (D901 Zener voltage) and the  $V_{ABL1}$  obtained by voltage-converting the current flowing through the FBT secondary winding at R6 is supplied to the  $\oplus$  terminal of the comparator, and the operating point voltage  $V_{ref}$  is supplied to the  $\ominus$  pin of the comparator.

The  $\oplus$  terminal voltage of the comparator is normally higher than the  $\ominus$  terminal voltage. When the CRT beam current increases, the  $V_{ABL1}$  voltage decreases and consequently the  $\oplus$  terminal voltage of the comparator also decreases. Therefore when the beam current, which makes the  $\oplus$  terminal voltage drop below the  $\ominus$  terminal voltage, flows through the CRT, the protector operates and shuts down the PWM control IC DRIVE, and holds down the high voltage regulator.

The ABL circuit serves to protect the CRT by preventing the beam current from exceeding the reference value.

The beam current flowing through the CRT flows to R3.  $V_{ABL2}$  is obtained by converting this current to voltage.  $V_{ABL2}$  is supplied to the  $\oplus$  terminal of IC901, and when it drops below the reference voltage of the  $\ominus$  terminal, ABL operates and makes the luminance consistent. Consequently, even if BRIGHT and CONTRAST are rotated, DRIVE is increased or the terminating resistor is removed so that the CRT beam current does not change.

#### 1-4. Screen (G2) Voltage Regulator

The drain pulse voltage of Q109 is rectified by the diode D201.

The regulator is composed of Q201, Q202, and IC401 (2/2).

The G2 voltage is supplied to be optimum the CRT cathode with the G2 CTRL voltage from the BK board.

#### 1-5. DF Drive Circuit

The DFX and DFY signal from the D board is amplified by Q301 to Q305 and T301 (DFX), and DFY is amplified by Q321 and Q322 to modulate the G4 and GM voltage of the CRT.





### 3-6. Power Supply Circuit Descriptions (G Board, GA Board, GB Board, and GC Board)

#### 1. RCC Switching Regulator (IC4 and T5)

The blocking oscillator is composed of IC4 and T5 (SRT). Immediately after the Main Power switch at the rear is turned on, first the regulator starts up because IC4 operates and generates the 5V voltage for DIGITAL, +12V voltage, and -12V voltage at the secondary side of T5. At the same time, the 18V voltage (For PFC CTRL IC) and 15V voltage (For half bridge switching regulator) are generated at the primary side of T5.

#### 2. PFC Switching Regulator

The power factor improvement circuit is composed of IC1, Q5, D10, T3, C28 of the G board, the GC board, and related parts. The power factor improvement circuit (referred to as PFC hereafter) of this power supply adopts the boost PWM control method. As it basically operates as the boost switching regulator in continuous current operation, the output voltage  $V_{pfc}$  is always higher than the peak value of the input power supply voltage. As the input voltage is a sine wave, in addition to voltage control, it controls current in proportion to the input voltage.

IC1 not only keeps the  $V_{pfc}$  voltage constant but also PWM-controls Q5 so that the current flowing to T3, that is the main power supply current is similar to the input voltage waveform. As a result, the power factor is improved because the input current and input voltage waveforms are similar. The GC board is composed of IC1, Q1, and the output voltage detection resistor. It creates a control signal which varies  $V_{pfc}$  in proportion to the input power supply voltage, and supplies them to IC1. This reduces the loss of Q5 and T3.

#### 3. PFC OVP Circuit

The comparator of IC2 (1/2) is an OVP circuit for protection when the  $V_{pfc}$  rises abnormally in the malfunction of the feedback system of the PFC CTRL.

Normally, the output of this comparator is "LOW". It becomes "HIGH" when OVP operates. Consequently, Pin 10 of IC1 (ENABLE pin) becomes "LOW" via the latch of Q3 and Q4 to stop the PFC switching. At the same time, D21 (red LED) is lit to inform of the error.

#### 4. Half Bridge Switching Regulator (Q6, Q7, T4, GA Board IC101, IC102)

The voltage obtained by dividing the PFC output voltage by two at C29 and C30 is used as the power supply of T5. The +B feedback voltage from IC101 of the G Board is given to IC102 of the GA board which is passed through isolator PC1. The PWM pulse generated at IC102 of the GA board is passed through the DRIVER IC (IC101) to switch between Q6 and Q7 alternately. As the result, +6V, -6V, +15V, -15V, and +B voltages are generated at the secondary side of T4.

#### 5. Power Supply Control

In the standby state, only the RCC switching regulator and PFC switching regulator operate. In this state, when the POWER ON signal from the sub CPU (IC7001) of the E board becomes "LOW", Q104 goes OFF, the LED inside the isolator PC2 lights up, and the photo-resistor turns ON. As Q12 is ON the rush current protection resistor R2 is short-circuited by RY2, Pin 5 of PC2 becomes "LOW", Q101 of the GA board goes OFF, IC101 oscillates, and H.B operates.

#### 6. PFC Failure Detection Circuit

The circuit which monitors if the PFC circuit is operating normally is composed of IC106, D113, D114, and other circuit parts.

The pulse generated at the secondary side of T3 (PFCT) is rectified by D113 and D114, input to the ⊕ terminal of the comparator (IC106 (2/2)), and compared with the reference voltage. When PFC is not operating, the comparator output (PFC FAILURE) becomes "LOW" because the comparator ⊕ terminal voltage cannot reach the reference voltage. Normally, D112 (green LED) is operated to indicate that operations are carried out normally.

#### 7. OVP (Over voltage protection), OCP (Over current protection) Circuits (GB)

##### • OVP (Over voltage protection) circuit

The voltage of each power supply line is compared with the reference voltage by the comparator of the GB board to detect over voltage.

The output of each comparator is normally "LOW" and becomes "HIGH" when errors occur.

##### • OCP (Over current protection) circuit

Over current is detected by supplying the voltage generated when the current detection resistor is inserted in each power supply line and current is passed through this resistor to the comparator of the GB board.

The output of each comparator is normally "LOW" and becomes "HIGH" when errors occur.

#### 8. SHUT DOWN Circuit (Q301 to Q312 of GB Board)

When the PFC FAILURE signal becomes "LOW" or when the OVP or OCP signal works so that the SHUT DOWN signal becomes HIGH, Q105 of the G board turns ON and the operations of the half bridge switching regulator stop. In this circuit, the OVP and OCP signals are latched and input to the encoder.

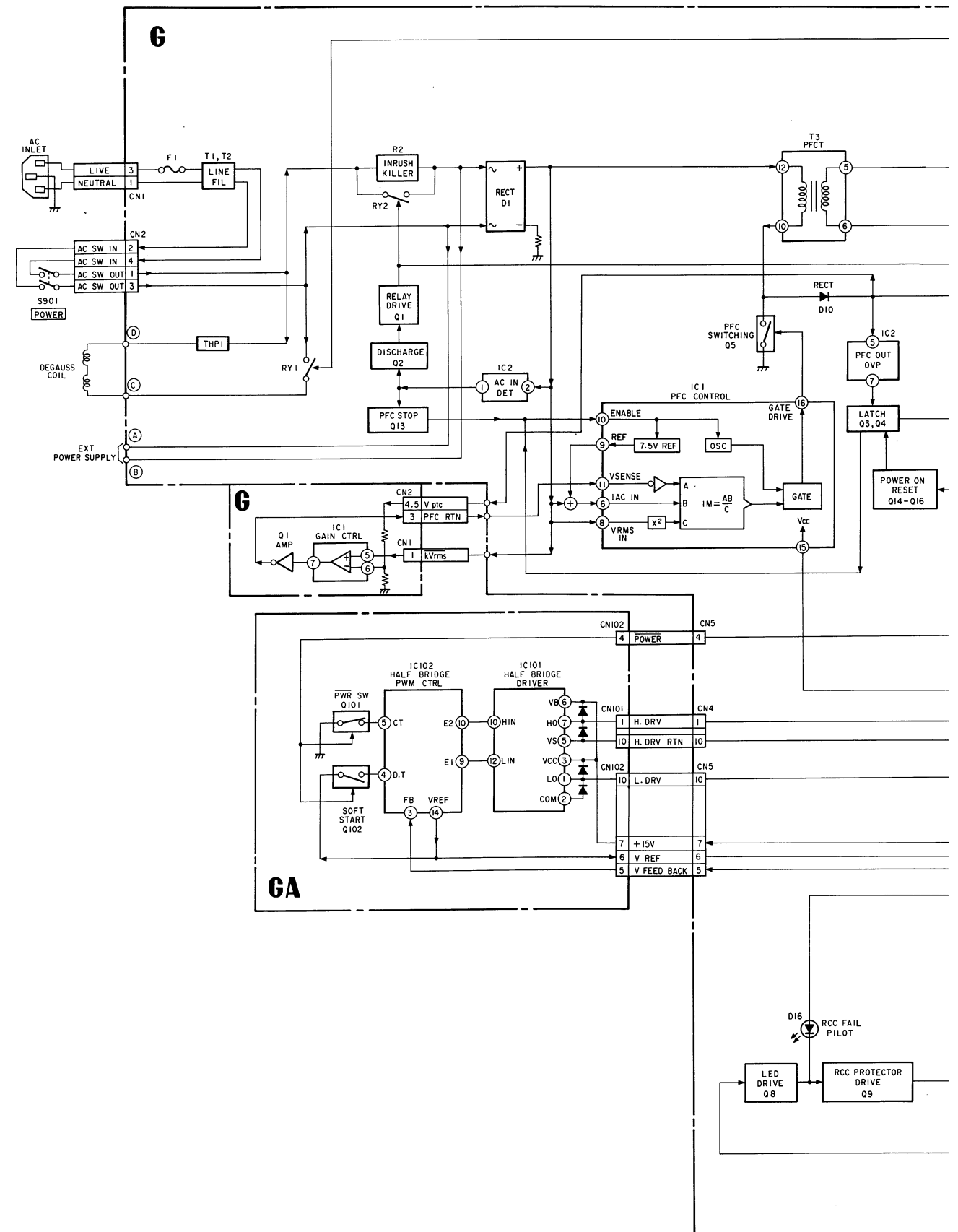
#### 9. Encoder (GB Board)

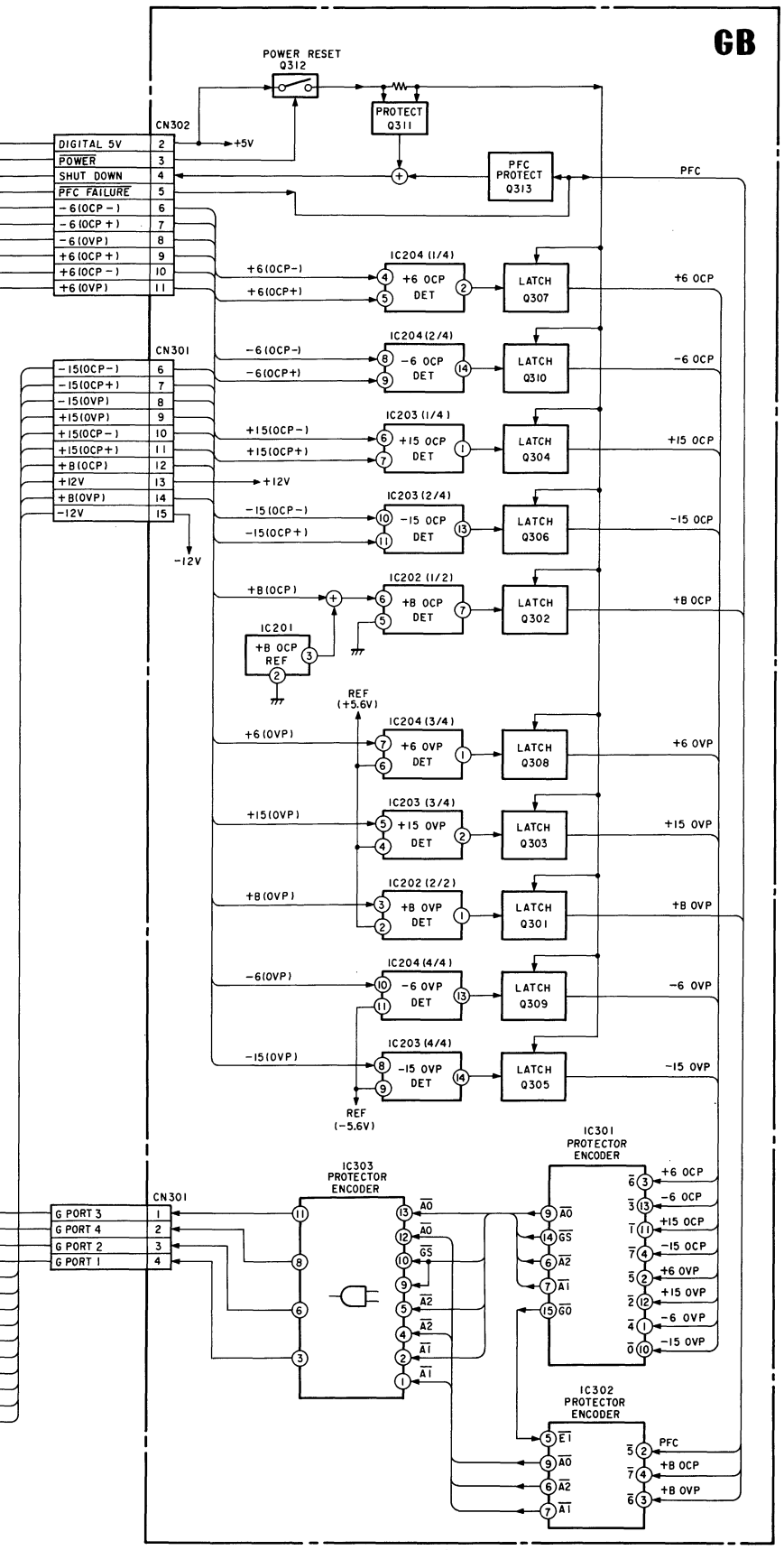
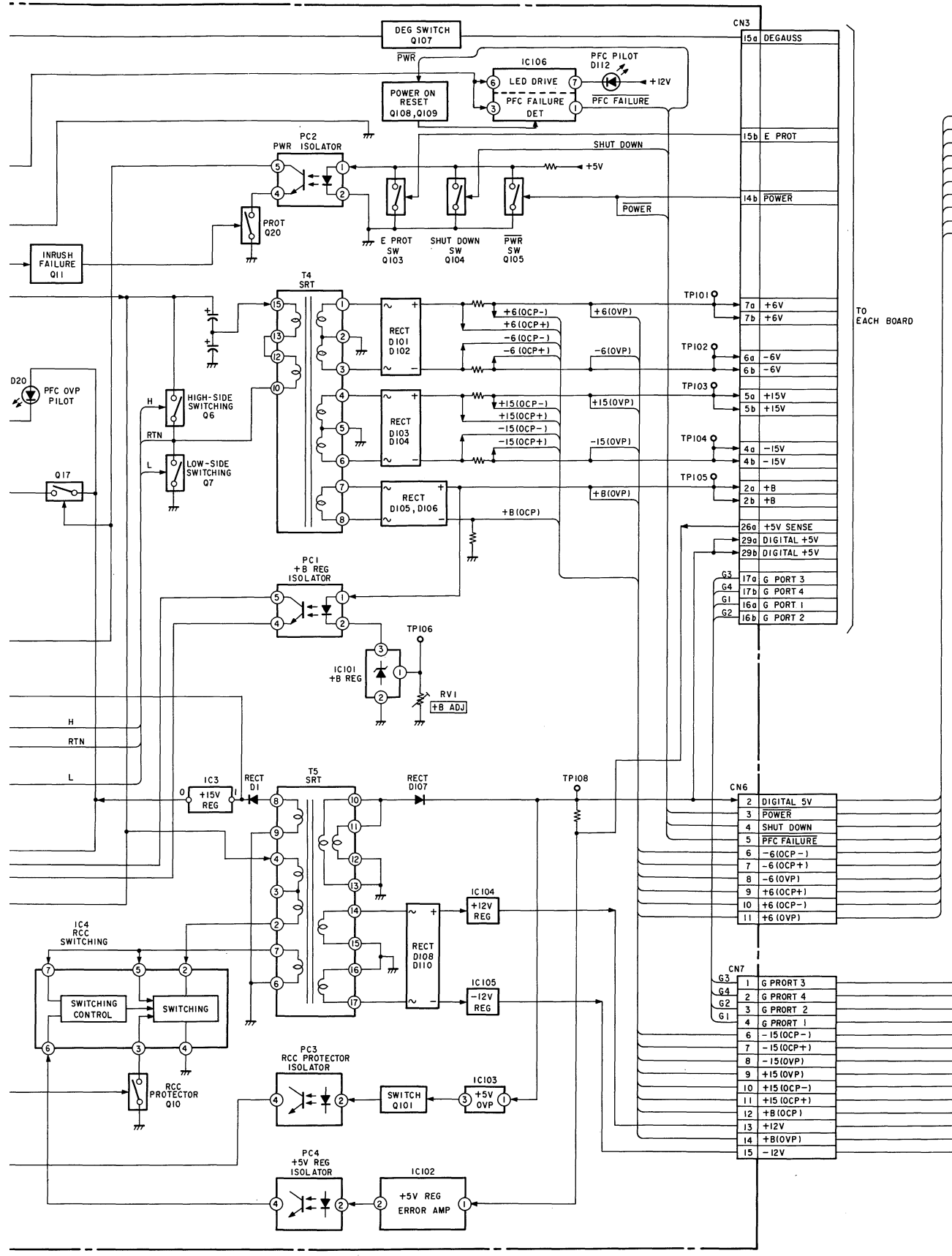
A total of 11 signals (5 OVP signals, 5 OCP signals, and one PFC FAILURE signal) are encoded into 4-bit signals, to inform the sub CPU (IC902) of the E board of errors.

#### 10. CRT Protector

If the horizontal/vertical deflection circuits stop due to some reason, the E PROT signal from the E board becomes "HIGH". As a result, Q103 of the G board turns ON and the operations of the half bridge switching regulator stop.

### G, GA, GB and GC Board Block Diagrams







# SECTION 4 ELECTRICAL ADJUSTMENTS

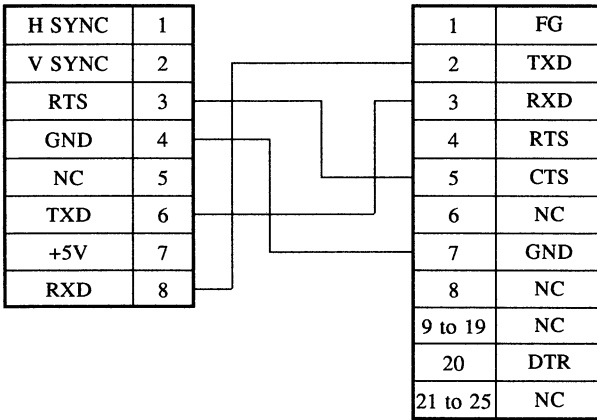
## 4-1. Basic Adjustments in Replacement of CRT

Perform the following adjustments when replacing the CRT.

### [Required Tools and Measuring Instruments]

1. Signal generator
2. Oscilloscope
3. Color analyzer (MINOLUTA CA-100)
4. Following specified cables for connecting RS-232C pin of CA-100 and OPTION pin of monitor.

BVM Option connector side      CA-100 RS-232C connector side  
Mini DIN 8pin      D Sub 25pin



### [Setting of INPUT CONFIGURATION Menu]

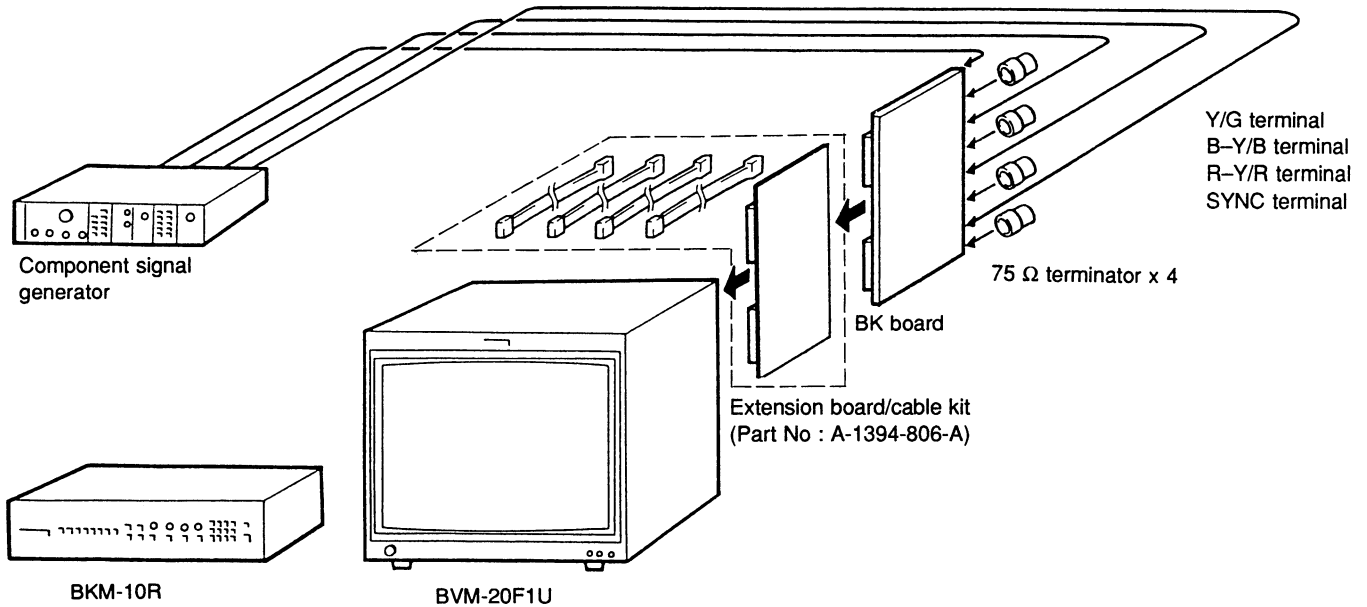
Unless specified otherwise, set the INPUT CONFIGURATION menu of the SETUP menu as follows.

```

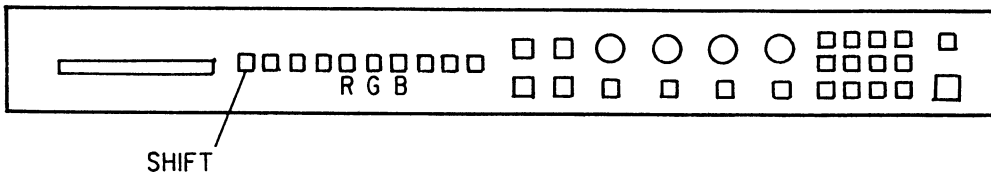
FORMAT.....COMPONENT YUV SMPTE/
                                EBU N-10

SLOT NO .....6
SYNC MODE .....INT
SCREEN MODE .....4 : 3 NORM
CONTROL .....CH SET
COLOR TEMP.....STD
H PHASE .....00
    
```

### • CONNECT



### Front Panel of BKM-10R



### [Focus Adjustment]

1. Input the dot signal or cross hatch signal.
2. Set the following DF adjustment data to the center value (128).

DF SIDE  
 DF CORNER  
 DF SIDE PHASE  
 DF T&B PHASE  
 DF T&B

**Note:** The above adjustment menu is under the E BOARD menu of the MAINTENANCE menu.

3. Adjust the center of the screen to the optimum focus using the FOCUS 1 VR (vertical focus adjustment) and FOCUS 2 VR (horizontal focus adjustment).
4. Input the cross hatch signal.
5. Adjust the following DF adjustment data so that the cross hatch lines at the ends of the screen become the same thickness as those at the center of the screen.

DF SIDE  
 DF CORNER  
 DF SIDE PHASE  
 DF T&B PHASE  
 DF T&B

6. Adjust the DF data in the same way in the following modes.  
 4 : 3 UNDERSCAN mode  
 16 : 9 NORMAL SCAN mode  
 16 : 9 UNDER SCAN mode

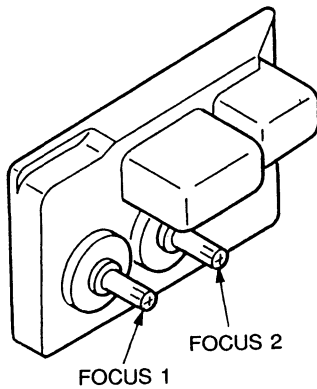


Fig. 1-1.

### [Landing Adjustment]

1. Input the white signal.
2. Press the BRIGHTNESS VR and CONTRAST VR buttons to the preset condition. (The LEDs (green) on the buttons go off.)
3. Face the CRT screen towards the east (west) and press the DEGAUSS button.
4. Set the Purity knob to the mechanical center.

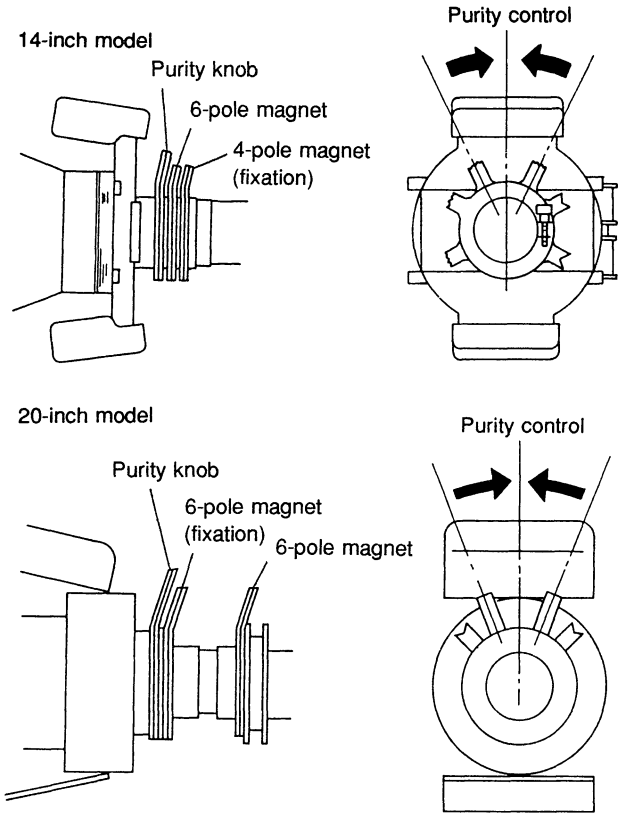


Fig. 1-2.

5. Push the DY (deflection yolk) to the front as much as possible.
6. Secure the neck assembly in the position shown in Fig. 1-3.

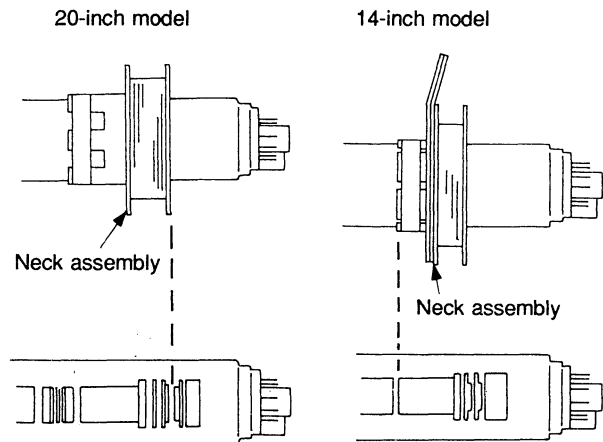


Fig. 1-3.

7. Set the color of the screen to green only (Turn on the SHIFT button (LED lights up in orange), and turn on the R button or B button (LED lights up).)
8. Rotate the Purity knob, and adjust so that the green comes to the center of the screen as shown in Fig. 1-4.

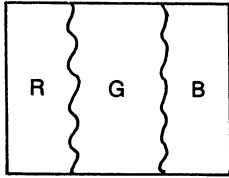


Fig. 1-4.

9. Move DY backwards, and adjust so that the color of the whole screen becomes green only.
10. Adjust the tilt of DY at cross hatch signal and tighten the screw of DY.
11. Secure the deflection yolk with four (20 Inch), three (14 Inch) spacers.

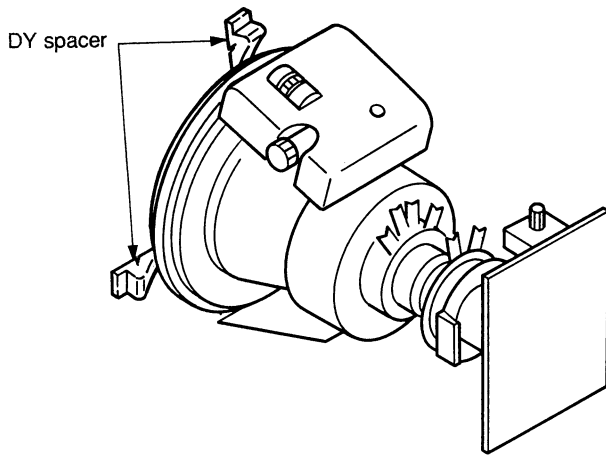


Fig. 1-5.

• Final check

After adjusting, check that there is no mislanding when the unit is faced in all four directions, north, south, east, west.

[H Blanking Adjustment]

• Preparations

1. Connect the signal generator and input the monoscope signal.
2. Increase BRIGHT until the blanking can be seen.

**Note:** The following adjustment menus are under the E BOARD menu of the MAINTENANCE menu.

- H BLK WIDTH
- H BLK PHASE
- H CENTER
- H PHASE
- H SIZE

• 4 : 3 NORMAL SCAN Mode H Blanking Adjustment

1. Set the SCREEN MODE to 4 : 3 NORM at the INPUT CONFIGURATION menu of the SETUP menu.
2. Decrease the H SIZE so that the whole left and right edges of the luster can be seen.
3. Maximize (255) the H BLK WIDTH data and H BLK PHASE data.
4. Adjust the H CENTER data so that the luster comes to the center of the screen (so that  $A \approx B$ ). Write down the H CENTER data at this time.
5. Adjust the H PHASE data so that the monoscope screen comes to the center of the luster (so that  $C \approx D$ ). Write down the H PHASE data.

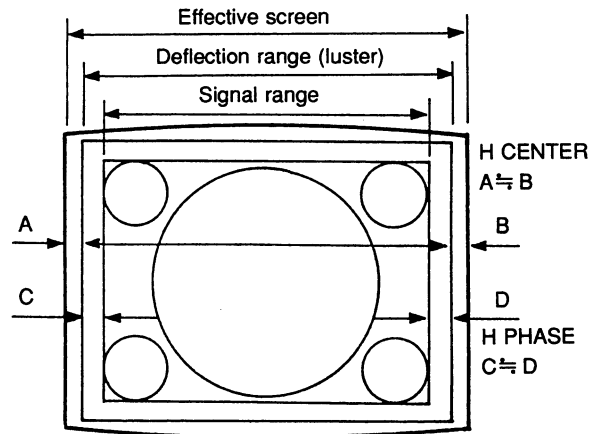


Fig. 1-6.

6. Adjust the H BLK PHASE data so that the outer right edge of the monoscope signal range is slightly chipped, and then adjust the data until the whole edge can be seen.
7. Set the H BLK PHASE data to +20.
8. Adjust the H BLK WIDTH data so that the outer left edge of the monoscope signal range is slightly chipped, and then adjust the data until the whole edge can be seen.
9. Set the H BLK WIDTH data to +20.
10. Set the original H SIZE.

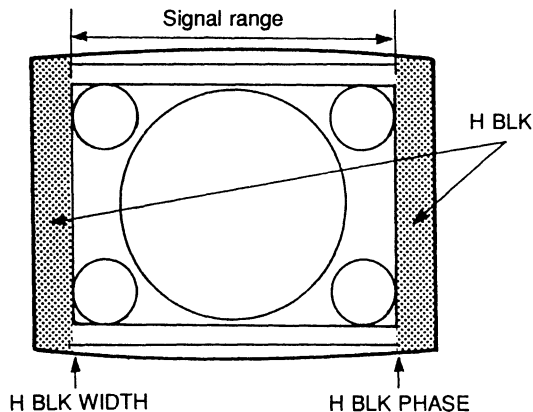


Fig. 1-7.

• 4 : 3 UNDER SCAN Mode H Blanking Adjustment

1. Set the SCREEN MODE to 4 : 3 UNDER at the INPUT CONFIGURATION menu of the SETUP menu.
2. Set the H CENTER data to the same value as the 4 : 3 NORMAL SCAN mode.
3. Set the H PHASE data to the same value as the 4 : 3 NORMAL SCAN mode.
4. Adjust the H BLK PHASE data until the blanking at the right side of the screen just disappears outside the effective screen.
5. Set the H BLK PHASE data to +20.
6. Adjust the H BLK WIDTH data until the blanking at the left side of the screen just disappears outside the effective screen.
7. Set the H BLK WIDTH data to +20.

• 16 : 9 NORMAL SCAN Mode H Blanking Adjustment

1. Set the SCREEN MODE to 16 : 9 NORM at the INPUT CONFIGURATION menu of the SETUP menu.
2. Set the H CENTER data to the same value as the 4 : 3 NORMAL SCAN mode.
3. Set the H PHASE data to the same value as the 4 : 3 NORMAL SCAN mode.
4. Adjust the H BLK PHASE data until the blanking at the right side of the screen just disappears outside the effective screen.
5. Set the H BLK PHASE data to +20.
6. Adjust the H BLK WIDTH data until the blanking at the left side of the screen just disappears outside the effective screen.
7. Set the H BLK WIDTH data to +20.

• 16 : 9 UNDER SCAN Mode H Blanking Adjustment

1. Set the SCREEN MODE to 16 : 9 UNDER at the INPUT CONFIGURATION menu of the SETUP menu.
2. Set the H CENTER data to the same value as the 4 : 3 NORMAL SCAN mode.
3. Set the H PHASE data to the same value as the 4 : 3 NORMAL SCAN mode.
4. Adjust the H BLK PHASE data until the blanking at the right side of the screen just disappears outside the effective screen.
5. Set the H BLK PHASE data to +20.
6. Adjust the H BLK WIDTH data until the blanking at the left side of the screen just disappears outside the effective screen.
7. Set the H BLK WIDTH data to +20.



## [V Blanking Adjustment]

### • Preparations

1. Connect the signal generator and input the monoscope signal.
2. Set the H DELAY mode and increase BRIGHT.

**Note:** The following adjustment menus are under the E BOARD menu of the MAINTENANCE menu.

V BLK TOP  
V BLK BOT  
V ITS BLK

### • 4 : 3 NORMAL SCAN Mode V Blanking Adjustment

1. Set the SCREEN MODE to 4 : 3 NORM at the INPUT CONFIGURATION menu of the SETUP menu.
2. Adjust the V BLK TOP data until the blanking at the top of the screen just disappears outside the effective screen.
3. Set the V BLK TOP data to +30.
4. Adjust the V BLK BOTTOM data until the blanking at the bottom of the screen just disappears outside the effective screen.
5. Set the V BLK BOTTOM data to -30.
6. Set the V BLK P POS data to 255.

### • 4 : 3 UNDER SCAN Mode V Blanking Adjustment

1. Set the SCREEN MODE to 4 : 3 UNDER at the INPUT CONFIGURATION menu of the SETUP menu.
2. Set the V BLK TOP data to the same value as the 4 : 3 NORMAL SCAN mode.
3. Set the V BLK BOTTOM data to the same value as the 4 : 3 NORMAL SCAN mode.
4. Adjust the V BLK POS data to 255.

### • 16 : 9 NORMAL SCAN Mode V Blanking Adjustment

1. Set the SCREEN MODE to 16 : 9 NORM at the INPUT CONFIGURATION menu of the SETUP menu.
2. Set the V BLK TOP data to 255.
3. Set the V BLK BOTTOM data to 00.
4. Set the V BLK P POS data to 255.

### • 16 : 9 UNDER SCAN Mode V Blanking Adjustment

1. Set the SCREEN MODE to 16 : 9 UNDER at the INPUT CONFIGURATION menu of the SETUP menu.
2. Set the V BLK TOP data to 255.
3. Set the V BLK BOTTOM data to 00.
4. Set the V BLK P POS data to 255.

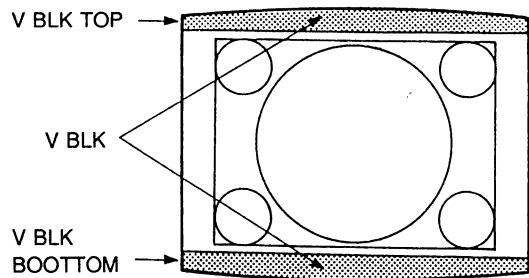


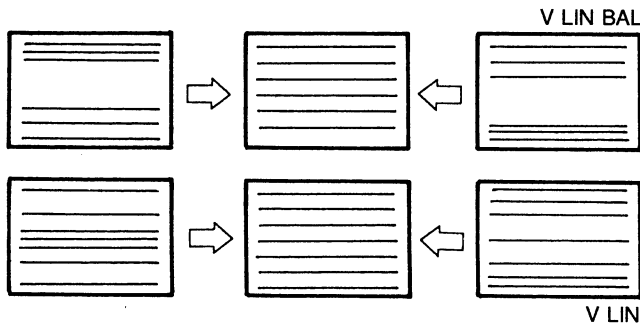
Fig. 1-8.

**[Linearity Adjustment]**

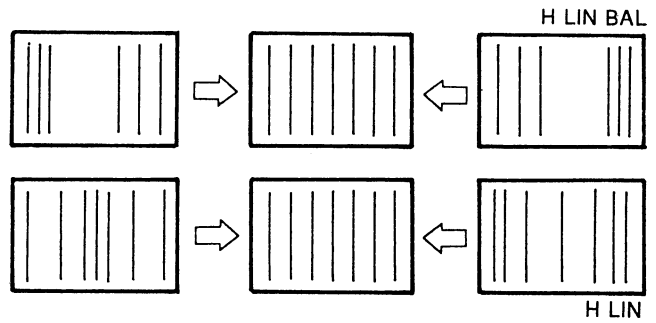
**Note:** The following adjustment menus are under the E BOARD menu of the MAINTENANCE menu.

- H PHASE
- V CENTER
- H LIN BAL
- H LIN
- V LIN BAL
- V LIN AMP
- H KEY BAL
- H KEY
- H PIN BAL
- H PIN
- H CENTER PIN
- H MID PIN
- H CORNER PIN

1. Input the cross hatch signal.
2. Check that the image is not tilting, and there is no top and bottom PIN distortion nor horizontal trapezoid distortion.  
 Tilt : Adjust the DY tilt.  
 Top/bottom Pin distortion : Adjust the top and bottom DY head swing  
 Horizontal trapezoid distortion : Adjust using the DY TLV VR (take note that the convergence may be disrupted.)
3. Input the monoscope signal.
4. Set the SCREEN MODE to 4 : 3 NORM at the INPUT CONFIGURATION menu.
5. Adjust the H PHASE data, and adjust the horizontal center of the image.
6. Adjust the vertical center of the image.
7. Input the cross hatch signal.
8. Adjust the V SIZE, V LIN BAL, and V LIN data as shown in Fig. 1-9.
9. Adjust the H SIZE, H LIN BAL, and H LIN data as shown in Fig. 1-10.

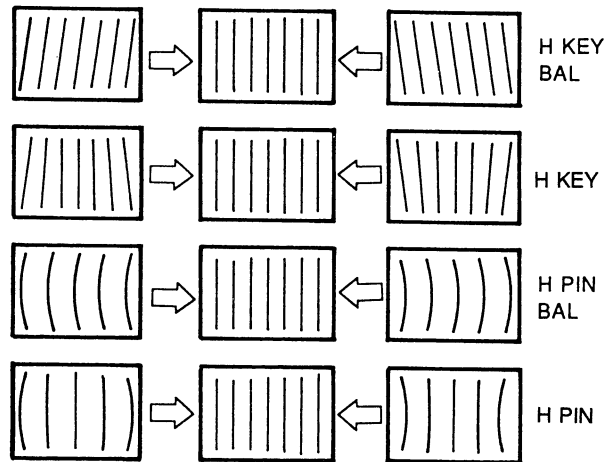


**Fig. 1-9.**

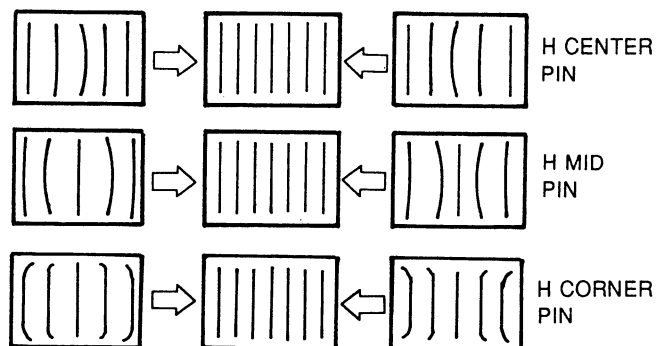


**Fig. 1-10.**

10. Adjust the H KEY BAL, H KEY, H PIN BAL, and H PIN data so that there is no side trapezoid distortion and PIN distortion as shown in Fig. 1-11.
11. Adjust the H CENTER PIN, H MID PIN, and H CORNER PIN data as shown in Fig. 1-12.
12. Repeat the above adjustment to optimize the horizontal and vertical linearity.
13. Adjust in the same way in the following modes.  
 4 : 3 UNDER SCAN mode  
 16 : 0 NORMAL SCAN mode  
 16 : 9 UNDER SCAN mode



**Fig. 1-11.**



**Fig. 1-12.**

## [Convergence Adjustment]

### • Preparation

1. Set the SCREEN MODE to 4:3 NORM at the INPUT CONFIGURATION menu.
2. Input the cross hatch signal.
3. Check that the H STAT data is the center value (128).

**Note:** The H STAT adjustment menu is under the E BOARD menu of the MAINTENANCE menu.

4. For the 14 inch model, set the 4-pole magnet of the DY to the OFFSET state.
5. For the 20 inch model, set the 6-pole magnet of the DY to the OFFSET state.

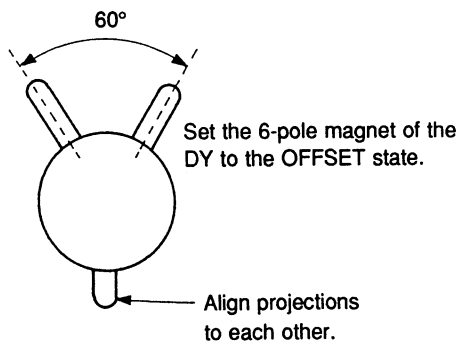


Fig. 1-13.

## [Static Convergence Adjustment]

### • Horizontal Static Convergence

1. Adjust RV1 (H STAT) of the C board so that the red and green dots coincide in the horizontal direction at the screen center.
2. If the blue dot is out of convergence from the red and green dots:
  - For the 14-inch model: Perform HMC (horizontal misconvergence) correction using the 6-pole magnet of the DY (See Fig. 1-2.). (The 4-pole magnet of the DY is not used. Set to the OFFSET state.)
  - For the 20-inch model: Perform HMC (horizontal misconvergence) correction using the 6-pole magnet of the NTC (See Fig. 1-2.). (The 6-pole magnet of the DY is not used. Set to the OFFSET state.)

### • Vertical Static Convergence

1. Adjust the V STATIC CONV data so that the red and green dots coincide in the vertical direction at the screen center.
 

**Note:** The V STATIC CONV adjustment menu is under the E BOARD menu of the MAINTENANCE menu.
2. If the blue dot is out of convergence from the red and green dots:
  - For the 14-inch model: Perform VMC (vertical misconvergence) correction using the 6-pole magnet of the DY (See Fig. 1-2.). (The 4-pole magnet of the DY is not used. Set to the OFFSET state.)
  - For the 20-inch model: Perform VMC correction using the 6-pole magnet of the NTC (See Fig. 1-2.). (The 6-pole magnet of the DY is not used. Set to the OFFSET state.)

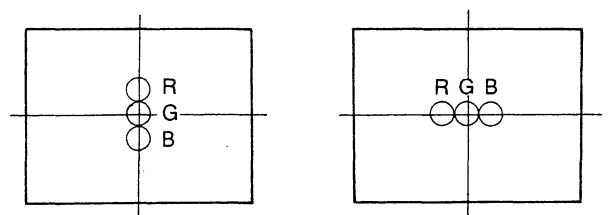


Fig. 1-14.

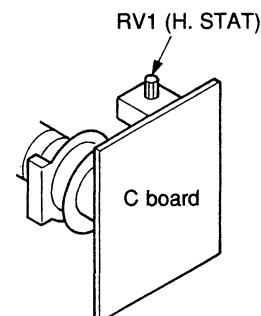
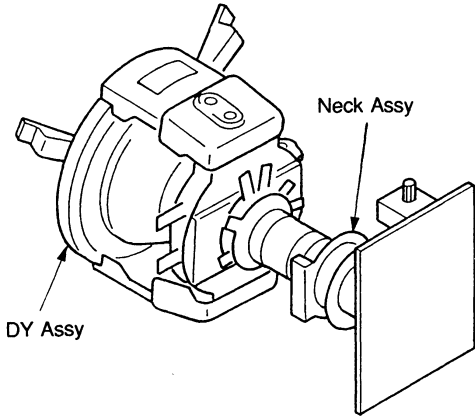


Fig. 1-15.

14-inch model



20-inch model

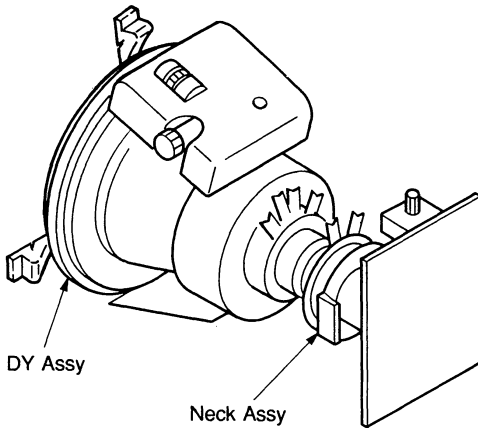


Fig. 1-16.

**[20-inch Model Convergence Adjustment]**

• Preparation

1. Set the SCREEN MODE to 4 : 3 NORM at the INPUT CONFIGURATION menu.
2. Input the cross hatch signal.

• Vertical Convergence Adjustment

1. Minimize the vertical misconvergence at the center of the left side of the screen and the center of the right side of the screen using the DY correction reactors XB V and XCV.
2. Minimize the vertical misconvergence at the top and bottom of the screen using the DY correction reactor TLV.
3. Adjust the V CONV TOP data and V CONV BOT data so that the vertical misconvergence at the top and bottom of the screen becomes minimum.

**Note:** The V CONV TOP and V CONV BOT adjustment menu is under the E BOARD menu of the MAINTENANCE menu.

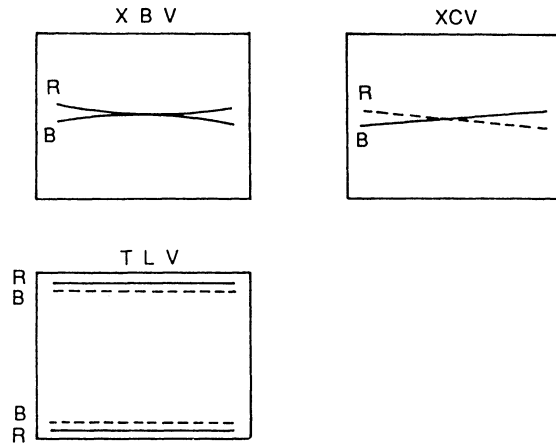


Fig. 1-19.

• HMC and VMC correction with 6-pole magnet

1. HMC (horizontal misconvergence) correction of 6-pole magnet and movement of electron beam.

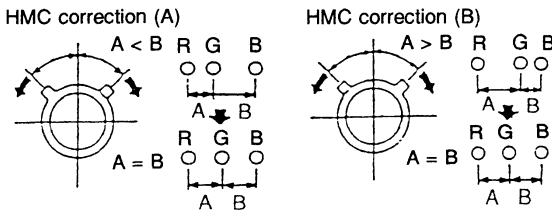


Fig. 1-17.

2. VMC (vertical misconvergence) correction of 6-pole magnet and movement of electron beam.

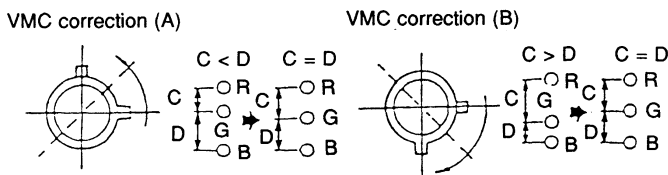


Fig. 1-18.

• Horizontal Convergence Adjustment

1. Adjust the horizontal convergence adjustment data (H CONV data) in the following order so that the red, green, and blue dots coincide on the whole screen.

(Do not change the value of the H STAT data (128).)

**Note:** The horizontal convergence adjustment menu is under the E BOARD menu of the MAINTENANCE menu.

1. H CONV C T
2. H CONV C B
3. H CV C M T
4. H CV C M B
5. H CV L C
6. H CV L T
7. H CV L B
8. H CV L M T
9. H CV L M B
10. H CV R C
11. H CV R T
12. H CV R B
13. H CV R M T
14. H CV R M B

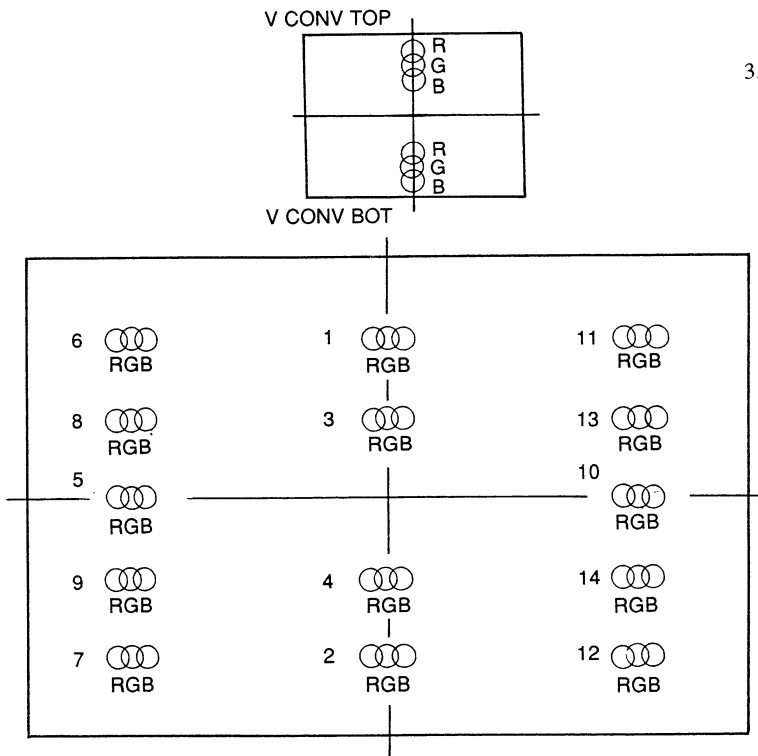


Fig. 1-20.

• 4 : 3 UNDER SCAN Mode Convergence Adjustment

1. Set the SCREEN MODE to 4 : 3 UNDER at the INPUT CONFIGURATION menu of the SETUP menu.
2. Set the vertical convergence adjustment data (V CONV data) and horizontal convergence adjustment data (H CONV data) to the same value as the 4 : 3 NORMAL SCAN mode.
3. Check the horizontal and vertical convergence, and if there is misconvergence, adjust again.

• 16 : 9 NORMAL SCAN Mode Convergence Adjustment

1. Set the SCREEN MODE to 16 : 9 NORM at the INPUT CONFIGURATION menu of the SETUP menu.
2. Set the vertical convergence adjustment data (V CONV data) and horizontal convergence adjustment data (H CONV data) to the same value as the 4 : 3 NORMAL SCAN mode.
3. Check the horizontal and vertical convergence, and if there is misconvergence, adjust again.

• 16 : 9 UNDER SCAN Mode Convergence Adjustment

1. Set the SCREEN MODE to 16 : 9 UNDER at the INPUT CONFIGURATION menu of the SETUP menu.
2. Set the vertical convergence adjustment data (V CONV data) and horizontal convergence adjustment data (H CONV data) to the same value as the 4 : 3 NORMAL SCAN mode.
3. Check the horizontal and vertical convergence, and if there is misconvergence, adjust again.

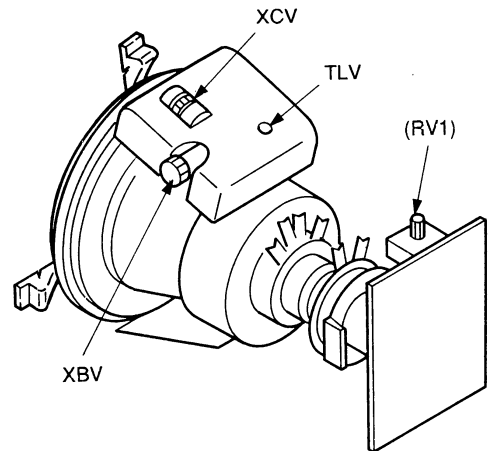


Fig. 1-21.

## [14-inch Model Convergence Adjustment]

### • Preparation

1. Set the SCREEN MODE to 4 : 3 NORM at the INPUT CONFIGURATION menu.
2. Input the cross hatch signal.

### • Convergence Adjustment

1. Minimize the vertical misconvergence at the center of the left side of the screen and the center of the right side of the screen using the DY correction reactor XCV (TH).
2. Minimize the vertical misconvergence at the top and bottom of the screen using the DY correction reactor TLV.
3. Adjust the V CONV TOP data and V CONV BOT data so that the vertical misconvergence at the top and bottom of the screen becomes minimum.

(Do not change the value of the H STAT data and H CONV data (128).)

**Note:** The V CONV TOP and V CONV BOT adjustment menus are under the E BOARD menu of the MAINTENANCE menu.

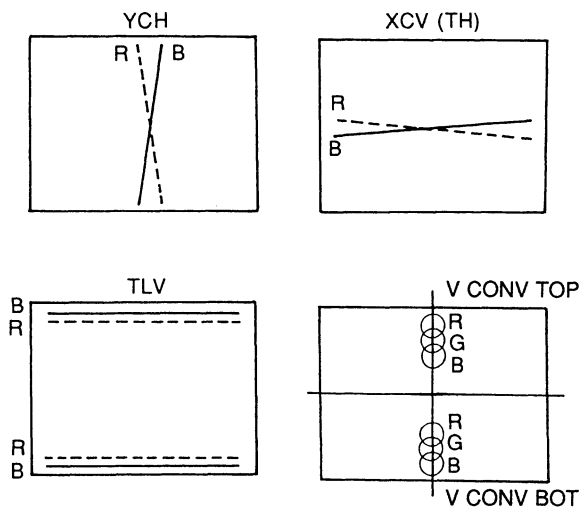


Fig. 1-22.

### • 4 : 3 UNDER SCAN Mode Convergence Adjustment

1. Set the SCREEN MODE to 4 : 3 UNDER at the INPUT CONFIGURATION menu of the SETUP menu.
2. Set the vertical convergence adjustment data (V CONV data) to the same value as the 4 : 3 NORMAL SCAN mode.
3. Check the horizontal and vertical convergence, and if there is misconvergence, adjust again.

### • 16 : 9 NORMAL SCAN Mode Convergence Adjustment

1. Set the SCREEN MODE to 16 : 9 NORM at the INPUT CONFIGURATION menu of the SETUP menu.
2. Set the vertical convergence adjustment data (V CONV data) to the same value as the 4 : 3 NORMAL SCAN mode.
3. Check the horizontal and vertical convergence, and if there is misconvergence, adjust again.

### • 16 : 9 UNDER SCAN Mode Convergence Adjustment

1. Set the SCREEN MODE to 16 : 9 UNDER at the INPUT CONFIGURATION menu of the SETUP menu.
2. Set the vertical convergence adjustment data (V CONV data) to the same value as the 4 : 3 NORMAL SCAN mode.
3. Check the horizontal and vertical convergence, and if there is misconvergence, adjust again.

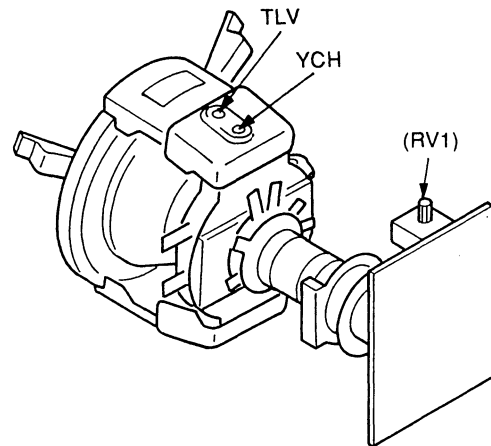


Fig. 1-23.

### [G2 Adjustment]

**Note:** The G2 REF Adjustment menu is under the BK BOARD menu of the MAINTENANCE menu.

1. Input the color bar signal.
2. Connect the R, G, and B cathodes of the C board to the probes of the oscilloscope, and check the DC voltage of the color bar signal pedestal.  
(20V/Div)
3. Connect the cathode with the highest pedestal DC voltage to the probe of the oscilloscope.
4. Adjust the G2 REF data so that the pedestal DC voltage becomes 97.5V.

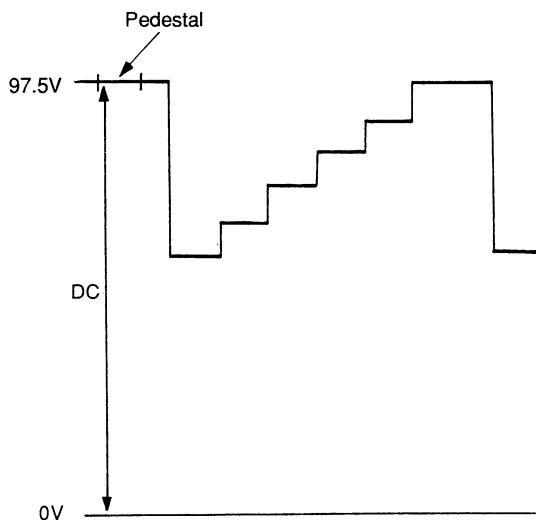


Fig. 1-24.

### — C Board — <Conductor side>

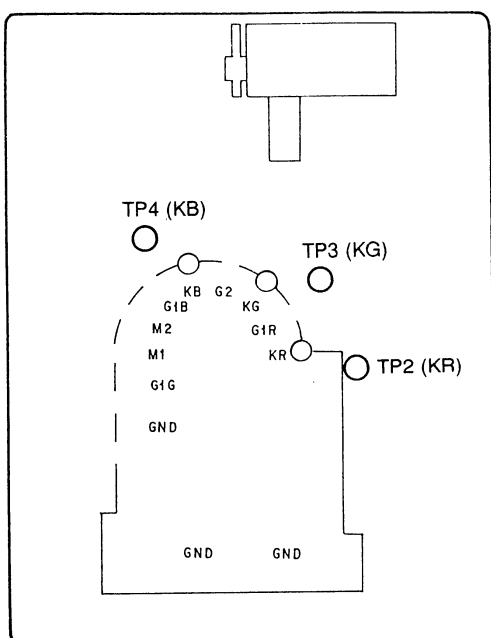


Fig. 1-25.

### [White Balance Adjustment]

1. Outline of Adjustments and Calibration of Color Analyzer Used for Adjustments

Perform the following adjustments.

#### 1.1 Creating the parameters used for converting the CRT RGB drive voltage into color temperature coordinates

This monitor is equipped with a function for copying color temperature between several monitors.

Because the CRT drive voltage depends on the CRT, the same color temperature will not be attained amongst several monitors even if the same drive voltage has been supplied. For this reason, to copy a color temperature between several monitors, it is necessary to send the required data using parameters which do not depend on the CRT such as the xyY color temperature coordinates.

Select and execute the SYSTEM/COLOR TEMP/FACTORY ADJ menu on the MAINTENANCE menu. The D93 color temperature will automatically be adjusted and at the same time, the drive voltage and color temperature coordinates conversion parameter will be created.

Use this parameter for copying the color temperature to other monitors and for copying the color temperature to the memory card.

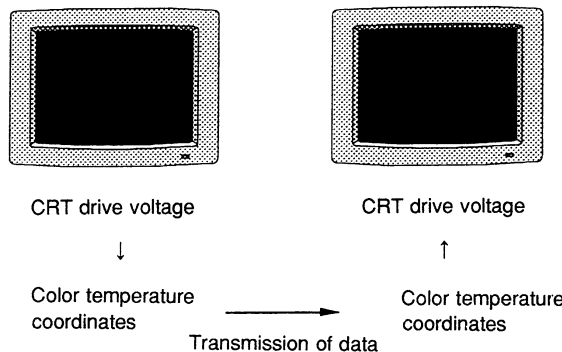


Fig. 1-26.

#### 1.2 D65/D56 Color Temperature Adjustment

Perform the D56 adjustment only for BVM-14E1U/14E5U/14F1U/14F5U/20E1U/20F1U.

#### 1.3 Copying Color Temperature Data D65/D93/D56 to Color Temperature STD, COLOR1, COLOR2, AUX

#### Calibration of Color Analyzer

Generally, to measure the color temperature of a monitor using several color analyzers, these color analyzers will show different values. The values measured by the color analyzer will also change with time. For this reason, color analyzers used for this adjustment should be calibrated first so that they will show the correct values for the following color temperature coordinates.

	x	y	Y (cd/m <sup>2</sup> )
D65	0.313	0.329	2.7
	0.313	0.329	100
D93	0.284	0.298	2.7
	0.284	0.298	100
D56	0.331	0.346	2.7
	0.331	0.346	100

## 2. Adjustment Standard

2.1 Input the following signal to the G/Y input terminal of the BK board to display it on the screen.

For BVM-14E1U/14E5U/14F1U/14F5U/20E1U/20F1U : NTSC signal

For BVM-14E1E/14E5E/14F1E/14F5E/20E1E/20F1E : PAL signal

2.2 Connect the RS-232C terminal of the CA-100 with the OPTION terminal of the monitor using the cable shown in "Required Tools and Measuring Instruments 5."

2.3 Set the CA-100 as shown below, and connect the measuring probe of the CA-100 at the center of the CRT screen.

Display mode : xyY mode

Baud Rate : 9600

3. Select the SYSTEM/COLOR TEMP menu on the MAINTENANCE menu.

4. Select D93 of COLOR TEMP, cover the CRT screen with a black cloth, select FACTORY ADJ, and start automatic adjustments.

5. Select D65 of COLOR TEMP, and select the PROBE/MINOLTA CA-100 menu. After selecting D65, cover the CRT screen with a black cloth, and select START to start automatic operations.

6. Execute this adjustment only for BVM-14E1U/14E5U/14F1U/14F5U/20E1U/20F1U.

Select AUX of COLOR TEMP, and select the PROBE/MINOLTA CA-100 menu.

After setting X=0.331, Y=0.346, LOWLIGHT=2.7, and HIGHLIGHT=100, cover the CRT screen with a black cloth, and select START to start automatic operations.

7. Select the SYSTEM/COLOR TEMP/COPY/OTHER VALUE menu on the MAINTENANCE menu.

8. Select STD of COLOR TEMP, perform the following "D65", and copy the color temperature data to STD.

9. Select COLOR1 of COLOR TEMP, perform the following "D93", and copy the color temperature data to COLOR1.

10. Select COLOR2 of COLOR TEMP, perform the following step, and copy the color temperature data to COLOR2.

For BVM-14E1U/14E5U/14F1U/14F5U/20E1U/20F1U : Select AUX

For BVM-14E1E/14E5E/14F1E/14F5E/20E1E/20F1E : Select D65

11. Execute this adjustment only for BVM-14E1E/14E5E/14F1E/14F5E/20E1E/20F1E.

Select AUX of COLOR TEMP, perform the following "D65", and copy the color temperature data to AUX.

## 4-2. SAFETY RELATED ADJUSTMENTS

### **+B (120V) Voltage Adjustment** (RV101)

Perform the following checks/adjustments when replacing the following components (marked ■ on the schematic diagram).

■G board .....RV101, R115, R116, R119, R120, R121, R122, IC101, PC1  
GA board .....R111, IC102

1. Connect a digital voltmeter to TP105 of the G board.  
(GND : TP107 of G board)
  - Digital voltmeter : More than 4 digits
2. Input the cross hatch signal.
3. Set the BRIGHTNESS VR and CONTRAST VR buttons to the preset condition. (The LEDs (green) on the buttons go off.)
4. Rotate RV101 of the G board in the clockwise direction to maximize the TP105 voltage.  
Check that the TP105 voltage is 126.0 V ± 6.0 V.
5. Adjust the TP105 voltage to 120.0 V ± 0.5 V using RV101 of the G board.

### **High Voltage Regulator Check/Adjustment**

#### (RV501)

Perform the following checks/adjustments when replacing the following components (marked • on the schematic diagram).

■PA board ....RV501, IC501, R509, R510, R513, R801, R802, R804

1. Turn off the power.
2. Connect a static voltmeter to the CRT anode cap.
  - Static voltmeter : Whose input impedance calibrated to above  $2 \times 10^9 \Omega$ .  
(Example : Singer's ESH-27X or ESH-23X)
3. Turn on the power.
4. Input the monoscope signal.
5. Set the BRIGHTNESS VR and CONTRAST VR buttons to the preset condition. (The LEDs (green) on the buttons go off.)
4. Check that the voltage value is within the following ranges.  
20-inch model : 27.00 kV ± 0.15 kV  
14-inch model : 25.00 kV ± 0.15 kV
5. If step 4 is not satisfied, replace RV501 of the PA board, adjust RV501 so that the specification is satisfied.
6. If replacing RV501 in step 5, after adjusting the RV, secure RV501 using epoxy resin (DP-190 3M).



### High Voltage Hold-down Check/Adjustment

#### (RV503)

Perform the following checks/adjustments when replacing the following components (marked ■ on the schematic diagram).

■ PA board ....RV503, IC502, R524, R525, R526, R527, R530, R808

1. Turn off the power.
2. Connect the static voltmeter to the CRT anode cap.
  - Static voltmeter : Whose input impedance calibrated to above  $2 \times 10^9 \Omega$ .  
(Example : Singer's ESH-27X or ESH-23X)
3. Connect a 200 k $\Omega$  variable resistor between TP501 and GND of the PA board.  
(Maximize the resistance of the 200 k $\Omega$  variable resistor.)
4. Turn on the power.
5. Input the cross hatch signal.
6. Set the BRIGHTNESS VR and CONTRAST VR buttons to the preset condition. (The LEDs (green) on the buttons go off.)
7. Cut-off R, G, and B. (Turn on the SHIFT button (LED lights up in orange), and turn on the R, G, and B buttons (LEDS light up).)
8. Check that when the resistance of the 200 k $\Omega$  variable resistor connected to TP501 is gradually reduced, the high voltage drops rapidly at the following values.
  - 20-inch model : 30.00 kV  $\pm$  0.50 kV
  - 14-inch model : 27.00 kV  $\pm$  0.50 kV
9. If step 8 is not satisfied, replace RV503 of the PA board, and adjust RV503 so that the specification is satisfied.
10. Disconnect the 200 k $\Omega$  variable resistor.
11. Check that the high voltage satisfies the following values.
  - 20-inch model : 27.00 kV  $\pm$  0.15 kV
  - 14-inch model : 25.00 kV  $\pm$  0.15 kV
12. Disconnect the static voltmeter.
13. If replacing RV503 in step 9, after adjusting the RV, secure RV503 using epoxy resin (DP-190 3M).

### Beam Current Protector Check/Adjustment

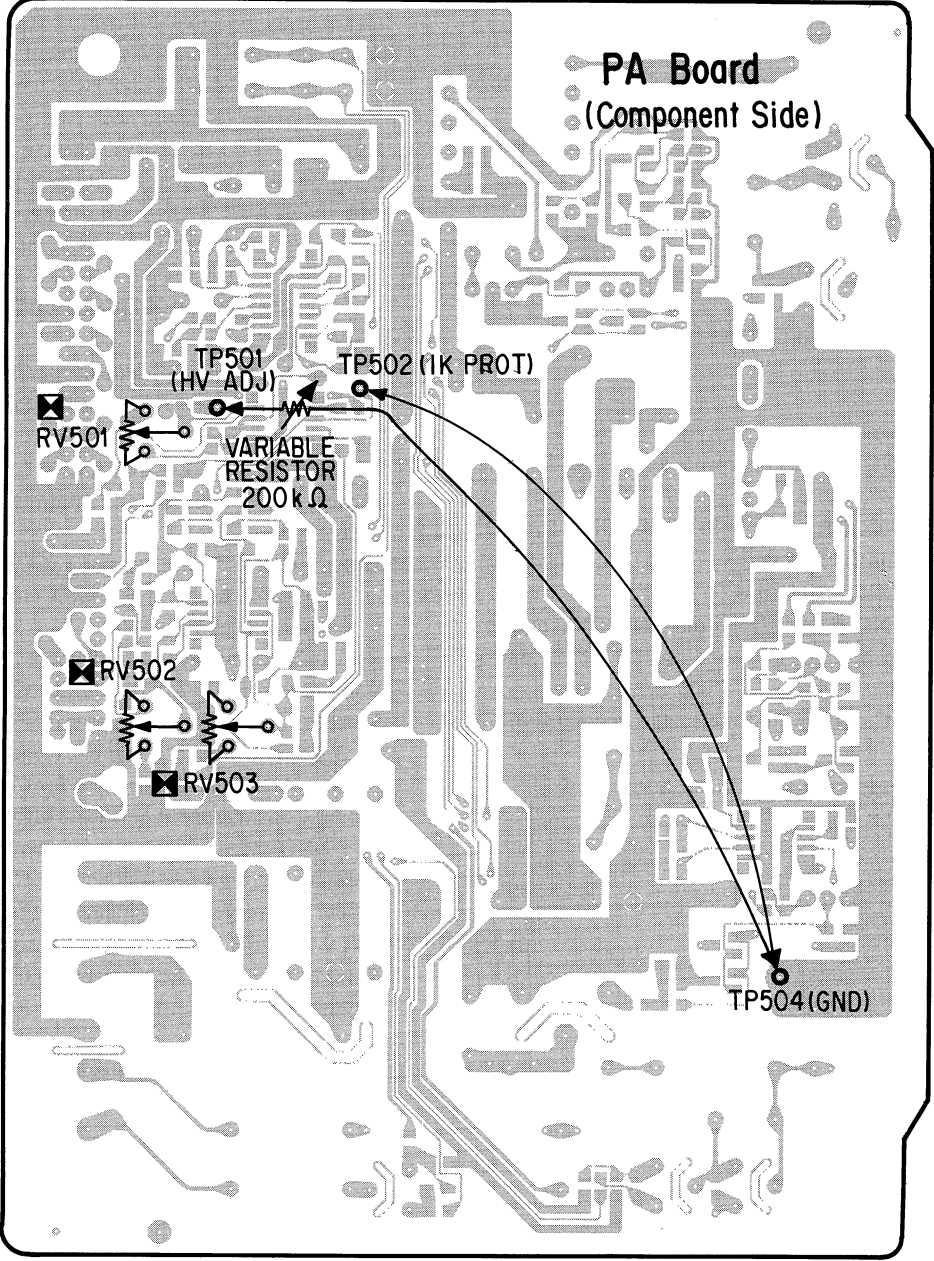
#### (RV502)

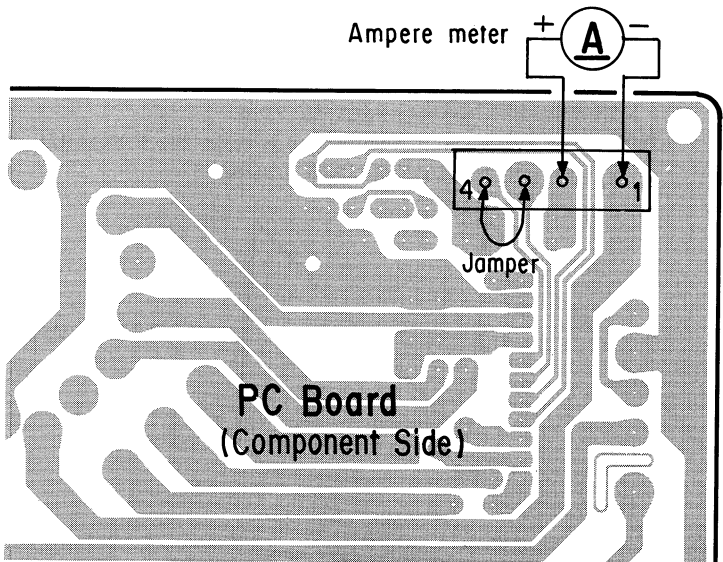
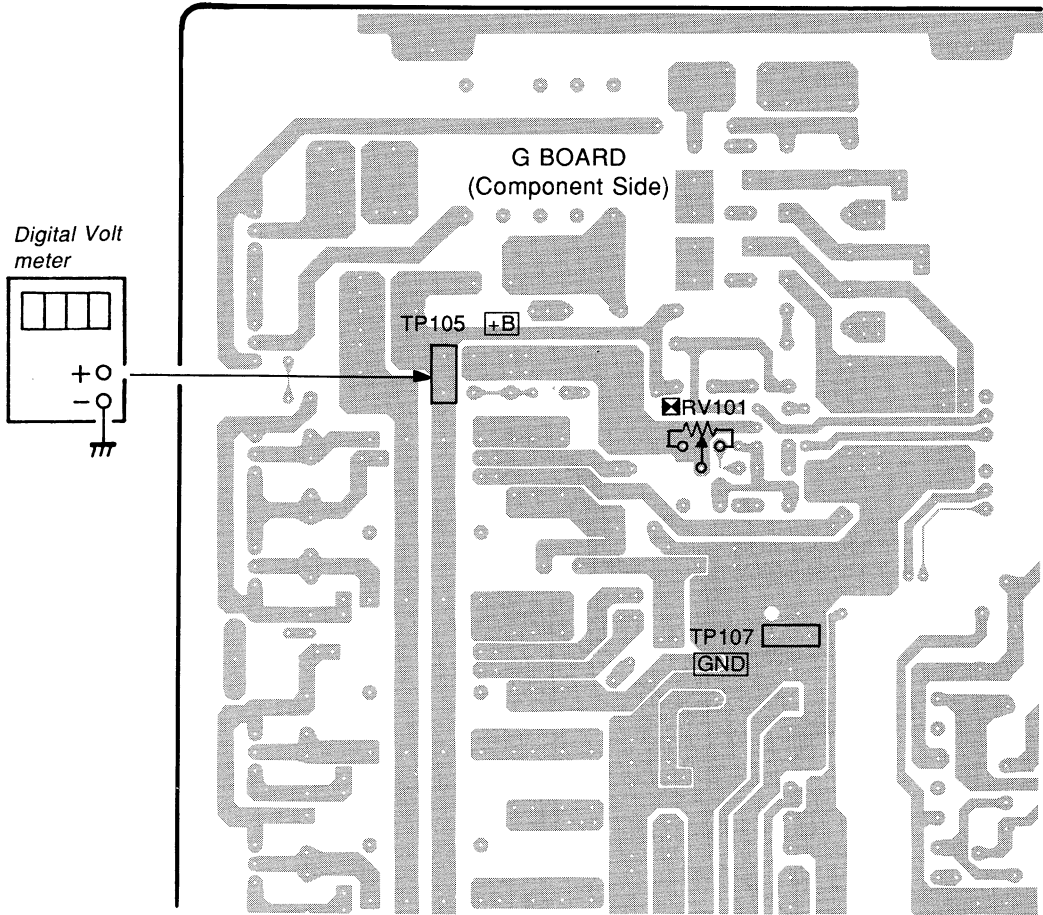
Perform the following checks/adjustments when replacing the following components (marked • on the schematic diagram).

■ PA board ....RV502, IC502, R101, R514, R515, R516, R517  
PC board ....R1, R2, R3, R4, R5, R6  
BK board ....R912, R913, IC901

1. Turn off the power.
2. Disconnect the CN3 connector of the PC board.
3. Connect a DC ammeter between Pins ① and ② of CN3 of the PC board.
4. Short-circuit Pin ③ and ④ of CN3 using a jumper.
5. Short-circuit TP502 and TP504 (GND) of the PA board using a jumper.
6. Turn on the power.
7. Input the 100% all-white signal.
8. Set the BRIGHTNESS VR and CONTRAST VR buttons to set the MANUAL adjustment condition. (The LEDs (green) on the buttons light up.)
9. Gradually rotate the BRIGHTNESS VR and CONTRAST VR from MIN to MAX, and check that the protector starts operating when the readings of the ammeter becomes as follows.
  - 20-inch model : 2.0 mA  $\pm$  0.2 mA
  - 14-inch model : 1.5 mA  $\pm$  0.2 mA
10. Replace RV502 if step 9 is not satisfied, adjust RV502 so that the specification is satisfied.
11. Disconnect the jumper between TP502 and TP504 (GND) of the PA board.
12. Turn on the power again.
13. Check that when the BRIGHTNESS VR and CONTRAST VR buttons are rotated from MIN to MAX, ABL operates (the reading of the ammeter is as follows).
  - 20-inch model : Below 1.5 mA
  - 14-inch model : Below 1.3 mA
14. Disconnect the DC ammeter.
15. Disconnect the jumper between Pins ③ and ④ of CN3 of the PC board.
16. Connect the CN3 connector of the PC board.
17. If RV502 is replaced at step 10, after adjusting the RV, secure it with epoxy resin (DP-190 3M).

PA Board  
(Component Side)





## 4-3. ELECTRICAL ADJUSTMENTS

### 1. E Board Adjustment

#### 1-1. Adjust Preparation

Set as follows at the INPUT CONFIGURATION menu of the SETUP menu.

FORMAT ..... COMPONENT YUV SMPTE/EBU N-10  
 SLOT NO ..... 6  
 SYNC MODE ..... INT

Select E BOARD DATA LOAD from E BOARD menu of MAINTENANCE menu and execute.

#### • Connection

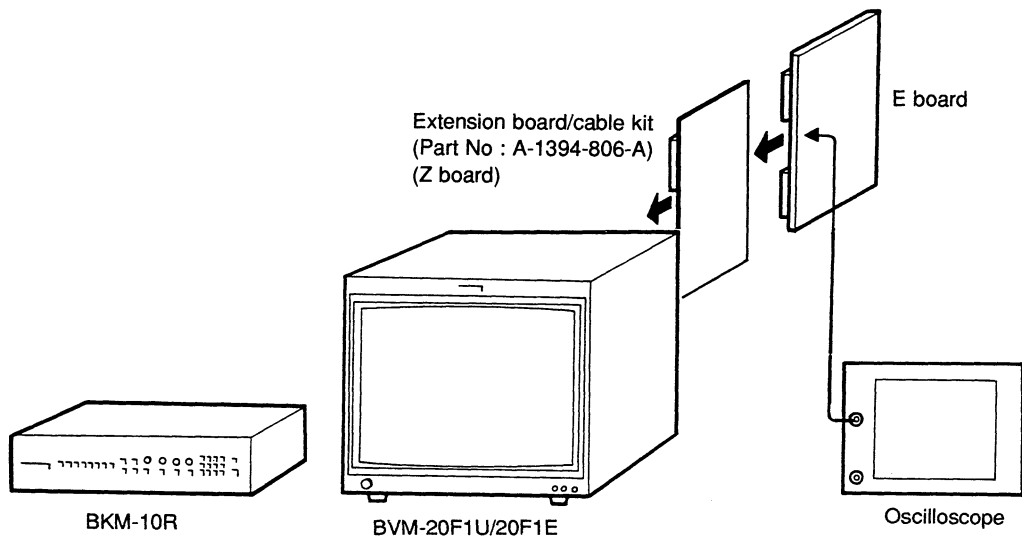


Fig. 1-1.

#### • Arrangement Diagram for Adjustment Parts

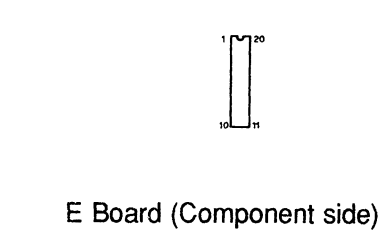


Fig. 1-2.

#### 1-2. V OSC Adjustment

1. Connect an oscilloscope to Pin ⑬ of IC2007 of the E board.
2. Adjust the V OSC data so that the amplitude of the V sawtooth wave becomes  $4.0 \pm 0.2$  Vp-p.

**Note:** The V OSC adjustment menu is under the E BOARD menu of the MAINTENANCE menu.

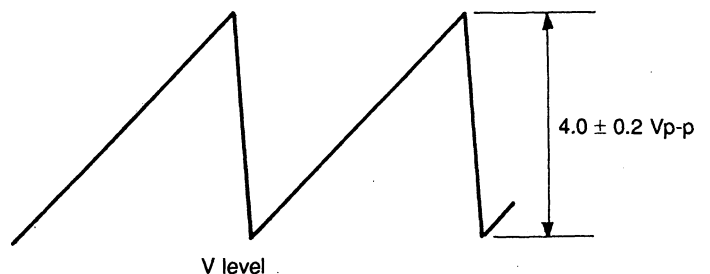


Fig. 1-3.

### 1-3. H OSC Adjustment

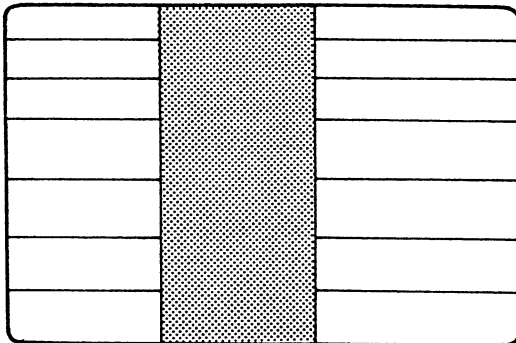
**Note:** The H OSC adjustment menu is under the E BOARD menu of the MAINTENANCE menu.

#### • NTSC H OSC Adjustment

1. Connect the NTSC signal generator, and input the cross hatch signal.
2. Set the SCREEN MODE as follows at the INPUT CONFIGURATION menu of the SETUP menu.  
SCREEN MODE 4 : 3 NORM
3. Set the EXT SYNC mode. (Turn on the SHIFT button (LED lights up in orange) and turn on the SYNC button (LED lights up).)
4. Adjust the H OSC data so that the image becomes still or flows slowly.

#### • PAL H OSC Adjustment

1. Connect the NTSC signal generator, and input the cross hatch signal.
2. Set the SCREEN MODE of the INPUT CONFIGURATION of the SETUP menu as follows.  
SCREEN MODE 4 : 3 NORM
3. Set the EXT SYNC mode. (Turn on the SHIFT button (LED lights up in orange) and turn on the SYNC button (LED lights up).)
4. Adjust the H OSC data so that the image becomes still or flows slowly.



\* Adjust so that the image becomes still or flows slowly.

Fig. 1-4.

### 1-4. H Blanking Adjustment

Refer to 4-1. Basic Adjustment for CRT Replacement [H Blanking Adjustment] (Page 4-3).

### 1-5. V Blanking Adjustment

Refer to 4-1. Basic Adjustment for CRT Replacement [V Blanking Adjustment] (Page 4-5).

### 1-6. Linearity Adjustment

Refer to 4-1. Basic Adjustment for CRT Replacement [Linearity Adjustment] (Page 4-6).

### 1-7. Convergence Adjustment Preparation

Refer to 4-1. Basic Adjustment for CRT Replacement [Focus Adjustment], [Landing Adjustment], [H Blanking Adjustment].

### 1-8. Static Convergence Adjustment

#### • Horizontal Static Convergence

Adjust H STATIC CONV data so that red and green dots match in the horizontal direction at the center of the screen.

**Note :** H STATIC CONV adjustment menu is under E BOARD menu of MAINTENANCE menu. (See Fig. 1-14)

#### • Vertical Static Convergence

Adjust V STATIC CONV data so that red and green dots match in the horizontal direction at the center of the screen.

**Note :** V STATIC CONV adjustment menu is under E BOARD menu of MAINTENANCE menu. (See Fig. 1-14)

### 1-9. Convergence Adjustment 20-Inch Model

#### • Preparation

Refer to 4-1. Basic Adjustment for CRT Replacement [20-Inch Model Convergence Adjustment] (Page 4-8).

#### • Vertical convergence adjustment

Adjust V CONV TOP data and V CONV BOT data so that a vertical mis-convergence is minimized at the top and bottom areas of the screen.

**Note :** V CONV TOP data and V CONV BOT data adjustment menu is under E BOARD menu of MAINTENANCE menu. (See Fig. 1-20)

#### • Horizontal convergence adjustment

Refer to 4-1. Basic Adjustment for CRT Replacement [20-Inch Model Convergence Adjustment] (Page 4-9).

#### • 4 : 3 UNDER SCAN mode convergence adjustment

Refer to 4-1. Basic Adjustment for CRT Replacement [20-Inch Model Convergence Adjustment] (Page 4-9).

#### • 16 : 9 NORMAL SCAN mode convergence adjustment

Refer to 4-1. Basic Adjustment for CRT Replacement [20-Inch Model Convergence Adjustment] (Page 4-9).

#### • 16 : 9 UNDER SCAN mode convergence adjustment

Refer to 4-1. Basic Adjustment for CRT Replacement [20-Inch Model Convergence Adjustment] (Page 4-9).

### 1-10. Convergence Adjustment of 14-inch Model

#### • Preparation

Refer to 4-1. Basic Adjustment for CRT Replacement [14-Inch Model Convergence Adjustment] (Page 4-10).

#### • Convergence adjustment

Adjust V CONV TOP data and V CONV BOT data so that a vertical mis-convergence is minimized at the top and bottom areas of the screen.

**Note :** V CONV TOP data and V CONV BOT data adjustment menu is under E BOARD menu of MAINTENANCE menu. (See Fig. 1-22.)

#### • 4 : 3 UNDER SCAN mode convergence adjustment

Refer to 4-1. Basic Adjustment for CRT Replacement [14-Inch Model Convergence Adjustment] (Page 4-10).

#### • 16 : 9 NORMAL SCAN mode convergence adjustment

Refer to 4-1. Basic Adjustment for CRT Replacement [14-Inch Model Convergence Adjustment] (Page 4-10).

#### • 16 : 9 UNDER SCAN mode convergence adjustment

Refer to 4-1. Basic Adjustment for CRT Replacement [14-Inch Model Convergence Adjustment] (Page 4-10).

## 2. BK Board Adjustment

### 2-1. Adjust Preparation 1

Set as follows at the INPUT CONFIGURATION menu of the SETUP menu.

FORMAT ..... COMPONENT YUV SMPTE/EBU N-10

SLOT NO ..... 6

SYNC MODE ..... INT

Select BK BOARD DATA LOAD from BK BOARD menu of MAINTENANCE menu and execute.

#### • Connection

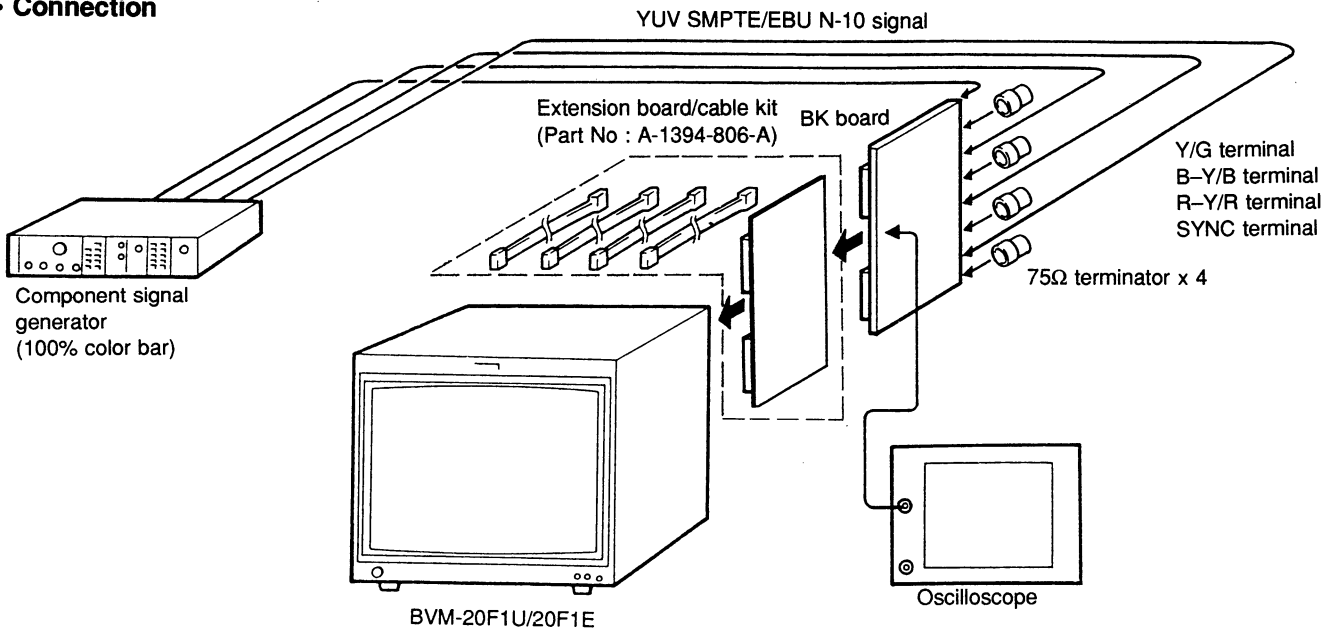


Fig. 2-1.

#### • Arrangement Diagram for Adjustment Parts

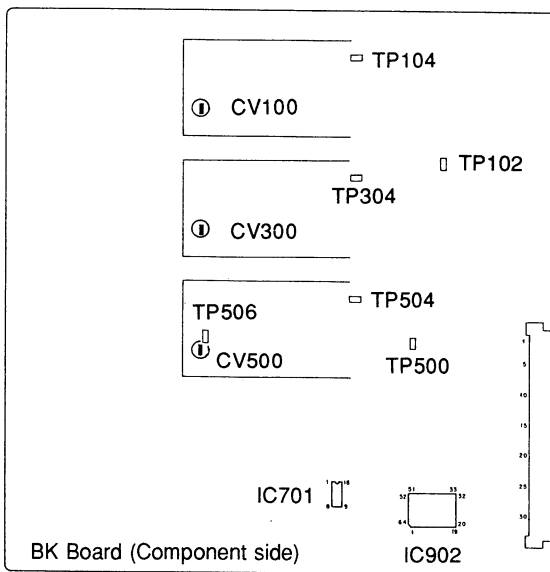


Fig. 2-2.

### 2-2. Bright Center Adjustment

1. Input the component color bar signal (YUV SMPTE/EBU N-10).
2. Set the BRIGHT data to 800 using the BRIGHT knob.
3. Connect an oscilloscope to Pin ⑮ of IC701 of the BK board.
4. As shown in Fig. 2-3, adjust the BRT CENTER data so that the waveform becomes flat.

**Note:** The BRT CENTER adjustment menu is under the BK BOARD menu of the MAINTENANCE menu.

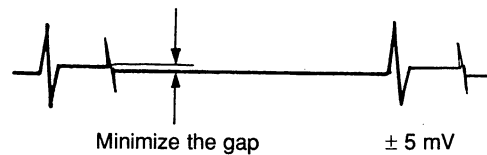


Fig. 2-3.

### 2-3. Clamp Level Adjustment

**Note:** The following adjustment menus are under the BK BOARD menu of the MAINTENANCE menu.

- R-Y CLAMP OFFSET
- B-Y CLAMP OFFSET

1. Input the component color bar signal (YUV SMPTE/EBU-N10).
2. Connect the oscilloscope to TP102.
3. As shown in Fig. 2-4, adjust the R-Y CLAMP OFFSET data so that the pedestal and clamp offset pulse level becomes equal.
4. Connect the oscilloscope to TP502.
5. As shown in Fig. 2-5, adjust the B-Y CLAMP OFFSET data so that the pedestal and clamp offset pulse level becomes equal.

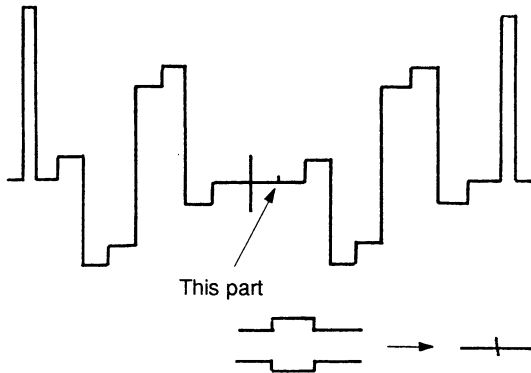


Fig. 2-4.

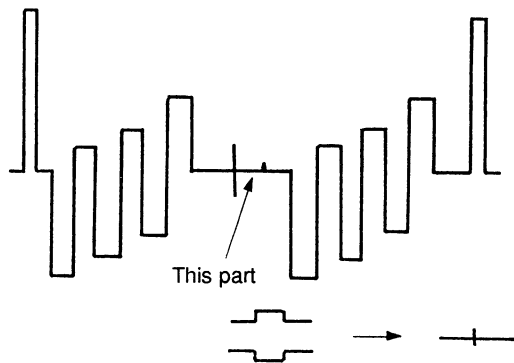


Fig. 2-5.

### 2-4. Adjustment Preparations 2

Perform the following adjustments for each of the following five input signals.

Set the settings required for each signal at the INPUT CONFIGURATION of the SETUP menu. When inputting the composite signal, insert the NTSC input adapter BKM-24N into the empty slot of the unit.

1. COMPONENT SMPTE/EBU-N10
  - 100% color bar signal
    - All white peak 700 mV
    - B-Y 700 mVp-p
    - R-Y 700 mVp-p
  - 100 IRE all white signal
    - All white peak 700 mV
  - 20 IRE all white signal
    - All white peak 140 mV
2. COMPONENT BETACAM SETUP 7.5
  - 75% color bar signal
    - All white peak 714.29 mV
    - B-Y 700 mVp-p
    - R-Y 700 mVp-p
  - 100 IRE all white signal
    - All white peak 714.29 mV
  - 20 IRE all white signal
    - All white peak 142.86 mV
3. COMPOSITE NTSC SETUP 7.5
  - 100% color bar signal
    - All white peak 714 mV
4. COMPOSITE NTSC SETUP 0
  - 75% color bar signal
    - All white peak 714 mV
5. COMPOSITE NTSC SETUP 0
  - 100% color bar signal
    - All white peak 714 mV

Set as follows at the INPUT CONFIGURATION menu of the SETUP menu.

- FORMAT .....Set according to the input signal
- SLOT NO .....When component signal is input : 6  
When composite signal is input : Slot no.  
when BKM-24N is mounted.
- SYNC MODE .....INT

### Configuration when Component Signal is Input

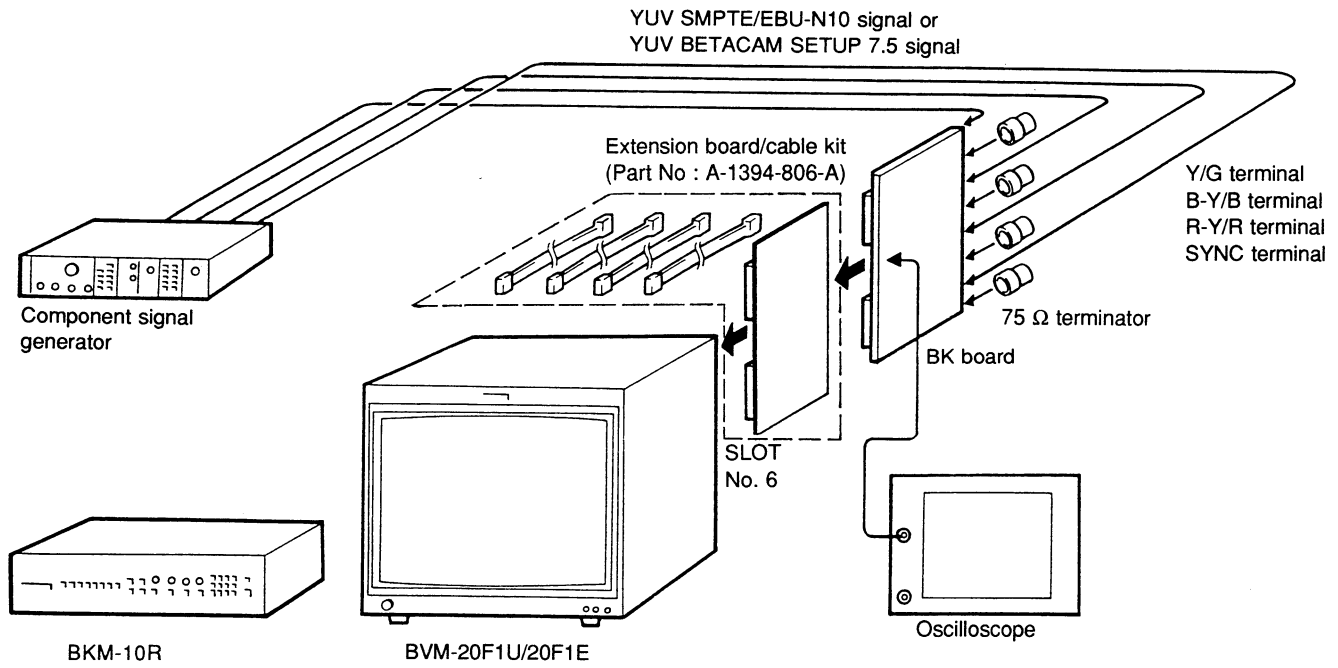


Fig. 2-6.

### Configuration when Composite Signal is Input

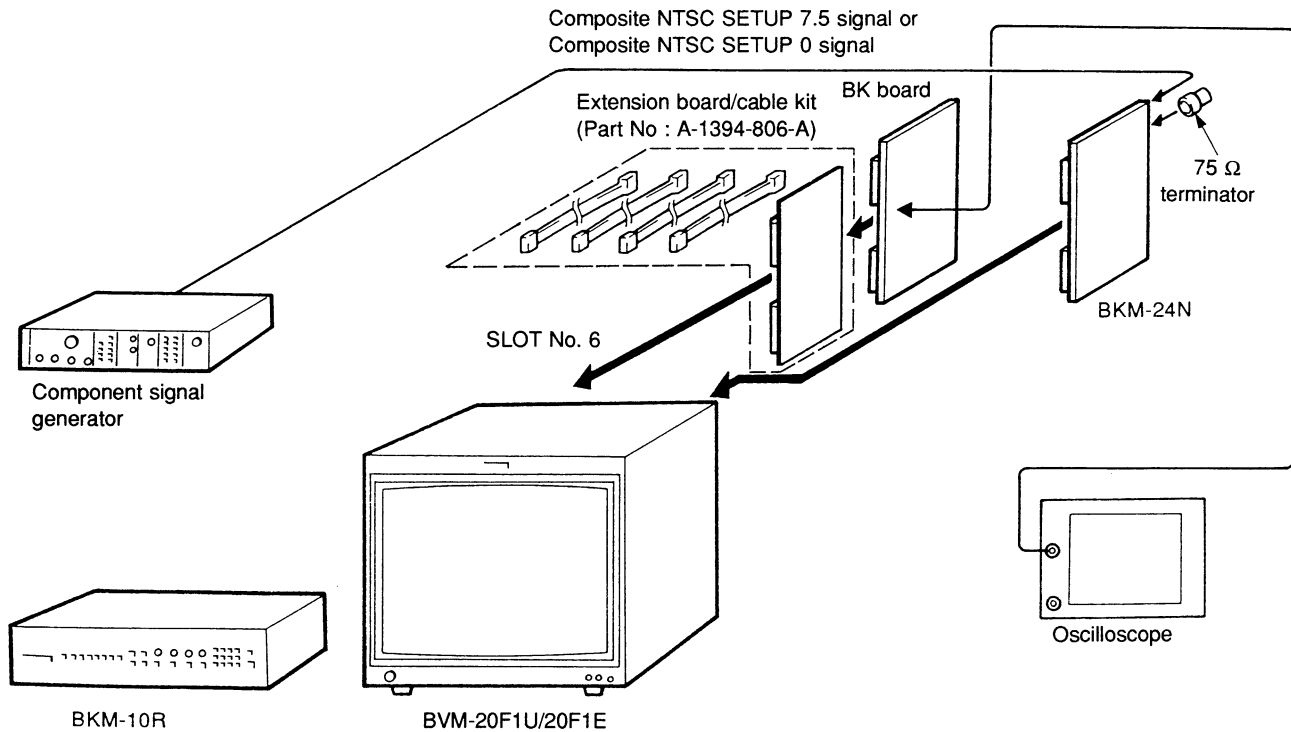


Fig. 2-7.



## 2-5. Pulse Level Adjustment

**Note:** The following adjustment menus are under the BK BOARD menu of the MAINTENANCE menu.

B-Y PULSE LEVEL  
R-Y PULSE LEVEL

1. Input the color bar signal.
2. Set the CHROMA data to 500 using the CHROMA knob.
3. Connect the oscilloscope to TP504.
4. As shown in Fig. 2-8, adjust the B-Y PULSE LEVEL data so that the BLUE waveform becomes flat.

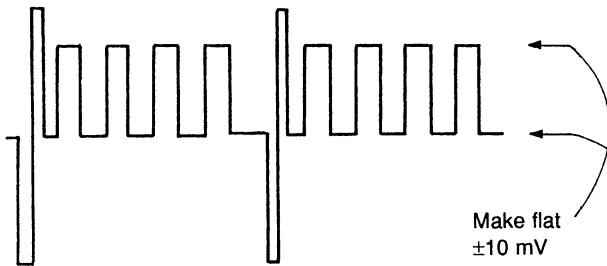


Fig. 2-8.

5. Connect the oscilloscope to TP104.
6. As shown in Fig. 2-9, adjust the R-Y PULSE LEVEL data so that the RED waveform becomes flat.

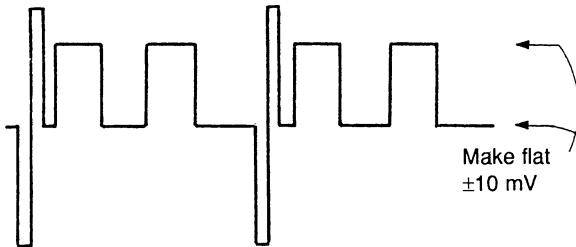


Fig. 2-9.

## 2-6. R-Y Gain, B-Y Gain Adjustment

**Note:** The following adjustment menus are under the BK BOARD menu of the MAINTENANCE menu.

B-Y GAIN  
R-Y GAIN

1. Input the color bar signal.
2. Set the CHROMA data to 500 using the CHROMA knob.
3. Connect the oscilloscope to TP304.
4. As shown in Fig. 2-10, adjust the R-Y GAIN data and B-Y GAIN data so that the GREEN waveform becomes flat.

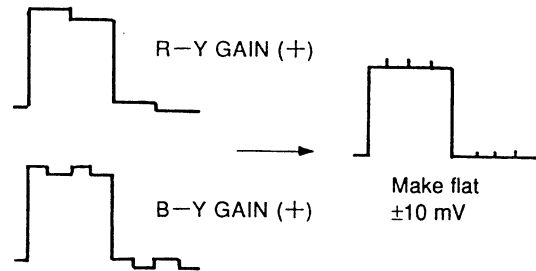


Fig. 2-10.

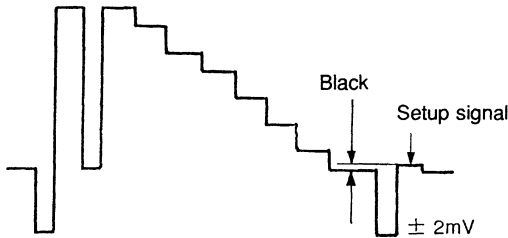
## 2-7. 0% Setup Adjustment

**Note:**The following adjustment menus are under the BK BOARD menu of the MAINTENANCE menu.

R SETUP  
G SETUP  
B SETUP

1. Input only the Y signal of the color bar signal (Turn off the R-Y signal and B-Y signal).
2. Connect the oscilloscope to TP104.
3. As shown in Fig. 2-11, adjust the R SETUP data so that the black level and setup signal level becomes equal.
4. Connect the oscilloscope to TB304.
5. As shown in Fig. 2-11, adjust the G SETUP data so that the black signal level and setup signal level become equal.
6. Connect the oscilloscope to TP504.
7. As shown in Fig. 2-11, adjust the B SETUP data so that the black signal level and setup signal level become equal.

When SETUP 0% signal is input



When SETUP 7.5% signal is input

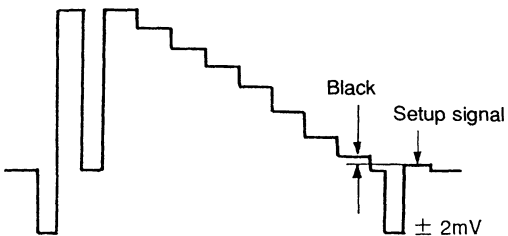


Fig. 2-11.

## 2-8. 100 IRE Adjustment

**Note:**The following adjustment menus are under the BK BOARD menu of the MAINTENANCE menu.

R 100 IRE  
G 100 IRE  
B 100 IRE

1. Input only the Y signal of the color bar signal (Turn off the R-Y signal and B-Y signal).
2. Connect the oscilloscope to TP104.
3. As shown in Fig. 2-12, adjust the R 100 IRE data so that the 100 IRE level and 100 IRE pulse level of the signal become equal.
4. Connect the oscilloscope to TB304.
5. As shown in Fig. 2-12, adjust the G 100 IRE data so that the 100 IRE level and 100 IRE pulse level of the signal become equal.
6. Connect the oscilloscope to TB504.
7. As shown in Fig. 2-12, adjust the B 100 IRE data so that the 100 IRE level and 100 IRE pulse level of the signal become equal.

Minimize the level difference.  $\pm 2$  mV

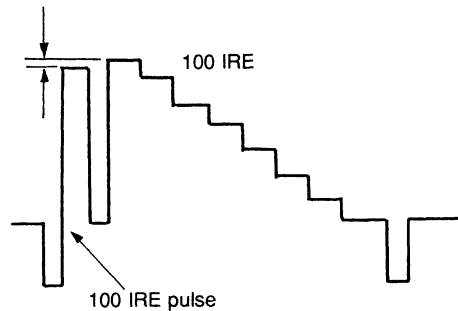


Fig. 2-12.

## 2-9. BIAS REF Adjustment

**Note:**The following adjustment menu is under the BK BOARD menu of the MAINTENANCE menu.

BIAS REF

1. Input the 20 IRE all-white signal.
2. Connect the oscilloscope to TP506.
3. As shown in Fig. 2-13, adjust the BIAS REF data so that the all white peak level and BIAS REF pulse level of the signal become equal.

(Oscilloscope is V period)

Minimize the level difference.  $\pm 5$  mV

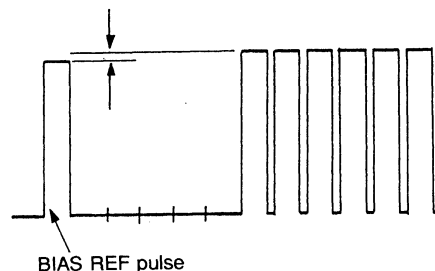


Fig. 2-13.

## 2-10. DRIVE REF Adjustment

**Note:** The following adjustment menu is under the BK BOARD menu of the MAINTENANCE menu.  
DRIVE REF

1. Input the 100 IRE all-white signal.
2. Connect the oscilloscope to TP506.
3. As shown in Fig. 2-14, adjust the DRIVE REF data so that the all white peak level and DRIVE REF pulse level of the signal become equal.

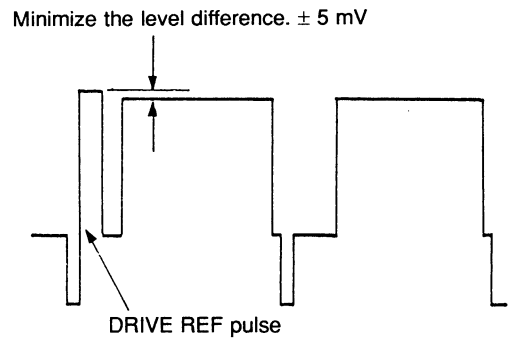


Fig. 2-14.

## 2-11. Adjustment Preparation 3

Perform the following adjustments using the RGB input signals. Set as follows at the INPUT CONFIGURATION menu of the SETUP menu.

FORMAT ..... COMPONENT RGB  
SLOT NO ..... 6  
SYNC MODE ..... INT

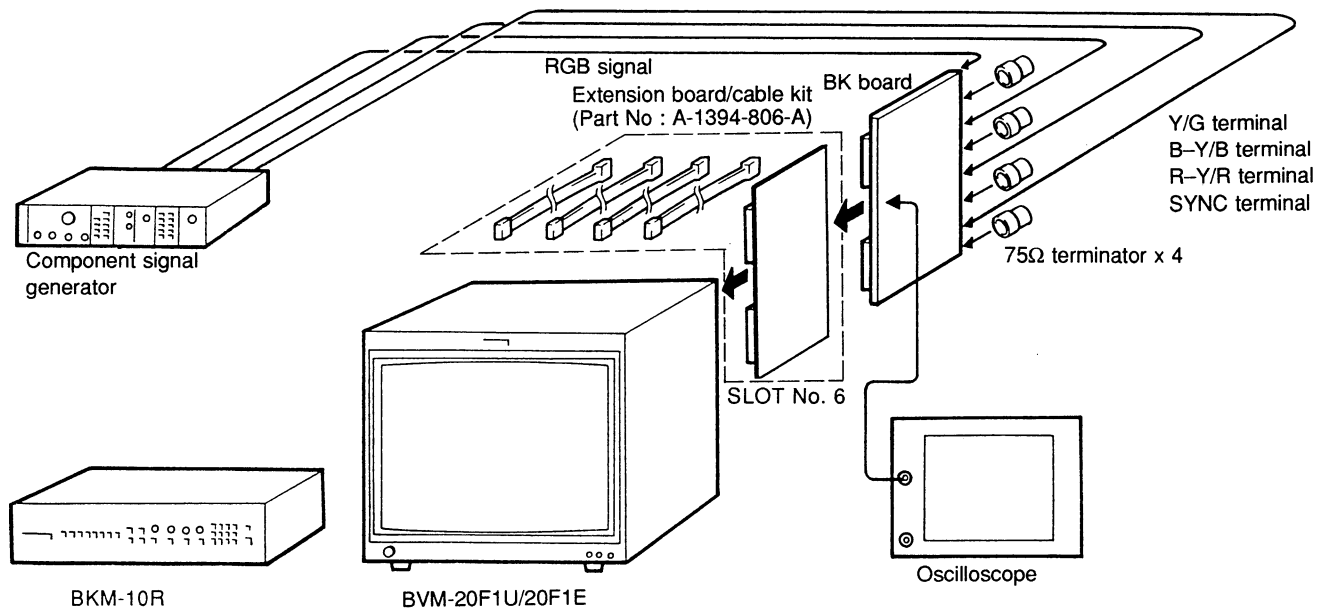


Fig. 2-15.

## 2-12. RGB Signal SETUP Adjustment

**Note:**The following adjustment menus are under the BK BOARD menu of the MAINTENANCE menu.

R SETUP  
G SETUP  
B SETUP

1. Input 100 IRE RGB signal.
2. Connect the oscilloscope to TP104.
3. Adjust the R SETUP data so that the black level and setup signal level become equal.
4. Connect the oscilloscope to TP304.
5. Adjust the G SETUP data so that the black signal level and setup signal level become equal.
6. Connect the oscilloscope to TP504.
7. Adjust the B SETUP data so that the black signal level and setup signal level become equal.

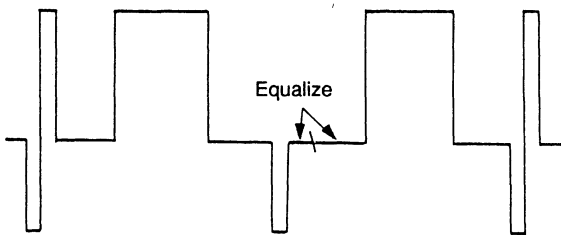


Fig. 2-16.

## 2-13. RGB Signal 100 IRE Adjustment

**Note:**The following adjustment menus are under the BK BOARD menu of the MAINTENANCE menu.

R 100 IRE  
G 100 IRE  
B 100 IRE

1. Input the 100 IRE RGB signal.
2. Connect the oscilloscope to TP104.
3. Adjust the R 100 IRE data so that the 100 IRE level and 100 IRE pulse level of the signal become equal.
4. Connect the oscilloscope to TP304.
5. Adjust the G 100 IRE data so that the 100 IRE level and 100 IRE pulse level of the signal become equal.
6. Connect the oscilloscope to TP504.
7. Adjust the B 100 IRE data so that the 100 IRE level and 100 IRE pulse level of the signal become equal.

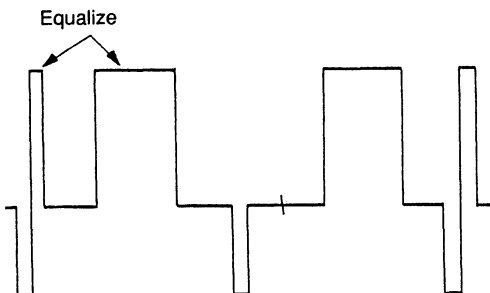


Fig. 2-17.

## 2-14. Characteristics Adjustment

1. Input the 0 to 10 MHz sweep signal to the R-Y/R terminal.
2. Connect the oscilloscope to TP2 (RK) of the C board.
3. Adjust CV100 of the BK board so that the 0 to 10 MHz range of the waveform becomes flat.
4. Input the 0 to 10 MHz sweep signal to the Y/G terminal.
5. Connect TP3 (GK) of the C board to the oscilloscope.
6. Adjust CV300 of the BK board so that the 0 to 10 MHz range of the waveform becomes flat.
7. Input the 0 to 10 MHz sweep signal to the B-Y/B terminal.
8. Connect TP4 (BK) of the C board to the oscilloscope.
9. Adjust CV500 of the BK board so that the 0 to 10 MHz range of the waveform becomes flat.

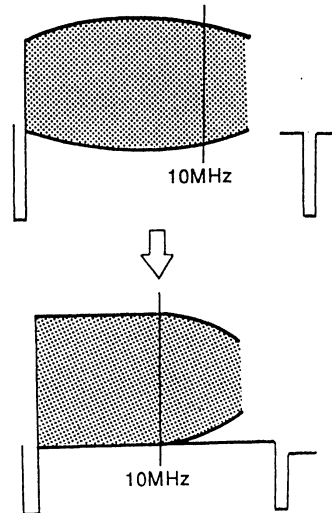


Fig. 2-18.

## 2-15. White Balance Adjustment

Refer to 4-1. Basic Adjustment for CRT Replacement [White Balance Adjustment] (Page 4-11).

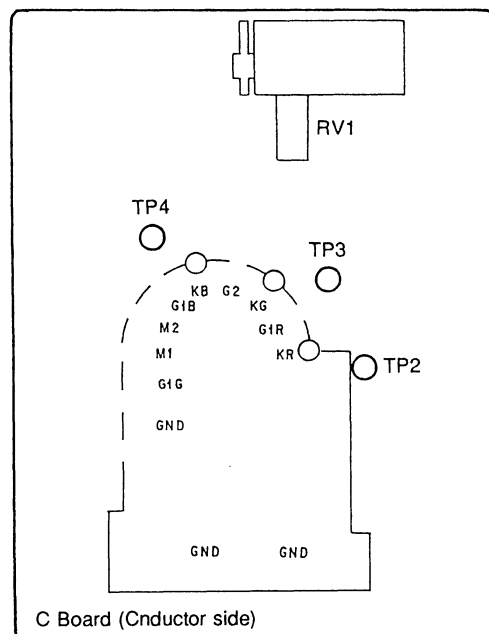


Fig. 2-19.

### 3. BC Board Adjustment

#### 3-1. Adjust Preparation

Set 1CH as follows using INPUT CONFIGURATION menu of SETUP menu.

FORMAT ..... COMPONENT YUV SMPTE/EBU N-10  
 SLOT NO ..... 6  
 SYNC MODE ..... INT

#### • Connection

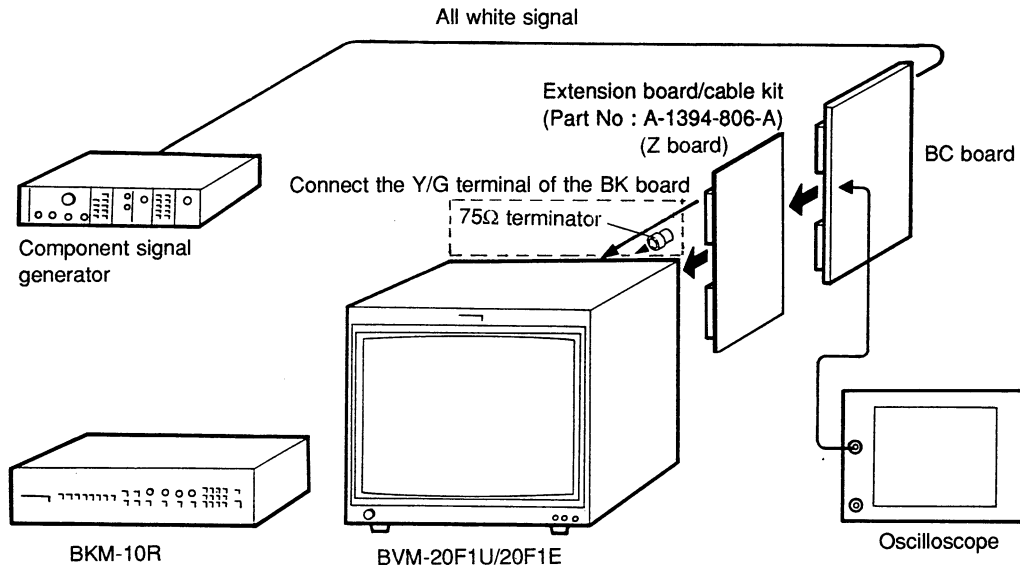


Fig. 3-1.

#### • Arrangement Diagram for Adjustment Parts

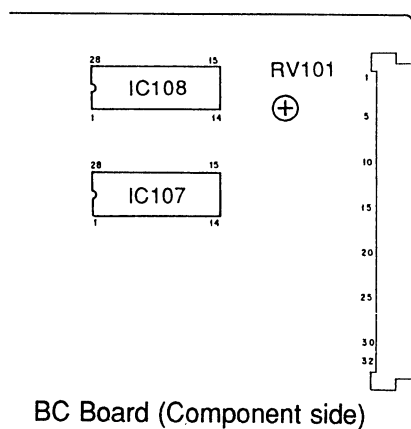


Fig. 3-2.

#### 3-2. Built-in Signal Level Adjustment

1. Input the all-white signal to the Y/G terminal of the BK board.
2. Connect the oscilloscope to Pin (B10) of CN1 of the BC board.
3. Select 1CH and measure and all-white signal level of Y/G terminal input signal.
4. Select 93CH and select an internal white signal.
5. Adjust RV101 of the BC board so that the internal white signal level becomes the same as (measured level in step 3.) the all-white signal of the Y/G terminal input.

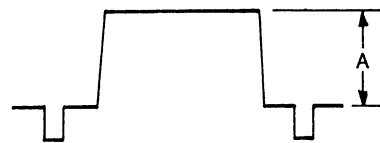


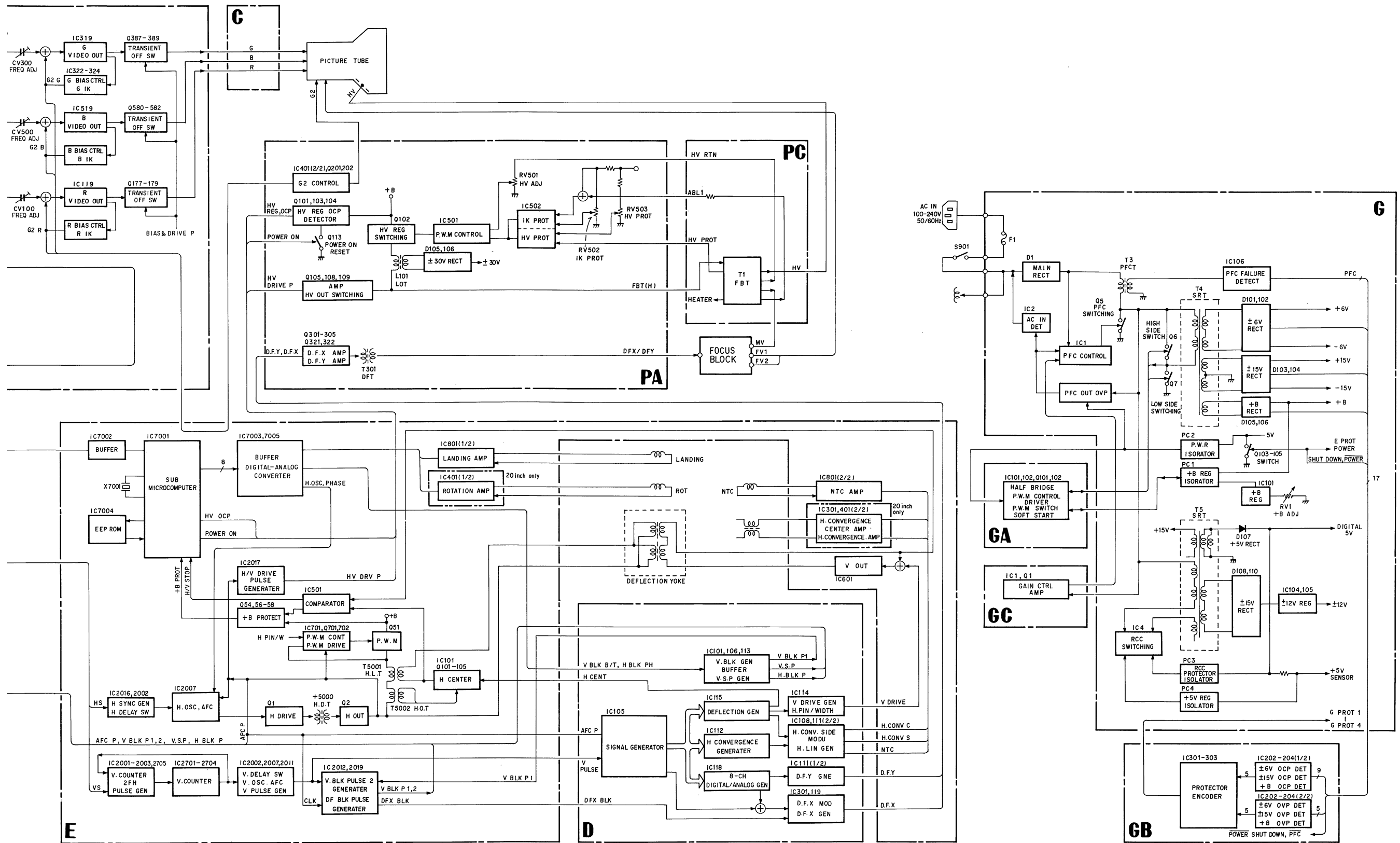
Fig. 3-3.



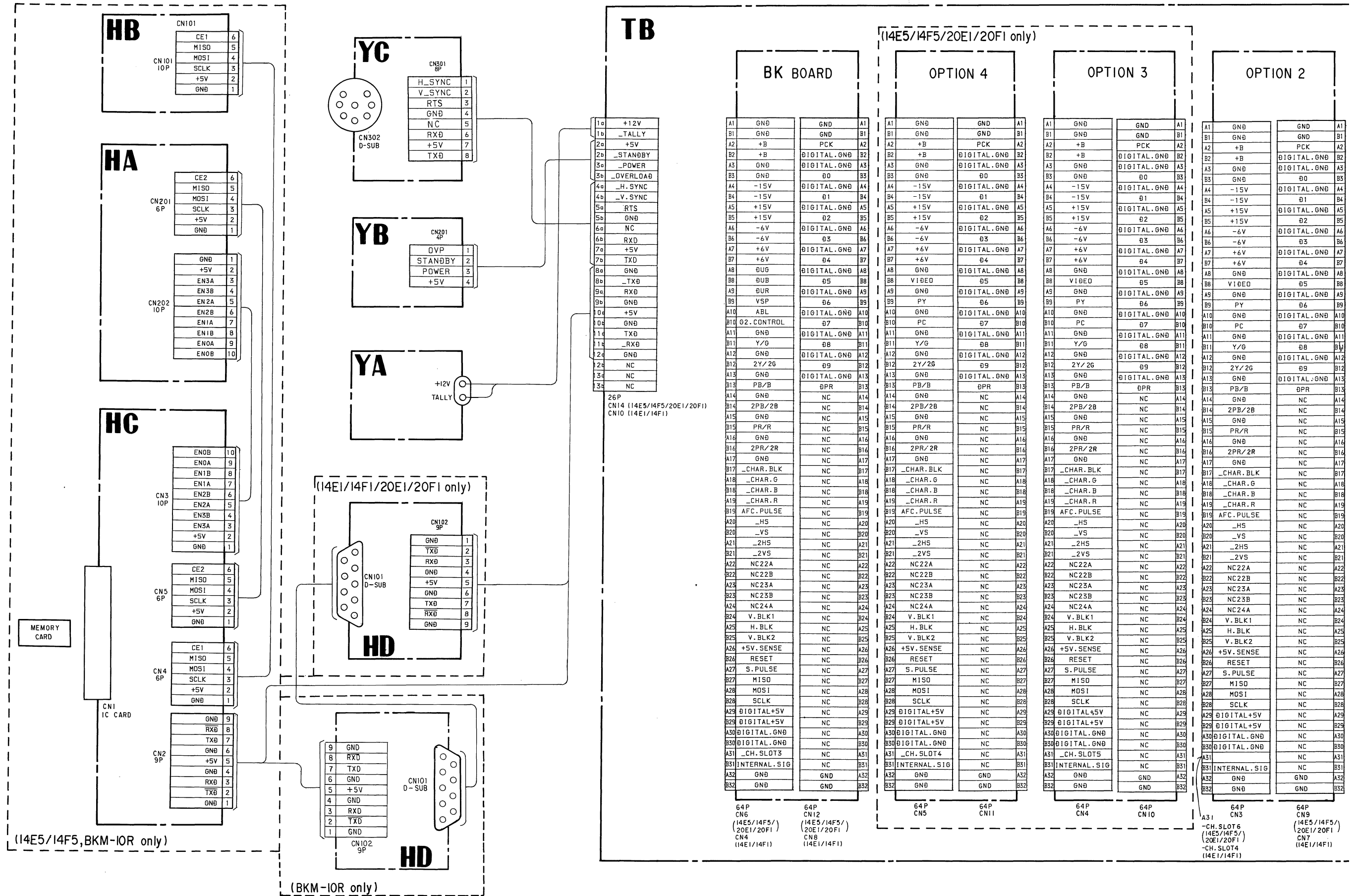
**SECTION 5  
DIAGRAMS**

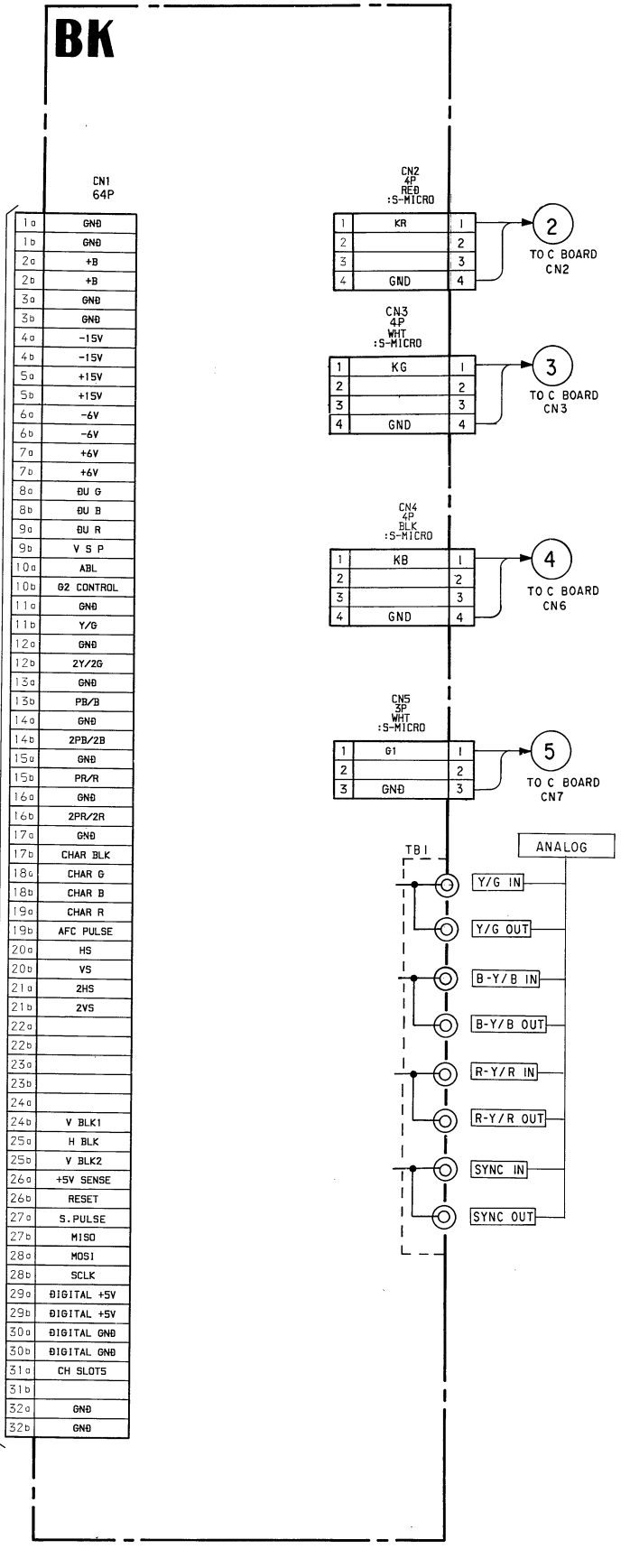
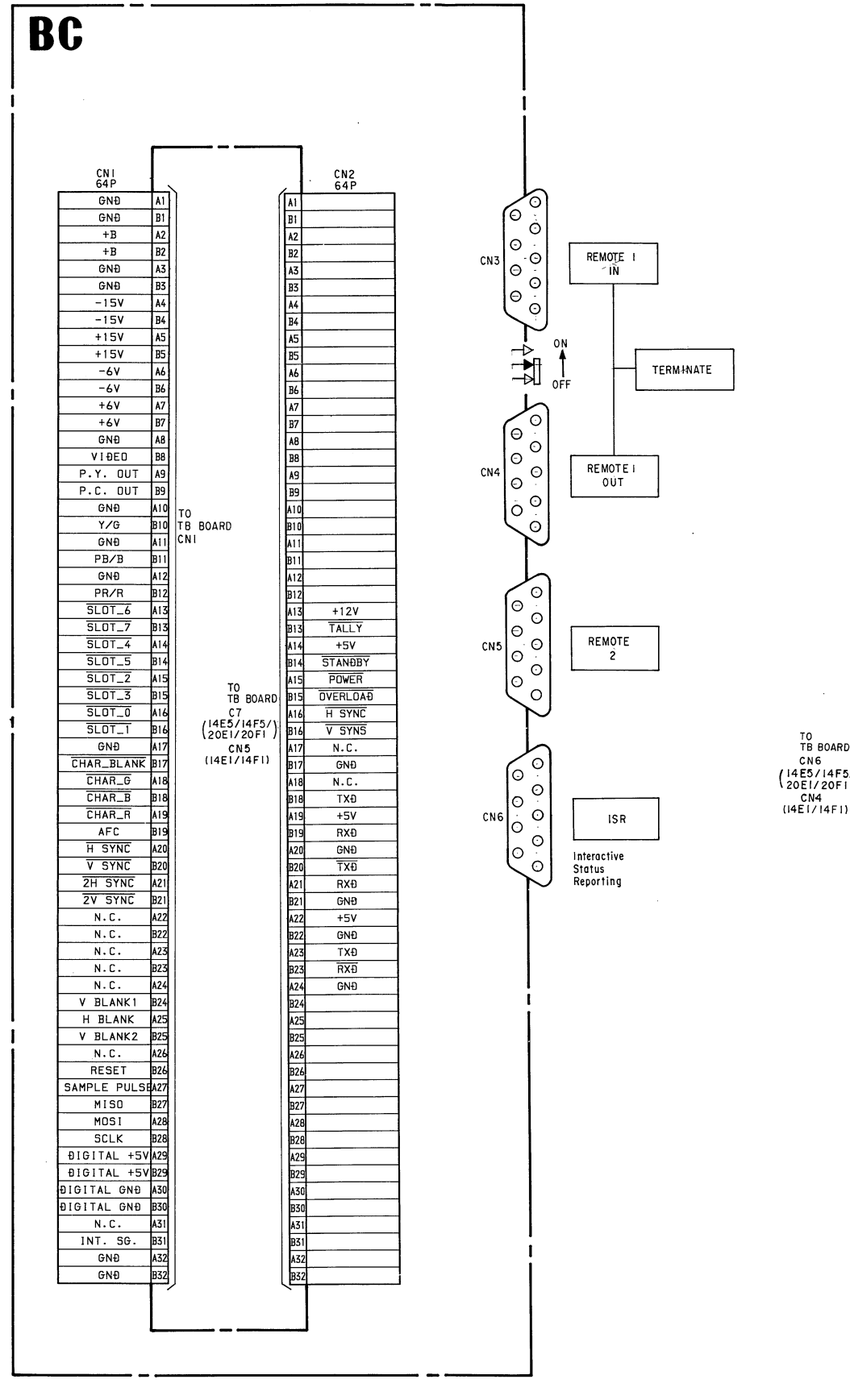
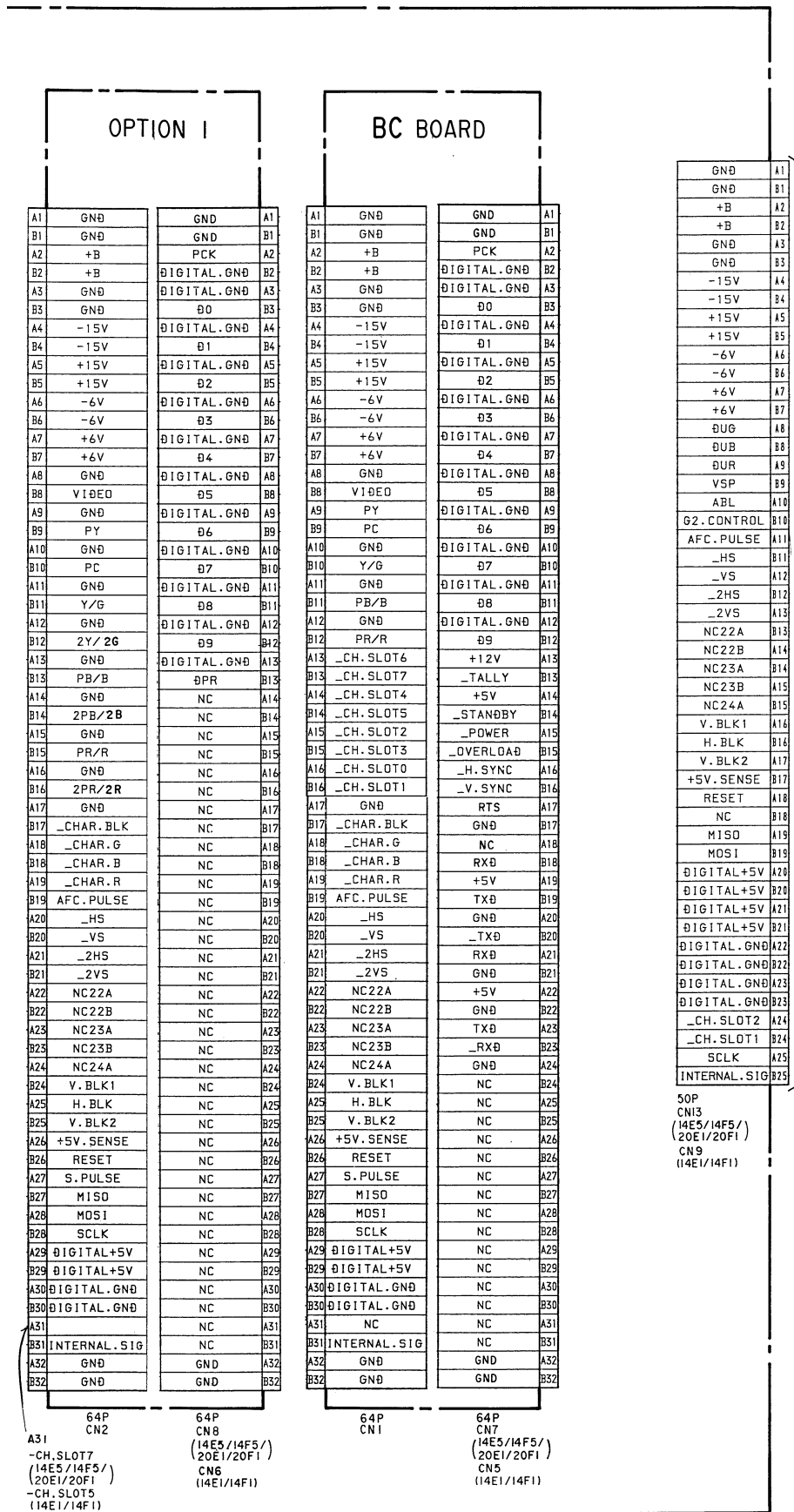






5-2. FRAME SCHEMATIC DIAGRAM (1)





FRAME SCHEMATIC DIAGRAM (2)

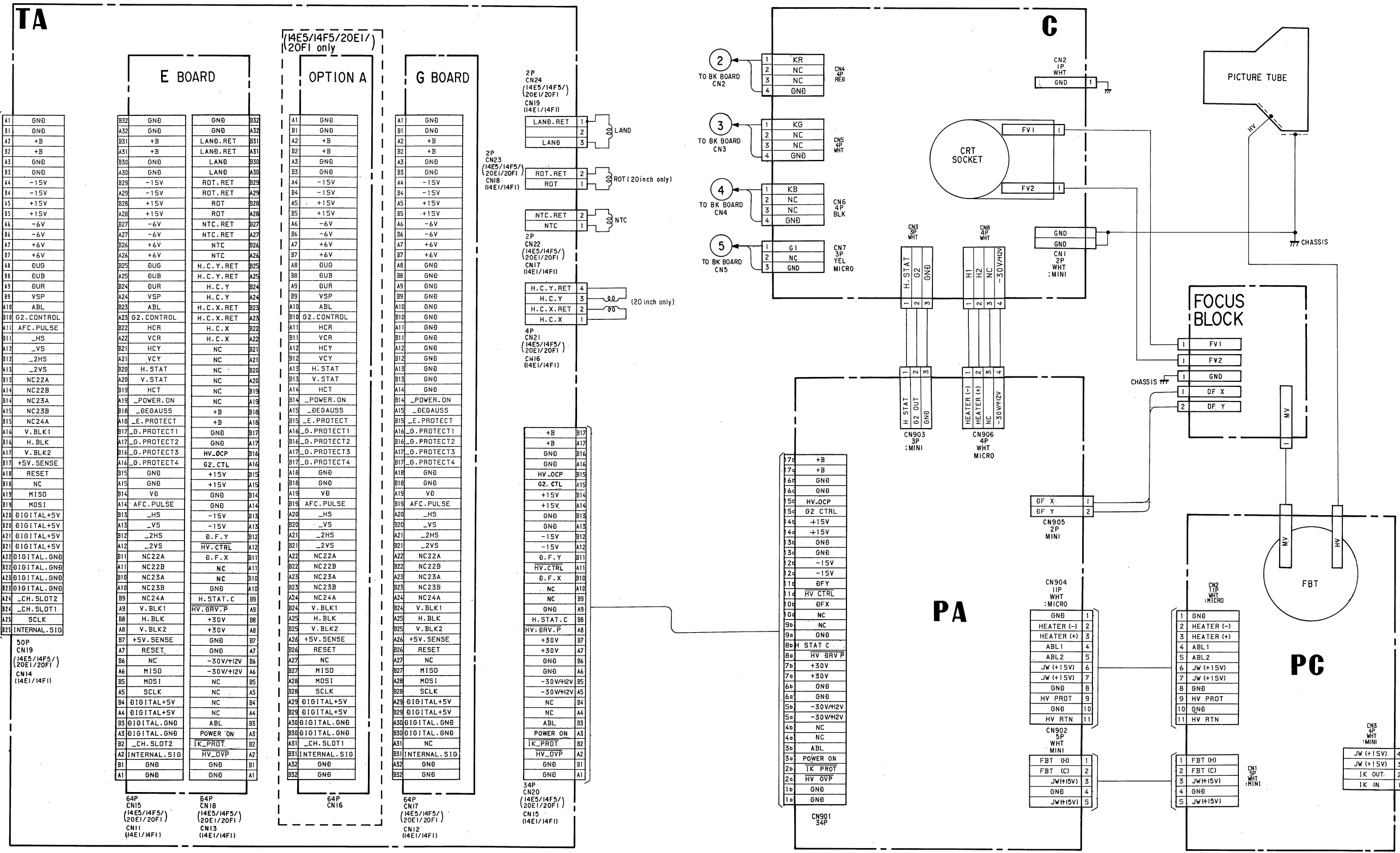
1

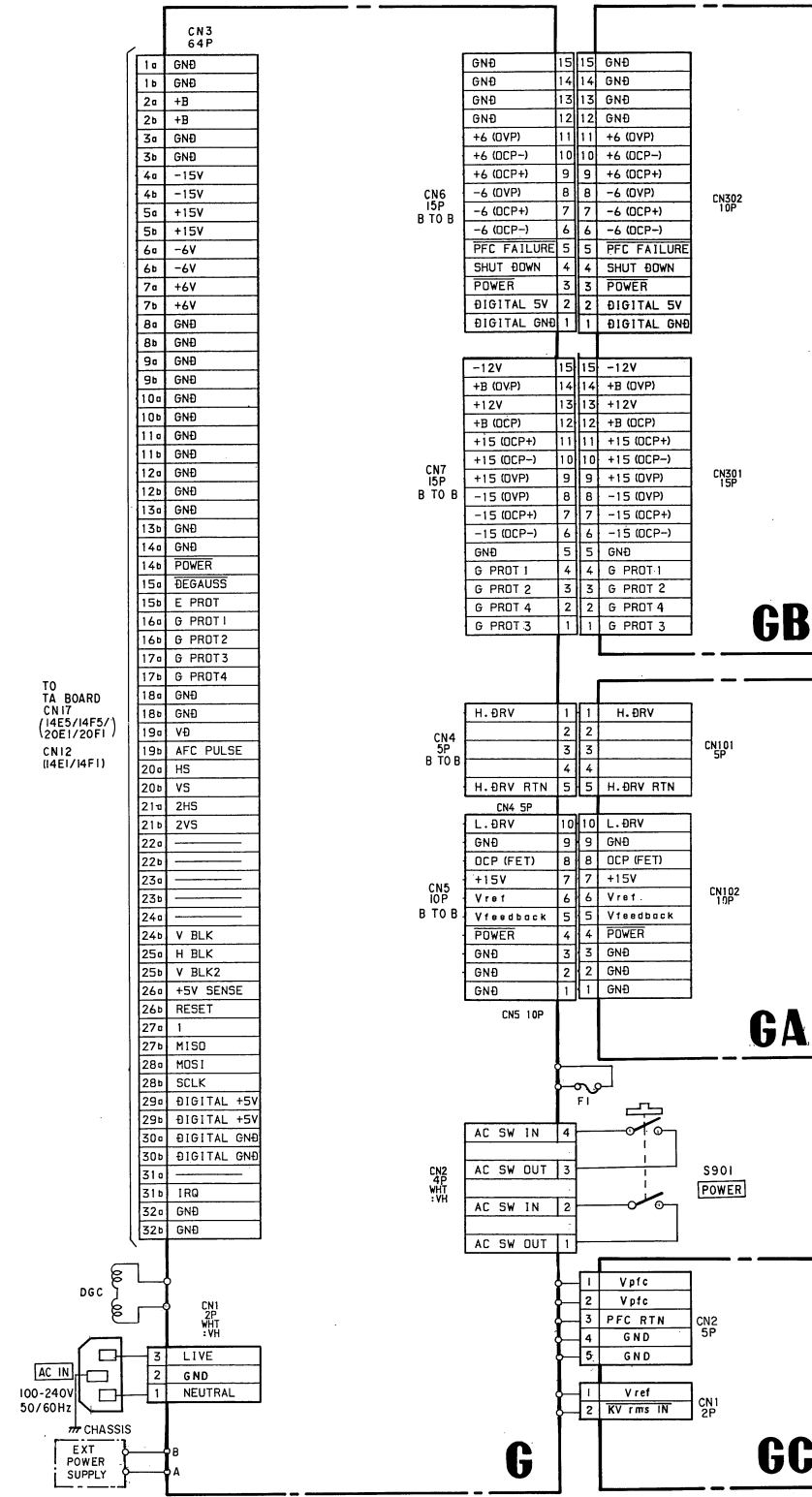
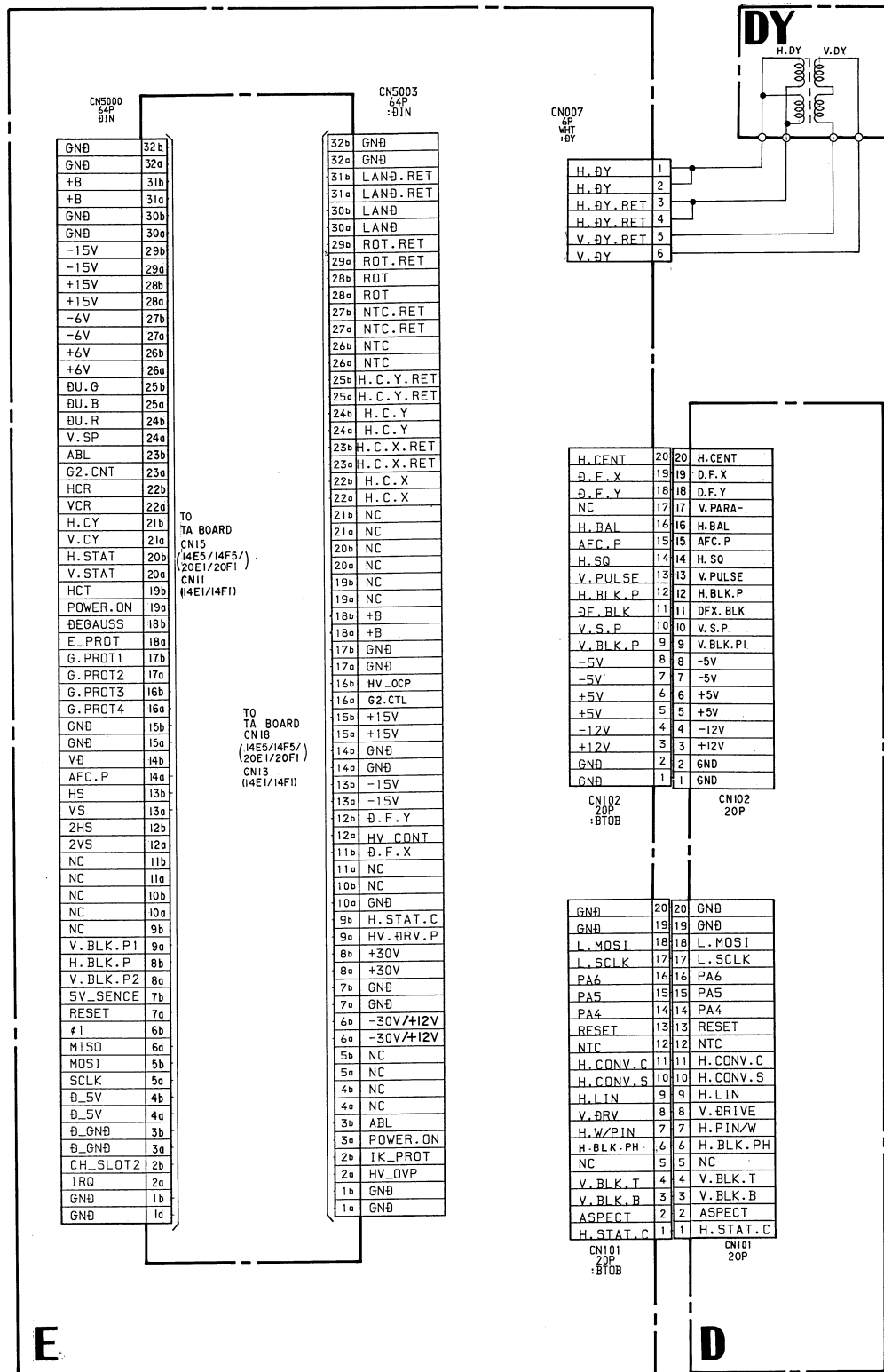
2

3

4

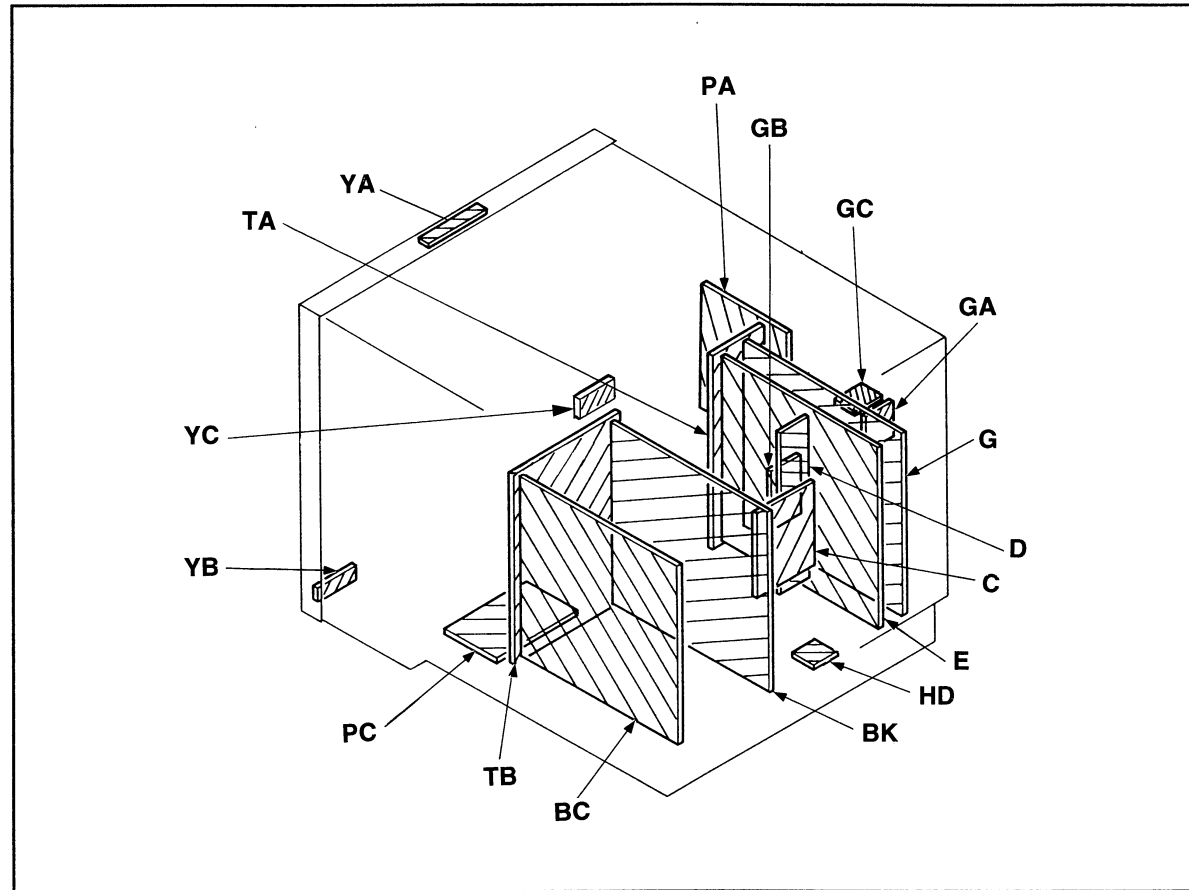
5



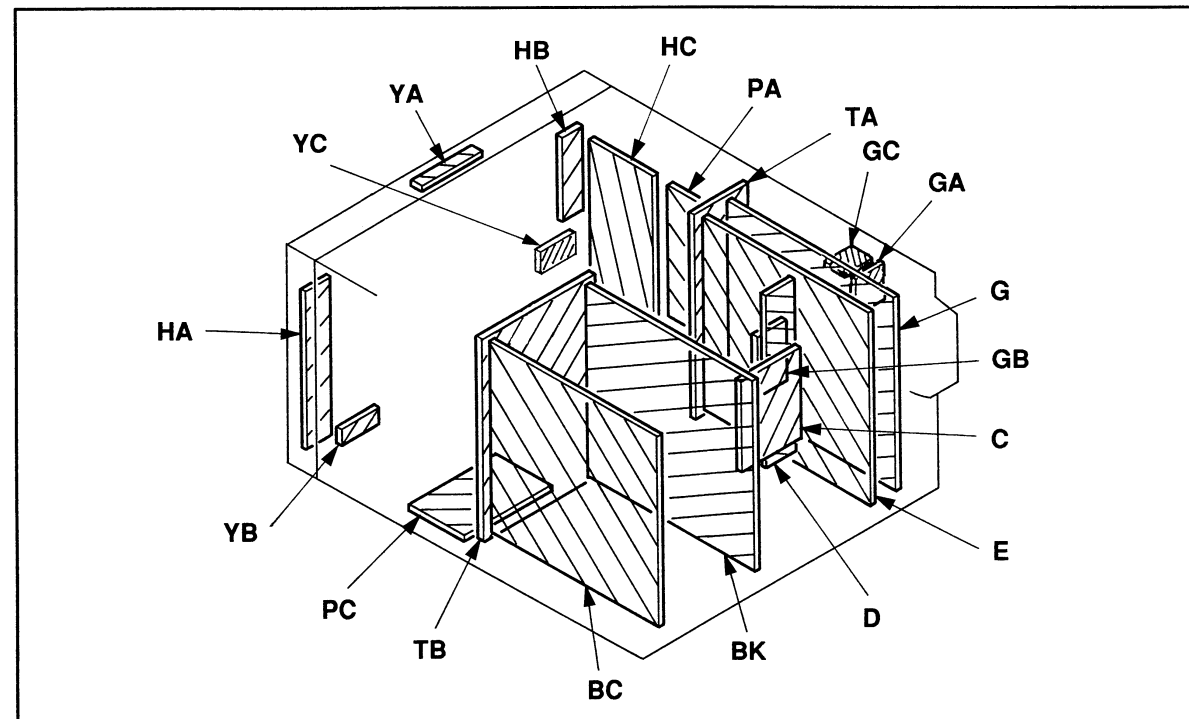


### 5-3. CIRCUIT BOARDS LOCATION

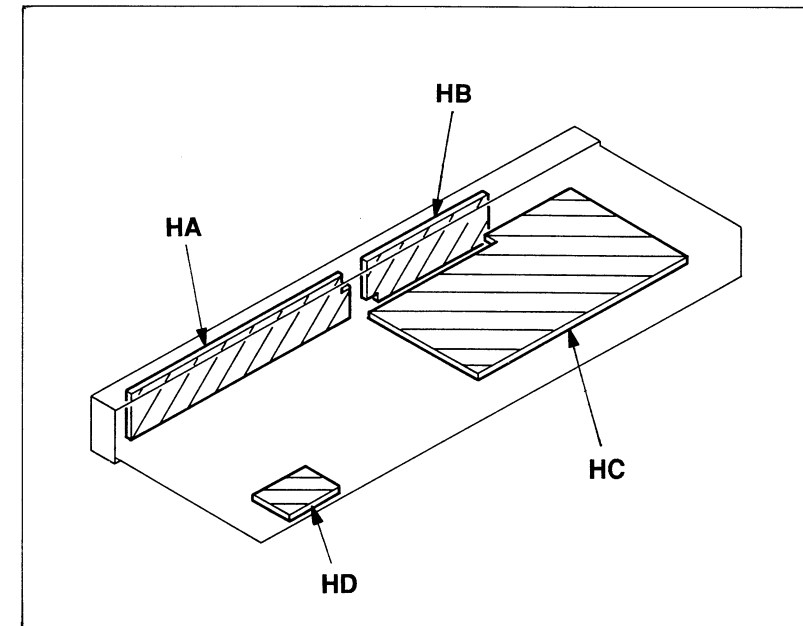
BVM-14E1E/14E1U/14F1E/14F1U/20E1E/20E1U/20F1E/20F1U



BVM-14E5E/14E5U/14F5E/14F5U



BKM-10R



### 5-4. PRINTED WIRING BOARDS AND SCHEMATIC DIAGRAMS

**Note:**

- All capacitors are in  $\mu\text{F}$  unless otherwise noted.
- pF:  $\mu\text{F}$  50WV or less are not indicated except for electrolytics.
- Indication of resistance, which does not have one for rating electrical power, is as follows.

Pitch: 5 mm  
Rating electrical power 1/4W

- All resistors are in ohms.
- : nonflammable resistor.
- Chip resistor are 1/10W unless otherwise noted.
- : fusible resistor.
- : internal component.
- : panel designation.
- All variable and adjustable resistors have characteristic curve B, unless otherwise noted.
- METAL FILM (: RN) resistor in 0.5%, 1/4W unless otherwise specified.
- The components identified by in this basic schematic diagram have been carefully factory-selected for each set in order to satisfy regulations regarding X-ray radiation. Should replacement be required, replace only with the value originally used.
- When replacing components identified by , make the necessary adjustments indicated. If results do not meet the specified value, change the component identified by and repeat the adjustment until the specified value is achieved. (Refer to RV101, RV501, RV502 and RV503 on page 4-12 to 4-15.)

Part replaced (▣)	Adjustment (▣)
IC101, PC1, R115, R116, R119, R120, R121, R122, RV101 ..... G board IC102, R111 ..... GA board	RV101 (+B VOLTAGE)
IC501, R509, R510, R513, R801, R802, R804, RV501 ..... PA board	RV501 (HIGH VOLTAGE)
IC502, R101, R514, R515, R516, R517, RV502 ..... PA board R1, R2, R3, R4, R5, R6 ..... PC board IC901, R912, R913 ..... BK board	RV502 (BEAM CURRENT)
IC502, R524, R525, R526, R527, R530, R808, RV503.. PA board	RV503 (HOLD-DOWN)

- : Adjustment for repair.
- All voltages are in V.
- Reading are taken with component color-bar signal (R.G.B SYNC) input.
- Voltage are dc with respect to ground unless otherwise noted.
- no mark : 14inch model and comon  
( ) : 20 inch model
- Voltage variations may be noted due to normal production tolerance.
- : B+ line.
- : B- line.
- : signal path.
- Circled numbers are waveforms reference.

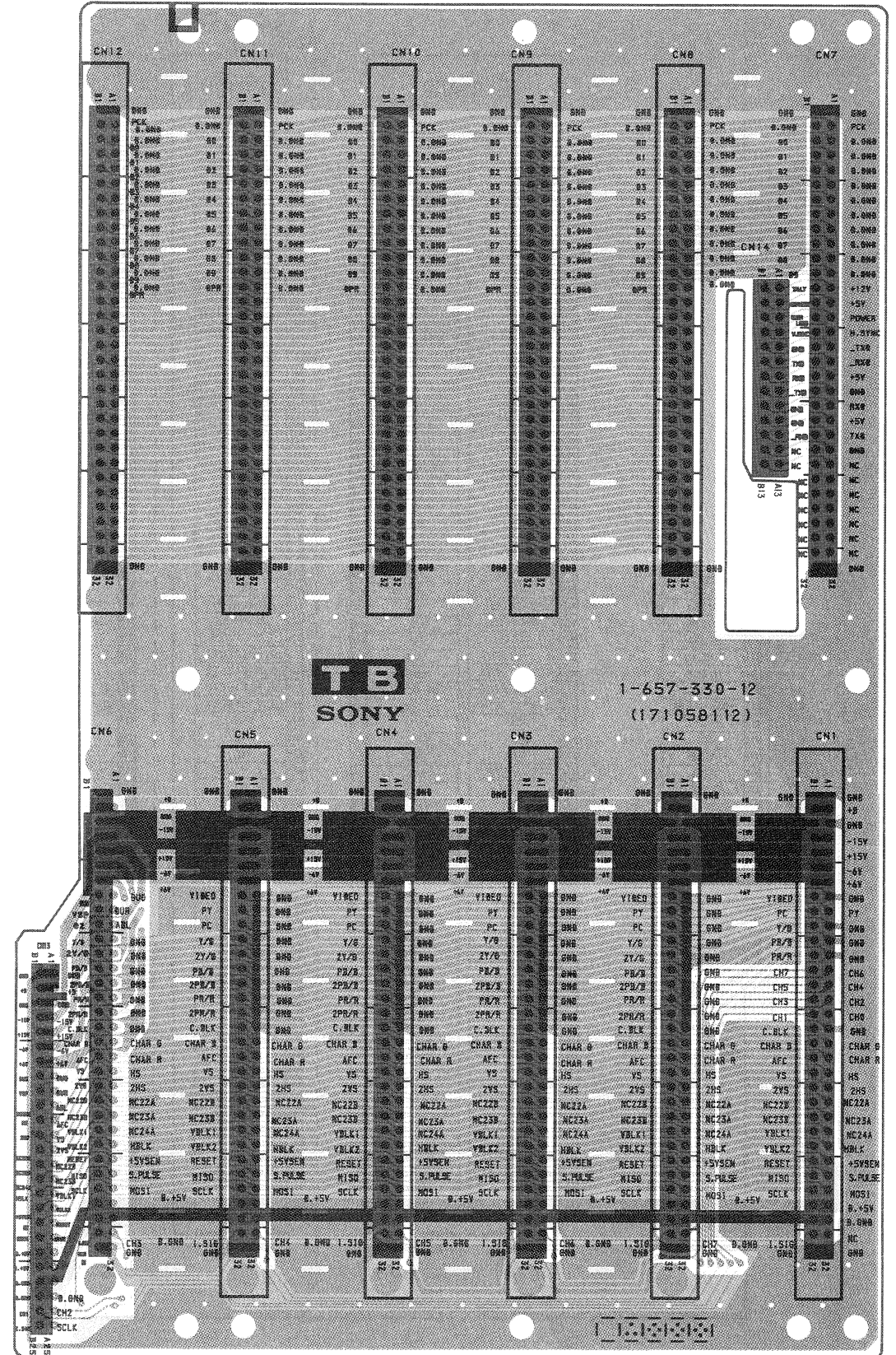
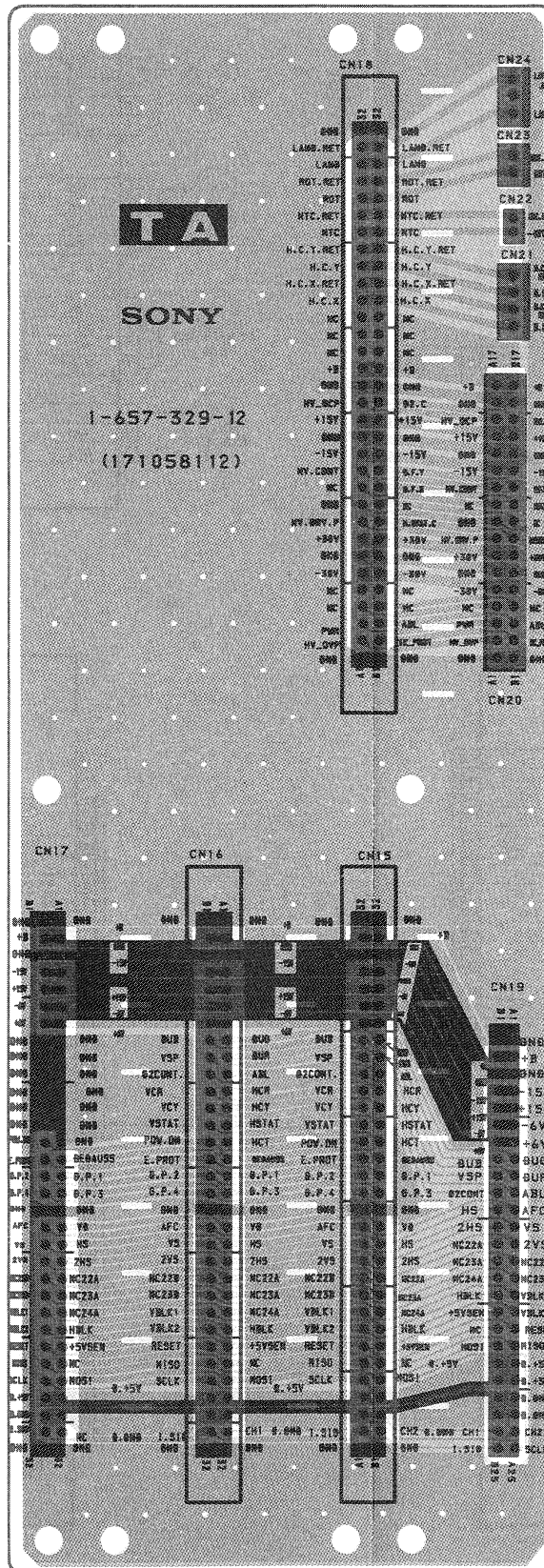


**TA** (MOTHER)  
(BVM-14E5E/14E5U/14F5E/14F5U/20E1E/20E1U/20F1E/20F1U)

**TB** (MOTHER) (BVM-14E5E/14E5U/14F5E/14F5U/20E1E/20E1U/20F1E/20F1U)

— TA BOARD — <Conductor Side>

— TB BOARD — <Conductor Side>



**Reference information**

- |           |         |                          |
|-----------|---------|--------------------------|
| RESISTOR  | : RN    | METAL FILM               |
|           | : RC    | SOLID                    |
|           | : FPRD  | NONFLAMMABLE CARBON      |
|           | : FUSE  | NONFLAMMABLE FUSIBLE     |
|           | : RW    | NONFLAMMABLE WIREWOUND   |
|           | : RS    | NONFLAMMABLE METAL OXIDE |
|           | : RB    | NONFLAMMABLE CEMENT      |
| COIL      | : LF-8L | MICRO INDUCTOR           |
| CAPACITOR | : TA    | TANTALUM                 |
|           | : PS    | STYROL                   |
|           | : PP    | POLYPROPYLENE            |
|           | : PT    | MYLAR                    |
|           | : MPS   | METALIZED POLYESTER      |
|           | : MPP   | METALIZED POLYPROPYLENE  |
|           | : ALB   | BIPOLAR                  |
|           | : ALT   | HIGH TEMPERATURE         |
|           | : ALR   | HIGH RIPPLE              |

**Note:**

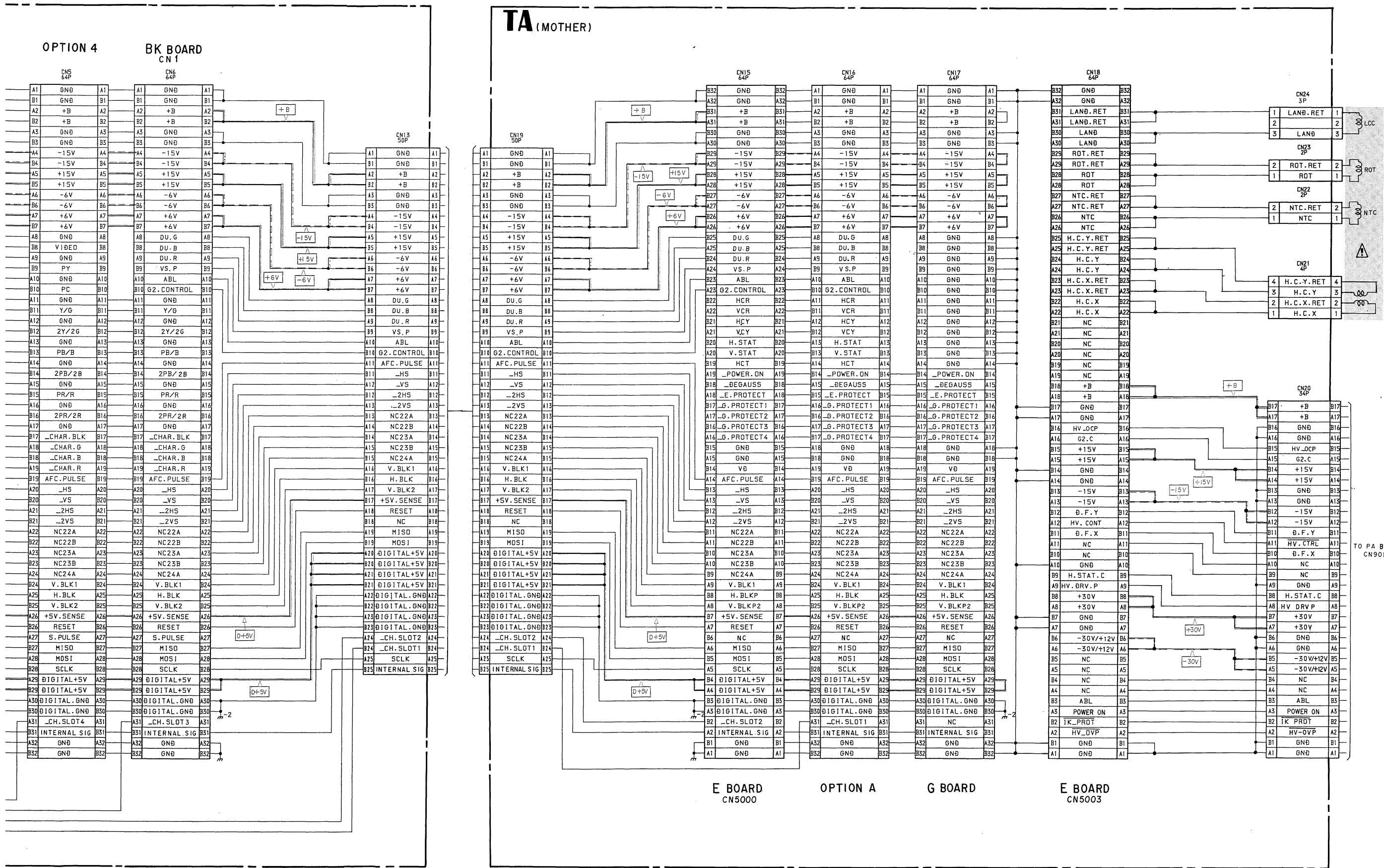
The components identified by shading and mark **△** are critical for safety. Replace only with part number specified.

**Note:**

Les composants identifiés par un tramé et une marque **△** sont critiques pour la sécurité. Ne les remplacer que par une pièce portant le numéro spécifié.



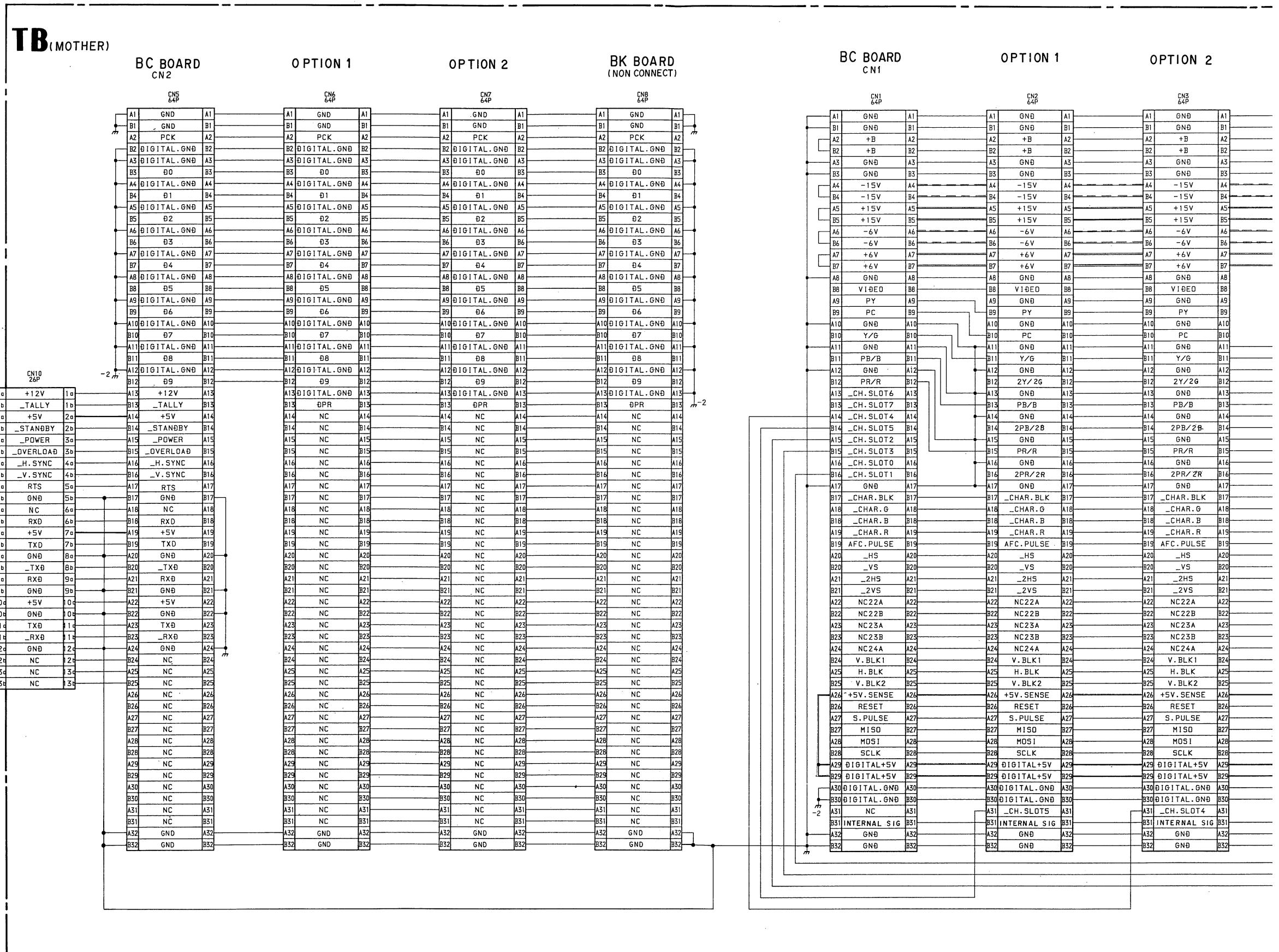


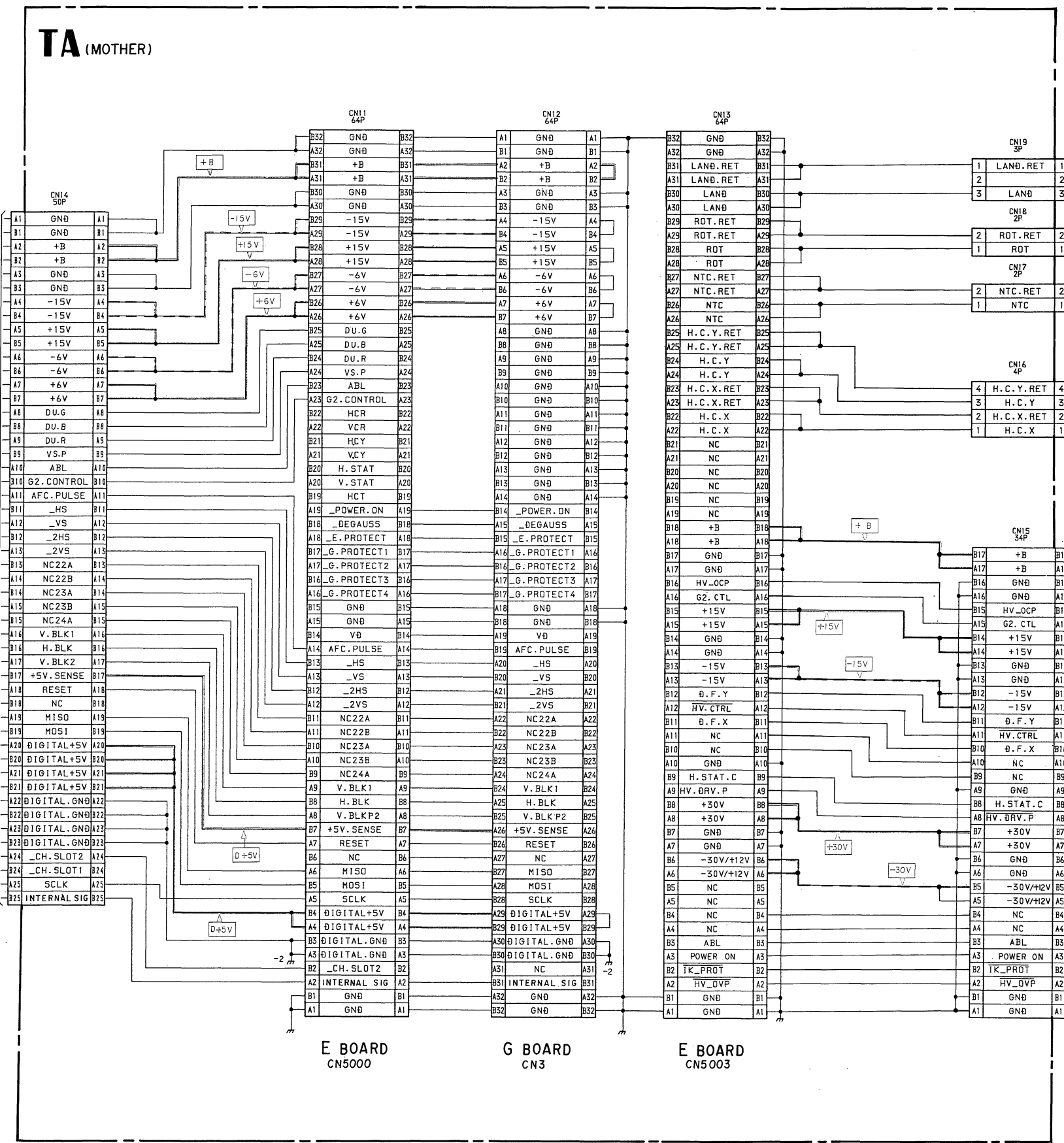
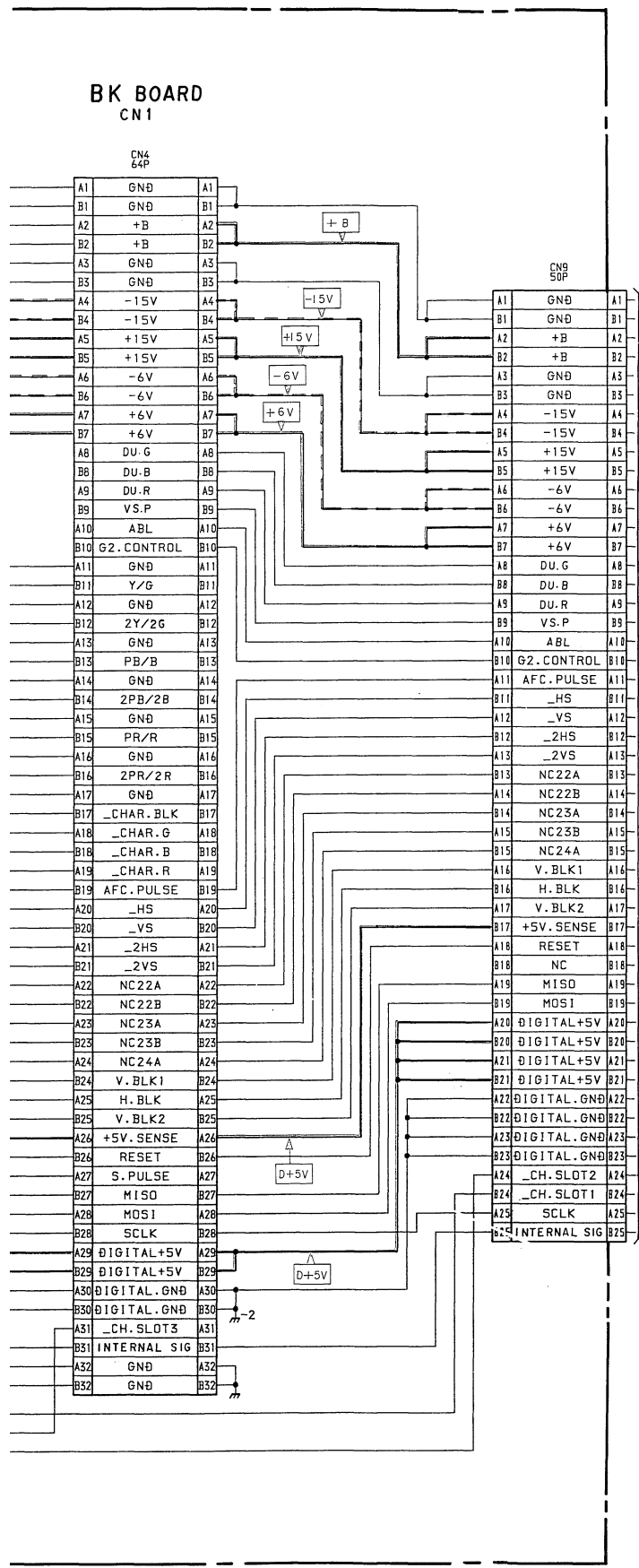






• TA (MOTHER), TB (MOTHER) BOARD (BVM-14E1E/14E1U/14F1E/14F1U)



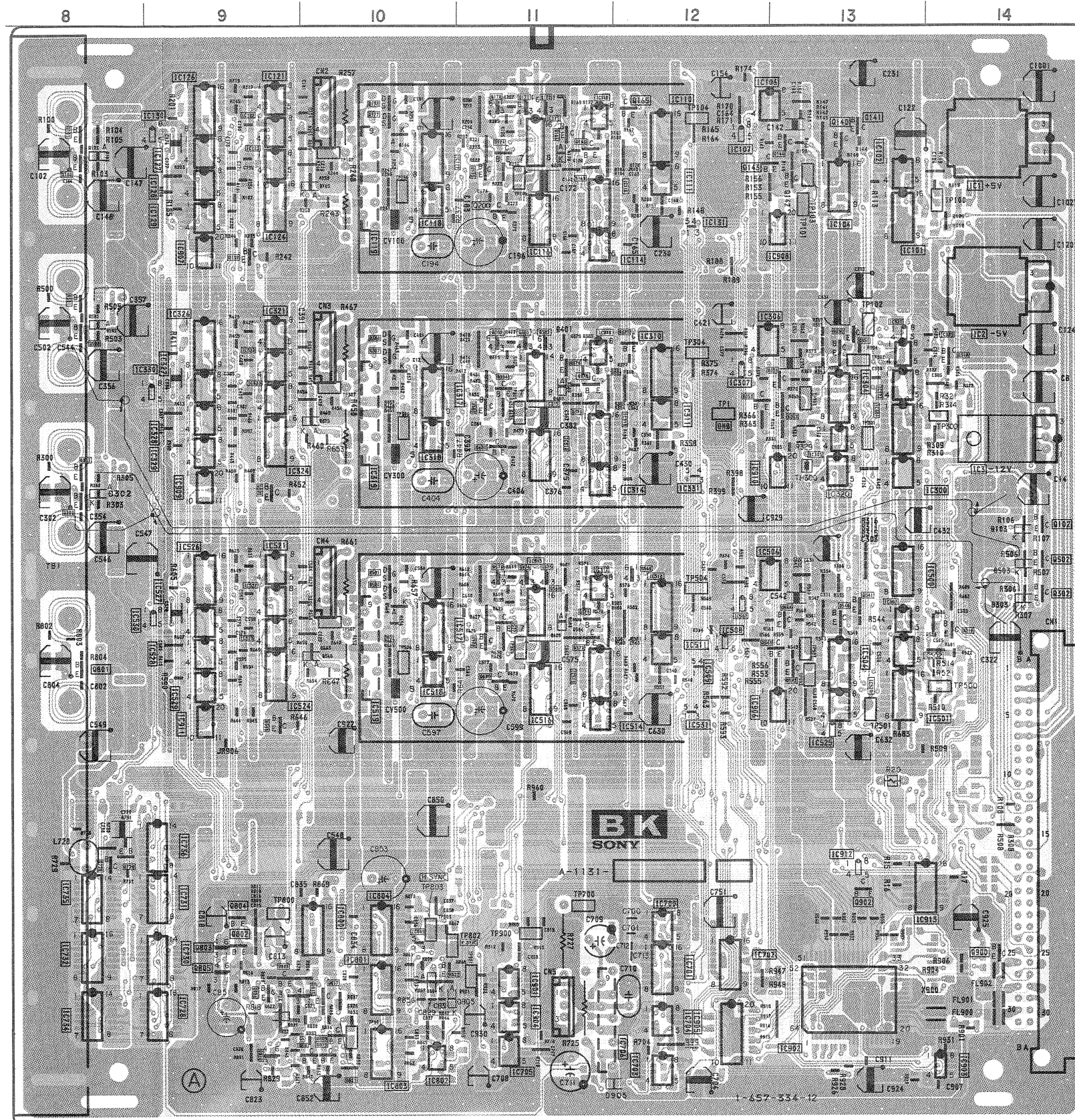






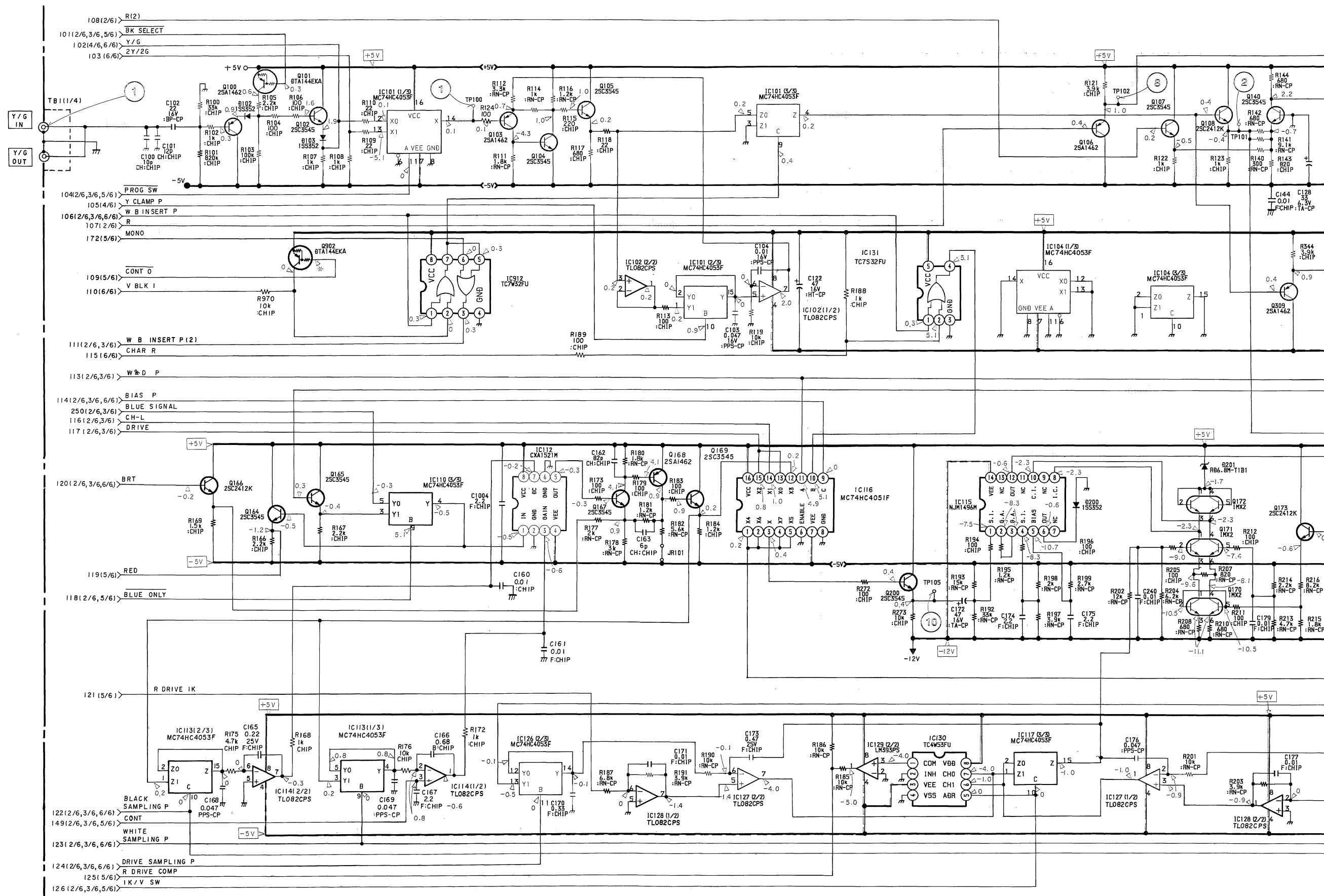


— BK BOARD — <Component Side>



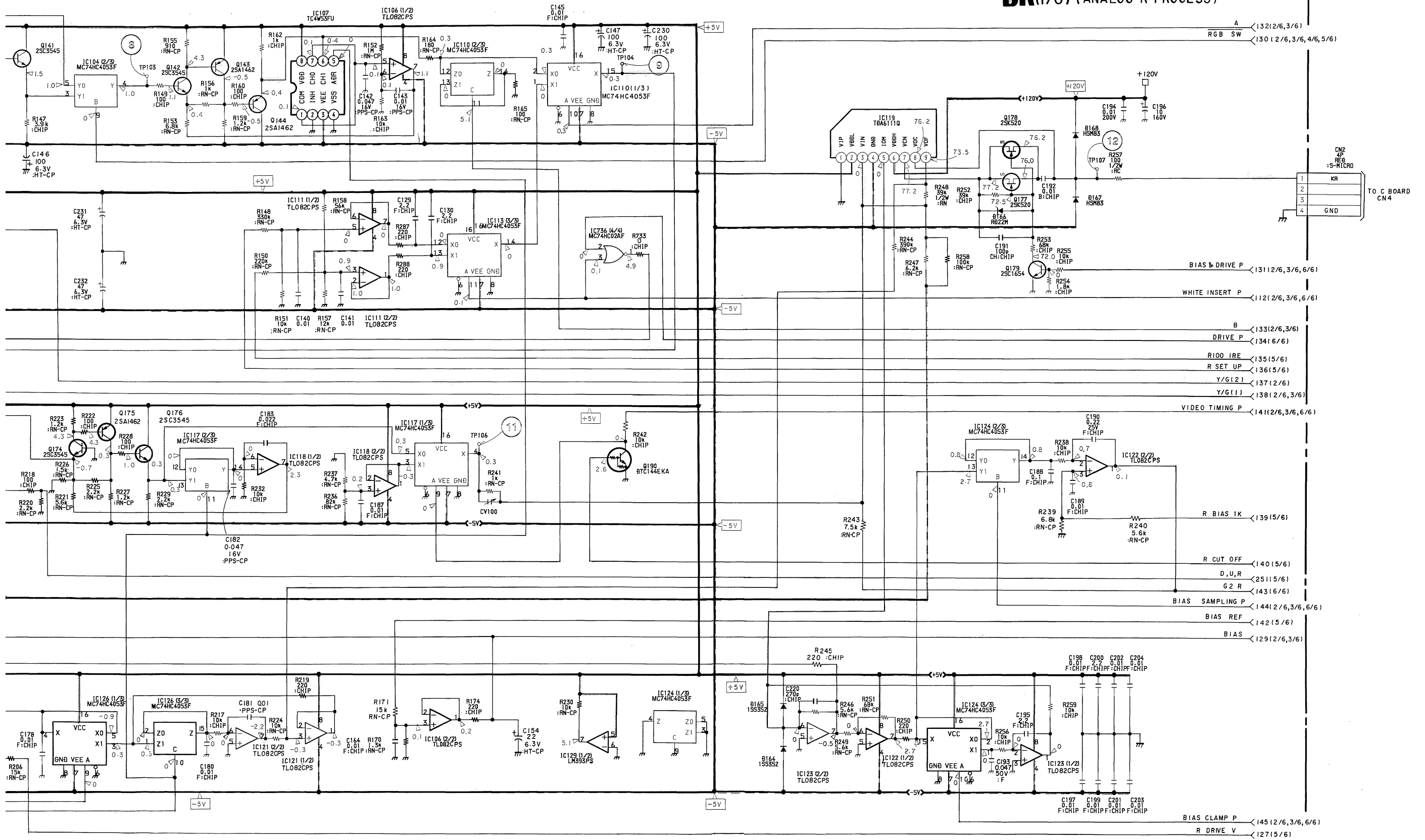
ANALOG R PROCESSOR BOARD (1/6)

- Refer to page 5-31 for Function of Semiconductor
- Refer to page 5-30 for Waveforms





BK(1/6) (ANALOG R PROCESS)



1

2

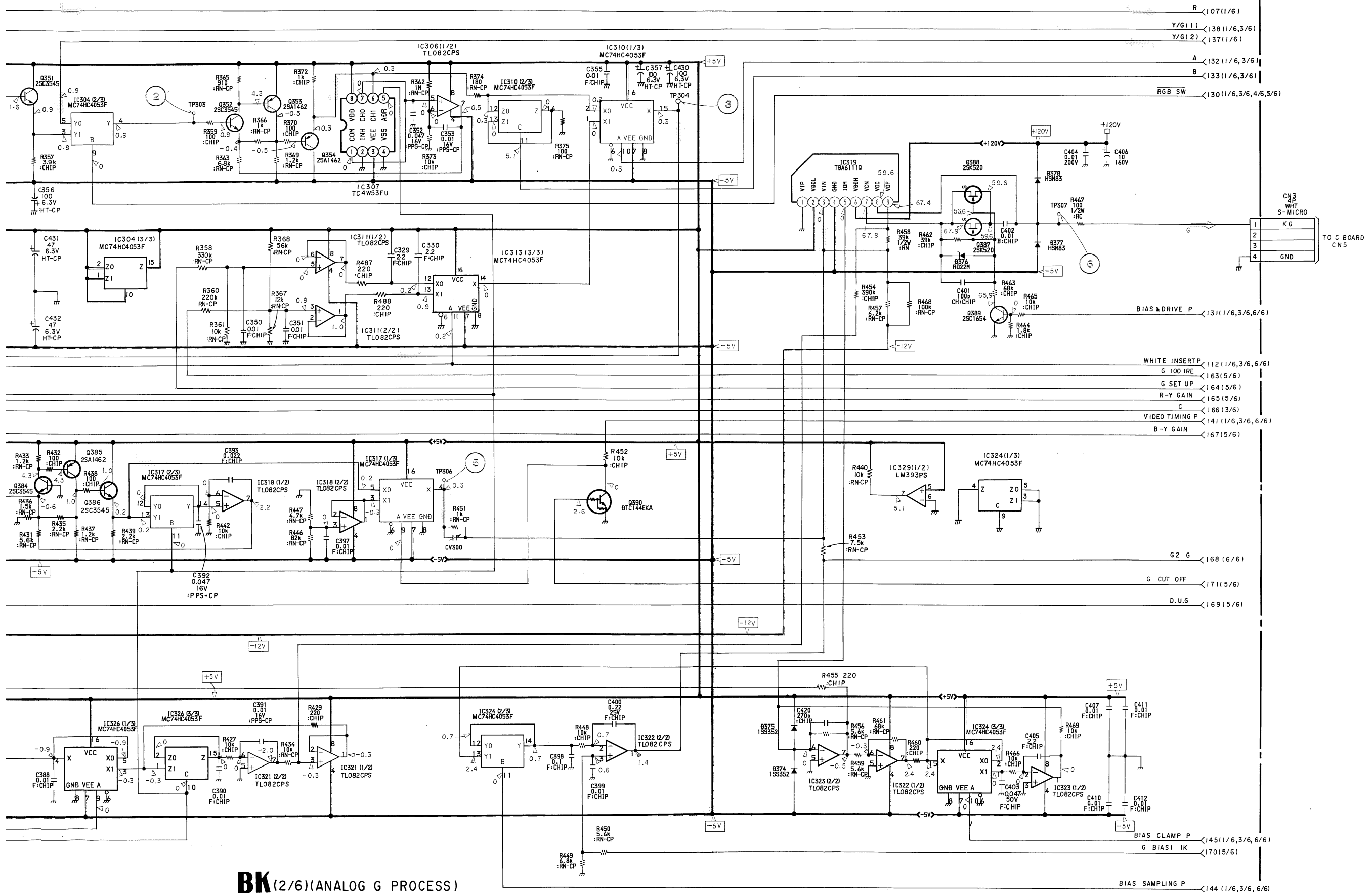
3

4

5

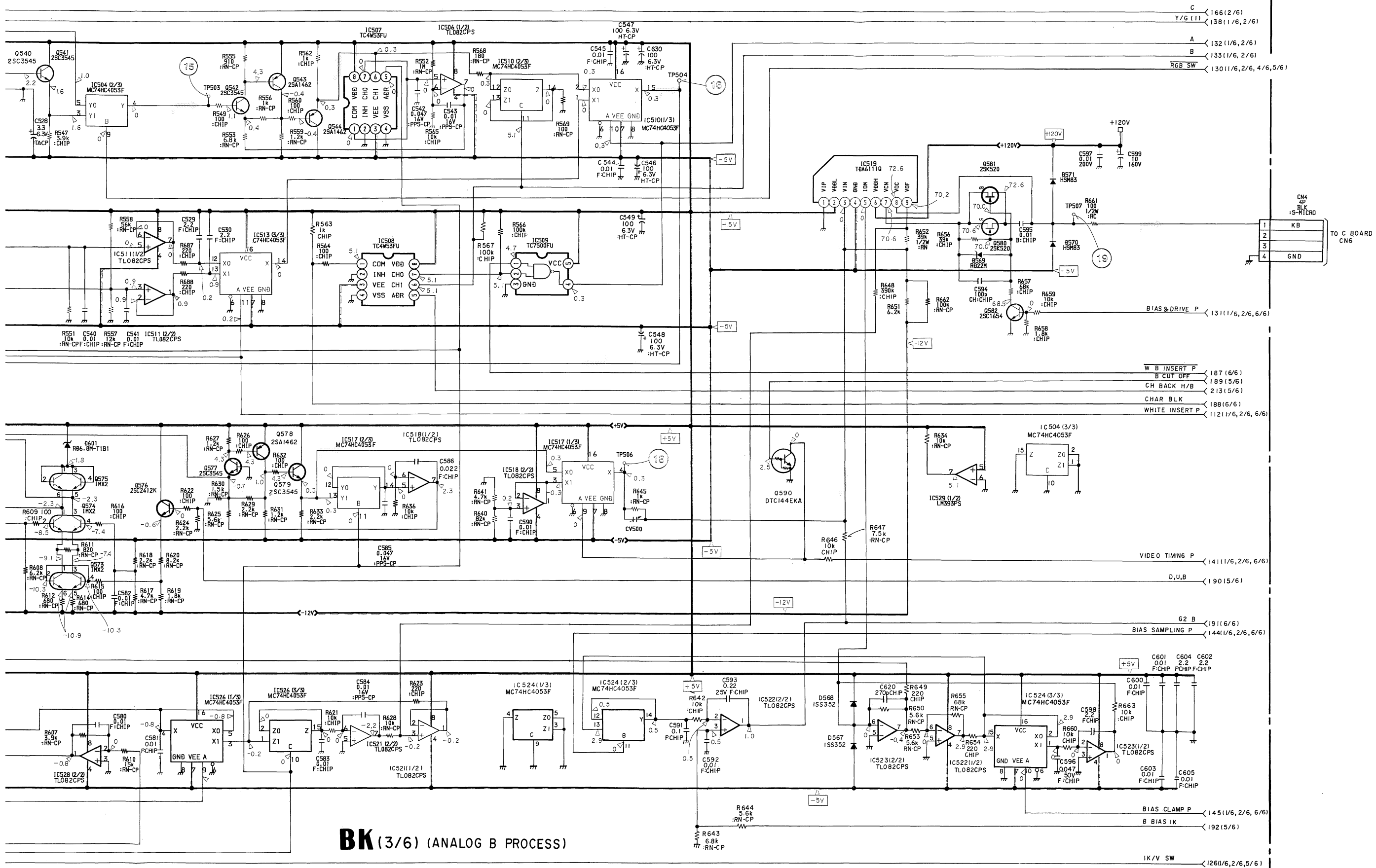


- Refer to page 5-31 for Function of Semiconductor
- Refer to page 5-30 for Waveforms
- Refer to page 5-16 for Printed Wiring Board



BK(2/6)(ANALOG G PROCESS)



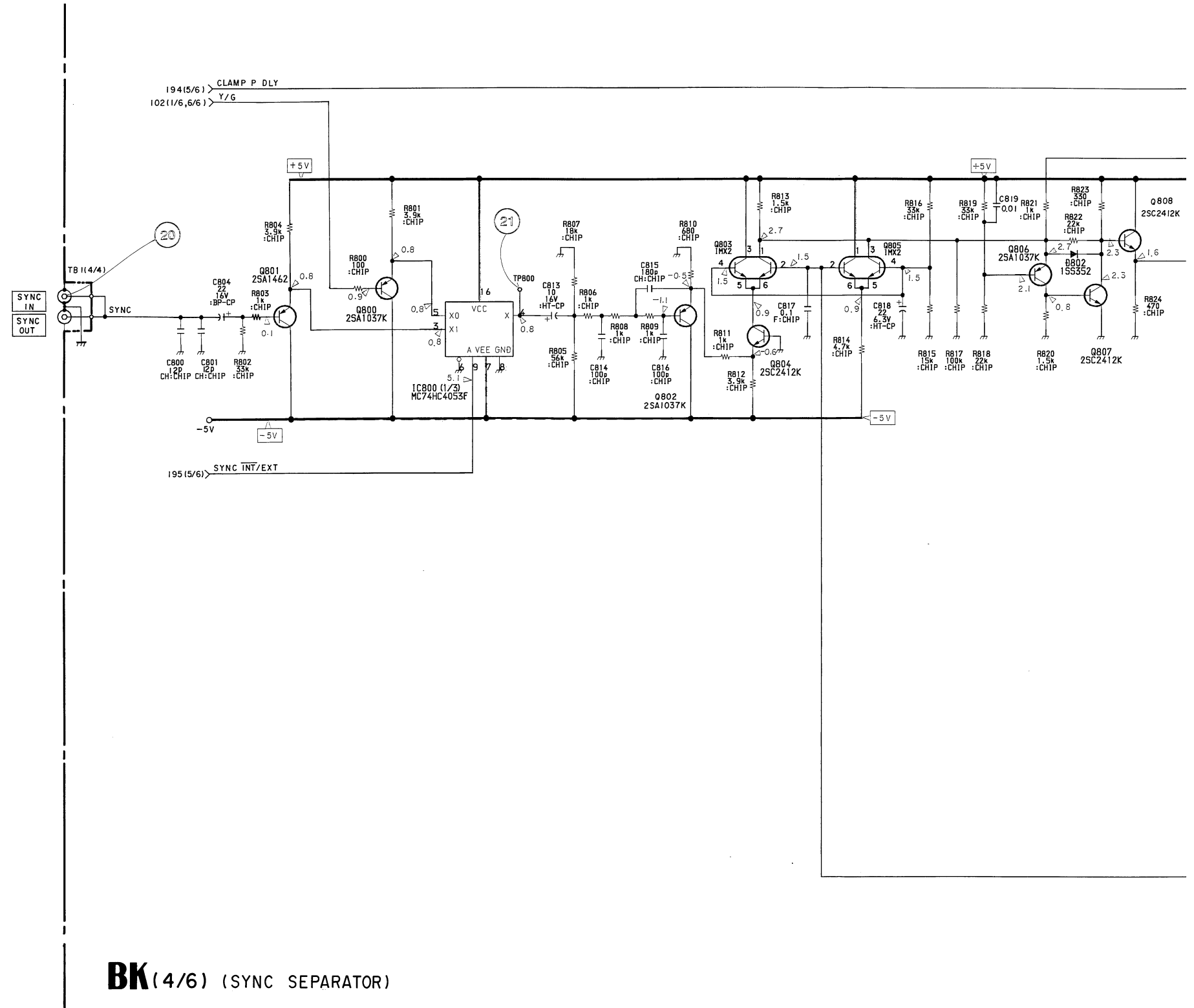


BK (3/6) (ANALOG B PROCESS)

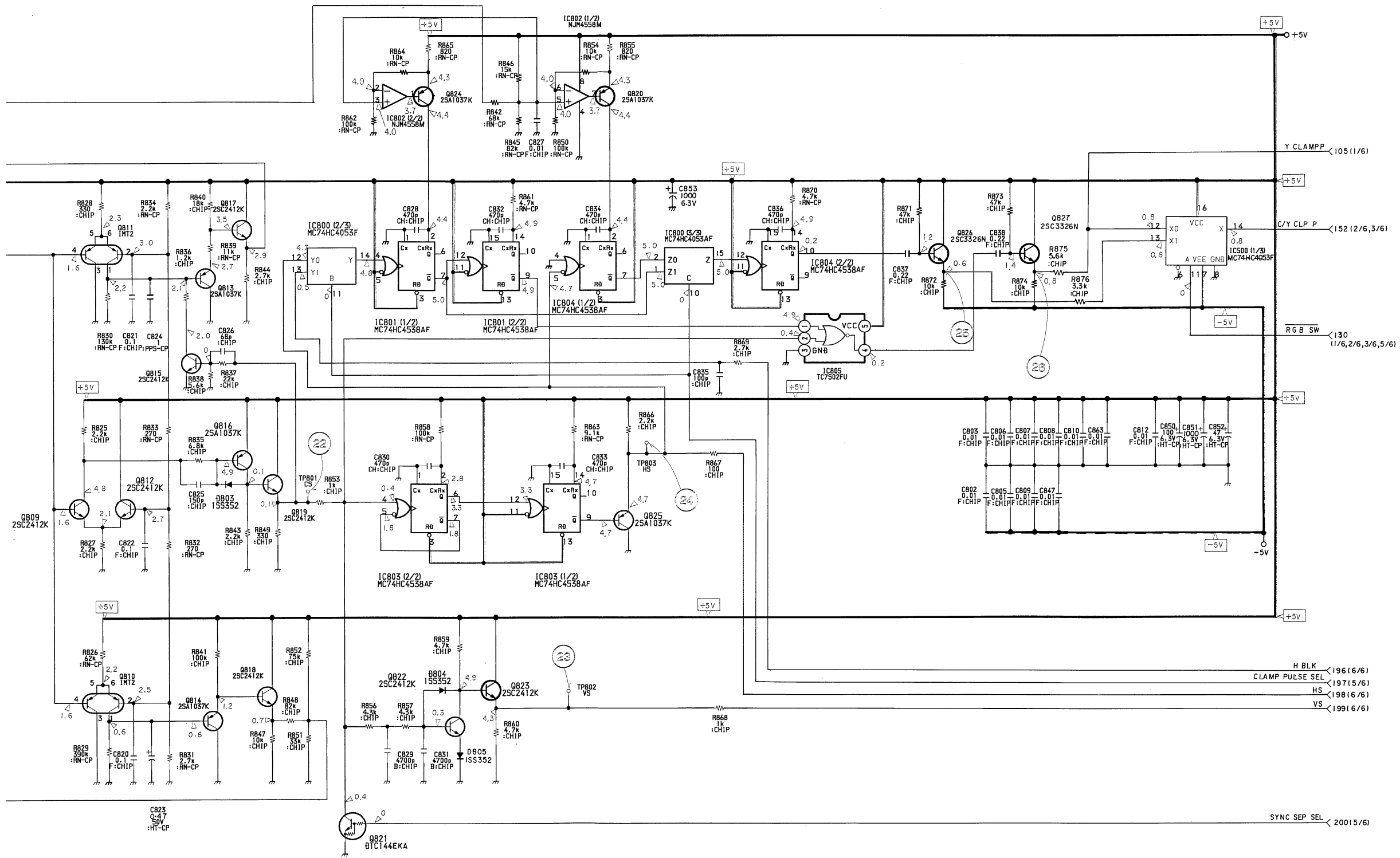
- Refer to page 5-31 for Function of Semiconductor
- Refer to page 5-30 for Waveforms
- Refer to page 5-16 for Printed Wiring Board

- Refer to page 5-31 for Function of Semiconductor
- Refer to page 5-30 for Waveforms
- Refer to page 5-16 for Printed Wiring Board

• BK (SYNC SEPARATOR) BOARD (4/6)



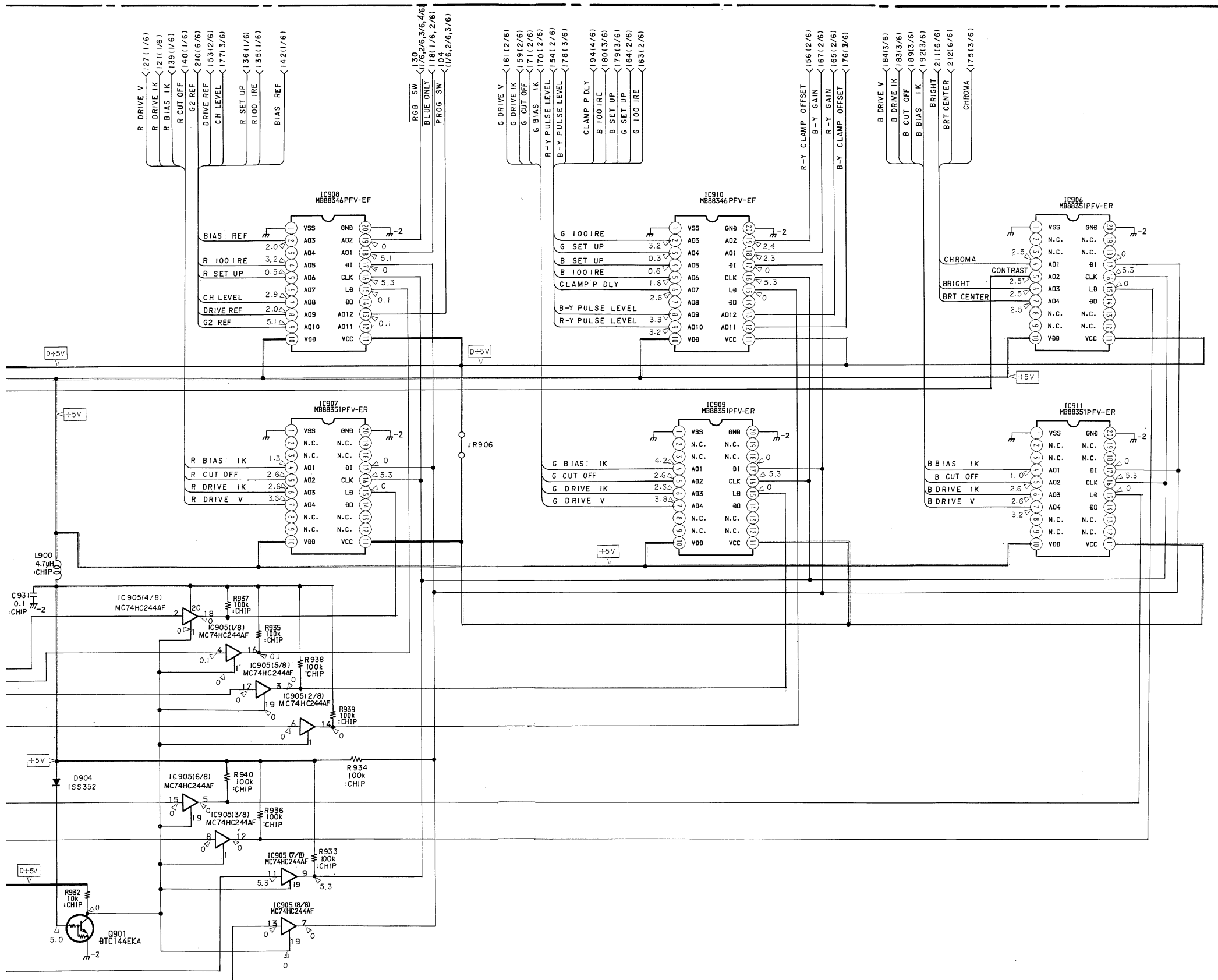
BK (4/6) (SYNC SEPARATOR)



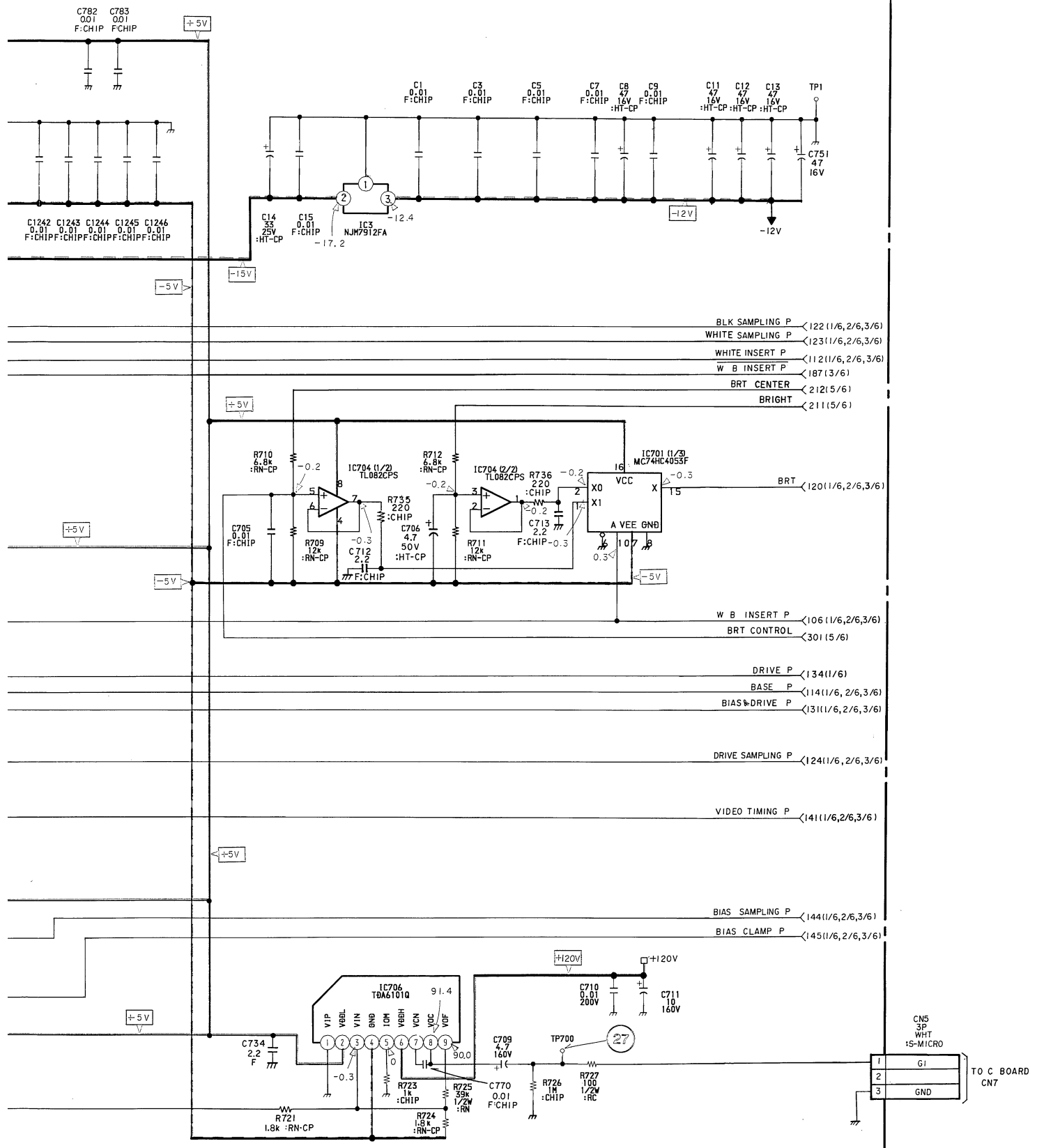
1  
2  
3  
4  
5









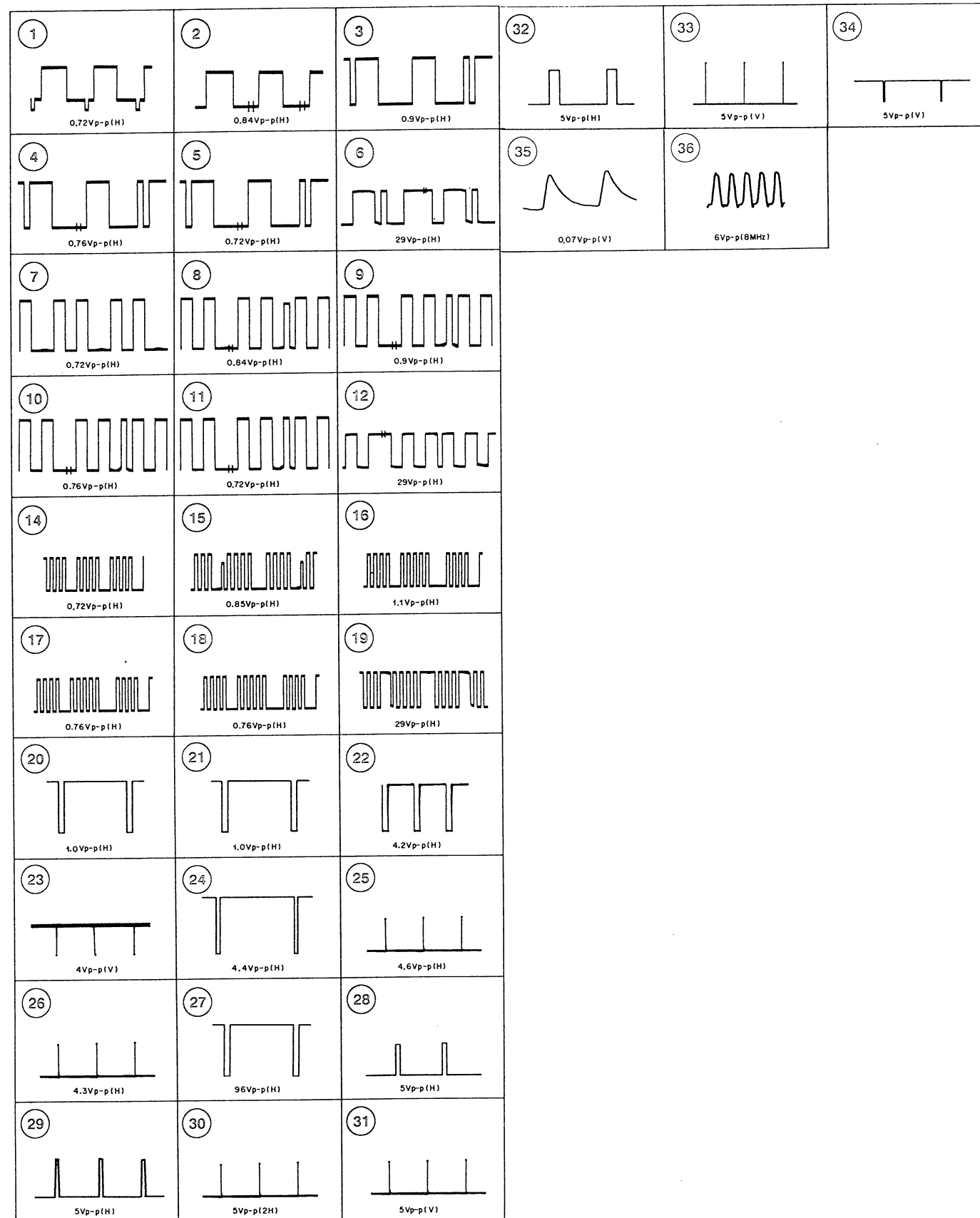


BK (6/6) (TIMING GENERATOR)

- BLK SAMPLING P <122 (1/6, 2/6, 3/6)
- WHITE SAMPLING P <123 (1/6, 2/6, 3/6)
- WHITE INSERT P <112 (1/6, 2/6, 3/6)
- W B INSERT P <187 (3/6)
- BRT CENTER <212 (5/6)
- BRIGHT <211 (5/6)
- BRT <120 (1/6, 2/6, 3/6)
- W B INSERT P <106 (1/6, 2/6, 3/6)
- BRT CONTROL <301 (5/6)
- DRIVE P <134 (1/6)
- BASE P <114 (1/6, 2/6, 3/6)
- BIAS DRIVE P <131 (1/6, 2/6, 3/6)
- DRIVE SAMPLING P <124 (1/6, 2/6, 3/6)
- VIDEO TIMING P <141 (1/6, 2/6, 3/6)
- BIAS SAMPLING P <144 (1/6, 2/6, 3/6)
- BIAS CLAMP P <145 (1/6, 2/6, 3/6)

1  
2  
3  
4  
5

• BK BOARD Waveforms



BK BOARD (1/3)

Function of Semiconductor

1C1	LM2940CT-5.0	+5V REG	1C501	MC74HC4053F	PROG. PULSE INSERT SW
2	LM2990T-5.0	-5V REG	502	TL082CPS-E20	B-Y/B CLAMP, B-Y GAIN CONT
3	NJM7912FA	-12V REG	503	CXA1521M-T4	B-Y GAIN CONTROL
101	MC74HC4053F	PROG. SW, PULSE INS., Y/G CLAMP	504	MC74HC4053F	PROG SW, B-Y GAIN CONT
102	TL082CPS-E20	Y/G CLAMP	506	TL082CPS-E20	BUFFER, B CLAMP
104	MC74HC4053F	RGB SWITCH	507	TC4W53FU	B CLAMP
106	TL082CPS-E20	BUFFER, R CLAMP	508	TC4W53FU	CHAR BACK SW
107	TC4W53FU	R CLAMP	509	TC7S00FU	CHAR BLK INSERT
110	MC74HC4053F	HALF BLK SW, PULSE INSERT	510	MC74HC4053F	HALF BLK, PULSE INSERT SW
111	TL082CPS-E20	BUFFER	511	TL082CPS-E20	BUFFER
112	CXA1521M-T4	CONT. BRT CONTROL	512	CXA1521M-T4	CONT. BRT CONTROL
113	MC74HC4053F	CONT. BRT CONTROL, R REF SW	513	MC74HC4053F	CONT. BRT CONTROL, B REF SW
114	TL082CPS-E20	CONT. BRT CONTROL	514	TL082CPS-E20	CONT. BRT CONTROL
115	NJM1496M-TE2	R DRIVE AMP	515	NJM1496M-TE2	B DRIVE AMP
116	MC74HC4051F	PULSE INSERT	516	MC74HC4051F	PULSE INSERT
117	MC74HC4053F	SR DRIVE AMP, IK/V, CUTOFF SW	517	MC74HC4053F	IK/V, CUTOFF SW, AMP
118	TL082CPS-E20	R DRIVE AMP, BUFFER	518	TL082CPS-E20	B DRIVE AMP, BUFFER
119	TDA6111Q	R VIDEO OUT	519	TDA6111Q	B VIDEO OUT
121	TL082CPS-E20	R DRIVE (IK/V) CONTROL	520	TL082CPS-E20	B DRIVE (IK/V) CONTROL
122	TL082CPS-E20	R BIAS CONT, R IK CLAMP	521	TL082CPS-E20	B DRIVE (V) CONTROL
123	TL082CPS-E20	R IK CLAMP	522	TL082CPS-E20	B IK CLAMP, B BIAS CONTROL
124	MC74HC4053F	R BIAS CONT, R IK CLAMP	523	TL082CPS-E20	B IK CLAMP
126	MC74HC4053F	R DRIVE (IK/V) CONTROL	524	MC74HC4053F	B IK CLAMP, B BIAS CONTROL
127	TL082CPS-E20	R DRIVE (IK/V) CONTROL	525	TC4W53FU	B-Y GAIN CONTROL
128	TL082CPS-E20	R DRIVE (IK/V) CONTROL	526	MC74HC4053F	B DRIVE (IK/V) CONTROL
129	LM393PS-T5L	R DRIVE COMPARATOR	527	TL082CPS-E20	B DRIVE (IK/V) CONTROL
130	TC4W53FU	IK/V SWITCH	528	TL082CPS-E20	B DRIVE (IK/V) CONTROL
131	TC7S32FU	CHAR R	529	LM393PS-T5L	B DRIVE COMPARATOR
300	TL082CPS-E20	BUFFER	530	TC4W53FU	IK/V SWITCH
301	MC74HC4053F	PROG. SW, R-Y/R CLAMP, PULSE INSERT	531	TC7S32FU	CHAR B
302	TL082CPS-E20	R-Y/R CLAMP	700	LM393PS-T5L	COMPARATOR
303	CXA1521M-T4	R-Y GAIN CONTROL	701	MC74HC4053F	SAMPLING HOLD, BRT REF SW
304	MC74HC4053F	RGB SW, R-Y GAIN CONTROL	702	MC74HC4052F	SIGNAL SELECT SW
305	CXA1211M-T4	G-Y MATRIX AMP	703	LM393PS-T5L	SAMPLING P SEP
306	TL082CPS-E20	BUFFER, G CLAMP	704	TL082CPS-E20	BUFFER
307	TC4W53FU	G CLAMP	705	TL082CPS-E20	G2 CONTROL
310	MC74HC4053F	HALF BLK SW, PULSE INSERT	706	TDA6101Q	BLK AMP
311	TL082CPS-E20	BUFFER	728	MC74HC00AF	PULSE GENERATOR
312	CXA1521M-T4	CONT. BRT CONTROL	730	MC74HC02AF	PULSE GENERATOR
313	MC74HC4053F	CONT. BRT CONTROL, G REF SW	731	MC74HC14AF	PULSE GENERATOR
314	TL082CPS-E20	CONT. BRT CONTROL	732	MC74HC175F	PULSE GENERATOR
315	NJM1496M-TE2	G DRIVE AMP	734	MC74HC11F	PULSE GENERATOR
316	MC74HC4051F	PULSE INSERT	735	MC74HC02AF	PULSE GENERATOR
317	MC74HC4053F	G DRIVE AMP, IK/V, CUTOFF SW	736	MC74HC02AF	PULSE GENERATOR
318	TL082CPS-E20	G DRIVE AMP, BUFFER	800	MC74HC4053F	INT/EXT SYNC, HS/H BLK SW
319	TDA6111Q	G VIDEO OUT	801	MC74HC4538AF	CLAMP PULSE GEN
320	TL082CPS-E20	R-Y GAIN CONTROL	802	NJM4558M-T2	CLAMP PULSE DLY
321	TL082CPS-E20	G DRIVE (V) CONTROL	803	MC74HC4538AF	H SYNC SEP
322	TL082CPS-E20	G BIAS CONT, G IK CLAMP	804	MC74HC4538AF	CLAMP PULSE GEN
323	TL082CPS-E20	G IK CLAMP	805	TC7S02FU	CLAMP PULSE GEN
324	MC74HC4053F	G BIAS CONT, G IK CLAMP	900	MC74HC125AF	BUFFER
325	TC4W53FU	R-Y GAIN CONTROL	901	TL082CPS-E20	A. B. L, CONT BUFFER
326	MC74HC4053F	G DRIVE (IK/V) CONTROL	902	MB88613PF-SUB02	SUB MICROCOMPUTER
327	TL082CPS-E20	G DRIVE (IK/V) CONTROL	903	X25040S-C7000	EEP ROM
328	TL082CPS-E20	G BUFFER (IK/V) CONTROL	904	LM393PS-T5L	OVERLOAD COMPARATOR
329	LM393PS	G DRIVE COMPARATOR	905	MC74HC244AF	BUFFER
330	TC4W53FU	IK/V SWITCH	906	MB88351PFV-ER	DAC
331	TC7S32FU	CHAR G	907	MB88351PFV-ER	DAC
500	MC74HC4053F	CLAMP P, B-Y REF, R-Y REF SW	908	MB88346BPFV-EF	DAC

BK BOARD (2/3)

1C909	MB88351PFV-ER	DAC	Q379	2SC3545	CONT. BRT CONTROL
910	MB88346BPFV-EF	DAC	380	1MX2	G DRIVE AMP
911	MB88351PFV-ER	DAC	381	1MX2	G DRIVE AMP
912	TC7W32FU-TE12L	MONO SW	382	1MX2	G DRIVE AMP
913	MC74HC4053F	D. U SW	383	2SC2412K-QR	G DRIVE AMP
			384	2SC3545	G DRIVE AMP
Q100	2SA1462	Y/G BUFFER	385	2SA1462	G DRIVE AMP
101	DTA144EKA	BK SELECT SW	386	2SC3545	G DRIVE AMP
102	2SC3545	Y/G BUFFER	387	2SK520K44K45	TRANSIENT OFF SW
103	2SA1462	Y/G CLAMP	388	2SK520K44K45	TRANSIENT OFF SW
104	2SC3545	Y/G CLAMP	389	2SC1654	TRANSIENT OFF SW
105	2SC3545	Y/G CLAMP	390	DTC144EKA	CUTOFF SW
106	2SA1462	R BUFFER	400	2SC3545	G BUFFER
107	2SC3545	R-Y BUFFER	500	2SA1462	B-Y/B BUFFER
108	2SC2412K-QR	Y BUFFER	501	DTA144EKA	BK SELECT SW
140	2SC3545	Y-R-Y MIX	502	2SC3545	B-Y/B BUFFER
141	2SC3545	Y-R-Y MIX	503	2SA1462	B-Y/B CLAMP
142	2SC3545	R CLAMP	504	2SC3545	B-Y/B CLAMP
143	2SA1462	R CLAMP	505	2SC3545	B-Y/B CLAMP
144	2SA1462	R CLAMP	506	2SA1462	B BUFFER
164	2SC3545	R BUFFER	507	2SC3545	B-Y BUFFER
165	2SC3545	R BUFFER	510	2SC3545	B-Y GAIN CONTROL
166	2SC2412K-QR	BRT BUFFER	540	2SC3545	Y-B-Y MIX
167	2SC3545	CONT. BRT CONTROL	541	2SC3545	Y-B-Y MIX
168	2SA1462	CONT. BRT CONTROL	542	2SC3545	B CLAMP
169	2SC3545	CONT. BRT CONTROL	543	2SA1462	B CLAMP
170	1MX2	R DRIVE AMP	544	2SA1462	B CLAMP
171	1MX2	R DRIVE AMP	567	2SC3545	B BUFFER
172	1MX2	R DRIVE AMP	568	1MX2	B BUFFER
173	2SC2412K-QR	R DRIVE AMP	569	2SC2412K-QR	BRT BUFFER
174	2SC3545	R DRIVE AMP	570	2SC3545	CONT. BRT CONTROL
175	2SA1462	R DRIVE AMP	571	2SA1462	CONT. BRT CONTROL
176	2SC3545	R DRIVE AMP	572	2SC3545	CONT. BRT CONTROL
177	2SK520K44K45	TRANSIENT OFF SW	573	1MX2	B DRIVE AMP
178	2SK520K44K45	TRANSIENT OFF SW	574	1MX2	B DRIVE AMP
179	2SC1654	TRANSIENT OFF SW	575	1MX2	B DRIVE AMP
190	DTC144EKA	CUTOFF SW	576	2SC2412K-QR	B DRIVE AMP
200	2SC3545	R BUFFER	577	2SC3545	B DRIVE AMP
300	2SA1462	R-Y/R BUFFER	578	2SA1462	B DRIVE AMP
301	DTA144EKA	BK SELECT SW	579	2SC3545	B DRIVE AMP
302	2SC3545	R-Y/R BUFFER	580	2SK520K44K45	TRANSIENT OFF SW
303	2SA1462	R-Y/R CLAMP	581	2SK520K44K45	TRANSIENT OFF SW
304	2SC3545	R-Y/R CLAMP	582	2SC1654	TRANSIENT OFF SW
305	2SC3545	R-Y/R CLAMP	590	DTC144EKA	CUTOFF SWITCH
306	2SC3545	G-Y MATRIX AMP	600	2SC3545	B BUFFER
307	2SA1462	G-Y MATRIX AMP	700	2SA1037K-QR	G2 R CONTROL
308	2SC2412K-QR	G-Y BUFFER	701	2SA1037K-QR	G2 G CONTROL
309	2SA1462	G BUFFER	702	2SA1037K-QR	G2 B CONTROL
310	2SC3545	R-Y GAIN CONTROL	728	2SC2412K-QR	PULSE GENERATOR
350	2SC3545	Y-G-Y MIX	729	2SC2412K-QR	PULSE GENERATOR
351	2SC3545	Y-G-Y MIX	800	2SA1037K-QR	Y/G BUFFER
352	2SC3545	G CLAMP	801	2SA1037K-QR	EXT SYNC BUFFER
353	2SA1462	G CLAMP	802	2SA1037K-QR	SYNC AGC
354	2SA1462	G CLAMP	803	1MX2	SYNC AGC
374	2SC3545	G BUFFER	804	2SC2412K-QR	SYNC AGC
375	2SC3545	G BUFFER	805	1MX2	SYNC AGC
376	2SC2412K-QR	BTR BUFFER	806	2SA1037K-QR	SYNC AGC
377	2SC3545	CONT. BRT CONTROL	807	2SC2412K-QR	SYNC AGC
378	2SA1462	CONT. BRT CONTROL	808	2SC2412K-QR	SYNC AGC

BK BOARD (3/3)

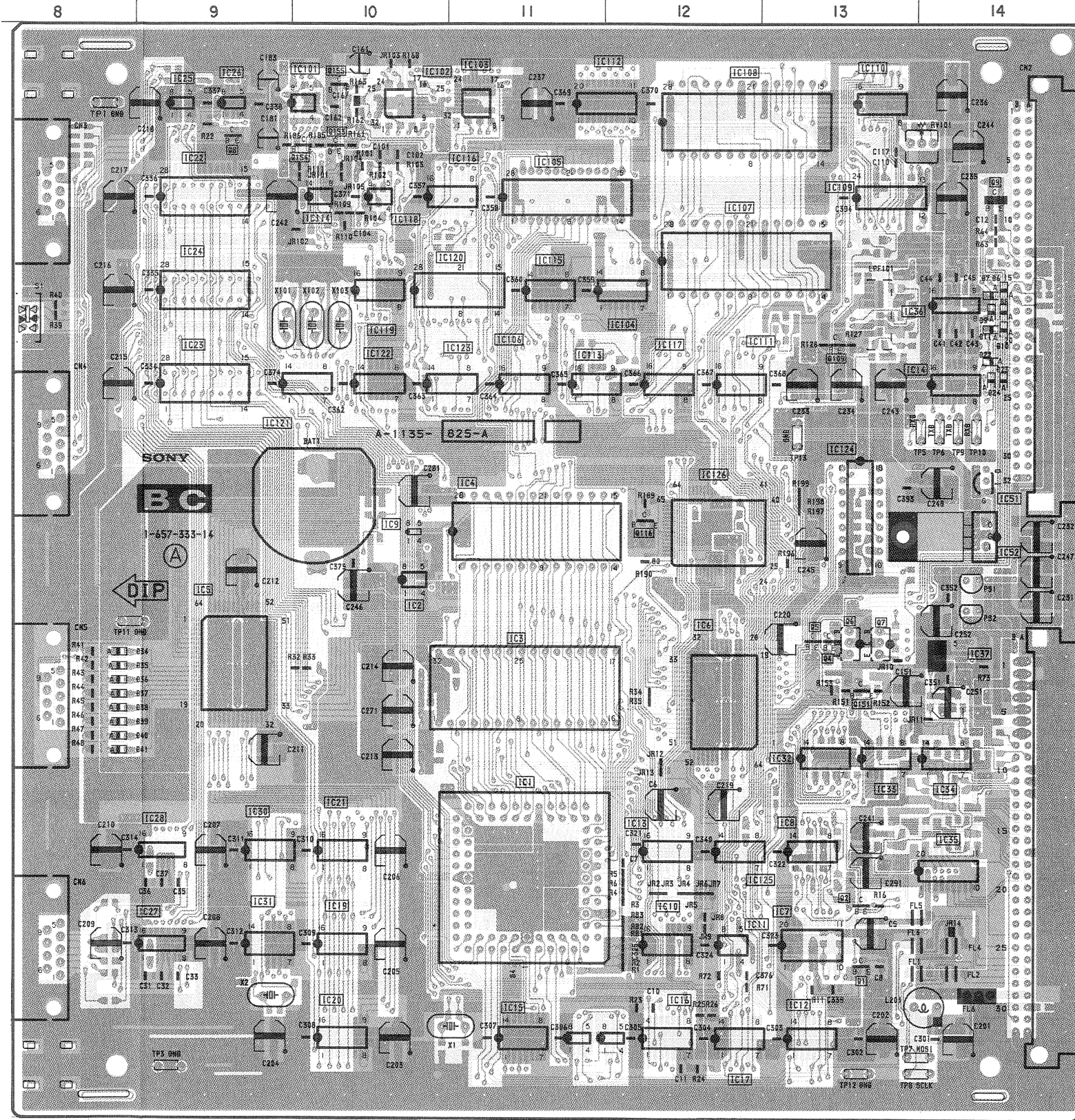
Q809	2SC2412K-QR	SYNC AGC
810	1MT2	SYNC AGC
811	1MT2	SYNC AGC
812	2SC2412K-QR	SYNC AGC
813	2SA1037K-QR	SYNC AGC
814	2SA1037K-QR	SYNC AGC
815	2SC2412K-QR	SYNC AGC
816	2SA1037K-QR	SYNC AGC
817	2SC2412K-QR	SYNC AGC
818	2SC2412K-QR	SYNC AGC
819	2SC2412K-QR	SYNC AGC
820	2SA1037K-QR	CLAMP PULSE DLY
821	DTC144EKA	SYNC SEP SW
822	2SC2412K-QR	V SYNC SEP
823	2SC2412K-QR	V SYNC SEP
824	2SA1037K-QR	CLAMP PULSE DEL
825	2SA1037K-QR	H SYNC SEP
826	2SC4213A	CLAMP PULSE GEN
827	2SC4213A	CLAMP PULSE GEN
900	DTC144EKA	RESET SW
901	DTC144EKA	BUFFER CONTROL
902	DTA144EK	SIGNAL OFF SW
D102	1SS352	DC SHIFT
103	1SS352	PROTECTOR
164	1SS352	PROTECTOR
165	1SS352	PROTECTOR
166	RD22M	PROTECTOR
167	HSM83-TL	PROTECTOR
168	HSM83-TL	PROTECTOR
200	1SS352	DC SHIFT
201	RD6. 8M-B3	R DRIVE AMP
302	1SS352	DC SHIFT
303	1SS352	PROTECTOR
374	1SS352	PROTECTOR
375	1SS352	PROTECTOR
376	RD22M-B3	PROTECTOR
377	HSM83-TL	PROTECTOR
378	HSM83-TL	PROTECTOR
400	1SS352	DC SHIFT
401	RD6. 8M-B1	G DRIVE AMP
502	1SS352	DC SHIFT
503	1SS352	PROTECTOR
567	1SS352	PROTECTOR
568	1SS352	PROTECTOR
569	RD22M-B3	PROTECTOR
570	HSM83-TL	PROTECTOR
571	HSM83-TL	PROTECTOR
600	1SS352	DC SHIFT
601	RD6. 8M-B1	B DRIVE AMP
802	1SS352	SYNC AGC
803	1SS352	SYNC AGC
804	1SS352	V SYNC SEP
805	1SS352	PROTECTOR
900	RD5. 6SB	PROTECTOR
901	1SS352	PROTECTOR
902	1SS352	PROTECTOR
903	1SS352	A. B. L
904	1SS352	BUFFER CONTROL
905	1SS352	BRT CONTROL







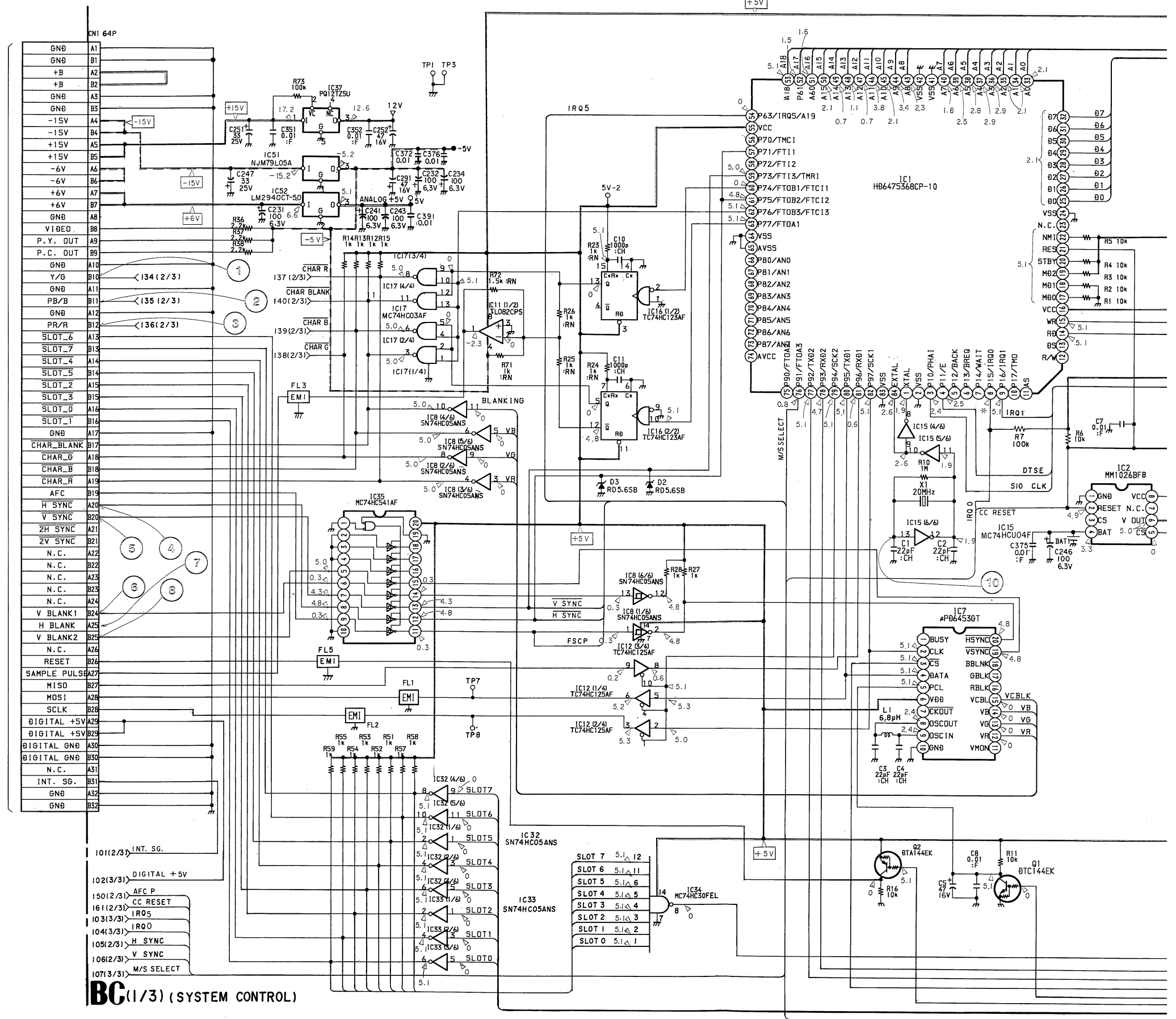
— BC BOARD — <Component Side:



- Refer to page 5-39 for Function of Semiconductor
- Refer to page 5-39 for Waveforms

BC (SYSTEM CONTROL) BOARD (1/3)

TO TB BOARD CNI



BC(1/3) (SYSTEM CONTROL)

1

2

3

4

5

A

B

C

D

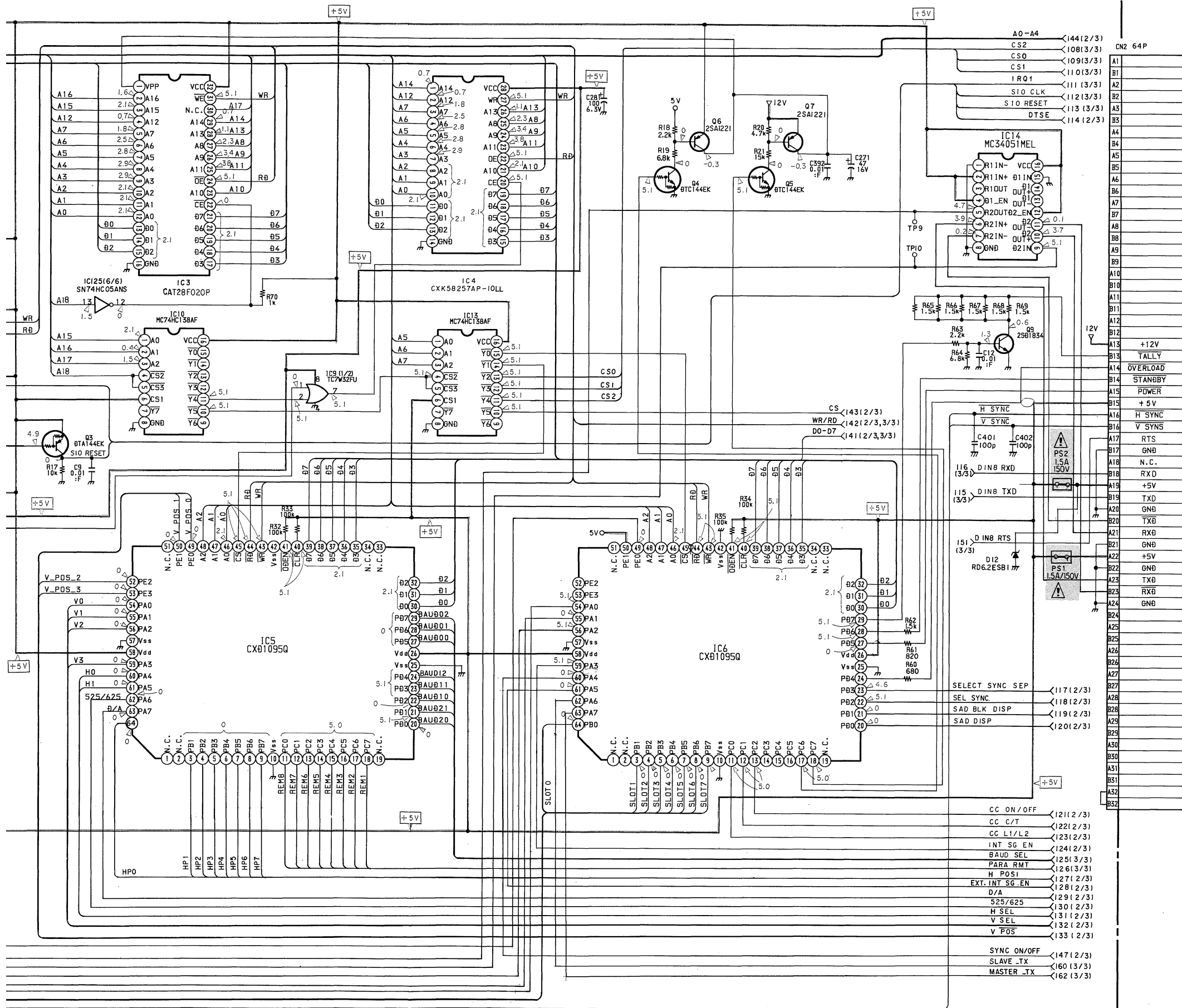
E

F

G

H

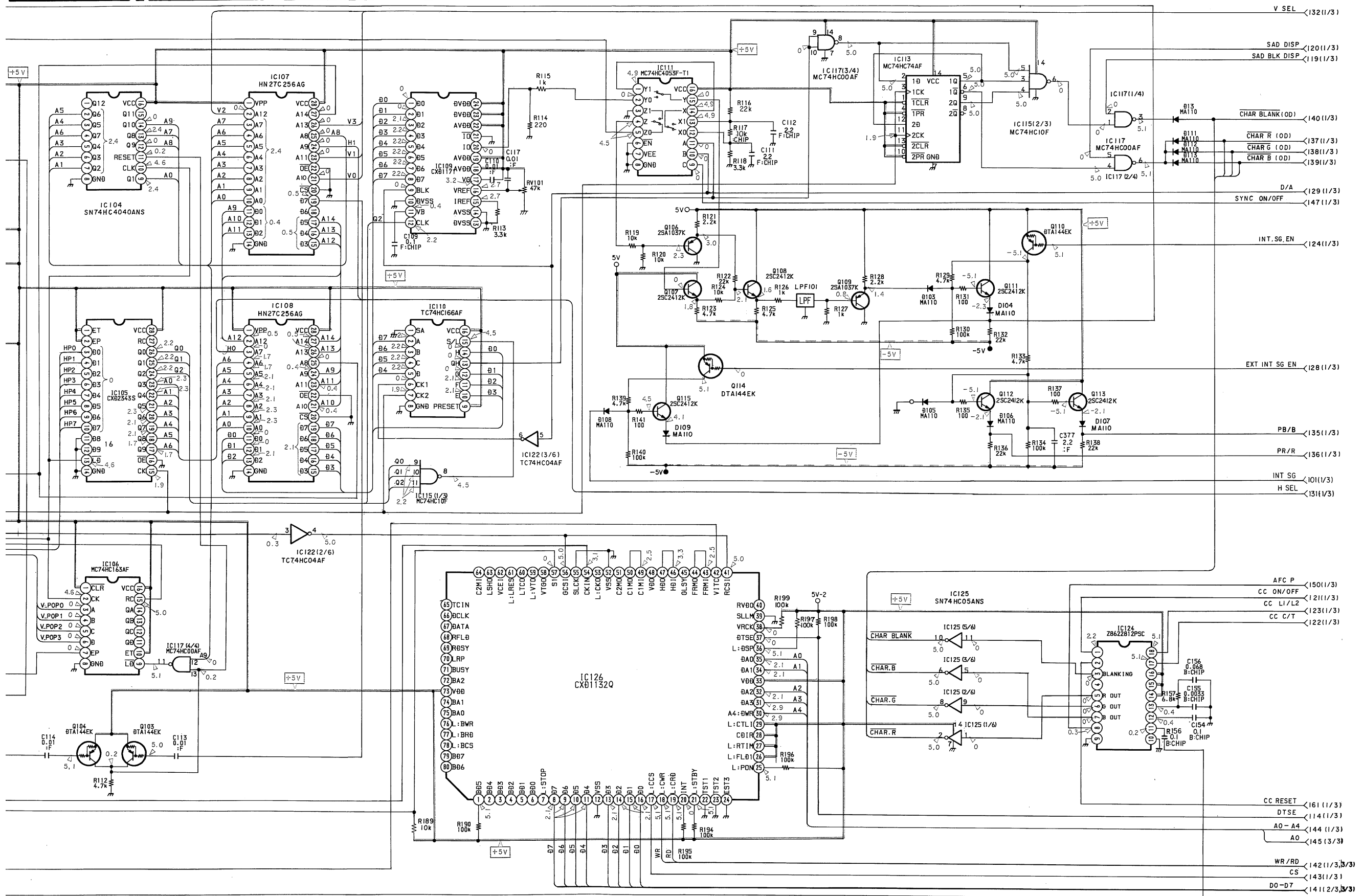




A1	
B1	
A2	
B2	
A3	
B3	
A4	
B4	
A5	
B5	
A6	
B6	
A7	
B7	
A8	
B8	
A9	
B9	
A10	
B10	
A11	
B11	
A12	
B12	
A13	+12V
B13	TALLY
A14	OVERLOAD
B14	STANDBY
A15	POWER
B15	+5V
A16	H SYNC
B16	V SYNS
A17	RTS
B17	GND
A18	N.C.
B18	RXD
A19	+5V
B19	TXD
A20	GND
B20	TXB
A21	RXB
B21	GND
A22	+5V
B22	GND
A23	TXD
B23	RXB
A24	GND
B24	
A25	
B25	
A26	
B26	
A27	
B27	
A28	
B28	
A29	
B29	
A30	
B30	
A31	
B31	
A32	
B32	

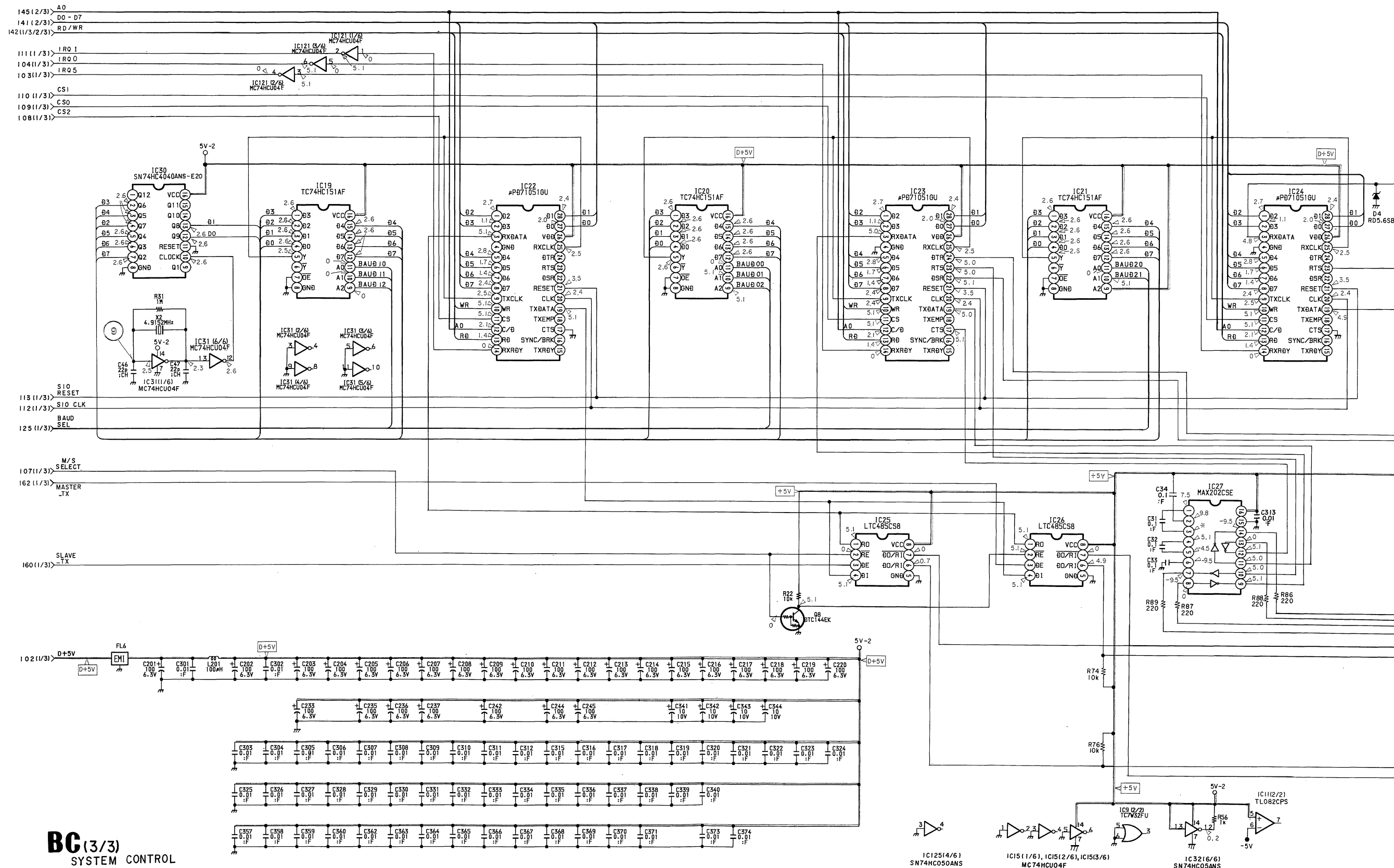
TO TB BOARD CN7





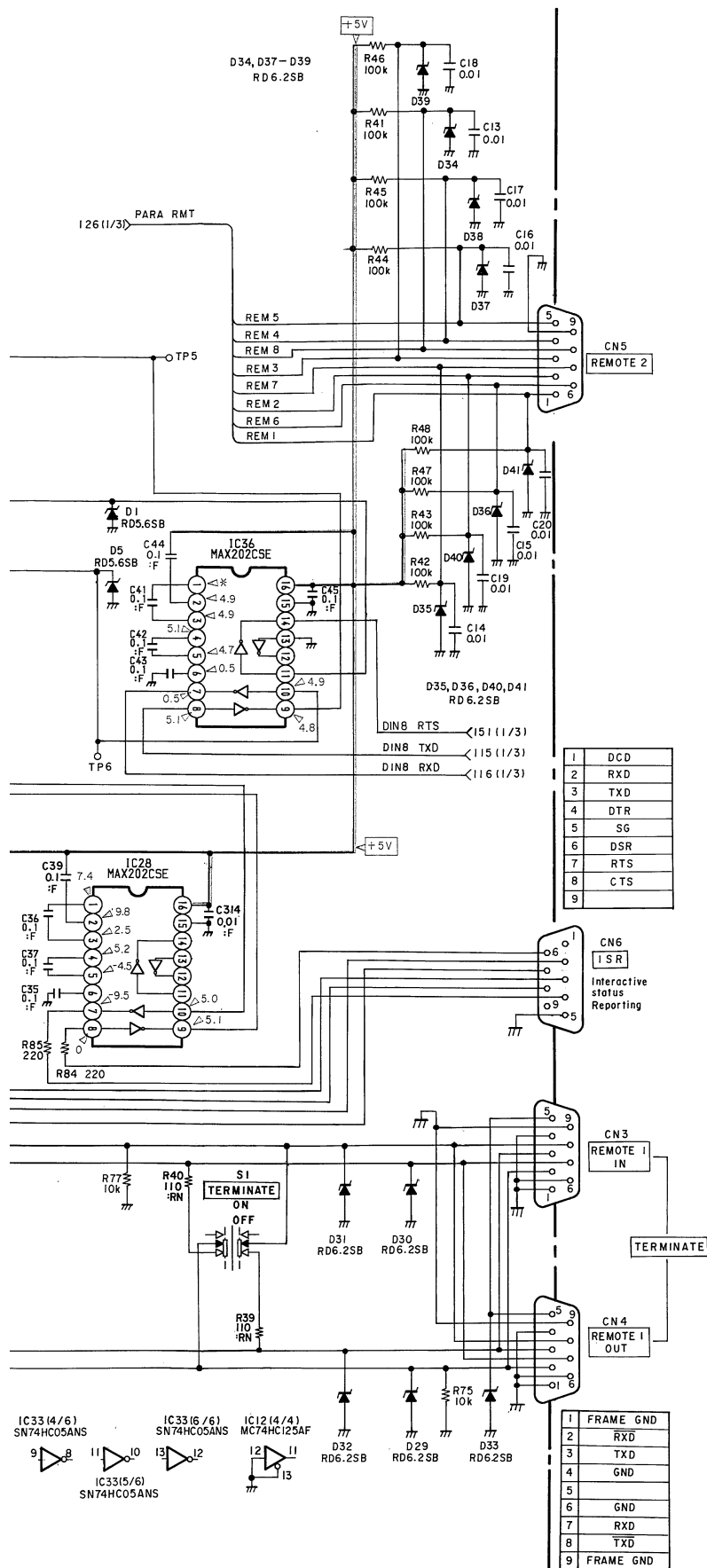
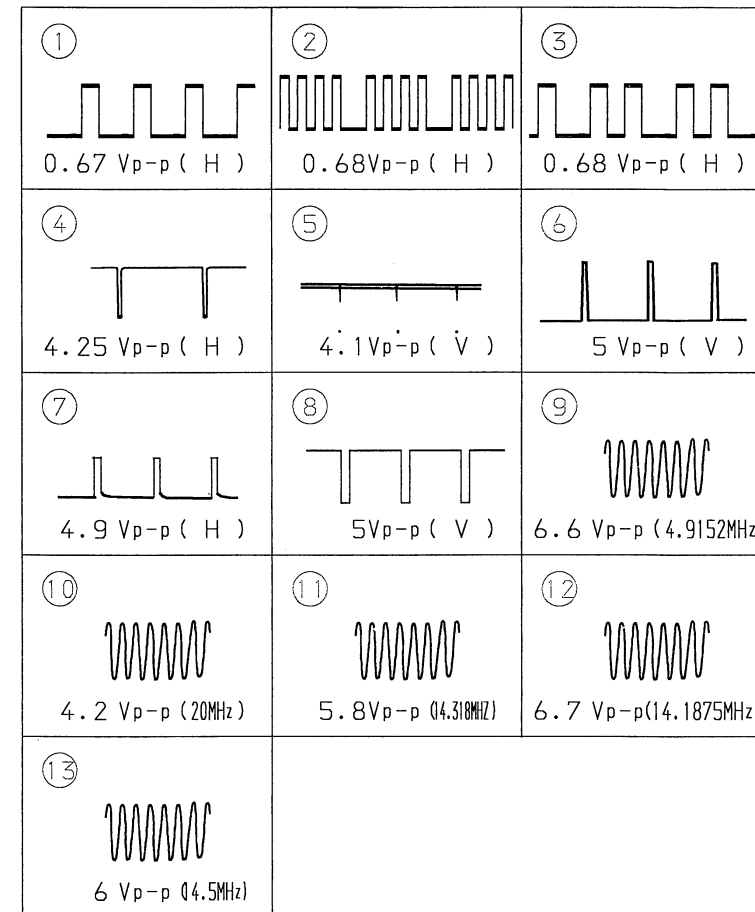
• BC (SYSTEM CONTROL) BOARD (3/3)

• Refer to page 5-32 for Printed Wiring Board



**BC (3/3)**  
SYSTEM CONTROL

• BC BOARD Waveforms



BC BOARD

Function of Semiconductor

IC01	HD6475368CP-10	CPU	Q01	DTC144EK	CHARACTER GEN. RESET
02	MM1026F	RESET	02	DTA144EK	SLAVE CPU RESET
03	CAT28F020P	PROGRAM	03	DTA144EK	SIO RESET
04	CXK58257AF	SRAM	04	DTC144EK	+5V SW
05	CXD1095Q	PARALLEL I/O	05	DTC144EK	+12V SW
06	CXD1095Q	PARALLEL I/O	06	2SA1221	+5V DRIVE
07	UPD64536T-101	CHARACTER GEN.	07	2SA1221	+12V DRIVE
08	SN74HC05ANS	INVERTER	08	DTC144EK	MASTER/SLAVE SW
09	TC7W32FU	SRAM ENABLE	09	2SD1834	TALLY DRIVE
10	MC74HC138AF	ADDRESS SELECTER	101	DTA144EK	LOCK DETECTION
11	T082CPS	SAMPLE PULSE AMP.	102	DTA144EK	LOCK DETECTION
12	TC74HC125AF	INTERNAL BUS DRIVER	103	DTA144EK	V SYNC SELECTION
13	MC74HC138AF	ADDRESS SELECTER	104	DTA144EK	V SYNC SELECTION
14	MC34051M	RS422 TRANSCEIVER	105	2SC2412K	BUFFER
15	MC74HC04F	INVERTER	106	2SA1037K	BUFFER
16	MC74HC123AF	SAMPLE PULSE GEN.	107	2SC2412K	BUFFER
17	TC74HC03AF	NAND (O. C.)	108	2SC2412K	BUFFER
19	TC74HC151AF	8 TO 1 SELECTER	109	2SA1037K	BUFFER
20	TC74HC151AF	8 TO 1 SELECTER	110	DTA144EK	INT. SIGNAL SW
21	TC74HC151AF	8 TO 1 SELECTER	111	2SC2412K	BUFFER
22	UPD71051GU-10	SERIAL CONTROL UNIT	112	2SC2412K	BUFFER
23	UPD71051GU-10	SERIAL CONTROL UNIT	113	2SC2412K	BUFFER
24	UPD71051GU-10	SERIAL CONTROL UNIT	114	DTA144EK	DU. SIGNAL SW
25	LTC485CS8	RS485 TRANSCEIVER	115	2SC2412K	BUFFER
26	LTC485CS8	RS485 TRANSCEIVER	116	DTA144EK	525/625 SW
27	MAX202CSE	RS232C TRANSCEIVER	151	2SC2412K	BUFFER
28	MAX202CSE	RS232C TRANSCEIVER	152	2SC2412K	BUFFER
30	SN74HC4040ANS	LINE COUNTER	153	2SC2412K	BUFFER
31	MC74HC04F	INVERTER	154	2SC2412K	BUFFER
32	SN74HC05ANS	INVERTER (O. C.)	155	2SA1037K	BUFFER
33	SN74HC05ANS	INVERTER (O. C.)			
34	MC74HC30F	8 INPUT NAND	D01	RD5.6S-B	PROTECTION
35	MC74HC541AF	OCTAL BUFFER	02	RD5.6S-B	PROTECTION
36	MAX202CSE	RS232C TRANSCEIVER	03	RD5.6S-B	PROTECTION
37	PQ12TZ5U	+12V REGULATOR	04	RD5.6S-B	PROTECTION
51	NJM79L05A	-5V REGULATOR	05	RD5.6S-B	PROTECTION
52	LM2940CT-5.0	+5V REGULATOR	12	RD6.2ES-B1	PROTECTION
101	BA7046F	SYNC SEPARATION	13	RD6.2SB	SAD BLANKING
102	CXA1727Q	ID-1 DETECTOR	29	RD6.2SB	PROTECTION
103	CXD2122AQ	ID-1 ENCODER	30	RD6.2SB	PROTECTION
105	CXD2343S	DOT CLOCK COUNTER	31	RD6.2SB	PROTECTION
106	MC74HC163AF	4 BIT COUNTER	32	RD6.2SB	PROTECTION
107	HN27C256-10	INTERNAL SIGNAL DATA	33	RD6.2SB	PROTECTION
108	HN27C256-10	INTERNAL SIGNAL DATA	34	RD6.2SB	PROTECTION
109	CXD1171M	D/A CONVERTER	35	RD6.2SB	PROTECTION
110	TC74HC166AF	P/S CONVERTER	36	RD6.2SB	PROTECTION
111	MC74HC4053F	ANALOG SW	37	RD6.2SB	PROTECTION
113	MC74HC74AF	SAD BLANKING	38	RD6.2SB	PROTECTION
114	TLC29321PW	PLL	39	RD6.2SB	PROTECTION
115	MC74HC10F	3 INPUT NAND	40	RD6.2SB	PROTECTION
116	MC74HC4053F	ANALOG SW	41	RD6.2SB	PROTECTION
117	MC74HC00AF	NAND	103	MAX110	INTERNAL SIGNAL Y SW
118	UPC393G2	OP. AMP	104	MAX110	INTERNAL SIGNAL Y OUT
119	MC74HC4053F	ANALOG SW	105	MAX110	INTERNAL SIGNAL PB/PR SW
120	CXD1030	SYNC GENERATOR	106	MAX110	INTERNAL SIGNAL PB OUT
121	MC74HC04F	INVERTER	107	MAX110	INTERNAL SIGNAL PR OUT
122	TC74HC04AF	INVERTER	108	MAX110	D. U. SIGNAL SW
123	MC74HC74AF	D FLIP FLOP	109	MAX110	D. U. SIGNAL OUT
124	Z8622812PSC	CLOSED CAPTION DISPLAY	111	MAX110	SAD RCH
125	SN74HC05ANS	INVERTER (O. C.)	112	MAX110	SAD GCH
126	CXD1132Q	VITC READER	113	MAX110	SAD BCH



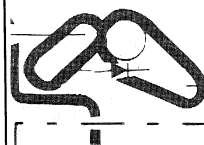
**E**

(DEFLECTION DRIVE, PULSE GENERATOR, SYSTEM CONTROL, H-V OUT)

— E BOARD — <Conductor Side>

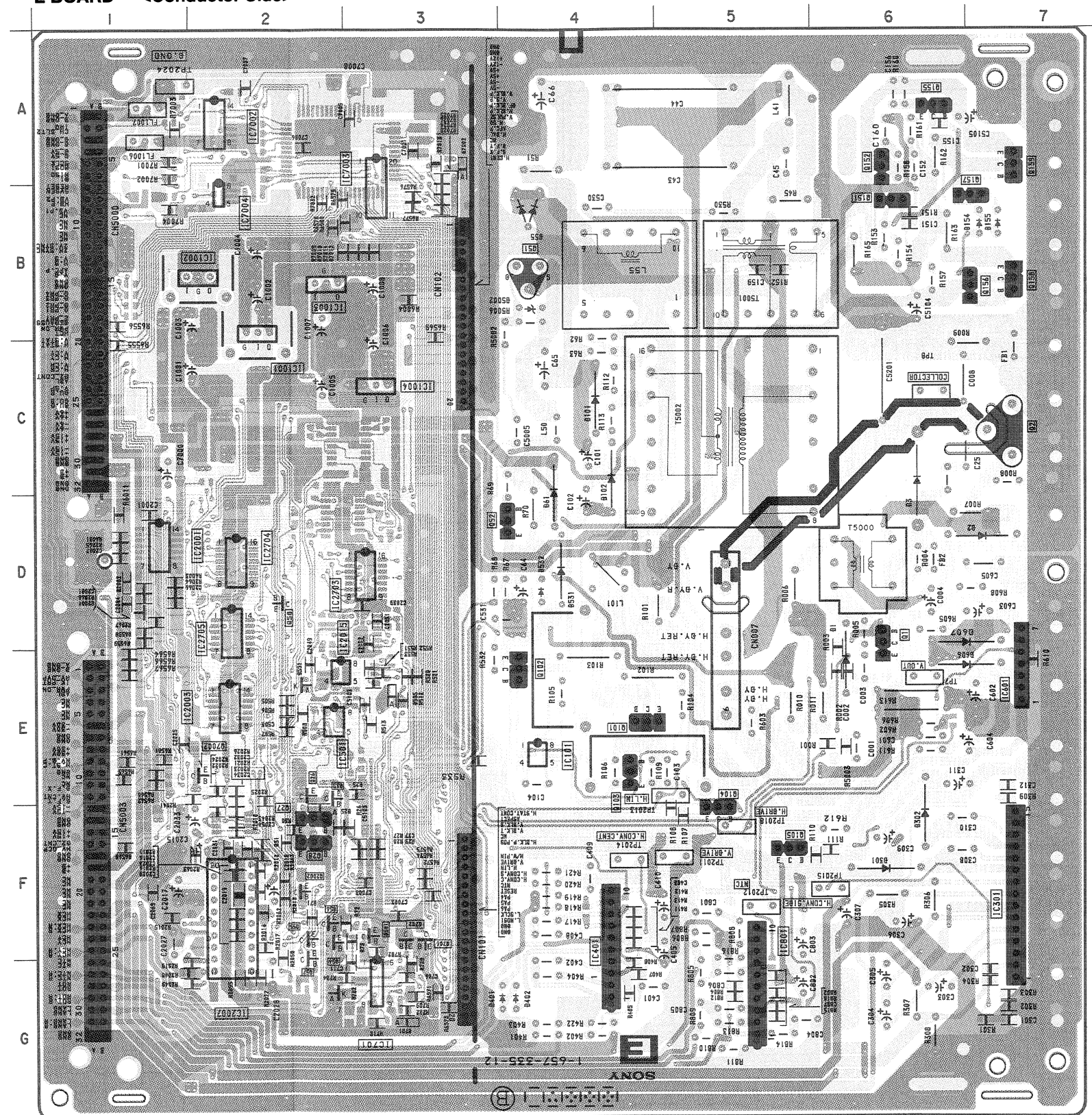
**E BOARD  
SEMICONDUCTOR LOCATION**

IC	Q702 F-3 Q2001 D-1 Q2002 F-2 Q2003 E-12 Q5000 E-12 Q7001 B-13 Q7002 E-2 Q7003 A-12
	DIODE
IC1004 C-3 IC2001 D-1 IC2002 D-13 IC2003 E-2 IC2007 F-2 IC2011 F-13 IC2012 D-12 IC2015 E-2 IC2016 D-12 IC2017 C-12	D1 E-6 D2 D-7 D25 F-2 D55 B-4 D61 D-4 D101 C-4 D102 C-4 D154 B-7 D155 B-7 D301 F-6
IC2019 E-13 IC2701 D-13 IC2702 D-12 IC2703 D-3 IC2704 D-2 IC2705 D-2 IC7001 A-12 IC7002 A-2 IC7003 A-3 IC7004 B-2	D302 F-6 D401 G-4 D402 G-4 D502 E-12 D503 E-12 D505 E-3 D531 D-4 D532 D-4 D551 E-2 D606 E-6
IC7005 F-12	D607 D-7 D701 G-3 D702 G-2 D5001 E-12 D5002 B-4 D7001 A-13 D7002 A-3
TRANSISTOR	TEST POINT
Q1 D-6 Q2 C-7 Q25 E-2 Q26 E-2 Q27 F-2 Q28 F-2 Q51 B-4 Q52 D-4 Q54 F-2 Q55 F-2	TP1 G-12 TP3 B-13 TP4 B-12 TP5 B-12 TP6 C-13 TP7 E-6 TP8 C-6 TP9 C-12 TP2001 E-13 TP2005 F-13
Q56 F-2 Q57 G-2 Q58 D-2 Q101 E-4 Q102 E-4 Q103 E-4 Q104 F-5 Q105 F-5 Q151 B-6 Q152 A-6	TP2007 C-12 TP2008 E-13 TP2010 C-12 TP2011 F-5 TP2012 F-5 TP2013 E-5 TP2014 F-4 TP2015 F-6 TP2016 G-13 TP2017 F-13
Q155 A-6 Q156 B-7 Q157 B-7 Q158 B-7 Q159 A-7 Q501 F-3 Q502 E-12 Q505 E-13 Q507 E-12 Q701 F-3	TP2018 F-5 TP2023 F-14 TP2024 A-1 TP2025 D-12

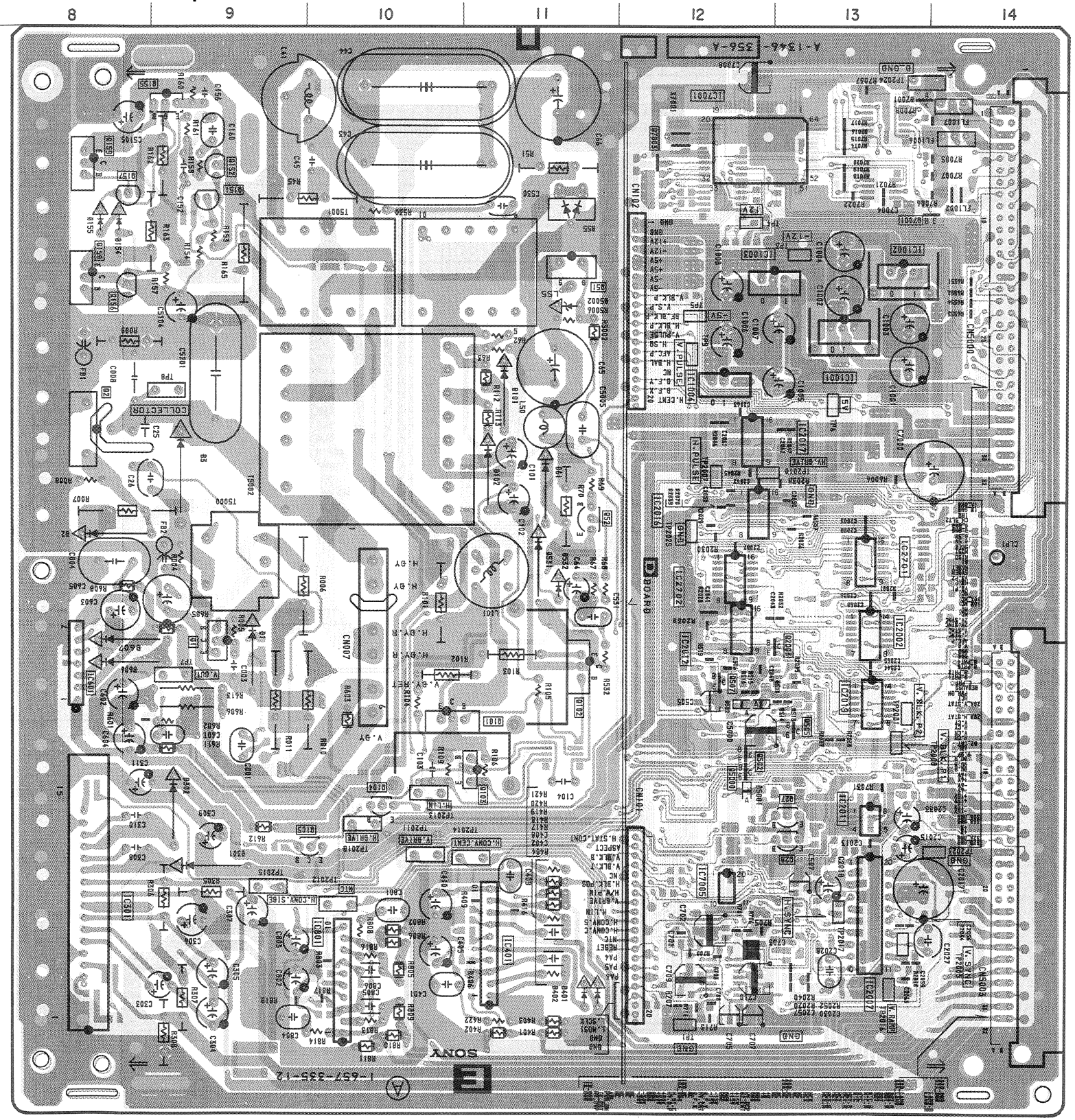


**NOTE:**

The circuit indicated as left contains high voltage of over 600 Vp-p. Care must be paid to prevent an electric shock in inspection or repairing.



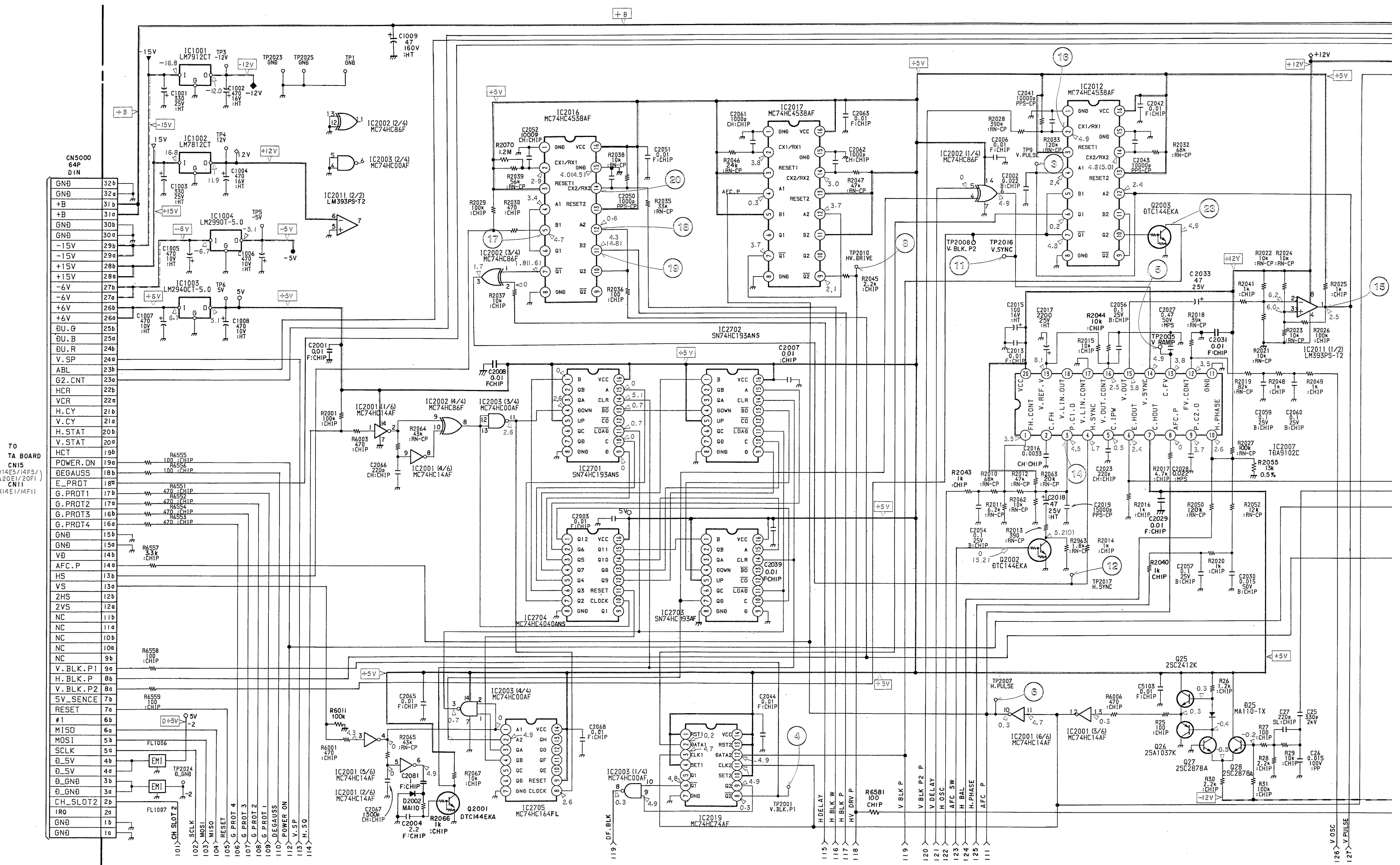
— E BOARD — <Component Side>



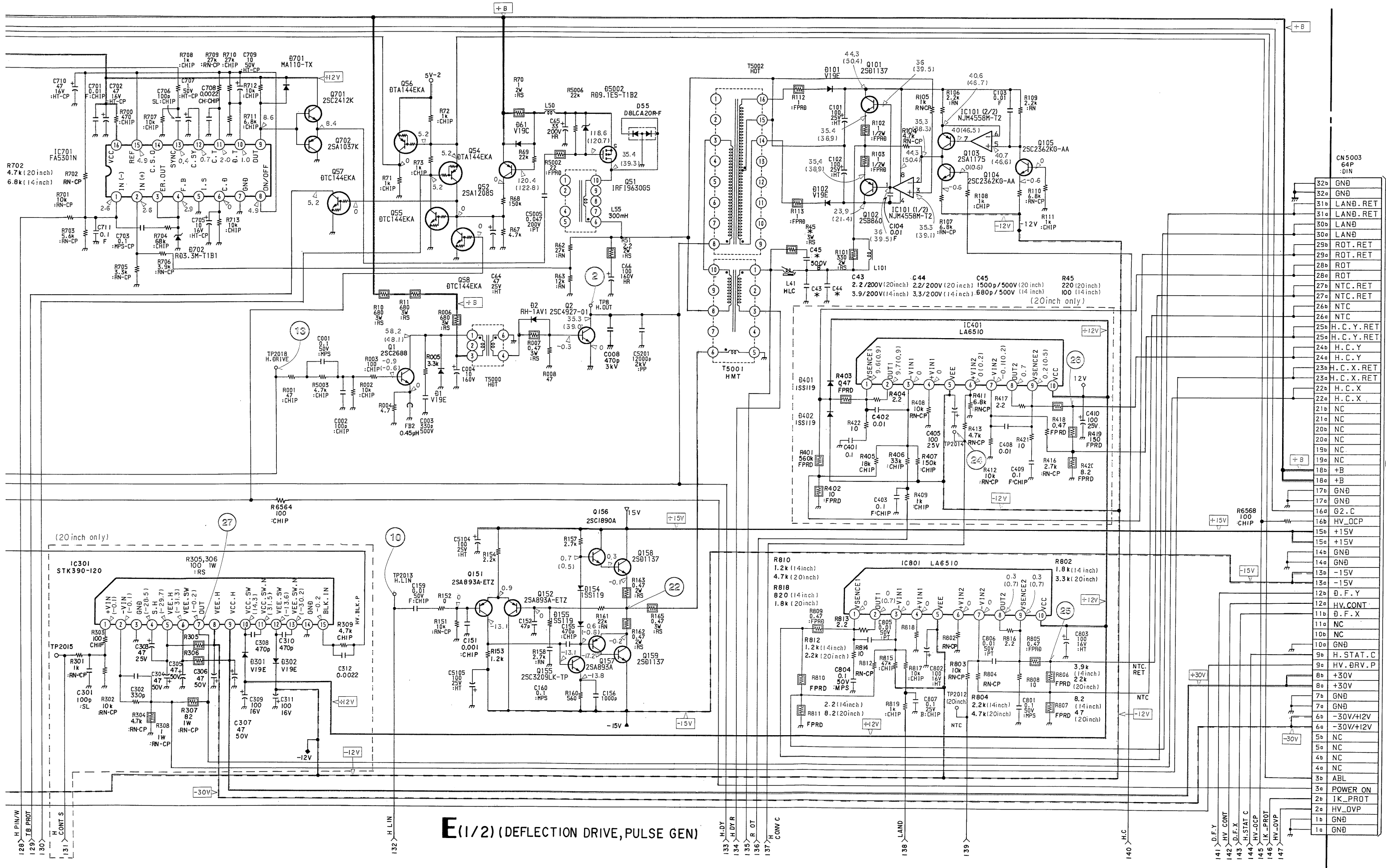


E (DEFLECTION DRIVE, PULSE GEN) BOARD (1/2)

- Refer to page 5-46 for Function of Semiconductor
- Refer to page 5-46 for Waveforms







E(1/2) (DEFLECTION DRIVE, PULSE GEN)

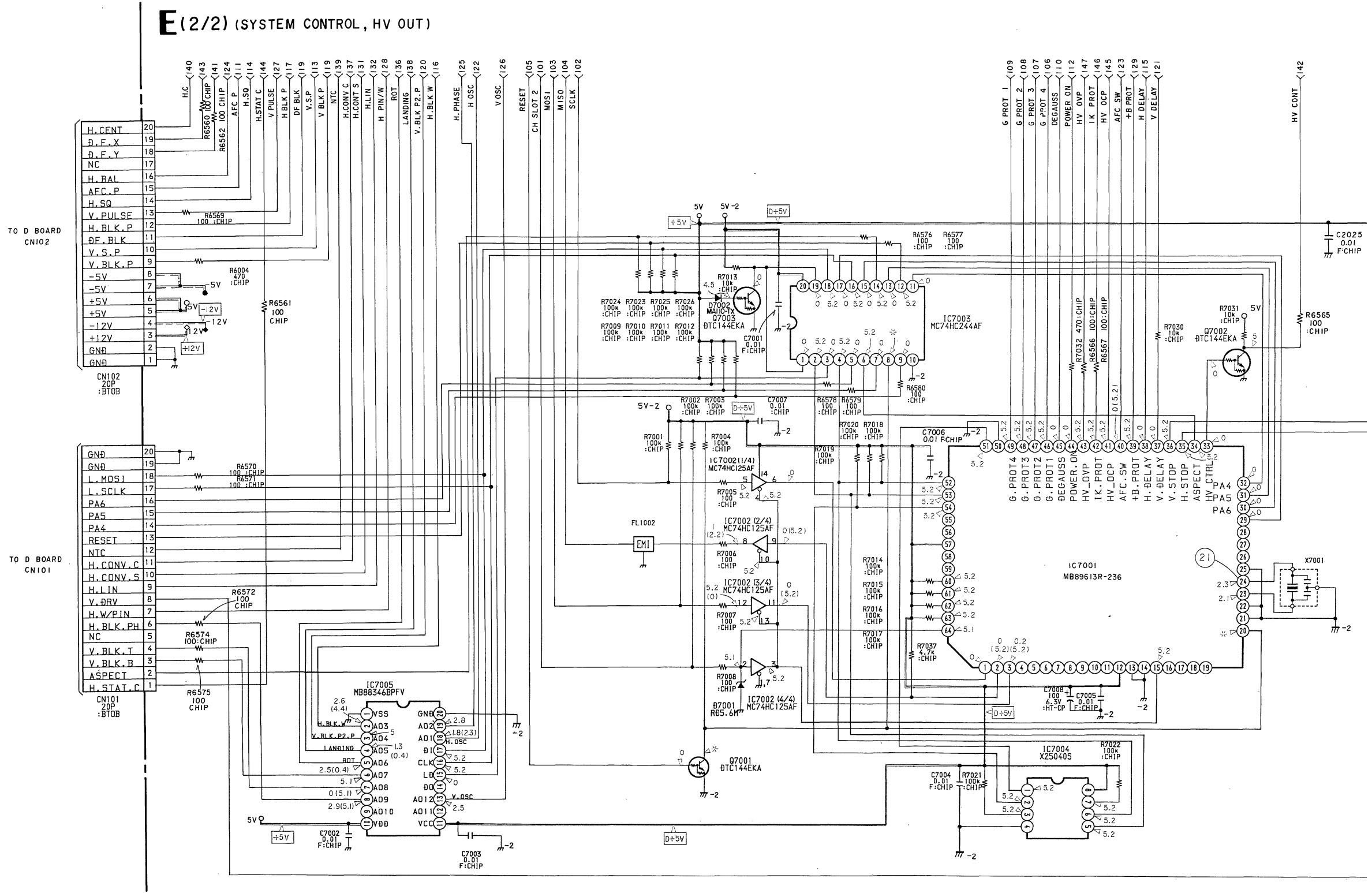
32b	GND
32a	GND
31b	LAND.RET
31a	LAND.RET
30b	LAND
30a	LAND
29b	ROT.RET
29a	ROT.RET
28b	ROT
28a	ROT
27b	NTC.RET
27a	NTC.RET
26b	NTC
26a	NTC
25b	H.C.Y.RET
25a	H.C.Y.RET
24b	H.C.Y
24a	H.C.Y
23b	H.C.X.RET
23a	H.C.X.RET
22b	H.C.X
22a	H.C.X
21b	NC
21a	NC
20b	NC
20a	NC
19b	NC
19a	NC
18b	+B
18a	+B
17b	GND
17a	GND
16a	G2.C
16b	HV_OCP
15b	+15V
15a	+15V
14b	GND
14a	GND
13b	-15V
13a	-15V
12b	D.F.Y
12a	HV_CONT
11b	D.F.X
11a	NC
10b	NC
10a	NC
9b	H.STAT.C
9a	HV.DRV.P
8b	+30V
8a	+30V
7b	GND
7a	GND
6b	-30V/H2V
6a	-30V/H2V
5b	NC
5a	NC
4b	NC
4a	NC
3b	ABL
3a	POWER ON
2b	IK_PROT
2a	HV_OVP
1b	GND
1a	GND

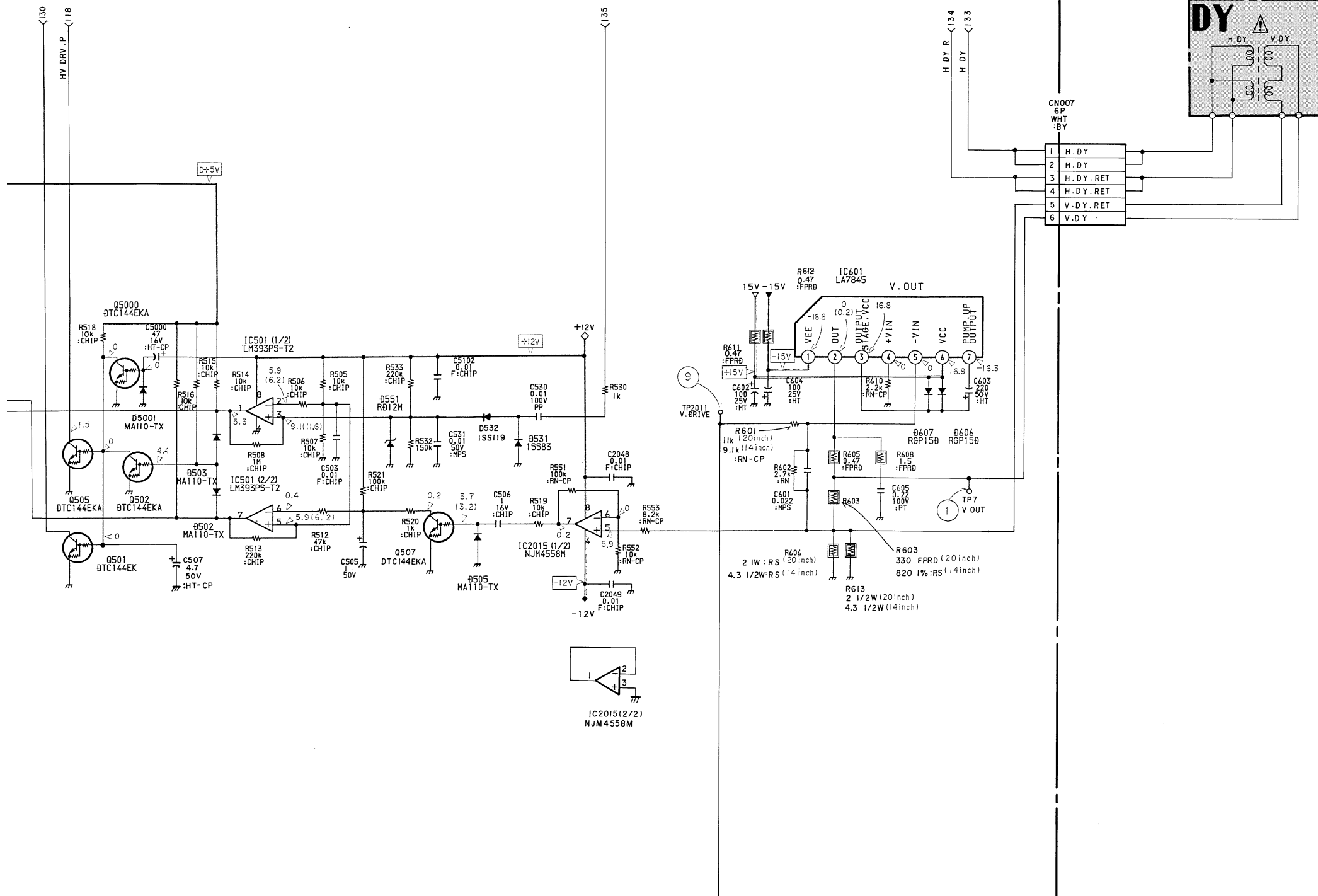
TO TA BOARD  
 CN18  
 (14E5/14F5/1)  
 (20E1/20F1)  
 CN15  
 (14E1/14F1)

E (SYSTEM CONTROL, H-V OUT) BOARD (2/2)

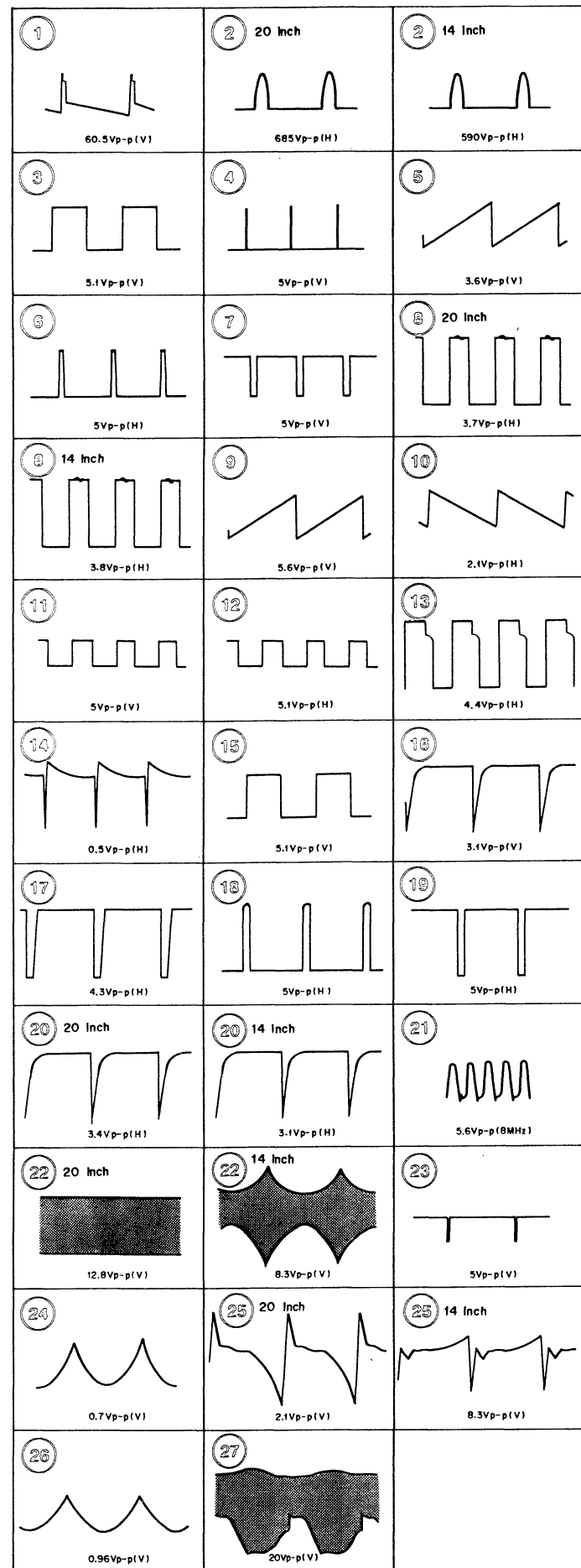
Refer to page 5-40 for Printed Wiring Board

E (2/2) (SYSTEM CONTROL, HV OUT)





• E BOARD Waveforms



E E

E BOARD

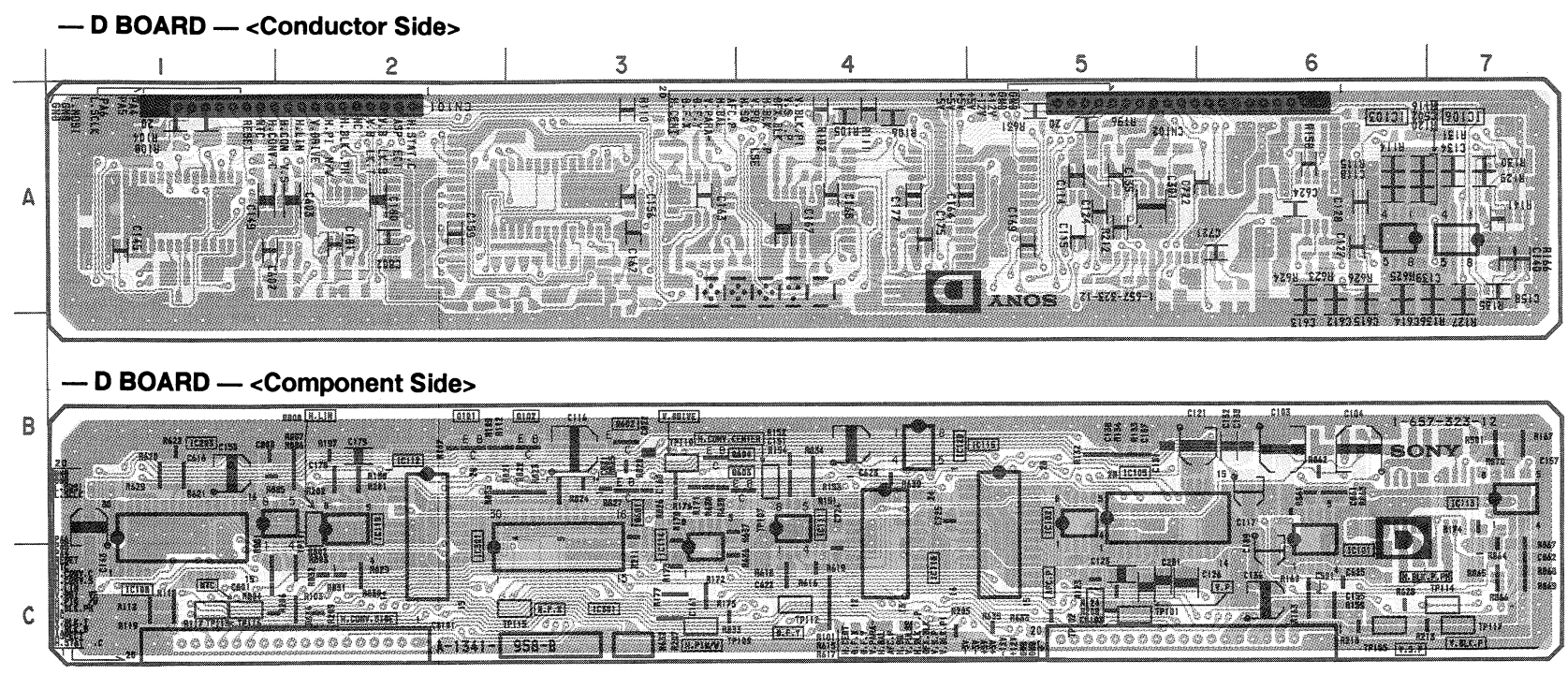
Function of Semiconductor

IC101	NJM4558M	H CENTER AMP	Q151	2SA893A	H LIN AMP
301	STK390-120	H CONVERGENCE	152	2SA893A	CLAMP
401	LA6510	ROTATION, H. CONV. CENTER	155	2SC3209LK	LEVEL SW
501	LM393PS	H/V STOP COMPARATOR	156	2SC1890A	H LIN AMP
601	LA7845	V OUT	157	2SA893A	H LIN AMP
701	FA5301N-TE1	PWM CONTROL	158	2SD1137	H LIN OUT
801	LA6510	LANDING, NTC	159	2SD1137	H LIN OUT
1001	LM7912CT	-12V REG	501	DTC144EKA	DEF STOP PROT DRIVE
1002	LM7812CT	+12V REG	502	DTC144EKA	INVERTER
1003	LM2940CT-5.0	+5V REG	505	DTC144EKA	DEF STOP PROTECTOR
1004	LM2990T-5.0	-5V REG	507	DTC144EKA	DISCHARGE SW
2001	MC74HC14AF	INVERTER	701	2SC2412K-OR	PWM DRIVE
2002	MC74HC86F	V DELAY SW	702	2SA1037K-OR	PWM DRIVE
2003	MC74HC00AF	DF PULSE GEN	2001	DTC144EKA	INVERTER
2007	TDA9102C	V OSC, H OSC, AFC	2002	DTC144EKA	AFC SW
2011	LM393PS	V PULSE GEN	2003	DTC144EKA	V BLK PULSE SW
2012	MC74HC4538AF	V BLK P2 GEN	5000	DTC144EKA	POWER ON RESET
2015	NJM4558M	V STOP PROT	7001	DTC144EKA	RESET SW
2016	MC74HC4538AF	H BLK GEN, DELAY	7002	DTC144EKA	INVERTER
2017	MC74HC4538AF	H/V DRIVE PULSE GEN	7003	DTC144EKA	ASV SW
2019	MC74HC74AF	V BLK PULSE GEN			
2701	SN74HC193ANS	V COUNTER	D1	V19E-T52	PROTECT
2702	SN74HC193ANS	V COUNTER	2	RH-1AV1	DAMPER
2703	SN74HC193ANS	V COUNTER	25	MA110-TX	DAMPER
2704	MC74HC4040AF	V COUNTER	55	DBLCA20R-F	DAMPER
2705	MC74HC164F	V. START	61	V19C-T52	SWITCH
7001	MB89613PF-SUB02	SUB MICROCOMPUTER	101	V19C-T52	H CENT
7002	MC74HC125AF	BUFFER	102	V19C-T52	H CENT
7003	MC74HC244AF	BUFFER	154	1SS119	PROTECTOR
7004	X25040S-C7000	EEP ROM	155	1SS119	PROTECTOR
7005	MB88346BPFV-EF	12CH DAC	301	V19E-T52	VCC SW
			302	V19E-T52	VEE SW
Q1	2SD1138-C	H DRIVE	401	1SS119	SWITCH
2	2SC4927-01	H OUT	402	1SS119	SWITCH
25	2SC2412K-OR	AFC PULSE	502	MA110-TX	SWITCH
26	2SA1037K-OR	AFC PULSE	503	MA110-TX	SWITCH
27	2SC2878A	AFC PULSE	505	MA110-TX	PROTECTOR
28	2SC2878A	AFC PULSE	531	1SS83TA	PROTECTOR
51	IRF19630GS-LF	PWM	532	1SS119	PROTECTOR
52	2SA1208S	H WIDTH AMP	551	RD12M-B1	PROTECTOR
54	DTA144EKA	LATCH	606	RGP15DPKG23	PUMP UP
55	DTC144EKA	H WIDTH SW	607	RGP15DPKG23	PUMP UP
56	DTA144EKA	LATCH	701	MA110-TX	SWITCH
57	DTC144EKA	DRIVE	702	RD3.3M-B1	PROTECTOR
58	DTC144EKA	POWER RECET	2002	MA110-TX	PROTECTOR
101	2SD1137	H CENT AMP	5001	MA110-TX	PROTECTOR
102	2SB860	H CENT AMP	5002	RD9.1ES-B2	PROTECTOR
103	2SA1175-HFE	BIAS	7001	RD5.6M-B	DC LEVEL SHIFT
104	2SC2362KG-AA	H CENT AMP	7002	MA110-TX	SWITCH
105	2SC2362KG-AA	BIAS			

**D** (H•DEFLECTION DRIVE)

**D BOARD**  
SEMICONDUCTOR LOCATION

IC	
IC101	B-6
IC102	B-5
IC103	A-6
IC105	B-5
IC106	A-7
IC108	B-1
IC111	B-4
IC112	B-2
IC113	B-7
IC114	C-3
IC115	B-5
IC118	C-4
IC119	B-2
IC120	B-4
IC203	B-1
IC301	C-3
TRANSISTOR	
Q101	B-2
Q102	B-3
Q601	B-3
Q602	B-3
Q603	B-4
Q604	B-3
DIODE	
TP101	C-5
TP102	C-5
TP105	C-6
TP107	B-4
TP109	C-3
TP110	B-3
TP111	B-2
TP112	C-4
TP113	C-1
TP114	C-7
TP115	C-3
TP116	C-1
TP117	C-7

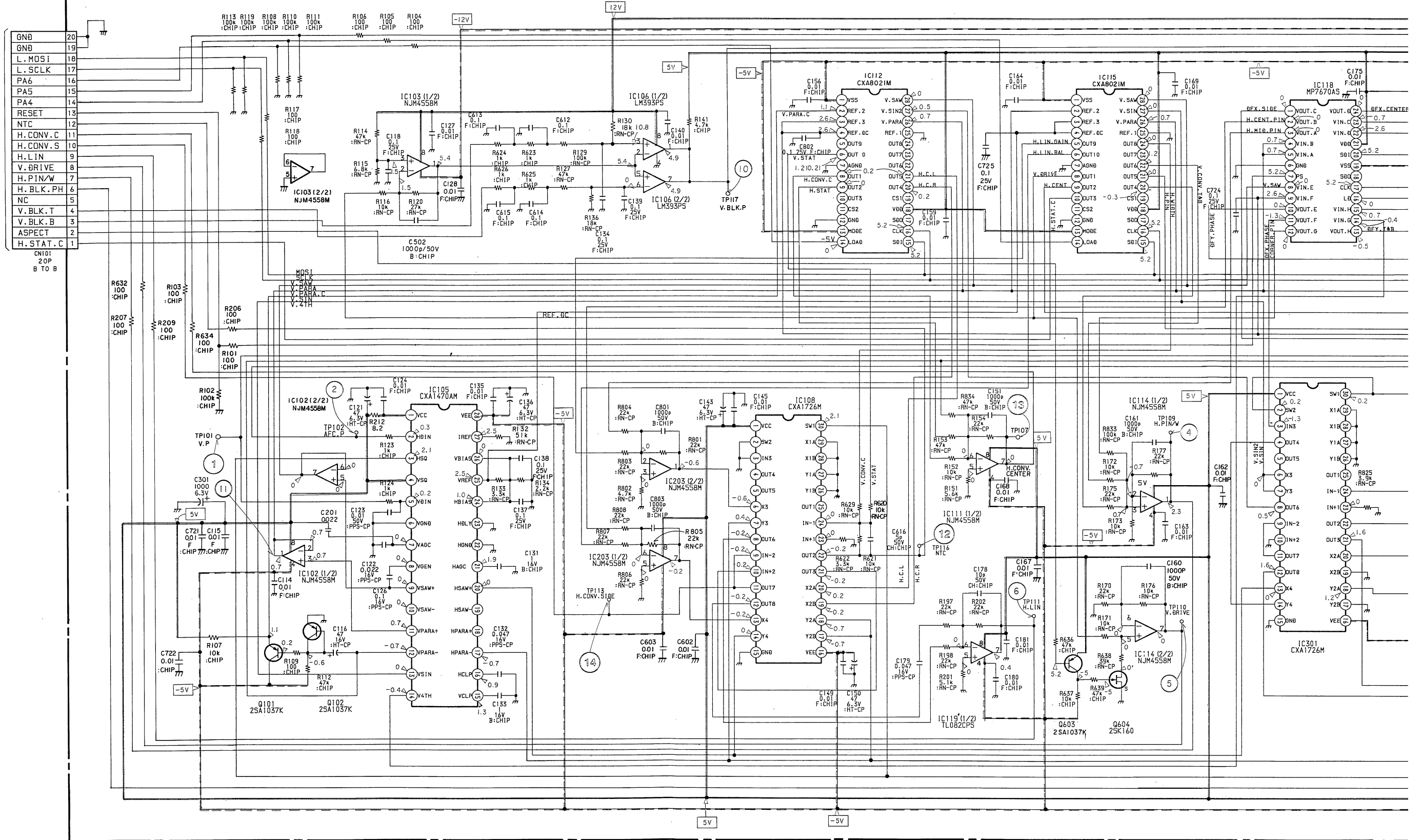


• D (H-DEFLECTION DRIVE) BOARD

D D

D (H.DEFLECTION)

TO E BOARD  
CN101



A

B

C

D

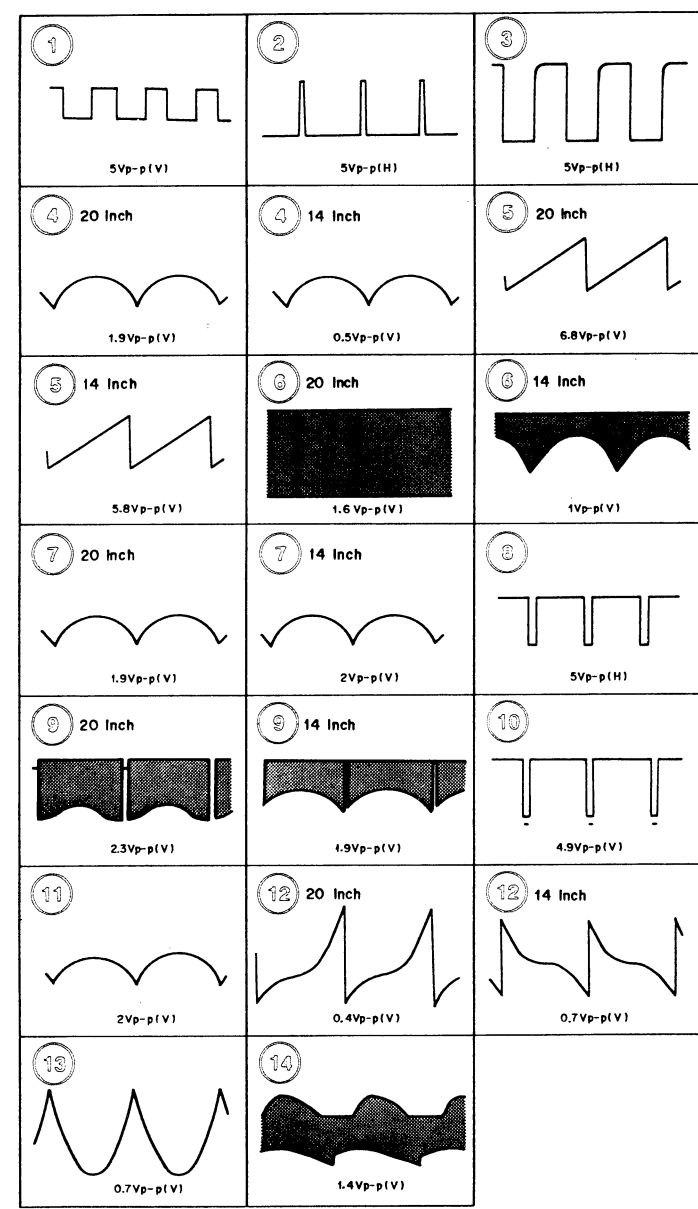
E

F

G

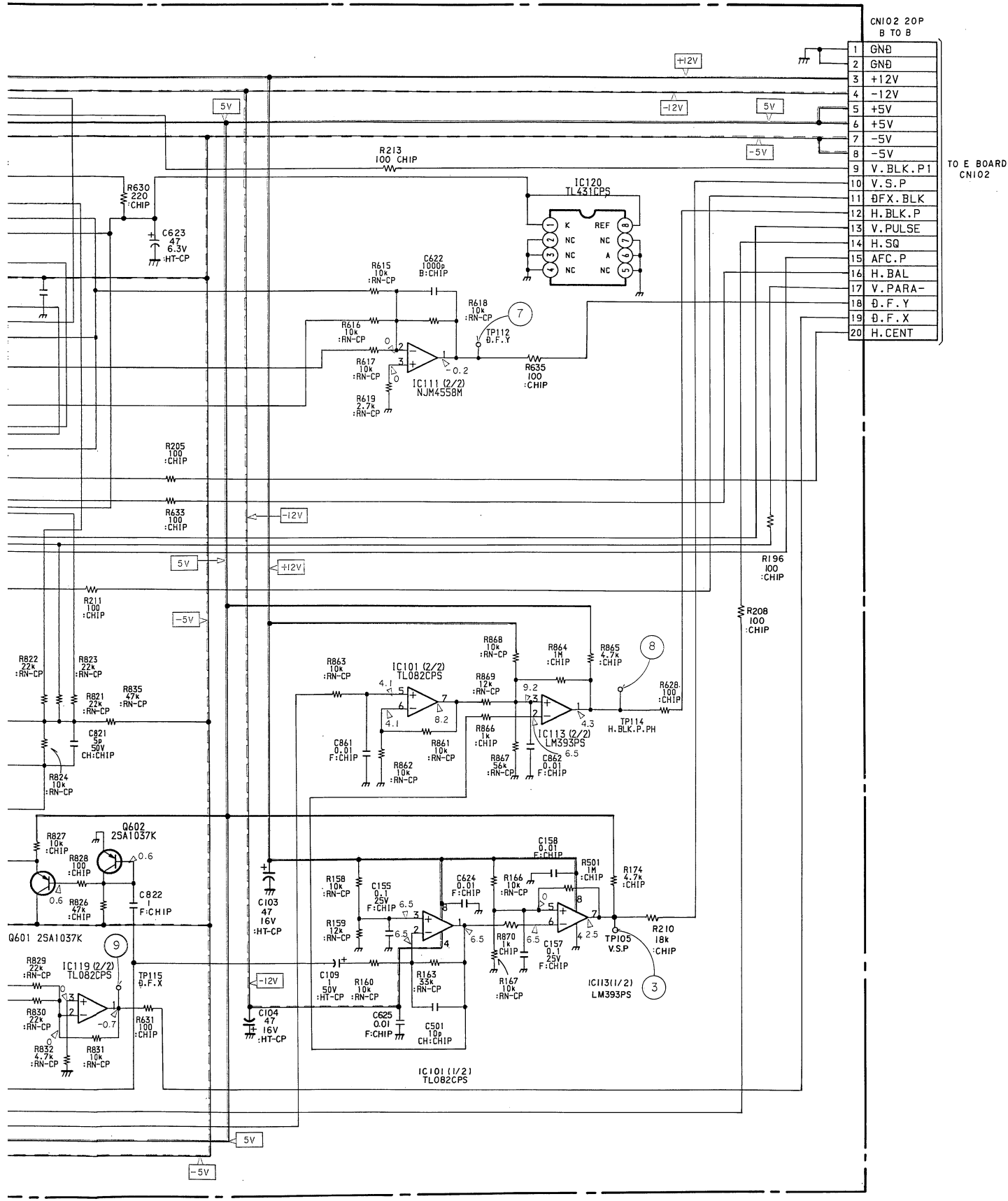
H

• D BOARD Waveforms



D BOARD  
Function of Semiconductor

IC101	TL082CPS-E20	H. BLK. PHASE, VSP GEN
102	NJM4558M	BUFFER
103	NJM4558M	V. BLK GENERATOR
105	CXA1470AM	SIGNAL GENERATOR
106	LM393PS	V. BLK GENERATOR
108	CXA1726M	H. LIN., CONVER., SIDE MOD
111	NJM4558M	H. CONV. CENTER, D.F.Y GEN
112	CXA8021M	H. CONVER GENERATOR
113	LM393PS	H. BLK. PHASE, V.S.P GEN
114	NJM4558M	V. DRIVE, H. PIN WIDTH GEN
115	CXA8021M	DEFLECTION GEN.
118	MP7670AS	8CH DAC
119	TL082CPS-E20	H. PARA. CLAM, LIN GEN
120	TL431CPS-E05	+2.5V REG
203	NJM4558M	H. LIN. GENERATOR
301	CXA1726M	DFX MOD
Q101	2SA1037K-QR	V PARA CLAMP
102	2SA1037K-QR	V PARA CLAMP
601	2SA1037K-QR	H PARA CLAMP
602	2SA1037K-QR	H PARA CLAMP
603	2SA1037K-QR	ASPECT SWITCH
604	2SK160	ASPECT SWITCH





• PA (HIGH VOLTAGE SUPPLY), PC (F.B.T), C (CRT SOCKET) BOARD

PA BOARD

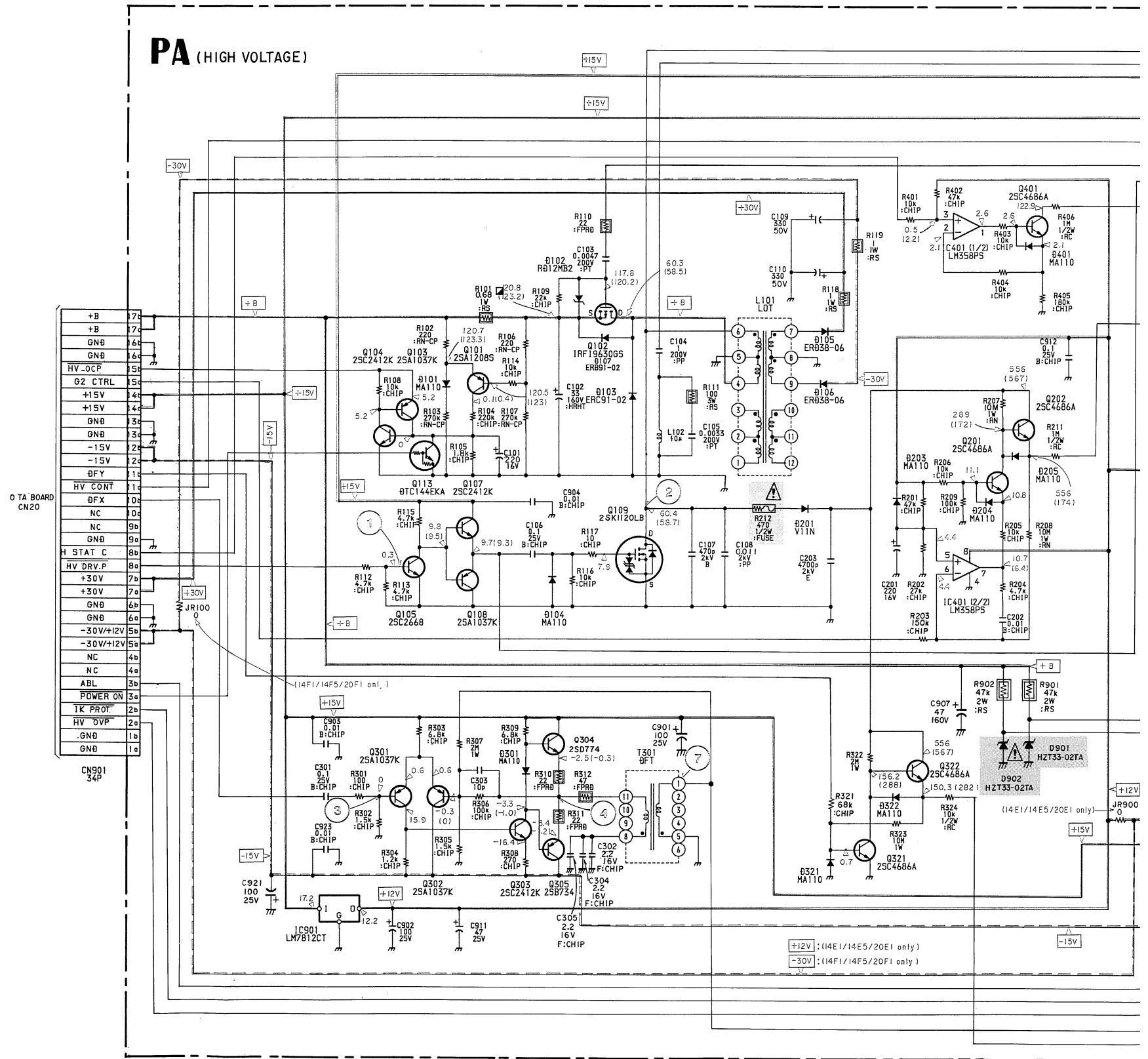
Function of Semiconductor

IC401	LM358PS-T5L	G2/H STAT CONTROL	D103	ERC91-02TP11	FLYWHEEL
501	FA5301N-TE1	PWM CONTROL	104	MA110-TX	CLAMP
502	LM393PS-T5L	DISCHARGE	105	ERD38-06TP11	+30V RECT
801	LM358PS-T5L	BUFFER	106	ERD38-06TP11	-30V RECT
901	LM7812CT	+12V REG	107	ERB91-02TP1	PROTECTOR
			201	V11N	+500V RECT
Q101	2SA1208S	HV REG OCP DET	203	MA110-TX	DISCHARGE
102	1RF19630GS	HV REG SWITCHING	204	MA110-TX	PROTECTOR
103	2SA1037K-0	LATCH	205	MA110-TX	PROTECTOR
104	2SC2412K-0	LATCH	301	MA110-TX	BIAS
105	2SC2668-0TP	AMP	321	MA110-TX	PROTECTOR
107	2SC2412K-0	BUFFER	322	MA110-TX	PROTECTOR
108	2SA1037K-0	BUFFER	401	MA110-TX	PROTECTOR
109	1RFP650LF	HV OUT SWITCHING	501	MA110-TX	SWITCH
111	2SC2412K-0	BUFFER	502	MA110-TX	SWITCH
112	2SA1037K-0	BUFFER	505	MA110-TX	THERMAL COMP
113	DTC144EKA	PWR OFF RESET	511	MA110-TX	DISCHARGE
201	2SC4686A	G2 AMP	512	MA110-TX	SWITCH
202	2SC4686A	G2 BUFFER	513	RD3.0M-B	LIMITER
301	2SA1037K-0	DFX AMP	514	MA110-TX	SWITCH
302	2SA1037K-0	DFX AMP	516	MA110-TX	DISCHARGE
303	2SC2412K-0	DFX AMP	517	RD3.0M-B	LIMITER
304	2SD774-34	DFX DRIVER	518	MA110-TX	SWITCH
305	2SB734-34	DFX DRIVER	519	MA110-TX	SWITCH
321	2SC4686A	DFY AMP	521	MA110-TX	SWITCH
322	2SC4686A	DFY BUFFER	801	RD12M-B2	PROTECTOR
401	2SC4686A	H STAT OUT	802	MA110-TX	HV PROT RECT
D101	MA110-TX	THERMAL COMP	901	HZT33-02TA	1K PROT REF
102	RD12M-B2	PROTECT	902	HZT33-02TA	HV PROT REF

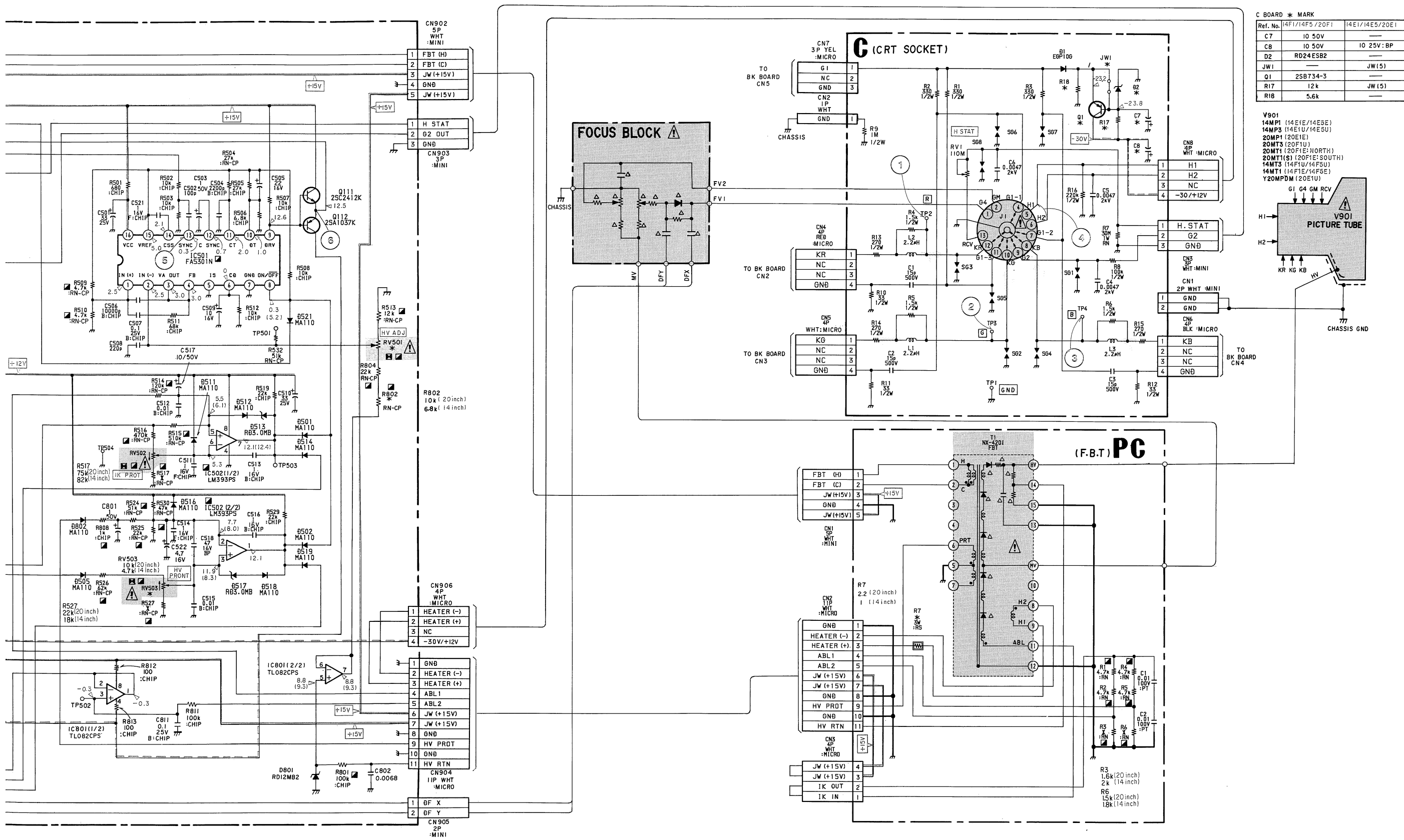
C BOARD

Function of Semiconductor

Q1	2SB734-3	G1 BIAS
D1	EGP10GPKG23	BLANKING CLAMP
2	RD24ES-B2	G1 BIAS

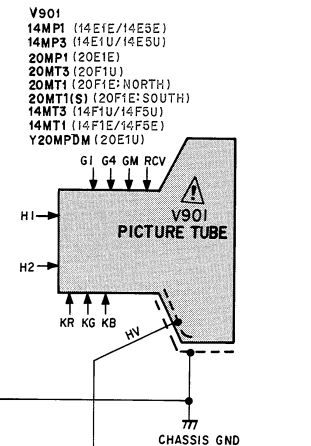






C BOARD \* MARK

Ref. No.	14F1/14F5/20F1	14E1/14E5/20E1
C7	10 50V	—
C8	10 50V	10 25V:BP
D2	RD24ESB2	—
JW1	—	JW(5)
Q1	2SB734-3	—
R17	12k	JW(5)
R18	5.6k	—



**PA** (HIGH VOLTAGE SUPPLY)

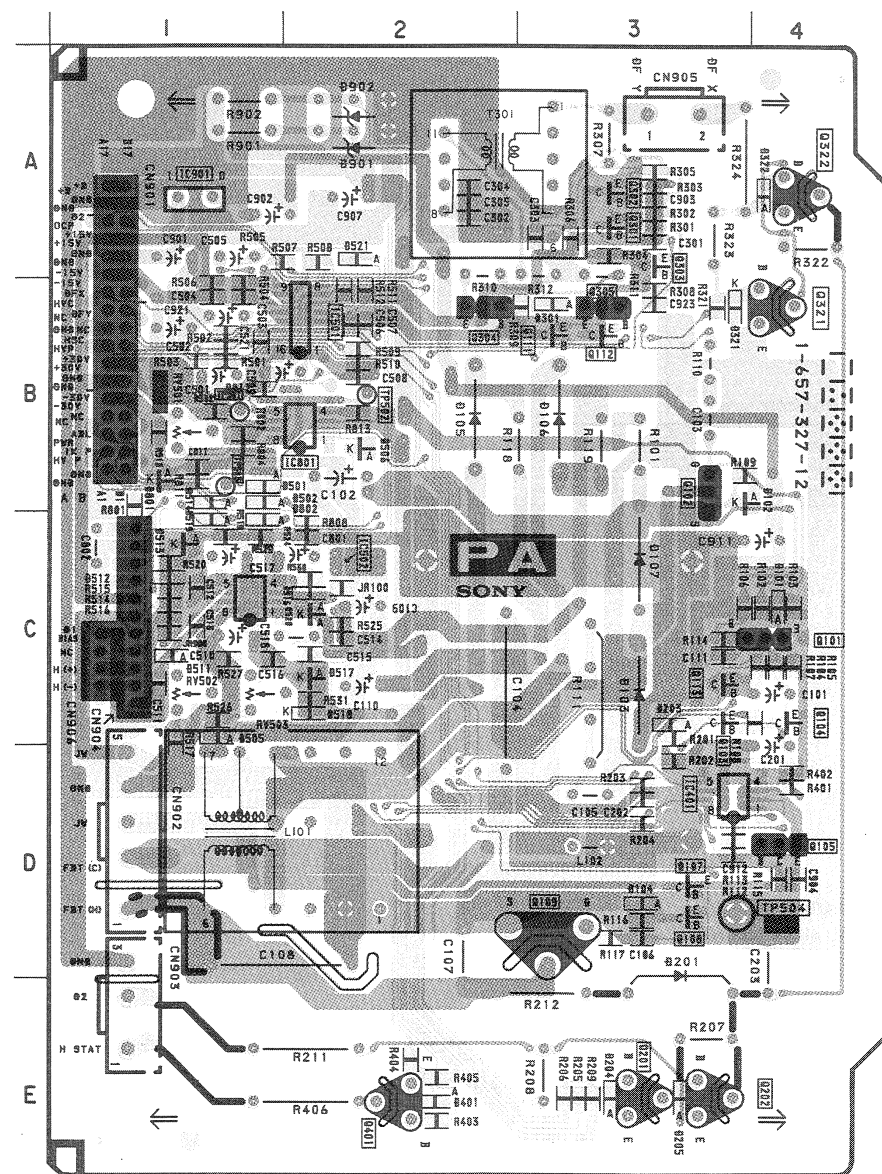
**PC** (F.B.T)

**C** (CRT SOCKET)

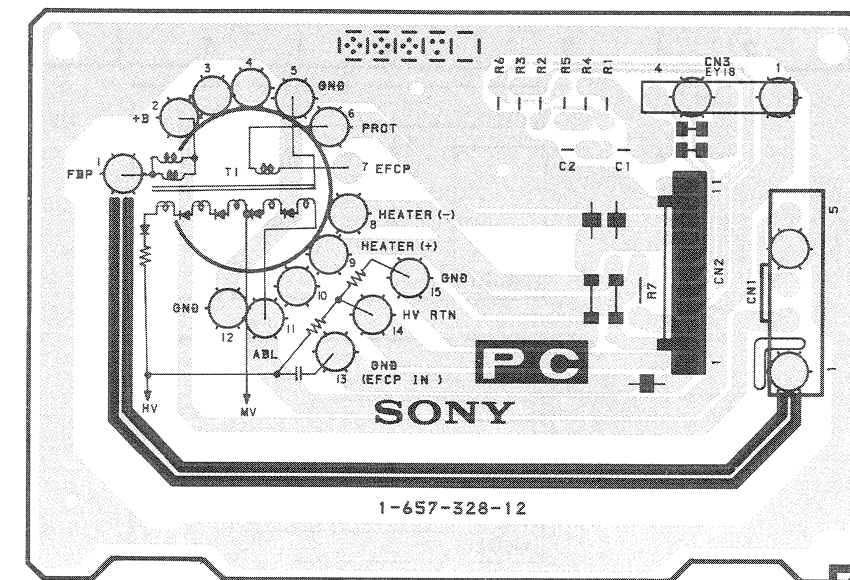
**PA BOARD SEMICONDUCTOR LOCATION**

IC	D107 C-3	D201 D-3	D203 C-3	D204 E-3
IC401	D-3	D205 E-3	D301 B-3	D321 B-3
IC501	B-2	D322 A-4	D401 E-2	D501 B-1
IC502	C-1	D502 B-1	D505 C-1	D511 C-1
IC801	B-2	D512 C-1	D513 C-1	D514 B-1
IC901	A-1	D517 C-1	D518 C-2	D519 C-1
<b>TRANSISTOR</b>				
Q101	C-4	D521 A-2	D801 B-1	D802 C-1
Q102	B-3	D801 B-1	D802 C-1	D901 A-2
Q103	C-3	D902 A-2	<b>VARIABLE RESISTOR</b>	
Q104	C-4	RV501 B-1	RV502 C-1	RV503 C-1
Q105	D-4	RV502 C-1	RV503 C-1	
Q107	D-3	RV503 C-1		
Q108	D-3			
Q109	D-3			
Q111	B-3			
Q112	B-3			
Q113	C-3			
Q201	E-3			
Q202	E-3			
Q301	A-3			
Q302	A-3			
Q303	A-3			
Q304	B-2			
Q305	B-3			
Q321	B-4			
Q322	A-4			
Q401	E-2			
<b>DIODE</b>				
D101	C-4	<b>TEST POINT</b>		
D102	B-4	TP501	B-1	
D103	C-3	TP502	B-1	
D104	D-3	TP503	B-1	
D105	B-2	TP504	D-3	
D106	B-3			

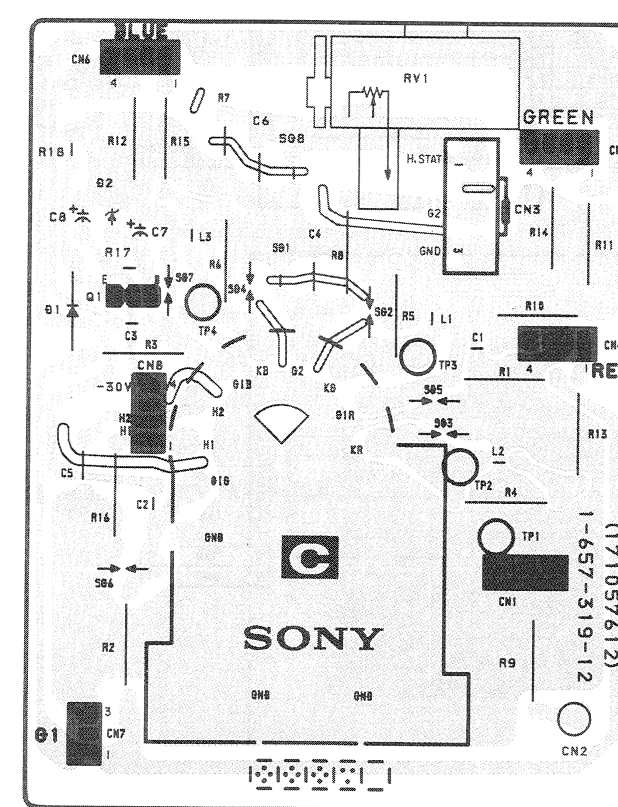
— PA BOARD — <Conductor Side>



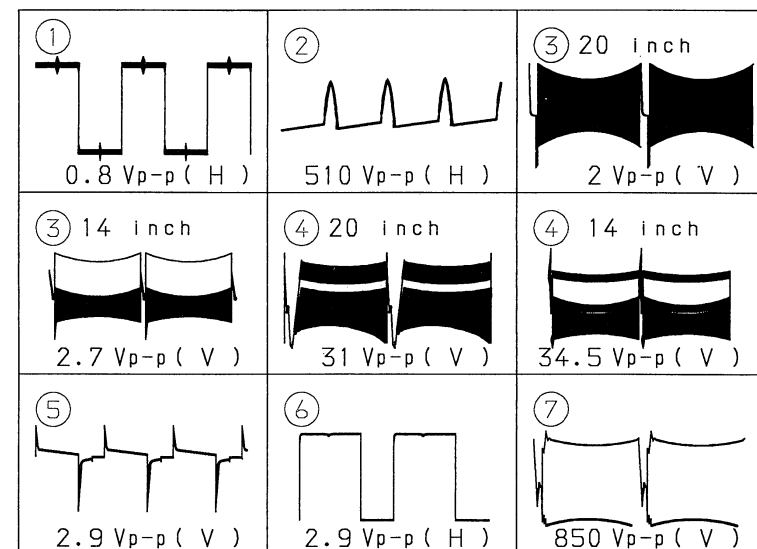
— PC BOARD — <Conductor Side>



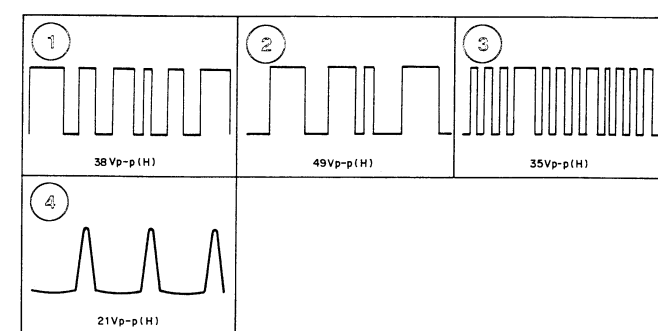
— C BOARD — <Conductor Side>



• PA BOARD Waveforms

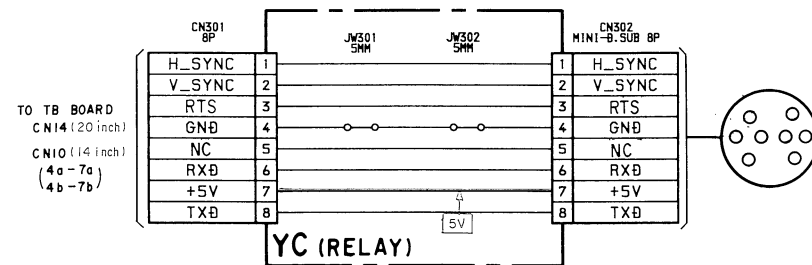
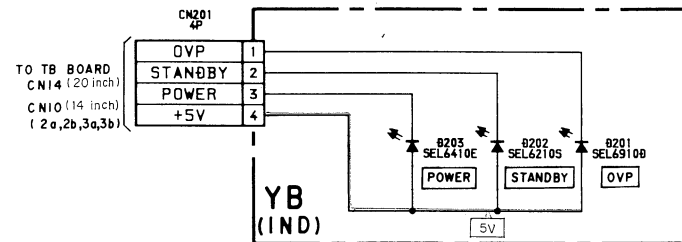
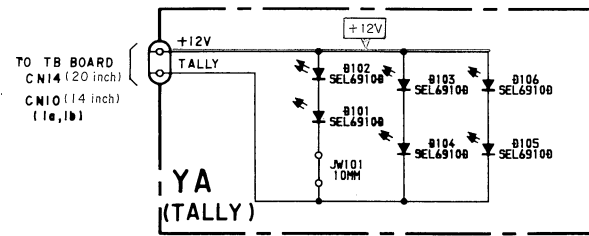


• C BOARD Waveforms

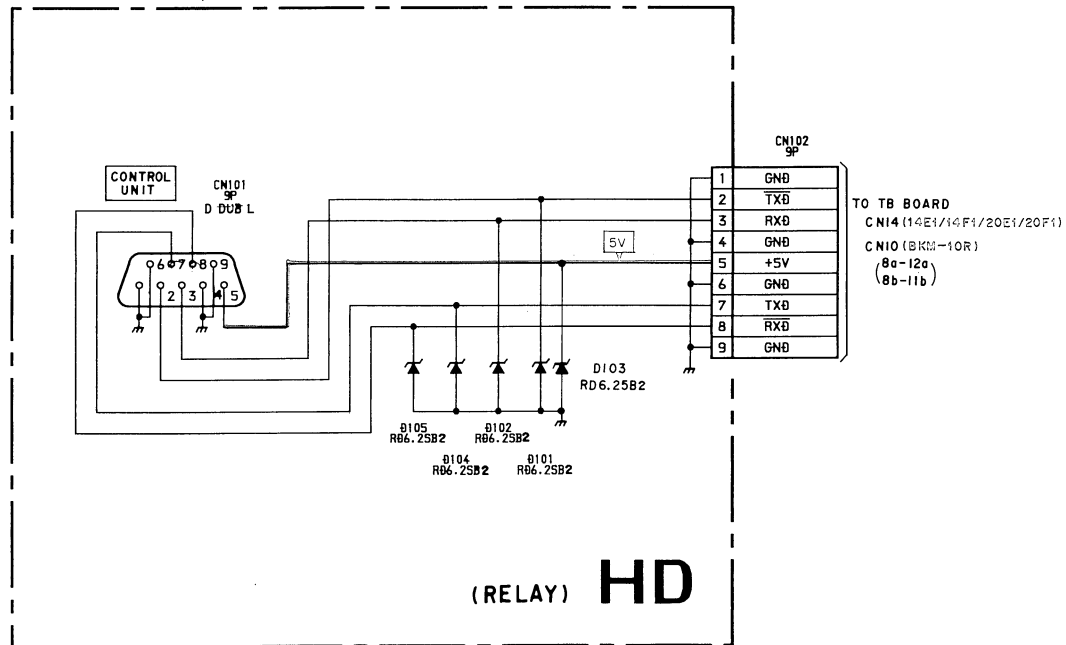


**NOTE:**  
The circuit indicated as left contains high voltage of over 600 Vp-p. Care must be paid to prevent an electric shock in inspection or repairing.

- YA (TALLY), YB (INDICATOR), YC (RELAY) BOARD
- HD (RELAY) BOARD (BVM-14E1E/14E1U/14F1E/14F1U/20E1E/20E1U/20F1E/20F1U, BKM-10R)



14E1/14F1/20E1/20F1, BKM-10R



**YA BOARD**

Function of Semiconductor

D101	SEL6910D-D	TALLY LAMP
102	SEL6910D-D	TALLY LAMP
103	SEL6910D-D	TALLY LAMP
104	SEL6910D-D	TALLY LAMP
105	SEL6910D-D	TALLY LAMP
106	SEL6910D-D	TALLY LAMP

**YB BOARD**

Function of Semiconductor

D201	SEL6910D-D	OVERLOAD INDICATOR
202	SEL6910D-D	STANDBY INDICATOR
203	SEL6910D-D	POWER INDICATOR

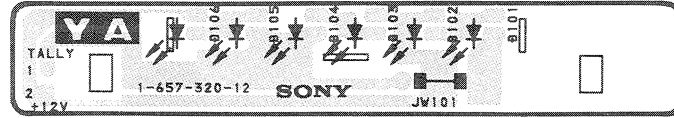
**HD BOARD**

Function of Semiconductor

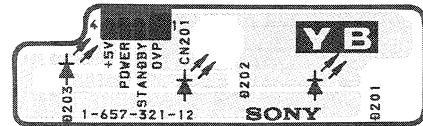
D101	RD6.25B2	PROTECTOR
102	RD6.25B2	PROTECTOR
103	RD6.25B2	PROTECTOR
104	RD6.25B2	PROTECTOR
105	RD6.25B2	PROTECTOR

**YA** (TALLY)   **YB** (INDICATOR)   **YC** (RELAY)   **HD** (RELAY)  
 (BVM-14E1E/14E1U/14F1E/14F1U/20E1E/20E1U/  
 20F1E/20F1U, BKM-10R)

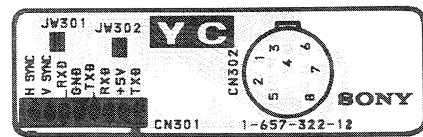
— YA BOARD — <Conductor Side>



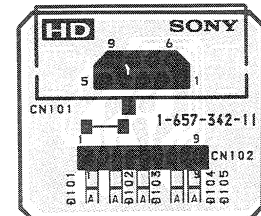
— YB BOARD — <Conductor Side>



— YC BOARD — <Conductor Side>



— HD BOARD — <Conductor Side>

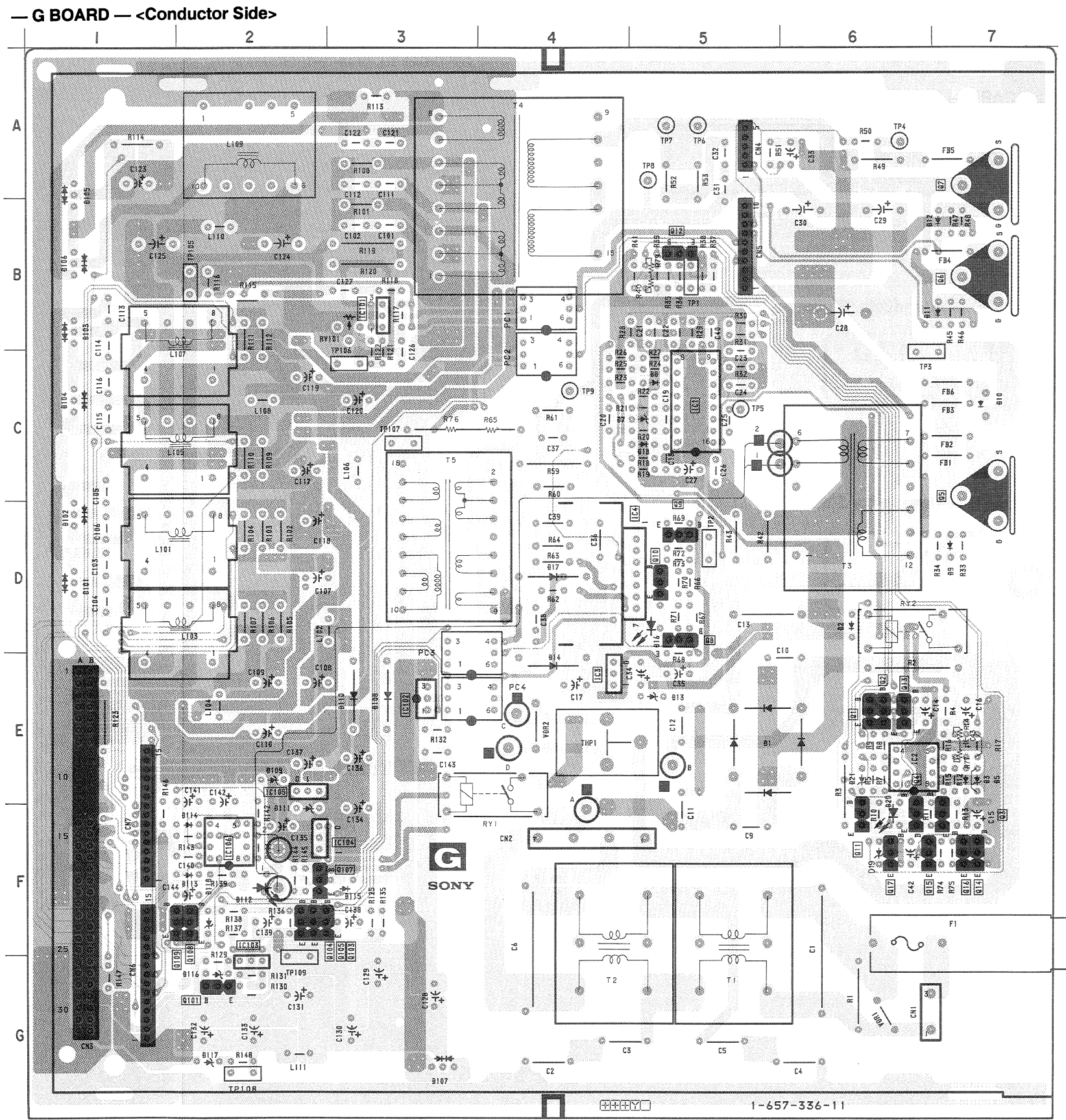




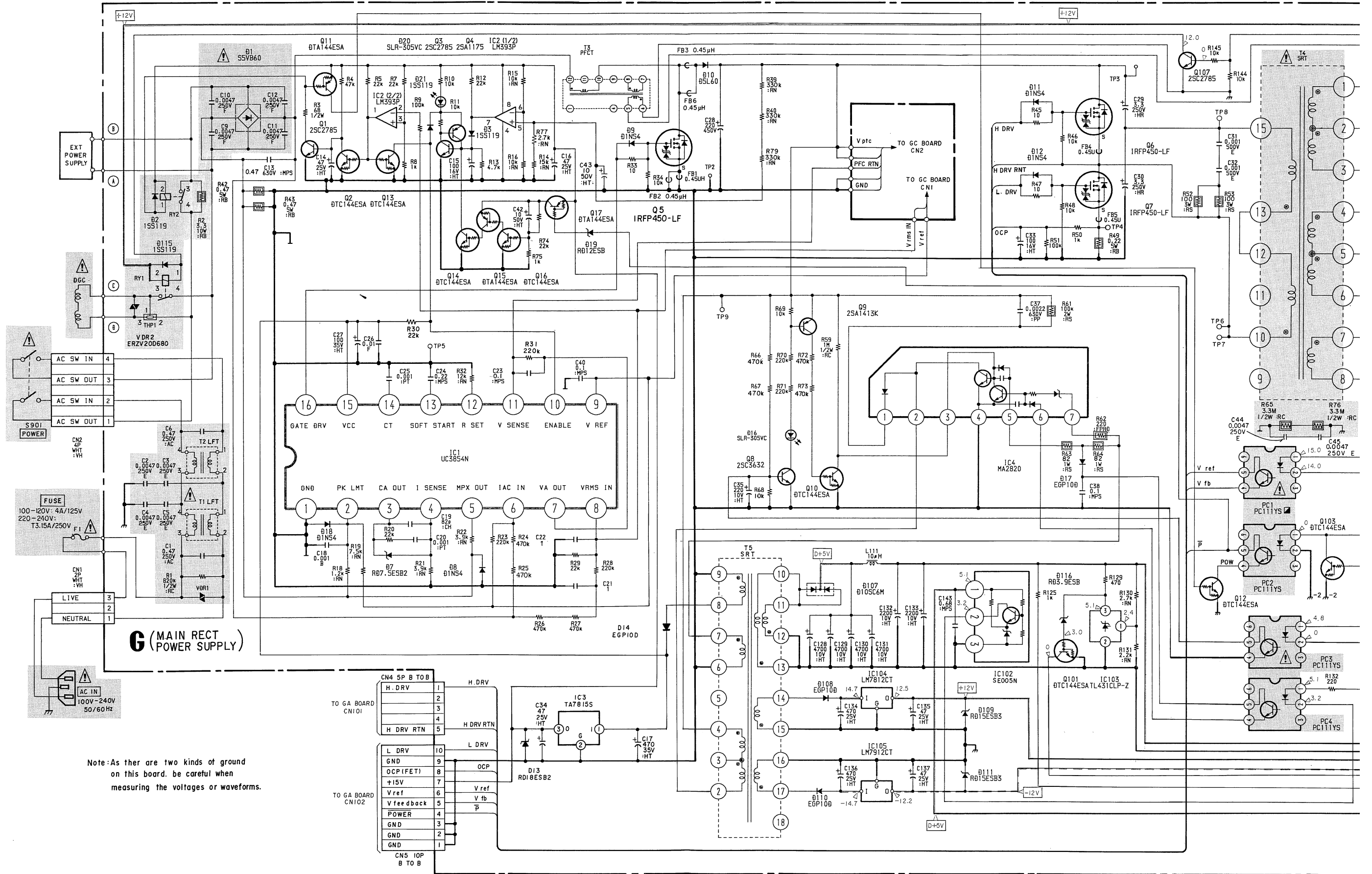
**G** (MAIN RECT, POWER SUPPLY)

**G BOARD**  
SEMICONDUCTOR LOCATION

IC	D12 B-7 D13 E-5
IC1	C-5
IC2	E-6
IC3	E-4
IC4	D-4
IC101	B-3
IC102	E-3
IC103	G-2
IC104	F-2
IC105	E-2
IC106	F-2
TRANSISTOR	D104 C-1 D105 A-1 D106 B-1 D107 G-3 D108 E-3 D109 E-2 D110 E-3 D111 F-2 D112 F-2 D113 F-2
Q1	E-6
Q2	E-6
Q3	F-7
Q4	F-6
Q5	C-7
Q6	B-7
Q7	A-7
Q8	D-5
Q9	D-5
Q10	D-5
Q11	F-6
Q12	B-15
Q13	E-6
Q14	F-7
Q15	F-6
Q16	F-7
Q17	F-6
Q101	G-2
Q103	F-2
Q104	F-2
Q105	F-2
Q107	F-4
Q108	F-4
Q109	F-1
DIODE	D14 E-4 D16 D-5 D17 D-4 D18 C-5 D19 F-6 D20 F-6 D21 E-6 D101 D-1 D102 D-1 D103 B-1
D1	E-5
D2	D-6
D3	E-7
D7	C-5
D8	C-5
D9	D-7
D10	C-7
D11	B-7
	D114 F-2 D115 F-3 D116 G-2 D117 G-2 D118 F-3
	VARIABLE RESISTOR
	RV101 B-3
	TEST POINT
	TP1 B-5 TP2 D-5 TP3 C-6 TP4 A-6 TP5 C-5 TP6 A-5 TP7 A-5 TP8 A-5 TP9 C-4 TP105 B-1
	TP106 C-3 TP107 C-3 TP108 G-2 TP109 G-2

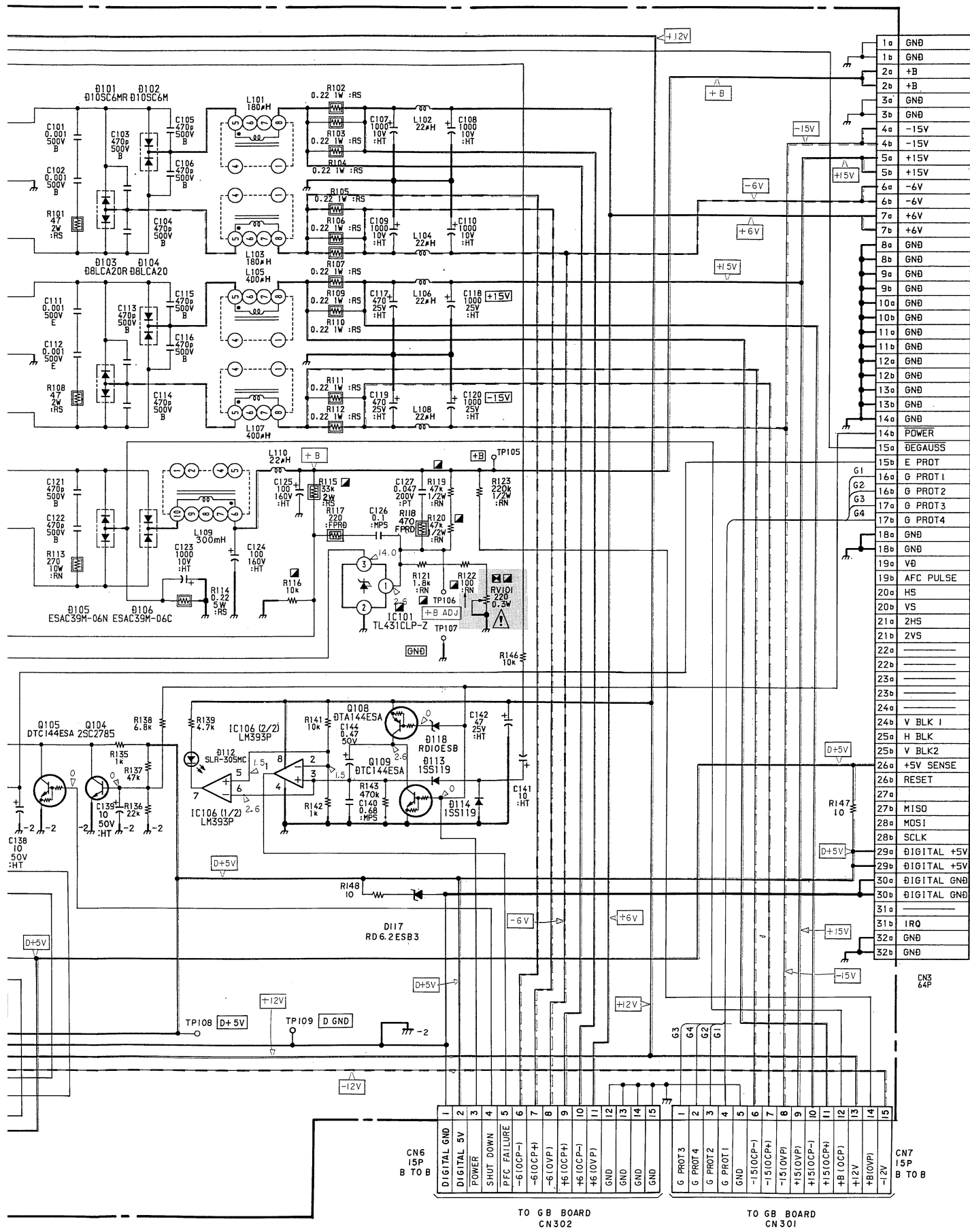


• G (MAIN RECT, POWER SUPPLY) BOARD



Note: As there are two kinds of ground on this board, be careful when measuring the voltages or waveforms.

CN4 SP B TO B	1	H. DRV	H. DRV
	2	H. DRV RTN	H. DRV RTN
	3		
	4	L. DRV	L. DRV
	10	GND	GND
	9	GND	GND
	8	OCPI(FET)	OCPI(FET)
	7	+15V	V ref
	6	V ref	V fb
	5	V feedback	P
	4	POWER	
	3	GND	
	2	GND	
	1	GND	



**G BOARD**  
Function of Semiconductor

1a	GND				
1b	GND				
2a	+B				
2b	+B				
3a	GND				
3b	GND				
4a	-15V				
4b	-15V				
5a	+15V				
5b	+15V				
6a	-6V				
6b	-6V				
7a	+6V				
7b	+6V				
8a	GND				
8b	GND				
9a	GND				
9b	GND				
10a	GND				
10b	GND				
11a	GND				
11b	GND				
12a	GND				
12b	GND				
13a	GND				
13b	GND				
14a	GND				
14b	POWER				
15a	DEGAUSS				
15b	E PROT				
16a	G PROT1				
16b	G PROT2				
17a	G PROT3				
17b	G PROT4				
18a	GND				
18b	GND				
19a	V <sub>B</sub>				
19b	AFC PULSE				
20a	HS				
20b	VS				
21a	2HS				
21b	2VS				
22a					
22b					
23a					
23b					
24a					
24b	V BLK 1				
25a	H BLK				
25b	V BLK2				
26a	+5V SENSE				
26b	RESET				
27a					
27b	MISO				
28a	MOSI				
28b	SCLK				
29a	DIGITAL +5V				
29b	DIGITAL +5V				
30a	DIGITAL GND				
30b	DIGITAL GND				
31a					
31b	IRQ				
32a	GND				
32b	GND				
IC1	UC3854N	PFC CONTROL	D5	RD7.5ES-B2	DC LEVEL SHIFT
2	LM393P	AC IN DET, PFC OUT OVP	7	RD7.5ES-B2	CLAMP
3	LM7815CT	+15V REG	8	D1NS4	CLAMP
4	MA2820	RCC SWITCHING	9	D1NS4	SPEED UP
101	TL431CLP-Z	+B REG	10	D5L60	FLYHOOL
102	SE005N	+5V REG	11	D1NS4	SPEED UP
103	TL431CLP-Z	+5V OVP	12	D1NS4	SPEED UP
104	LM7812CT	12V REG	13	RD18ESB2	PROTECTOR
105	LM7912CT	-12V REG	14	EGP10DPKG23	+18V RECT
106	LM393P	PFC FAILUVE DET	16	SEL6210S-D	RCC FAIL PILOT
			17	EGP10DPKG23	RECT
Q1	2SC2785-HFE	RELAY DRIVE	18	D1NS4	CLAMP
2	DTC144ESA	DISCHARGE	19	RD12ES-B	DC LEVEL SHIFT
3	2SC2785-HFE	LATCH	20	SEL6210S-D	PFC OVP PILOT
4	2SA1175-HFE	LATCH	21	1SS119	SWITCH
5	1RFP450LF	PFC SWITCHING	101	D10SC6MR	-6V RECT
6	1RFP450LF	HIGH SIDE SWITCHING	102	D10SC6M	+6V RECT
7	1RFP450LF	LOW SIDE SWITCHING	103	D8LCA20R	-15V RECT
8	2SC3632-M	RCC PROTECTOR	104	D8LCA20	+15V RECT
9	2SC3632-M	RCC PROTECTOR	105	ESAC39M-06N	+B RECT
10	DTC144ESA	RCC PROTECTOR	106	ESAC39M-06C	+B RECT
11	DTA144ESA	INRUSH FAILUVE	107	D10SC6M	DIGITAL 5V RECT
12	DTC144ESA	SOFT START	108	EGP10DPKG23	+15V RECT
13	DTC144ESA	PFC STOP	109	RD15ES-B3	PROTECTOR
14	DTC144ESA	PWR ON RESET	110	EGP10DPKG23	-15V RECT
15	DTA144ESA	PWR ON RESET	111	RD15ES-B3	PROTECTOR
16	DTC144ESA	PWR ON RESET	112	SEL6410E-D	PFC PILOT
17	DTA144ESA	SWITCH	113	1SS119	RECT
101	DTC144ESA	PWR SWITCH	114	1SS119	CLAMP
103	DTC144ESA	E PROT SWITCH	115	1SS119	CLAMP
104	2SC2785-HFE	PWR SW	116	RD3.9ES-B	DC LEVEL SHIFT
105	DTC144ESA	SHUT DWN SW	117	RD6.2ES-B3	PROTECTOR
107	2SC2785-HFE	DGC SWITCH	118	10V	DC LEVEL SHIFT
108	DTA144ESA	PWR ON RESET			
109	DTC144ESA	PWR ON RESET	PC1	PC111YS	+B REG ISOLATOR
			PC2	PC111YS	PWR ISOLATOR
D1	S5VB60	MAIN RECT	PC3	PC111YS	RCC PROTECT ISOLATOR
2	1SS119	CLAMP	PC4	PC111YS	+5V REG ISOLATOR
3	1SS119	SWITCH			

• GA (POWER CONTROL), GB (O.V.P, O.C.P), GC (PFC OUT, GAIN CONTROL) BOARD

GA BOARD

Function of Semiconductor

IC101	IR2112	HALF BRIDGE DRIVER
102	TL494CNS-E20	HALF BRIDGE PWM CONTROL
Q101	2SC2412K-Q	POWER SW
102	2SA1037K-Q	SOFT START
103	2SC2412K-Q	SOFT START
D101	MA110-TX	LEVEL SHIFT
102	SC311-6	PROTECTOR
103	SC311-6	PROTECTOR
104	RD18M-B2	PROTECTOR
105	MA110-TX	PROTECTOR
106	MA110-TX	PROTECTOR
107	MA110-TX	PROTECTOR
108	MA110-TX	PROTECTOR

GB BOARD

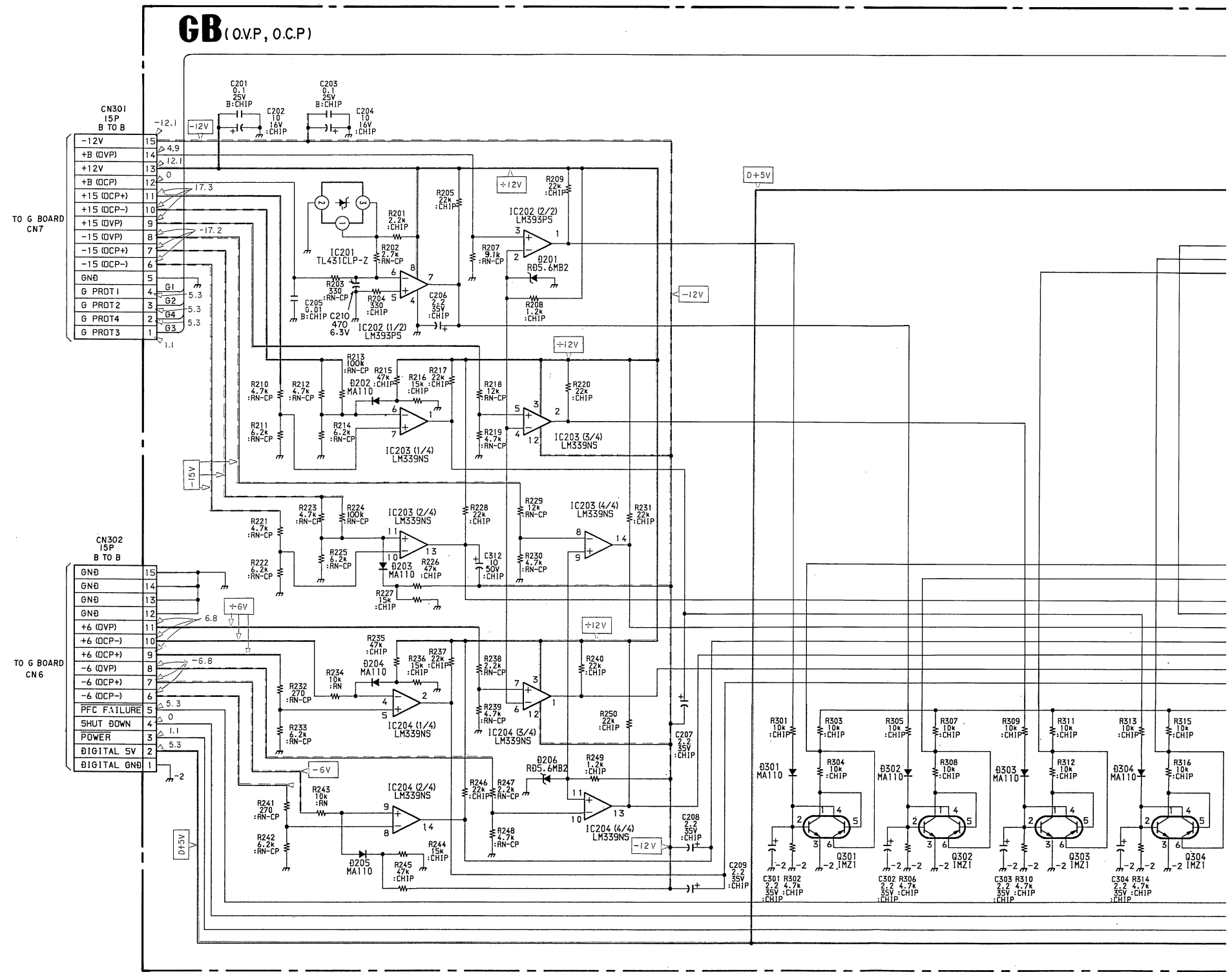
Function of Semiconductor

IC201	TL431CLP-Z	+B OCP REF
202	LM393PS	+B O.V.P/O.C.P DETECTOR
203	LM339NS-E20	±15V O.V.P/O.C.P DETECTOR
204	LM339NS-E20	±6V O.V.P/O.C.P DETECTOR
301	TC74HC148AF	PROTECTOR ENCODER
302	TC74HC148AF	PROTECTOR ENCODER
303	MC74HC08AF	PROTECTOR ENCODER
Q301	IMZ1T109	+B O.V.P
302	IMZ1T109	+B O.C.P
303	IMZ1T109	+15V O.V.P
304	IMZ1T109	+15V O.C.P
305	IMZ1T109	-15V O.V.P
306	IMZ1T109	-15V O.C.P
307	IMZ1T109	+6V O.C.P
308	IMZ1T109	+6V O.V.P
309	IMZ1T109	-6V O.V.P
310	IMZ1T109	-6V O.C.P
311	2SA1037K-Q	POWER SW
312	DTA144EKA	POWER RESET
313	DTA144EKA	PFC PROTECT
D201	RD5.6M-B2	OVP REF
202	MA110-TX	SWITCH
203	MA110-TX	SWITCH
204	MA110-TX	SWITCH
205	MA110-TX	SWITCH
206	RD5.6M-B2	OVP REF
301	MA110-TX	SWITCH
302	MA110-TX	SWITCH
303	MA110-TX	SWITCH
304	MA110-TX	SWITCH
305	MA110-TX	SWITCH
306	MA110-TX	SWITCH
307	MA110-TX	SWITCH
308	MA110-TX	SWITCH
309	MA110-TX	SWITCH
310	MA110-TX	SWITCH

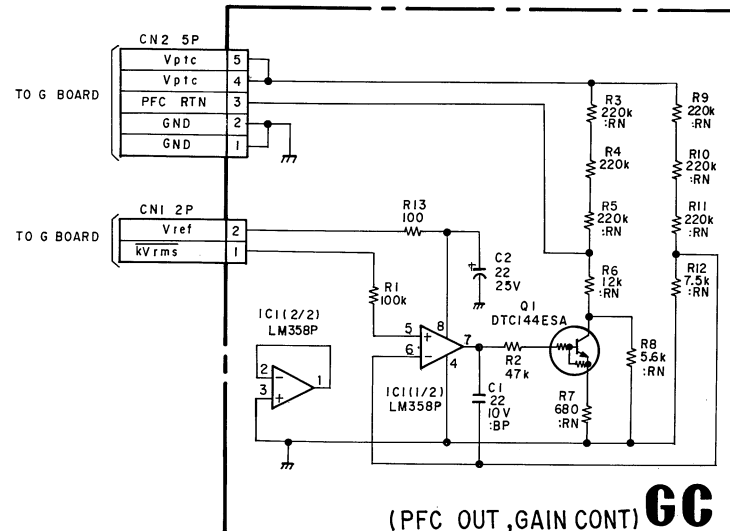
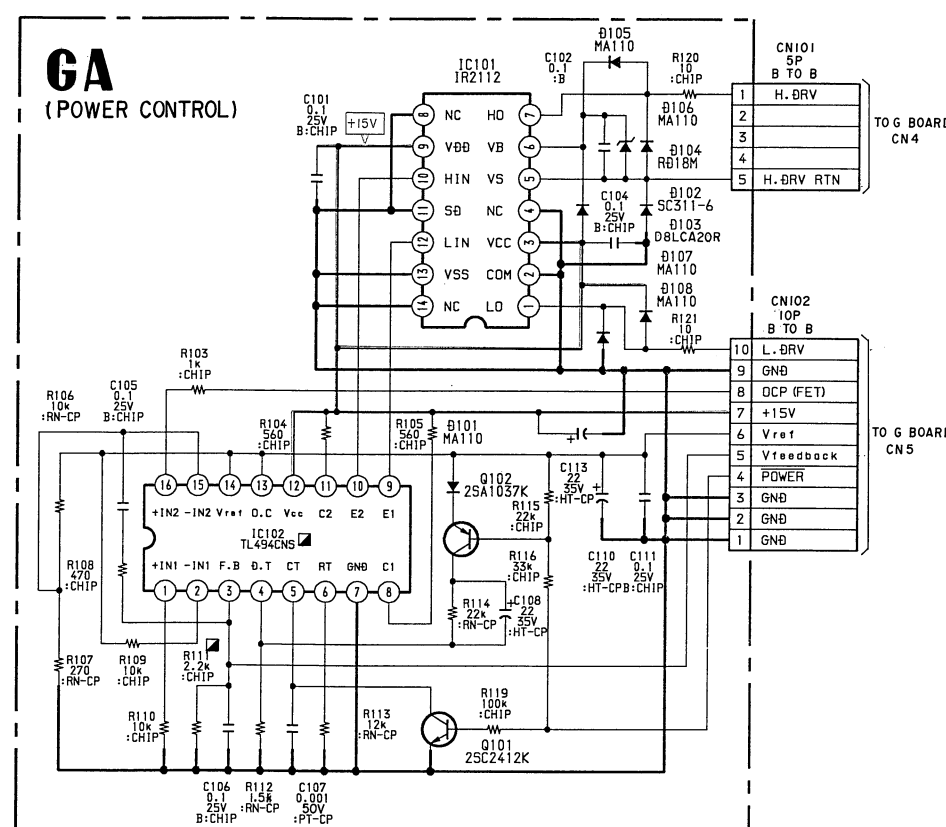
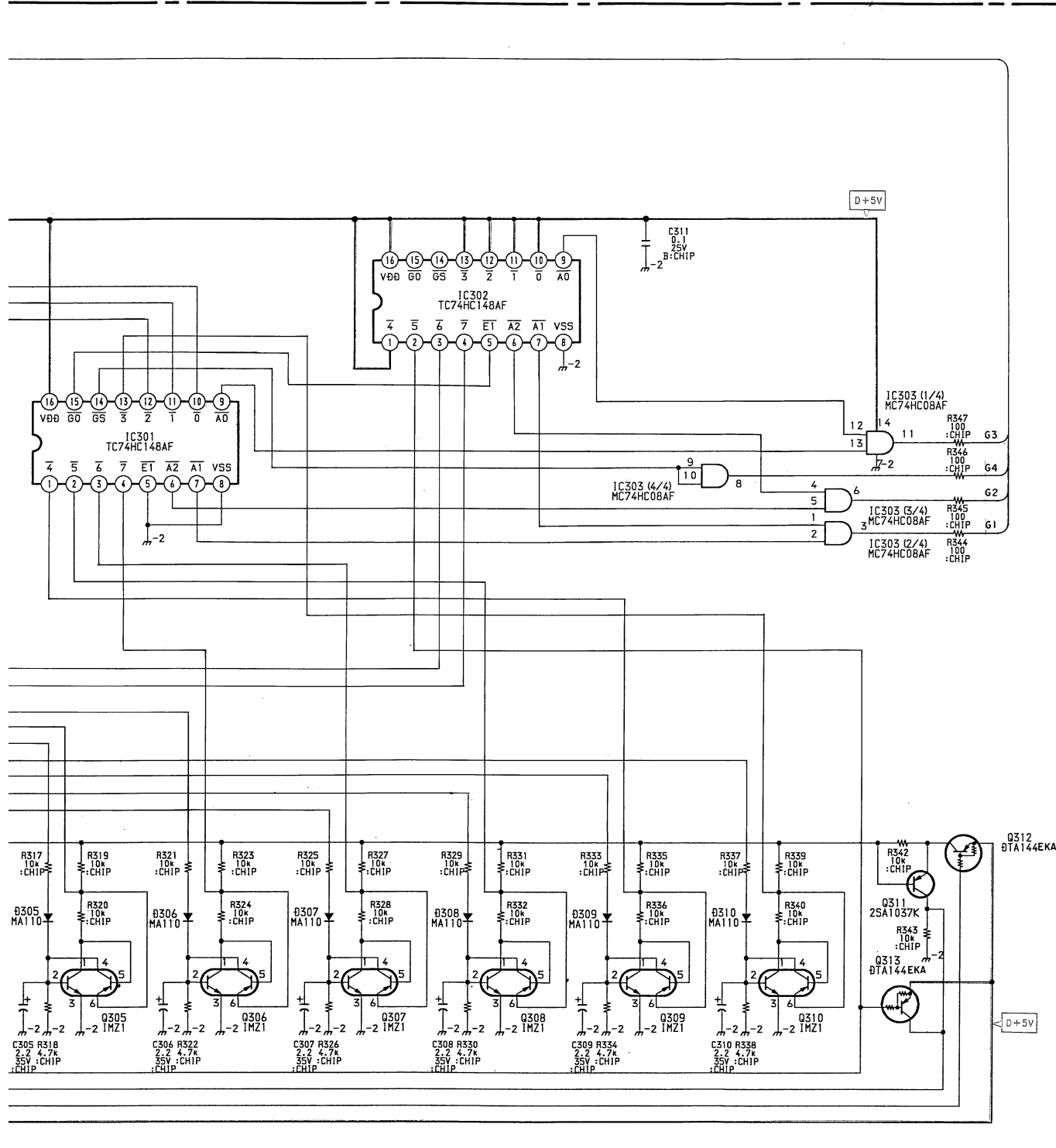
GC BOARD

Function of Semiconductor

IC1	LM358P	GAIN CONTROL
Q1	DTC144ESA	PFC OUT



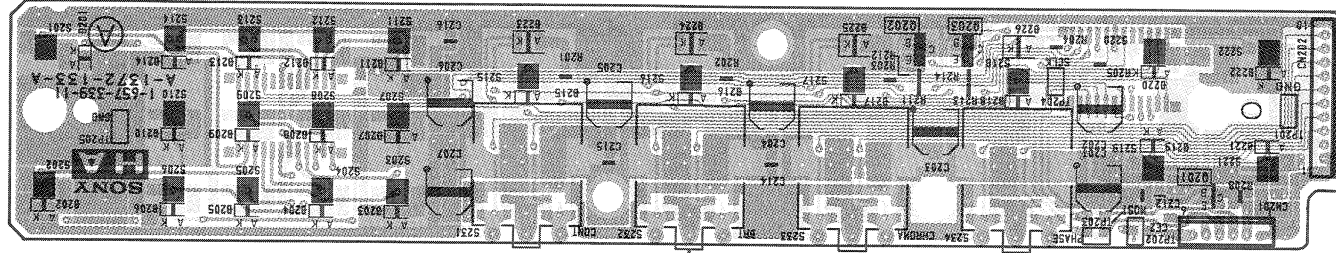




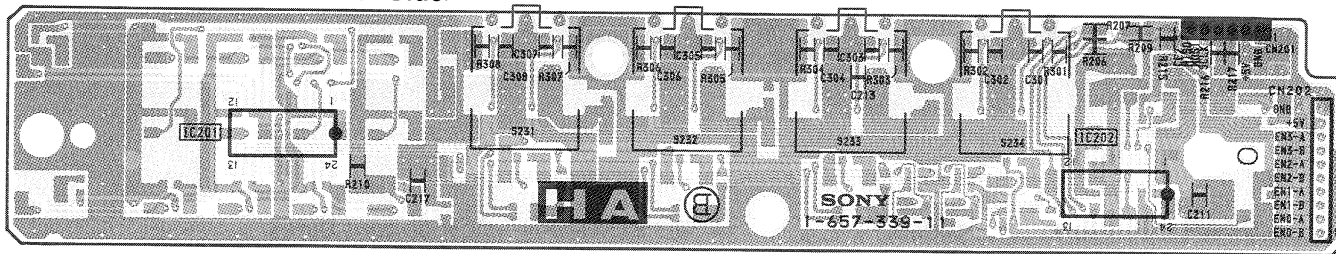


**HA** (FUNCTION CONTROL) (BVM-14E5E/14E5U/14F5E/14F5U, BKM-10R)

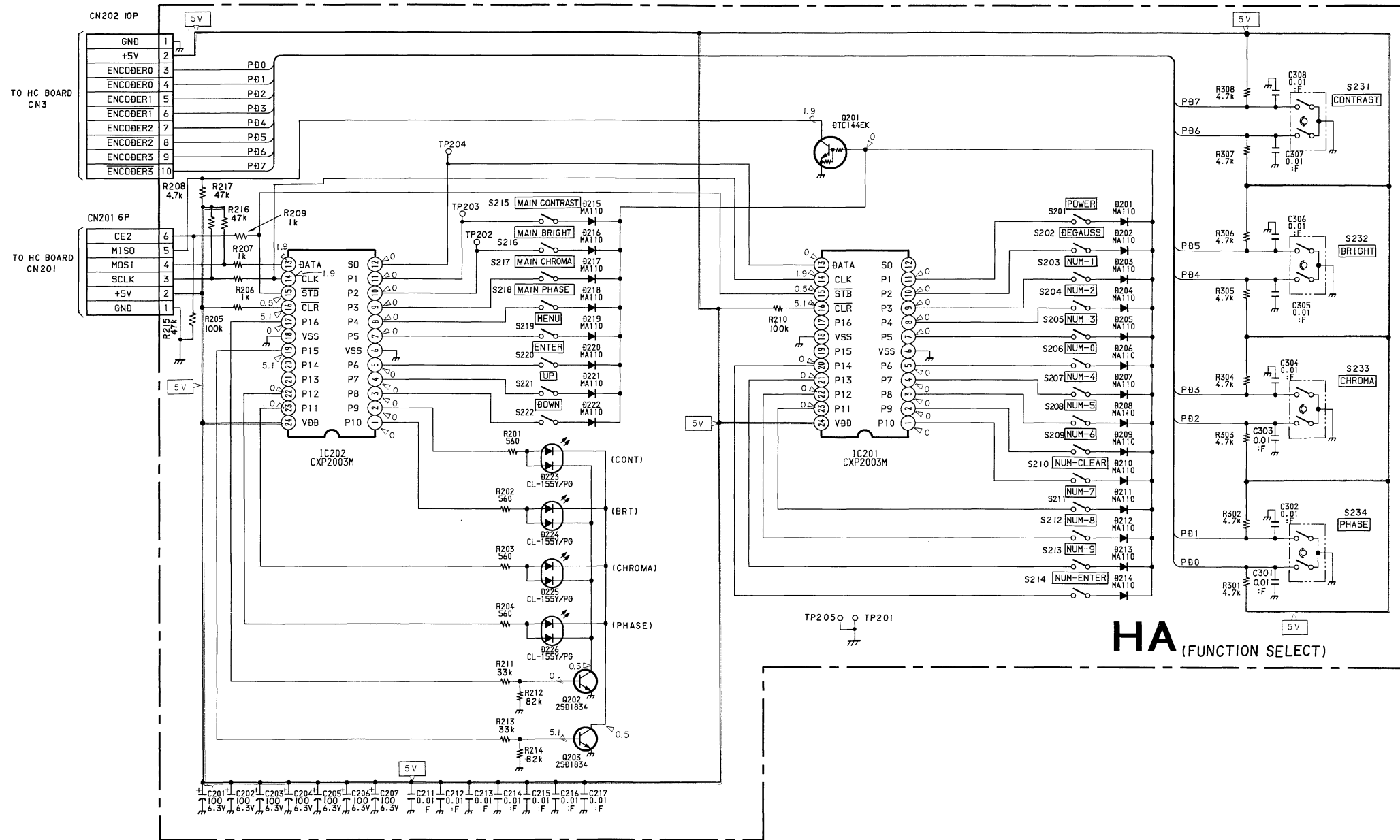
— HA BOARD — <Component Side>



— HA BOARD — <Conductor Side>



• HA (FUNCTION CONTROL) BOARD (BVM-14E5E/14E5U/14F5E/14F5U, BKM-10R)



HA BOARD  
Function of Semiconductor

IC201	CXP2003M	S/P CONV 1
202	CXP2003M	S/P CONV 2
Q201	DTC144EK	SWITCH OUT
202	2SD1834	ORANGE DRIVE
203	2SD1834	GREEN DRIVE
D201	MA110	SWITCH
202	MA110	SWITCH
203	MA110	SWITCH
204	MA110	SWITCH
205	MA110	SWITCH
206	MA110	SWITCH
207	MA110	SWITCH
208	MA110	SWITCH
209	MA110	SWITCH
210	MA110	SWITCH
211	MA110	SWITCH
212	MA110	SWITCH
213	MA110	SWITCH
214	MA110	SWITCH
215	MA110	SWITCH
216	MA110	SWITCH
217	MA110	SWITCH
218	MA110	SWITCH
219	MA110	SWITCH
220	MA110	SWITCH
221	MA110	SWITCH
222	MA110	SWITCH
223	CL155Y/PG-CD	INDICATOR(CONT MANUAL)
224	CL155Y/PG-CD	INDICATOR(BRT MANUAL)
225	CL155Y/PG-CD	INDICATOR(CHR MANUAL)
226	CL155Y/PG-CD	INDICATOR(PHA MANUAL)

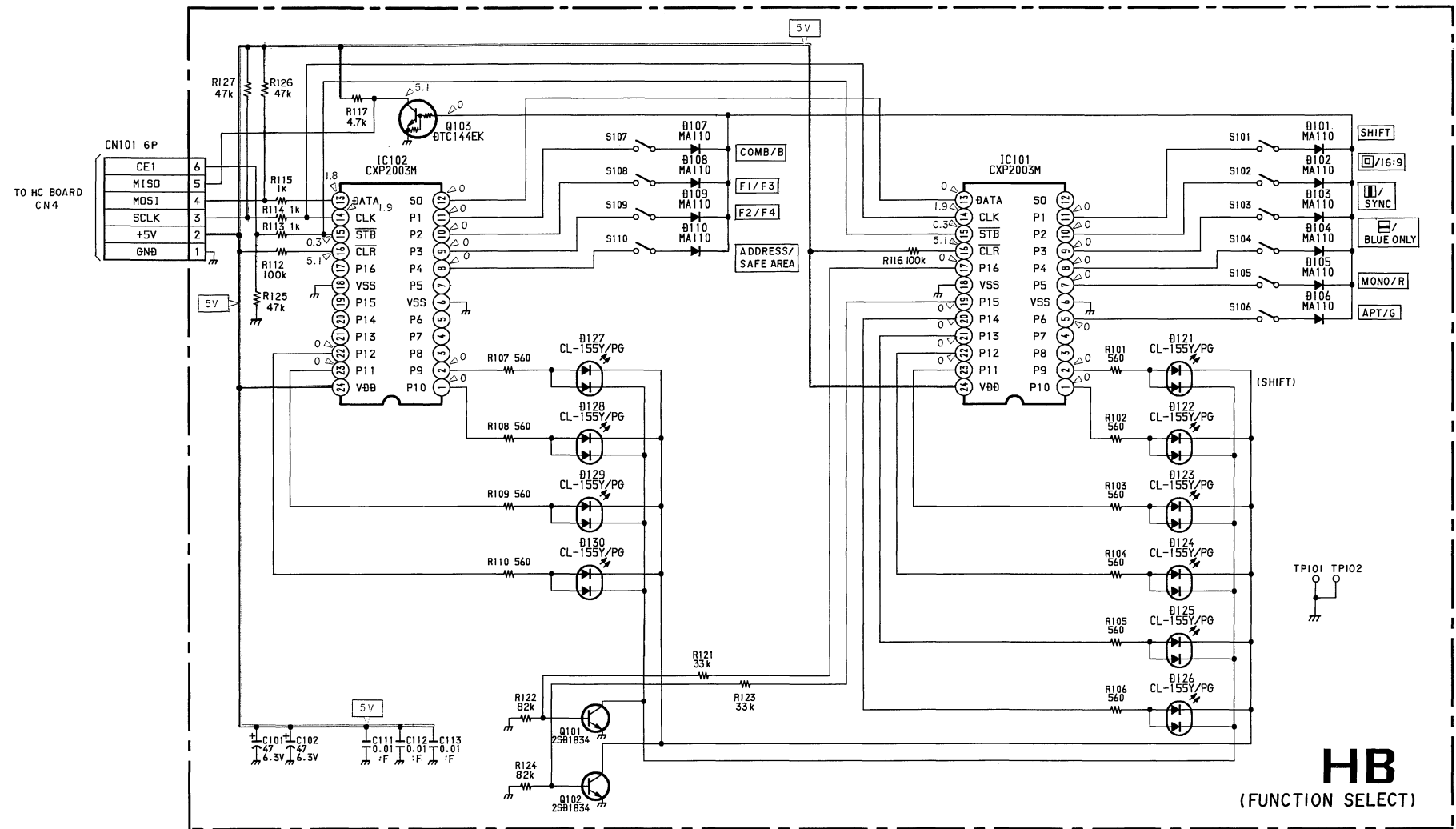
HA (FUNCTION SELECT)

• HB (FUNCTION CONTROL) BOARD (BVM-14E5E/14E5U/14F5E/14F5U, BKM-10R)

HB BOARD

Function of Semiconductor

IC101	CXP2003M	S/P CONV 1
102	CXP2003M	S/P CONV 2
Q101	2SD1834	ORANGE DRIVE
102	2SD1834	GREEN DRIVE
103	DTC144EK	SWITCH OUT
D101	MA110	SWITCH
102	MA110	SWITCH
103	MA110	SWITCH
104	MA110	SWITCH
105	MA110	SWITCH
106	MA110	SWITCH
107	MA110	SWITCH
108	MA110	SWITCH
109	MA110	SWITCH
110	MA110	SWITCH
121	CL-155Y/PG-CD	INDICATOR(SHIFT)
122	CL-155Y/PG-CD	INDICATOR(UND/16:9)
123	CL-155Y/PG-CD	INDICATOR(H DLY/SYNC)
124	CL-155Y/PG-CD	INDICATOR(V DLY/BLUE ONLY)
125	CL-155Y/PG-CD	INDICATOR(MONO/R)
126	CL-155Y/PG-CD	INDICATOR(APT/G)
127	CL-155Y/PG-CD	INDICATOR(COMB/B)
128	CL-155Y/PG-CD	INDICATOR(F1/F3)
129	CL-155Y/PG-CD	INDICATOR(F2/F4)
130	CL-155Y/PG-CD	INDICATOR(ADDR/SAD)

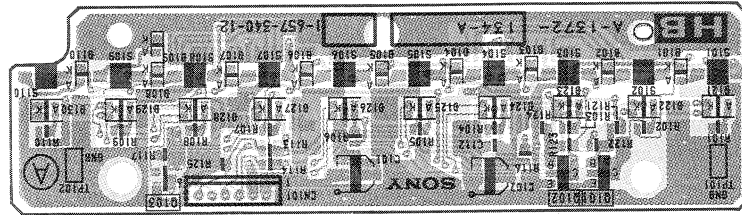


HB  
(FUNCTION SELECT)

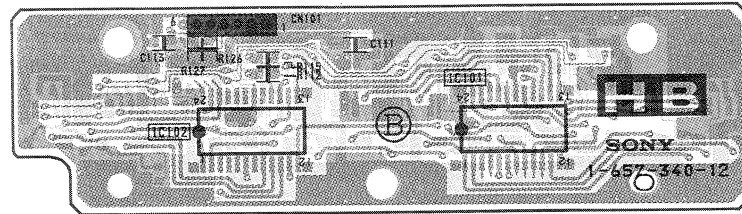
**HB**

(FUNCTION CONTROL) (BVM-14E5E/14E5U/14F5E/14F5U, BKM-10R)

— HB BOARD — <Component Side>



— HB BOARD — <Conductor Side>



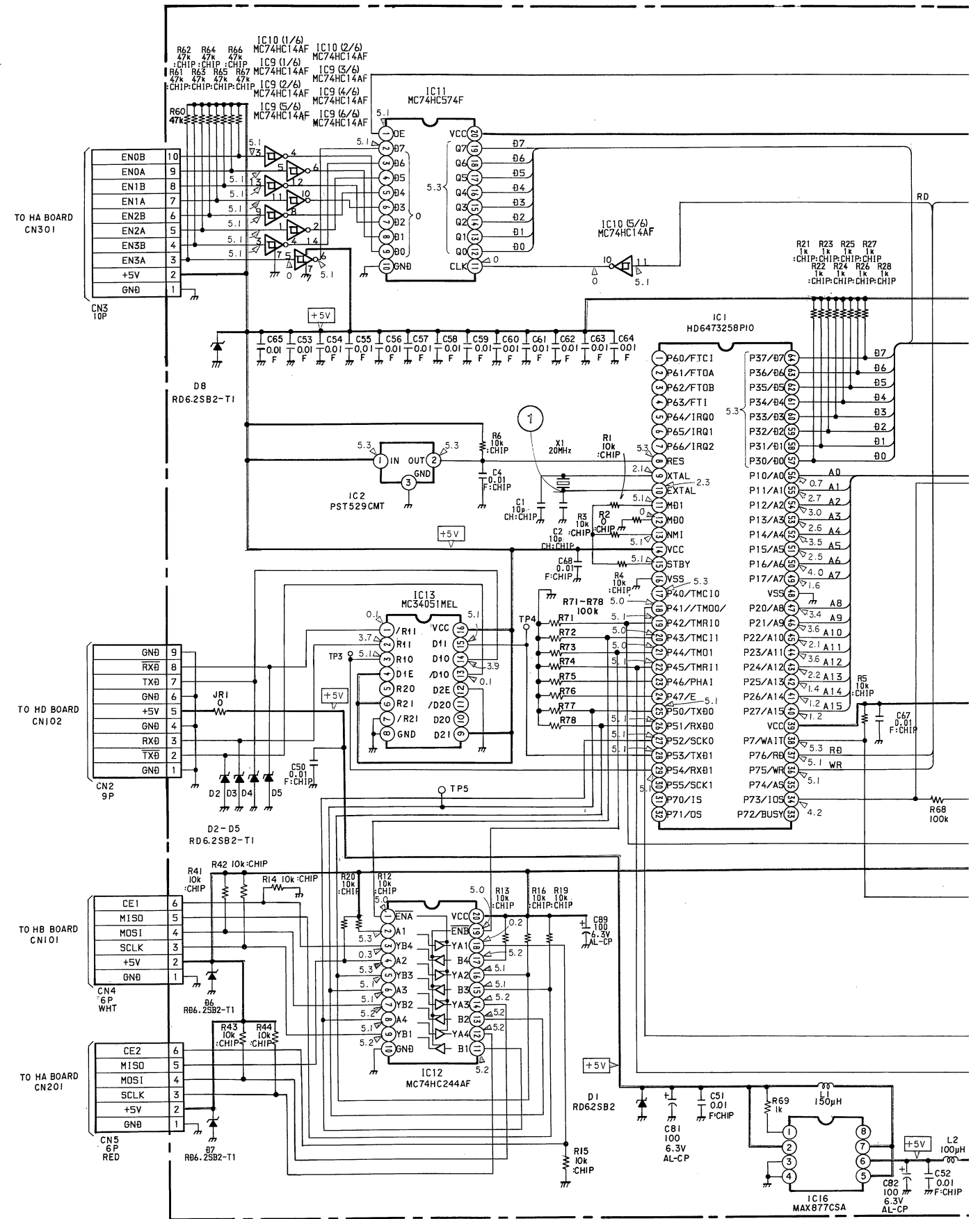




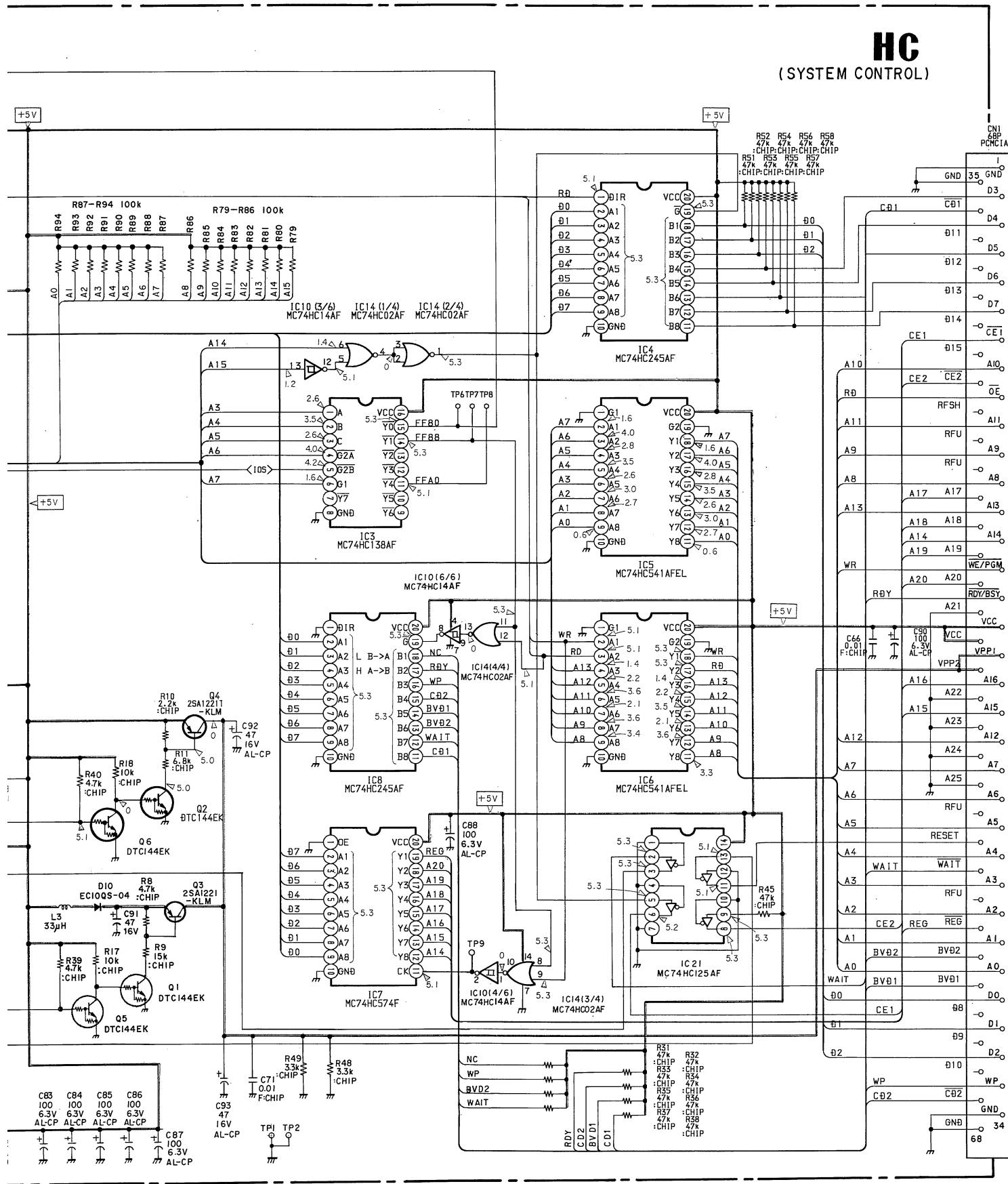
HC BOARD  
SEMICONDUCTOR  
LOCATION

• HC (SYSTEM CONTROL) BOARD (BVM-14E5E/14E5U/14F5E/14F5U, BKM-10R)

IC	
IC1	B-4
IC2	C-5
IC3	F-3
IC4	B-1
IC5	B-2
IC6	B-2
IC7	B-2
IC8	B-1
IC9	F-5
IC10	F-5
TRANSISTOR	
Q1	E-3
Q2	E-3
Q3	C-3
Q4	C-3
Q5	E-3
Q6	E-3
DIODE	
D1	C-6
D2	C-5
D3	C-5
D4	C-6
D5	C-6
D6	C-4
D7	C-4
D8	B-6
D10	E-3
TEST POINT	
TP1	D-1
TP2	F-5
TP3	D-5
TP4	D-5
TP5	E-4
TP6	G-5
TP7	G-4
TP8	G-3
TP9	F-4



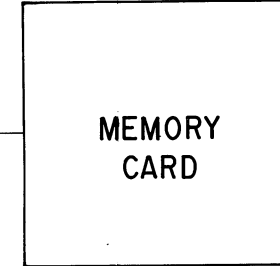




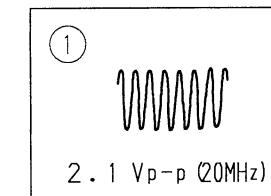
HC BOARD

Function of Semiconductor

IC1	HD6473258P10	CPU
2	PST529CMF-T1	RESET
3	TC74HC138AF	ADDR DECODER
4	TC74HC245AF	BUFFER
5	MC74HC541AFEL	BUFFER
6	MC74HC541AFEL	BUFFER
7	TC74HC574AF	CARD ADDR. HIGH
8	TC74HC245AF	BUFFER
9	TC74HC14AF	INVERTER
10	TC74HC14AF	INVERTER
11	TC74HC574AF	BUFFER
12	TC74HC244AF	BUS SELECT
13	MC34051MEL	RS422 DRIVE
14	SN74HC02ANS	DECODER
16	MAX877CSA	REGULATOR
21	MC74HC125AF	BUFFER
Q1	DTC144EK	VPP 5V SWITCH
2	DTC144EK	VPP 5V SWITCH
3	2SA1221	VPP 5V REG
4	2SA1221	VPP 5V REG
5	DTC144EK	VPP 5V SWITCH
6	DTC144EK	VPP 5V SWITCH
D1	RD6. 2SB2	PROTECTOR
2	RD6. 2SB2	PROTECTOR
3	RD6. 2SB2	PROTECTOR
4	RD6. 2SB2	PROTECTOR
5	RD6. 2SB2	PROTECTOR
6	RD6. 2SB2	PROTECTOR
7	RD6. 2SB2	PROTECTOR
8	RD6. 2SB2	PROTECTOR
10	EC100S04-TE12L5	SW



• HC BOARD Waveform

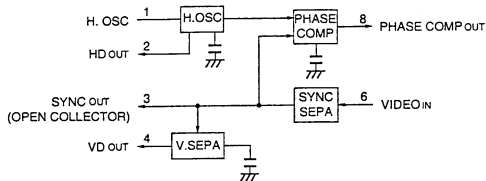
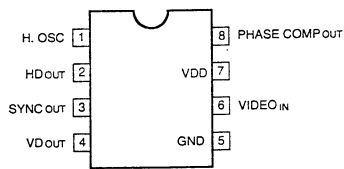




### 5-5. SEMICONDUCTORS

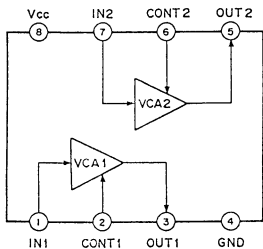
**BA7046F (ROHM)**  
VIDEO SIGNAL SYNC SEPARATOR +AFC

- TOP VIEW -



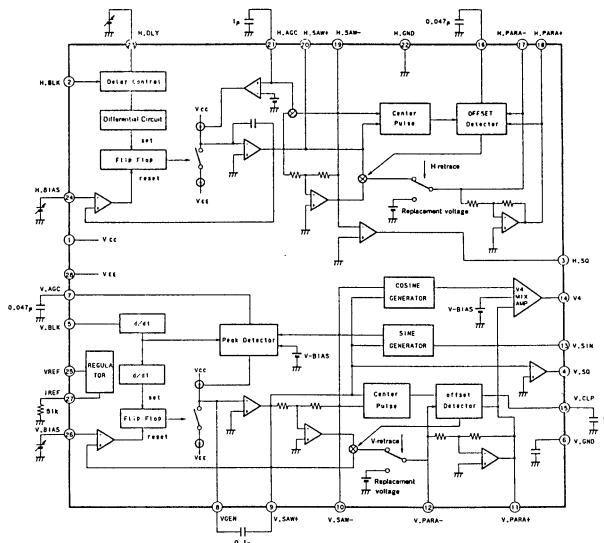
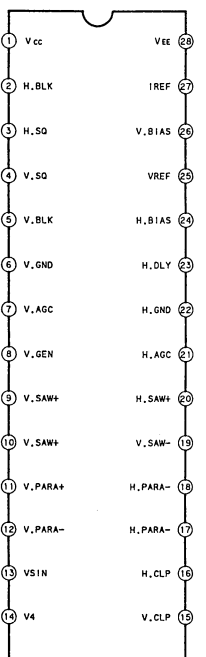
**CXA1211M (SONY)**  
VIDEO SIGNALS AND OTHER WIDE BAND VCA

- TOP VIEW -



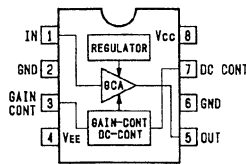
**CXA1470AM (SONY)**  
WAVEFORM GENERATION IC FOR DEFLECTION COMPENSATION

- TOP VIEW -



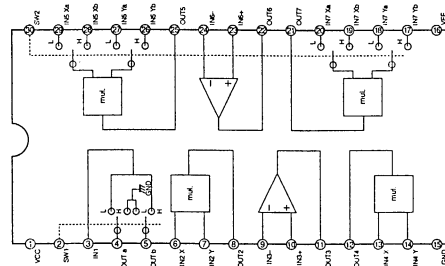
**CXA1521M (SONY)**  
GAIN CONTROL AMP

- TOP VIEW -



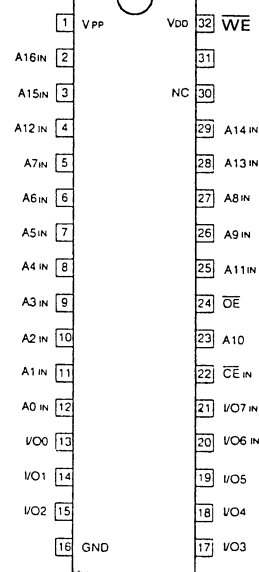
**CXA1726M**  
MULTIPLIER IC FOR DISPLAYS

- TOP VIEW -



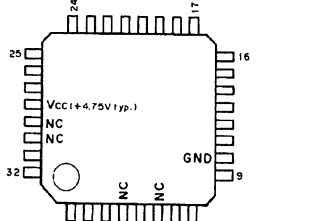
**CAT28F020P (CATALYST SEMICONDUCTOR)**  
C-MOS PROGRAMMABLE ROM

- TOP VIEW -



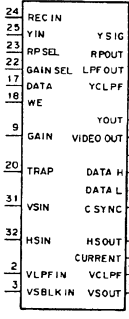
CXA1727Q (SONY)  
ID ADDER/DETECTOR FOR WIDE TV SIGNAL

- TOP VIEW -

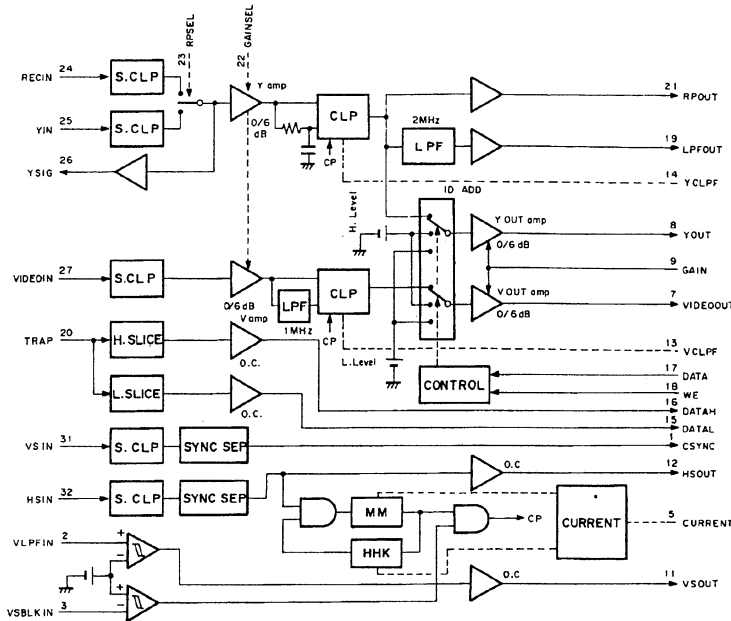


(Vcc = + 4.75V typ.)

PIN No.	Symbol	SIGNAL	PIN No.	Symbol	SIGNAL
1	O	CSYNC	17	I	DATA
2	I	VLPFIN	18	I	WE
3	I	VSBLKIN	19	O	LPFOUT
4	-	NC	20	I	TRAP
5	O	CURRENT	21	O	RPOUT
6	-	NC	22	I	GAINSEL
7	O	VIDEOOUT	23	I	RPSEL
8	O	YOUT	24	I	RECIN
9	I	GAIN	25	I	YIN
10	-	GND	26	O	YSIG
11	O	VSOUT	27	I	VIDEOIN
12	O	HSOUT	28	-	Vcc
13	O	VCLPF	29	-	NC
14	O	YCLPF	30	-	NC
15	O	DATAL	31	I	VSIN
16	O	DATAH	32	I	HSIN

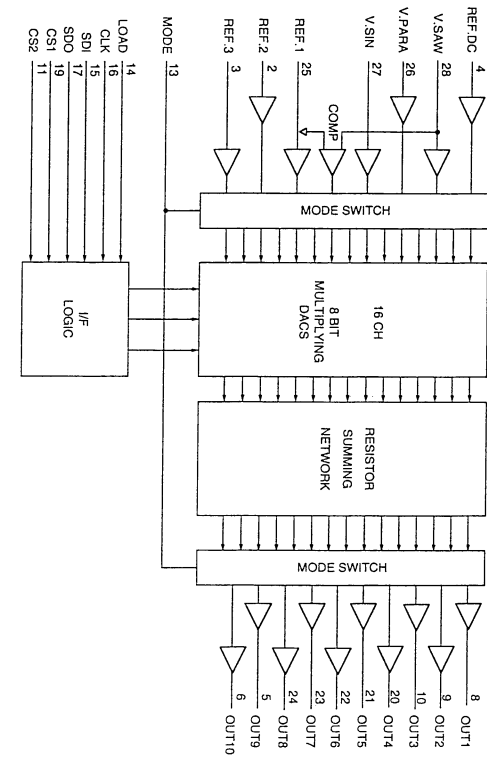
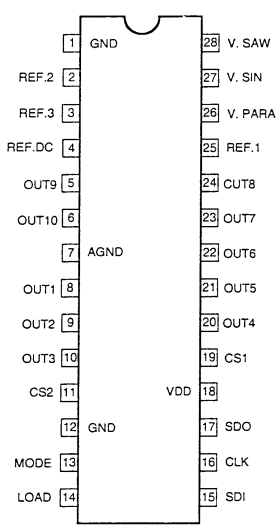


- INPUT**
- DATA : ID DATA
  - GAIN : VIDEO/Y OUT AMP GAIN SELECT
  - GAINSEL : Y AMP GAIN SELECT
  - HSIN : H SYNC SEP.
  - RECIN : REC Y
  - RPSEL : Y R/P SELECT
  - TRAP : TRAPPED Y
  - VIDEOIN : VIDEO
  - VLPFIN : LOW-PASSED CSYNC
  - VSBLKIN : LOW-PASSED CSYNC
  - VSIN : V SYNC SEP.
  - WE : ID WRITE ENABLE
  - YIN : PB Y
- OUTPUT**
- CSYNC : COMPOSITE SYNC
  - DATAH : Y LEVEL HIGH
  - DATAL : Y LEVEL LOW
  - HSOUT : H SYNC
  - LPFOUT : LOW-PASSED Y
  - RPOUT : R/P Y
  - VIDEOOUT : VIDEO
  - VSOUT : V SYNC
  - YOUT : Y MAIN
  - YSIG : R/P SELECTED Y
- OTHER**
- CURRENT : REF CURRENT RESISTOR
  - VCLPF : CAPACITOR FOR VIDEO CLAMP
  - YCLPF : CAPACITOR FOR Y CLAMP



CXA8021M (SONY)  
C-MOS 16 CHANNEL INDEPENDENT 8 BIT ADJUSTMENT DAC

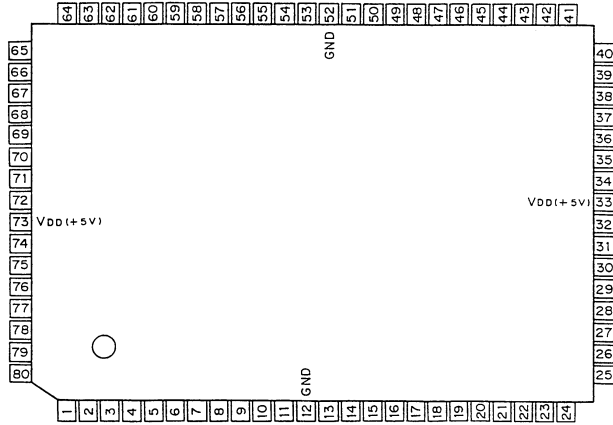
- TOP VIEW -





CXD1132Q (SONY) FLAT PACKAGE  
C-MOS TIME CODE GENERATOR/READER

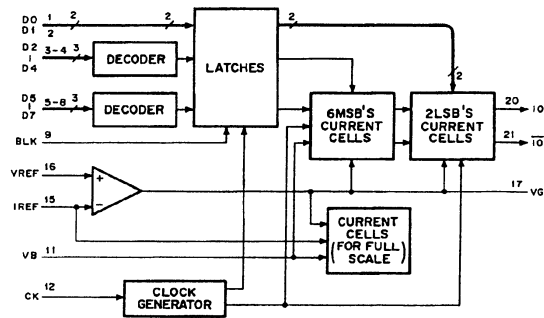
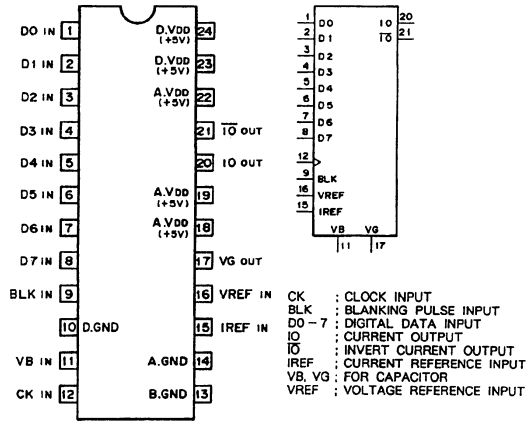
- TOP VIEW -



PIN NO.	I/O	SYMBOL	PIN NO.	I/O	SYMBOL	PIN NO.	I/O	SYMBOL	PIN NO.	I/O	SYMBOL	PIN NO.	I/O	SYMBOL
1	I/O	DB5	17	I	CCS	33	-	VDD	49	I	C1MI	65	I	TCIN
2	I/O	DB4	18	I	CWR	34	I/O	DA1	50	O	C1MO	66	O	DCLK
3	I/O	DB3	19	I	CRD	35	I/O	DA0	51	O	C2MO	67	O	DATA
4	I/O	DB2	20	O	INT	36	I	DSP	52	-	GND	68	O	RFLD
5	I/O	DB1	21	I	STBY	37	O	DTSE	53	O	CKO	69	O	RDSY
6	I/O	DB0	22	I	TST1	38	O	VRCK	54	I	CKIN	70	O	LRP
7	O	STOP	23	I	TST2	39	I	SLLM	55	I	SLCK	71	O	BUSY
8	I/O	D7	24	I	TST3	40	O	RVDO	56	I	GCSI	72	I	BA2
9	I/O	D6	25	I	PON	41	I	RCSI	57	I	S1	73	-	V <sub>int</sub>
10	I/O	D5	26	I	FLD1	42	I	VITC	58	O	VTGO	74	I	BA1
11	I/O	D4	27	I	RTIM	43	I	FRMI	59	O	VTO	75	I	BA0
12	-	GND	28	I	CDIR	44	O	FRMO	60	O	LTCO	76	I	BWR
13	I/O	D3	29	I	CTLI	45	O	GLSY	61	I	LRES	77	I	BRD
14	I/O	D2	30	I/O	DWR	46	I	HDI	62	I	VCEI	78	I	BCS
15	I/O	D1	31	I/O	DA3	47	O	HDO	63	O	LSHO	79	I/O	BD7
16	I/O	D0	32	I/O	DA2	48	O	VDO	64	I	C2MI	80	I/O	BD6

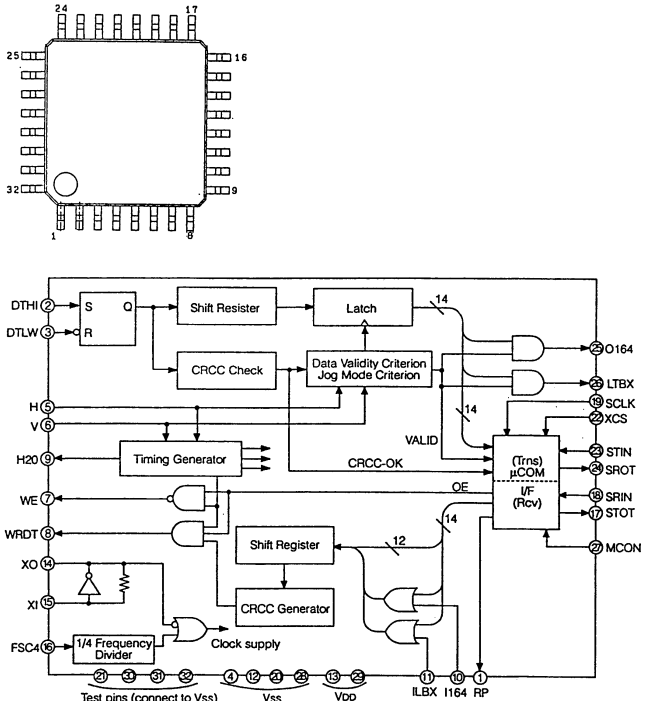
CXD1171M (SONY) FLAT PACKAGE  
C-MOS 8-BIT D/A CONVERTER

- TOP VIEW -



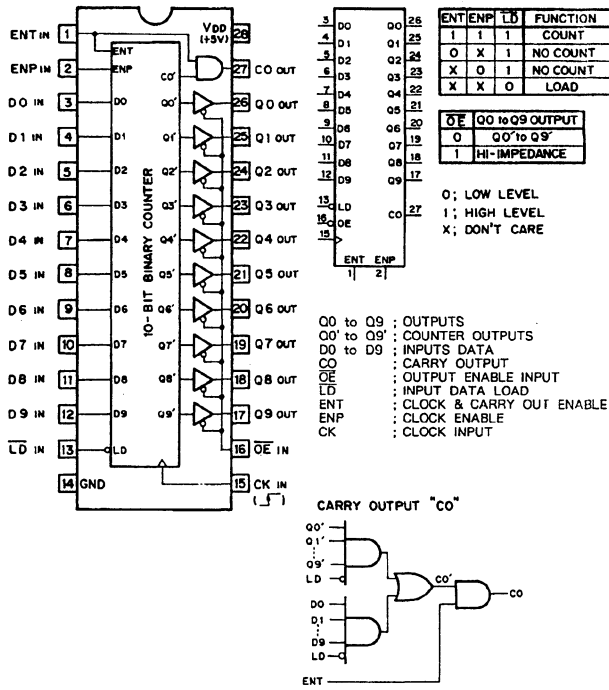
CXD2122AQ  
VIDEO ASPECT RATIO IDENTIFICATION SIGNAL ENCODER/DECODER

- TOP VIEW -



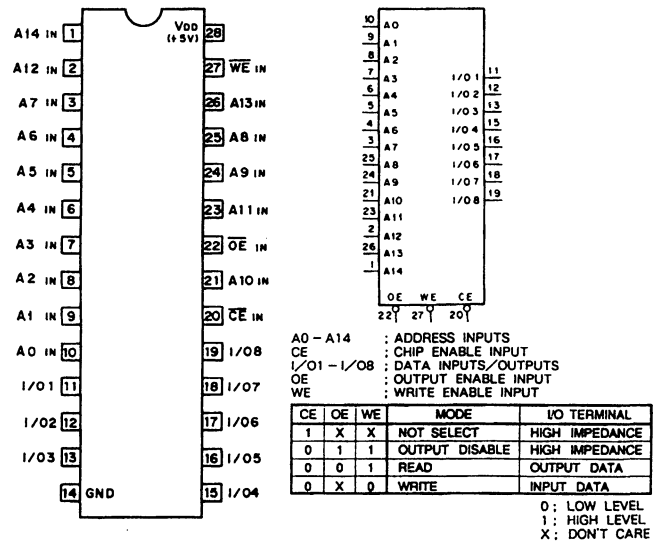
CXD2343S (SONY)  
N-MOS SYNCHRONOUS 10-BIT BINARY COUNTER

- TOP VIEW -



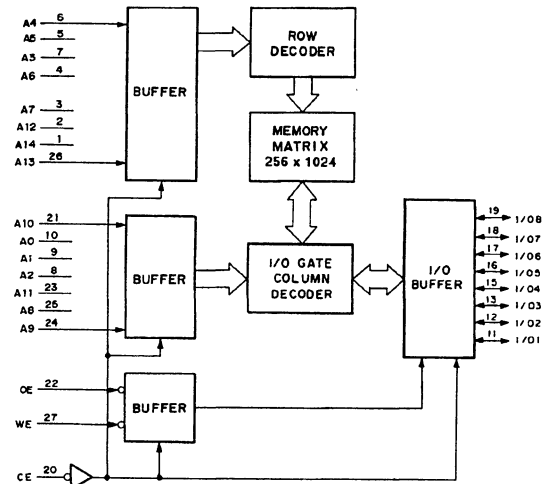
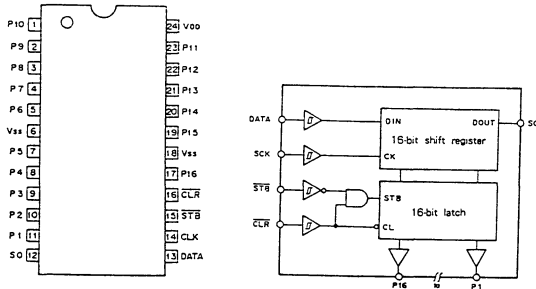
CXK58257AP10LL (SONY)  
C-MOS 32768-WORDx8-BIT STATIC RAM

- TOP VIEW -



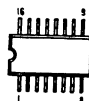
CXP2003M  
C-MOS SERIAL TO PARALLEL CONVERTER

- TOP VIEW -



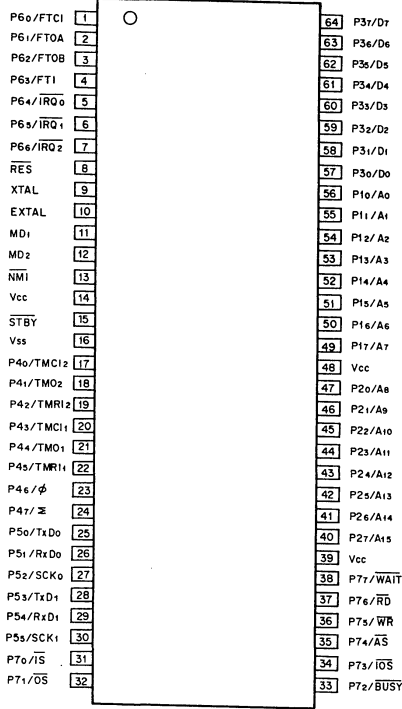
FA5301N

- TOP VIEW -



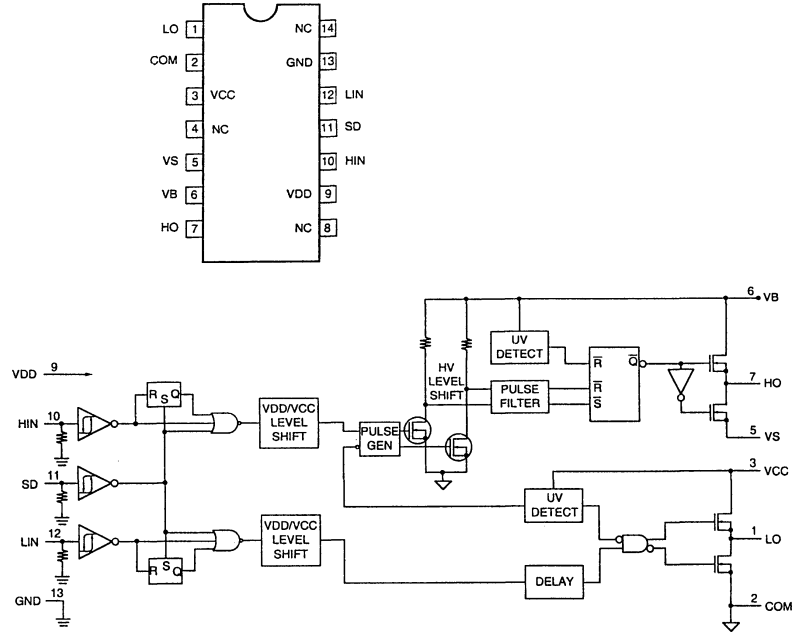
**HD6473258P10**  
C-MOS 8 BIT CHIP ONE CHIP MICROCOMPUTER FOR MONITOR

- TOP VIEW -



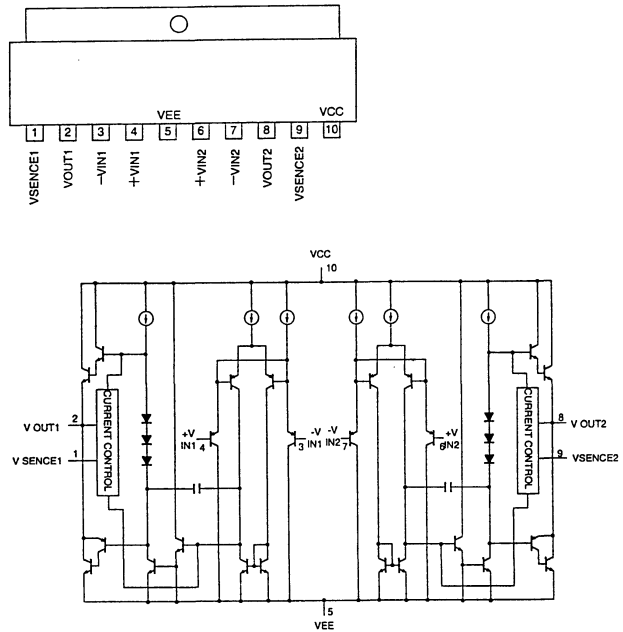
**IR2112 (IRF)**  
C-MOS HIGH VOLTAGE MOS GATE DRIVER

- TOP VIEW -



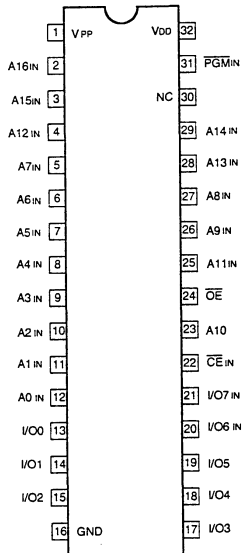
**LA6510 (SANYO)**  
DUAL POWER OPERATIONAL AMPLIFIER

- SIDE VIEW -



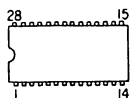
**HN27C101AG-12 (HITACHI)**  
C-MOS PROGRAMABLE ROM

- TOP VIEW -



**HN27C256AG-10**

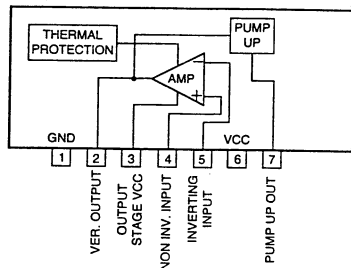
- TOP VIEW -





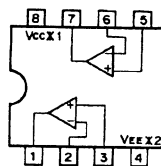
**LA7845 (SANYO)**  
VERTICAL OUTPUT FOR TV DISPLAY

- SIDE VIEW -



**LM358PS**  
DUAL OPERATIONAL AMPLIFIERS

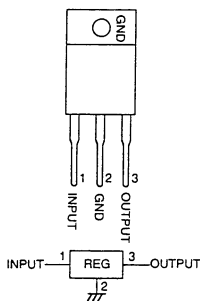
- TOP VIEW -



	Vcc*1	Vee*2
SINGLE SUPPLY	+3 to +32V	GND
SPLIT SUPPLIES	+1.5 to +16V	- 1.5 to - 16V

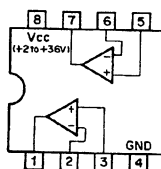
**LM2940CT-5.0 (NSC)**  
C-MOS LOW DROPOUT REGULATOR

- PRINTED SIDE VIEW -



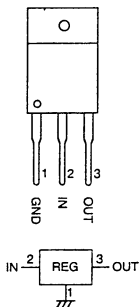
**LM393P**  
**LM393PS**  
 $\mu$ PC393G2

- TOP VIEW -



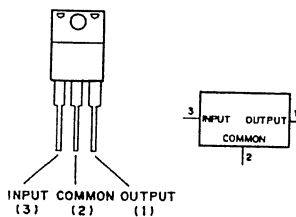
**LM2990T-5.0 (NSC)**  
C-MOS NEGATIVE LOW DROPOUT REGULATOR

- PRINTED SIDE VIEW -



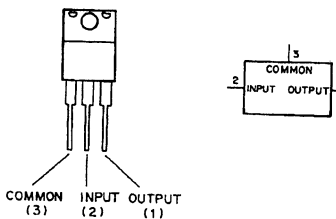
**LM7812CT**  
**TA7815S**  
POSITIVE VOLTAGE REGULATOR

- FRONT VIEW -



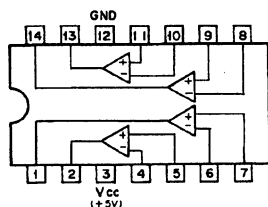
**LM7912CT**  
**NJM7912FA**  
NEGATIVE VOLTAGE REGULATOR

- FRONT VIEW -



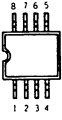
**LM339NS**  
QUAD COMPARATORS

- TOP VIEW -



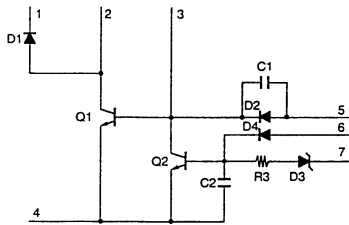
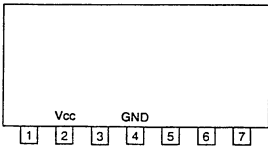
LTC485CS8  
TC7W32FU

- TOP VIEW -



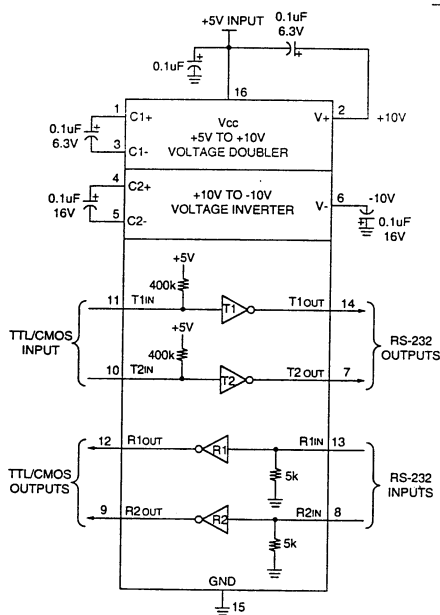
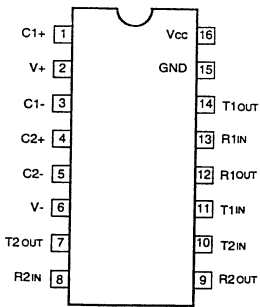
MA2820 (SHINDEN)  
POWER SUPPLY

- PRINTED SIDE VIEW -



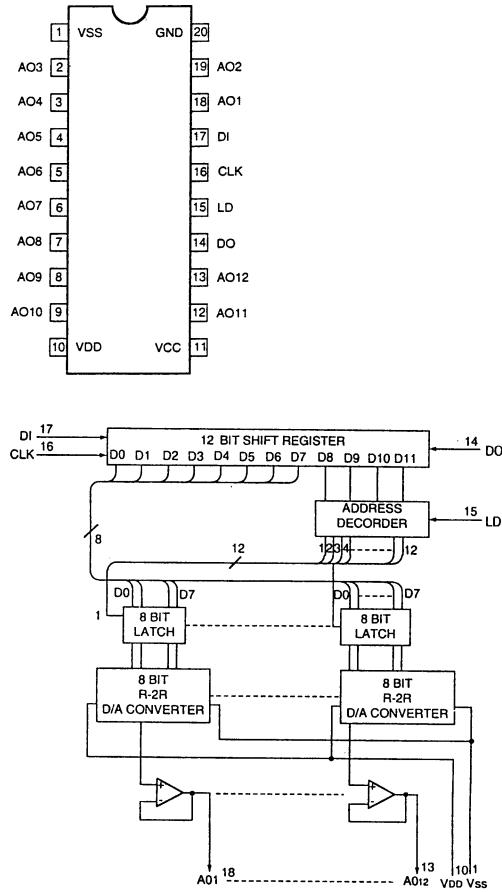
MAX202CS (MAXIM)  
C-MOS RS-232 TRANSMITTER/RECEIVER

- TOP VIEW -



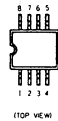
MB88346BPFV (FUJITSU)  
C-MOS D/A CONVERTER

- TOP VIEW -



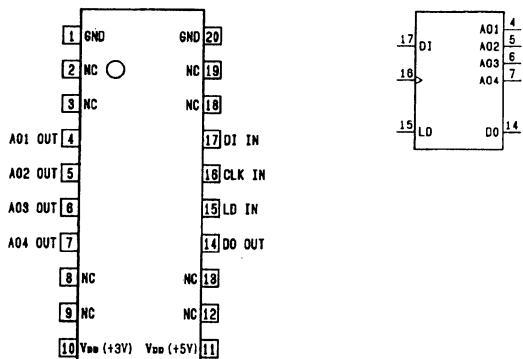
MAX877CSA

- TOP VIEW -



**MB88351PFV (FUJITSU) FLAT PACKAGE**  
C-MOS 12-BIT D/A CONVERTER WITH OPERATIONAL AMPLIFIER

- TOP VIEW -

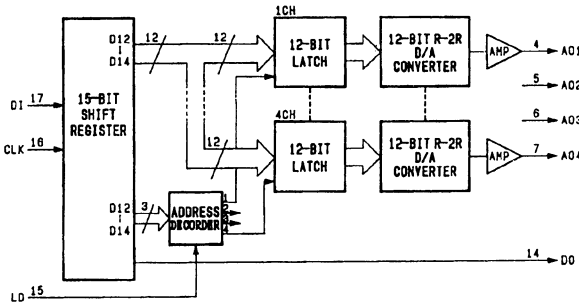


**INPUT**  
CLK : SHIFT CLOCK  
DI : SERIAL DATA  
LD : DECODER AND D/A REGISTER TO LOAD

**OUTPUT**  
AO1 - AO4 : ANALOG DATA  
DO : MBS BIT DATA IN 15-BIT SHIFT REGISTER

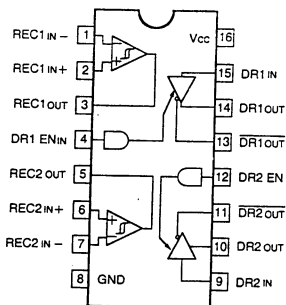
D12	D13	D14	ADDRESS SELECT
0	0	0	DON'T CARE
0	0	1	AO1 SELECT
0	1	0	AO2 SELECT
0	1	1	AO3 SELECT
1	0	0	AO4 SELECT
1	0	1	DON'T CARE
1	1	0	DON'T CARE
1	1	1	DON'T CARE

0 : LOW LEVEL  
1 : HIGH LEVEL



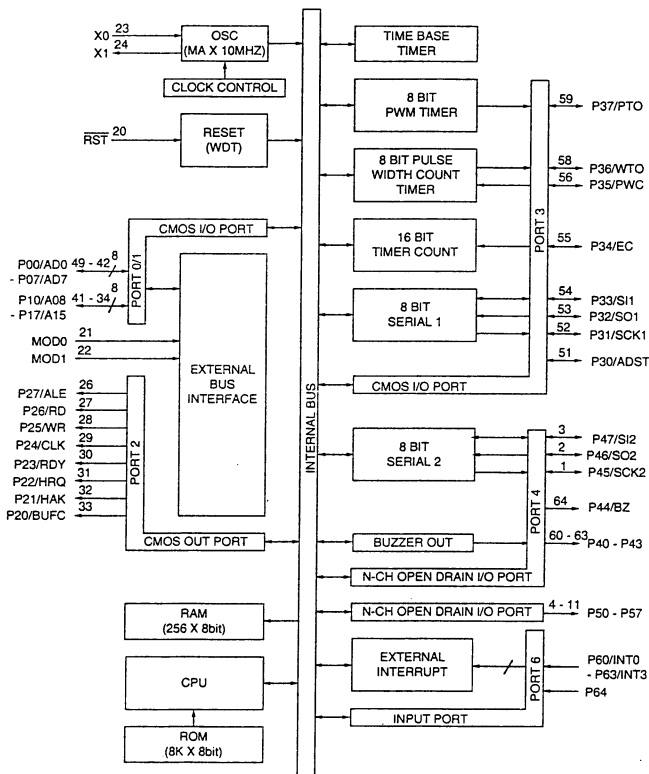
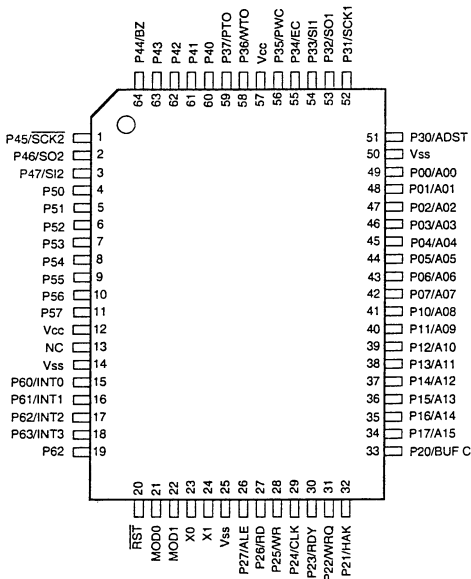
**MC34051MEL**  
RS-422 LINE DRIVER/RECEIVER

- TOP VIEW -



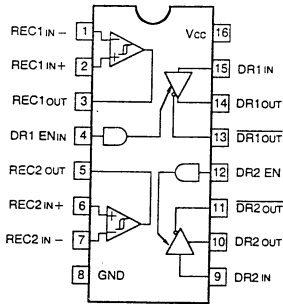
**MB89613PF (FUJITSU)**  
C-MOS 8 BIT ONE CHIP MICRO CONTROLLER

- TOP VIEW -



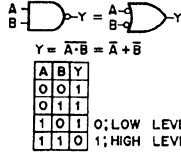
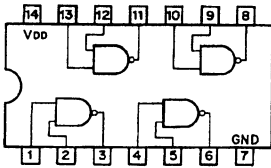
MC34051MEL  
RS-422 LINE DRIVER/RECEIVER

- TOP VIEW -



MC74HC02AF  
SN74HC02ANS  
C-MOS QUAD 2-INPUT NOR GATES

- TOP VIEW -

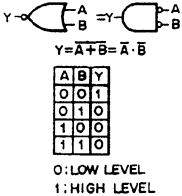
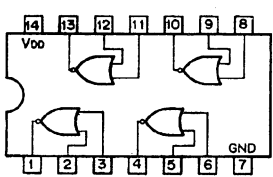


NOTE:

TYPE	V <sub>DD</sub>
TC74AC00 TYPE	+2 to +5.5V
TC74VHC00	+5V
MC74HC000	+4.5 to +5.5V
OTHER TYPES	+2 to +6V

MC74HC02AF  
SN74HC02ANS  
C-MOS QUAD 2-INPUT NOR GATES

- TOP VIEW -

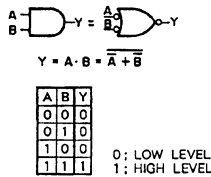
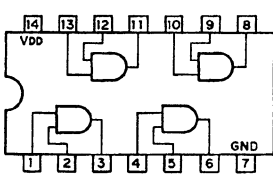


NOTE:

TYPE	V <sub>DD</sub>
HC	+2 to +6V
AC/VHC	+2 to +5.5V
HCT/ACT	+5V

MC74HC08AF  
C-MOS QUAD 2-INPUT AND GATES

- TOP VIEW -

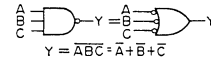
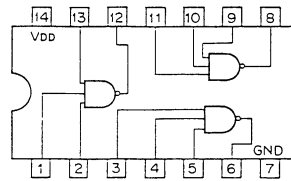


NOTE:

TYPE	V <sub>DD</sub>
TC74AC08 TYPE	+2 to +5.5V
MC74ACT08M	+2 to +8V
TC40H	+2 to +6V
OTHER TYPES	+2 to +6V

MC74HC10F  
C-MOS 3-INPUT NAND GATE

- TOP VIEW -



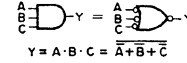
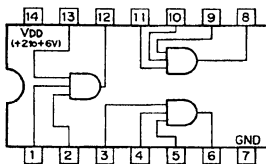
NOTE:

TYPE	V <sub>DD</sub>
TC40H	+2 to +8V
OTHERS	+2 to +6V

0: LOW LEVEL  
1: HIGH LEVEL

MC74HC11F  
C-MOS 3-INPUT POSITIVE-AND GATES

- TOP VIEW -



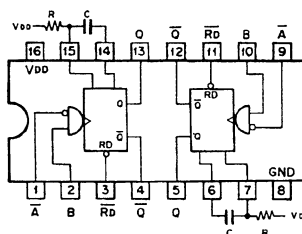
NOTE:

TYPE	V <sub>DD</sub>
TC74VHC11	+2V to +5.5V
OTHER TYPES	+2V to +6V

0: LOW LEVEL  
1: HIGH LEVEL

MC74HC123AF  
C-MOS DUAL RETRIGGERABLE MONOSTABLE MULTIVIBRATORS

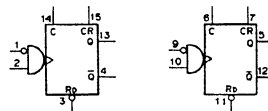
- TOP VIEW -



INPUT	OUTPUT			
RD	A	B	Q	Q-bar
0	X	X	0	1
1	1	X	0	1
1	X	0	0	1
1	0	1	1	0
1	1	1	1	0
1	0	1	1	0

0: LOW LEVEL  
1: HIGH LEVEL  
X: DON'T CARE

OUTPUT PULSE WIDTH = 0.46CR

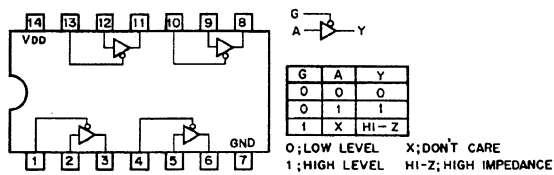


NOTE:

TYPE	V <sub>DD</sub>
TC74HCT123AF	+5V
OTHER TYPES	+2 to +6V

**MC74HC125AF**  
**TC74HC125AF**  
**C-MOS BUS BUFFER GATES WITH 3-STATE OUTPUT**

- TOP VIEW -

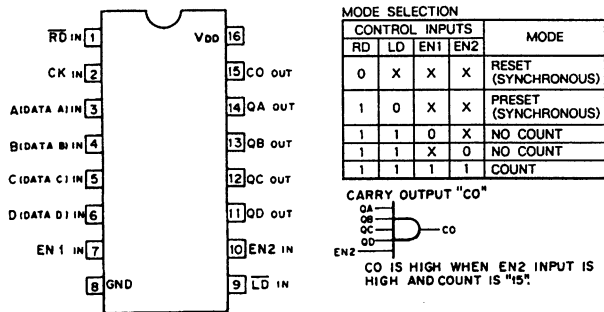


NOTE:

TYPE	V <sub>DD</sub>
AC HC	+2 to +6V
LVT	+2.7 to +3.6V

**MC74HC163AF**  
**C-MOS PRESETTABLE SYNCHRONOUS 4-BIT BINARY COUNTER**

- TOP VIEW -



NOTE:

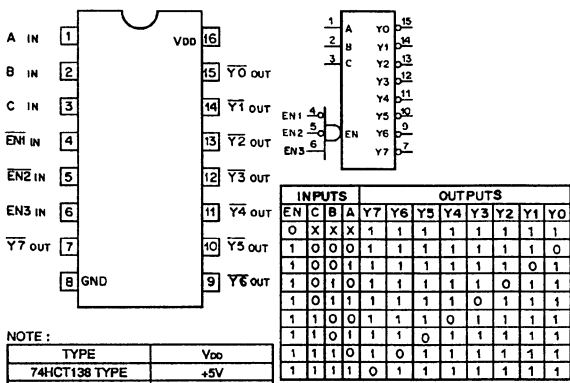
TYPE	V <sub>DD</sub>
HC	+2 to +6V
AC/VHC	+2 to +5.5V
HCT/ACT/FCT	+5V

COUNT SEQUENCE

COUNT	QD	QC	QB	QA
0	0	0	0	0
1	0	0	0	1
2	0	0	1	0
3	0	0	1	1
4	0	1	0	0
5	0	1	0	1
6	0	1	1	0
7	0	1	1	1
8	1	0	0	0
9	1	0	0	1
10	1	0	1	0
11	1	0	1	1
12	1	1	0	0
13	1	1	0	1
14	1	1	1	0
15	1	1	1	1

**MC74HC138AF**  
**C-MOS 3-TO-8 LINE DECODER/DEMULTIPLEXER**

- TOP VIEW -

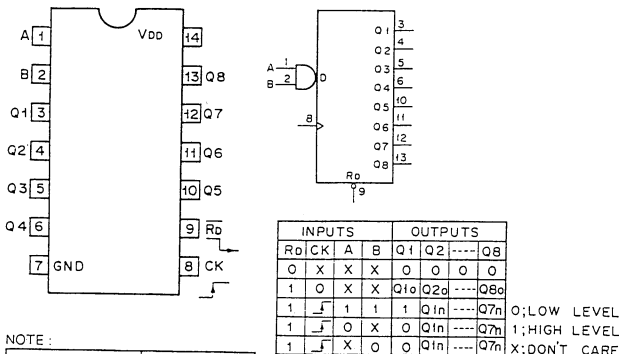


NOTE:

TYPE	V <sub>DD</sub>
74HCT138 TYPE	+5V
74ACT138 TYPE	+4.5 to +5.5V
TC74AC138 TYPE	+2 to +5.5V
TC74VHC138	+2 to +5.5V
OTHER TYPES	+2 to +6V

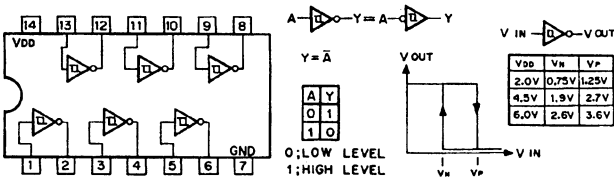
**MC74HC164FL**  
**C-MOS 8-BIT SERIAL-IN/PARALLEL-OUT SHIFT REGISTER**

- TOP VIEW -



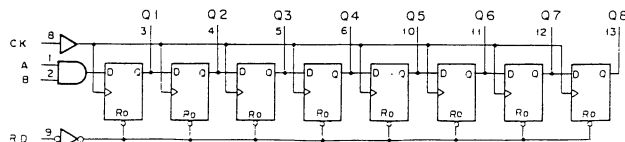
**MC74HC14AF**  
**C-MOS HEX SCHMITT TRIGGER INVERTERES**

- TOP VIEW -



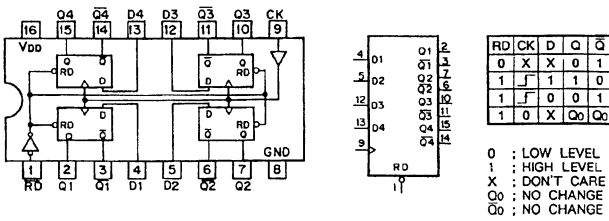
NOTE:

TYPE	V <sub>DD</sub>
TC74AC/VHC	+2 to +5.5V
OTHER TYPES	+2 to +6V



**MC74HC175F**  
C-MOS QUAD D-TYPE FLIP-FLOPS WITH RESET

- TOP VIEW -

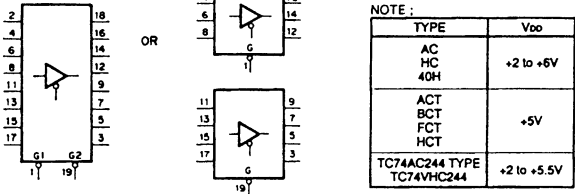
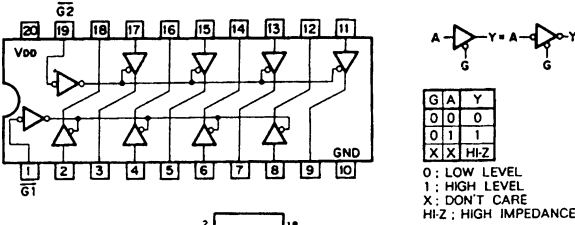


NOTE:

TYPE	V <sub>DD</sub>
ACT TYPE	+2 to +5.5 V
74ACT175 TYPE	+4.5V to 5.5 V
OTHER TYPES	+2 to +6 V

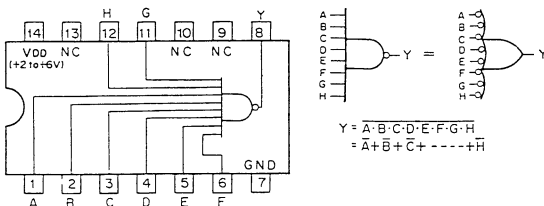
**MC74HC244AF**  
C-MOS BUS BUFFER WITH 3-STATE OUTPUTS

- TOP VIEW -



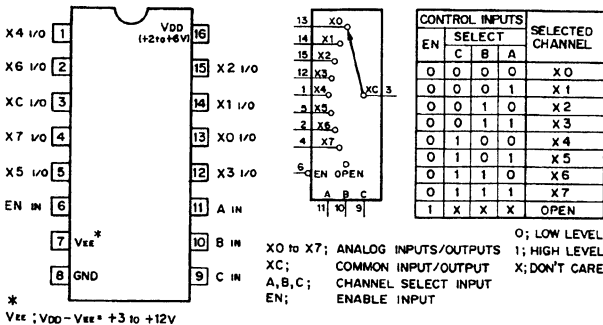
**MC74HC30F**  
C-MOS 8-INPUT POSITIVE-NAND GATE

- TOP VIEW -



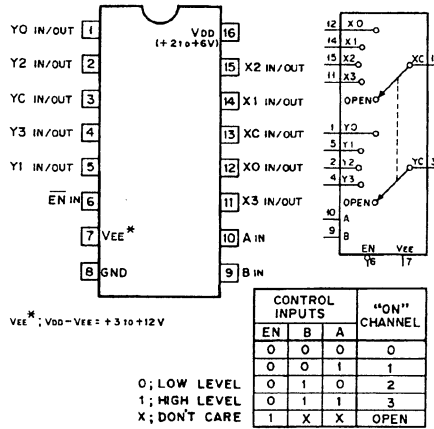
**MC74HC4051F**  
C-MOS DUAL 8-CHANNEL ANALOG MULTIPLEXER/DEMULTIPLEXER

- TOP VIEW -



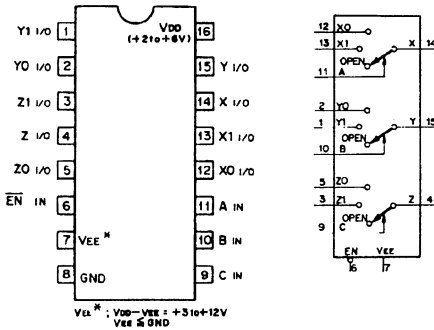
**MC74HC4052F**  
C-MOS DUAL 4-CHANNEL ANALOG MULTIPLEXER/DEMULTIPLEXER

- TOP VIEW -



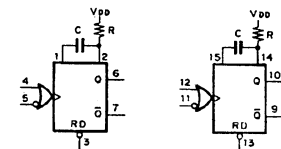
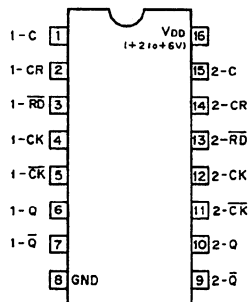
**MC74HC4053F (MOTOROLA) FLAT PACKAGE**  
C-MOS TRIPLE 2-CHANNEL ANALOG MULTIPLEXER/DEMULTIPLEXER

- TOP VIEW -

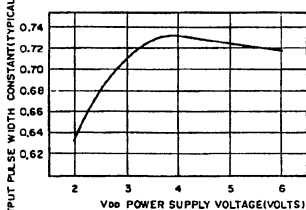


**MC74HC4538AF**  
C-MOS DUAL RETRIGGERABLE/NON-RETRIGGERABLE MONOSTABLE MULTIVIBRATOR

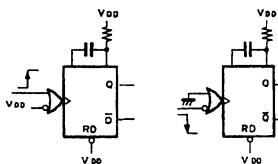
- TOP VIEW -



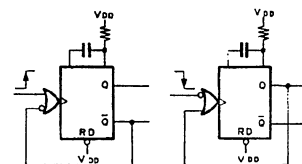
OUTPUT PULSE WIDTH = k · C · R



RETRIGGERABLE M.M.V

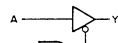
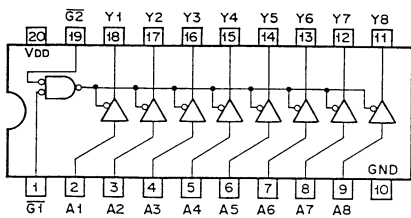


NON-RETRIGGERABLE M.M.V



**MC74HC541AFEL (MOTOROLA) FLAT PACKAGE**  
C-MOS BUFFER S AND LINE D

- TOP VIEW -

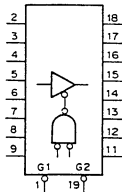


G1	G2	A	Y
0	0	0	0
0	0	1	1
1	X	X	HI-Z
X	1	X	HI-Z

0; LOW LEVEL  
1; HIGH LEVEL  
X; DON'T CARE  
HI-Z; HIGH IMPEDANCE

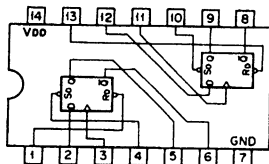
NOTE:

TYPE	VDD
AC/VHC	+2 to +5.5V
HC	+2 to +6V
ABT/ACT/BCT/HCT	+5V



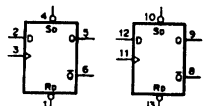
**MC74HC74AF**  
C-MOS DUAL D-TYPE FLIP-FLOPS WITH DIRECT SET/RESET

- TOP VIEW -



INPUTS	OUTPUTS
5S RD CK D	Qn+1 Qn+1-bar
0 1 X X	1 0
1 0 X X	0 1
0 0 X X	1 1
1 1 J J	1 1
1 1 J J	0 0
1 1 0 X	Qn Qn

0; LOW LEVEL  
1; HIGH LEVEL  
X; DON'T CARE

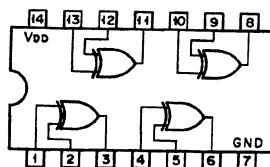


NOTE:

TYPE	VDD
HCT/ACT	+5V
TC74AC/VHC	+2 to +5.5V
OTHERS	+2 to +6V

**MC74HC86F**  
C-MOS QUAD EXCLUSIVE OR GATES

- TOP VIEW -



$Y = \bar{A}B + A\bar{B}$

A	B	Y
0	0	0
0	1	1
1	0	1
1	1	0

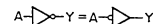
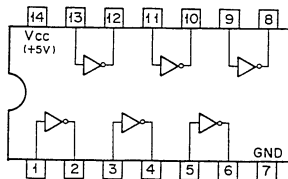
0; LOW LEVEL  
1; HIGH LEVEL

NOTE:

TYPE	VDD
TC74AC/VHC	+2 to +5.5V
TC74HCT	+5V
OTHER TYPES	+2 to +6V

**MC74HC04F (MOTOROLA) FLAT PACKAGE**  
TTL INVERTER

- TOP VIEW -



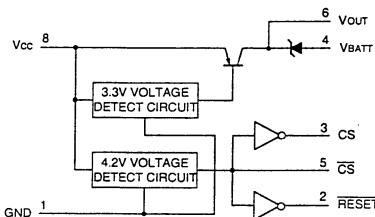
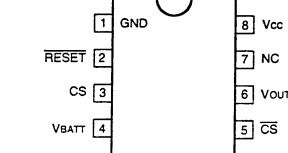
$Y = \bar{A}$

A	Y
0	1
1	0

0; LOW LEVEL  
1; HIGH LEVEL

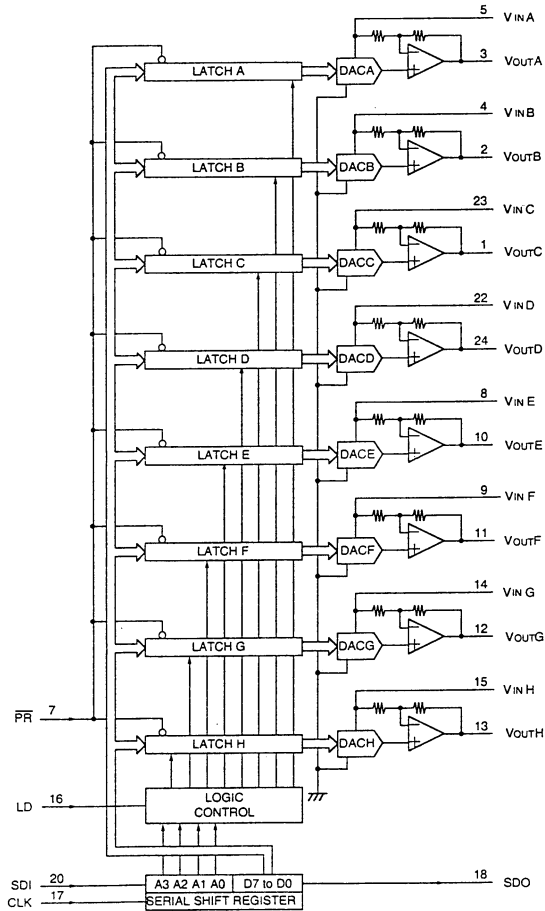
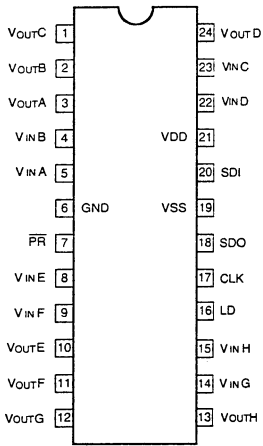
**MM1026BFB**  
SYSTEM RESET

- TOP VIEW -



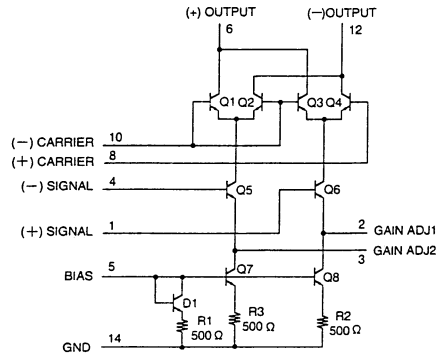
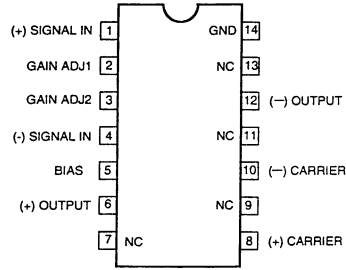
**MP7670AS (MICRO POWER SYSTEMS)  
C-MOS 8 BIT 8 CHANNEL D/A CONVERTER**

- TOP VIEW -



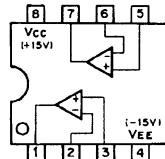
**NJM1496M  
DOUBLE BALANCED MODULATOR/DEMODULATOR**

- TOP VIEW -

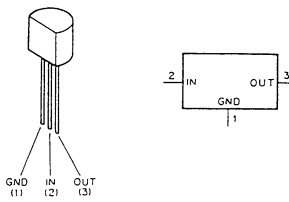


**NJM4558M  
DUAL OPERATIONAL AMPLIFIER**

- TOP VIEW -

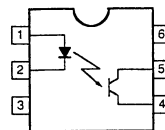


**NJM79L05A (JRC) -5V (100mA)  
NEGATIVE VOLTAGE REGULATOR**



**PC111YS (SHARP)  
DETECTOR**

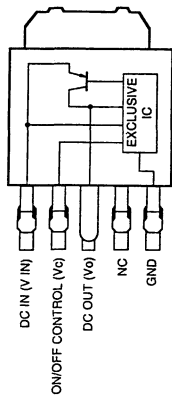
- TOP VIEW -





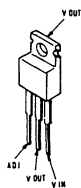
**PQ12TZ5N**  
SERVOES REGULATOR

- SIDE VIEW -



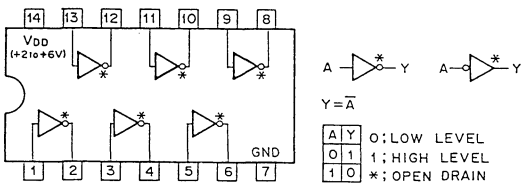
**SE005N**

- TOP VIEW -



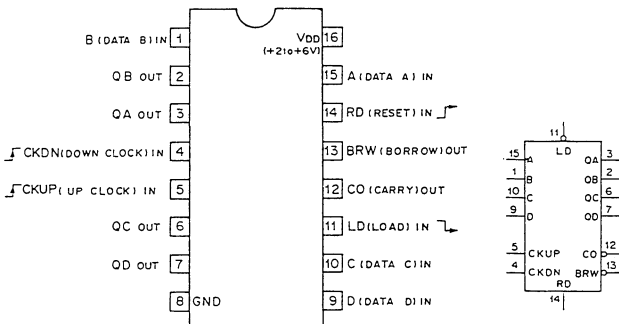
**SN74HC05ANS (TI) FLAT PACKAGE**  
C-MOS HEX INVERTER WITH OPEN-DRAIN

- TOP VIEW -



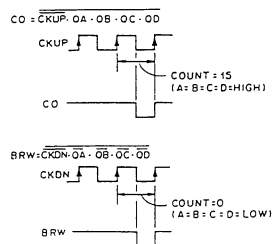
**SN74HC193ANS (TI) FLAT PACKAGE**  
C-MOS PRESETTABLE SYNCHRONOUS 4-BIT UP/DOWN COUNTER

- TOP VIEW -



CONTROL INPUT				MODE
RD	LD	CKUP/CKDN	CKON	
1	X	X	X	RESET TO ZERO
0	0	X	X	PRESET
0	1	$\bar{1}$	1	UP COUNT
0	1	1	$\bar{1}$	DOWN COUNT
0	1	1	1	NO COUNT

COUNT	OUTPUT			
	OD	OC	OB	OA
0	0	0	0	0
1	0	0	0	1
2	0	0	1	0
3	0	0	1	1
4	0	1	0	0
5	0	1	0	1
6	0	1	1	0
7	0	1	1	1
8	1	0	0	0
9	1	0	0	1
10	1	0	1	0
11	1	0	1	1
12	1	1	0	0
13	1	1	0	1
14	1	1	1	0
15	1	1	1	1

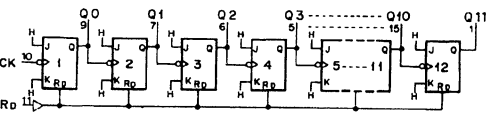
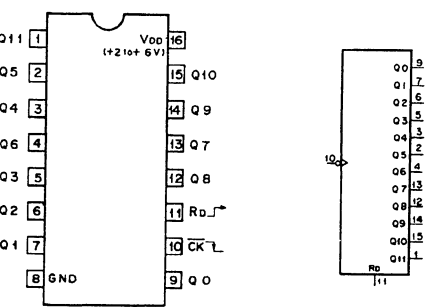


0; LOW LEVEL  
1; HIGH LEVEL  
X; DON'T CARE

**SN74HC400ANS (TI) FLAT PACKAGE**  
C-MOS 12-STAGE RIPPLE CARRY BINARY COUNTER/DRIVER

**SN74HC400ANS (TI) FLAT PACKAGE**  
C-MOS 12-STAGE RIPPLE CARRY BINARY COUNTER/DRIVER

- TOP VIEW -

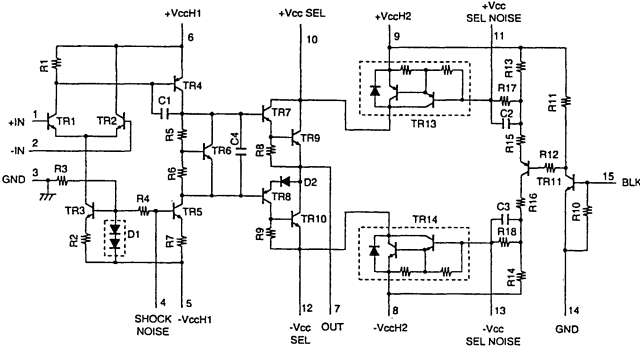
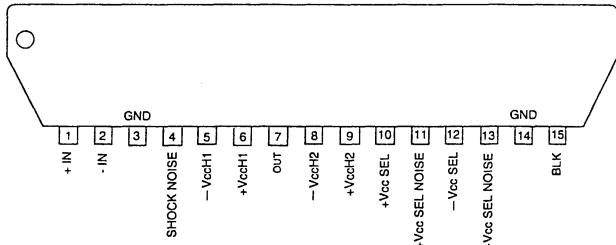


COUNT	Q11	Q10	Q9	Q8	Q7	Q6	Q5	Q4	Q3	Q2	Q1	Q0	RD	Q11.....Q0
0	0	0	0	0	0	0	0	0	0	0	0	0	1	ALL LOW
1	0	0	0	0	0	0	0	0	0	0	0	1	0	COUNT
2	0	0	0	0	0	0	0	0	0	0	1	0		
3	0	0	0	0	0	0	0	0	0	0	1	1		
...	...	...	...	...	...	...	...	...	...	...	...	...		
4095	1	1	1	1	1	1	1	1	1	1	1	1		

0; LOW LEVEL  
1; HIGH LEVEL

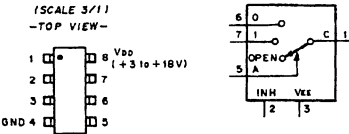
STK390-120 (SANYO)  
POWER AMPLIFIER

- SIDE VIEW -



TC4W53FU (TOSHIBA) CHIP PACKAGE  
C-MOS 2-CHANNEL MULTIPLEXER/DEMUTIPLEXER

- TOP VIEW -

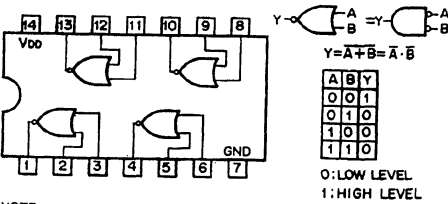


CONT. INPUT		ON CHANNEL
INH	A	0
0	0	0
0	1	1
1	X	OPEN

0: LOW LEVEL  
1: HIGH LEVEL  
X: DON'T CARE

TC74HC02AF  
C-MOS QUAD 2-INPUT NOR GATES

- TOP VIEW -

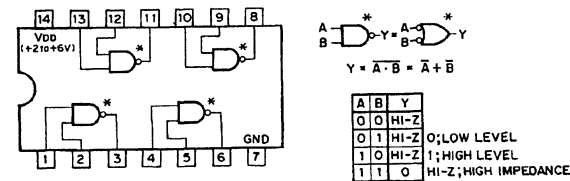


NOTE:

TYPE	V <sub>DD</sub>
HC	+2 to +6V
AC/VHC	+2 to +5.5V
HCT/ACT	+5V

TC74HC03AF  
C-MOS 2-INPUT POSITIVE-NAND GATE WITH OPEN-DRAIN

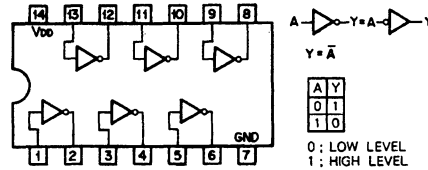
- TOP VIEW -



0: LOW LEVEL  
1: HIGH LEVEL  
HI-Z: HIGH IMPEDANCE

TC74HC04AF  
C-MOS HEX INVERTERS

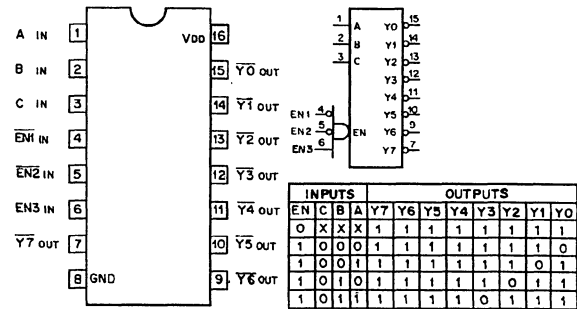
- TOP VIEW -



NOTE:

TYPE	V <sub>DD</sub>
74HCT04 TYPE	+5V
TC74AC04 TYPE TC74VHC04 TYPE	+2 to +5.5V
74ACT04 TYPE	+4.5 to +5.5V
OTHER TYPES	+2 to +6V

TC74HC138AF  
C-MOS 3-TO-8 LINE DECODER/DEMUTIPLEXER



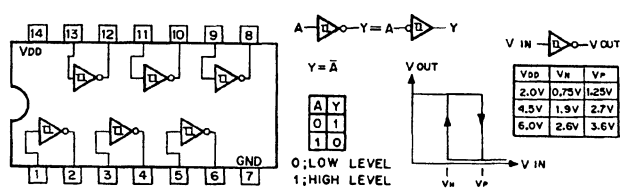
NOTE:

TYPE	V <sub>DD</sub>
74HCT138 TYPE	+5V
74ACT138 TYPE	+4.5 to +5.5V
TC74AC138 TYPE TC74VHC138	+2 to +5.5V
OTHER TYPES	+2 to +6V

EN = EN1 · EN2 · EN3  
0: LOW LEVEL  
1: HIGH LEVEL  
X: DON'T CARE

TC74HC14AF  
C-MOS HEX SCHMITT TRIGGER INVERTERS

- TOP VIEW -

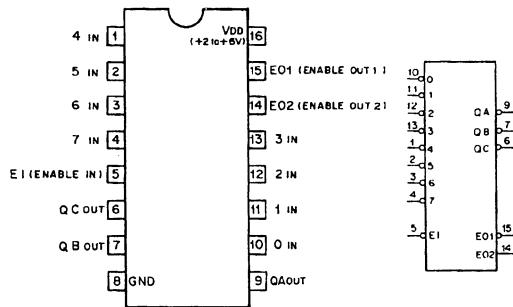


NOTE:

TYPE	V <sub>DD</sub>
TC74AC/MHC	+2 to +5.5V
OTHER TYPES	+2 to +6V

**TC74HC148AF**  
C-MOS 8-TO-3-LINE PRIORITY ENCODER

- TOP VIEW -

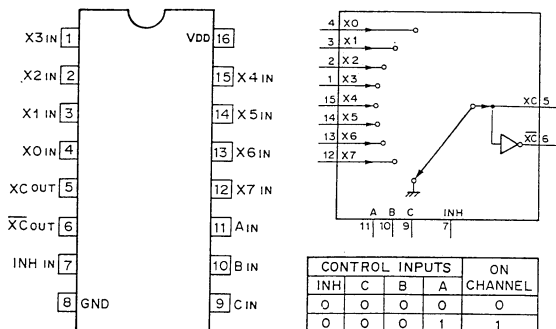


INPUTS								OUTPUTS					
E1	7	6	5	4	3	2	1	0	QC	QB	QA	E01	E02
1	X	X	X	X	X	X	X	X	1	1	1	1	1
0	1	1	1	1	1	1	1	1	1	1	1	0	1
0	1	1	1	1	1	1	1	0	1	1	1	1	0
0	1	1	1	1	1	1	0	X	1	1	0	1	0
0	1	1	1	1	1	0	X	X	1	0	1	1	0
0	1	1	1	1	0	X	X	X	1	0	0	1	0
0	1	1	1	0	X	X	X	X	0	1	1	1	0
0	1	1	0	X	X	X	X	X	0	1	0	1	0
0	1	0	X	X	X	X	X	X	0	0	1	1	0
0	0	X	X	X	X	X	X	X	0	0	0	1	0

0; LOW LEVEL 1; HIGH LEVEL X; DON'T CARE

**TC74HC151AF (MOTOROLA) FLAT PACKAGE**  
C-MOS 8-LINE-TO-1-LINE DATA SELECTOR/MULTIPLEXER

- TOP VIEW -



CONTROL INPUTS				ON CHANNEL
INH	C	B	A	
0	0	0	0	0
0	0	0	1	1
0	0	1	0	2
0	0	1	1	3
0	1	0	0	4
0	1	0	1	5
0	1	1	0	6
0	1	1	1	7
1	X	X	X	GND

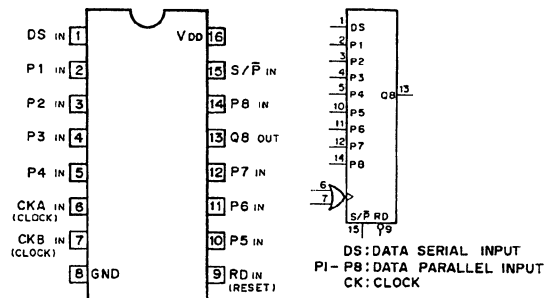
0; LOW LEVEL 1; HIGH LEVEL X; DON'T CARE

NOTE:

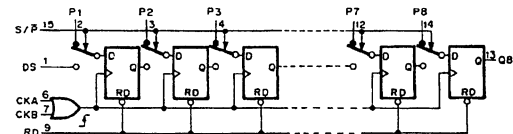
TYPE	V <sub>DD</sub>
HC	+2 to +6V
AC/VHC	+2 to +5.5V
HCT/ACT/FCT	+5V

**TC74HC166AF**  
C-MOS 8-BIT SHIFT REGISTER

- TOP VIEW -



DS: DATA SERIAL INPUT  
P1 - P8: DATA PARALLEL INPUT  
CK: CLOCK



CKA CKB CK			INPUT				OUTPUT	
0	0	0	RD	S/P	CK	DS	P1-P8	Q8
X	1	1	0	X	X	X	X	0
1	X	1	1	X	0	X	X	Q8c
1	1	1	1	0	X	X	1-8	8
1	1	1	1	1	1	X	1	Q7n
0	1	1	1	1	0	X	1	Q7n
1	X	1	1	X	X	X	X	Q8c

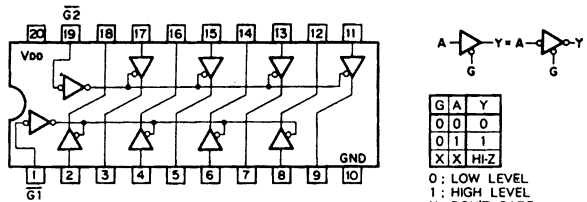
NOTE:

TYPE	V <sub>DD</sub>
TC40H	+2 to +8V
OTHERS	+2 to +6V

0; LOW LEVEL 1; HIGH LEVEL X; DON'T CARE

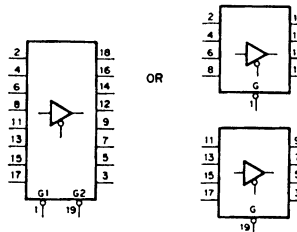
**TC74HC244AF**  
C-MOS BUS BUFFER WITH 3-STATE OUTPUTS

- TOP VIEW -



G	A	Y
0	0	0
0	1	1
X	X	Hi-Z

0; LOW LEVEL 1; HIGH LEVEL X; DON'T CARE Hi-Z; HIGH IMPEDANCE

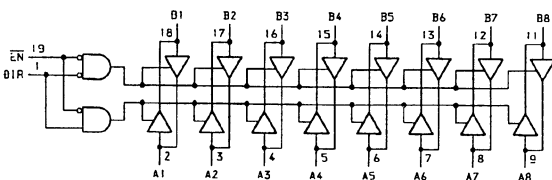
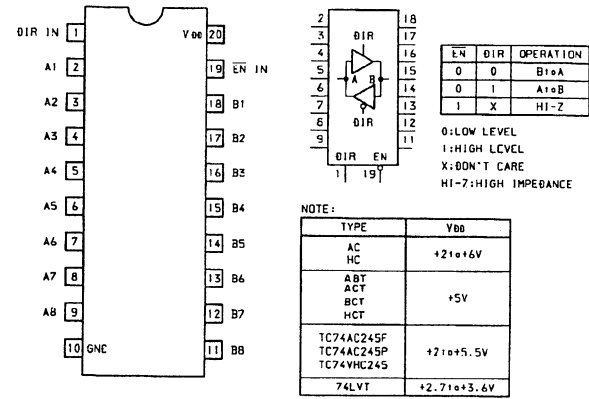


NOTE:

TYPE	V <sub>DD</sub>
AC HC 40H	+2 to +6V
ACT BCT FCT HCT	+5V
TC74AC244 TYPE TC74VHC244	+2 to +5.5V

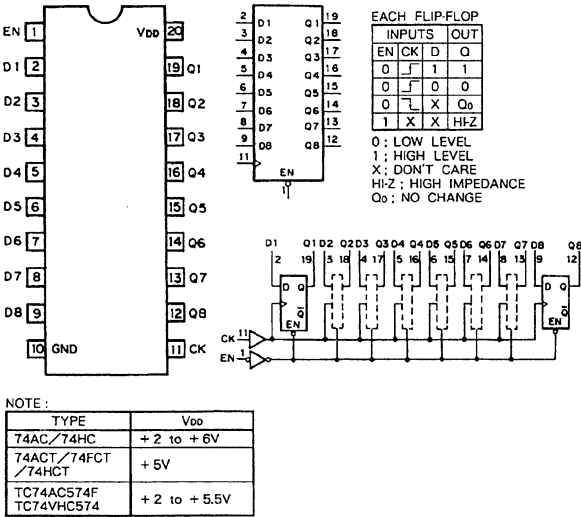
TC74HC245AF  
C-MOS BILATERAL BUS TRANSCEIVERS WITH 3-STATE OUTPUTS

- TOP VIEW -

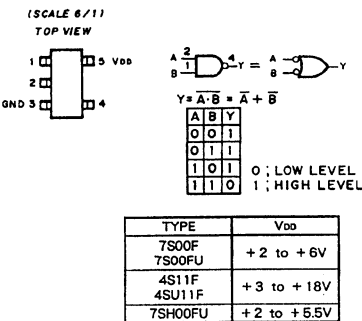


TC74HC574AF  
C-MOS 3-STATE D-TYPE EDGE-TRIGGERED FLIP-FLOP

- TOP VIEW -

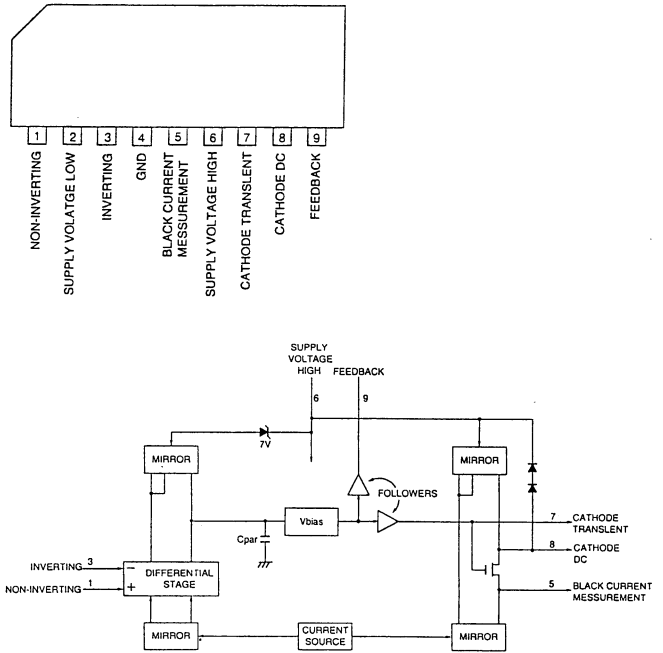


TC7S00FU  
TC7S02FU  
TC7S32FU  
C-MOS 2-INPUT NAND GATE



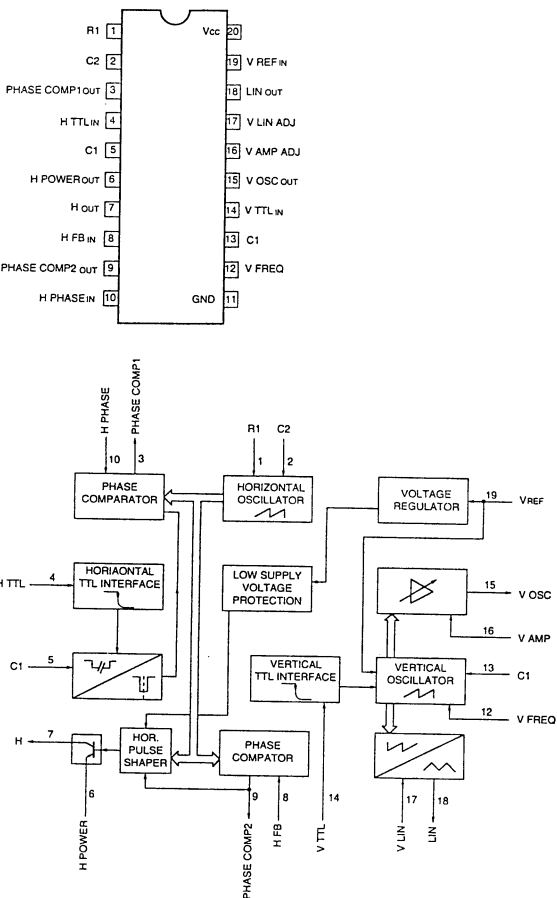
TDA6101Q (PHILIPS)  
TDA6111Q (PHILIPS)  
VIDEO OUTPUT AMPLIFIER

- LATTER SIDE -



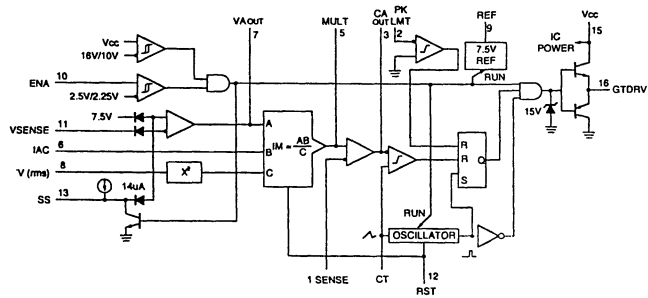
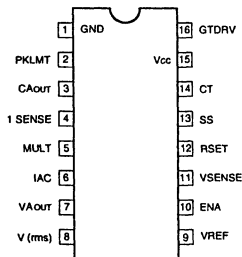
TDA9102C (SGS)  
H/V PROCESSOR

- TOP VIEW -



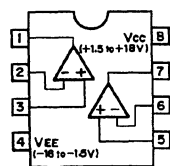
**TK83854D**  
SWITCHING POWER MODULE

- TOP VIEW -

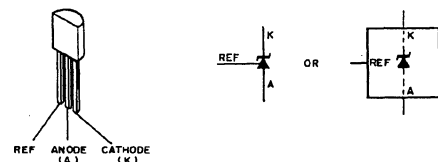


**TL082CPS (TI)**  
OPERATIONAL AMPLIFIER (J FET INPUT)

- TOP VIEW -

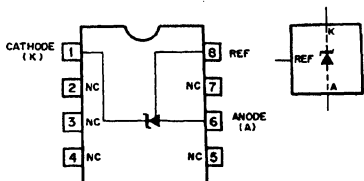


**TL431CLP (TI) FLAT PACKAGE**  
ADJUSTABLE PRECISION SHUNT REGULATOR



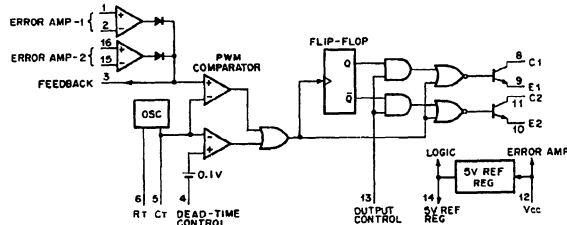
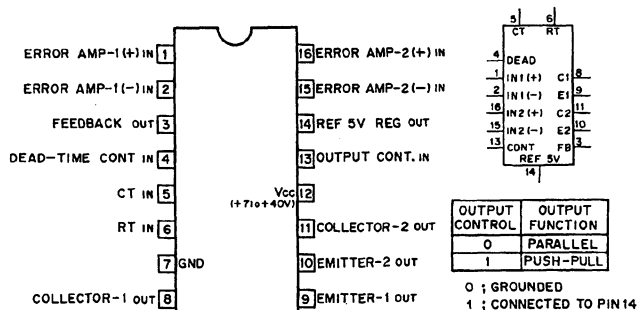
**TL431CPS (TI) FLAT PACKAGE**  
ADJUSTABLE PRECISION SHUNT REGULATOR

- TOP VIEW -



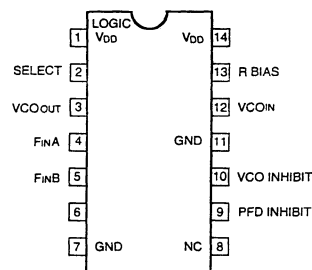
**TL494CNS (TI)**  
PWM POWER CONTROL

- TOP VIEW -



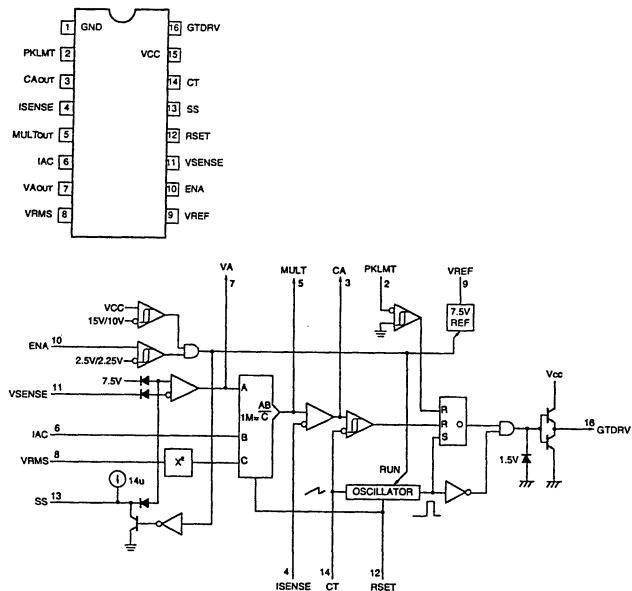
**TLC2932IPW**  
C-MOS PHASE LOCKED LOOP

- TOP VIEW -



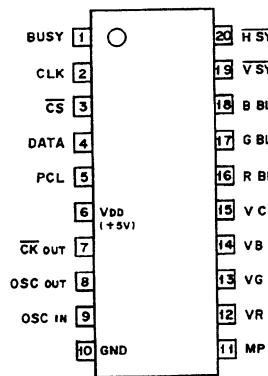
**UC3854N (UNITRODE)**  
HIGH POWER FACTOR PREREGULATOR

- TOP VIEW -



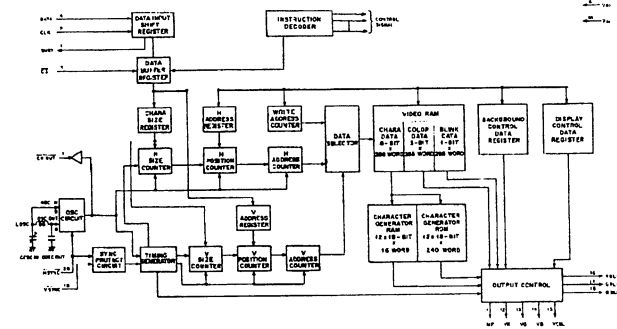
**μPD6453GT (NEC) FLAT PACKAGE  
C-MOS ON-SCREEN CHARACTER DISPLAY**

- TOP VIEW -



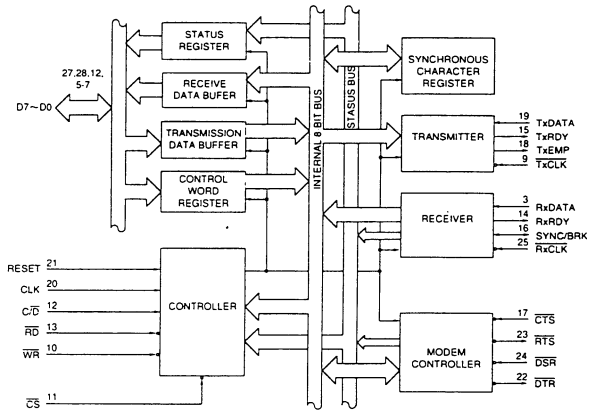
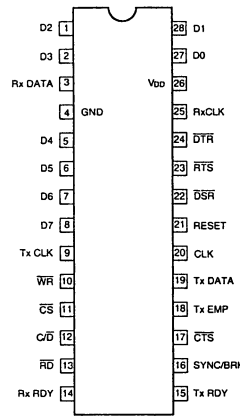
**INPUT**  
 CLK : CLOCK  
 CS : CHIP SELECT  
 DATA : SERIAL DATA  
 H SYNC : HORIZONTAL SYNC  
 OSC IN : OSCILLATOR IN  
 PCL : POWER ON CLEAR  
 V SYNC : VERTICAL SYNC

**OUTPUT**  
 BBLK, RBLK, GBLK : B, R, G, BLANKING  
 BUSY : BUSY OUT  
 CK OUT : CLOCK  
 MP : MASK PULSE  
 OSC OUT : OSCILLATOR OUT  
 VR, VG, VB : R, G, B, CHARACTER DATA  
 VCBL : VIDEO CUT BLANKING



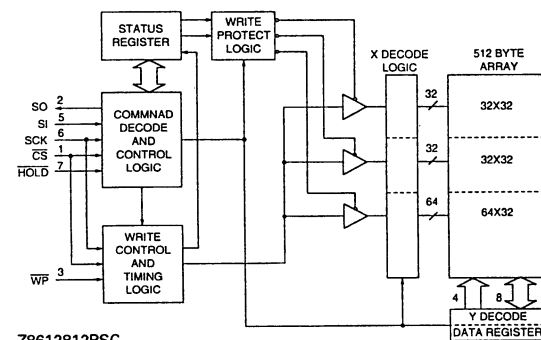
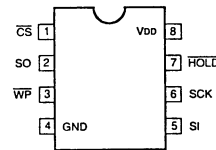
**μPD71051GU  
SERIAL CONTROL UNIT**

- TOP VIEW -



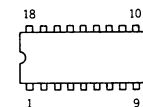
**X25040S (XICOR)  
C-MOS 4096 BIT SERIAL EEPROM**


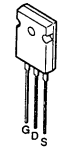
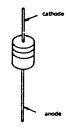
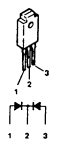

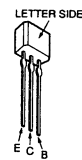
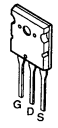


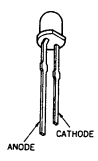

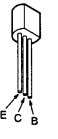
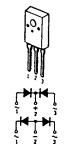

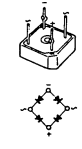
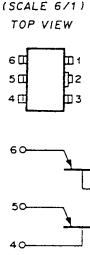


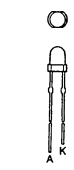
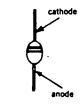
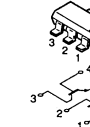
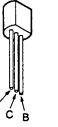

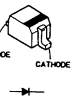

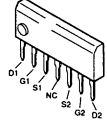
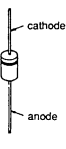
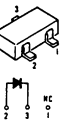
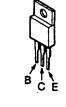





- TOP VIEW -



**Z8612812PSC**

- TOP VIEW -



	DTA144EKA DTC144EKA 2SA1037K 2SA1462 2SC1654 2SC2412K 2SC3545 2SC4213A 2SK520		IRFPG50LE		D1NS4 EGP10G RD10ES-B2 RD12ES-B RD15ES-B3 RD18ES-B2 RD3.9ES-B RD6.2ES-B RD7.5ES-B RD9.1ES-B 1SS119		ESAC39M-06C		EC1-QS04 SC311-6
	DTA144ESA 2SA1175 2SC2785		IRFP450LF		D10SC6M D8LCA20		ESAC39M-06N		SEL6210S SEL6410E
	DTC144ESA 2SC2668		2SA1208S 2SC1890A 2SC2362KG 2SC2878A 2SC3622-M		D10SC6MR		CL-155Y/PG-CD		S5VB60
	IMT2		2SA1221 2SB734-3 2SB734-34 2SC3209LK 2SD774-34		D5L60		LR002-01 SEL6910D		V11N V19C V19E
	IMX2		2SA893A		D8LCA20R		MA210 RD5.6S-B RD6.2SB RD6.2SB2 1SS352		
	IMZ1		2SC4686A 2SC4927		EPG10D ERC91-02 RH1AV1		RD12M-B1 RD12M-B2 RD18M-B2 RD22M RD22M-B3 RD3.0M-B RD3.3M-B1 RD5.6M-B RD5.6M-B2 RD6.8M-B1 RD6.8M-B3		
	IRFI9630GS 2SB860 2SD1137 2SD1138-C		2SD1834		ERB91-02 HZT33-02 1SS83TA		RD5.6S-B2		
			2SK160		ERD38-06				

1. anode 3. GND 5. V<sub>CE</sub>  
2. cathode 4. V<sub>BE</sub> 6. V<sub>CE</sub>





## SECTION 6 EXPLODED VIEWS

### NOTE :

- Items with no part number and no description are not stocked because they are seldom required for routine service.
- The construction parts of an assembled part are indicated with a collation number in the remarks column.
- Items marked " \* " are not stocked since they are seldom required for routine service. Some delay should be anticipated when ordering these items.

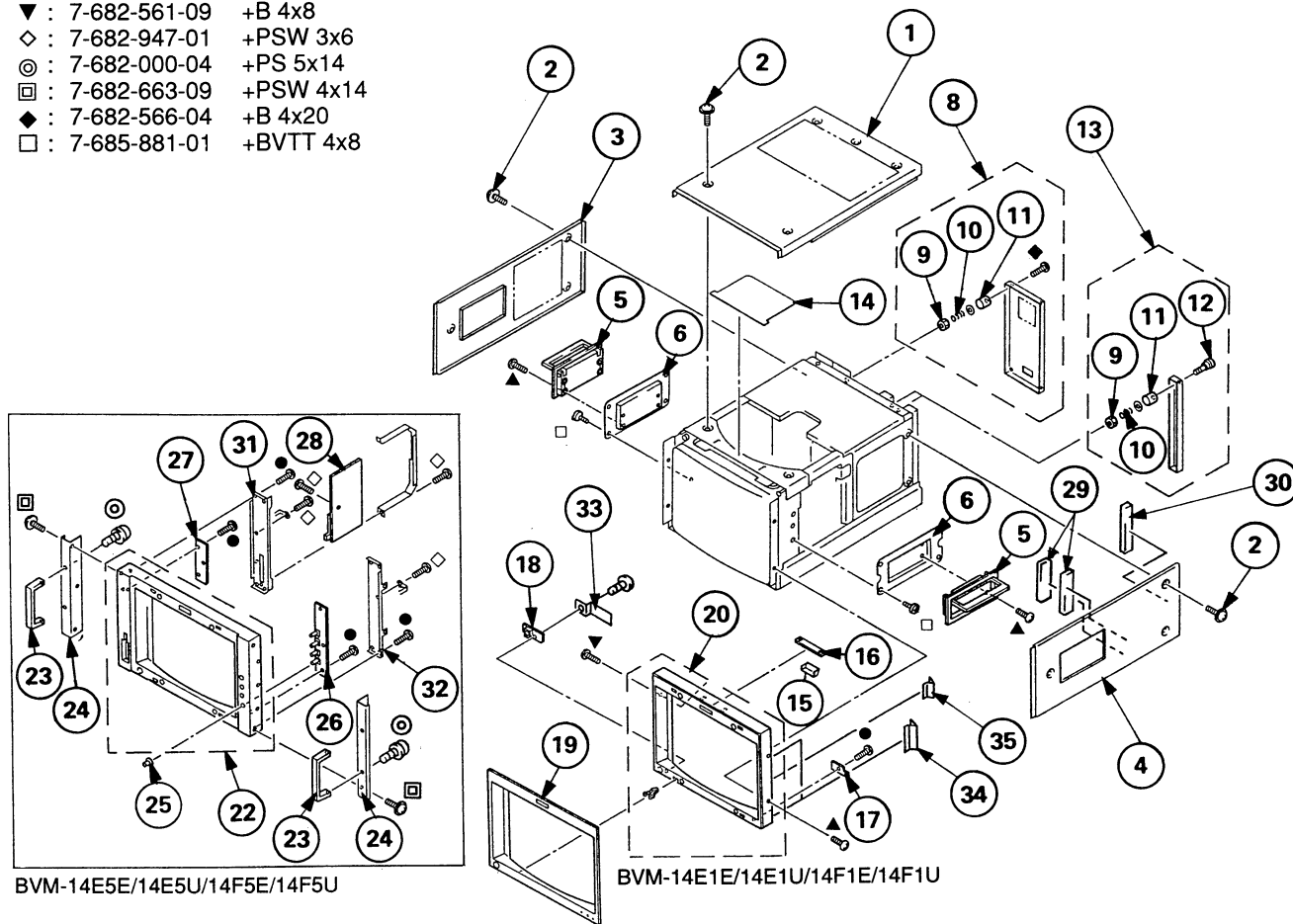
The components identified by shading and marked  $\Delta$  are critical for safety. Replace only with part number specified.

Les composants identifiés par une trame et une marque  $\Delta$  sont critiques pour la sécurité. Ne les remplacer que par une pièce portant le numéro spécifié.

### 6-1. COVER

#### (BVM-14E1E/14E1U/14E5E/14E5U/14F1E/14F1U/14F5E/14F5U)

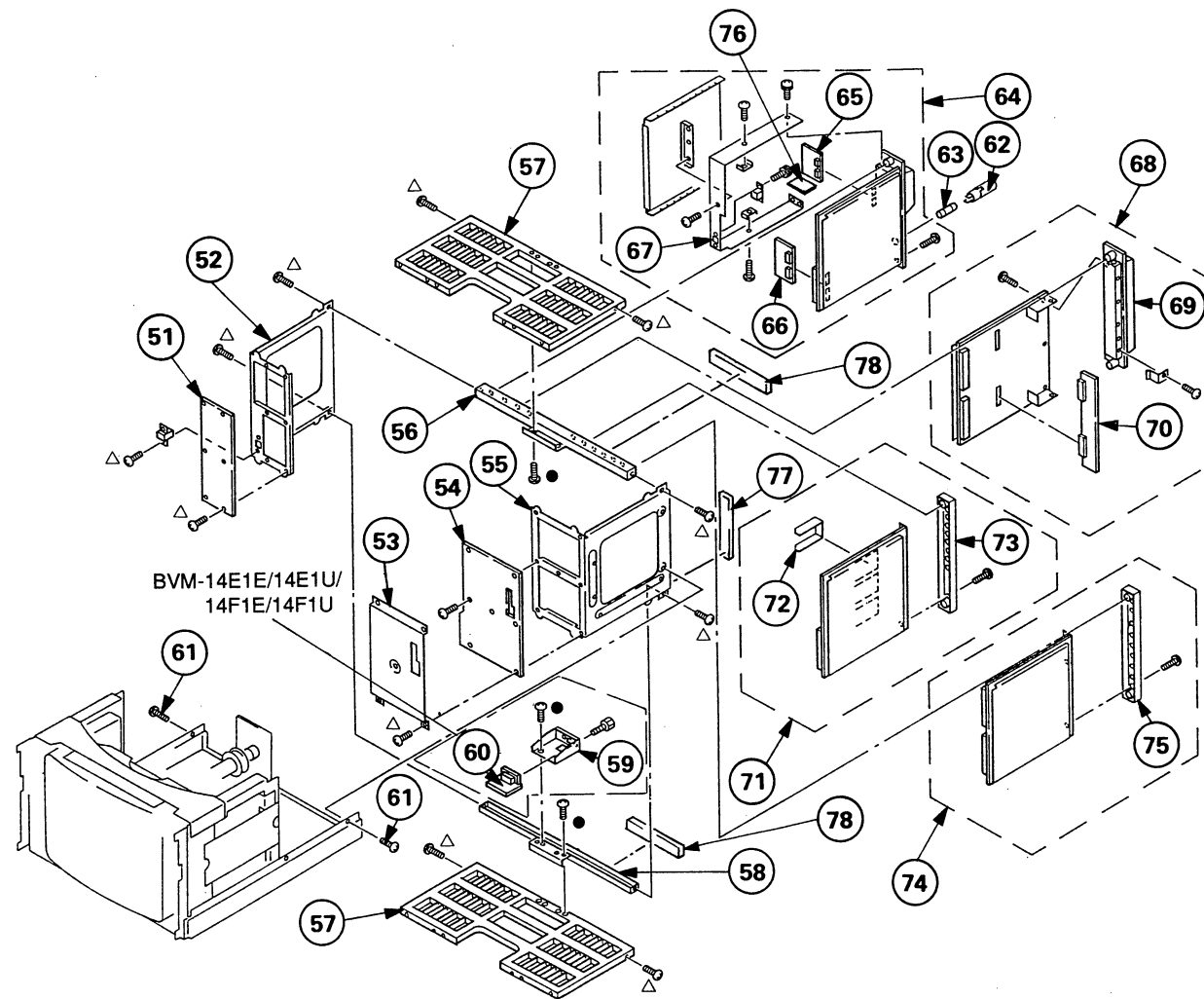
- : 7-685-648-79 +BVTP 3x12
- ▲ : 7-682-547-09 +P 3x6
- ▼ : 7-682-561-09 +B 4x8
- ◇ : 7-682-947-01 +PSW 3x6
- ◎ : 7-682-000-04 +PS 5x14
- : 7-682-663-09 +PSW 4x14
- ◆ : 7-682-566-04 +B 4x20
- : 7-685-881-01 +BVTT 4x8



REF NO.	PART NO.	DESCRIPTION	REMARK
1	4-050-931-01	CABINET (UPPER) (14E5E/14E5U/14F5E/14F5U)	
1	4-050-967-01	CABINET (UPPER) (14E1E/14E1U/14F1E/14F1U)	
2	4-847-802-11	SCREW (OS), CASE, CLAW	
3	4-050-933-01	CABINET (LEFT)	
4	4-050-932-01	CABINET (RIGHT)	
5	X-3642-018-3	HANDLE ASSY	
6	* 4-050-928-01	BRACKET, HANDLE	
8	* X-4033-110-2	PANEL ASSY, REAR (14E5E/14E5U/14F5E/14F5U)	9-11
8	* X-4033-144-1	PANEL ASSY, REAR (14E1E/14E1U/14F1E/14F1U)	9-11
9	* 3-648-057-01	NUT (ISO-4), U	
10	* 4-403-012-01	SPRING, STOPPER	
11	* 4-050-795-01	SPACER, REAR PANEL	
12	* 4-050-804-01	SCREW, PANEL STOPPER	
13	* X-4033-104-1	PANEL ASSY, BLANK	9-12
14	* 4-050-913-01	INSULATOR (ANODE)	
15	* 4-050-876-02	PLATE, LIGHT INTERCEPTION	
16	* A-1373-542-A	MOUNTED PCB, YA	
17	* A-1373-543-A	MOUNTED PCB, YB	
18	* A-1373-525-A	MOUNTED PCB, YC	
19	X-4033-128-1	MASK (4:3) ASSY	
20	X-4033-145-2	BEZEL ASSY (14E1E/14E1U/14F1E/14F1U)	
22	X-4033-130-3	BEZEL ASSY (14E5E/14E5U/14F5E/14F5U)	
23	4-337-212-12	HANDLE (14E5E/14E5U/14F5E/14F5U)	
24	4-050-922-01	BASE, HANDLE (14E5E/14E5U/14F5E/14F5U)	
25	4-050-851-01	KNOB, CONTROL (14E5E/14E5U/14F5E/14F5U)	
26	* A-1372-133-A	MOUNTED PCB, HA (14E5E/14E5U/14F5E/14F5U)	
27	* A-1372-134-A	MOUNTED PCB, HB (14E5E/14E5U/14F5E/14F5U)	
28	* A-1375-149-A	COMPLETE PCB, HC (14E5E/14E5U/14F5E/14F5U)	
29	* 4-053-255-01	GASKET (S), EMI	
30	* 4-053-254-01	GASKET (L), EMI	
31	4-050-924-01	BRACKET (LEFT), BEZEL (14E5E/14E5U/14F5E/14F5U)	
32	4-050-925-01	BRACKET (RIGHT), BEZEL (14E5E/14E5U/14F5E/14F5U)	
33	* 4-053-987-01	INSULATOR, YC PC BOARD	
34	X-4033-276-1	GUARD ASSY, HARNESS (L) (14E1E/14E1U/14F1E/14F1U)	
35	X-4033-277-1	GUARD ASSY, HARNESS (S) (14E1E/14E1U/14F1E/14F1U)	

## 6-2. CHASSIS (BVM-14E1E/14E1U/14E5E/14E5U/14F1E/14F1U/14F5E/14F5U)

● : 7-685-648-71 +BVTP 3x12  
 △ : 7-682-548-04 +BVTT 3x8



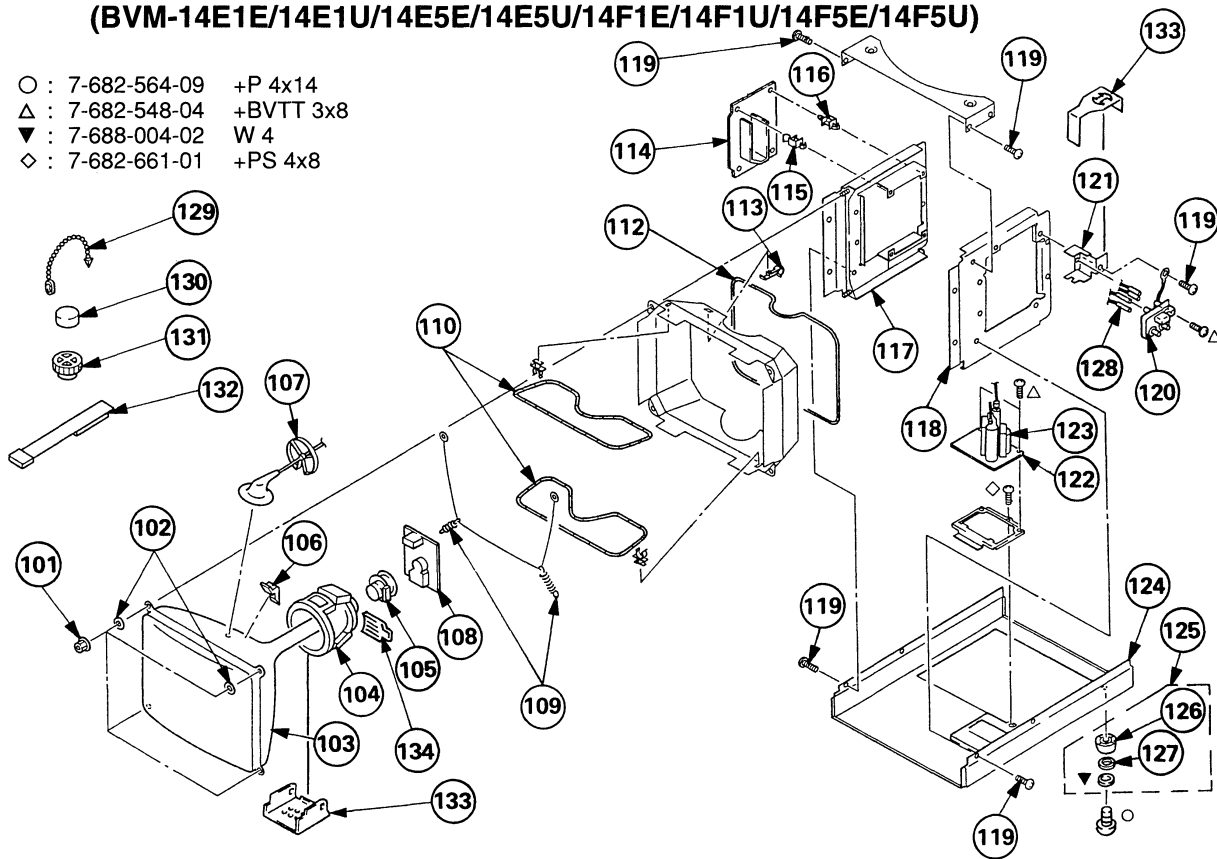
The components identified by shading and marked △ are critical for safety.  
 Replace only with part number specified.

Les composants identifiés par une trame et une marque △ sont critiques pour la sécurité.  
 Ne les remplacer que par une pièce portant le numéro spécifié.

REF NO.	PART NO.	DESCRIPTION	REMARK
51	* A-1390-530-A	MOUNTED PCB, TA (14E1E/14E1U/14F1E/14F1U)	
51	* A-1390-532-A	MOUNTED PCB, TA (14E5E/14E5U/14F5E/14F5U)	
52	* 4-050-842-01	BRACKET (L), T (14E5E/14E5U/14F5E/14F5U)	
52	* 4-050-965-01	BRACKET (L), T (14E1E/14E1U/14F1E/14F1U)	
53	* 4-050-808-01	SHIELD, T (14E5E/14E5U/14F5E/14F5U)	
53	* 4-050-957-01	SHIELD, T (14E1E/14E1U/14F1E/14F1U)	
54	* A-1390-531-A	MOUNTED PCB, TB (14E1E/14E1U/14F1E/14F1U)	
54	* A-1390-606-A	MOUNTED PCB, TB (14E5E/14E5U/14F5E/14F5U)	
55	* 4-050-843-01	BRACKET (R), T (14E5E/14E5U/14F5E/14F5U)	
55	* 4-050-964-01	BRACKET (R), T (14E1E/14E1U/14F1E/14F1U)	
56	* 4-050-847-01	PLATE (UPPER), NUT (14E5E/14E5U/14F5E/14F5U)	
56	* 4-050-959-01	PLATE (UPPER), NUT (14E1E/14E1U/14F1E/14F1U)	
57	* 4-050-844-01	BOARD, CARD SLOT (14E5E/14E5U/14F5E/14F5U)	
57	* 4-050-969-01	BOARD, CARD SLOT (14E1E/14E1U/14F1E/14F1U)	
58	* 4-050-848-01	PLATE (LOWER), NUT (14E5E/14E5U/14F5E/14F5U)	
58	* 4-050-960-01	PLATE (LOWER), NUT (14E1E/14E1U/14F1E/14F1U)	
59	* 4-050-816-01	BRACKET, HD (14E1E/14E1U/14F1E/14F1U)	
60	* A-1372-136-A	MOUNTED PCB, HD (14E1E/14E1U/14F1E/14F1U)	
61	4-381-962-11	SCREW +BVTT 4X8 (S)	
62	1-533-702-11	HOLDER, FUSE	
63	△ 1-532-746-11	FUSE, GLASS TUBE 4A/125V (14E1U/14E5U/14F1U/14F5U)	
63	△ 1-576-230-31	FUSE (H.B.C) T3.15A/250V (14E1E/14E5E/14F1E/14F5E)	
64	* A-1316-258-A	COMPLETE PCB, G	65, 66, 76
65	* A-1311-432-A	MOUNTED PCB, GA	
66	* A-1311-433-A	MOUNTED PCB, GB	
67	* X-4033-116-2	FRAME ASSY, POWER	
68	* A-1346-357-B	COMPLETE PCB, E	69, 70
69	* X-4033-108-1	HEAT SINK (DEFLECTION) ASSY	
70	* A-1341-958-B	MOUNTED PCB, D	
71	* A-1135-861-B	COMPLETE PCB, BK	72, 73
72	X-4033-103-1	HEAT SINK ASSY (BK)	
73	* X-4033-105-1	PANEL (BK) ASSY, CONNECTOR	
74	* A-1135-825-B	COMPLETE PCB, BC	75
75	* X-4033-106-1	PANEL (BC) ASSY, CONNECTOR	
76	* A-1311-467-A	MOUNTED PCB GC	
77	* 4-053-287-01	GASKET	
78	* 4-053-287-11	GASKET (14E5E/14E5U/14F5E/14F5U)	
78	* 4-053-287-21	GASKET (14E1E/14E1U/14F1E/14F1U)	

### 6-3. PICTURE TUBE (BVM-14E1E/14E1U/14E5E/14E5U/14F1E/14F1U/14F5E/14F5U)

- : 7-682-564-09 +P 4x14
- △ : 7-682-548-04 +BVTT 3x8
- ▼ : 7-688-004-02 W 4
- ◇ : 7-682-661-01 +PS 4x8



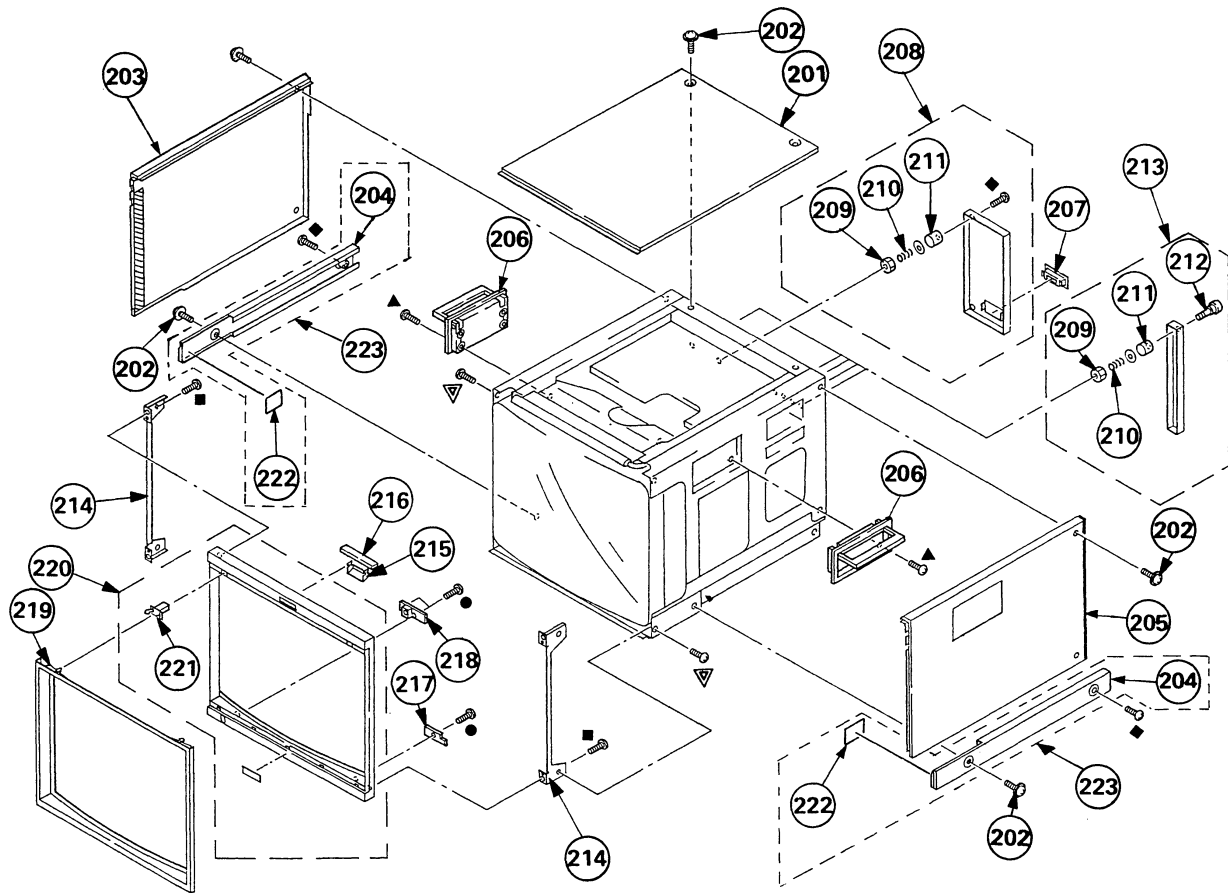
Les composants identifiés par une trame et une marque △ sont critiques pour la sécurité. Ne les remplacer que par une pièce portant le numéro spécifié.

The components identified by shading and marked △ are critical for safety. Replace only with part number specified.

REF NO.	PART NO.	DESCRIPTION	REMARK	REF NO.	PART NO.	DESCRIPTION	REMARK
101	4-306-034-01	NUT,(B) (M5), FLANGE		115	* 3-703-141-11	HOLDER, PCB	
102	4-348-567-01	WASHER, CRT POSITION		116	* 4-353-620-11	HINGE, PC BOARD	
103	△ 8-738-332-05	PICTURE TUBE 14MT1(BVM)		117	4-050-927-01	CHASSIS (L) (14E5E/14E5U/14F5E/14F5U)	
		(14F1E/14F5E)		118	4-050-926-01	CHASSIS (R) (14E5E/14E5U/14F5E/14F5U)	
103	△ 8-738-334-05	PICTURE TUBE 14MT3(BVM)			4-050-962-01	CHASSIS (R) (14E1E/14E1U/14F1E/14F1U)	
		(14F1U/14F5U)		119	7-685-881-01	SCREW +BVTT 4X8	
103	△ 8-738-337-05	PICTURE TUBE 14MP1 (14E1E/14F14E5E)		120	△ 1-223-417-12	RESISTOR ASSY (HIGH-VOLTAGE)	
103	△ 8-738-338-05	PICTURE TUBE 14MP3 (14E1U/14F14E5U)		121	* 4-050-921-01	BRACKET, FOCUS	
104	△ 8-451-473-11	DY Y14MPDT		122	* A-1190-238-A	MOUNTED PCB, PC	
105	△ 1-452-436-41	NECK ASSY, CRT (NA292)		123	△ X-4033-491-1	FBT ASSY, NX4201/J1F4	
106	4-050-492-01	SPACER, DY		124	* X-4033-129-2	CHASSIS ASSY, BOTTOM (14E5E/14E5U/14F5E/14F5U)	
107	* 4-047-349-01	HOLDER, HV CABLE		124	X-4033-143-2	CHASSIS ASSY, BOTTOM (14E1E/14E1U/14F1E/14F1U)	
108	* A-1331-457-A	MOUNTED PCB, C (14F1E/14F1U/14F5E/14F5U)		125	X-4033-117-1	FOOT ASSY	126, 127
108	* A-1331-520-A	MOUNTED PCB, C (14E1E/14E1U/14E5E/14E5U)		126	X-4836-202-9	FOOT	
109	4-303-774-03	SPRING		127	* 3-668-845-01	CUSHION, LEG	
110	△ 1-411-660-11	COIL, DEMAGNETIC		128	1-900-214-62	LEAD ASSY, FOCUS	
111	* 4-395-824-01	HOLDER, DEGAUSSING COIL		129	4-308-870-00	CLIP, LEAD WIRE	
112	△ 1-411-658-11	COIL, LANDING CORRECTION		130	1-452-032-11	MAGNET, DISK; 10MM Ø	
113	4-045-123-01	HOLDER, DEGAUSSING COIL		131	1-452-094-00	MAGNET, ROTA TABLE DISK; 15MM Ø	
114	* A-1195-098-B	COMPLETE PCB, PA (14F1E/14F1U/14F5E/14F5U)		132	X-4308-815-8	PERMALLOY ASSY, CONVERGENCE	
114	* A-1195-111-A	COMPLETE PCB, PA (14E1E/14E1U/14E5E/14E5U)		133	4-053-410-01	SHIELD, DY	
				134	X-2105-533-1	PLATE ASSY, CORRECTION, TLH	

## 6-4. COVER (BVM-20E1E/20E1U/20F1E/20F1U)

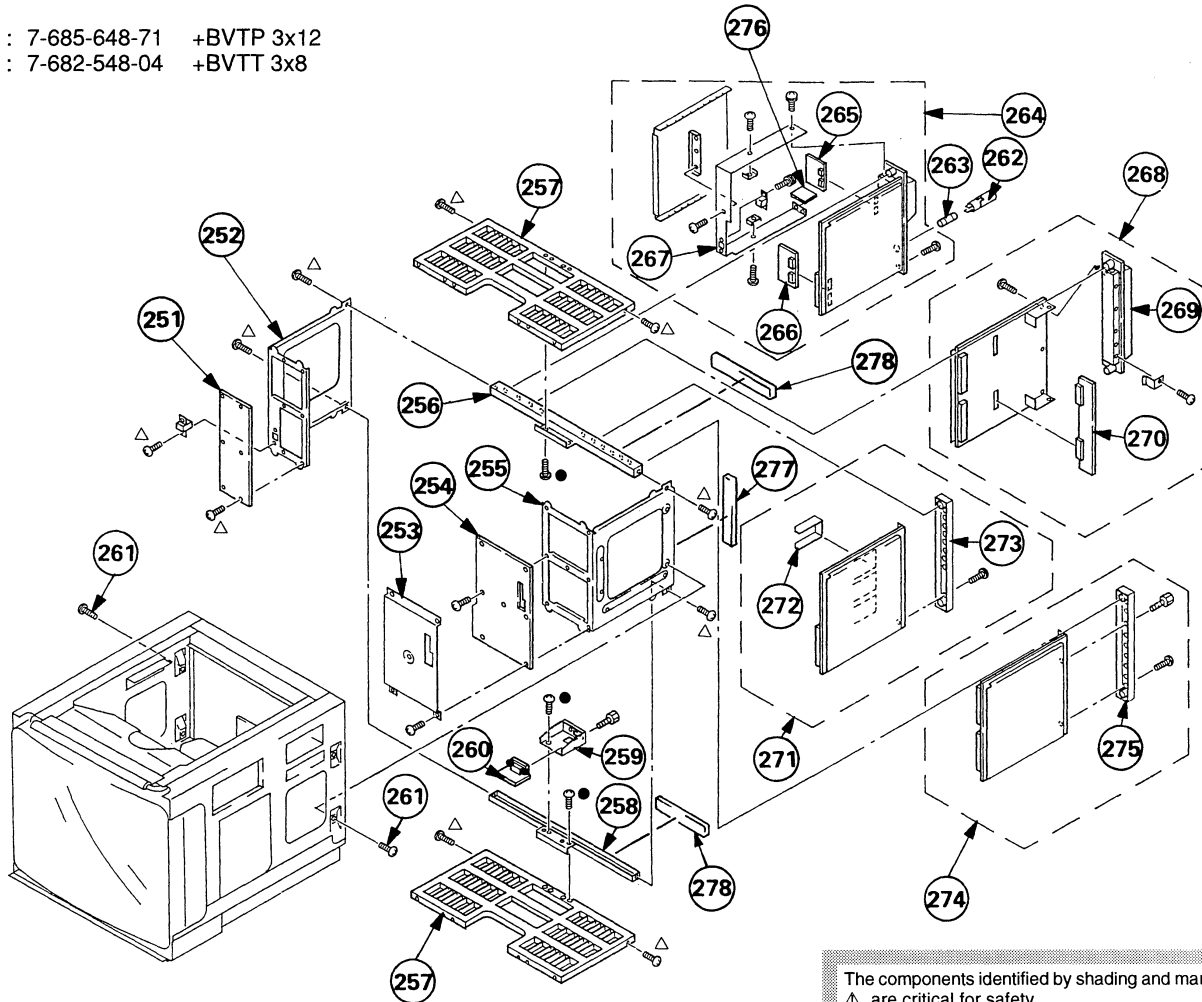
- : 7-685-648-71 +BVTP 3x12
- ▲ : 7-685-872-09 +BVTT 3x8
- : 7-685-661-14 +BVTP 4x12
- ◆ : 7-682-566-04 +B 4x20
- ▽ : 7-682-561-09 +B 4x8



REF NO.	PART NO.	DESCRIPTION	REMARK	REF NO.	PART NO.	DESCRIPTION	REMARK
201	X-4033-308-1	CABINET ASSY, TOP		213	* X-4033-104-1	PANEL ASSY, BLANK	209-212
202	4-847-802-11	SCREW (OS), CASE, CLAW		214	* 4-050-830-01	BRACKET, BEZEL	
203	X-4033-310-1	CABINET ASSY, LEFT		215	* 4-050-876-02	PLATE, LIGHT INTERCEPTION	
204	4-050-836-01	COVER BLIND		216	* A-1373-523-A	MOUNTED PCB, YA	
205	X-4033-309-1	CABINET ASSY, RIGHT		217	* A-1373-524-A	MOUNTED PCB, YB	
206	X-3642-018-3	HANDLE ASSY		218	* A-1373-525-A	MOUNTED PCB, YC	
207	4-050-821-02	ESCUTCHEON		219	X-4033-112-1	MASK (4:3) ASSY	
208	* X-4033-110-1	PANEL ASSY, REAR	209-211	220	X-4033-111-1	BEZEL ASSY	221
209	* 3-648-057-01	NUT (ISO-4), U		221	4-051-061-02	HOLDER	
210	* 4-403-012-01	SPRING, STOPPER		222	3-342-839-02	CUSHON	
211	* 4-050-795-01	SPACER, REAR PANEL		223	X-4033-324-1	COVER ASSY, BLIND	204, 222
212	* 4-050-804-01	SCREW, PANEL STOPPER					

## 6-5. CHASSIS (BVM-20E1E/20E1U/20F1E/20F1U)

- : 7-685-648-71 +BVTP 3x12
- △ : 7-682-548-04 +BVTT 3x8



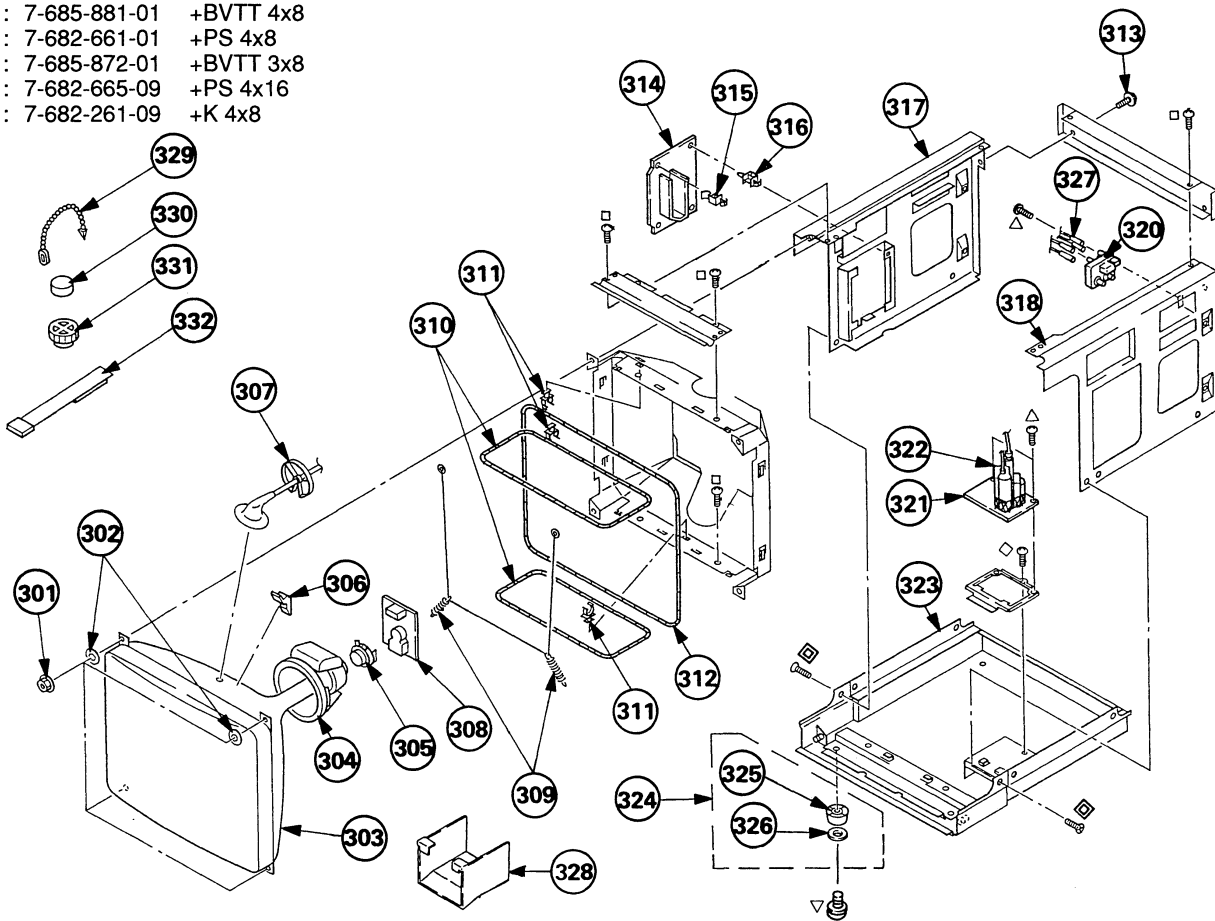
The components identified by shading and marked  $\Delta$  are critical for safety. Replace only with part number specified.

Les composants identifiés par une trame et une marque  $\Delta$  sont critiques pour la sécurité. Ne les remplacer que par une pièce portant le numéro spécifié.

REF NO.	PART NO.	DESCRIPTION	REMARK	REF NO.	PART NO.	DESCRIPTION	REMARK
251	* A-1390-532-A	MOUNTED PCB, TA		264	* A-1316-258-A	COMPLETE PCB, G	265, 266, 276
252	* 4-050-842-01	BRACKET (L), T		265	* A-1311-432-A	MOUNTED PCB, GA	
253	* 4-050-808-01	SHIELD, T		266	* A-1311-433-A	MOUNTED PCB, GB	
254	* A-1390-533-A	MOUNTED PCB, TB		267	* X-4033-116-2	FRAME ASSY, POWER	
255	* 4-050-843-01	BRACKET (R), T		268	* A-1346-356-B	COMPLETE PCB, E	269, 270
256	* 4-050-847-01	PLATE (UPPER), NUT		269	* X-4033-108-1	HEAT SINK (DEFLECTION) ASSY	
257	* 4-050-844-01	BOARD, CARD SLOT		270	* A-1341-958-B	MOUNTED PCB, D	
258	* 4-050-848-01	PLATE (LOWER), NUT		271	* A-1135-826-A	COMPLETE PCB, BK	
259	* 4-050-816-01	BRACKET, HD		272	X-4033-103-1	HEAT SINK ASSY (BK)	
260	* A-1372-136-A	MOUNTED PCB, HD		273	* X-4033-105-1	PANEL (BK) ASSY, CONNECTOR	
261	4-381-962-11	SCREW +BVTT4X8 (S)		274	* A-1135-825-B	COMPLETE PCB, BC	275
262	1-533-702-11	HOLDER, FUSE		275	* X-4033-106-1	PANEL (BC) ASSY, CONNECTOR	
263 $\Delta$	1-576-230-81	FUSE (H.B.C) T3.15A/250V (20E1E/20F1E)		276	* A-1311-467-A	MOUNTED PCB, GC	
263 $\Delta$	1-532-746-11	FUSE. GLASS TUBE 4A/125V (20E1U/20F1U)		277	4-053-287-01	GASKET	
				278	4-053-287-11	GASKET	

## 6-6. PICTURE TUBE (BVM-20E1E/20E1U/20F1E/20F1U)

- : 7-685-881-01 +BVTT 4x8
- ◇ : 7-682-661-01 +PS 4x8
- △ : 7-685-872-01 +BVTT 3x8
- ▽ : 7-682-665-09 +PS 4x16
- ◆ : 7-682-261-09 +K 4x8



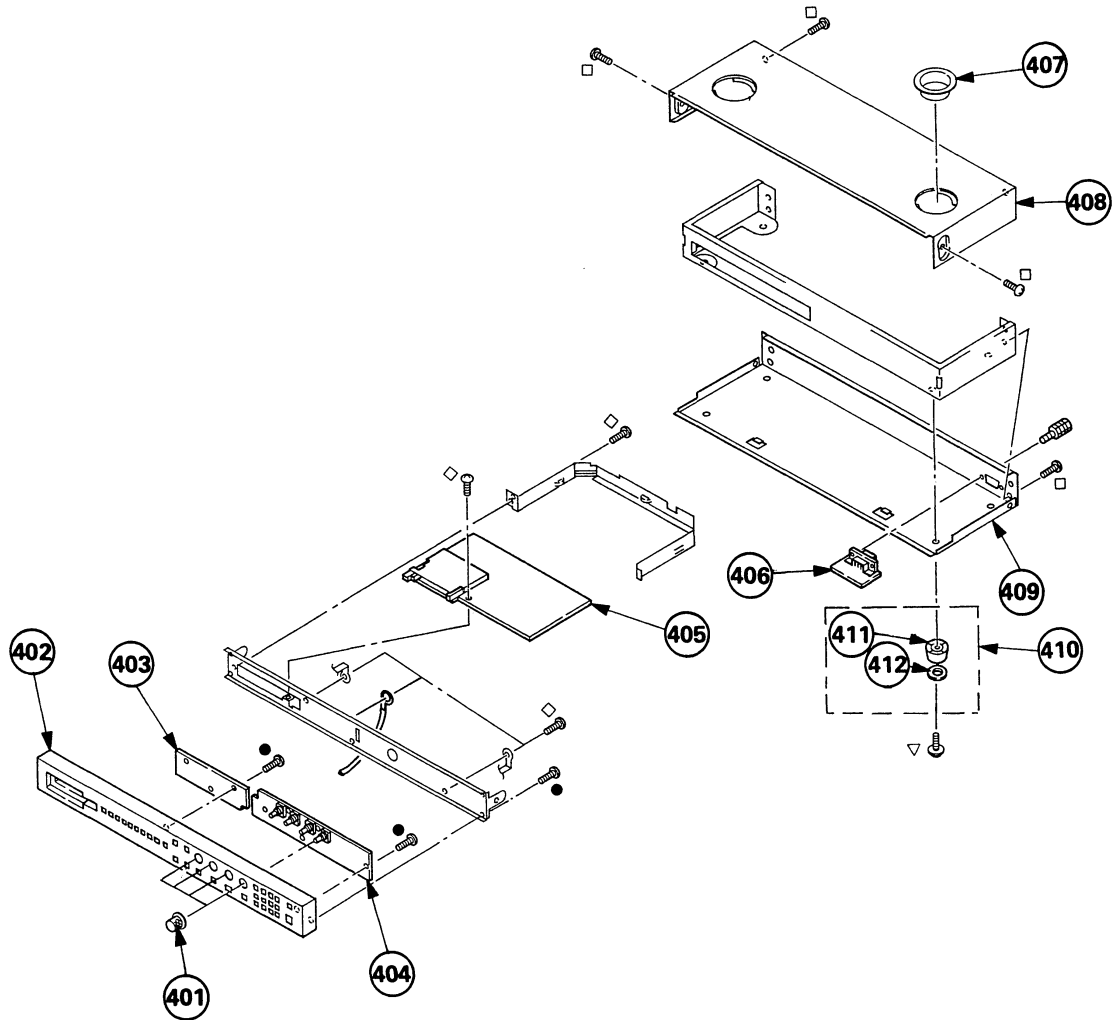
Les composants identifiés par une trame et une marque △ sont critiques pour la sécurité. Ne les remplacer que par une pièce portant le numéro spécifié.

The components identified by shading and marked △ are critical for safety. Replace only with part number specified.

REF NO.	PART NO.	DESCRIPTION	REMARK	REF NO.	PART NO.	DESCRIPTION	REMARK
301	4-306-034-01	NUT,(B) (M5), FLANGE		314	* A-1195-104-A	COMPLETE PCB, PA (20E1E/20E1U)	
302	4-348-567-01	WASHER, CRT POSITION		315	* 3-703-141-11	HOLDER, PCB	
303	△ 8-736-375-05	PICTURE TUBE (20MT3) (20F1U)		316	* 4-353-620-11	HINGE, PC BOARD	
303	△ 8-736-376-05	PICTURE TUBE (20MP1) (20E1E)		317	* X-4033-114-1	CHASSIS ASSY, LEFT	
303	△ 8-736-377-05	PICTURE TUBE (Y20MPDM) (20E1U)		318	* X-4033-115-1	CHASSIS ASSY, RIGHT	
303	△ 8-736-384-05	PICTURE TUBE (20MT1) (S) (20F1E: SOUTH)		320	△ 1-223-417-12	RESISTOR ASSY (HIGH-VOLTAGE)	
303	△ 8-736-374-05	PICTURE TUBE (20MT1) (20F1E: NORTH)		321	* A-1190-229-A	MOUNTED PCB, PC	
303	△ 8-736-384-05	PICTURE TUBE (20MT1) (S) (20E1U: SOUTH)		322	△ X-4033-492-1	FBT ASSY, NX-4201//JIE4	
304	△ 8-451-470-11	DY Y20MPDM		323	* X-4033-113-1	PLATE ASSY, BOTTOM	
305	△ 8-453-003-11	NA3012(M)		324	X-4033-117-1	FOOT ASSY	325, 326
306	4-040-897-01	SPACER, DY		325	X-4836-202-9	FOOT	
307	* 4-047-349-01	HOLDER, HV CABLE		326	* 3-668-845-01	CUSHION, LEG	
308	* A-1331-457-A	MOUNTED PCB, C (20F1E/20F1U)		327	1-900-214-33	LEAD ASSY, FOCUS	
308	* A-1331-520-A	MOUNTED PCB, C (20E1U)		328	* X-4033-336-3	SHILD ASSY, DY	
309	* 4-303-774-XX	SPRING		329	4-308-870-00	CLIP, LEAD WIRE	
310	△ 1-411-659-11	COIL, DEMAGNETIC		330	1-452-032-11	MAGNET, DISK; 10MM Ø	
311	* 4-395-824-02	HOLDER, DEGAUSSING COIL		331	1-452-094-00	MAGNET, ROTA TABLE DISK; 15MM Ø	
312	△ 1-411-657-11	COIL, LANDING CORRECTION		332	X-4309-608-7	PERMALLOY ASSY, CONVERGENCE	
313	4-847-802-11	SCREW (OS), CASE, CLAW					
314	* A-1195-097-A	COMPLETE PCB, PA (20F1E/20F1U)					

## 6-7. CONTROL (BKM-10R)

- : 7-685-648-71 +BVTP 3x12
- : 7-682-561-04 +B 4x8
- ▽ : 7-682-665-09 +PS 4x16
- ◇ : 7-682-947-01 +PSW 3x6



REF NO.	PART NO.	DESCRIPTION	REMARK	REF NO.	PART NO.	DESCRIPTION	REMARK
401	4-050-851-01	KNOB, CONTROL		407	4-050-852-01	HOLDER, FOOT	
402	X-4033-118-1	PANEL ASSY, CONTROL		408	4-050-858-01	COVER (TOP)	
403	* A-1372-134-A	MOUNTED PCB, HB		409	4-050-857-01	COVER (BOTTOM)	
404	* A-1372-133-A	MOUNTED PCB, HA		410	X-4033-117-1	FOOT ASSY	411, 412
405	* A-1375-149-A	COMPLETE PCB, HC		411	4-306-405-01	FOOT	
406	* A-1372-136-A	MOUNTED PCB, HD		412	* 3-668-845-01	CUSHION, LEG	





# SECTION 7 ELECTRICAL PARTS LIST

BC

The components identified by shading and marked  $\Delta$  are critical for safety. Replace only with the part number specified.

Les composants identifiés par une trame et une marque  $\Delta$  sont critiques pour la sécurité. Ne les remplacer que par une pièce portant le numéro spécifié.

- Items marked " \* " are not stocked since they are seldom required for routine service. Some delay should be anticipated when ordering these items.

- All variable and adjustable resistors have characteristic curve B, unless otherwise noted.

**RESISTORS**

- All resistors are in ohms
- F : nonflammable

**CAPACITORS**

- PF :  $\mu\text{F}$

When indicating parts by reference number, please include the board name.

- The components identified by  $\boxtimes$  in this manual have been carefully factory-selected for each set in order to satisfy regulations regarding X-ray radiation. Should replacement be required, replace only with the value originally used.
- There are some cases the reference number on one board overlaps on the other board. Therefore, when ordering parts by the reference number, please include the board name.

REF NO.	PART NO.	DESCRIPTION	REMARK	REF NO.	PART NO.	DESCRIPTION	REMARK
	*A-1135-825-B	COMPLETE PCB, BC *****		C44	1-163-038-91	CERAMIC CHIP	0.1 $\mu$ F 25V
		BATTERY, LITHIUM (BAT 1), (CR2025)		C45	1-163-038-91	CERAMIC CHIP	0.1 $\mu$ F 25V
	*X-4033-106-1	PANEL (BC) ASSY, CONNECTOR		C46	1-163-235-11	CERAMIC CHIP	22pF 5% 50V
	1-550-104-11	HOLDER, BATTERY		C47	1-163-235-11	CERAMIC CHIP	22pF 5% 50V
	*4-050-795-01	SPACER, REAR PANEL		C101	1-163-031-11	CERAMIC CHIP	0.01 $\mu$ F 50V
	*4-050-804-01	SCREW, PANEL STOPPER		C102	1-163-031-11	CERAMIC CHIP	0.01 $\mu$ F 50V
	*4-050-814-01	SHIELD, PCB		C104	1-164-222-11	CERAMIC CHIP	22pF 25V
				C105	1-163-235-11	CERAMIC CHIP	22pF 5% 50V
	*4-403-012-01	SPRING, STOPPER		C106	1-163-235-11	CERAMIC CHIP	22pF 5% 50V
	7-432-114-11	SCREW LOCK		C107	1-163-235-11	CERAMIC CHIP	22pF 5% 50V
	7-623-422-07	LW 3, TYPE B		C108	1-163-235-11	CERAMIC CHIP	22pF 5% 50V
	7-685-871-01	SCREW +BVTT 3X6 (S)		C109	1-163-038-91	CERAMIC CHIP	0.1 $\mu$ F 25V
	7-682-548-09	SCREW +BVTT 3X8 (S)		C110	1-163-031-11	CERAMIC CHIP	0.01 $\mu$ F 50V
		< CAPACITOR >		C111	1-164-505-11	CERAMIC CHIP	2.2 $\mu$ F 16V
				C112	1-164-505-11	CERAMIC CHIP	2.2 $\mu$ F 16V
C1	1-163-235-11	CERAMIC CHIP	22pF 5% 50V	C113	1-163-031-11	CERAMIC CHIP	0.01 $\mu$ F 50V
C2	1-163-235-11	CERAMIC CHIP	22pF 5% 50V	C114	1-163-031-11	CERAMIC CHIP	0.01 $\mu$ F 50V
C3	1-163-235-11	CERAMIC CHIP	22pF 5% 50V	C115	1-163-235-11	CERAMIC CHIP	22pF 5% 50V
C4	1-163-235-11	CERAMIC CHIP	22pF 5% 50V	C116	1-163-235-11	CERAMIC CHIP	22pF 5% 16V
C5	1-126-396-11	ELECT CHIP	47 $\mu$ F 20% 16V	C117	1-163-031-11	CERAMIC CHIP	0.01 $\mu$ F 16V
C7	1-163-031-11	CERAMIC CHIP	0.01 $\mu$ F 50V	C118	1-163-029-11	CERAMIC CHIP	0.0047 $\mu$ F 50V
C8	1-163-031-11	CERAMIC CHIP	0.01 $\mu$ F 50V	C151	1-126-396-11	ELECT CHIP	47 $\mu$ F 20% 16V
C9	1-163-031-11	CERAMIC CHIP	0.01 $\mu$ F 50V	C154	1-164-004-11	CERAMIC CHIP	0.1 $\mu$ F 10% 25V
C10	1-163-275-11	CERAMIC CHIP	0.001 $\mu$ F 5% 50V	C155	1-164-182-11	CERAMIC CHIP	0.0033 $\mu$ F 10% 50V
C11	1-163-275-11	CERAMIC CHIP	0.001 $\mu$ F 5% 50V	C156	1-164-344-11	CERAMIC CHIP	0.068 $\mu$ F 10% 25V
C12	1-163-031-11	CERAMIC CHIP	0.01 $\mu$ F 50V	C161	1-126-404-11	ELECT CHIP	4.7 $\mu$ F 20% 50V
C13	1-163-031-11	CERAMIC CHIP	0.01 $\mu$ F 50V	C162	1-163-251-11	CERAMIC CHIP	100pF 5% 50V
C14	1-163-031-11	CERAMIC CHIP	0.01 $\mu$ F 50V	C163	1-162-638-11	CERAMIC CHIP	1 $\mu$ F 16
C15	1-163-031-11	CERAMIC CHIP	0.01 $\mu$ F 50V	C164	1-163-141-00	CERAMIC CHIP	0.001 $\mu$ F 5% 50V
C16	1-163-031-11	CERAMIC CHIP	0.01 $\mu$ F 50V	C165	1-162-637-11	CERAMIC CHIP	0.47 $\mu$ F 16V
C17	1-163-031-11	CERAMIC CHIP	0.01 $\mu$ F 50V	C166	1-164-695-11	CERAMIC CHIP	0.0022 $\mu$ F 5% 50V
C18	1-163-031-11	CERAMIC CHIP	0.01 $\mu$ F 50V	C167	1-164-506-11	CERAMIC CHIP	4.7 $\mu$ F 16V
C19	1-163-031-11	CERAMIC CHIP	0.01 $\mu$ F 50V	C168	1-164-506-11	CERAMIC CHIP	4.7 $\mu$ F 16V
C20	1-163-031-11	CERAMIC CHIP	0.01 $\mu$ F 50V	C169	1-163-141-00	CERAMIC CHIP	0.001 $\mu$ F 5% 50V
C31	1-163-038-91	CERAMIC CHIP	0.1 $\mu$ F 25V	C170	1-162-638-11	CERAMIC CHIP	1 $\mu$ F 16V
C32	1-163-038-91	CERAMIC CHIP	0.1 $\mu$ F 25V	C171	1-162-638-11	CERAMIC CHIP	1 $\mu$ F 16V
C33	1-163-038-91	CERAMIC CHIP	0.1 $\mu$ F 25V	C181	1-126-401-11	ELECT CHIP	1 $\mu$ F 20% 50V
C34	1-163-038-91	CERAMIC CHIP	0.1 $\mu$ F 25V	C183	1-126-401-11	ELECT CHIP	1 $\mu$ F 20% 50V
C35	1-163-038-91	CERAMIC CHIP	0.1 $\mu$ F 25V	C184	1-164-489-11	CERAMIC CHIP	0.22 $\mu$ F 10% 16V
C36	1-163-038-91	CERAMIC CHIP	0.1 $\mu$ F 25V	C185	1-163-251-11	CERAMIC CHIP	100pF 5% 50V
C37	1-163-038-91	CERAMIC CHIP	0.1 $\mu$ F 25V	C201	1-126-392-11	ELECT CHIP	100 $\mu$ F 20% 6.3V
C39	1-163-038-91	CERAMIC CHIP	0.1 $\mu$ F 25V	C202	1-126-392-11	ELECT CHIP	100 $\mu$ F 20% 6.3V
C41	1-163-038-91	CERAMIC CHIP	0.1 $\mu$ F 25V	C203	1-126-392-11	ELECT CHIP	100 $\mu$ F 20% 6.3V
C42	1-163-038-91	CERAMIC CHIP	0.1 $\mu$ F 25V	C204	1-126-392-11	ELECT CHIP	100 $\mu$ F 20% 6.3V
C43	1-163-038-91	CERAMIC CHIP	0.1 $\mu$ F 25V	C205	1-126-392-11	ELECT CHIP	100 $\mu$ F 20% 6.3V

REF NO.	PART NO.	DESCRIPTION	REMARK	REF NO.	PART NO.	DESCRIPTION	REMARK
C206	1-126-392-11	ELECT CHIP	100µ F 20% 6.3V	C322	1-163-031-11	CERAMIC CHIP	0.01µ F 50V
C207	1-126-392-11	ELECT CHIP	100µ F 20% 6.3V	C323	1-163-031-11	CERAMIC CHIP	0.01µ F 50V
C208	1-126-392-11	ELECT CHIP	100µ F 20% 6.3V	C324	1-163-031-11	CERAMIC CHIP	0.01µ F 50V
C209	1-126-392-11	ELECT CHIP	100µ F 20% 6.3V	C325	1-163-031-11	CERAMIC CHIP	0.01µ F 50V
C210	1-126-392-11	ELECT CHIP	100µ F 20% 6.3V	C326	1-163-031-11	CERAMIC CHIP	0.01µ F 50V
C211	1-126-392-11	ELECT CHIP	100µ F 20% 6.3V	C327	1-163-031-11	CERAMIC CHIP	0.01µ F 50V
C212	1-126-392-11	ELECT CHIP	100µ F 20% 6.3V	C328	1-163-031-11	CERAMIC CHIP	0.01µ F 50V
C213	1-126-392-11	ELECT CHIP	100µ F 20% 6.3V	C329	1-163-031-11	CERAMIC CHIP	0.01µ F 50V
C214	1-126-392-11	ELECT CHIP	100µ F 20% 6.3V	C330	1-163-031-11	CERAMIC CHIP	0.01µ F 50V
C215	1-126-392-11	ELECT CHIP	100µ F 20% 6.3V	C331	1-163-031-11	CERAMIC CHIP	0.01µ F 50V
C216	1-126-392-11	ELECT CHIP	100µ F 20% 6.3V	C332	1-163-031-11	CERAMIC CHIP	0.01µ F 50V
C217	1-126-392-11	ELECT CHIP	100µ F 20% 6.3V	C333	1-163-031-11	CERAMIC CHIP	0.01µ F 50V
C218	1-126-392-11	ELECT CHIP	100µ F 20% 6.3V	C334	1-163-031-11	CERAMIC CHIP	0.01µ F 50V
C219	1-126-392-11	ELECT CHIP	100µ F 20% 6.3V	C335	1-163-031-11	CERAMIC CHIP	0.01µ F 50V
C220	1-126-392-11	ELECT CHIP	100µ F 20% 6.3V	C336	1-163-031-11	CERAMIC CHIP	0.01µ F 50V
C231	1-126-392-11	ELECT CHIP	100µ F 20% 6.3V	C337	1-163-031-11	CERAMIC CHIP	0.01µ F 50V
C232	1-126-392-11	ELECT CHIP	100µ F 20% 6.3V	C338	1-163-031-11	CERAMIC CHIP	0.01µ F 50V
C233	1-126-392-11	ELECT CHIP	100µ F 20% 6.3V	C339	1-163-031-11	CERAMIC CHIP	0.01µ F 50V
C234	1-126-392-11	ELECT CHIP	100µ F 20% 6.3V	C340	1-163-031-11	CERAMIC CHIP	0.01µ F 50V
C235	1-126-392-11	ELECT CHIP	100µ F 20% 6.3V	C341	1-135-216-11	TANTAL. CHIP	10µ F 20% 10V
C236	1-126-392-11	ELECT CHIP	100µ F 20% 6.3V	C342	1-135-216-11	TANTAL. CHIP	10µ F 20% 10V
C237	1-126-392-11	ELECT CHIP	100µ F 20% 6.3V	C343	1-135-216-11	TANTAL. CHIP	10µ F 20% 10V
C241	1-126-392-11	ELECT CHIP	100µ F 20% 6.3V	C344	1-135-216-11	TANTAL. CHIP	10µ F 20% 10V
C242	1-126-392-11	ELECT CHIP	100µ F 20% 6.3V	C351	1-163-031-11	CERAMIC CHIP	0.01µ F 50V
C243	1-126-392-11	ELECT CHIP	100µ F 20% 6.3V	C352	1-163-031-11	CERAMIC CHIP	0.01µ F 50V
C244	1-126-392-11	ELECT CHIP	100µ F 20% 6.3V	C357	1-163-031-11	CERAMIC CHIP	0.01µ F 50V
C245	1-126-392-11	ELECT CHIP	100µ F 20% 6.3V	C358	1-163-031-11	CERAMIC CHIP	0.01µ F 50V
C246	1-126-392-11	ELECT CHIP	100µ F 20% 6.3V	C359	1-163-031-11	CERAMIC CHIP	0.01µ F 50V
C247	1-126-397-11	ELECT CHIP	33µ F 20% 25V	C360	1-163-031-11	CERAMIC CHIP	0.01µ F 50V
C251	1-126-397-11	ELECT CHIP	33µ F 20% 25V	C362	1-163-031-11	CERAMIC CHIP	0.01µ F 50V
C252	1-126-396-11	ELECT CHIP	47µ F 20% 16V	C363	1-163-031-11	CERAMIC CHIP	0.01µ F 50V
C271	1-126-396-11	ELECT CHIP	47µ F 20% 16V	C364	1-163-031-11	CERAMIC CHIP	0.01µ F 50V
C281	1-126-392-11	ELECT CHIP	100µ F 20% 6.3V	C365	1-163-031-11	CERAMIC CHIP	0.01µ F 50V
C291	1-126-396-11	ELECT CHIP	47µ F 20% 16V	C366	1-163-031-11	CERAMIC CHIP	0.01µ F 50V
C301	1-163-031-11	CERAMIC CHIP	0.01µ F 50V	C367	1-163-031-11	CERAMIC CHIP	0.01µ F 50V
C302	1-163-031-11	CERAMIC CHIP	0.01µ F 50V	C368	1-163-031-11	CERAMIC CHIP	0.01µ F 50V
C303	1-163-031-11	CERAMIC CHIP	0.01µ F 50V	C369	1-163-031-11	CERAMIC CHIP	0.01µ F 50V
C304	1-163-031-11	CERAMIC CHIP	0.01µ F 50V	C370	1-163-031-11	CERAMIC CHIP	0.01µ F 50V
C305	1-163-031-11	CERAMIC CHIP	0.01µ F 50V	C371	1-163-031-11	CERAMIC CHIP	0.01µ F 50V
C306	1-163-031-11	CERAMIC CHIP	0.01µ F 50V	C372	1-163-031-11	CERAMIC CHIP	0.01µ F 50V
C307	1-163-031-11	CERAMIC CHIP	0.01µ F 50V	C373	1-163-031-11	CERAMIC CHIP	0.01µ F 50V
C308	1-163-031-11	CERAMIC CHIP	0.01µ F 50V	C374	1-163-031-11	CERAMIC CHIP	0.01µ F 50V
C309	1-163-031-11	CERAMIC CHIP	0.01µ F 50V	C375	1-163-031-11	CERAMIC CHIP	0.01µ F 50V
C310	1-163-031-11	CERAMIC CHIP	0.01µ F 50V	C376	1-163-031-11	CERAMIC CHIP	0.01µ F 50V
C311	1-163-031-11	CERAMIC CHIP	0.01µ F 50V	C377	1-164-505-11	CERAMIC CHIP	2.2µ F 16V
C312	1-163-031-11	CERAMIC CHIP	0.01µ F 50V	C391	1-163-031-11	CERAMIC CHIP	0.01µ F 50V
C313	1-163-031-11	CERAMIC CHIP	0.01µ F 50V	C392	1-163-031-11	CERAMIC CHIP	0.01µ F 50V
C314	1-163-031-11	CERAMIC CHIP	0.01µ F 50V	C401	1-163-251-11	CERAMIC	100pF 5% 50V
C315	1-163-031-11	CERAMIC CHIP	0.01µ F 50V	C402	1-163-251-11	CERAMIC	100pF 5% 50V
C316	1-163-031-11	CERAMIC CHIP	0.01µ F 50V			< CONNECTOR >	
C317	1-163-031-11	CERAMIC CHIP	0.01µ F 50V	CN1	1-774-523-11	PIN, CONNECTOR (PC BOARD) 64P	
C318	1-163-031-11	CERAMIC CHIP	0.01µ F 50V	CN2	1-774-523-11	PIN, CONNECTOR (PC BOARD) 64P	
C319	1-163-031-11	CERAMIC CHIP	0.01µ F 50V	CN3	1-565-269-11	SOCKET, CONNECTOR (D-DUB,L) 9P	(REMOTE1 IN)
C320	1-163-031-11	CERAMIC CHIP	0.01µ F 50V				
C321	1-163-031-11	CERAMIC CHIP	0.01µ F 50V				

REF NO.	PART NO.	DESCRIPTION	REMARK	REF NO.	PART NO.	DESCRIPTION	REMARK
CN4	1-565-269-11	SOCKET, CONNECTOR (D-DUB,L) 9P (REMOTE1 OUT)		IC10	8-759-926-11	IC SN74HC138ANS	
CN5	1-565-269-11	SOCKET, CONNECTOR (D-DUB,L) 9P (REMOTE2)		IC11	8-759-981-48	IC TL082M	
CN6	1-565-269-11	SOCKET, CONNECTOR (D-DUB,L) 9P (ISR)		IC12	8-759-232-44	IC TC74HC125AF	
		< DIODE >		IC13	8-759-926-11	IC SN74HC138ANS	
D1	8-719-158-15	DIODE RD5.6S-B		IC14	8-759-061-67	IC MC34051M	
D2	8-719-158-15	DIODE RD5.6S-B		IC15	8-759-925-74	IC SN74HC04ANS	
D3	8-719-158-15	DIODE RD5.6S-B		IC16	8-759-239-55	IC TC74HC123AF	
D4	8-719-158-15	DIODE RD5.6S-B		IC17	8-759-925-73	IC SN74HC03NS	
D5	8-719-158-15	DIODE RD5.6S-B		IC19	8-759-236-19	IC TC74HC151AF(EL)	
D12	8-719-109-92	DIODE RD6.2ES-B1		IC20	8-759-236-19	IC TC74HC151AF(EL)	
D13	8-719-404-46	DIODE MA110		IC21	8-759-236-19	IC TC74HC151AF(EL)	
D29	8-719-158-19	DIODE RD6.2SB		IC22	8-759-346-05	IC μ PD71051GU-10-E2	
D30	8-719-158-19	DIODE RD6.2SB		IC23	8-759-346-05	IC μ PD71051GU-10-E2	
D31	8-719-158-19	DIODE RD6.2SB		IC24	8-759-346-05	IC μ PD71051GU-10-E2	
D32	8-719-158-19	DIODE RD6.2SB		IC25	8-759-289-45	IC LTC485CS8	
D33	8-719-158-19	DIODE RD6.2SB		IC26	8-759-289-45	IC LTC485CS8	
D34	8-719-158-19	DIODE RD6.2SB		IC27	8-759-252-59	IC MAX202CSE	
D35	8-719-158-19	DIODE RD6.2SB		IC28	8-759-252-59	IC MAX202CSE	
D36	8-719-158-19	DIODE RD6.2SB		IC30	8-759-926-98	IC SN74HC4040ANS	
D37	8-719-158-19	DIODE RD6.2SB		IC31	8-759-925-74	IC SN74HC04ANS	
D38	8-719-158-19	DIODE RD6.2SB		IC32	8-759-925-75	IC SN74HC05ANS	
D39	8-719-158-19	DIODE RD6.2SB		IC33	8-759-925-75	IC SN74HC05ANS	
D40	8-719-158-19	DIODE RD6.2SB		IC34	8-759-007-56	IC MC74HC30F	
D41	8-719-158-19	DIODE RD6.2SB		IC35	8-759-296-77	IC MC74HC541AFEL	
D103	8-719-404-46	DIODE MA110		IC36	8-759-252-59	IC MAX202CSE	
D104	8-719-404-46	DIODE MA110		IC37	8-759-182-91	IC PQ12TZ5U	
D105	8-719-404-46	DIODE MA110		IC51	8-759-700-65	IC NJM79L05A	
D106	8-719-404-46	DIODE MA110		IC52	8-759-144-82	IC μ PC2405HF	
D107	8-719-404-46	DIODE MA110		IC101	8-759-514-57	IC BA7046F	
D108	8-719-404-46	DIODE MA110		IC102	8-752-064-20	IC CXA1727Q	
D109	8-719-404-46	DIODE MA110		IC103	8-752-353-22	IC CXD2122Q	
D111	8-719-404-46	DIODE MA110		IC104	8-759-926-98	IC SN74HC4040ANS	
D112	8-719-404-46	DIODE MA110		IC105	8-752-357-15	IC CXD2343S	
D113	8-719-404-46	DIODE MA110		IC106	8-759-037-80	IC MC74HC163AF-T1	
		< FILTER >		IC109	8-752-334-64	IC CXD1171M	
FL1	1-236-741-21	FILTER, EMI		IC110	8-759-232-80	IC TC74HC166AF	
FL2	1-236-741-21	FILTER, EMI		IC111	8-759-011-65	IC MC74HC4053F	
FL3	1-236-741-21	FILTER, EMI		IC113	8-759-032-23	IC MC74HC74AF	
FL5	1-236-741-21	FILTER, EMI		IC114	8-759-295-09	IC TLC2932IPW	
FL6	1-236-071-11	ENCAPSULATED COMPONENT		IC115	8-759-925-78	IC SN74HC10ANS	
		< IC >		IC116	8-759-011-65	IC MC74HC4053F	
IC1	8-759-333-47	IC HD6475368CP-10		IC117	8-759-032-01	IC MC74HC00AF	
IC2	8-759-346-07	IC MM1026BFB		IC118	8-759-100-93	IC μ PC393G2	
IC3	8-759-395-43	IC CAT28F020P		IC119	8-759-011-65	IC MC74HC4053F	
IC4	8-752-337-47	IC CXK58257AP-10LL		IC120	8-752-321-16	IC CXD1030M	
IC5	8-759-938-68	IC CXD1095Q		IC121	8-759-925-74	IC SN74HC04ANS	
IC6	8-759-938-68	IC CXD1095Q		IC122	8-759-032-11	IC MC74HC04AF	
IC7	8-759-054-57	IC μ PD6453GT-101		IC123	8-759-032-23	IC MC74HC74AF	
IC8	8-759-925-75	IC SN74HC05ANS		IC124	8-759-328-12	IC Z8622812PSC	
IC9	8-759-082-59	IC TC732FU		IC125	8-759-925-75	IC SN74HC05ANS	
				IC126	8-759-944-79	IC CXD1132Q	
						< IC SOCKET >	
				ICS1	1-540-222-11	SOCKET, IC (PCC PACKAGE) 84P	



Les composants identifiés par une trame et une marque Δ sont critiques pour la sécurité.  
Ne les remplacer que par une pièce portant le numéro spécifié.

The components identified by shading and marked Δ are critical for safety.  
Replace only with the part number specified.

REF NO.	PART NO.	DESCRIPTION	REMARK	REF NO.	PART NO.	DESCRIPTION	REMARK
ICS3	*1-526-660-21	SOCKET, IC (DP) 32P		Q9	8-729-921-12	TRANSISTOR 2SD1834	
ICS4	*1-526-659-00	SOCKET, IC (DP) 28P		Q101	8-729-901-06	TRANSISTOR DTA144EK	
ICS107	*1-526-659-00	SOCKET, IC (DP) 28P		Q102	8-729-901-06	TRANSISTOR DTA144EK	
ICS108	*1-526-659-00	SOCKET, IC (DP) 28P		Q103	8-729-901-06	TRANSISTOR DTA144EK	
		< CHIP CONDUCTOR >		Q104	8-729-901-06	TRANSISTOR DTA144EK	
JR3	1-216-295-91	CONDUCTOR, CHIP (2012)		Q106	8-729-216-22	TRANSISTOR 2SA1162-G	
JR5	1-216-295-91	CONDUCTOR, CHIP (2012)		Q107	8-729-120-28	TRANSISTOR 2SC1623-L5L6	
JR6	1-216-295-91	CONDUCTOR, CHIP (2012)		Q108	8-729-120-28	TRANSISTOR 2SC1623-L5L6	
JR9	1-216-295-91	CONDUCTOR, CHIP (2012)		Q109	8-729-216-22	TRANSISTOR 2SA1162-G	
JR10	1-216-295-91	CONDUCTOR, CHIP (2012)		Q110	8-729-901-06	TRANSISTOR DTA144EK	
JR12	1-216-295-91	CONDUCTOR, CHIP (2012)		Q111	8-729-120-28	TRANSISTOR 2SC1623-L5L6	
JR14	1-216-296-91	CONDUCTOR, CHIP (3216)		Q112	8-729-120-28	TRANSISTOR 2SC1623-L5L6	
JR101	1-216-295-91	CONDUCTOR, CHIP (2012)		Q113	8-729-120-28	TRANSISTOR 2SC1623-L5L6	
JR102	1-216-295-91	CONDUCTOR, CHIP (2012)		Q114	8-729-901-06	TRANSISTOR DTA144EK	
JR103	1-216-295-91	CONDUCTOR, CHIP (2012)		Q115	8-729-120-28	TRANSISTOR 2SC1623-L5L6	
JR104	1-216-295-91	CONDUCTOR, CHIP (2012)		Q116	8-729-901-01	TRANSISTOR DTC144EK	
JR105	1-216-295-91	CONDUCTOR, CHIP (2012)		Q151	8-729-120-28	TRANSISTOR 2SC1623-L5L6	
JR109	1-216-295-91	CONDUCTOR, CHIP (2012)		Q152	8-729-120-28	TRANSISTOR 2SC1623-L5L6	
JR110	1-216-295-91	CONDUCTOR, CHIP (2012)		Q153	8-729-120-28	TRANSISTOR 2SC1623-L5L6	
JR112	1-216-295-91	CONDUCTOR, CHIP (2012)		Q154	8-729-120-28	TRANSISTOR 2SC1623-L5L6	
JR114	1-216-296-91	CONDUCTOR, CHIP (3216)		Q155	8-729-216-22	TRANSISTOR 2SA1162-G	
JR115	1-216-296-91	CONDUCTOR, CHIP (3216)				< RESISTOR >	
JR116	1-216-296-91	CONDUCTOR, CHIP (3216)		R1	1-216-073-00	METAL GLAZE 10K	5% 1/10W
JR117	1-216-296-91	CONDUCTOR, CHIP (3216)		R2	1-216-073-00	METAL GLAZE 10K	5% 1/10W
JR118	1-216-296-91	CONDUCTOR, CHIP (3216)		R3	1-216-073-00	METAL GLAZE 10K	5% 1/10W
JR119	1-216-296-91	CONDUCTOR, CHIP (3216)		R4	1-216-073-00	METAL GLAZE 10K	5% 1/10W
JR120	1-216-295-91	CONDUCTOR, CHIP (2012)		R5	1-216-073-00	METAL GLAZE 10K	5% 1/10W
JR121	1-216-295-91	CONDUCTOR, CHIP (2012)		R6	1-216-073-00	METAL GLAZE 10K	5% 1/10W
JR122	1-216-295-91	CONDUCTOR, CHIP (2012)		R7	1-216-097-91	METAL GLAZE 100K	5% 1/10W
JR123	1-216-295-91	CONDUCTOR, CHIP (2012)		R10	1-216-121-91	METAL GLAZE 1M	5% 1/10W
JR124	1-216-295-91	CONDUCTOR, CHIP (2012)		R11	1-216-073-00	METAL GLAZE 10K	5% 1/10W
JR125	1-216-295-91	CONDUCTOR, CHIP (2012)		R12	1-216-049-91	METAL GLAZE 1K	5% 1/10W
		< COIL >		R13	1-216-049-91	METAL GLAZE 1K	5% 1/10W
L1	1-410-202-51	INDUCTOR CHIP 6.8μ H		R14	1-216-049-91	METAL GLAZE 1K	5% 1/10W
L201	1-412-537-31	INDUCTOR 100μ H		R15	1-216-049-91	METAL GLAZE 1K	5% 1/10W
		< FILTER >		R16	1-216-073-00	METAL GLAZE 10K	5% 1/10W
LPF101	1-239-289-11	FILTER, LOW PASS		R17	1-216-073-00	METAL GLAZE 10K	5% 1/10W
		< IC LINK >		R18	1-216-057-00	METAL GLAZE 2.2K	5% 1/10W
PS1 Δ 1-532-675-21	LINK, IC 1.5A/150V			R19	1-216-069-00	METAL GLAZE 6.8K	5% 1/10W
PS2 Δ 1-532-675-21	LINK, IC 1.5A/150V			R20	1-216-065-00	METAL GLAZE 4.7K	5% 1/10W
		< TRANSISTOR >		R21	1-216-077-00	METAL GLAZE 15K	5% 1/10W
Q1	8-729-901-01	TRANSISTOR DTC144EK		R22	1-216-073-00	METAL GLAZE 10K	5% 1/10W
Q2	8-729-901-06	TRANSISTOR DTA144EK		R23	1-216-651-11	METAL CHIP 1K	0.50% 1/10W
Q3	8-729-901-06	TRANSISTOR DTA144EK		R24	1-216-651-11	METAL CHIP 1K	0.50% 1/10W
Q4	8-729-901-01	TRANSISTOR DTC144EK		R25	1-216-651-11	METAL CHIP 1K	0.50% 1/10W
Q5	8-729-901-01	TRANSISTOR DTC144EK		R26	1-216-651-11	METAL CHIP 1K	0.50% 1/10W
Q6	8-729-122-13	TRANSISTOR 2SA11221-K		R27	1-216-049-91	METAL GLAZE 1K	5% 1/10W
Q7	8-729-122-13	TRANSISTOR 2SA11221-K		R28	1-216-049-91	METAL GLAZE 1K	5% 1/10W
Q8	8-729-901-01	TRANSISTOR DTC144EK		R29	1-216-295-91	CONDUCTOR, CHIP (2012)	
				R31	1-216-121-91	METAL GLAZE 1M	5% 1/10W
				R32	1-216-097-91	METAL GLAZE 100K	5% 1/10W
				R33	1-216-097-91	METAL GLAZE 100K	5% 1/10W
				R34	1-216-097-91	METAL GLAZE 100K	5% 1/10W

REF NO.	PART NO.	DESCRIPTION	REMARK	REF NO.	PART NO.	DESCRIPTION	REMARK				
R35	1-216-097-91	METAL GLAZE	100K	5%	1/10W	R111	1-216-061-00	METAL GLAZE	3.3K	5%	1/10W
R36	1-216-057-00	METAL GLAZE	2.2K	5%	1/10W	R112	1-216-065-00	METAL GLAZE	4.7K	5%	1/10W
R37	1-216-057-00	METAL GLAZE	2.2K	5%	1/10W	R113	1-216-061-00	METAL GLAZE	3.3K	5%	1/10W
R38	1-216-057-00	METAL GLAZE	2.2K	5%	1/10W	R114	1-216-033-00	METAL GLAZE	220	5%	1/10W
						R115	1-216-049-91	METAL GLAZE	1K	5%	1/10W
R39	1-216-628-11	METAL CHIP	110	0.50%	1/10W	R116	1-216-081-00	METAL GLAZE	22K	5%	1/10W
R40	1-216-628-11	METAL CHIP	110	0.50%	1/10W	R117	1-216-073-00	METAL GLAZE	10K	5%	1/10W
R41	1-216-097-91	METAL GLAZE	100K	5%	1/10W	R118	1-216-061-00	METAL GLAZE	3.3K	5%	1/10W
R42	1-216-097-91	METAL GLAZE	100K	5%	1/10W	R119	1-216-073-00	METAL GLAZE	10K	5%	1/10W
R43	1-216-097-91	METAL GLAZE	100K	5%	1/10W	R120	1-216-073-00	METAL GLAZE	10K	5%	1/10W
R44	1-216-097-91	METAL GLAZE	100K	5%	1/10W	R121	1-216-057-00	METAL GLAZE	2.2K	5%	1/10W
R45	1-216-097-91	METAL GLAZE	100K	5%	1/10W	R122	1-216-081-00	METAL GLAZE	22K	5%	1/10W
R46	1-216-097-91	METAL GLAZE	100K	5%	1/10W	R123	1-216-065-00	METAL GLAZE	4.7K	5%	1/10W
R47	1-216-097-91	METAL GLAZE	100K	5%	1/10W	R124	1-216-073-00	METAL GLAZE	10K	5%	1/10W
R48	1-216-097-91	METAL GLAZE	100K	5%	1/10W	R125	1-216-065-00	METAL GLAZE	4.7K	5%	1/10W
R51	1-216-049-91	METAL GLAZE	1K	5%	1/10W	R126	1-216-049-91	METAL GLAZE	1K	5%	1/10W
R52	1-216-049-91	METAL GLAZE	1K	5%	1/10W	R127	1-216-049-91	METAL GLAZE	1K	5%	1/10W
R53	1-216-049-91	METAL GLAZE	1K	5%	1/10W	R128	1-216-057-00	METAL GLAZE	2.2K	5%	1/10W
R54	1-216-049-91	METAL GLAZE	1K	5%	1/10W	R129	1-216-065-00	METAL GLAZE	4.7K	5%	1/10W
R55	1-216-049-91	METAL GLAZE	1K	5%	1/10W	R130	1-216-097-91	METAL GLAZE	100K	5%	1/10W
R56	1-216-049-91	METAL GLAZE	1K	5%	1/10W	R131	1-216-025-91	METAL GLAZE	100	5%	1/10W
R57	1-216-049-91	METAL GLAZE	1K	5%	1/10W	R132	1-216-081-00	METAL GLAZE	22K	5%	1/10W
R58	1-216-049-91	METAL GLAZE	1K	5%	1/10W	R133	1-216-065-00	METAL GLAZE	4.7K	5%	1/10W
R59	1-216-049-91	METAL GLAZE	1K	5%	1/10W	R134	1-216-097-91	METAL GLAZE	100K	5%	1/10W
R60	1-216-045-00	METAL GLAZE	680	5%	1/10W	R135	1-216-025-91	METAL GLAZE	100	5%	1/10W
R61	1-216-047-91	METAL GLAZE	820	5%	1/10W	R136	1-216-081-00	METAL GLAZE	22K	5%	1/10W
R62	1-216-053-00	METAL GLAZE	1.5k	5%	1/10W	R137	1-216-025-91	METAL GLAZE	100	5%	1/10W
R63	1-216-057-00	METAL GLAZE	2.2K	5%	1/10W	R138	1-216-081-00	METAL GLAZE	22K	5%	1/10W
R64	1-216-069-00	METAL GLAZE	6.8K	5%	1/10W	R139	1-216-065-00	METAL GLAZE	4.7K	5%	1/10W
R65	1-216-053-00	METAL GLAZE	1.5K	5%	1/10W	R140	1-216-097-91	METAL GLAZE	100K	5%	1/10W
R66	1-216-053-00	METAL GLAZE	1.5K	5%	1/10W	R141	1-216-025-91	METAL GLAZE	100	5%	1/10W
R67	1-216-053-00	METAL GLAZE	1.5K	5%	1/10W	R151	1-216-081-00	METAL GLAZE	22K	5%	1/10W
R68	1-216-053-00	METAL GLAZE	1.5K	5%	1/10W	R152	1-216-081-00	METAL GLAZE	22K	5%	1/10W
R69	1-216-053-00	METAL GLAZE	1.5K	5%	1/10W	R153	1-216-057-00	METAL GLAZE	2.2K	5%	1/10W
R70	1-216-049-91	METAL GLAZE	1K	5%	1/10W	R154	1-216-057-00	METAL GLAZE	2.2K	5%	1/10W
R71	1-216-049-91	METAL GLAZE	1K	5%	1/10W	R155	1-216-059-00	METAL GLAZE	2.7K	5%	1/10W
R72	1-216-655-11	METAL CHIP	1.5K	0.50%	1/10W	R156	1-164-004-11	CERAMIC CHIP	0.1	10%	25V
R73	1-216-097-91	METAL GLAZE	100K	5%	1/10W	R157	1-216-069-00	METAL GLAZE	6.8K	5%	1/10W
R74	1-216-073-00	METAL GLAZE	10K	5%	1/10W	R159	1-216-133-00	METAL GLAZE	3.3M		1/10W
R75	1-216-073-00	METAL GLAZE	10K	5%	1/10W	R161	1-216-057-00	METAL GLAZE	2.2K	5%	1/10W
R76	1-216-073-00	METAL GLAZE	10K	5%	1/10W	R162	1-216-065-00	METAL GLAZE	4.7K	5%	1/10W
R77	1-216-073-00	METAL GLAZE	10K	5%	1/10W	R163	1-216-065-00	METAL GLAZE	4.7K	5%	1/10W
R84	1-216-033-00	METAL GLAZE	220	5%	1/10W	R164	1-216-025-91	METAL GLAZE	100	5%	1/10W
R85	1-216-033-00	METAL GLAZE	220	5%	1/10W	R165	1-216-045-00	METAL GLAZE	680	5%	1/10W
R86	1-216-033-00	METAL GLAZE	220	5%	1/10W	R166	1-216-077-00	METAL GLAZE	15K	5%	1/10W
R87	1-216-033-00	METAL GLAZE	220	5%	1/10W	R167	1-216-077-00	METAL GLAZE	15K	5%	1/10W
R88	1-216-033-00	METAL GLAZE	220	5%	1/10W	R169	1-216-079-00	METAL GLAZE	18K	5%	1/10W
R89	1-216-033-00	METAL GLAZE	220	5%	1/10W	R170	1-216-079-00	METAL GLAZE	18K	5%	1/10W
R101	1-216-073-00	METAL GLAZE	10K	5%	1/10W	R171	1-216-073-00	METAL GLAZE	10K	5%	1/10W
R102	1-216-085-00	METAL GLAZE	33K	5%	1/10W	R172	1-216-073-00	METAL GLAZE	10K	5%	1/10W
R103	1-216-073-00	METAL GLAZE	10K	5%	1/10W	R181	1-216-113-00	METAL GLAZE	470K	5%	1/10W
R104	1-216-097-91	METAL GLAZE	100K	5%	1/10W	R182	1-216-073-00	METAL GLAZE	10K	5%	1/10W
R105	1-216-097-91	METAL GLAZE	100K	5%	1/10W	R183	1-216-113-00	METAL GLAZE	470K	5%	1/10W
R109	1-216-073-00	METAL GLAZE	10K	5%	1/10W	R184	1-216-099-00	METAL GLAZE	120K	5%	1/10W
R110	1-216-079-00	METAL GLAZE	18K	5%	1/10W	R185	1-216-057-00	METAL GLAZE	2.2K	5%	1/10W



REF NO.	PART NO.	DESCRIPTION	REMARK	REF NO.	PART NO.	DESCRIPTION	REMARK
R186	1-216-295-91	CONDUCTOR, CHIP (2012)		*4-050-795-01		SPACER, REAR PANEL	
R187	1-216-073-00	METAL GLAZE 10K	5% 1/10W	*4-050-805-01		SPRING, IC	
R189	1-216-073-00	METAL GLAZE 10K	5% 1/10W	*4-050-814-01		SHIELD, PCB	
R190	1-216-097-91	METAL GLAZE 100K	5% 1/10W	4-051-217-01		SHEET, RADIATION	
R191	1-216-121-91	METAL GLAZE 1M	5% 1/10W	4-051-217-01		SHEET, RADIATION	
R192	1-216-121-91	METAL GLAZE 1M	5% 1/10W	4-051-217-01		SHEET, RADIATION	
R193	1-216-121-91	METAL GLAZE 1M	5% 1/10W	*4-053-411-01		SHIELD (BK), PCB	
R194	1-216-097-91	METAL GLAZE 100K	5% 1/10W			(14E1E/14E1U/14E5E/14E5U/14F1E/14F1U/14F5E/14F5U)	
R195	1-216-097-91	METAL GLAZE 100K	5% 1/10W	4-382-854-01		SCREW (M3X8), P, SW (+)	
R196	1-216-097-91	METAL GLAZE 100K	5% 1/10W	4-382-854-01		SCREW (M3X8), P, SW (+)	
R197	1-216-097-91	METAL GLAZE 100K	5% 1/10W			(14E1E/14E1U/14E5E/14E5U/14F1E/14F1U/14F5E/14F5U)	
R198	1-216-097-91	METAL GLAZE 100K	5% 1/10W	*4-403-012-01		SPRING, STOPPER	
R199	1-216-097-91	METAL GLAZE 100K	5% 1/10W	4-623-699-01		SCREW (3X5)	
R201	1-216-073-00	METAL GLAZE 10K	5% 1/10W	*4-625-464-01		SUPPORT, FITTING, MB	
R202	1-216-041-00	METAL GLAZE 470	5% 1/10W			(14E1E/14E1U/14E5E/14E5U/14F1E/14F1U/14F5E/14F5U)	
		< VARIABLE RESISTOR >		7-682-566-04		SCREW +B 4X20	
RV101	1-238-092-11	RES, ADJ CERMET 47K		7-685-871-01		SCREW +BVTT 3X6 (S)	
		< SWITCH >		7-682-548-09		SCREW +BVTT 3X8 (S)	
S1	1-554-123-00	SWITCH, SLIDE (TERMINATE)				< CAPACITOR >	
		< TEST PIN >		C1	1-163-031-11	CERAMIC CHIP 0.01μ F	50V
TP1	1-537-864-11	PIN, POST		C3	1-163-031-11	CERAMIC CHIP 0.01μ F	50V
TP3	1-537-864-11	PIN, POST		C5	1-163-031-11	CERAMIC CHIP 0.01μ F	50V
TP5	1-537-864-11	PIN, POST		C7	1-163-031-11	CERAMIC CHIP 0.01μ F	50V
TP6	1-537-864-11	PIN, POST		C8	1-126-396-11	ELECT CHIP 47μ F	20% 16V
TP7	1-537-864-11	PIN, POST		C9	1-163-031-11	CERAMIC CHIP 0.01μ F	50V
TP8	1-537-864-11	PIN, POST		C11	1-126-396-11	ELECT CHIP 47μ F	20% 16V
TP9	1-537-864-11	PIN, POST		C12	1-126-396-11	ELECT CHIP 47μ F	20% 16V
TP10	1-537-864-11	PIN, POST		C13	1-126-396-11	ELECT CHIP 47μ F	20% 16V
		< CRYSTAL >		C14	1-126-397-11	ELECT CHIP 33μ F	20% 25V
X1	1-577-121-11	VIBRATOR, CRYSTAL (20MHz)		C15	1-163-031-11	CERAMIC CHIP 0.01μ F	50V
	3-741-396-01	INSULATOR (X1)		C100	1-163-227-11	CERAMIC CHIP 10pF	0.5pF 50V
X2	1-567-879-11	VIBRATOR, CRYSTAL (4.9152MHz)		C101	1-163-229-11	CERAMIC CHIP 12PpF	5% 50V
	3-741-396-01	INSULATOR (X2)		C102	1-115-155-11	ELECT CHIP 22μ F	20% 16V
X101	1-567-893-11	VIBRATOR, CRYSTAL (14.1875MHz)		C103	1-104-559-11	FILM CHIP 0.047μ F	5% 16V
	3-741-396-01	INSULATOR (X101)		C104	1-104-551-11	FILM CHIP 0.01μ F	5% 16V
X102	1-577-663-11	VIBRATOR, CRYSTAL (14.3181MHz)		C122	1-126-396-11	ELECT CHIP 47μ F	20% 16V
	3-741-396-01	INSULATOR (X102)		C128	1-104-752-11	TANTAL. CHIP 33μ F	20% 6.3V
X103	1-567-867-11	VIBRATOR, CRYSTAL (14.5MHz)		C129	1-164-505-11	CERAMIC CHIP 2.2μ F	16V
	3-741-396-01	INSULATOR (X103)		C130	1-164-505-11	CERAMIC CHIP 2.2μ F	16V
*****							
*A-1135-826-A		COMPLETE PCB, BK (20E1E/20E1U/20F1E/20F1U)		C140	1-163-031-11	CERAMIC CHIP 0.01μ F	50V
		*****		C141	1-163-031-11	CERAMIC CHIP 0.01μ F	50V
*A-1135-861-B		COMPLETE PCB, BK (14E1E/14E1U/14E5E/14E5U/14F1E/14F1U/14F5E/14F5U)		C142	1-104-559-11	FILM CHIP 0.047μ F	5% 16V
		*****		C143	1-104-551-11	FILM CHIP 0.01μ F	5% 16V
X-4033-103-1		HEATSINK ASSY (BK)		C144	1-163-031-11	CERAMIC CHIP 0.01μ F	50V
X-4033-103-1		HEATSINK ASSY (BK)		C145	1-163-031-11	CERAMIC CHIP 0.01μ F	50V
*X-4033-105-1		PANEL (BK) ASSY, CONNECTOR		C146	1-126-392-11	ELECT CHIP 100μ F	20% 6.3V
*3-648-057-00		NUT (IS04), U		C147	1-126-392-11	ELECT CHIP 100μ F	20% 6.3V
				C154	1-126-390-11	ELECT CHIP 22μ F	20% 6.3V
				C160	1-163-031-11	CERAMIC CHIP 0.01μ F	50V
				C161	1-163-031-11	CERAMIC CHIP 0.01μ F	50V
				C162	1-163-249-11	CERAMIC CHIP 82pF	5% 50V
				C163	1-163-089-00	CERAMIC CHIP 6pF	0.5pF 50V
				C164	1-163-031-11	CERAMIC CHIP 0.01μ F	50V

REF NO.	PART NO.	DESCRIPTION	REMARK	REF NO.	PART NO.	DESCRIPTION	REMARK		
C165	1-164-222-11	CERAMIC CHIP	0.22μ F	25V	C323	1-164-505-11	CERAMIC CHIP	2.2μ F	16V
C166	1-164-700-11	CERAMIC CHIP	0.68μ F	16V	C324	1-163-031-11	CERAMIC CHIP	0.01μ F	50V
C167	1-164-505-11	CERAMIC CHIP	2.2μ F	50V	C326	1-164-222-11	CERAMIC CHIP	0.22μ F	25V
C168	1-104-559-11	FILM CHIP	0.047μ F	5% 16V	C327	1-104-559-11	FILM CHIP	0.047μ F	5% 16V
C169	1-104-559-11	FILM CHIP	0.047μ F	5% 16V	C328	1-104-752-11	TANTAL. CHIP	33μ F	20% 6.3V
C170	1-164-336-11	CERAMIC CHIP	0.33μ F	25V	C329	1-164-505-11	CERAMIC CHIP	2.2μ F	16V
C171	1-163-031-11	CERAMIC CHIP	0.01μ F	50V	C330	1-164-505-11	CERAMIC CHIP	2.2μ F	16V
C172	1-104-823-11	TANTAL. CHIP	47μ F	20% 16V	C350	1-163-031-11	CERAMIC CHIP	0.01μ F	50V
C173	1-164-005-11	CERAMIC CHIP	0.47μ F	25V	C351	1-163-031-11	CERAMIC CHIP	0.01μ F	50V
C174	1-164-505-11	CERAMIC CHIP	2.2μ F	16V	C352	1-104-559-11	FILM CHIP	0.047μ F	5% 16V
C175	1-164-505-11	CERAMIC CHIP	2.2μ F	16V	C353	1-104-551-11	FILM CHIP	0.01μ F	5% 16V
C176	1-104-559-11	FILM CHIP	0.047μ F	5% 16V	C354	1-163-031-11	CERAMIC CHIP	0.01μ F	50V
C177	1-163-031-11	CERAMIC CHIP	0.01μ F	50V	C355	1-163-031-11	CERAMIC CHIP	0.01μ F	50V
C178	1-163-031-11	CERAMIC CHIP	0.01μ F	50V	C356	1-126-392-11	ELECT CHIP	100μ F	20% 6.3V
C179	1-163-031-11	CERAMIC CHIP	0.01μ F	50V	C357	1-126-392-11	ELECT CHIP	100μ F	20% 6.3V
C180	1-163-031-11	CERAMIC CHIP	0.01μ F	50V	C360	1-163-031-11	CERAMIC CHIP	0.01μ F	50V
C181	1-104-551-11	FILM CHIP	0.01μ F	5% 16V	C361	1-163-031-11	CERAMIC CHIP	0.01μ F	50V
C182	1-104-559-11	FILM CHIP	0.047μ F	5% 16V	C362	1-163-249-11	CERAMIC CHIP	82pF	5% 50V
C183	1-163-033-91	CERAMIC CHIP	0.022μ F	50V	C363	1-163-089-00	CERAMIC CHIP	6pF	0.5pF 50V
C187	1-163-031-11	CERAMIC CHIP	0.01μ F	50V	C374	1-164-222-11	CERAMIC CHIP	0.22μ F	25V
C188	1-163-038-91	CERAMIC CHIP	0.1μ F	25V	C375	1-164-700-11	CERAMIC CHIP	0.68μ F	16V
C189	1-163-031-11	CERAMIC CHIP	0.01μ F	50V	C376	1-164-505-11	CERAMIC CHIP	2.2μ F	16V
C190	1-164-222-11	CERAMIC CHIP	0.22μ F	25V	C377	1-163-031-11	CERAMIC CHIP	0.01μ F	50V
C191	1-163-251-11	CERAMIC CHIP	100pF	5% 50V	C378	1-104-559-11	FILM CHIP	0.047μ F	5% 16V
C192	1-164-232-11	CERAMIC CHIP	0.01μ F	10% 50V	C379	1-104-559-11	FILM CHIP	0.047μ F	5% 16V
C193	1-163-035-00	CERAMIC CHIP	2.2μ F	50V	C380	1-164-336-11	CERAMIC CHIP	0.33μ F	25V
C194	1-106-367-00	MYLAR	0.01μ F	10% 200V	C381	1-163-031-11	CERAMIC CHIP	0.01μ F	50V
C195	1-164-505-11	CERAMIC CHIP	2.2μ F	16V	C382	1-104-823-11	TANTAL. CHIP	47μ F	20% 16V
C196	1-107-943-11	ELECT	10μ F	20% 160V	C383	1-164-005-11	CERAMIC CHIP	0.47μ F	25V
C197	1-163-031-11	CERAMIC CHIP	0.01μ F	50V	C384	1-163-505-11	CERAMIC CHIP	2.2μ F	16V
C198	1-163-031-11	CERAMIC CHIP	0.01μ F	50V	C385	1-164-505-11	CERAMIC CHIP	2.2μ F	16V
C199	1-163-031-11	CERAMIC CHIP	0.01μ F	50V	C386	1-104-559-11	FILM CHIP	0.047μ F	5% 16V
C200	1-164-505-11	CERAMIC CHIP	2.2μ F	16V	C387	1-163-031-11	CERAMIC CHIP	0.01μ F	50V
C201	1-163-031-11	CERAMIC CHIP	0.01μ F	50V	C388	1-163-031-11	CERAMIC CHIP	0.01μ F	50V
C202	1-163-031-11	CERAMIC CHIP	0.01μ F	50V	C389	1-163-031-11	CERAMIC CHIP	0.01μ F	50V
C203	1-163-031-11	CERAMIC CHIP	0.01μ F	50V	C390	1-163-031-11	CERAMIC CHIP	0.01μ F	50V
C204	1-163-031-11	CERAMIC CHIP	0.01μ F	50V	C391	1-104-551-11	FILM CHIP	0.01μ F	5% 16V
C220	1-163-127-00	CERAMIC CHIP	270pF	5% 50V	C392	1-104-559-11	FILM CHIP	0.047μ F	5% 16V
C230	1-126-392-11	ELECT CHIP	100μ F	20% 6.3V	C393	1-163-033-91	CERAMIC CHIP	0.022μ F	50V
C231	1-126-391-11	ELECT CHIP	47μ F	20% 6.3V	C397	1-163-031-11	CERAMIC CHIP	0.01μ F	50V
C232	1-126-391-11	ELECT CHIP	47μ F	20% 6.3V	C398	1-163-038-91	CERAMIC CHIP	0.1μ F	25V
C240	1-163-031-11	CERAMIC CHIP	0.01μ F	50V	C399	1-163-031-11	CERAMIC CHIP	0.01μ F	50V
C300	1-163-227-11	CERAMIC CHIP	10pF	0.5pF 50V	C400	1-164-222-11	CERAMIC CHIP	0.22μ F	25V
C301	1-163-229-11	CERAMIC CHIP	12pF	5% 50V	C401	1-163-251-11	CERAMIC CHIP	100pF	5% 50V
C302	1-115-155-21	ELECT CHIP	22μ F	20% 16V	C402	1-164-232-11	CERAMIC CHIP	0.01μ F	10% 50V
C303	1-164-505-11	CERAMIC CHIP	2.2μ F	16V	C403	1-163-035-00	CERAMIC CHIP	0.047μ F	50V
C304	1-104-559-11	FILM CHIP	0.047μ F	5% 16V	C404	1-106-367-00	MYLAR	0.01μ F	10% 200V
C305	1-104-551-11	FILM CHIP	0.01μ F	5% 16V	C405	1-164-505-11	CERAMIC CHIP	2.2μ F	16V
C307	1-164-505-11	CERAMIC CHIP	2.2μ F	16V	C406	1-107-943-11	ELECT	10μ F	20% 160V
C308	1-164-700-11	CERAMIC CHIP	0.68μ F	16V	C407	1-163-031-11	CERAMIC CHIP	0.01μ F	50V
C309	1-104-559-11	FILM CHIP	0.047μ F	5% 16V	C409	1-164-505-11	CERAMIC CHIP	2.2μ F	16V
C310	1-163-031-11	CERAMIC CHIP	0.01μ F	50V	C410	1-163-031-11	CERAMIC CHIP	0.01μ F	50V
C311	1-163-031-11	CERAMIC CHIP	0.01μ F	50V	C411	1-163-031-11	CERAMIC CHIP	0.01μ F	50V
C322	1-126-392-11	ELECT CHIP	100μ F	20% 6.3V	C412	1-163-031-11	CERAMIC CHIP	0.01μ F	50V

**BK**

REF NO.	PART NO.	DESCRIPTION	REMARK	REF NO.	PART NO.	DESCRIPTION	REMARK
C420	1-163-127-00	CERAMIC CHIP	270pF 5% 50V	C583	1-163-031-11	CERAMIC CHIP	0.01μ F 50V
C421	1-126-390-11	ELECT CHIP	22μ F 20% 6.3V	C584	1-104-551-11	FILM CHIP	0.01μ F 5% 16V
C430	1-126-392-11	ELECT CHIP	100μ F 20% 6.3V	C585	1-104-559-11	FILM CHIP	0.047μ F 5% 16V
C431	1-126-391-11	ELECT CHIP	47μ F 20% 6.3V	C586	1-163-033-91	CERAMIC CHIP	0.022μ F 50V
C432	1-126-391-11	ELECT CHIP	47μ F 20% 6.3V	C590	1-163-031-11	CERAMIC CHIP	0.01μ F 50V
C440	1-163-031-11	CERAMIC CHIP	0.01μ F 50V	C591	1-163-038-91	CERAMIC CHIP	0.1μ F 25V
C500	1-163-227-11	CERAMIC CHIP	10pF 0.5pF 50V	C592	1-163-031-11	CERAMIC CHIP	0.01μ F 50V
C501	1-163-229-11	CERAMIC CHIP	12pF 5% 50V	C593	1-164-222-11	CERAMIC CHIP	0.22μ F 25V
C502	1-115-155-21	ELECT CHIP	22μ F 20% 16V	C594	1-163-251-11	CERAMIC CHIP	100pF 5% 50V
C503	1-164-505-11	CERAMIC CHIP	2.2μ F 16V	C595	1-164-232-11	CERAMIC CHIP	0.01μ F 10% 50V
C504	1-104-559-11	FILM CHIP	0.047μ F 5% 16V	C596	1-163-035-00	CERAMIC CHIP	0.047μ F 50V
C505	1-104-551-11	FILM CHIP	0.01μ F 5% 16V	C597	1-106-367-00	MYLAR	0.01μ F 10% 200V
C507	1-164-505-11	CERAMIC CHIP	2.2μ F 16V	C598	1-164-505-11	CERAMIC CHIP	2.2μ F 16V
C508	1-164-505-11	CERAMIC CHIP	22μ F 16V	C599	1-107-943-11	ELECT	10μ F 20% 160V
C509	1-164-700-11	CERAMIC CHIP	0.68μ F 16V	C600	1-163-031-11	CERAMIC CHIP	0.01μ F 50V
C510	1-104-559-11	FILM CHIP	0.047μ F 5% 16V	C601	1-163-031-11	CERAMIC CHIP	0.01μ F 50V
C520	1-164-505-11	CERAMIC CHIP	2.2μ F 16V	C602	1-164-505-11	CERAMIC CHIP	2.2μ F 16V
C523	1-164-505-11	CERAMIC CHIP	2.2μ F 16V	C603	1-163-031-11	CERAMIC CHIP	0.01μ F 50V
C524	1-163-031-11	CERAMIC CHIP	0.01μ F 50V	C604	1-164-505-11	CERAMIC CHIP	2.2μ F 16V
C526	1-164-222-11	CERAMIC CHIP	0.22μ F 25V	C605	1-163-031-11	CERAMIC CHIP	0.01μ F 50V
C527	1-104-559-11	FILM CHIP	0.047μ F 5% 16V	C620	1-163-127-00	CERAMIC CHIP	270pF 5% 50V
C528	1-104-752-11	TANTAL. CHIP	33μ F 20% 6.3V	C621	1-164-505-11	CERAMIC CHIP	2.2μ F 16V
C529	1-164-505-11	CERAMIC CHIP	2.2μ F 16V	C630	1-126-392-11	ELECT CHIP	100μ F 20% 6.3V
C530	1-164-505-11	CERAMIC CHIP	2.2μ F 16V	C631	1-126-391-11	ELECT CHIP	47μ F 20% 6.3V
C540	1-163-031-11	CERAMIC CHIP	0.01μ F 50V	C632	1-126-391-11	ELECT CHIP	47μ F 20% 6.3V
C541	1-163-031-11	CERAMIC CHIP	0.01μ F 50V	C640	1-163-031-11	CERAMIC CHIP	0.01μ F 50V
C542	1-104-559-11	FILM CHIP	0.047μ F 5% 16V	C700	1-104-539-11	FILM CHIP	0.001μ F 5% 50V
C543	1-104-551-11	FILM CHIP	0.01μ F 5% 16V	C701	1-104-539-11	FILM CHIP	0.001μ F 5% 50V
C544	1-163-031-11	CERAMIC CHIP	0.01μ F 50V	C702	1-163-031-11	CERAMIC CHIP	0.01μ F 50V
C545	1-163-031-11	CERAMIC CHIP	0.01μ F 50V	C703	1-163-031-11	CERAMIC CHIP	0.01μ F 50V
C546	1-126-392-11	ELECT CHIP	100μ F 20% 6.3V	C704	1-126-391-11	ELECT CHIP	47μ F 20% 6.3V
C547	1-126-392-11	ELECT CHIP	100μ F 20% 6.3V	C705	1-163-031-11	CERAMIC CHIP	0.01μ F 50V
C548	1-126-392-11	ELECT CHIP	100μ F 20% 6.3V	C706	1-107-905-11	ELECT	4.7μ F 20% 50V
C549	1-126-392-11	ELECT CHIP	100μ F 20% 6.3V	C707	1-163-031-11	CERAMIC CHIP	0.01μ F 50V
C560	1-163-031-11	CERAMIC CHIP	0.01μ F 50V	C708	1-115-153-11	ELECT CHIP	4.7μ F 20% 16V
C561	1-163-031-11	CERAMIC CHIP	0.01μ F 50V	C709	1-107-960-11	ELECT	4.7μ F 20% 160V
C562	1-163-249-11	CERAMIC CHIP	82pF 5% 50V	C710	1-106-367-00	MYLAR	0.01μ F 10% 200V
C563	1-163-089-00	CERAMIC CHIP	6pF 0.5pF 50V	C711	1-107-943-11	ELECT	10μ F 20% 160V
C567	1-164-222-11	CERAMIC CHIP	0.22μ F 25V	C712	1-164-505-11	CERAMIC CHIP	2.2μ F 16V
C568	1-164-700-11	CERAMIC CHIP	0.68μ F 16V	C713	1-164-505-11	CERAMIC CHIP	2.2μ F 16V
C569	1-164-505-11	CERAMIC CHIP	2.2μ F 16V	C728	1-163-009-11	CERAMIC CHIP	0.001μ F 10% 50V
C570	1-163-031-11	CERAMIC CHIP	0.01μ F 50V	C729	1-104-563-11	FILM CHIP	0.1μ F 5% 16V
C571	1-104-559-11	FILM CHIP	0.047μ F 5% 16V	C734	1-164-505-11	CERAMIC CHIP	2.2μ F 16V
C572	1-104-559-11	FILM CHIP	0.047μ F 5% 16V	C751	1-126-396-11	ELECT CHIP	47μ F 20% 16V
C573	1-164-336-11	CERAMIC CHIP	0.33μ F 25V	C770	1-163-031-11	CERAMIC CHIP	0.01μ F 50V
C574	1-163-031-11	CERAMIC CHIP	0.01μ F 50V	C782	1-163-031-11	CERAMIC CHIP	0.01μ F 50V
C575	1-104-823-11	TANTAL. CHIP	47μ F 20% 16V	C783	1-163-031-11	CERAMIC CHIP	0.01μ F 50V
C576	1-164-005-11	CERAMIC CHIP	0.47μ F 25V	C800	1-163-229-11	CERAMIC CHIP	12pF 5% 50V
C577	1-164-505-11	CERAMIC CHIP	2.2μ F 16V	C801	1-163-229-11	CERAMIC CHIP	12pF 5% 50V
C578	1-164-505-11	CERAMIC CHIP	2.2μ F 16V	C802	1-163-031-11	CERAMIC CHIP	0.01μ F 50V
C579	1-104-559-11	FILM CHIP	0.047μ F 5% 16V	C803	1-163-031-11	CERAMIC CHIP	0.01μ F 50V
C580	1-163-031-11	CERAMIC CHIP	0.01μ F 50V	C804	1-115-155-11	ELECT CHIP	22μ F 20% 16V
C581	1-163-031-11	CERAMIC CHIP	0.01μ F 50V	C805	1-163-031-11	CERAMIC CHIP	0.01μ F 50V
C582	1-163-031-11	CERAMIC CHIP	0.01μ F 50V	C806	1-163-031-11	CERAMIC CHIP	0.01μ F 50V



REF NO.	PART NO.	DESCRIPTION	REMARK	REF NO.	PART NO.	DESCRIPTION	REMARK				
C807	1-163-031-11	CERAMIC CHIP	0.01μ F	50V	C926	1-163-031-11	CERAMIC CHIP	0.01μ F	50V		
C808	1-163-031-11	CERAMIC CHIP	0.01μ F	50V	C927	1-126-391-11	ELECT CHIP	47μ F	20%	6.3V	
C809	1-163-031-11	CERAMIC CHIP	0.01μ F	50V	C928	1-164-346-11	CERAMIC CHIP	1μ F		16V	
C810	1-163-031-11	CERAMIC CHIP	0.01μ F	50V	C929	1-126-391-11	ELECT CHIP	47μ F	20%	6.3V	
C812	1-163-031-11	CERAMIC CHIP	0.01μ F	50V	C930	1-126-390-11	ELECT CHIP	22μ F	20%	6.3V	
C813	1-126-394-11	ELECT CHIP	10μ F	20%	16V	C931	1-163-038-91	CERAMIC CHIP	0.1μ F		25V
C814	1-163-117-00	CERAMIC CHIP	100pF	5%	50V	C1000	1-163-031-11	CERAMIC CHIP	0.01μ F		50V
C815	1-163-257-11	CERAMIC CHIP	180pF	5%	50V	C1001	1-126-392-11	ELECT CHIP	100μ F	20%	6.3V
C816	1-163-117-00	CERAMIC CHIP	100pF	5%	50V	C1002	1-163-031-11	CERAMIC CHIP	0.01μ F		50V
C817	1-163-038-91	CERAMIC CHIP	0.1μ F		25V	C1003	1-163-031-11	CERAMIC CHIP	0.01μ F		50V
C818	1-126-390-11	ELECT CHIP	22μ F	20%	6.3V	C1004	1-164-505-11	CERAMIC CHIP	2.2μ F		16V
C819	1-163-031-11	CERAMIC CHIP	0.01μ F		50V	C1005	1-163-031-11	CERAMIC CHIP	0.01μ F		50V
C820	1-163-038-91	CERAMIC CHIP	0.1μ F		25V	C1006	1-163-031-11	CERAMIC CHIP	0.01μ F		50V
C821	1-163-038-91	CERAMIC CHIP	0.1μ F		25V	C1007	1-163-031-11	CERAMIC CHIP	0.01μ F		50V
C822	1-163-038-91	CERAMIC CHIP	0.1μ F		25V	C1008	1-163-031-11	CERAMIC CHIP	0.01μ F		50V
C823	1-128-235-11	ELECT CHIP	0.47μ F	20%	50V	C1009	1-163-031-11	CERAMIC CHIP	0.01μ F		50V
C824	1-164-346-11	CERAMIC CHIP	1μ F		16V	C1010	1-163-031-11	CERAMIC CHIP	0.01μ F		50V
C825	1-163-121-00	CERAMIC CHIP	150pF	5%	50V	C1011	1-164-505-11	CERAMIC CHIP	2.2μ F		16V
C826	1-163-113-00	CERAMIC CHIP	68pF	5%	50V	C1012	1-163-031-11	CERAMIC CHIP	0.01μ F		50V
C827	1-163-031-11	CERAMIC CHIP	0.01μ F		50V	C1013	1-163-031-11	CERAMIC CHIP	0.01μ F		50V
C828	1-163-133-00	CERAMIC CHIP	470pF	5%	50V	C1014	1-164-505-11	CERAMIC CHIP	2.2μ F		16V
C829	1-163-017-00	CERAMIC CHIP	0.0047μ F	10%	50V	C1015	1-163-031-11	CERAMIC CHIP	0.01μ F		50V
C830	1-163-133-00	CERAMIC CHIP	470pF	5%	50V	C1016	1-163-031-11	CERAMIC CHIP	0.01μ F		50V
C831	1-163-017-00	CERAMIC CHIP	0.0047μ F	10%	50V	C1017	1-164-505-11	CERAMIC CHIP	2.2μ F		16V
C832	1-163-133-00	CERAMIC CHIP	470pF	5%	50V	C1019	1-163-031-11	CERAMIC CHIP	0.01μ F		50V
C833	1-163-133-00	CERAMIC CHIP	470pF	5%	50V	C1020	1-164-505-11	CERAMIC CHIP	2.2μ F		16V
C834	1-163-133-00	CERAMIC CHIP	470pF	5%	50V	C1021	1-163-031-11	CERAMIC CHIP	0.01μ F		50V
C835	1-163-117-00	CERAMIC CHIP	100pF	5%	50V	C1022	1-163-031-11	CERAMIC CHIP	0.01μ F		50V
C836	1-163-133-00	CERAMIC CHIP	470pF	5%	50V	C1023	1-164-505-11	CERAMIC CHIP	2.2μ F		16V
C837	1-164-222-11	CERAMIC CHIP	0.22μ F		25V	C1024	1-163-031-11	CERAMIC CHIP	0.01μ F		50V
C838	1-164-222-11	CERAMIC CHIP	0.22μ F		25V	C1025	1-163-031-11	CERAMIC CHIP	0.01μ F		50V
C847	1-163-031-11	CERAMIC CHIP	0.01μ F		50V	C1026	1-163-031-11	CERAMIC CHIP	0.01μ F		50V
C850	1-126-392-11	ELECT CHIP	100μ F	20%	6.3V	C1027	1-126-396-11	ELECT CHIP	47μ F	20%	16V
C851	1-126-168-11	ELECT	1000μ F	20%	6.3V	C1028	1-163-031-11	CERAMIC CHIP	0.01μ F		50V
C852	1-126-391-11	ELECT CHIP	47μ F	20%	6.3V	C1029	1-163-031-11	CERAMIC CHIP	0.01μ F		50V
C853	1-126-168-11	ELECT	1000μ F	20%	6.3V	C1030	1-163-031-11	CERAMIC CHIP	0.01μ F		50V
C863	1-163-031-11	CERAMIC CHIP	0.01μ F		50V	C1031	1-163-031-11	CERAMIC CHIP	0.01μ F		50V
C900	1-163-031-11	CERAMIC CHIP	0.01μ F		50V	C1032	1-163-031-11	CERAMIC CHIP	0.01μ F		50V
C901	1-163-031-11	CERAMIC CHIP	0.01μ F		50V	C1033	1-163-031-11	CERAMIC CHIP	0.01μ F		50V
C902	1-163-031-11	CERAMIC CHIP	0.01μ F		50V	C1034	1-163-031-11	CERAMIC CHIP	0.01μ F		50V
C903	1-163-031-11	CERAMIC CHIP	0.01μ F		50V	C1035	1-163-031-11	CERAMIC CHIP	0.01μ F		50V
C904	1-163-031-11	CERAMIC CHIP	0.01μ F		50V	C1036	1-163-031-11	CERAMIC CHIP	0.01μ F		50V
C905	1-163-031-11	CERAMIC CHIP	0.01μ F		50V	C1037	1-164-505-11	CERAMIC CHIP	2.2μ F		16V
C907	1-163-031-11	CERAMIC CHIP	0.01μ F		50V	C1038	1-163-031-11	CERAMIC CHIP	0.01μ F		50V
C908	1-163-031-11	CERAMIC CHIP	0.01μ F		50V	C1039	1-163-031-11	CERAMIC CHIP	0.01μ F		50V
C909	1-163-031-11	CERAMIC CHIP	0.01μ F		50V	C1200	1-163-031-11	CERAMIC CHIP	0.01μ F		50V
C910	1-163-031-11	CERAMIC CHIP	0.01μ F		50V	C1201	1-126-392-11	ELECT CHIP	100μ F	20%	6.3V
C911	1-163-031-11	CERAMIC CHIP	0.01μ F		50V	C1208	1-164-505-11	CERAMIC CHIP	2.2μ F		16V
C914	1-163-031-11	CERAMIC CHIP	0.01μ F		50V	C1209	1-164-505-11	CERAMIC CHIP	2.2μ F		16V
C915	1-163-031-11	CERAMIC CHIP	0.01μ F		50V	C1210	1-163-031-11	CERAMIC CHIP	0.01μ F		50V
C917	1-163-031-11	CERAMIC CHIP	0.01μ F		50V	C1211	1-163-031-11	CERAMIC CHIP	0.01μ F		50V
C918	1-164-161-11	CERAMIC CHIP	0.0022μ F	10%	50V	C1213	1-164-505-11	CERAMIC CHIP	2.2μ F		16V
C921	1-163-031-11	CERAMIC CHIP	0.01μ F		50V	C1215	1-163-031-11	CERAMIC CHIP	0.01μ F		50V
C924	1-126-391-11	ELECT CHIP	47μ F	20%	6.3V	C1216	1-163-031-11	CERAMIC CHIP	0.01μ F		50V
C925	1-126-391-11	ELECT CHIP	47μ F	20%	6.3V	C1217	1-163-031-11	CERAMIC CHIP	0.01μ F		50V

**BK**

REF NO.	PART NO.	DESCRIPTION	REMARK	REF NO.	PART NO.	DESCRIPTION	REMARK
C1218	1-164-505-11	CERAMIC CHIP	2.2μ F	16V	D567	8-719-016-74	DIODE 1SS352
C1222	1-164-505-11	CERAMIC CHIP	2.2μ F	16V	D568	8-719-016-74	DIODE 1SS352
C1223	1-164-505-11	CERAMIC CHIP	2.2μ F	16V	D569	8-719-157-72	DIODE RD22M-B
C1224	1-163-031-11	CERAMIC CHIP	0.01μ F	50V	D570	8-719-901-83	DIODE 1SS83
C1225	1-163-031-11	CERAMIC CHIP	0.01μ F	50V	D571	8-719-901-83	DIODE 1SS83
C1227	1-164-505-11	CERAMIC CHIP	2.2μ F	16V	D600	8-719-016-74	DIODE 1SS352
C1229	1-163-031-11	CERAMIC CHIP	0.01μ F	50V	D601	8-719-106-16	DIODE RD6.8M-B1
C1230	1-163-031-11	CERAMIC CHIP	0.01μ F	50V	D802	8-719-016-74	DIODE 1SS352
C1231	1-163-031-11	CERAMIC CHIP	0.01μ F	50V	D803	8-719-016-74	DIODE 1SS352
C1235	1-164-505-11	CERAMIC CHIP	2.2μ F	16V	D804	8-719-016-74	DIODE 1SS352
C1236	1-164-505-11	CERAMIC CHIP	2.2μ F	16V	D805	8-719-016-74	DIODE 1SS352
C1237	1-163-031-11	CERAMIC CHIP	0.01μ F	50V	D900	8-719-158-15	DIODE RD5.6S-B
C1238	1-163-031-11	CERAMIC CHIP	0.01μ F	50V	D901	8-719-016-74	DIODE 1SS352
C1240	1-164-505-11	CERAMIC CHIP	2.2μ F	16V	D902	8-719-016-74	DIODE 1SS352
C1242	1-163-031-11	CERAMIC CHIP	0.01μ F	50V	D903	8-719-016-74	DIODE 1SS352
C1243	1-163-031-11	CERAMIC CHIP	0.01μ F	50V	D904	8-719-016-74	DIODE 1SS352
C1244	1-163-031-11	CERAMIC CHIP	0.01μ F	50V	D905	8-719-016-74	DIODE 1SS352
C1245	1-163-031-11	CERAMIC CHIP	0.01μ F	50V			
C1246	1-163-031-11	CERAMIC CHIP	0.01μ F	50V			
C1247	1-126-396-11	ELECT CHIP	47μ F	20% 16V			< FILTER >
C1248	1-163-031-11	CERAMIC CHIP	0.01μ F		FL900	1-239-480-11	FILTER, EMI
		< CONNECTOR >			FL901	1-239-480-11	FILTER, EMI
CN1	1-774-523-11	PIN, CONNECTOR (PC BOARD) 64P			FL902	1-239-183-11	FILTER, EMI
CN2	*1-564-507-11	PLUG, CONNECTOR 4P					< IC >
CN3	*1-564-507-11	PLUG, CONNECTOR 4P			IC1	8-759-144-82	IC μ PC2405HF
CN4	*1-564-507-11	PLUG, CONNECTOR 4P			IC2	8-759-247-67	IC LM2990T-5.0
CN5	*1-564-506-11	PLUG, CONNECTOR 3P			IC3	8-759-701-88	IC NJM7912FA
		< TRIMMER >			IC101	8-759-011-65	IC MC74HC4053F
CV100	1-141-422-11	CAP, ADJ			IC102	8-759-981-48	IC TL082M
CV300	1-141-422-11	CAP, ADJ			IC104	8-759-011-65	IC MC74HC4053F
CV500	1-141-422-11	CAP, ADJ			IC106	8-759-981-48	IC TL082M
		< DIODE >			IC107	8-759-082-61	IC TC4W53FU
D102	8-719-016-74	DIODE 1SS352			IC110	8-759-011-65	IC MC74HC4053F
D103	8-719-016-74	DIODE 1SS352			IC111	8-759-981-48	IC TL082M
D164	8-719-016-74	DIODE 1SS352			IC112	8-752-054-80	IC CXA1521M
D165	8-719-016-74	DIODE 1SS352			IC113	8-759-011-65	IC MC74HC4053F
D166	8-719-157-72	DIODE RD22M-B			IC114	8-759-981-48	IC TL082M
D167	8-719-901-83	DIODE 1SS83			IC115	8-759-700-95	IC NJM1496M
D168	8-719-901-83	DIODE 1SS83			IC116	8-759-011-63	IC MC74HC4051F
D200	8-719-016-74	DIODE 1SS352			IC117	8-759-011-65	IC MC74HC4053F
D201	8-719-106-16	DIODE RD6.8M-B1			IC118	8-759-981-48	IC TL082M
D302	8-719-016-74	DIODE 1SS352			IC119	8-759-073-90	IC TDA6111Q
D303	8-719-016-74	DIODE 1SS352			IC121	8-759-981-48	IC TL082M
D374	8-719-016-74	DIODE 1SS352			IC122	8-759-981-48	IC TL082M
D375	8-719-016-74	DIODE 1SS352			IC123	8-759-981-48	IC TL082M
D376	8-719-157-72	DIODE RD22M-B			IC124	8-759-011-65	IC MC74HC4053F
D377	8-719-901-83	DIODE 1SS83			IC126	8-759-011-65	IC MC74HC4053F
D378	8-719-901-83	DIODE 1SS83			IC127	8-759-981-48	IC TL082M
D400	8-719-016-74	DIODE 1SS352			IC128	8-759-981-48	IC TL082M
D401	8-719-106-16	DIODE RD6.8M-B1			IC129	8-759-988-13	IC LM393PS
D502	8-719-016-74	DIODE 1SS352			IC130	8-759-082-61	IC TC4W53FU
D503	8-719-016-74	DIODE 1SS352			IC131	8-759-058-64	IC TC7S32FU(TE85R)
					IC300	8-759-981-48	IC TL082M
					IC301	8-759-011-65	IC MC74HC4053F

REF NO.	PART NO.	DESCRIPTION	REMARK	REF NO.	PART NO.	DESCRIPTION	REMARK
IC302	8-759-981-48	IC TL082M		IC528	8-759-981-48	IC TL082M	
IC303	8-752-054-80	IC CXA1521M		IC529	8-759-988-13	IC LM393PS	
IC304	8-759-011-65	IC MC74HC4053F		IC530	8-759-082-61	IC TC4W53FU	
IC305	8-752-053-21	IC CXA1211M		IC531	8-759-058-64	IC TC7S32FU(TE85R)	
IC306	8-759-981-48	IC TL082M		IC700	8-759-988-13	IC LM393PS	
IC307	8-759-082-61	IC TC4W53FU		IC701	8-759-011-65	IC MC74HC4053F	
IC310	8-759-011-65	IC MC74HC4053F		IC702	8-759-011-64	IC MC74HC4052F	
IC311	8-759-981-48	IC TL082M		IC703	8-759-988-13	IC LM393PS	
IC312	8-752-054-80	IC CXA1521M		IC704	8-759-981-48	IC TL082M	
IC313	8-759-011-65	IC MC74HC4053F		IC705	8-759-981-48	IC TL082M	
IC314	8-759-981-48	IC TL082M		IC706	8-759-346-42	IC TDA6101Q/N3	
IC315	8-759-700-95	IC NJM1496M		IC728	8-759-032-01	IC MC74HC00AF	
IC316	8-759-011-63	IC MC74HC4051F		IC730	8-759-925-72	IC SN74HC02ANS	
IC317	8-759-011-65	IC MC74HC4053F		IC731	8-759-925-80	IC SN74HC14ANS	
IC318	8-759-981-48	IC TL082M		IC732	8-759-007-80	IC MC74HC175F	
IC319	8-759-073-90	IC TDA6111Q		IC734	8-759-007-50	IC MC74HC11F	
IC320	8-759-981-48	IC TL082M		IC735	8-759-925-72	IC SN74HC02ANS	
IC321	8-759-981-48	IC TL082M		IC736	8-759-925-72	IC SN74HC02ANS	
IC322	8-759-981-48	IC TL082M		IC800	8-759-011-65	IC MC74HC4053F	
IC323	8-759-981-48	IC TL082M		IC801	8-759-008-45	IC MC74HC4538F	
IC324	8-759-011-65	IC MC74HC4053F		IC802	8-759-100-96	IC $\mu$ PC4558G2	
IC325	8-759-082-61	IC TC4W53FU		IC803	8-759-008-45	IC MC74HC4538F	
IC326	8-759-011-65	IC MC74HC4053F		IC804	8-759-008-45	IC MC74HC4538F	
IC327	8-759-981-48	IC TL082M		IC805	8-759-058-55	IC TC7S02FU-TE85L	
IC328	8-759-981-48	IC TL082M		IC900	8-759-032-26	IC MC74HC125AF	
IC329	8-759-988-13	IC LM393PS		IC901	8-759-981-48	IC TL082M	
IC330	8-759-082-61	IC TC4W53FU		IC902	8-759-346-47	IC MB89613R-236	
IC331	8-759-058-64	IC TC7S32FU(TE85R)		IC903	8-759-156-54	IC X25040SI	
IC500	8-759-011-65	IC MC74HC4053F		IC904	8-759-988-13	IC LM393PS	
IC501	8-759-011-65	IC MC74HC4053F		IC905	8-759-032-53	IC MC74HC244AF	
IC502	8-759-981-48	IC TL082M		IC906	8-759-059-50	IC MB88351PFV	
IC503	8-752-054-80	IC CXA1521M		IC907	8-759-059-50	IC MB88351PFV	
IC504	8-759-011-65	IC MC74HC4053F		IC908	8-759-064-36	IC MB88346BPFV	
IC506	8-759-981-48	IC TL082M		IC909	8-759-059-50	IC MB88351PFV	
IC507	8-759-082-61	IC TC4W53FU		IC910	8-759-064-36	IC MB88346BPFV	
IC508	8-759-082-61	IC TC4W53FU		IC911	8-759-059-50	IC MB88351PFV	
IC509	8-759-058-54	IC TC7S00FU(TE85R)		IC912	8-759-082-59	IC TC7W32FU	
IC510	8-759-011-65	IC MC74HC4053F		IC913	8-759-011-65	IC MC74HC4053F	
IC511	8-759-981-48	IC TL082M				< CHIP CONDUCTOR CHIP >	
IC512	8-752-054-80	IC CXA1521M					
IC513	8-759-011-65	IC MC74HC4053F		JR101	1-216-295-91	CONDUCTOR, CHIP (2012)	
IC514	8-759-981-48	IC TL082M		JR301	1-216-295-91	CONDUCTOR, CHIP (2012)	
IC515	8-759-700-95	IC NJM1496M		JR501	1-216-295-91	CONDUCTOR, CHIP (2012)	
IC516	8-759-011-63	IC MC74HC4051F		JR901	1-216-295-91	CONDUCTOR, CHIP (2012)	
IC517	8-759-011-65	IC MC74HC4053F		JR902	1-216-295-91	CONDUCTOR, CHIP (2012)	
IC518	8-759-981-48	IC TL082M		JR903	1-216-295-91	CONDUCTOR, CHIP (2012)	
IC519	8-759-073-90	IC TDA6111Q		JR904	1-216-295-91	CONDUCTOR, CHIP (2012)	
IC520	8-759-981-48	IC TL082M		JR905	1-216-295-91	CONDUCTOR, CHIP (2012)	
IC521	8-759-981-48	IC TL082M		JR906	1-216-295-91	CONDUCTOR, CHIP (2012)	
IC522	8-759-981-48	IC TL082M				< COIL >	
IC523	8-759-981-48	IC TL082M		L728	1-410-686-11	INDUCTOR 1mH	
IC524	8-759-011-65	IC MC74HC4053F		L900	1-412-002-31	INDUCTOR CHIP 4.7 $\mu$ H	
IC525	8-759-082-61	IC TC4W53FU					
IC526	8-759-011-65	IC MC74HC4053F					
IC527	8-759-981-48	IC TL082M					

REF NO.	PART NO.	DESCRIPTION	REMARK	REF NO.	PART NO.	DESCRIPTION	REMARK
		< TRANSISTOR >					
Q100	8-729-112-65	TRANSISTOR 2SA1462-Y33		Q379	8-729-107-31	TRANSISTOR 2SC3545-T43	
Q101	8-729-027-38	TRANSISTOR DTA144EKA-T146		Q380	8-729-920-59	TRANSISTOR IMX2	
Q102	8-729-107-31	TRANSISTOR 2SC3545-T43		Q381	8-729-920-59	TRANSISTOR IMX2	
Q103	8-729-112-65	TRANSISTOR 2SA1462-Y33		Q382	8-729-920-59	TRANSISTOR IMX2	
Q104	8-729-107-31	TRANSISTOR 2SC3545-T43		Q383	8-729-120-28	TRANSISTOR 2SC1623-L5L6	
Q105	8-729-107-31	TRANSISTOR 2SC3545-T43		Q384	8-729-107-31	TRANSISTOR 2SC3545-T43	
Q106	8-729-112-65	TRANSISTOR 2SA1462-Y33		Q385	8-729-112-65	TRANSISTOR 2SA1462-Y33	
Q107	8-729-107-31	TRANSISTOR 2SC3545-T43		Q386	8-729-107-31	TRANSISTOR 2SC3545-T43	
Q108	8-729-120-28	TRANSISTOR 2SC1623-L5L6		Q387	8-729-033-31	TRANSISTOR 2SK520K44K45-T1B	
Q140	8-729-107-31	TRANSISTOR 2SC3545-T43		Q388	8-729-033-31	TRANSISTOR 2SK520K44K45-T1B	
Q141	8-729-107-31	TRANSISTOR 2SC3545-T43		Q389	8-729-103-53	TRANSISTOR 2SC1654-N7	
Q142	8-729-107-31	TRANSISTOR 2SC3545-T43		Q390	8-729-027-59	TRANSISTOR DTC144EKA-T146	
Q143	8-729-112-65	TRANSISTOR 2SA1462-Y33		Q400	8-729-107-31	TRANSISTOR 2SC3545-T43	
Q144	8-729-112-65	TRANSISTOR 2SA1462-Y33		Q500	8-729-112-65	TRANSISTOR 2SA1462-Y33	
Q164	8-729-107-31	TRANSISTOR 2SC3545-T43		Q501	8-729-027-38	TRANSISTOR DTA144EKA-T146	
Q165	8-729-107-31	TRANSISTOR 2SC3545-T43		Q502	8-729-107-31	TRANSISTOR 2SC3545-T43	
Q166	8-729-120-28	TRANSISTOR 2SC1623-L5L6		Q503	8-729-112-65	TRANSISTOR 2SA1462-Y33	
Q167	8-729-107-31	TRANSISTOR 2SC3545-T43		Q504	8-729-107-31	TRANSISTOR 2SC3545-T43	
Q168	8-729-112-65	TRANSISTOR 2SA1462-Y33		Q505	8-729-107-31	TRANSISTOR 2SC3545-T43	
Q169	8-729-107-31	TRANSISTOR 2SC3545-T43		Q506	8-729-112-65	TRANSISTOR 2SA1462-Y33	
Q170	8-729-920-59	TRANSISTOR IMX2		Q507	8-729-107-31	TRANSISTOR 2SC3545-T43	
Q171	8-729-920-59	TRANSISTOR IMX2		Q510	8-729-107-31	TRANSISTOR 2SC3545-T43	
Q172	8-729-920-59	TRANSISTOR IMX2		Q540	8-729-107-31	TRANSISTOR 2SC3545-T43	
Q173	8-729-120-28	TRANSISTOR 2SC1623-L5L6		Q541	8-729-107-31	TRANSISTOR 2SC3545-T43	
Q174	8-729-107-31	TRANSISTOR 2SC3545-T43		Q542	8-729-107-31	TRANSISTOR 2SC3545-T43	
Q175	8-729-112-65	TRANSISTOR 2SA1462-Y33		Q543	8-729-112-65	TRANSISTOR 2SA1462-Y33	
Q176	8-729-107-31	TRANSISTOR 2SC3545-T43		Q544	8-729-112-65	TRANSISTOR 2SA1462-Y33	
Q177	8-729-033-31	TRANSISTOR 2SK520K44K45-T1B		Q567	8-729-107-31	TRANSISTOR 2SC3545-T43	
Q178	8-729-033-31	TRANSISTOR 2SK520K44K45-T1B		Q568	8-729-920-59	TRANSISTOR IMX2	
Q179	8-729-103-53	TRANSISTOR 2SC1654-N7		Q569	8-729-120-28	TRANSISTOR 2SC1623-L5L6	
Q190	8-729-027-59	TRANSISTOR DTC144EKA-T146		Q570	8-729-107-31	TRANSISTOR 2SC3545-T43	
Q200	8-729-107-31	TRANSISTOR 2SC3545-T43		Q571	8-729-112-65	TRANSISTOR 2SA1462-Y33	
Q300	8-729-112-65	TRANSISTOR 2SA1462-Y33		Q572	8-729-107-31	TRANSISTOR 2SC3545-T43	
Q301	8-729-027-38	TRANSISTOR DTA144EKA-T146		Q573	8-729-920-59	TRANSISTOR IMX2	
Q302	8-729-107-31	TRANSISTOR 2SC3545-T43		Q574	8-729-920-59	TRANSISTOR IMX2	
Q303	8-729-112-65	TRANSISTOR 2SA1462-Y33		Q575	8-729-920-59	TRANSISTOR IMX2	
Q304	8-729-107-31	TRANSISTOR 2SC3545-T43		Q576	8-729-120-28	TRANSISTOR 2SC1623-L5L6	
Q305	8-729-107-31	TRANSISTOR 2SC3545-T43		Q577	8-729-107-31	TRANSISTOR 2SC3545-T43	
Q306	8-729-107-31	TRANSISTOR 2SC3545-T43		Q578	8-729-112-65	TRANSISTOR 2SA1462-Y33	
Q307	8-729-112-65	TRANSISTOR 2SA1462-Y33		Q579	8-729-107-31	TRANSISTOR 2SC3545-T43	
Q308	8-729-120-28	TRANSISTOR 2SC1623-L5L6		Q580	8-729-033-31	TRANSISTOR 2SK520K44K45-T1B	
Q309	8-729-112-65	TRANSISTOR 2SA1462-Y33		Q581	8-729-033-31	TRANSISTOR 2SK520K44K45-T1B	
Q310	8-729-107-31	TRANSISTOR 2SC3545-T43		Q582	8-729-103-53	TRANSISTOR 2SC1654-N7	
Q350	8-729-107-31	TRANSISTOR 2SC3545-T43		Q590	8-729-027-59	TRANSISTOR DTC144EKA-T146	
Q351	8-729-107-31	TRANSISTOR 2SC3545-T43		Q600	8-729-107-31	TRANSISTOR 2SC3545-T43	
Q352	8-729-107-31	TRANSISTOR 2SC3545-T43		Q700	8-729-216-22	TRANSISTOR 2SA1162-G	
Q353	8-729-112-65	TRANSISTOR 2SA1462-Y33		Q701	8-729-216-22	TRANSISTOR 2SA1162-G	
Q354	8-729-112-65	TRANSISTOR 2SA1462-Y33		Q702	8-729-216-22	TRANSISTOR 2SA1162-G	
Q374	8-729-107-31	TRANSISTOR 2SC3545-T43		Q728	8-729-120-28	TRANSISTOR 2SC1623-L5L6	
Q375	8-729-107-31	TRANSISTOR 2SC3545-T43		Q729	8-729-120-28	TRANSISTOR 2SC1623-L5L6	
Q376	8-729-120-28	TRANSISTOR 2SC1623-L5L6		Q800	8-729-216-22	TRANSISTOR 2SA1162-G	
Q377	8-729-107-31	TRANSISTOR 2SC3545-T43		Q801	8-729-112-65	TRANSISTOR 2SA1462-Y33	
Q378	8-729-112-65	TRANSISTOR 2SA1462-Y33		Q802	8-729-216-22	TRANSISTOR 2SA1162-G	
				Q803	8-729-920-59	TRANSISTOR IMX2	



REF NO.	PART NO.	DESCRIPTION	REMARK	REF NO.	PART NO.	DESCRIPTION	REMARK
Q804	8-729-120-28	TRANSISTOR 2SC1623-L5L6		R116	1-208-784-11	METAL CHIP 1.2K	0.50% 1/10W
Q805	8-729-920-59	TRANSISTOR IMX2		R117	1-216-045-00	METAL GLAZE 680	5% 1/10W
Q806	8-729-216-22	TRANSISTOR 2SA1162-G		R118	1-216-009-00	METAL GLAZE 22	5% 1/10W
Q807	8-729-120-28	TRANSISTOR 2SC1623-L5L6		R119	1-216-073-00	METAL GLAZE 10K	5% 1/10W
Q808	8-729-120-28	TRANSISTOR 2SC1623-L5L6		R121	1-216-063-91	METAL GLAZE 3.9K	5% 1/10W
Q809	8-729-120-28	TRANSISTOR 2SC1623-L5L6		R122	1-216-049-91	METAL GLAZE 1K	5% 1/10W
Q810	8-729-925-42	TRANSISTOR IMT2		R123	1-216-049-91	METAL GLAZE 1K	5% 1/10W
Q811	8-729-925-42	TRANSISTOR IMT2		R124	1-216-025-91	METAL GLAZE 100	5% 1/10W
Q812	8-729-120-28	TRANSISTOR 2SC1623-L5L6		R140	1-216-638-11	METAL CHIP 300	0.50% 1/10W
Q813	8-729-216-22	TRANSISTOR 2SA1162-G		R141	1-216-674-11	METAL CHIP 9.1K	0.50% 1/10W
Q814	8-729-216-22	TRANSISTOR 2SA1162-G		R142	1-216-647-11	METAL CHIP 680	0.50% 1/10W
Q815	8-729-120-28	TRANSISTOR 2SC1623-L5L6		R143	1-216-047-91	METAL GLAZE 820	5% 1/10W
Q816	8-729-216-22	TRANSISTOR 2SA1162-G		R144	1-216-647-11	METAL CHIP 680	0.50% 1/10W
Q817	8-729-120-28	TRANSISTOR 2SC1623-L5L6		R147	1-216-063-91	METAL GLAZE 3.9K	5% 1/10W
Q818	8-729-120-28	TRANSISTOR 2SC1623-L5L6		R148	1-218-764-11	METAL CHIP 330K	0.50% 1/10W
Q819	8-729-120-28	TRANSISTOR 2SC1623-L5L6		R149	1-216-025-91	METAL GLAZE 100	5% 1/10W
Q820	8-729-216-22	TRANSISTOR 2SA1162-G		R150	1-218-760-11	METAL CHIP 220K	0.50% 1/10W
Q821	8-729-027-59	TRANSISTOR DTC144EKA-T146		R151	1-208-806-11	METAL CHIP 10K	0.50% 1/10W
Q822	8-729-120-28	TRANSISTOR 2SC1623-L5L6		R152	1-208-854-11	METAL CHIP 1M	0.50% 1/10W
Q823	8-729-120-28	TRANSISTOR 2SC1623-L5L6		R153	1-216-671-11	METAL CHIP 6.8K	0.50% 1/10W
Q824	8-729-216-22	TRANSISTOR 2SA1162-G		R155	1-216-650-11	METAL CHIP 910	0.50% 1/10W
Q825	8-729-216-22	TRANSISTOR 2SA1162-G		R156	1-216-651-11	METAL CHIP 1K	0.50% 1/10W
Q826	8-729-202-38	TRANSISTOR 2SC3326N-A		R157	1-216-677-11	METAL CHIP 12K	0.50% 1/10W
Q827	8-729-202-38	TRANSISTOR 2SC3326N-A		R158	1-208-824-11	METAL CHIP 56K	0.50% 1/10W
Q900	8-729-027-59	TRANSISTOR DTC144EKA-T146		R159	1-208-784-11	METAL CHIP 1.2K	0.50% 1/10W
Q901	8-729-027-59	TRANSISTOR DTC144EKA-T146		R160	1-216-025-91	METAL GLAZE 100	5% 1/10W
Q902	8-729-027-38	TRANSISTOR DTA144EKA-T146		R162	1-216-049-91	METAL GLAZE 1K	5% 1/10W
		< RESISTOR >		R163	1-216-073-00	METAL GLAZE 10K	5% 1/10W
R10	1-216-025-91	METAL GLAZE 100	5% 1/10W	R164	1-216-633-11	METAL CHIP 180	0.50% 1/10W
R11	1-216-025-91	METAL GLAZE 100	5% 1/10W	R165	1-216-627-11	METAL CHIP 100	0.50% 1/10W
R12	1-216-025-91	METAL GLAZE 100	5% 1/10W	R166	1-216-057-00	METAL GLAZE 2.2K	5% 1/10W
R13	1-216-025-91	METAL GLAZE 100	5% 1/10W	R167	1-216-057-00	METAL GLAZE 2.2K	5% 1/10W
R14	1-216-025-91	METAL GLAZE 100	5% 1/10W	R168	1-216-049-91	METAL GLAZE 1K	5% 1/10W
R15	1-216-025-91	METAL GLAZE 100	5% 1/10W	R169	1-216-053-00	METAL GLAZE 1.5K	5% 1/10W
R16	1-216-025-91	METAL GLAZE 100	5% 1/10W	R170	1-208-785-11	METAL CHIP 1.3K	0.50% 1/10W
R17	1-216-025-91	METAL GLAZE 100	5% 1/10W	R171	1-208-810-11	METAL CHIP 15K	0.50% 1/10W
R20	1-249-400-11	CARBON 39	5% 1/4W	R172	1-216-049-91	METAL GLAZE 1K	5% 1/10W
R100	1-216-085-00	METAL GLAZE 33K	5% 1/10W	R173	1-216-025-91	METAL GLAZE 100	5% 1/10W
R101	1-216-119-00	METAL GLAZE 820K	5% 1/10W	R174	1-216-033-00	METAL GLAZE 220	5% 1/10W
R102	1-216-049-91	METAL GLAZE 1K	5% 1/10W	R175	1-216-065-00	METAL GLAZE 4.7K	5% 1/10W
R103	1-216-097-91	METAL GLAZE 100K	5% 1/10W	R176	1-216-073-00	METAL GLAZE 10K	5% 1/10W
R104	1-216-025-91	METAL GLAZE 100	5% 1/10W	R177	1-208-789-11	METAL CHIP 2K	0.50% 1/10W
R105	1-216-057-00	METAL GLAZE 2.2K	5% 1/10W	R178	1-216-662-11	METAL CHIP 3K	0.50% 1/10W
R106	1-216-025-91	METAL GLAZE 100	5% 1/10W	R179	1-216-025-91	METAL GLAZE 100	5% 1/10W
R107	1-216-049-91	METAL GLAZE 1K	5% 1/10W	R180	1-216-657-11	METAL CHIP 1.8K	0.50% 1/10W
R108	1-216-049-91	METAL GLAZE 1K	5% 1/10W	R181	1-208-784-11	METAL CHIP 1.2K	0.50% 1/10W
R109	1-216-009-00	METAL GLAZE 22	5% 1/10W	R182	1-208-800-11	METAL CHIP 5.6K	0.50% 1/10W
R110	1-216-009-00	METAL GLAZE 22	5% 1/10W	R183	1-216-025-91	METAL GLAZE 100	5% 1/10W
R111	1-216-657-11	METAL CHIP 1.8K	0.50% 1/10W	R184	1-216-051-00	METAL GLAZE 1.2K	5% 1/10W
R112	1-216-663-11	METAL CHIP 3.3K	0.50% 1/10W	R185	1-208-806-11	METAL CHIP 10K	0.50% 1/10W
R113	1-216-025-91	METAL GLAZE 100	5% 1/10W	R186	1-208-806-11	METAL CHIP 10K	0.50% 1/10W
R114	1-216-651-11	METAL CHIP 1K	0.50% 1/10W	R187	1-216-671-11	METAL CHIP 6.8K	0.50% 1/10W
R115	1-216-033-00	METAL GLAZE 220	5% 1/10W	R188	1-216-049-91	METAL GLAZE 1K	5% 1/10W
				R189	1-216-025-91	METAL GLAZE 100	5% 1/10W
				R190	1-208-806-11	METAL CHIP 10K	0.50% 1/10W

**BK**

REF NO.	PART NO.	DESCRIPTION	REMARK	REF NO.	PART NO.	DESCRIPTION	REMARK
R191	1-216-665-11	METAL CHIP	3.9K 0.50% 1/10W	R252	1-216-689-11	METAL GLAZE	39K 5% 1/10W
R192	1-216-687-11	METAL CHIP	33K 0.50% 1/10W	R253	1-216-093-00	METAL GLAZE	68K 5% 1/10W
R193	1-208-810-11	METAL CHIP	15K 0.50% 1/10W	R254	1-216-055-00	METAL GLAZE	1.8K 5% 1/10W
R194	1-216-025-91	METAL GLAZE	100 5% 1/10W	R255	1-216-073-00	METAL GLAZE	10K 5% 1/10W
R195	1-208-784-11	METAL CHIP	1.2K 0.50% 1/10W	R256	1-216-073-00	METAL GLAZE	10K 5% 1/10W
R196	1-216-025-91	METAL GLAZE	100 5% 1/10W	R257	1-202-549-00	SOLID	100 20% 1/2W
R197	1-216-665-11	METAL CHIP	3.9K 0.50% 1/10W	R258	1-216-699-11	METAL CHIP	100K 0.50% 1/10W
R198	1-208-789-11	METAL CHIP	2K 0.50% 1/10W	R259	1-216-073-00	METAL GLAZE	10K 5% 1/10W
R199	1-216-661-11	METAL CHIP	2.7K 0.50% 1/10W	R272	1-216-025-91	METAL GLAZE	100 5% 1/10W
R201	1-208-806-11	METAL CHIP	10K 0.50% 1/10W	R273	1-216-073-00	METAL GLAZE	10K 5% 1/10W
R202	1-216-677-11	METAL CHIP	12K 0.50% 1/10W	R287	1-216-033-00	METAL GLAZE	220 5% 1/10W
R203	1-216-665-11	METAL CHIP	3.9K 0.50% 1/10W	R288	1-216-033-00	METAL GLAZE	220 5% 1/10W
R204	1-208-801-11	METAL CHIP	6.2K 0.50% 1/10W	R300	1-216-085-00	METAL GLAZE	33K 5% 1/10W
R205	1-216-025-91	METAL GLAZE	100 5% 1/10W	R301	1-216-119-00	METAL GLAZE	820K 5% 1/10W
R206	1-208-810-11	METAL CHIP	15K 0.50% 1/10W	R302	1-216-049-91	METAL GLAZE	1K 5% 1/10W
R207	1-216-649-11	METAL CHIP	820 0.50% 1/10W	R303	1-216-097-91	METAL GLAZE	100K 5% 1/10W
R208	1-216-647-11	METAL CHIP	680 0.50% 1/10W	R305	1-216-057-00	METAL GLAZE	2.2K 5% 1/10W
R210	1-216-647-11	METAL CHIP	680 0.50% 1/10W	R306	1-216-025-91	METAL GLAZE	100 5% 1/10W
R211	1-216-025-91	METAL GLAZE	100 5% 1/10W	R307	1-216-049-91	METAL GLAZE	1K 5% 1/10W
R212	1-216-025-91	METAL GLAZE	100 5% 1/10W	R308	1-216-049-91	METAL GLAZE	1K 5% 1/10W
R213	1-216-667-11	METAL CHIP	4.7K 0.50% 1/10W	R309	1-216-009-00	METAL GLAZE	22 5% 1/10W
R214	1-216-659-11	METAL CHIP	2.2K 0.50% 1/10W	R310	1-216-009-00	METAL GLAZE	22 5% 1/10W
R215	1-216-657-11	METAL CHIP	1.8K 0.50% 1/10W	R311	1-216-697-91	METAL CHIP	82K 0.50% 1/10W
R216	1-216-673-11	METAL CHIP	8.2K 0.50% 1/10W	R312	1-216-657-11	METAL CHIP	1.8K 0.50% 1/10W
R217	1-216-073-00	METAL GLAZE	10K 5% 1/10W	R313	1-216-663-11	METAL CHIP	3.3K 0.50% 1/10W
R218	1-216-025-91	METAL GLAZE	100 5% 1/10W	R314	1-216-009-00	METAL CHIP	22 5% 1/10W
R219	1-216-033-00	METAL GLAZE	220 5% 1/10W	R315	1-216-676-11	METAL CHIP	11K 0.50% 1/10W
R220	1-216-659-11	METAL CHIP	2.2K 0.50% 1/10W	R316	1-216-697-91	METAL CHIP	82K 0.50% 1/10W
R221	1-208-800-11	METAL CHIP	5.6K 0.50% 1/10W	R317	1-216-651-11	METAL CHIP	1K 0.50% 1/10W
R222	1-216-025-91	METAL GLAZE	100 5% 1/10W	R318	1-216-033-00	METAL GLAZE	220 5% 1/10W
R223	1-208-784-11	METAL CHIP	1.2K 0.50% 1/10W	R319	1-208-784-11	METAL CHIP	1.2K 0.50% 1/10W
R224	1-208-806-11	METAL CHIP	10K 0.50% 1/10W	R320	1-216-045-00	METAL GLAZE	680 5% 1/10W
R225	1-216-659-11	METAL CHIP	2.2K 0.50% 1/10W	R321	1-216-009-00	METAL GLAZE	22 5% 1/10W
R226	1-216-655-11	METAL CHIP	1.5K 0.50% 1/10W	R322	1-216-073-00	METAL GLAZE	10K 5% 1/10W
R227	1-208-784-11	METAL CHIP	1.2K 0.50% 1/10W	R324	1-216-025-91	METAL GLAZE	100 5% 1/10W
R228	1-216-025-91	METAL GLAZE	100 5% 1/10W	R327	1-216-025-91	METAL GLAZE	100 5% 1/10W
R229	1-216-659-11	METAL CHIP	2.2K 0.50% 1/10W	R328	1-216-073-00	METAL GLAZE	10K 5% 1/10W
R230	1-208-806-11	METAL CHIP	10K 0.50% 1/10W	R329	1-216-687-11	METAL CHIP	33K 0.50% 1/10W
R232	1-216-073-00	METAL GLAZE	10K 5% 1/10W	R330	1-216-687-11	METAL CHIP	33K 0.50% 1/10W
R236	1-216-697-91	METAL CHIP	82K 0.50% 1/10W	R331	1-216-695-11	METAL CHIP	68K 0.50% 1/10W
R237	1-216-667-11	METAL CHIP	4.7K 0.50% 1/10W	R332	1-216-667-11	METAL CHIP	4.7K 0.50% 1/10W
R238	1-216-073-00	METAL GLAZE	10K 5% 1/10W	R333	1-208-789-11	METAL CHIP	2K 0.50% 1/10W
R239	1-216-671-11	METAL CHIP	6.8K 0.50% 1/10W	R334	1-216-687-11	METAL CHIP	33K 0.50% 1/10W
R240	1-208-800-11	METAL CHIP	5.6K 0.50% 1/10W	R335	1-216-695-11	METAL CHIP	68K 0.50% 1/10W
R241	1-216-651-11	METAL CHIP	1K 0.50% 1/10W	R336	1-216-687-11	METAL CHIP	33K 0.50% 1/10W
R242	1-216-073-00	METAL GLAZE	10K 5% 1/10W	R337	1-216-661-11	METAL CHIP	2.7K 0.50% 1/10W
R243	1-208-803-11	METAL CHIP	7.5K 0.50% 1/10W	R338	1-216-650-11	METAL CHIP	910 0.50% 1/10W
R244	1-216-111-91	METAL GLAZE	390K 5% 1/10W	R340	1-216-651-11	METAL CHIP	1K 0.50% 1/10W
R245	1-216-033-00	METAL GLAZE	220 5% 1/10W	R342	1-216-663-11	METAL CHIP	3.3K 0.50% 1/10W
R246	1-208-800-11	METAL CHIP	5.6K 0.50% 1/10W	R343	1-216-025-91	METAL GLAZE	100 5% 1/10W
R247	1-208-801-11	METAL CHIP	6.2K 0.50% 1/10W	R344	1-216-063-00	METAL GLAZE	3.9K 5% 1/10W
R248	1-214-903-31	METAL	39K 1% 1/2W	R345	1-216-049-91	METAL GLAZE	1K 5% 1/10W
R249	1-208-800-11	METAL CHIP	5.6K 0.50% 1/10W	R346	1-208-806-11	METAL CHIP	10K 0.50% 1/10W
R250	1-216-033-00	METAL GLAZE	220 5% 1/10W	R350	1-216-638-11	METAL CHIP	300 0.50% 1/10W
R251	1-216-695-11	METAL CHIP	68K 0.50% 1/10W	R351	1-216-674-11	METAL CHIP	9.1K 0.50% 1/10W

REF NO.	PART NO.	DESCRIPTION	REMARK	REF NO.	PART NO.	DESCRIPTION	REMARK				
R352	1-216-647-11	METAL CHIP	680	0.50%	1/10W	R413	1-216-665-11	METAL CHIP	3.9K	0.50%	1/10W
R353	1-216-047-91	METAL GLAZE	820	5%	1/10W	R414	1-208-801-11	METAL CHIP	6.2K	0.50%	1/10W
R354	1-216-647-11	METAL CHIP	680	0.50%	1/10W	R415	1-216-025-91	METAL GLAZE	100	5%	1/10W
R357	1-216-063-91	METAL GLAZE	3.9K	5%	1/10W	R416	1-208-810-11	METAL CHIP	15K	0.50%	1/10W
R358	1-218-764-11	METAL CHIP	330K	0.50%	1/10W	R417	1-216-649-11	METAL CHIP	820	0.50%	1/10W
R359	1-216-025-91	METAL GLAZE	100	5%	1/10W	R418	1-216-647-11	METAL CHIP	680	0.50%	1/10W
R360	1-218-760-11	METAL CHIP	220K	0.50%	1/10W	R420	1-216-647-11	METAL CHIP	680	0.50%	1/10W
R361	1-208-806-11	METAL CHIP	10K	0.50%	1/10W	R421	1-216-025-91	METAL GLAZE	100	5%	1/10W
R362	1-208-854-11	METAL CHIP	1M	0.50%	1/10W	R422	1-216-025-91	METAL GLAZE	100	5%	1/10W
R363	1-216-671-11	METAL CHIP	6.8K	0.50%	1/10W	R423	1-216-667-11	METAL CHIP	4.7K	0.50%	1/10W
R365	1-216-650-11	METAL CHIP	910	0.50%	1/10W	R424	1-216-659-11	METAL CHIP	2.2K	0.50%	1/10W
R366	1-216-651-11	METAL CHIP	1K	0.50%	1/10W	R425	1-216-657-11	METAL CHIP	1.8K	0.50%	1/10W
R367	1-216-677-11	METAL CHIP	12K	0.50%	1/10W	R426	1-216-673-11	METAL CHIP	8.2K	0.50%	1/10W
R368	1-208-824-11	METAL CHIP	56K	0.50%	1/10W	R427	1-216-073-00	METAL GLAZE	10K	5%	1/10W
R369	1-208-784-11	METAL CHIP	1.2K	0.50%	1/10W	R428	1-216-025-91	METAL GLAZE	100	5%	1/10W
R370	1-216-025-91	METAL GLAZE	100	5%	1/10W	R429	1-216-033-00	METAL GLAZE	220	5%	1/10W
R372	1-216-049-91	METAL GLAZE	1K	5%	1/10W	R430	1-216-659-11	METAL CHIP	2.2K	0.50%	1/10W
R373	1-216-073-00	METAL GLAZE	10K	5%	1/10W	R431	1-208-800-11	METAL CHIP	5.6K	0.50%	1/10W
R374	1-216-633-11	METAL CHIP	180	0.50%	1/10W	R432	1-216-025-91	METAL GLAZE	100	5%	1/10W
R375	1-216-627-11	METAL CHIP	100	0.50%	1/10W	R433	1-208-784-11	METAL CHIP	1.2K	0.50%	1/10W
R376	1-216-057-00	METAL GLAZE	2.2K	5%	1/10W	R434	1-208-806-11	METAL CHIP	10K	0.50%	1/10W
R377	1-216-057-00	METAL GLAZE	2.2K	5%	1/10W	R435	1-216-659-11	METAL CHIP	2.2K	0.50%	1/10W
R378	1-216-049-91	METAL GLAZE	1K	5%	1/10W	R436	1-216-655-11	METAL CHIP	1.5K	0.50%	1/10W
R379	1-216-053-00	METAL GLAZE	1.5K	5%	1/10W	R437	1-208-784-11	METAL CHIP	1.2K	0.50%	1/10W
R380	1-216-049-91	METAL GLAZE	1K	5%	1/10W	R438	1-216-025-91	METAL GLAZE	100	5%	1/10W
R381	1-216-025-91	METAL GLAZE	100	5%	1/10W	R439	1-216-659-11	METAL CHIP	2.2K	0.50%	1/10W
R383	1-216-065-11	METAL GLAZE	4.7K	5%	1/10W	R440	1-208-806-11	METAL CHIP	10K	0.50%	1/10W
R384	1-216-073-00	METAL GLAZE	10K	5%	1/10W	R442	1-216-073-00	METAL GLAZE	10K	5%	1/10W
R385	1-208-789-11	METAL CHIP	2K	0.50%	1/10W	R446	1-216-697-91	METAL CHIP	82K	0.50%	1/10W
R386	1-208-814-11	METAL CHIP	22K	0.50%	1/10W	R447	1-216-667-11	METAL CHIP	4.7K	0.50%	1/10W
R387	1-216-687-11	METAL CHIP	33K	0.50%	1/10W	R448	1-216-073-00	METAL GLAZE	10K	5%	1/10W
R388	1-216-662-11	METAL CHIP	3K	0.50%	1/10W	R449	1-216-671-11	METAL CHIP	6.8K	0.50%	1/10W
R389	1-216-025-91	METAL GLAZE	100	5%	1/10W	R450	1-208-800-11	METAL CHIP	5.6K	0.50%	1/10W
R390	1-216-657-11	METAL CHIP	1.8K	0.50%	1/10W	R451	1-216-651-11	METAL CHIP	1K	0.50%	1/10W
R391	1-208-784-11	METAL CHIP	1.2K	0.50%	1/10W	R452	1-216-073-00	METAL GLAZE	10K	5%	1/10W
R392	1-208-800-11	METAL CHIP	5.6K	0.50%	1/10W	R453	1-208-803-11	METAL CHIP	7.5K	0.50%	1/10W
R393	1-216-025-91	METAL GLAZE	100	5%	1/10W	R454	1-216-111-91	METAL GLAZE	390K	5%	1/10W
R394	1-216-051-00	METAL GLAZE	1.2K	5%	1/10W	R455	1-216-033-00	METAL GLAZE	220	5%	1/10W
R395	1-208-806-11	METAL CHIP	10K	0.50%	1/10W	R456	1-208-800-11	METAL CHIP	5.6K	0.50%	1/10W
R396	1-208-806-11	METAL CHIP	10K	0.50%	1/10W	R457	1-208-801-11	METAL CHIP	6.2K	0.50%	1/10W
R397	1-216-671-11	METAL CHIP	6.8K	0.50%	1/10W	R458	1-214-903-31	METAL	39K	1%	1/2W
R398	1-216-049-91	METAL GLAZE	1K	5%	1/10W	R459	1-208-800-11	METAL CHIP	5.6K	0.50%	1/10W
R399	1-216-025-91	METAL GLAZE	100	5%	1/10W	R460	1-216-033-00	METAL GLAZE	220	5%	1/10W
R400	1-208-806-11	METAL CHIP	10K	0.50%	1/10W	R461	1-216-695-11	METAL CHIP	68K	0.50%	1/10W
R401	1-216-665-11	METAL CHIP	3.9K	0.50%	1/10W	R462	1-216-689-11	METAL GLAZE	39K	5%	1/10W
R402	1-216-687-11	METAL CHIP	33K	0.50%	1/10W	R463	1-216-093-00	METAL GLAZE	68K	5%	1/10W
R403	1-208-810-11	METAL CHIP	15K	0.50%	1/10W	R464	1-216-055-00	METAL GLAZE	1.8K	5%	1/10W
R404	1-216-025-91	METAL GLAZE	100	5%	1/10W	R465	1-216-073-00	METAL GLAZE	10K	5%	1/10W
R405	1-208-784-11	METAL CHIP	1.2K	0.50%	1/10W	R466	1-216-073-00	METAL GLAZE	10K	5%	1/10W
R406	1-216-025-91	METAL GLAZE	100	5%	1/10W	R467	1-202-549-00	SOLID	100	20%	1/2W
R407	1-216-665-11	METAL CHIP	3.9K	0.50%	1/10W	R468	1-216-699-11	METAL CHIP	100K	0.50%	1/10W
R408	1-208-789-11	METAL CHIP	2K	0.50%	1/10W	R469	1-216-073-00	METAL GLAZE	10K	5%	1/10W
R409	1-216-661-11	METAL CHIP	2.7K	0.50%	1/10W	R472	1-216-025-91	METAL GLAZE	100	5%	1/10W
R411	1-208-806-11	METAL CHIP	10K	0.50%	1/10W	R473	1-216-073-00	METAL GLAZE	10K	5%	1/10W
R412	1-216-677-11	METAL CHIP	12K	0.50%	1/10W	R474	1-216-033-00	METAL GLAZE	220	5%	1/10W

**BK**

REF NO.	PART NO.	DESCRIPTION	REMARK	REF NO.	PART NO.	DESCRIPTION	REMARK
R480	1-218-764-11	METAL CHIP	330K	0.50%	1/10W		
R481	1-208-854-11	METAL CHIP	1M	0.50%	1/10W		
R482	1-208-800-11	METAL CHIP	5.6K	0.50%	1/10W		
R483	1-216-049-91	METAL GLAZE	1K	5%	1/10W		
R485	1-216-073-00	METAL GLAZE	10K	5%	1/10W		
R486	1-216-057-00	METAL GLAZE	2.2K	5%	1/10W		
R487	1-216-033-00	METAL GLAZE	220	5%	1/10W		
R488	1-216-033-00	METAL GLAZE	220	5%	1/10W		
R500	1-216-085-00	METAL GLAZE	33K	5%	1/10W		
R501	1-216-119-00	METAL GLAZE	820K	5%	1/10W		
R502	1-216-049-91	METAL GLAZE	1K	5%	1/10W		
R503	1-216-097-91	METAL GLAZE	100K	5%	1/10W		
R505	1-216-057-00	METAL GLAZE	2.2K	5%	1/10W		
R506	1-216-025-91	METAL GLAZE	100	5%	1/10W		
R507	1-216-049-91	METAL GLAZE	1K	5%	1/10W		
R508	1-216-049-91	METAL GLAZE	1K	5%	1/10W		
R509	1-216-009-00	METAL GLAZE	22	5%	1/10W		
R510	1-216-009-00	METAL GLAZE	22	5%	1/10W		
R511	1-216-697-91	METAL CHIP	82K	0.50%	1/10W		
R512	1-216-657-11	METAL CHIP	1.8K	0.50%	1/10W		
R513	1-216-663-11	METAL CHIP	3.3K	0.50%	1/10W		
R514	1-216-009-00	METAL GLAZE	22	5%	1/10W		
R515	1-216-674-11	METAL CHIP	9.1K	0.50%	1/10W		
R516	1-216-697-91	METAL CHIP	82K	0.50%	1/10W		
R517	1-216-651-11	METAL CHIP	1K	0.50%	1/10W		
R518	1-216-033-00	METAL GLAZE	220	5%	1/10W		
R519	1-208-784-11	METAL CHIP	1.2K	0.50%	1/10W		
R520	1-216-045-00	METAL GLAZE	680	5%	1/10W		
R521	1-216-009-00	METAL GLAZE	22	5%	1/10W		
R522	1-216-073-00	METAL GLAZE	10K	5%	1/10W		
R524	1-216-025-91	METAL GLAZE	100	5%	1/10W		
R527	1-208-810-11	METAL CHIP	15K	0.50%	1/10W		
R528	1-216-690-11	METAL CHIP	43K	0.50%	1/10W		
R529	1-216-025-91	METAL GLAZE	100	5%	1/10W		
R530	1-216-073-00	METAL GLAZE	10K	5%	1/10W		
R531	1-216-063-91	METAL GLAZE	3.9K	5%	1/10W		
R532	1-216-049-91	METAL GLAZE	1K	5%	1/10W		
R540	1-216-637-11	METAL CHIP	270	0.50%	1/10W		
R541	1-216-674-11	METAL CHIP	9.1K	0.50%	1/10W		
R542	1-216-647-11	METAL CHIP	680	0.50%	1/10W		
R543	1-216-047-91	METAL GLAZE	820	5%	1/10W		
R544	1-216-647-11	METAL CHIP	680	0.50%	1/10W		
R547	1-216-063-91	METAL GLAZE	3.9K	5%	1/10W		
R548	1-218-764-11	METAL CHIP	330K	0.50%	1/10W		
R549	1-216-025-91	METAL GLAZE	100	5%	1/10W		
R550	1-218-760-11	METAL CHIP	220K	0.50%	1/10W		
R551	1-208-806-11	METAL CHIP	10K	0.50%	1/10W		
R552	1-208-854-11	METAL CHIP	1M	0.50%	1/10W		
R553	1-216-671-11	METAL CHIP	6.8K	0.50%	1/10W		
R555	1-216-650-11	METAL CHIP	910	0.50%	1/10W		
R556	1-216-651-11	METAL CHIP	1K	0.50%	1/10W		
R557	1-216-677-11	METAL CHIP	12K	0.50%	1/10W		
R558	1-208-824-11	METAL CHIP	56K	0.50%	1/10W		
R559	1-208-784-11	METAL CHIP	1.2K	0.50%	1/10W		
R560	1-216-025-91	METAL GLAZE	100	5%	1/10W		
R562	1-216-049-91	METAL GLAZE	1K	5%	1/10W		
R563	1-216-049-91	METAL GLAZE	1K	5%	1/10W		
R564	1-216-025-91	METAL GLAZE	100	5%	1/10W		
R565	1-216-073-00	METAL GLAZE	10K	5%	1/10W		
R566	1-216-097-91	METAL GLAZE	100K	5%	1/10W		
R567	1-216-097-91	METAL GLAZE	100K	5%	1/10W		
R568	1-216-633-11	METAL CHIP	180	0.50%	1/10W		
R569	1-216-627-11	METAL CHIP	100	0.50%	1/10W		
R570	1-216-057-00	METAL GLAZE	2.2K	5%	1/10W		
R571	1-216-057-00	METAL GLAZE	2.2K	5%	1/10W		
R572	1-216-049-91	METAL GLAZE	1K	5%	1/10W		
R573	1-216-053-00	METAL GLAZE	1.5K	5%	1/10W		
R574	1-216-049-91	METAL GLAZE	1K	5%	1/10W		
R575	1-216-025-91	METAL GLAZE	100	5%	1/10W		
R576	1-216-057-00	METAL GLAZE	2.2K	5%	1/10W		
R577	1-216-065-11	METAL GLAZE	4.7K	5%	1/10W		
R578	1-216-073-00	METAL GLAZE	10K	5%	1/10W		
R579	1-208-789-11	METAL CHIP	2K	0.50%	1/10W		
R580	1-208-814-11	METAL CHIP	22K	0.50%	1/10W		
R581	1-216-687-11	METAL CHIP	33K	0.50%	1/10W		
R582	1-216-662-11	METAL CHIP	3K	0.50%	1/10W		
R583	1-216-025-91	METAL GLAZE	100	5%	1/10W		
R584	1-216-657-11	METAL CHIP	1.8K	0.50%	1/10W		
R585	1-208-784-11	METAL CHIP	1.2K	0.50%	1/10W		
R586	1-208-800-11	METAL CHIP	5.6K	0.50%	1/10W		
R587	1-216-025-91	METAL GLAZE	100	5%	1/10W		
R588	1-216-051-00	METAL GLAZE	1.2K	5%	1/10W		
R589	1-208-806-11	METAL CHIP	10K	0.50%	1/10W		
R590	1-208-806-11	METAL CHIP	10K	0.50%	1/10W		
R591	1-216-671-11	METAL CHIP	6.8K	0.50%	1/10W		
R592	1-216-049-91	METAL GLAZE	1K	5%	1/10W		
R593	1-216-025-91	METAL GLAZE	100	5%	1/10W		
R594	1-208-806-11	METAL CHIP	10K	0.50%	1/10W		
R595	1-216-665-11	METAL CHIP	3.9K	0.50%	1/10W		
R596	1-216-687-11	METAL CHIP	33K	0.50%	1/10W		
R597	1-208-810-11	METAL CHIP	15K	0.50%	1/10W		
R598	1-216-025-91	METAL GLAZE	100	5%	1/10W		
R599	1-208-784-11	METAL CHIP	1.2K	0.50%	1/10W		
R600	1-216-025-91	METAL GLAZE	100	5%	1/10W		
R601	1-216-665-11	METAL CHIP	3.9K	0.50%	1/10W		
R602	1-208-789-11	METAL CHIP	2K	0.50%	1/10W		
R603	1-216-661-11	METAL CHIP	2.7K	0.50%	1/10W		
R605	1-208-806-11	METAL CHIP	10K	0.50%	1/10W		
R606	1-216-677-11	METAL CHIP	12K	0.50%	1/10W		
R607	1-216-665-11	METAL CHIP	3.9K	0.50%	1/10W		
R608	1-208-801-11	METAL CHIP	6.2K	0.50%	1/10W		
R609	1-216-025-91	METAL GLAZE	100	5%	1/10W		
R610	1-208-810-11	METAL CHIP	15K	0.50%	1/10W		
R611	1-216-649-11	METAL CHIP	820	0.50%	1/10W		
R612	1-216-647-11	METAL CHIP	680	0.50%	1/10W		
R614	1-216-647-11	METAL CHIP	680	0.50%	1/10W		
R615	1-216-025-91	METAL GLAZE	100	5%	1/10W		
R616	1-216-025-91	METAL GLAZE	100	5%	1/10W		
R617	1-216-667-11	METAL CHIP	4.7K	0.50%	1/10W		
R618	1-216-659-11	METAL CHIP	2.2K	0.50%	1/10W		





REF NO.	PART NO.	DESCRIPTION	REMARK	REF NO.	PART NO.	DESCRIPTION	REMARK
R619	1-216-657-11	METAL CHIP	1.8K 0.50% 1/10W	R703	1-208-806-11	METAL CHIP	10K 0.50% 1/10W
R620	1-216-673-11	METAL CHIP	8.2K 0.50% 1/10W	R704	1-208-806-11	METAL CHIP	10K 0.50% 1/10W
R621	1-216-073-00	METAL GLAZE	10K 5% 1/10W	R705	1-208-806-11	METAL CHIP	10K 0.50% 1/10W
R622	1-216-025-91	METAL GLAZE	100 5% 1/10W	R706	1-208-806-11	METAL CHIP	10K 0.50% 1/10W
R623	1-216-033-00	METAL GLAZE	220 5% 1/10W	R707	1-208-806-11	METAL CHIP	10K 0.50% 1/10W
R624	1-216-659-11	METAL CHIP	2.2K 0.50% 1/10W	R708	1-208-806-11	METAL CHIP	10K 0.50% 1/10W
R625	1-208-800-11	METAL CHIP	5.6K 0.50% 1/10W	R709	1-216-677-11	METAL CHIP	12K 0.50% 1/10W
R626	1-216-025-91	METAL GLAZE	100 5% 1/10W	R710	1-216-671-11	METAL CHIP	6.8K 0.50% 1/10W
R627	1-208-784-11	METAL CHIP	1.2K 0.50% 1/10W	R711	1-216-677-11	METAL CHIP	12K 0.50% 1/10W
R628	1-208-806-11	METAL CHIP	10K 0.50% 1/10W	R712	1-216-671-11	METAL CHIP	6.8K 0.50% 1/10W
R629	1-216-659-11	METAL CHIP	2.2K 0.50% 1/10W	R713	1-216-049-91	METAL GLAZE	1K 5% 1/10W
R630	1-216-655-11	METAL CHIP	1.5K 0.50% 1/10W	R714	1-216-049-91	METAL GLAZE	1K 5% 1/10W
R631	1-208-784-11	METAL CHIP	1.2K 0.50% 1/10W	R715	1-216-067-00	METAL GLAZE	5.6K 5% 1/10W
R632	1-216-025-91	METAL GLAZE	100 5% 1/10W	R716	1-216-049-91	METAL GLAZE	1K 5% 1/10W
R633	1-216-659-11	METAL CHIP	2.2K 0.50% 1/10W	R717	1-216-097-91	METAL GLAZE	100K 5% 1/10W
R634	1-208-806-11	METAL CHIP	10K 0.50% 1/10W	R718	1-216-677-11	METAL CHIP	12K 0.50% 1/10W
R636	1-216-073-00	METAL GLAZE	10K 5% 1/10W	R719	1-216-671-11	METAL CHIP	6.8K 0.50% 1/10W
R640	1-216-697-91	METAL CHIP	82K 0.50% 1/10W	R720	1-216-049-91	METAL GLAZE	1K 5% 1/10W
R641	1-216-667-11	METAL CHIP	4.7K 0.50% 1/10W	R721	1-216-657-11	METAL CHIP	1.8K 0.50% 1/10W
R642	1-216-073-00	METAL GLAZE	10K 5% 1/10W	R723	1-216-049-91	METAL GLAZE	1K 5% 1/10W
R643	1-216-671-11	METAL CHIP	6.8K 0.50% 1/10W	R724	1-216-657-11	METAL CHIP	1.8K 0.50% 1/10W
R644	1-208-800-11	METAL CHIP	5.6K 0.50% 1/10W	R725	1-214-903-31	METAL	39K 1% 1/2W
R645	1-216-651-11	METAL CHIP	1K 0.50% 1/10W	R726	1-216-121-91	METAL GLAZE	1M 5% 1/10W
R646	1-216-073-00	METAL GLAZE	10K 5% 1/10W	R727	1-202-549-00	SOLID	100 20% 1/2W
R647	1-208-803-11	METAL CHIP	7.5K 0.50% 1/10W	R728	1-216-025-91	METAL GLAZE	100 5% 1/10W
R648	1-216-111-91	METAL GLAZE	390K 5% 1/10W	R729	1-216-065-00	METAL GLAZE	4.7K 5% 1/10W
R649	1-216-033-00	METAL GLAZE	220 5% 1/10W	R730	1-216-651-11	METAL CHIP	1K 0.50% 1/10W
R650	1-208-800-11	METAL CHIP	5.6K 0.50% 1/10W	R731	1-216-699-11	METAL CHIP	100K 0.50% 1/10W
R651	1-208-801-11	METAL CHIP	6.2K 0.50% 1/10W	R732	1-216-049-91	METAL GLAZE	1K 5% 1/10W
R652	1-214-903-31	METAL	39K 1% 1/2W	R733	1-216-295-91	CONDUCTOR, CHIP (2012)	
R653	1-208-800-11	METAL CHIP	5.6K 0.50% 1/10W	R734	1-216-671-11	METAL CHIP	6.8K 0.50% 1/10W
R654	1-216-033-00	METAL GLAZE	220 5% 1/10W	R735	1-216-033-00	METAL GLAZE	220 5% 1/10W
R655	1-216-695-11	METAL CHIP	68K 0.50% 1/10W	R736	1-216-033-00	METAL GLAZE	220 5% 1/10W
R656	1-216-689-11	METAL GLAZE	39K 5% 1/10W	R800	1-216-025-91	METAL GLAZE	100 5% 1/10W
R657	1-216-093-00	METAL GLAZE	68K 5% 1/10W	R801	1-216-063-91	METAL GLAZE	3.9K 5% 1/10W
R658	1-216-055-00	METAL GLAZE	1.8K 5% 1/10W	R802	1-216-085-00	METAL GLAZE	33K 5% 1/10W
R659	1-216-073-00	METAL GLAZE	10K 5% 1/10W	R803	1-216-049-91	METAL GLAZE	1K 5% 1/10W
R660	1-216-073-00	METAL GLAZE	10K 5% 1/10W	R804	1-216-063-91	METAL GLAZE	3.9K 5% 1/10W
R661	1-202-549-00	SOLID	100 20% 1/2W	R805	1-216-091-00	METAL GLAZE	56K 5% 1/10W
R662	1-216-699-11	METAL CHIP	100K 0.50% 1/10W	R806	1-216-049-91	METAL GLAZE	1K 5% 1/10W
R663	1-216-073-00	METAL GLAZE	10K 5% 1/10W	R807	1-216-079-00	METAL GLAZE	18K 5% 1/10W
R672	1-216-025-91	METAL GLAZE	100 5% 1/10W	R808	1-216-049-91	METAL GLAZE	1K 5% 1/10W
R673	1-216-073-00	METAL GLAZE	10K 5% 1/10W	R809	1-216-049-91	METAL GLAZE	1K 5% 1/10W
R674	1-216-033-00	METAL GLAZE	220 5% 1/10W	R810	1-216-045-00	METAL GLAZE	680 5% 1/10W
R680	1-218-764-11	METAL CHIP	330K 0.50% 1/10W	R811	1-216-049-91	METAL GLAZE	1K 5% 1/10W
R681	1-208-854-11	METAL CHIP	1M 0.50% 1/10W	R812	1-216-063-91	METAL GLAZE	3.9K 5% 1/10W
R682	1-208-800-11	METAL CHIP	5.6K 0.50% 1/10W	R813	1-216-053-00	METAL GLAZE	1.5K 5% 1/10W
R683	1-216-049-91	METAL GLAZE	1K 5% 1/10W	R814	1-216-065-00	METAL GLAZE	4.7K 5% 1/10W
R685	1-216-073-00	METAL GLAZE	10K 5% 1/10W	R815	1-216-077-00	METAL GLAZE	15K 5% 1/10W
R686	1-216-057-00	METAL GLAZE	2.2K 5% 1/10W	R816	1-216-085-00	METAL GLAZE	33K 5% 1/10W
R687	1-216-033-00	METAL GLAZE	220 5% 1/10W	R817	1-216-097-91	METAL GLAZE	100K 5% 1/10W
R688	1-216-033-00	METAL GLAZE	220 5% 1/10W	R818	1-216-081-00	METAL GLAZE	22K 5% 1/10W
R700	1-208-806-11	METAL CHIP	10K 0.50% 1/10W	R819	1-216-085-00	METAL GLAZE	33K 5% 1/10W
R701	1-208-806-11	METAL CHIP	10K 0.50% 1/10W	R820	1-216-053-00	METAL GLAZE	1.5K 5% 1/10W
R702	1-208-806-11	METAL CHIP	10K 0.50% 1/10W	R821	1-216-049-91	METAL GLAZE	1K 5% 1/10W

**BK**

REF NO.	PART NO.	DESCRIPTION	REMARK	REF NO.	PART NO.	DESCRIPTION	REMARK
R822	1-216-081-00	METAL GLAZE	22K 5% 1/10W	R900	1-216-025-91	METAL GLAZE	100 5% 1/10W
R823	1-216-037-00	METAL GLAZE	330 5% 1/10W	R901	1-216-097-91	METAL GLAZE	100K 5% 1/10W
R824	1-216-041-00	METAL GLAZE	470 5% 1/10W	R902	1-216-097-91	METAL GLAZE	100K 5% 1/10W
R825	1-216-057-00	METAL GLAZE	2.2K 5% 1/10W	R903	1-216-097-91	METAL GLAZE	100K 5% 1/10W
R826	1-216-694-11	METAL CHIP	62K 0.50% 1/10W	R904	1-216-025-91	METAL GLAZE	100 5% 1/10W
R827	1-216-057-00	METAL GLAZE	2.2K 5% 1/10W	R905	1-216-025-91	METAL GLAZE	100 5% 1/10W
R828	1-216-037-00	METAL GLAZE	330 5% 1/10W	R906	1-216-025-91	METAL GLAZE	100 5% 1/10W
R829	1-218-766-11	METAL CHIP	390K 0.50% 1/10W	R907	1-216-097-91	METAL GLAZE	100K 5% 1/10W
R830	1-218-755-11	METAL CHIP	130K 0.50% 1/10W	R908	1-216-121-91	METAL GLAZE	1M 5% 1/10W
R831	1-216-661-11	METAL CHIP	2.7K 0.50% 1/10W	R909	1-216-097-91	METAL GLAZE	100K 5% 1/10W
R832	1-216-637-11	METAL CHIP	270 0.50% 1/10W	R910	1-216-097-91	METAL GLAZE	100K 5% 1/10W
R833	1-216-637-11	METAL CHIP	270 0.50% 1/10W	R911	1-216-097-91	METAL GLAZE	100K 5% 1/10W
R834	1-216-659-11	METAL CHIP	2.2K 0.50% 1/10W	R912	1-216-677-11	METAL CHIP	12K 0.50% 1/10W
R835	1-216-069-00	METAL GLAZE	6.8K 5% 1/10W	R913	1-208-812-11	METAL CHIP	18K 0.50% 1/10W
R836	1-216-051-00	METAL GLAZE	1.2K 5% 1/10W	R914	1-216-065-00	METAL GLAZE	4.7K 5% 1/10W
R837	1-216-081-00	METAL GLAZE	22K 5% 1/10W	R915	1-216-097-91	METAL GLAZE	100K 5% 1/10W
R838	1-216-067-00	METAL GLAZE	5.6K 5% 1/10W	R916	1-216-097-91	METAL GLAZE	100K 5% 1/10W
R839	1-216-676-11	METAL CHIP	11K 0.50% 1/10W	R917	1-216-097-91	METAL GLAZE	100K 5% 1/10W
R840	1-216-079-00	METAL GLAZE	18K 5% 1/10W	R918	1-216-097-91	METAL GLAZE	100K 5% 1/10W
R841	1-216-097-91	METAL GLAZE	100K 5% 1/10W	R919	1-216-661-11	METAL CHIP	2.7K 0.50% 1/10W
R842	1-216-695-11	METAL CHIP	68K 0.50% 1/10W	R920	1-216-097-91	METAL GLAZE	100K 5% 1/10W
R843	1-216-057-00	METAL GLAZE	2.2K 5% 1/10W	R921	1-216-667-11	METAL CHIP	4.7K 0.50% 1/10W
R844	1-216-059-00	METAL GLAZE	2.7K 5% 1/10W	R922	1-216-671-11	METAL CHIP	6.8K 0.50% 1/10W
R845	1-216-697-91	METAL CHIP	82K 0.50% 1/10W	R923	1-216-097-91	METAL GLAZE	100K 5% 1/10W
R846	1-208-810-11	METAL CHIP	15K 0.50% 1/10W	R924	1-216-097-91	METAL GLAZE	100K 5% 1/10W
R847	1-216-073-00	METAL GLAZE	10K 5% 1/10W	R925	1-216-097-91	METAL GLAZE	100K 5% 1/10W
R848	1-216-095-00	METAL GLAZE	82K 5% 1/10W	R926	1-216-097-91	METAL GLAZE	100K 5% 1/10W
R849	1-216-037-00	METAL GLAZE	330 5% 1/10W	R927	1-216-097-91	METAL GLAZE	100K 5% 1/10W
R850	1-216-699-11	METAL CHIP	100K 0.50% 1/10W	R928	1-216-097-91	METAL GLAZE	100K 5% 1/10W
R851	1-216-085-00	METAL GLAZE	33K 5% 1/10W	R929	1-208-806-11	METAL CHIP	10K 0.50% 1/10W
R852	1-216-094-00	METAL GLAZE	75K 5% 1/10W	R930	1-208-806-11	METAL CHIP	10K 0.50% 1/10W
R853	1-216-049-91	METAL GLAZE	1K 5% 1/10W	R931	1-216-097-91	METAL GLAZE	100K 5% 1/10W
R854	1-208-806-11	METAL CHIP	10K 0.50% 1/10W	R932	1-216-073-00	METAL GLAZE	10K 5% 1/10W
R855	1-216-649-11	METAL CHIP	820 0.50% 1/10W	R933	1-216-097-91	METAL GLAZE	100K 5% 1/10W
R856	1-216-064-00	METAL GLAZE	4.3K 5% 1/10W	R934	1-216-097-91	METAL GLAZE	100K 5% 1/10W
R857	1-216-064-00	METAL GLAZE	4.3K 5% 1/10W	R935	1-216-097-91	METAL GLAZE	100K 5% 1/10W
R858	1-216-699-11	METAL CHIP	100K 0.50% 1/10W	R936	1-216-097-91	METAL GLAZE	100K 5% 1/10W
R859	1-216-065-00	METAL GLAZE	4.7K 5% 1/10W	R937	1-216-097-91	METAL GLAZE	100K 5% 1/10W
R860	1-216-065-00	METAL GLAZE	4.7K 5% 1/10W	R938	1-216-097-91	METAL GLAZE	100K 5% 1/10W
R861	1-216-667-11	METAL CHIP	4.7K 0.50% 1/10W	R939	1-216-097-91	METAL GLAZE	100K 5% 1/10W
R862	1-216-699-11	METAL CHIP	100K 0.50% 1/10W	R940	1-216-097-91	METAL GLAZE	100K 5% 1/10W
R863	1-216-674-11	METAL CHIP	9.1K 0.50% 1/10W	R947	1-216-073-00	METAL GLAZE	10K 5% 1/10W
R864	1-208-806-11	METAL CHIP	10K 0.50% 1/10W	R948	1-216-073-00	METAL GLAZE	10K 5% 1/10W
R865	1-216-649-11	METAL CHIP	820 0.50% 1/10W	R949	1-216-073-00	METAL GLAZE	10K 5% 1/10W
R866	1-216-057-00	METAL GLAZE	2.2K 5% 1/10W	R950	1-216-073-00	METAL GLAZE	10K 5% 1/10W
R867	1-216-025-91	METAL GLAZE	100 5% 1/10W	R951	1-216-073-00	METAL GLAZE	10K 5% 1/10W
R868	1-216-049-11	METAL GLAZE	1K 5% 1/10W	R952	1-216-073-00	METAL GLAZE	10K 5% 1/10W
R869	1-216-059-00	METAL GLAZE	2.7K 5% 1/10W	R953	1-216-073-00	METAL GLAZE	10K 5% 1/10W
R870	1-216-667-11	METAL CHIP	4.7K 0.50% 1/10W	R955	1-216-073-00	METAL GLAZE	10K 5% 1/10W
R871	1-216-089-91	METAL GLAZE	47K 5% 1/10W	R956	1-216-073-00	METAL GLAZE	10K 5% 1/10W
R872	1-216-073-00	METAL GLAZE	10K 5% 1/10W	R957	1-216-073-00	METAL GLAZE	10K 5% 1/10W
R873	1-216-089-91	METAL GLAZE	47K 5% 1/10W	R960	1-216-049-91	METAL GLAZE	1K 5% 1/10W
R874	1-216-073-00	METAL GLAZE	10K 5% 1/10W	R970	1-216-073-00	METAL GLAZE	10K 5% 1/10W
R875	1-216-067-00	METAL GLAZE	5.6K 5% 1/10W	R980	1-216-065-00	METAL GLAZE	4.7K 5% 1/10W
R876	1-216-061-00	METAL GLAZE	3.3K 5% 1/10W				

The components identified by shading and marked  $\Delta$  are critical for safety.  
Replace only with the part number specified.

Les composants identifiés par une trame et une marque  $\Delta$  sont critiques pour la sécurité.  
Ne les remplacer que par une pièce portant le numéro spécifié.



REF NO.	PART NO.	DESCRIPTION	REMARK	REF NO.	PART NO.	DESCRIPTION	REMARK
		< TERMINAL BOARD >					
TB1	1-537-959-11	TERMINAL BOARD ASSY, I/O		*A-1195-104-B		COMPLETE PCB, PA (20E1E/20E1U)	*****
		< THERMISTOR >					
TH300	1-807-796-11	THERMISTOR		*A-1195-111-A		COMPLETE PCB, PA (14E1E/14E1U/14E5E/14E5U)	*****
		< CRYSTAL >				< CAPACITOR >	
X900	1-578-689-21	VIBRATOR		C101	1-126-934-11	ELECT	220 $\mu$ F 20% 16V
*****				C102	1-123-024-21	ELECT	33 $\mu$ F 160V
*A-1190-229-A		MOUNTED PCB, PC (20E1E/20E1U/20F1E/20F1U)	*****	C103	1-106-359-00	MYLAR	0.0047 $\mu$ F 10% 200V
*A-1190-238-A		MOUNTED PCB, PC (14E1E/14E1U/14E5E/14E5U/14F1E/14F1U/14F5E/14F5U)	*****	C104	1-136-111-00	FILM	1 $\mu$ F 5% 200V
		< CAPACITOR >		C105	1-106-355-12	MYLAR	0.0033 $\mu$ F 10% 200V
C1	1-106-367-00	MYLAR	0.01 $\mu$ F 10% 100V	C106	1-164-004-11	CERAMIC CHIP	0.1 $\mu$ F 10% 25V
C2	1-106-367-00	MYLAR	0.01 $\mu$ F 10% 100V	C107	1-162-134-11	CERAMIC	470pF 10% 2KV
		< CONNECTOR >		C108	1-136-080-00	FILM	0.011 $\mu$ F 3% 2KV
CN1	*1-573-986-11	PIN, CONNECTOR (PC BOARD) 5P		C109	1-107-912-11	ELECT	330 $\mu$ F 20% 50V
CN2	*1-564-514-11	PLUG, CONNECTOR 11P		C110	1-107-912-11	ELECT	330 $\mu$ F 20% 50V
CN3	*1-508-766-00	PIN, CONNECTOR (5MM PITCH) 4P		C201	1-126-934-11	ELECT	220 $\mu$ F 20% 16V
		< RESISTOR >		C202	1-164-232-11	CERAMIC CHIP	0.01 $\mu$ F 10% 50V
R1	1-215-437-00	METAL	4.7K 1% 1/4W	C203	1-162-114-00	CERAMIC	0.0047 $\mu$ F 2KV
R2	1-215-437-00	METAL	4.7K 1% 1/4W	C301	1-163-038-91	CERAMIC CHIP	0.1 $\mu$ F 25V
R3	1-215-428-00	METAL	2K 1% 1/4W	C302	1-164-505-11	CERAMIC CHIP	2.2 $\mu$ F 16V
		(14E1E/14E1U/14E5E/14E5U/14F1E/14F1U/14F5E/14F5U)		C303	1-163-093-00	CERAMIC CHIP	10pF 5% 50V
R3	1-215-426-00	METAL	1.6K 1% 1/4W	C304	1-164-505-11	CERAMIC CHIP	2.2 $\mu$ F 16V
		(20E1E/20E1U/20F1E/20F1U)		C305	1-164-505-11	CERAMIC CHIP	2.2 $\mu$ F 16V
R4	1-215-437-00	METAL	4.7K 1% 1/4W	C501	1-124-242-00	ELECT	33 $\mu$ F 20% 25V
R5	1-215-437-00	METAL	4.7K 1% 1/4W	C502	1-163-117-00	CERAMIC CHIP	100pF 5% 50V
R6	1-215-427-00	METAL	1.8K 1% 1/4W	C503	1-126-160-11	ELECT	1 $\mu$ F 20% 50V
		(14E1E/14E1U/14E5E/14E5U/14F1E/14F1U/14F5E/14F5U)		C504	1-164-161-11	CERAMIC CHIP	0.0022 $\mu$ F 10% 50V
R6	1-215-425-00	METAL	1.5K 1% 1/4W	C505	1-124-234-00	ELECT	22 $\mu$ F 20% 16V
		(20E1E/20E1U/20F1E/20F1U)		C506	1-163-009-11	CERAMIC CHIP	0.001 $\mu$ F 10% 50V
R7	1-216-393-00	METAL OXIDE	2.2 5% 3W F	C507	1-164-004-11	CERAMIC CHIP	0.1 $\mu$ F 10% 25V
		(20E1E/20E1U/20F1E/20F1U)		C508	1-163-125-00	CERAMIC CHIP	220pF 5% 50V
R7	1-216-389-11	METAL OXIDE	1 5% 3W F	C509	1-126-157-11	ELECT	10 $\mu$ F 20% 16V
		(14E1E/14E1U/14E5E/14E5U/14F1E/14F1U/14F5E/14F5U)		C510	1-124-242-00	ELECT	33 $\mu$ F 20% 25V
		< TRANSFORMER >		C511	1-164-346-11	CERAMIC CHIP	1 $\mu$ F 16V
T1 $\Delta$	X-4033-491-1	FBT ASSY, NX-4201/J1F4		C512	1-164-232-11	CERAMIC CHIP	0.01 $\mu$ F 10% 50V
		(14E1E/14E1U/14E5E/14E5U/14F1E/14F1U/14F5E/14F5U)		C513	1-164-346-11	CERAMIC CHIP	1 $\mu$ F 16V
T1 $\Delta$	X-4033-492-1	FBT ASSY, NX-4201/J1E4		C514	1-164-346-11	CERAMIC CHIP	1 $\mu$ F 16V
		(20E1E/20E1U/20F1E/20F1U)		C515	1-164-232-11	CERAMIC CHIP	0.01 $\mu$ F 10% 50V
*****				C516	1-164-346-11	CERAMIC CHIP	1 $\mu$ F 16V
*A-1195-097-A		COMPLETE PCB, PA (20F1E/20F1U)	*****	C517	1-126-964-11	ELECT	10 $\mu$ F 20% 50V
*A-1195-098-B		COMPLETE PCB, PA (14F1E/14F1U/14F5E/14F5U)	*****	C518	1-107-701-11	ELECT	47 $\mu$ F 20% 16V
				C521	1-164-346-11	CERAMIC CHIP	1 $\mu$ F 16V
				C522	1-126-163-11	ELECT	4.7 $\mu$ F 20% 16V
				C801	1-126-160-11	ELECT	1 $\mu$ F 20% 50V
				C802	1-130-481-00	MYLAR	0.0068 $\mu$ F 5% 50V
				C811	1-164-004-11	CERAMIC CHIP	0.1 $\mu$ F 10% 25V
				C901	1-128-526-11	ELECT	100 $\mu$ F 20% 25V
				C902	1-128-526-11	ELECT	100 $\mu$ F 20% 25V
				C903	1-164-232-11	CERAMIC CHIP	0.01 $\mu$ F 10% 50V
				C904	1-164-232-11	CERAMIC CHIP	0.01 $\mu$ F 10% 50V
				C907	1-107-639-11	ELECT	47 $\mu$ F 20% 160V
				C911	1-104-664-11	ELECT	47 $\mu$ F 20% 25V
				C912	1-164-004-11	CERAMIC CHIP	0.1 $\mu$ F 10% 25V



Les composants identifiés par une trame et une marque  $\Delta$  sont critiques pour la sécurité.  
Ne les remplacer que par une pièce portant le numéro spécifié.

The components identified by shading and marked  $\Delta$  are critical for safety.  
Replace only with the part number specified.

REF NO.	PART NO.	DESCRIPTION	REMARK	REF NO.	PART NO.	DESCRIPTION	REMARK
C921	1-128-526-11	ELECT	100 $\mu$ F 20% 25V	JR900	1-216-295-91	CONDUCTOR, CHIP (2012)	
C923	1-164-232-11	CERAMIC CHIP	0.01 $\mu$ F 10% 50V			(14E1E/14E1U/14E5E/14E5U/20E1E/20E1U)	
		< CONNECTOR >				< COIL >	
CN901	1-774-536-11	CONNECTOR PIN (PC BOARD) 34P		L101	1-429-284-11	TRANSFORMER, FERRITE (LOT)	
CN902	1-766-243-11	PIN, CONNECTOR (PC BOARD) 5P		L102	1-406-659-11	COIL, CHOKE 10 $\mu$ H	
CN903	1-766-241-11	PIN, CONNECTOR (PC BOARD) 3P				< TRANSISTOR >	
CN904	*1-564-514-11	PLUG, CONNECTOR 11P		Q101	8-729-019-57	TRANSISTOR 2SA1208S-TP	
CN905	1-766-240-11	PIN, CONNECTOR (PC BOARD) 2P		Q102	8-729-015-28	TRANSISTOR IRFI9630GS	
CN906	*1-564-507-11	PLUG, CONNECTOR 4P			4-382-854-11	SCREW (M3X10), P, SW (+) (Q102)	
		< DIODE >		Q103	8-729-216-22	TRANSISTOR 2SA1162-G	
D101	8-719-404-46	DIODE MA110		Q104	8-729-120-28	TRANSISTOR 2SC1623-L5L6	
D102	8-719-106-71	DIODE RD12M-B2				< RESISTOR >	
D103	8-719-920-67	DIODE ERC91-02		Q105	8-729-266-82	TRANSISTOR 2SC2668-O	
D104	8-719-404-46	DIODE MA110		Q107	8-729-120-28	TRANSISTOR 2SC1623-L5L6	
D105	8-719-939-07	DIODE ERD38-06		Q108	8-729-216-22	TRANSISTOR 2SA1162-G	
D106	8-719-939-07	DIODE ERD38-06		Q109	8-729-020-64	TRANSISTOR IRFPG50LF	
D107	8-719-941-74	DIODE ERB91-02			4-047-285-01	SHEET, INSULATING (Q109)	
D201	8-719-901-19	DIODE V11N			4-382-854-11	SCREW (M3X10), P, SW (+) (Q109)	
D203	8-719-404-46	DIODE MA110		Q111	8-729-120-28	TRANSISTOR 2SC1623-L5L6	
D204	8-719-404-46	DIODE MA110		Q112	8-729-216-22	TRANSISTOR 2SA1162-G	
D205	8-719-404-46	DIODE MA110		Q113	8-729-027-59	TRANSISTOR DTC144EKA-T146	
D301	8-719-404-46	DIODE MA110		Q201	8-729-020-07	TRANSISTOR 2SC4686A(LBSONY)	
D321	8-719-404-46	DIODE MA110		Q202	8-729-020-07	TRANSISTOR 2SC4686A(LBSONY)	
D322	8-719-404-46	DIODE MA110		Q301	8-729-216-22	TRANSISTOR 2SA1162-G	
D401	8-719-404-46	DIODE MA110		Q302	8-729-216-22	TRANSISTOR 2SA1162-G	
D501	8-719-404-46	DIODE MA110		Q303	8-729-120-28	TRANSISTOR 2SC1623-L5L6	
D502	8-719-404-46	DIODE MA110		Q304	8-729-140-96	TRANSISTOR 2SD774-34	
D505	8-719-404-46	DIODE MA110		Q305	8-729-140-97	TRANSISTOR 2SB734-34	
D511	8-719-404-46	DIODE MA110		Q321	8-729-020-07	TRANSISTOR 2SC4686A(LBSONY)	
D512	8-719-404-46	DIODE MA110		Q322	8-729-020-07	TRANSISTOR 2SC4686A(LBSONY)	
D513	8-719-105-38	DIODE RD3.0M-B1		Q401	8-729-020-07	TRANSISTOR 2SC4686A(LBSONY)	
D514	8-719-404-46	DIODE MA110				< RESISTOR >	
D516	8-719-404-46	DIODE MA110		R101	1-216-347-11	METAL OXIDE 0.68 5% 1W F	
D517	8-719-105-38	DIODE RD3.0M-B1		R102	1-216-635-11	METAL CHIP 220 0.50% 1/10W	
D518	8-719-404-46	DIODE MA110		R103	1-218-762-11	METAL CHIP 270K 0.50% 1/10W	
D519	8-719-404-46	DIODE MA110		R104	1-216-105-91	METAL GLAZE 220K 5% 1/10W	
D521	8-719-404-46	DIODE MA110		R105	1-216-055-00	METAL GLAZE 1.8K 5% 1/10W	
D801	8-719-106-71	DIODE RD12M-B2		R106	1-216-635-11	METAL CHIP 220 0.50% 1/10W	
D802	8-719-404-46	DIODE MA110		R107	1-218-762-11	METAL CHIP 270K 0.50% 1/10W	
<b>D901 <math>\Delta</math></b>	<b>8-759-300-59</b>	<b>DIODE HZT33-02TA</b>		R108	1-216-073-00	METAL GLAZE 10K 5% 1/10W	
<b>D902 <math>\Delta</math></b>	<b>8-759-300-59</b>	<b>DIODE HZT33-02TA</b>		R109	1-216-081-00	METAL GLAZE 22K 5% 1/10W	
		< IC >		R110	1-249-397-11	CARBON 22 5% 1/4W F	
IC401	8-759-983-69	IC LM358PS		R111	1-215-911-11	METAL OXIDE 100 5% 3W F	
IC501	8-759-346-56	IC FA5301N-TE1		R112	1-216-065-00	METAL GLAZE 4.7K 5% 1/10W	
IC502	8-759-988-13	IC LM393PS		R113	1-216-065-00	METAL GLAZE 4.7K 5% 1/10W	
IC801	8-759-981-48	IC TL082M		R114	1-216-073-00	METAL GLAZE 10K 5% 1/10W	
IC901	8-759-231-58	IC TA7812S		R115	1-216-065-00	METAL GLAZE 4.7K 5% 1/10W	
		< CHIP CONDUCTOR >		R116	1-216-073-00	METAL GLAZE 10K 5% 1/10W	
JR100	1-216-295-91	CONDUCTOR, CHIP (2012)	(14F1E/14F1U/14F5E/14F5U/20F1E/20F1U)	R117	1-216-001-00	METAL GLAZE 10 5% 1/10W	
				R118	1-216-349-00	METAL OXIDE 1 5% 1W F	
				R119	1-216-349-00	METAL OXIDE 1 5% 1W F	
				R201	1-216-089-91	METAL GLAZE 47K 5% 1/10W	

• The components identified by **■** in this manual have been carefully factory-selected for each set in order to satisfy regulations regarding X-ray radiation. Should replacement be required, replace only with the value originally used.

Les composants identifiés par une trame et une marque **■** sont critiques pour la sécurité. Ne les remplacer que par une pièce portant le numéro spécifié.

The components identified by shading and marked **△** are critical for safety. Replace only with the part number specified.



REF NO.	PART NO.	DESCRIPTION	REMARK	REF NO.	PART NO.	DESCRIPTION	REMARK
R202	1-216-083-00	METAL GLAZE 27K	5% 1/10W	R519	1-216-081-00	METAL GLAZE 22K	5% 1/10W
R203	1-216-101-00	METAL GLAZE 150K	5% 1/10W	R524	1-208-823-11	METAL CHIP 51K	0.50% 1/10W
R204	1-216-065-00	METAL GLAZE 4.7K	5% 1/10W	R525	1-208-814-11	METAL CHIP 22K	0.50% 1/10W
R205	1-216-073-00	METAL GLAZE 10K	5% 1/10W	R526	1-216-694-11	METAL CHIP 62K	0.50% 1/10W
R206	1-216-073-00	METAL GLAZE 10K	5% 1/10W	R527	1-208-812-11	METAL CHIP 18K	0.50% 1/10W
R207	1-208-612-11	METAL OXIDE 10M	5% 1W			(14E1E/14E1U/14E5E/14E5U/14F1E/14F1U/14F5E/14F5U)	
R208	1-208-612-11	METAL OXIDE 10M	5% 1W	R527	1-208-814-11	METAL CHIP 22K	0.50% 1/10W
R209	1-216-097-91	METAL GLAZE 100K	5% 1/10W			(20E1E/20E1U/20F1E/20F1U)	
R211	1-202-719-00	SOLID 1M	20% 1/2W	R529	1-216-081-00	METAL GLAZE 22K	5% 1/10W
<b>■</b> R212 <b>△</b>	1-212-998-00	FUSIBLE 470	5% 1/2W F	R530	1-208-822-11	METAL CHIP 47K	0.50% 1/10W
R301	1-216-025-91	METAL GLAZE 100	5% 1/10W	R532	1-208-823-11	METAL CHIP 51K	0.50% 1/10W
R302	1-216-053-00	METAL GLAZE 1.5K	5% 1/10W	R801	1-216-097-91	METAL GLAZE 100K	5% 1/10W
R303	1-216-069-00	METAL GLAZE 6.8K	5% 1/10W	R802	1-208-806-11	METAL CHIP 10K	0.50% 1/10W
R304	1-216-051-00	METAL GLAZE 1.2K	5% 1/10W			(20E1E/20E1U/20F1E/20F1U)	
R305	1-216-053-00	METAL GLAZE 1.5K	5% 1/10W	R802	1-216-671-11	METAL CHIP 6.8K	0.50% 1/10W
R306	1-216-097-91	METAL GLAZE 100K	5% 1/10W			(14E1E/14E1U/14E5E/14E5U/14F1E/14F1U/14F5E/14F5U)	
R307	1-208-610-11	METAL OXIDE 2M	5% 1W	R804	1-208-814-11	METAL CHIP 22K	0.50% 1/10W
R308	1-216-035-00	METAL GLAZE 270	5% 1/10W	R808	1-216-049-91	METAL GLAZE 1K	5% 1/10W
R309	1-216-069-00	METAL GLAZE 6.8K	5% 1/10W	R811	1-216-097-91	METAL GLAZE 100K	5% 1/10W
R310	1-249-397-11	CARBON 22	5% 1/4W F	R812	1-216-025-91	METAL GLAZE 100K	5% 1/10W
R311	1-249-397-11	CARBON 22	5% 1/4W F	R813	1-216-025-91	METAL GLAZE 100K	5% 1/10W
R312	1-249-401-11	CARBON 47	5% 1/4W F	R901	1-215-902-11	METAL OXIDE 47K	5% 2W F
R321	1-216-093-00	METAL GLAZE 68K	5% 1/10W	R902	1-215-902-11	METAL OXIDE 47K	5% 2W F
R322	1-208-610-11	METAL OXIDE 2M	5% 1W			< VARIABLE RESISTOR >	
R323	1-208-612-11	METAL OXIDE 10M	5% 1W	<b>■</b> RV501 <b>△</b>	1-228-991-11	RES, ADJ, METAL GLAZE 22K	
R324	1-202-830-00	SOLID 10K	20% 1/2W		3-710-578-01	COVER, VOLUME, 6 MOLD (RV501)	
R401	1-216-073-00	METAL GLAZE 10K	5% 1/10W	<b>■</b> RV502 <b>△</b>	1-228-996-11	RES, ADJ, METAL GLAZE 47K	
R402	1-216-089-91	METAL GLAZE 47K	5% 1/10W		3-710-578-01	COVER, VOLUME, 6 MOLD (RV502)	
R403	1-216-073-00	METAL GLAZE 10K	5% 1/10W	<b>■</b> RV503 <b>△</b>	1-228-993-11	RES, ADJ, METAL GLAZE 4.7K	
R404	1-216-073-00	METAL GLAZE 10K	5% 1/10W			(14E1E/14E1U/14E5E/14E5U/14F1E/14F1U/14F5E/14F5U)	
R405	1-216-103-91	METAL GLAZE 180K	5% 1/10W	<b>■</b> RV503 <b>△</b>	1-228-994-11	RES, ADJ, METAL GLAZE 10K	
R406	1-202-719-00	SOLID 1M	20% 1/2W			(20E1E/20E1U/20F1E/20F1U)	
R501	1-216-045-00	METAL GLAZE 680	5% 1/10W		3-710-578-01	COVER, VOLUME, 6 MOLD (RV503)	
R502	1-216-073-00	METAL GLAZE 10K	5% 1/10W			< TRANSFORMER >	
R503	1-216-073-00	METAL GLAZE 10K	5% 1/10W	T301	1-424-555-11	TRANSFORMER, FERRITE (DFT)	
R504	1-216-685-11	METAL CHIP 27K	0.50% 1/10W			*****	
R505	1-216-083-00	METAL GLAZE 27K	5% 1/10W		*A-1316-258-A	COMPLETE PCB, G (include GA, GB, GC mounted)	
R506	1-216-069-00	METAL GLAZE 6.8K	5% 1/10W			*****	
R507	1-216-073-00	METAL GLAZE 10K	5% 1/10W		*X-4033-116-1	FRAME ASSY, POWER	
R508	1-216-073-00	METAL GLAZE 10K	5% 1/10W	<b>△</b> 1-251-263-11		INLET AC	
R509	1-216-667-11	METAL GLAZE 4.7K	0.50% 1/10W		1-900-214-49	CONNECTOR ASSY, VH 7P	
R510	1-216-667-11	METAL GLAZE 4.7K	0.50% 1/10W		1-900-214-50	CONNECTOR ASSY, FASTEN TAB	
R511	1-216-093-00	METAL GLAZE 68K	5% 1/10W		2-990-241-02	HOLDER(A), PLUG	
R512	1-216-073-00	METAL GLAZE 10K	5% 1/10W		3-648-057-00	NUT (ISO-4), U	
R513	1-216-677-11	METAL CHIP 12K	0.50% 1/10W		3-648-057-00	NUT (ISO-4), U	
R514	1-218-754-11	METAL CHIP 120K	0.50% 1/10W		*4-050-794-01	INSULATOR	
R515	1-218-769-11	METAL CHIP 510K	0.50% 1/10W		*4-050-795-01	SPACER, REAR PANEL	
R516	1-218-770-11	METAL CHIP 560K	0.50% 1/10W		*4-050-798-01	PLATE, NUT, AC INLET	
		(14E1E/14E1U/14E5E/14E5U/14F1E/14F1U/14F5E/14F5U)			*4-050-801-01	PLATE (LARGE), NUT	
R516	1-218-768-11	METAL CHIP 470K	0.50% 1/10W		*4-050-814-01	SHIELD, PCB	
		(20E1E/20E1U/20F1E/20F1U)					
R517	1-216-697-91	METAL CHIP 82K	0.50% 1/10W				
		(14E1E/14E1U/14E5E/14E5U/14F1E/14F1U/14F5E/14F5U)					
R517	1-216-696-11	METAL CHIP 75K	0.50% 1/10W				
		(20E1E/20E1U/20F1E/20F1U)					

Les composants identifiés par une trame et une marque  $\Delta$  sont critiques pour la sécurité.  
Ne les remplacer que par une pièce portant le numéro spécifié.

The components identified by shading and marked  $\Delta$  are critical for safety.  
Replace only with the part number specified.

G

REF NO.	PART NO.	DESCRIPTION	REMARK	REF NO.	PART NO.	DESCRIPTION	REMARK
	*4-050-818-01	PANEL, POWER UNIT		C37	1-129-898-00	FILM	0.0022 $\mu$ F 5% 630V
	*4-050-824-01	INSULATOR, POWER UNIT		C38	1-136-165-00	FILM	0.1 $\mu$ F 5% 50V
	*4-050-850-01	COVER, POWER UNIT		C40	1-136-165-00	FILM	0.1 $\mu$ F 5% 50V
	4-309-378-00	SPACER		C42	1-107-929-11	ELECT	10 $\mu$ F 20% 50V
	4-382-854-01	SCREW (M3X8), P, SW (+)		C43	1-107-929-11	ELECT	10 $\mu$ F 20% 50V
	*4-403-012-01	SPRING, STOPPER		C44	1-113-912-11	ELECT	0.0047 $\mu$ F 20% 250V
	*4-403-012-01	SPRING, STOPPER		C45	1-113-912-11	ELECT	0.0047 $\mu$ F 20% 250V
	*7-682-149-15	SCREW +P 3X10		C101	1-102-038-00	CERAMIC	0.001 $\mu$ F 500V
	*7-682-149-15	SCREW +P 3X10		C102	1-102-038-00	CERAMIC	0.001 $\mu$ F 500V
	7-682-566-04	SCREW +B 4X20		C103	1-102-228-00	CERAMIC	470pF 10% 500V
	7-682-566-04	SCREW +B 4X20		C104	1-102-228-00	CERAMIC	470pF 10% 500V
	7-682-661-01	SCREW +PS 4X8		C105	1-102-228-00	CERAMIC	470pF 10% 500V
	7-682-950-09	SCREW +PSW 3X12		C106	1-102-228-00	CERAMIC	470pF 10% 500V
	7-685-871-01	SCREW +BVTT 3X6 (S)		C107	1-107-877-11	ELECT	1000 $\mu$ F 20% 10V
	7-682-548-09	SCREW +BVTT 3X8 (S)		C108	1-107-877-11	ELECT	1000 $\mu$ F 20% 10V
		< CAPACITOR >		C109	1-107-877-11	ELECT	1000 $\mu$ F 20% 10V
				C110	1-107-877-11	ELECT	1000 $\mu$ F 20% 10V
				C111	1-102-038-00	CERAMIC	0.001 $\mu$ F 500V
C1	$\Delta$ 1-104-708-11	FILM	0.47 $\mu$ F 20% 250V	C112	1-102-038-00	CERAMIC	0.001 $\mu$ F 500V
C2	$\Delta$ 1-113-912-51	ELECT	0.0047 $\mu$ F 20% 250V	C113	1-102-228-00	CERAMIC	470pF 10% 500V
	*4-374-846-01	COVER, CAPACITOR, CAPTYPE (C2)		C114	1-102-228-00	CERAMIC	470pF 10% 500V
C3	$\Delta$ 1-113-912-51	ELECT	0.0047 $\mu$ F 20% 250V	C115	1-102-228-00	CERAMIC	470pF 10% 500V
	*4-374-846-01	COVER, CAPACITOR, CAPTYPE (C3)		C116	1-102-228-00	CERAMIC	470pF 10% 500V
C4	$\Delta$ 1-113-912-51	ELECT	0.0047 $\mu$ F 20% 250V	C117	1-128-528-11	ELECT	470 $\mu$ F 20% 25V
	*4-374-846-01	COVER, CAPACITOR, CAPTYPE (C4)		C118	1-126-105-11	ELECT	1000 $\mu$ F 20% 25V
C5	$\Delta$ 1-113-912-51	ELECT	0.0047 $\mu$ F 20% 250V	C119	1-128-528-11	ELECT	470 $\mu$ F 20% 25V
	*4-374-846-01	COVER, CAPACITOR, CAPTYPE (C5)		C120	1-126-105-11	ELECT	1000 $\mu$ F 20% 25V
C6	$\Delta$ 1-104-708-11	FILM	0.47 $\mu$ F 20% 250V	C121	1-102-228-00	CERAMIC	470pF 10% 500V
C9	$\Delta$ 1-113-924-91	ELECT	0.0047 $\mu$ F 20% 250V	C122	1-102-228-00	CERAMIC	470pF 10% 500V
C10	$\Delta$ 1-113-924-91	ELECT	0.0047 $\mu$ F 20% 250V	C123	1-107-877-11	ELECT	1000 $\mu$ F 20% 10V
C11	$\Delta$ 1-113-924-91	ELECT	0.0047 $\mu$ F 20% 250V	C124	1-126-771-11	ELECT	100 $\mu$ F 20% 160V
C12	$\Delta$ 1-113-924-91	ELECT	0.0047 $\mu$ F 20% 250V	C125	1-126-771-11	ELECT	100 $\mu$ F 20% 160V
C13	1-137-484-11	FILM	0.47 $\mu$ F 10% 630V	C126	1-136-165-00	FILM	0.1 $\mu$ F 5% 50V
C14	1-104-664-11	ELECT	47 $\mu$ F 20% 25V	C127	1-106-383-00	MYLAR	0.047 $\mu$ F 10% 200V
C15	1-128-526-11	ELECT	100 $\mu$ F 20% 16V	C128	1-107-880-11	ELECT	4700 $\mu$ F 20% 10V
C16	1-104-664-11	ELECT	47 $\mu$ F 20% 25V	C129	1-107-880-11	ELECT	4700 $\mu$ F 20% 10V
C17	1-107-896-11	ELECT	470 $\mu$ F 20% 35V	C130	1-107-880-11	ELECT	4700 $\mu$ F 20% 10V
C18	1-101-001-00	CERAMIC	0.001 $\mu$ F 50V	C131	1-107-880-11	ELECT	4700 $\mu$ F 20% 10V
C19	1-102-527-11	CERAMIC	82pF 5% 50V	C132	1-128-339-11	ELECT	2200 $\mu$ F 20% 10V
C20	1-130-471-00	FILM	0.001 $\mu$ F 5% 50V	C133	1-128-339-11	ELECT	2200 $\mu$ F 20% 10V
C21	1-136-177-00	FILM	1 $\mu$ F 5% 50V	C134	1-128-528-11	ELECT	470 $\mu$ F 20% 25V
C22	1-136-177-00	FILM	1 $\mu$ F 5% 50V	C135	1-104-664-11	ELECT	47 $\mu$ F 20% 25V
C23	1-136-165-00	FILM	0.1 $\mu$ F 5% 50V	C136	1-128-528-11	ELECT	470 $\mu$ F 20% 25V
C24	1-136-169-00	FILM	0.22 $\mu$ F 5% 50V	C137	1-104-664-11	ELECT	47 $\mu$ F 20% 25V
C25	1-130-471-00	FILM	0.001 $\mu$ F 5% 50V	C138	1-107-929-11	ELECT	10 $\mu$ F 20% 50V
C26	1-101-004-00	CERAMIC	0.01 $\mu$ F 50V	C139	1-107-929-11	ELECT	10 $\mu$ F 20% 50V
C27	1-126-804-11	ELECT	100 $\mu$ F 20% 35V	C140	1-136-175-00	FILM	0.68 $\mu$ F 5% 50V
C28	1-113-707-11	ELECT	220 $\mu$ F 20% 450V	C141	1-107-929-11	ELECT	10 $\mu$ F 20% 50V
C29	1-126-325-51	ELECT	3.3 $\mu$ F 20% 250V	C142	1-104-664-11	ELECT	47 $\mu$ F 20% 25V
C30	1-126-325-51	ELECT	3.3 $\mu$ F 20% 250V	C143	1-136-175-00	FILM	0.68 $\mu$ F 5% 50V
C31	1-102-038-00	CERAMIC	0.001 $\mu$ F 500V	C144	1-107-924-11	ELECT	0.47 $\mu$ F 20% 50V
C32	1-102-038-00	CERAMIC	0.001 $\mu$ F 500V				
C33	1-128-526-11	ELECT	100 $\mu$ F 20% 16V				
C34	1-104-664-11	ELECT	47 $\mu$ F 20% 25V				
C35	1-107-889-11	ELECT	220 $\mu$ F 20% 10V				
						< CONNECTOR >	
				CNI	1-564-321-00	PIN, CONNECTOR 2P	

The components identified by shading and marked  $\Delta$  are critical for safety.  
Replace only with the part number specified.

Les composants identifiés par une trame et une marque  $\Delta$  sont critiques pour la sécurité.  
Ne les remplacer que par une pièce portant le numéro spécifié.



REF NO.	PART NO.	DESCRIPTION	REMARK	REF NO.	PART NO.	DESCRIPTION	REMARK
CN2	1-568-106-11	PIN, CONNECTOR 4P				< FERRITE BEAD >	
CN3	1-774-523-11	PIN, CONNECTOR (PC BOARD) 64P					
CN4	1-774-530-11	CONNECTOR, BOARD TO BOARD 5P		FB1	1-410-396-41	FERRITE BEAD INDUCTOR	
CN5	1-774-531-11	CONNECTOR, BOARD TO BOARD 10P		FB2	1-410-396-41	FERRITE BEAD INDUCTOR	
				FB3	1-410-396-41	FERRITE BEAD INDUCTOR	
CN6	1-774-532-11	CONNECTOR, BOARD TO BOARD 15P		FB4	1-410-396-41	FERRITE BEAD INDUCTOR	
CN7	1-774-532-11	CONNECTOR, BOARD TO BOARD 15P		FB5	1-410-396-41	FERRITE BEAD INDUCTOR	
		< DIODE >		FB6	1-410-396-41	FERRITE BEAD INDUCTOR	
D1 $\Delta$	8-719-505-60	DIODE S5VB60				< IC >	
	*4-873-829-02	HEAT SINK (D1)		IC1	8-759-191-54	IC UC3854N	
	7-682-951-01	SCREW +PSW 3X14 (D1)		IC2	8-759-103-93	IC $\mu$ PC393C	
D2 $\Delta$	8-719-921-20	DIODE 1SS119-25TD		IC3	8-759-231-59	IC TA7815S	
D3	8-719-911-19	DIODE 1SS119-25		IC4	8-759-979-49	IC MA2820	
					*4-050-802-01	HEAT SINK (IC4)	
D7	8-719-110-03	DIODE RD7.5ESB2			*4-386-664-01	SPRING (IC4)	
D8	8-719-510-02	DIODE DINS4		IC101	8-759-908-15	IC TL431CLP	
D9	8-719-510-02	DIODE DINS4		IC102	8-759-346-48	IC SE005N	
D10	8-719-029-04	DIODE D5L60		IC103	8-759-908-15	IC TL431CLP	
	*4-381-905-01	SPRING (D) (D10)		IC104	8-759-231-58	IC TA7812S	
D11	8-719-510-02	DIODE DINS4				< CHIP CONDUCTOR >	
D12	8-719-510-02	DIODE DINS4		IC105	8-759-929-65	IC LM7912CT	
D13	8-719-110-49	DIODE RD18ESB2		IC106	8-759-103-93	IC $\mu$ PC393C	
D14	8-719-979-58	DIODE EGP10D				< COIL >	
D16	8-719-992-24	DIODE SLR-305VC3F		JR101	1-216-295-91	CONDUCTOR, CHIP (2012)	
D17	8-719-979-58	DIODE EGP10D				< COIL >	
D18	8-719-510-02	DIODE DINS4		L101	1-411-517-11	COIL, CHOKE 180 $\mu$ H	
D19	8-719-110-30	DIODE RD12ESB1		L102	1-406-661-11	COIL, CHOKE 22 $\mu$ H	
D20	8-719-992-24	DIODE SLR-305VC3F		L103	1-411-517-11	COIL, CHOKE 180 $\mu$ H	
D21	8-719-911-19	DIODE 1SS119-25		L104	1-406-661-11	COIL, CHOKE 22 $\mu$ H	
				L105	1-411-516-11	COIL, CHOKE 400 $\mu$ H	
D101	8-719-988-31	DIODE D10SC6MR		L106	1-406-661-11	COIL, CHOKE 22 $\mu$ H	
D102	8-719-510-09	DIODE D10SC6M		L107	1-411-516-11	COIL, CHOKE 400 $\mu$ H	
D103	8-719-500-42	DIODE D8LCA20R		L108	1-406-661-11	COIL, CHOKE 22 $\mu$ H	
D104	8-719-500-41	DIODE D8LCA20		L109	1-411-515-11	COIL, CHOKE 300mH	
D105	8-719-980-00	DIODE ESAC39M-06N		L110	1-406-661-11	COIL, CHOKE 22 $\mu$ H	
D106	8-719-971-08	DIODE ESAC39M-06C		L111	1-406-659-11	COIL, CHOKE 10 $\mu$ H	
D107	8-719-510-09	DIODE D10SC6M				< PHOTO COUPLER >	
	*4-050-800-01	PLETE (SMALL), NUT (D107)		PC1 $\Delta$	8-749-923-50	PHOTO COUPLER PC111YS	
D108	8-719-979-58	DIODE EGP10D		PC2 $\Delta$	8-749-923-50	PHOTO COUPLER PC111YS	
D109	8-719-110-42	DIODE RD15ESB3		PC3 $\Delta$	8-749-923-50	PHOTO COUPLER PC111YS	
D110	8-719-979-58	DIODE EGP10D		PC4 $\Delta$	8-749-923-50	PHOTO COUPLER PC111YS	
D111	8-719-110-42	DIODE RD15ESB3				< TRANSISTOR >	
D112	8-719-992-30	DIODE SLR-305MC3F		Q1	8-729-119-78	TRANSISTOR 2SC2785-HFE	
D113	8-719-911-19	DIODE 1SS119-25		Q2	8-729-030-03	TRANSISTOR DTC144ESA-TP	
D114	8-719-911-19	DIODE 1SS119-25		Q3	8-729-119-78	TRANSISTOR 2SC2785-HFE	
D115 $\Delta$	8-719-921-20	DIODE 1SS119-25TD		Q4	8-729-119-76	TRANSISTOR 2SA1175-HFE	
D116	8-719-109-72	DIODE RD3.9ESB2		Q5	8-729-024-29	TRANSISTOR IRFP450LF	
D117	8-719-109-93	DIODE RD6.2ESB2				< TRANSISTOR >	
D118	8-719-110-17	DIODE RD10ESB2		Q6	8-729-024-29	TRANSISTOR IRFP450LF	
		< FUSE >		Q7	8-729-024-29	TRANSISTOR IRFP450LF	
F1 $\Delta$	1-532-746-11	FUSE GLASS, TUBE (4A/125V) (14E1U/14E5U/14F1U/14F5U/20E1U/20F1U)		Q8	8-729-034-17	TRANSISTOR 2SC3632-L	
F1 $\Delta$	1-576-230-11	FUSE (H.B.C) (T3.15A/250V) (14E1E/14E5E/14F1E/14F5E/20E1E/20F1E)					
	*1-533-701-11	HOLDER, FUSE (F1)					

Les composants identifiés par une trame et une marque  $\Delta$  sont critiques pour la sécurité.  
Ne les remplacer que par une pièce portant le numéro spécifié.

The components identified by shading and marked  $\Delta$  are critical for safety.  
Replace only with the part number specified.

G

REF NO.	PART NO.	DESCRIPTION	REMARK	REF NO.	PART NO.	DESCRIPTION	REMARK
Q9	8-729-118-44	TRANSISTOR 2SA1413-K		R45	1-249-393-11	CARBON 10	5% 1/4W
Q10	8-729-030-03	TRANSISTOR DTC144ESA-TP		R46	1-249-429-11	CARBON 10K	5% 1/4W
Q11	8-729-029-56	TRANSISTOR DTA144ESA		R47	1-249-393-11	CARBON 10	5% 1/4W
Q12	8-729-030-03	TRANSISTOR DTC144ESA-TP		R48	1-249-429-11	CARBON 10K	5% 1/4W
Q13	8-729-030-03	TRANSISTOR DTC144ESA-TP		R49	1-219-728-11	WIREWOUND 0.22	10% 5W
Q14	8-729-030-03	TRANSISTOR DTC144ESA-TP		R50	1-249-417-11	CARBON 1K	5% 1/4W
Q15	8-729-029-56	TRANSISTOR DTA144ESA		R51	1-249-441-11	CARBON 100K	5% 1/4W
Q16	8-729-030-03	TRANSISTOR DTC144ESA-TP		R52	1-215-911-11	METAL OXIDE 100	5% 3W F
Q17	8-729-029-56	TRANSISTOR DTA144ESA		R53	1-215-911-11	METAL OXIDE 100	5% 3W F
Q101	8-729-030-03	TRANSISTOR DTC144ESA-TP		R59	1-202-719-00	SOLID 1M	20% 1/2W
Q103	8-729-030-03	TRANSISTOR DTC144ESA-TP		R61	1-215-904-11	METAL OXIDE 100K	5% 2W F
Q104	8-729-119-78	TRANSISTOR 2SC2785-HFE		R62	1-249-409-11	CARBON 220	5% 1/4W F
Q105	8-729-030-03	TRANSISTOR DTC144ESA-TP		R63	1-216-426-11	METAL OXIDE 82	5% 1W F
Q107	8-729-119-78	TRANSISTOR 2SC2785-HFE		R64	1-216-426-11	METAL OXIDE 82	5% 1W F
Q108	8-729-029-56	TRANSISTOR DTA144ESA		R65	$\Delta$ 1-202-725-51	METAL 3.3M	5% 1W
Q109	8-729-030-03	TRANSISTOR DTC144ESA-TP		R66	1-247-895-91	CARBON 220K	5% 1/4W
		< RESISTOR >		R67	1-247-895-91	CARBON 220K	5% 1/4W
R1	$\Delta$ 1-202-884-91	SOLID 820K	20% 1/2W	R68	1-249-429-11	CARBON 10K	5% 1/4W
R2	$\Delta$ 1-202-962-11	WIREWOUND 3.3	5% 10W	R69	1-249-429-11	CARBON 10K	5% 1/4W
R3	1-247-737-11	CARBON 68	5% 1/2W	R70	1-247-887-00	CARBON 220K	5% 1/4W
R4	1-249-437-11	CARBON 47K	5% 1/4W	R71	1-247-887-00	CARBON 220K	5% 1/4W
R5	1-247-863-91	CARBON 22K	5% 1/4W	R72	1-247-895-91	CARBON 470K	5% 1/4W
R7	1-247-863-91	CARBON 22K	5% 1/4W	R73	1-247-895-91	CARBON 470K	5% 1/4W
R8	1-249-417-11	CARBON 1K	5% 1/4W	R74	1-247-863-91	CARBON 22K	5% 1/4W
R9	1-249-441-11	CARBON 100K	5% 1/4W	R75	1-249-417-11	CARBON 1K	5% 1/4W
R10	1-249-429-11	CARBON 10K	5% 1/4W	R76	$\Delta$ 1-202-725-51	METAL 3.3M	10% 1/2W
R11	1-249-429-11	CARBON 10K	5% 1/4W	R77	1-215-431-00	METAL OXIDE 2.7K	0.5% 1/4W
R12	1-247-863-91	CARBON 22K	5% 1/4W	R79	1-215-481-00	METAL 330K	0.5% 1/4W
R13	1-249-425-11	CARBON 4.7K	5% 1/4W	R101	1-215-884-11	METAL OXIDE 47	5% 2W F
R14	1-215-449-51	METAL 15K	1% 1/4W	R102	1-216-341-11	METAL OXIDE 0.22	5% 1W F
R15	1-215-445-00	METAL 10K	1% 1/4W	R103	1-216-341-11	METAL OXIDE 0.22	5% 1W F
R16	1-215-445-00	METAL 10K	1% 1/4W	R104	1-216-341-11	METAL OXIDE 0.22	5% 1W F
R18	1-215-423-00	METAL 1.2K	1% 1/4W	R105	1-216-341-11	METAL OXIDE 0.22	5% 1W F
R19	1-215-442-00	METAL 7.5K	1% 1/4W	R106	1-216-341-11	METAL OXIDE 0.22	5% 1W F
R20	1-247-863-91	CARBON 22K	5% 1/4W	R107	1-216-341-11	METAL OXIDE 0.22	5% 1W F
R21	1-215-435-00	METAL 3.9K	1% 1/4W	R108	1-215-884-11	METAL OXIDE 47	5% 2W F
R22	1-215-435-00	METAL 3.9K	1% 1/4W	R109	1-216-341-11	METAL OXIDE 0.22	5% 1W F
R23	1-247-887-00	CARBON 220K	5% 1/4W	R110	1-216-341-11	METAL OXIDE 0.22	5% 1W F
R24	1-247-895-91	CARBON 470K	5% 1/4W	R111	1-216-341-11	METAL OXIDE 0.22	5% 1W F
R25	1-247-895-91	CARBON 470K	5% 1/4W	R112	1-216-341-11	METAL OXIDE 0.22	5% 1W F
R26	1-247-895-91	CARBON 470K	5% 1/4W	R113	1-216-736-11	METAL 270	1% 10W
R27	1-247-895-91	CARBON 470K	5% 1/4W		*4-050-800-01	PLETE (SMALL), NUT (R113)	
R28	1-247-887-00	CARBON 220K	5% 1/4W	R114	1-219-728-11	WIREWOUND 0.22	10% 5W
R29	1-247-863-91	CARBON 22K	5% 1/4W	R115	1-215-901-00	METAL OXIDE 33K	5% 2W F
R30	1-247-863-91	CARBON 22K	5% 1/4W	R116	1-249-429-11	CARBON 10K	5% 1/4W
R31	1-247-887-00	CARBON 220K	5% 1/4W	R117	1-249-409-11	CARBON 220	5% 1/4W F
R32	1-215-447-00	METAL 12K	1% 1/4W	R118	1-249-413-11	CARBON 470	5% 1/4W F
R33	1-249-393-11	CARBON 10	5% 1/4W	R119	1-214-905-00	METAL 47K	1% 1/2W
R34	1-249-429-11	CARBON 10K	5% 1/4W	R120	1-214-905-00	METAL 47K	1% 1/2W
R39	1-215-481-00	METAL 330K	1% 1/4W	R121	1-215-427-00	METAL 1.8K	1% 1/4W
R40	1-215-481-00	METAL 330K	1% 1/4W	R122	1-215-397-00	METAL 100	1% 1/4W
R42	1-219-440-11	WIREWOUND 0.47	10% 5W	R123	1-214-921-00	METAL 220K	1% 1/2W
R43	1-219-440-11	WIREWOUND 0.47	10% 5W	R125	1-249-417-11	CARBON 1K	5% 1/4W
				R129	1-249-413-11	CARBON 470	5% 1/4W



The components identified by shading and marked  $\Delta$  are critical for safety.  
Replace only with the part number specified.

Les composants identifiés par une trame et une marque  $\Delta$  sont critiques pour la sécurité.  
Ne les remplacer que par une pièce portant le numéro spécifié.

The components identified by  $\boxtimes$  in this manual have been carefully factory-selected for each set in order to satisfy regulations regarding X-ray radiation.  
Should replacement be required, replace only with the value originally used.



REF NO.	PART NO.	DESCRIPTION	REMARK	REF NO.	PART NO.	DESCRIPTION	REMARK
R130	1-215-431-00	METAL	2.7K 1% 1/4W				
R131	1-215-429-00	METAL	2.2K 1% 1/4W				
R132	1-247-815-91	CARBON	220 5% 1/4W				
R135	1-249-417-11	CARBON	1K 5% 1/4W				
R136	1-247-863-91	CARBON	22K 5% 1/4W				
R137	1-249-437-11	CARBON	47K 5% 1/4W				
R138	1-249-427-11	CARBON	6.8K 5% 1/4W				
R139	1-249-425-11	CARBON	4.7K 5% 1/4W				
R141	1-249-429-11	CARBON	10K 5% 1/4W				
R142	1-249-417-11	CARBON	1K 5% 1/4W				
R143	1-247-895-91	CARBON	470K 5% 1/4W				
R144	1-249-429-11	CARBON	10K 5% 1/4W				
R145	1-249-429-11	CARBON	10K 5% 1/4W				
R146	1-249-429-11	CARBON	10K 5% 1/4W				
R147	1-249-393-11	CARBON	10 5% 1/4W				
R148	1-249-393-11	CARBON	10 5% 1/4W				
		< VARIABLE RESISTOR >					
$\boxtimes$ RV101 $\Delta$	1-241-759-21	RES. ADJ, CERMET	220				
		< RELAY >					
RY1 $\Delta$	1-515-738-11	RELAY					
RY2 $\Delta$	1-515-738-11	RELAY					
		< SWITCH >					
S901 $\Delta$	1-762-300-11	SWITCH, AC POWER SEESAW					
		< TRANSFORMER >					
T1 $\Delta$	1-423-333-11	TRANSFORMER, LINE FILTER					
T2 $\Delta$	1-423-333-11	TRANSFORMER, LINE FILTER					
T3	1-429-283-11	TRANSFORMER, CONVERTER (PFT)					
T4 $\Delta$	1-429-347-11	TRANSFORMER, CONVERTER (SRT)					
T5	1-429-351-11	TRANSFORMER, CONVERTER (SRT)					
		< THERMISTOR >					
THP1 $\Delta$	1-808-059-31	THERMISTOR, POSITIVE					
		< TEST PIN >					
TP2	1-537-864-11	PIN, POST					
TP3	1-537-864-11	PIN, POST					
TP105	1-537-864-11	PIN, POST					
TP106	1-537-864-11	PIN, POST					
TP107	1-537-864-11	PIN, POST					
TP108	1-537-864-11	PIN, POST					
TP109	1-537-864-11	PIN, POST					
		< VARISTOR >					
VDR1 $\Delta$	1-809-581-11	VARISTOR					
	*4-374-846-01	COVER, CAPACITOR, CAP TYPE (VDR1)					
VDR2 $\Delta$	1-810-622-11	VARISTOR					
*****							
		< CAPACITOR >					
	*A-1311-432-A	MOUNTED PCB, GA					
		*****					
C101	1-164-004-11	CERAMIC CHIP	0.1 $\mu$ F 10% 25V				
C102	1-164-004-11	CERAMIC CHIP	0.1 $\mu$ F 10% 25V				
C104	1-164-004-11	CERAMIC CHIP	0.1 $\mu$ F 10% 25V				
C105	1-164-004-11	CERAMIC CHIP	0.1 $\mu$ F 10% 25V				
C106	1-164-004-11	CERAMIC CHIP	0.1 $\mu$ F 10% 25V				
C107	1-104-539-11	FILM CHIP	0.001 $\mu$ F 5% 50V				
C108	1-126-400-11	ELECT CHIP	22 $\mu$ F 20% 35V				
C110	1-126-400-11	ELECT CHIP	22 $\mu$ F 20% 35V				
C111	1-164-004-11	CERAMIC CHIP	0.1 $\mu$ F 10% 25V				
C113	1-126-400-11	ELECT CHIP	22 $\mu$ F 20% 35V				
		< CONNECTOR >					
CN101	1-774-551-11	CONNECTOR, BOARD TO BOARD 5P					
CN102	1-774-552-11	CONNECTOR, BOARD TO BOARD 10P					
		< DIODE >					
D101	8-719-404-46	DIODE MA110					
D102	8-719-989-21	DIODE SC311-6-TE12RA					
D103	8-719-989-21	DIODE SC311-6-TE12RA					
D104	8-719-107-15	DIODE RD18M-B2					
D105	8-719-404-46	DIODE MA110					
D106	8-719-404-46	DIODE MA110					
D107	8-719-404-46	DIODE MA110					
D108	8-719-404-46	DIODE MA110					
		< IC >					
IC101	8-759-185-47	IC IR2112					
IC102	8-759-914-04	IC TL494CNS					
		< TRANSISTOR >					
Q101	8-729-120-28	TRANSISTOR 2SC1623-L5L6					
Q102	8-729-216-22	TRANSISTOR 2SA1162-G					
		< RESISTOR >					
R103	1-216-049-91	METAL GLAZE	1K 5% 1/10W				
R104	1-216-043-91	METAL GLAZE	560 5% 1/10W				
R105	1-216-043-91	METAL GLAZE	560 5% 1/10W				
R106	1-208-806-11	METAL CHIP	10K 0.50% 1/10W				
R107	1-216-637-11	METAL CHIP	270 0.50% 1/10W				
R108	1-216-041-00	METAL GLAZE	470 5% 1/10W				
R109	1-216-073-00	METAL GLAZE	10K 5% 1/10W				
R110	1-216-073-00	METAL GLAZE	10K 5% 1/10W				
R111	1-216-057-00	METAL GLAZE	2.2K 5% 1/10W				
R112	1-216-655-11	METAL CHIP	1.5K 0.50% 1/10W				
R113	1-216-677-11	METAL CHIP	12K 0.50% 1/10W				
R114	1-208-814-11	METAL CHIP	22K 0.50% 1/10W				
R115	1-216-081-00	METAL GLAZE	22K 5% 1/10W				
R116	1-216-085-00	METAL GLAZE	33K 5% 1/10W				
R119	1-216-097-91	METAL GLAZE	100K 5% 1/10W				
R120	1-216-001-00	METAL GLAZE	10 5% 1/10W				



REF NO.	PART NO.	DESCRIPTION	REMARK			REF NO.	PART NO.	DESCRIPTION	REMARK								
R121	1-216-001-00	METAL GLAZE	10	5%	1/10W			< IC >									
*****																	
	*A-1311-433-A	MOUNTED PCB, GB	*****														
		< CAPACITOR >															
C201	1-164-004-11	CERAMIC CHIP	0.1μ F	10%	25V	IC201	8-759-908-15	IC TL431CLP									
C202	1-124-779-00	ELECT	10μ F	20%	16V	IC202	8-759-988-13	IC LM393PS									
C203	1-164-004-11	CERAMIC CHIP	0.1μ F	10%	25V	IC203	8-759-085-67	IC LM339NS									
C204	1-124-779-00	ELECT	10μ F	20%	16V	IC204	8-759-085-67	IC LM339NS									
C205	1-164-232-11	CERAMIC CHIP	0.01μ F	10%	50V	IC301	8-759-926-14	IC SN74HC148NS									
C206	1-128-007-11	ELECT CHIP	2.2μ F	20%	35V	IC302	8-759-926-14	IC SN74HC148NS									
C207	1-128-007-11	ELECT CHIP	2.2μ F	20%	35V	IC303	8-759-032-14	IC MC74HC08AF									
C208	1-128-007-11	ELECT CHIP	2.2μ F	20%	35V			< TRANSISTOR >									
C209	1-128-007-11	ELECT CHIP	2.2μ F	20%	35V	Q301	8-729-907-46	TRANSISTOR IMZ1									
C210	1-126-935-11	ELECT	470μ F	20%	6.3V	Q302	8-729-907-46	TRANSISTOR IMZ1									
C301	1-128-007-11	ELECT CHIP	2.2μ F	20%	35V	Q303	8-729-907-46	TRANSISTOR IMZ1									
C302	1-128-007-11	ELECT CHIP	2.2μ F	20%	35V	Q304	8-729-907-46	TRANSISTOR IMZ1									
C303	1-128-007-11	ELECT CHIP	2.2μ F	20%	35V	Q305	8-729-907-46	TRANSISTOR IMZ1									
C304	1-128-007-11	ELECT CHIP	2.2μ F	20%	35V	Q306	8-729-907-46	TRANSISTOR IMZ1									
C305	1-128-007-11	ELECT CHIP	2.2μ F	20%	35V	Q307	8-729-907-46	TRANSISTOR IMZ1									
C306	1-128-007-11	ELECT CHIP	2.2μ F	20%	35V	Q308	8-729-907-46	TRANSISTOR IMZ1									
C307	1-128-007-11	ELECT CHIP	2.2μ F	20%	35V	Q309	8-729-907-46	TRANSISTOR IMZ1									
C308	1-128-007-11	ELECT CHIP	2.2μ F	20%	35V	Q310	8-729-907-46	TRANSISTOR IMZ1									
C309	1-128-007-11	ELECT CHIP	2.2μ F	20%	35V	Q311	8-729-216-22	TRANSISTOR 2SA1162-G									
C310	1-128-007-11	ELECT CHIP	2.2μ F	20%	35V	Q312	8-729-027-38	TRANSISTOR DTA144EKA-T146									
C311	1-164-004-11	CERAMIC CHIP	0.1μ F	10%	25V	Q313	8-729-027-38	TRANSISTOR DTA144EKA-T146									
C312	1-126-964-51	ELECT	10μ F	20%	50V			< RESISTOR >									
		< CONNECTOR >															
CN301	1-774-553-11	CONNECTOR, BOARD TO BOARD 15P										R201	1-216-057-00	METAL GLAZE	2.2K	5%	1/10W
CN302	1-774-553-11	CONNECTOR, BOARD TO BOARD 15P										R202	1-216-661-11	METAL CHIP	2.7K	0.50%	1/10W
		< DIODE >										R203	1-216-639-11	METAL CHIP	330	0.50%	1/10W
D201	8-719-105-91	DIODE RD5.6M-B2										R204	1-216-037-00	METAL GLAZE	330	5%	1/10W
D202	8-719-404-46	DIODE MA110										R205	1-216-081-00	METAL GLAZE	22K	5%	1/10W
D203	8-719-404-46	DIODE MA110										R207	1-216-674-11	METAL CHIP	9.1K	0.50%	1/10W
D204	8-719-404-46	DIODE MA110										R208	1-216-051-00	METAL GLAZE	1.2K	5%	1/10W
D205	8-719-404-46	DIODE MA110										R209	1-216-081-00	METAL GLAZE	22K	5%	1/10W
D206	8-719-105-91	DIODE RD5.6M-B2										R210	1-216-667-11	METAL CHIP	4.7K	0.50%	1/10W
D301	8-719-404-46	DIODE MA110										R211	1-208-801-11	METAL CHIP	6.2K	0.50%	1/10W
D302	8-719-404-46	DIODE MA110										R212	1-216-667-11	METAL CHIP	4.7K	0.50%	1/10W
D303	8-719-404-46	DIODE MA110										R213	1-216-699-11	METAL CHIP	100K	0.50%	1/10W
D304	8-719-404-46	DIODE MA110										R214	1-208-801-11	METAL CHIP	6.2K	0.50%	1/10W
D305	8-719-404-46	DIODE MA110										R215	1-216-089-91	METAL GLAZE	47K	5%	1/10W
D306	8-719-404-46	DIODE MA110										R216	1-216-077-00	METAL GLAZE	15K	5%	1/10W
D307	8-719-404-46	DIODE MA110										R217	1-216-081-00	METAL GLAZE	22K	5%	1/10W
D308	8-719-404-46	DIODE MA110										R218	1-216-677-11	METAL CHIP	12K	0.50%	1/10W
D309	8-719-404-46	DIODE MA110										R219	1-216-667-11	METAL CHIP	4.7K	0.50%	1/10W
D310	8-719-404-46	DIODE MA110										R220	1-216-081-00	METAL GLAZE	22K	5%	1/10W
												R221	1-216-667-11	METAL CHIP	4.7K	0.50%	1/10W
												R222	1-208-801-11	METAL CHIP	6.2K	0.50%	1/10W
												R223	1-216-667-11	METAL CHIP	4.7K	0.50%	1/10W
												R224	1-216-699-11	METAL CHIP	100K	0.50%	1/10W
												R225	1-208-801-11	METAL CHIP	6.2K	0.50%	1/10W
												R226	1-216-089-91	METAL GLAZE	47K	5%	1/10W
												R227	1-216-077-00	METAL GLAZE	15K	5%	1/10W
												R228	1-216-081-00	METAL GLAZE	22K	5%	1/10W
												R229	1-216-677-11	METAL CHIP	12K	0.50%	1/10W
												R230	1-216-667-11	METAL CHIP	4.7K	0.50%	1/10W

REF NO.	PART NO.	DESCRIPTION	REMARK	REF NO.	PART NO.	DESCRIPTION	REMARK
R231	1-216-081-00	METAL GLAZE	22K 5% 1/10W	R335	1-216-073-00	METAL GLAZE	10K 5% 1/10W
R232	1-216-637-11	METAL CHIP	270 0.50% 1/10W	R336	1-216-073-00	METAL GLAZE	10K 5% 1/10W
R233	1-208-801-11	METAL CHIP	6.2K 0.50% 1/10W	R337	1-216-073-00	METAL GLAZE	10K 5% 1/10W
R234	1-208-806-11	METAL CHIP	10K 0.50% 1/10W	R338	1-216-065-00	METAL GLAZE	4.7K 5% 1/10W
R235	1-216-089-91	METAL GLAZE	47K 5% 1/10W	R339	1-216-073-00	METAL GLAZE	10K 5% 1/10W
R236	1-216-077-00	METAL GLAZE	15K 5% 1/10W	R340	1-216-073-00	METAL GLAZE	10K 5% 1/10W
R237	1-216-081-00	METAL GLAZE	22K 5% 1/10W	R342	1-216-073-00	METAL GLAZE	10K 5% 1/10W
R238	1-216-659-11	METAL CHIP	2.2K 0.50% 1/10W	R343	1-216-073-00	METAL GLAZE	10K 5% 1/10W
R239	1-216-667-11	METAL CHIP	4.7K 0.50% 1/10W	R344	1-216-025-91	METAL GLAZE	100 5% 1/10W
R240	1-216-081-00	METAL GLAZE	22K 5% 1/10W	R345	1-216-025-91	METAL GLAZE	100 5% 1/10W
R241	1-216-637-11	METAL CHIP	270 0.50% 1/10W	R346	1-216-025-91	METAL GLAZE	100 5% 1/10W
R242	1-208-801-11	METAL CHIP	6.2K 0.50% 1/10W	R347	1-216-025-91	METAL GLAZE	100 5% 1/10W
R243	1-208-806-11	METAL CHIP	10K 0.50% 1/10W	*****			
R244	1-216-077-00	METAL GLAZE	15K 5% 1/10W	* A-1311-467-A MOUNTED PCB, GC			
R245	1-216-089-91	METAL GLAZE	47K 5% 1/10W	*****			
R246	1-216-081-00	METAL GLAZE	22K 5% 1/10W	< CAPACITOR >			
R247	1-216-659-11	METAL CHIP	2.2K 0.50% 1/10W	C1	1-124-288-00	ELECT	22μ F 20% 10V
R248	1-216-667-11	METAL CHIP	4.7K 0.50% 1/10W	C2	1-128-551-11	ELECT	22μ F 20% 25V
R249	1-216-051-00	METAL GLAZE	1.2K 5% 1/10W	< CONNECTOR >			
R250	1-216-081-00	METAL GLAZE	22K 5% 1/10W	CN2	1-770-374-11	PIN, CONNECTOR BOARD TO BOARD 5P	
R301	1-216-073-00	METAL GLAZE	10K 5% 1/10W	< IC >			
R302	1-216-065-00	METAL GLAZE	4.7K 5% 1/10W	IC1	8-759-135-80	IC μ PC358C	
R303	1-216-073-00	METAL GLAZE	10K 5% 1/10W	< TRANSISTOR >			
R304	1-216-073-00	METAL GLAZE	10K 5% 1/10W	Q1	8-729-030-03	TRANSISTOR DTC144ESA-TP	
R305	1-216-073-00	METAL GLAZE	10K 5% 1/10W	< RESISTOR >			
R306	1-216-065-00	METAL GLAZE	4.7K 5% 1/10W	R1	1-249-441-11	CARBON	100K 5% 1/4W
R307	1-216-073-00	METAL GLAZE	10K 5% 1/10W	R2	1-249-437-11	CARBON	47K 5% 1/4W
R308	1-216-073-00	METAL GLAZE	10K 5% 1/10W	R3	1-215-477-00	METAL	220K 1% 1/4W
R309	1-216-073-00	METAL GLAZE	10K 5% 1/10W	R4	1-215-477-00	METAL	220K 1% 1/4W
R310	1-216-065-00	METAL GLAZE	4.7K 5% 1/10W	R5	1-215-477-00	METAL	220K 1% 1/4W
R311	1-216-073-00	METAL GLAZE	10K 5% 1/10W	R6	1-215-447-00	METAL	12K 1% 1/4W
R312	1-216-073-00	METAL GLAZE	10K 5% 1/10W	R7	1-215-417-00	METAL	680 1% 1/4W
R313	1-216-073-00	METAL GLAZE	10K 5% 1/10W	R8	1-215-439-00	METAL	5.6K 1% 1/4W
R314	1-216-065-00	METAL GLAZE	4.7K 5% 1/10W	R9	1-215-477-00	METAL	220K 1% 1/4W
R315	1-216-073-00	METAL GLAZE	10K 5% 1/10W	R10	1-215-477-00	METAL	220K 1% 1/4W
R316	1-216-073-00	METAL GLAZE	10K 5% 1/10W	R11	1-215-477-00	METAL	220K 1% 1/4W
R317	1-216-073-00	METAL GLAZE	10K 5% 1/10W	R12	1-215-442-00	METAL	7.5K 1% 1/4W
R318	1-216-065-00	METAL GLAZE	4.7K 5% 1/10W	R13	1-247-807-31	CARBON	100 5% 1/4W
R319	1-216-073-00	METAL GLAZE	10K 5% 1/10W	*****			
R320	1-216-073-00	METAL GLAZE	10K 5% 1/10W				
R321	1-216-073-00	METAL GLAZE	10K 5% 1/10W				
R322	1-216-065-00	METAL GLAZE	4.7K 5% 1/10W				
R323	1-216-073-00	METAL GLAZE	10K 5% 1/10W				
R324	1-216-073-00	METAL GLAZE	10K 5% 1/10W				
R325	1-216-073-00	METAL GLAZE	10K 5% 1/10W				
R326	1-216-065-00	METAL GLAZE	4.7K 5% 1/10W				
R327	1-216-073-00	METAL GLAZE	10K 5% 1/10W				
R328	1-216-073-00	METAL GLAZE	10K 5% 1/10W				
R329	1-216-073-00	METAL GLAZE	10K 5% 1/10W				
R330	1-216-065-00	METAL GLAZE	4.7K 5% 1/10W				
R331	1-216-073-00	METAL GLAZE	10K 5% 1/10W				
R332	1-216-073-00	METAL GLAZE	10K 5% 1/10W				
R333	1-216-073-00	METAL GLAZE	10K 5% 1/10W				
R334	1-216-065-00	METAL GLAZE	4.7K 5% 1/10W				



Les composants identifiés par une trame et une marque  $\Delta$  sont critiques pour la sécurité.  
Ne les remplacer que par une pièce portant le numéro spécifié.

The components identified by shading and marked  $\Delta$  are critical for safety.  
Replace only with the part number specified.

REF NO.	PART NO.	DESCRIPTION	REMARK	REF NO.	PART NO.	DESCRIPTION	REMARK
	*A-1331-457-A	MOUNTED PCB, C (14F1E/14F1U/14F5E/14F5U/ 20F1E/20F1U) *****		R11	1-202-537-00	SOLID 33 20% 1/2W	
	*A-1331-520-A	MOUNTED PCB, C (14E1E/14E1U/14E5E/14E5U/ 20E1E/20E1U) *****		R12	1-202-537-00	SOLID 33 20% 1/2W	
		< CAPACITOR >		R13	1-202-559-00	SOLID 270 20% 1/2W	
C1	1-102-316-00	CERAMIC 15pF 5% 500V		R14	1-202-559-00	SOLID 270 20% 1/2W	
C2	1-102-316-00	CERAMIC 15pF 5% 500V		R15	1-202-559-00	SOLID 270 20% 1/2W	
C3	1-102-316-00	CERAMIC 15pF 5% 500V		R16	1-202-842-11	SOLID 220K 20% 1/2W	
C4	1-162-114-00	CERAMIC 0.0047 $\mu$ F 2KV		R17	1-249-430-11	CARBON 12K 5% 1/4W (14F1E/14F1U/14F5E/14F5U/20F1E/20F1U)	
C5	1-162-114-00	CERAMIC 0.0047 $\mu$ F 2KV		R18	1-249-426-11	CARBON 5.6K 5% 1/4W (14F1E/14F1U/14F5E/14F5U/20F1E/20F1U)	
C6	1-162-114-00	CERAMIC 0.0047 $\mu$ F 2KV				< VARIABLE RESISTOR >	
C7	1-124-907-11	ELECT 10 $\mu$ F 20% 50V		RV1	1-223-410-11	RES, ADJ, METAL FILM 110M (H STAT)	
C8	1-124-907-11	ELECT 10 $\mu$ F 20% 50V				< SPARK GAP >	
		< CONNECTOR >		SG1	1-519-422-11	GAP, SPARK	
CN1	*1-508-786-00	PIN, CONNECTOR (5MM PITCH) 2P		SG2	1-519-421-11	GAP, DISCHARGE	
CN2	1-508-784-00	PIN, CONNECTOR (5MM PITCH) 1P		SG3	1-519-421-11	GAP, DISCHARGE	
CN3	*1-766-241-11	PIN, CONNECTOR (PC BOARD) 3P		SG4	1-519-421-11	GAP, DISCHARGE	
CN4	*1-564-507-11	PLUG, CONNECTOR 4P		SG5	1-519-421-11	GAP, DISCHARGE	
CN5	*1-564-507-11	PLUG, CONNECTOR 4P		SG6	1-519-421-11	GAP, DISCHARGE	
CN6	*1-564-507-11	PLUG, CONNECTOR 4P		SG7	1-519-421-11	GAP, DISCHARGE	
CN7	*1-564-506-11	PLUG, CONNECTOR 3P		SG8	1-519-422-11	GAP, SPARK	
CN8	*1-564-507-11	PLUG, CONNECTOR 4P				*****	
		< DIODE >		*A-1341-958-B	MOUNTED PCB, D *****		
D1	8-719-979-58	DIODE EGP10D				< CAPACITOR >	
D2	8-719-110-63	DIODE RD24ESB3 (14F1E/14F1U/14F5E/14F5U/20F1E/20F1U)		C103	1-126-396-11	ELECT CHIP 47 $\mu$ F 20% 16V	
		< SOCKET >		C104	1-126-396-11	ELECT CHIP 47 $\mu$ F 20% 16V	
J1 $\Delta$	1-251-116-12	SOCKET, CRT		C109	1-126-401-11	ELECT CHIP 1 $\mu$ F 20% 50V	
		< COIL >		C114	1-163-031-11	CERAMIC CHIP 0.01 $\mu$ F 50V	
L1	1-408-401-00	INDUCTOR 2.2 $\mu$ H		C115	1-163-031-11	CERAMIC CHIP 0.01 $\mu$ F 50V	
L2	1-408-401-00	INDUCTOR 2.2 $\mu$ H		C116	1-126-396-11	ELECT CHIP 47 $\mu$ F 20% 16V	
L3	1-408-401-00	INDUCTOR 2.2 $\mu$ H		C118	1-163-038-91	CERAMIC CHIP 0.1 $\mu$ F 25V	
		< TRANSISTOR >		C121	1-126-391-11	ELECT CHIP 47 $\mu$ F 20% 6.3V	
Q1	8-729-140-97	TRANSISTOR 2SB734-34		C122	1-104-555-11	FILM CHIP 0.022 $\mu$ F 5% 16V	
		< RESISTOR >		C123	1-107-561-11	FILM CHIP 0.01 $\mu$ F 5% 50V	
R1	1-202-561-00	SOLID 330 20% 1/2W		C124	1-163-031-11	CERAMIC CHIP 0.01 $\mu$ F 50V	
R2	1-202-561-00	SOLID 330 20% 1/2W		C126	1-104-563-11	FILM CHIP 0.1 $\mu$ F 5% 16V	
R3	1-202-561-00	SOLID 330 20% 1/2W		C127	1-163-031-11	CERAMIC CHIP 0.01 $\mu$ F 50V	
R4	1-202-820-11	SOLID 1.5K 20% 1/2W		C128	1-163-031-11	CERAMIC CHIP 0.01 $\mu$ F 50V	
R5	1-202-820-11	SOLID 1.5K 20% 1/2W		C131	1-107-682-11	CERAMIC CHIP 1 $\mu$ F 10% 16V	
R6	1-202-820-11	SOLID 1.5K 20% 1/2W		C132	1-104-559-11	FILM CHIP 0.047 $\mu$ F 5% 16V	
R7	1-219-696-11	METAL OXIDE 30M 5% 1W		C133	1-107-682-11	CERAMIC CHIP 1 $\mu$ F 10% 16V	
R8	1-202-838-00	SOLID 100K 20% 1/2W		C134	1-163-038-91	CERAMIC CHIP 0.1 $\mu$ F 25V	
R9	1-202-719-00	SOLID 1M 10% 1/2W		C135	1-163-031-11	CERAMIC CHIP 0.01 $\mu$ F 50V	
R10	1-202-537-00	SOLID 33 20% 1/2W		C136	1-126-391-11	ELECT CHIP 47 $\mu$ F 20% 6.3V	
				C137	1-163-038-91	CERAMIC CHIP 0.1 $\mu$ F 25V	
				C138	1-163-038-91	CERAMIC CHIP 0.1 $\mu$ F 25V	
				C139	1-163-038-91	CERAMIC CHIP 0.1 $\mu$ F 25V	
				C140	1-163-031-11	CERAMIC CHIP 0.01 $\mu$ F 50V	
				C143	1-126-391-11	ELECT CHIP 47 $\mu$ F 20% 6.3V	
				C145	1-163-031-11	CERAMIC CHIP 0.01 $\mu$ F 50V	

REF NO.	PART NO.	DESCRIPTION	REMARK	REF NO.	PART NO.	DESCRIPTION	REMARK
C149	1-163-059-91	CERAMIC CHIP	0.01μ F 10% 50V	IC102	8-759-100-96	IC μ PC4558G2	
C150	1-126-391-11	ELECT CHIP	47μ F 20% 6.3V	IC103	8-759-100-96	IC μ PC4558G2	
C151	1-163-009-11	CERAMIC CHIP	0.001μ F 10% 50V	IC105	8-752-065-79	IC CXA1470AM-T6	
C155	1-163-038-91	CERAMIC CHIP	0.1μ F 25V	IC106	8-759-988-13	IC LM393PS	
C156	1-163-031-11	CERAMIC CHIP	0.01μ F 50V	IC108	8-752-066-34	IC CXA1726M-T6	
C157	1-163-038-91	CERAMIC CHIP	0.1μ F 25V	IC111	8-759-100-96	IC μ PC4558G2	
C158	1-163-031-11	CERAMIC CHIP	0.01μ F 50V	IC112	8-759-158-86	IC CXA8021M-T6	
C159	1-163-031-11	CERAMIC CHIP	0.01μ F 50V	IC113	8-759-988-13	IC LM393PS	
C160	1-163-009-11	CERAMIC CHIP	0.001μ F 10% 50V	IC114	8-759-100-96	IC μ PC4558G2	
C161	1-163-009-11	CERAMIC CHIP	0.001μ F 10% 50V	IC115	8-759-158-86	IC CXA8021M-T6	
C162	1-163-031-11	CERAMIC CHIP	0.01μ F 50V	IC118	8-759-326-65	IC MP7670AS-TE2	
C163	1-163-031-11	CERAMIC CHIP	0.01μ F 50V	IC119	8-759-981-48	IC TL082M	
C164	1-163-031-11	CERAMIC CHIP	0.01μ F 50V	IC120	8-759-929-26	IC TL431CPS	
C167	1-163-059-91	CERAMIC CHIP	0.01μ F 10% 50V	IC203	8-759-100-96	IC μ PC4558G2	
C168	1-163-031-11	CERAMIC CHIP	0.01μ F 50V	IC301	8-752-066-34	IC CXA1726M-T6	
C169	1-163-031-11	CERAMIC CHIP	0.01μ F 50V			< TRANSISTOR >	
C175	1-163-031-11	CERAMIC CHIP	0.01μ F 50V				
C177	1-163-031-11	CERAMIC CHIP	0.01μ F 50V	Q101	8-729-216-22	TRANSISTOR 2SA1162-G	
C178	1-163-227-11	CERAMIC CHIP	10pF 0.5pF 50V	Q102	8-729-216-22	TRANSISTOR 2SA1162-G	
C179	1-104-559-11	FILM CHIP	0.047μ F 5% 16V	Q601	8-729-216-22	TRANSISTOR 2SA1162-G	
C180	1-163-059-91	CERAMIC CHIP	0.01μ F 10% 50V	Q602	8-729-216-22	TRANSISTOR 2SA1162-G	
C181	1-163-031-11	CERAMIC CHIP	0.01μ F 50V	Q603	8-729-216-22	TRANSISTOR 2SA1162-G	
C201	1-104-555-11	FILM CHIP	0.022μ F 5% 16V	Q604	8-729-116-05	TRANSISTOR 2SK160-K5	
C501	1-163-227-11	CERAMIC CHIP	10pF 0.5pF 50V			< RESISTOR >	
C502	1-163-009-11	CERAMIC CHIP	0.001μ F 10% 50V	R101	1-216-025-91	METAL GLAZE 100 5% 1/10W	
C602	1-163-031-11	CERAMIC CHIP	0.01μ F 50V	R102	1-216-097-91	METAL GLAZE 100K 5% 1/10W	
C603	1-163-059-91	CERAMIC CHIP	0.01μ F 10% 50V	R103	1-216-025-91	METAL GLAZE 100 5% 1/10W	
C612	1-163-038-91	CERAMIC CHIP	0.1μ F 25V	R104	1-216-025-91	METAL GLAZE 100 5% 1/10W	
C613	1-163-038-91	CERAMIC CHIP	0.1μ F 25V	R105	1-216-025-91	METAL GLAZE 100 5% 1/10W	
C614	1-163-038-91	CERAMIC CHIP	0.1μ F 25V	R106	1-216-025-91	METAL GLAZE 100 5% 1/10W	
C615	1-163-038-91	CERAMIC CHIP	0.1μ F 25V	R107	1-216-073-00	METAL GLAZE 10K 5% 1/10W	
C616	1-163-222-11	CERAMIC CHIP	5pF 0.25pF 50V	R108	1-216-097-91	METAL GLAZE 100K 5% 1/10W	
C622	1-163-275-11	CERAMIC CHIP	0.001μ F 5% 50V	R109	1-216-025-91	METAL GLAZE 100 5% 1/10W	
C623	1-126-391-11	ELECT CHIP	47μ F 20% 6.3V	R110	1-216-097-91	METAL GLAZE 100K 5% 1/10W	
C624	1-163-031-11	CERAMIC CHIP	0.01μ F 50V	R111	1-216-097-91	METAL GLAZE 100K 5% 1/10W	
C625	1-163-031-11	CERAMIC CHIP	0.01μ F 50V	R112	1-216-089-91	METAL GLAZE 47K 5% 1/10W	
C721	1-163-031-11	CERAMIC CHIP	0.01μ F 50V	R113	1-216-097-91	METAL GLAZE 100K 5% 1/10W	
C722	1-163-031-11	CERAMIC CHIP	0.01μ F 50V	R114	1-208-822-11	METAL CHIP 47K 0.50% 1/10W	
C724	1-163-038-91	CERAMIC CHIP	0.1μ F 25V	R115	1-216-671-11	METAL CHIP 6.8K 0.50% 1/10W	
C725	1-163-038-91	CERAMIC CHIP	0.1μ F 25V	R116	1-208-806-11	METAL CHIP 10K 0.50% 1/10W	
C801	1-163-009-11	CERAMIC CHIP	0.001μ F 10% 50V	R117	1-216-025-91	METAL GLAZE 100 5% 1/10W	
C802	1-163-038-91	CERAMIC CHIP	0.1μ F 25V	R118	1-216-025-91	METAL GLAZE 100 5% 1/10W	
C803	1-163-009-11	CERAMIC CHIP	0.001μ F 10% 50V	R119	1-216-097-91	METAL GLAZE 100K 5% 1/10W	
C821	1-163-222-11	CERAMIC CHIP	5pF 0.25pF 50V	R120	1-216-685-11	METAL CHIP 27K 0.50% 1/10W	
C822	1-162-638-11	CERAMIC CHIP	1μ F 16V	R123	1-216-049-91	METAL GLAZE 1K 5% 1/10W	
C861	1-163-031-11	CERAMIC CHIP	0.01μ F 50V	R124	1-216-049-91	METAL GLAZE 1K 5% 1/10W	
C862	1-163-031-11	CERAMIC CHIP	0.01μ F 50V	R127	1-208-822-11	METAL CHIP 47K 0.50% 1/10W	
		< CONNECTOR >		R129	1-216-699-11	METAL CHIP 100K 0.50% 1/10W	
CN101	1-774-415-11	CONNECTOR, BOARD TO BOARD 20P		R130	1-208-812-11	METAL CHIP 18K 0.50% 1/10W	
CN102	1-774-415-11	CONNECTOR, BOARD TO BOARD 20P		R132	1-208-823-11	METAL CHIP 51K 0.50% 1/10W	
		< IC >		R133	1-216-663-11	METAL CHIP 3.3K 0.50% 1/10W	
IC101	8-759-981-48	IC TL082M		R134	1-216-659-11	METAL CHIP 2.2K 0.50% 1/10W	
				R136	1-208-812-11	METAL CHIP 18K 0.50% 1/10W	



REF NO.	PART NO.	DESCRIPTION	REMARK	REF NO.	PART NO.	DESCRIPTION	REMARK
R141	1-216-065-00	METAL GLAZE	4.7K 5% 1/10W	R637	1-216-073-00	METAL GLAZE	10K 5% 1/10W
R151	1-208-800-11	METAL CHIP	5.6K 0.50% 1/10W	R638	1-216-689-11	METAL CHIP	39K 0.50% 1/10W
R152	1-208-806-11	METAL CHIP	10K 0.50% 1/10W	R639	1-216-089-91	METAL GLAZE	47K 5% 1/10W
R153	1-208-822-11	METAL CHIP	47K 0.50% 1/10W	R801	1-208-814-11	METAL CHIP	22K 0.50% 1/10W
R154	1-208-814-11	METAL CHIP	22K 0.50% 1/10W	R802	1-216-667-11	METAL CHIP	4.7K 0.50% 1/10W
R158	1-208-806-11	METAL CHIP	10K 0.50% 1/10W	R803	1-208-814-11	METAL CHIP	22K 0.50% 1/10W
R159	1-216-677-11	METAL CHIP	12K 0.50% 1/10W	R804	1-208-814-11	METAL CHIP	22K 0.50% 1/10W
R160	1-208-806-11	METAL CHIP	10K 0.50% 1/10W	R805	1-208-814-11	METAL CHIP	22K 0.50% 1/10W
R163	1-216-587-11	METAL CHIP	33K 0.50% 1/10W	R806	1-208-814-11	METAL CHIP	22K 0.50% 1/10W
R166	1-208-806-11	METAL CHIP	10K 0.50% 1/10W	R807	1-208-814-11	METAL CHIP	22K 0.50% 1/10W
R167	1-208-806-11	METAL CHIP	10K 0.50% 1/10W	R808	1-208-814-11	METAL CHIP	22K 0.50% 1/10W
R170	1-208-814-11	METAL CHIP	22K 0.50% 1/10W	R821	1-208-814-11	METAL CHIP	22K 0.50% 1/10W
R171	1-208-806-11	METAL CHIP	10K 0.50% 1/10W	R822	1-208-814-11	METAL CHIP	22K 0.50% 1/10W
R172	1-208-806-11	METAL CHIP	10K 0.50% 1/10W	R823	1-208-814-11	METAL CHIP	22K 0.50% 1/10W
R173	1-208-806-11	METAL CHIP	10K 0.50% 1/10W	R824	1-208-806-11	METAL CHIP	10K 0.50% 1/10W
R174	1-216-065-00	METAL GLAZE	4.7K 5% 1/10W	R825	1-216-665-11	METAL CHIP	3.9K 0.50% 1/10W
R175	1-208-814-11	METAL CHIP	22K 0.50% 1/10W	R826	1-216-089-91	METAL GLAZE	47K 5% 1/10W
R176	1-208-806-11	METAL CHIP	10K 0.50% 1/10W	R827	1-216-073-00	METAL GLAZE	10K 5% 1/10W
R177	1-208-814-11	METAL CHIP	22K 0.50% 1/10W	R828	1-216-025-91	METAL GLAZE	100 5% 1/10W
R196	1-216-025-91	METAL GLAZE	100 5% 1/10W	R829	1-208-814-11	METAL CHIP	22K 0.50% 1/10W
R197	1-208-814-11	METAL CHIP	22K 0.50% 1/10W	R830	1-208-814-11	METAL CHIP	22K 0.50% 1/10W
R198	1-208-814-11	METAL CHIP	22K 0.50% 1/10W	R831	1-208-806-11	METAL CHIP	10K 0.50% 1/10W
R201	1-208-799-11	METAL CHIP	5.1K 0.50% 1/10W	R832	1-216-667-11	METAL CHIP	4.7K 0.50% 1/10W
R202	1-208-814-11	METAL CHIP	22K 0.50% 1/10W	R833	1-216-699-11	METAL CHIP	100K 0.50% 1/10W
R205	1-216-025-91	METAL GLAZE	100 5% 1/10W	R834	1-208-822-11	METAL CHIP	47K 0.50% 1/10W
R206	1-216-025-91	METAL GLAZE	100 5% 1/10W	R835	1-208-822-11	METAL CHIP	47K 0.50% 1/10W
R207	1-216-025-91	METAL GLAZE	100 5% 1/10W	R861	1-208-806-11	METAL CHIP	10K 0.50% 1/10W
R208	1-216-025-91	METAL GLAZE	100 5% 1/10W	R862	1-208-806-11	METAL CHIP	10K 0.50% 1/10W
R209	1-216-025-91	METAL GLAZE	100 5% 1/10W	R863	1-208-806-11	METAL CHIP	10K 0.50% 1/10W
R210	1-216-079-00	METAL GLAZE	18K 5% 1/10W	R864	1-216-121-91	METAL GLAZE	1M 5% 1/10W
R211	1-216-025-91	METAL GLAZE	100 5% 1/10W	R865	1-216-065-00	METAL GLAZE	4.7K 5% 1/10W
R213	1-216-025-91	METAL GLAZE	100 5% 1/10W	R866	1-216-049-91	METAL GLAZE	1K 5% 1/10W
R501	1-216-121-91	METAL GLAZE	1M 5% 1/10W	R867	1-208-824-11	METAL CHIP	56K 0.50% 1/10W
R615	1-208-806-11	METAL CHIP	10K 0.50% 1/10W	R868	1-208-806-11	METAL CHIP	10K 0.50% 1/10W
R616	1-208-806-11	METAL CHIP	10K 0.50% 1/10W	R869	1-216-677-11	METAL CHIP	12K 0.50% 1/10W
R617	1-208-806-11	METAL CHIP	10K 0.50% 1/10W	R870	1-216-049-91	METAL GLAZE	1K 5% 1/10W
R618	1-208-806-11	METAL CHIP	10K 0.50% 1/10W	*****			
R619	1-216-661-11	METAL CHIP	2.7K 0.50% 1/10W	* A-1346-357-B	COMPLETE PCB, E (include D mounted) (14E1E/14E1U/14E5E/14E5U/ 14F1E/14F1U/14F5E/14F5U) *****		
R620	1-208-806-11	METAL CHIP	10K 0.50% 1/10W	* A-1346-356-A	COMPLETE PCB, E (include D mounted) (20E1E/20E1U/20F1E/20F1U) *****		
R621	1-208-806-11	METAL CHIP	10K 0.50% 1/10W	* X-4033-108-1	HEATSINK (DEFLECTION) ASSY		
R622	1-216-663-11	METAL CHIP	3.3K 0.50% 1/10W	* 3-648-057-00	NUT (ISO-4), u		
R623	1-216-049-91	METAL GLAZE	1K 5% 1/10W	* 4-050-794-01	INSULATOR		
R624	1-216-049-91	METAL GLAZE	1K 5% 1/10W	* 4-050-814-01	SHIELD, PCB		
R625	1-216-049-91	METAL GLAZE	1K 5% 1/10W	4-051-217-01	SHEET, RADIATION		
R626	1-216-049-91	METAL GLAZE	1K 5% 1/10W	* 4-053-101-01	SPACER, DY CONNECTOR		
R628	1-216-025-91	METAL GLAZE	100 5% 1/10W	* 4-381-905-01	SPRING (D)		
R629	1-208-806-11	METAL CHIP	10K 0.50% 1/10W	* 4-381-905-01	SPRING (D) (20E1E/20E1U/20F1E/20F1U)		
R630	1-216-033-00	METAL GLAZE	220 5% 1/10W	4-382-854-01	SCREW (M3X8), P, SW (+)		
R631	1-216-025-91	METAL GLAZE	100 5% 1/10W	4-382-854-01	SCREW (M3X8), P, SW (+)		
R632	1-216-025-91	METAL GLAZE	100 5% 1/10W				
R633	1-216-025-91	METAL GLAZE	100 5% 1/10W				
R634	1-216-025-91	METAL GLAZE	100 5% 1/10W				
R635	1-216-025-91	METAL GLAZE	100 5% 1/10W				
R636	1-216-089-91	METAL GLAZE	47K 5% 1/10W				

REF NO.	PART NO.	DESCRIPTION	REMARK	REF NO.	PART NO.	DESCRIPTION	REMARK
	4-382-854-01	SCREW (M3X8), P, SW (+)		C307	1-107-909-11	ELECT	47μ F 20% 50V (20E1E/20E1U/20F1E/20F1U)
	4-382-854-01	SCREW (M3X8), P, SW (+)		C308	1-102-114-00	CERAMIC	470pF 10% 50V (20E1E/20E1U/20F1E/20F1U)
	4-382-854-01	SCREW (M3X8), P, SW (+)		C309	1-128-526-11	ELECT	100μ F 20% 16V (20E1E/20E1U/20F1E/20F1U)
	4-382-854-01	SCREW (M3X8), P, SW (+)		C310	1-102-114-00	CERAMIC	470pF 10% 50V (20E1E/20E1U/20F1E/20F1U)
	*4-403-012-01	SPRING, STOPPER		C311	1-128-526-11	ELECT	100μ F 20% 16V (20E1E/20E1U/20F1E/20F1U)
	7-322-065-19	RUBBER, SILCON RIV (KE490W)		C312	1-164-161-11	CERAMIC CHIP	0.0022μ F 10% 50V (20E1E/20E1U/20F1E/20F1U)
		(14E1E/14E1U/14E5E/14E5U/14F1E/14F1U/14F5E/14F5U)		C401	1-136-165-00	FILM	0.1μ F 5% 50V (20E1E/20E1U/20F1E/20F1U)
	7-682-566-04	SCREW +B 4X20		C402	1-137-370-11	FILM	0.01μ F 5% 50V (20E1E/20E1U/20F1E/20F1U)
	7-685-871-01	SCREW +BVTT 3X6 (S)		C403	1-164-004-11	CERAMIC CHIP	0.1μ F 10% 25 (20E1E/20E1U/20F1E/20F1U)
		< CAPACITOR >		C405	1-128-526-11	ELECT	100μ F 20% 25V (20E1E/20E1U/20F1E/20F1U)
C25	1-162-115-00	CERAMIC	330pF 10% 2KV	C408	1-137-370-11	FILM	0.01μ F 5% 50V (20E1E/20E1U/20F1E/20F1U)
C26	1-137-350-11	FILM	0.015μ F 5% 100V	C409	1-136-165-00	FILM	0.1μ F 5% 50V (20E1E/20E1U/20F1E/20F1U)
C27	1-163-614-11	CERAMIC CHIP	220pF 5% 50V	C410	1-128-526-11	ELECT	100μ F 20% 25V (20E1E/20E1U/20F1E/20F1U)
C43	1-109-915-11	FILM	2.2μ F 3% 200V (20E1E/20E1U/20F1E/20F1U)	C503	1-163-031-11	CERAMIC CHIP	0.01μ F 50V
C43	1-104-494-11	FILM	3.9μ F 3% 200V (14E1E/14E1U/14E5E/14E5U/14F1E/14F1U/14F5E/14F5U)	C505	1-126-401-11	ELECT CHIP	1μ F 20% 50V
C44	1-109-915-11	FILM	2.2μ F 3% 200V (20E1E/20E1U/20F1E/20F1U)	C506	1-164-346-11	CERAMIC CHIP	1μ F 16V
C44	1-104-496-11	FILM	3.3μ F 3% 200V (14E1E/14E1U/14E5E/14E5U/14F1E/14F1U/14F5E/14F5U)	C507	1-126-398-11	ELECT CHIP	4.7μ F 20% 35V
C45	1-109-921-11	CERAMIC	0.0015μ F 10% 500V (20E1E/20E1U/20F1E/20F1U)	C530	1-106-367-00	MYLAR	0.01μ F 10% 100V
C45	1-102-002-00	CERAMIC	680pF 10% 500V (14E1E/14E1U/14E5E/14E5U/14F1E/14F1U/14F5E/14F5U)	C531	1-136-153-00	FILM	0.01μ F 5% 50V
C64	1-104-664-11	ELECT	47μ F 20% 25V	C601	1-136-157-00	FILM	0.022μ F 5% 50V
C65	1-110-641-51	ELECT	33μ F 20% 200V	C602	1-128-526-11	ELECT	100μ F 20% 25V
C66	1-126-600-11	ELECT	100μ F 20% 160V	C603	1-107-910-11	ELECT	100μ F 20% 35V
C001	1-136-165-00	FILM	0.1μ F 5% 50V	C604	1-128-526-11	ELECT	100μ F 20% 50V
C002	1-163-117-00	CERAMIC CHIP	100pF 5% 50V	C605	1-106-228-00	MYLAR	0.22μ F 10% 100V
C003	1-102-030-00	CERAMIC	330pF 10% 500V	C701	1-163-031-11	CERAMIC CHIP	0.01μ F 50V
C004	1-107-943-11	ELECT	10μ F 20% 160V	C702	1-126-396-11	ELECT CHIP	47μ F 20% 16V
C008	1-161-753-00	CERAMIC	470pF 10% 3KV	C703	1-137-502-11	FILM CHIP	0.1μ F 5% 25V
C101	1-128-526-11	ELECT	100μ F 20% 25V	C705	1-126-394-11	ELECT CHIP	10μ F 20% 16V
C102	1-128-526-11	ELECT	100μ F 20% 25V	C706	1-163-117-00	CERAMIC CHIP	100pF 5% 50V
C103	1-101-004-00	CERAMIC	0.01μ F 50V	C707	1-126-401-11	ELECT CHIP	1μ F 20% 50V
C104	1-101-004-00	CERAMIC	0.01μ F 50V	C708	1-164-695-11	CERAMIC	0.0022μ F 5% 50V
C151	1-163-141-00	CERAMIC CHIP	0.001μ F 5% 50V	C709	1-126-405-11	ELECT CHIP	10μ F 20% 50V
C152	1-101-880-00	CERAMIC	47pF 5% 50V	C710	1-126-396-11	ELECT CHIP	47μ F 20% 16V
C155	1-163-133-00	CERAMIC CHIP	470pF 5% 50V	C711	1-163-038-91	CERAMIC CHIP	0.1μ F 25V
C156	1-102-074-00	CERAMIC	0.001μ F 10% 50V	C801	1-136-165-00	FILM	0.1μ F 5% 50V
C159	1-163-031-11	CERAMIC CHIP	0.01μ F 50V	C802	1-128-526-11	ELECT	100μ F 20% 16V
C160	1-136-165-00	FILM	0.1μ F 5% 50V	C803	1-128-526-11	ELECT	100μ F 20% 16V
C301	1-163-141-00	CERAMIC CHIP	100pF 5% 50V (20E1E/20E1U/20F1E/20F1U)	C804	1-136-165-00	FILM	0.1μ F 5% 50V
C302	1-163-129-00	CERAMIC CHIP	330pF 5% 50V (20E1E/20E1U/20F1E/20F1U)	C805	1-137-370-11	FILM	0.01μ F 5% 50V
C303	1-104-664-11	ELECT	47μ F 20% 25V (20E1E/20E1U/20F1E/20F1U)	C806	1-137-370-11	FILM	0.01μ F 5% 50V
C304	1-107-909-11	ELECT	47μ F 20% 50V (20E1E/20E1U/20F1E/20F1U)	C807	1-164-004-11	CERAMIC CHIP	0.1μ F 10% 25V
C305	1-107-909-11	ELECT	47μ F 20% 50V (20E1E/20E1U/20F1E/20F1U)	C1001	1-128-527-11	ELECT	330μ F 20% 25V
C306	1-107-909-11	ELECT	47μ F 20% 50V (20E1E/20E1U/20F1E/20F1U)				

E

REF NO.	PART NO.	DESCRIPTION	REMARK	REF NO.	PART NO.	DESCRIPTION	REMARK
C1002	1-128-528-11	ELECT	470μ F 20% 16V	C5102	1-163-031-11	CERAMIC CHIP	0.01μ F 50V
C1003	1-128-527-11	ELECT	330μ F 20% 25V	C5103	1-163-031-11	CERAMIC CHIP	0.01μ F 50V
C1004	1-128-528-11	ELECT	470μ F 20% 16V	C5104	1-128-526-11	ELECT	100μ F 20% 25V
C1005	1-104-652-11	ELECT	470μ F 20% 10V	C5105	1-128-526-11	ELECT	100μ F 20% 25V
C1006	1-104-652-11	ELECT	470μ F 20% 10V	C5201	1-136-081-00	FILM	0.012μ F 3% 2KV
C1007	1-104-652-11	ELECT	470μ F 20% 10V	C7001	1-163-031-11	CERAMIC CHIP	0.01μ F 50V
C1008	1-104-652-11	ELECT	470μ F 20% 10V	C7002	1-163-031-11	CERAMIC CHIP	0.01μ F 50V
C1009	1-107-492-11	ELECT	47μ F 20% 160V	C7003	1-163-031-11	CERAMIC CHIP	0.01μ F 50V
C2001	1-163-031-11	CERAMIC CHIP	0.01μ F 50V	C7004	1-163-031-11	CERAMIC CHIP	0.01μ F 50V
C2002	1-163-037-11	CERAMIC CHIP	0.022μ F 10% 25V	C7005	1-163-031-11	CERAMIC CHIP	0.01μ F 50V
C2003	1-163-031-11	CERAMIC CHIP	0.01μ F 50V	C7006	1-163-031-11	CERAMIC CHIP	0.01μ F 50V
C2004	1-164-505-11	CERAMIC CHIP	2.2μ F 16V	C7007	1-163-031-11	CERAMIC CHIP	0.01μ F 50V
C2006	1-163-031-11	CERAMIC CHIP	0.01μ F 50V	C7008	1-126-392-11	ELECT CHIP	100μ F 20% 6.3V
C2007	1-163-031-11	CERAMIC CHIP	0.01μ F 50V			< CONNECTOR >	
C2008	1-163-031-11	CERAMIC CHIP	0.01μ F 50V	CN007	*1-580-798-11	CONNECTOR PIN (DY) 6P	
C2013	1-163-031-11	CERAMIC CHIP	0.01μ F 50V	CN101	1-774-414-11	CONNECTOR, BOARD TO BOARD 20P	
C2015	1-128-526-11	ELECT	100μ F 20% 16V	CN102	1-774-414-11	CONNECTOR, BOARD TO BOARD 20P	
C2016	1-164-756-11	CERAMIC	0.0033μ F 5% 50V	CN5000	1-774-523-11	PIN, CONNECTOR (PC BOARD) 64P	
C2017	1-107-890-11	ELECT	2200μ F 20% 25V	CN5003	1-774-523-11	PIN, CONNECTOR (PC BOARD) 64P	
C2018	1-104-664-11	ELECT	47μ F 20% 25V			< DIODE >	
C2019	1-104-553-11	FILM CHIP	0.015μ F 5% 16V	D1	8-719-971-20	DIODE ERC38-06	
C2023	1-163-125-00	CERAMIC CHIP	220pF 5% 50V	D2	8-719-300-76	DIODE RH-1A	
C2025	1-163-031-11	CERAMIC CHIP	0.01μ F 50V	D25	8-719-404-46	DIODE MA110	
C2027	1-136-173-00	FILM	0.47μ F 5% 50V	D55	8-719-500-42	DIODE D8LCA20R	
C2028	1-136-157-00	FILM	0.022μ F 5% 50V	D61	8-719-901-95	DIODE V19CSS	
C2029	1-163-031-11	CERAMIC CHIP	0.01μ F 50V	D101	8-719-971-20	DIODE ERC38-06	
C2030	1-163-023-00	CERAMIC CHIP	0.015μ F 10% 50V	D102	8-719-971-20	DIODE ERC38-06	
C2031	1-163-031-11	CERAMIC CHIP	0.01μ F 50V	D154	8-719-911-19	DIODE 1SS119-25	
C2033	1-104-664-11	ELECT	47μ F 20% 25V	D155	8-719-911-19	DIODE 1SS119-25	
C2039	1-163-031-11	CERAMIC CHIP	0.01μ F 50V	D301	8-719-971-20	DIODE ERC38-06 (20E1E/20E1U/20F1E/20F1U)	
C2041	1-104-551-11	FILM CHIP	0.01μ F 5% 16V	D302	8-719-971-20	DIODE ERC38-06 (20E1E/20E1U/20F1E/20F1U)	
C2042	1-163-031-11	CERAMIC CHIP	0.01μ F 50V	D401	8-719-911-19	DIODE 1SS119-25 (20E1E/20E1U/20F1E/20F1U)	
C2043	1-104-551-11	FILM CHIP	0.01μ F 5% 16V	D402	8-719-911-19	DIODE 1SS119-25 (20E1E/20E1U/20F1E/20F1U)	
C2044	1-163-031-11	CERAMIC CHIP	0.01μ F 50V	D502	8-719-404-46	DIODE MA110	
C2048	1-163-031-11	CERAMIC CHIP	0.01μ F 50V	D503	8-719-404-46	DIODE MA110	
C2049	1-163-031-11	CERAMIC CHIP	0.01μ F 50V	D505	8-719-404-46	DIODE MA110	
C2050	1-104-539-11	FILM CHIP	0.001μ F 5% 50V	D531	8-719-901-83	DIODE 1SS83	
C2051	1-163-031-11	CERAMIC CHIP	0.01μ F 50V	D532	8-719-911-19	DIODE 1SS119-25	
C2052	1-163-275-11	CERAMIC CHIP	0.001μ F 5% 50V	D551	8-719-106-70	DIODE RD12M-B1	
C2054	1-164-004-11	CERAMIC CHIP	0.1μ F 10% 25V	D606	8-719-979-85	DIODE EGP20G	
C2056	1-164-004-11	CERAMIC CHIP	0.1μ F 10% 25V	D607	8-719-979-85	DIODE EGP20G	
C2057	1-164-004-11	CERAMIC CHIP	0.1μ F 10% 25V	D701	8-719-404-46	DIODE MA110	
C2059	1-164-004-11	CERAMIC CHIP	0.1μ F 10% 25V	D702	8-719-105-45	DIODE RD3.3M-B1	
C2060	1-164-004-11	CERAMIC CHIP	0.1μ F 10% 25V	D2002	8-719-404-46	DIODE MA110	
C2061	1-163-275-11	CERAMIC CHIP	0.001μ F 5% 50V	D5001	8-719-404-46	DIODE MA110	
C2062	1-163-275-11	CERAMIC CHIP	0.001μ F 5% 50V	D5002	8-719-110-13	DIODE RD9.1ESB2	
C2063	1-163-031-11	CERAMIC CHIP	0.01μ F 50V	D7001	8-719-105-91	DIODE RD5.6M-B2	
C2065	1-163-031-11	CERAMIC CHIP	0.01μ F 50V	D7002	8-719-404-46	DIODE MA110	
C2066	1-163-125-00	CERAMIC CHIP	220pF 5% 50V			< FERRITE BEAD >	
C2067	1-163-145-00	CERAMIC	1500pF 5% 50V	FB2	1-410-396-41	FERRITE BEAD INDUCTOR 0.45μ H	
C2068	1-163-031-11	CERAMIC CHIP	0.01μ F 50V				
C2081	1-164-346-11	CERAMIC CHIP	1μ F 16V				
C5000	1-126-396-11	ELECT CHIP	47μ F 20% 16V				
C5005	1-106-383-00	MYLAR	0.047μ F 10% 200V				



REF NO.	PART NO.	DESCRIPTION	REMARK	REF NO.	PART NO.	DESCRIPTION	REMARK
		< FILTER >					
FL1002	1-239-183-11	FILTER, EMI		Q28	8-729-141-30	TRANSISTOR 2SC3623A-LK	
FL1006	1-236-164-11	ENCAPSULATED COMPONENT		Q51	8-729-015-28	TRANSISTOR IRFI9630GS	
FL1007	1-236-164-11	ENCAPSULATED COMPONENT		Q52	8-729-019-57	TRANSISTOR 2SA1208S-TP	
		< IC >		Q54	8-729-027-38	TRANSISTOR DTA144EKA-T146	
IC101	8-759-100-96	IC $\mu$ PC4558G2		Q55	8-729-027-59	TRANSISTOR DTC144EKA-T146	
IC301	8-749-924-04	IC STK390-120 (20E1E/20E1U/20F1E/20F1U)		Q56	8-729-027-38	TRANSISTOR DTA144EKA-T146	
IC401	8-759-822-38	IC LA6510 (20E1E/20E1U/20F1E/20F1U)		Q57	8-729-027-59	TRANSISTOR DTC144EKA-T146	
IC501	8-759-988-13	IC LM393PS		Q58	8-729-027-59	TRANSISTOR DTC144EKA-T146	
IC601	8-759-280-35	IC LA7845		Q101	8-729-017-06	TRANSISTOR 2SC4793	
IC701	8-759-346-56	IC FA5301N-TE1		Q102	8-729-385-82	TRANSISTOR 2SB858-C	
IC801	8-759-822-38	IC LA6510		Q103	8-729-119-76	TRANSISTOR 2SA1175-HFE	
IC1001	8-759-929-65	IC LM7912CT		Q104	8-729-800-32	TRANSISTOR 2SC2362K-G	
IC1002	8-759-231-58	IC TA7812S		Q105	8-729-800-32	TRANSISTOR 2SC2362K-G	
IC1003	8-759-144-82	IC $\mu$ PC2405HF		Q151	8-729-309-36	TRANSISTOR 2SA893A	
IC1004	8-759-247-67	IC LM2990T-5.0		Q152	8-729-309-36	TRANSISTOR 2SA893A	
IC2001	8-759-925-80	IC SN74HC14ANS		Q155	8-729-140-96	TRANSISTOR 2SD774-34	
IC2002	8-759-008-48	IC MC74HC86F		Q156	8-729-255-12	TRANSISTOR 2SC2551-O	
IC2003	8-759-032-01	IC MC74HC00AF		Q157	8-729-309-36	TRANSISTOR 2SA893A-EV	
IC2007	8-759-191-50	IC TDA9102C		Q158	8-729-017-06	TRANSISTOR 2SC4793	
IC2011	8-759-988-13	IC LM393PS			4-393-406-01	SHEET (R), RADIATION (Q158)	
IC2012	8-759-008-45	IC MC74HC4538F		Q159	8-729-017-06	TRANSISTOR 2SC4793	
IC2015	8-759-100-96	IC $\mu$ PC4558G2			4-393-406-01	SHEET (R), RADIATION (Q159)	
IC2016	8-759-008-45	IC MC74HC4538F		Q501	8-729-027-59	TRANSISTOR DTC144EKA-T146	
IC2017	8-759-008-45	IC MC74HC4538F		Q502	8-729-027-59	TRANSISTOR DTC144EKA-T146	
IC2019	8-759-032-23	IC MC74HC74AF		Q505	8-729-027-59	TRANSISTOR DTC144EKA-T146	
IC2701	8-759-926-37	IC SN74HC193ANS		Q507	8-729-027-59	TRANSISTOR DTC144EKA-T146	
IC2702	8-759-926-37	IC SN74HC193ANS		Q701	8-729-120-28	TRANSISTOR 2SC1623-L5L6	
IC2703	8-759-926-37	IC SN74HC193ANS		Q702	8-729-216-22	TRANSISTOR 2SA1162-G	
IC2704	8-759-926-98	IC SN74HC4040ANS		Q2001	8-729-027-59	TRANSISTOR DTC144EKA-T146	
IC2705	8-759-013-92	IC MC74HC164F		Q2002	8-729-027-59	TRANSISTOR DTC144EKA-T146	
IC7001	8-759-346-47	IC MB89613R-236		Q2003	8-729-027-59	TRANSISTOR DTC144EKA-T146	
IC7002	8-759-032-26	IC MC74HC125AF		Q5000	8-729-027-59	TRANSISTOR DTC144EKA-T146	
IC7003	8-759-032-53	IC MC74HC244AF		Q7001	8-729-027-59	TRANSISTOR DTC144EKA-T146	
IC7004	8-759-156-54	IC X25040SI		Q7002	8-729-027-59	TRANSISTOR DTC144EKA-T146	
IC7005	8-759-064-36	IC MB88346BPFV		Q7003	8-729-027-59	TRANSISTOR DTC144EKA-T146	
		< COIL >				< RESISTOR >	
L41	1-411-667-11	COIL, HORIZONTAL LINEARITY (20E1E/20E1U/20F1E/20F1U)		R10	1-215-916-00	METAL OXIDE	680 5% 3W F
L41	1-411-668-11	COIL, HORIZONTAL LINEARITY (14E1E/14E1U/14E5E/14E5U/14F1E/14F1U/14F5E/14F5U)		R11	1-215-916-00	METAL OXIDE	680 5% 3W F
L50	1-459-433-00	COIL (WITH CORE)		R25	1-216-025-91	METAL GLAZE	100 5% 1/10W
L55	1-411-515-11	COIL, CHOKE 300mH		R26	1-216-051-00	METAL GLAZE	1.2K 5% 1/10W
L101	1-459-148-00	COIL		R27	1-216-025-91	METAL GLAZE	100 5% 1/10W
		< TRANSISTOR >		R28	1-216-057-00	METAL GLAZE	2.2K 5% 1/10W
Q1	8-729-119-80	TRANSISTOR 2SC2688-LK		R29	1-216-073-00	METAL GLAZE	10K 5% 1/10W
Q2	8-729-016-32	TRANSISTOR 2SC4927-01		R30	1-216-057-00	METAL GLAZE	2.2K 5% 1/10W
Q25	8-729-120-28	TRANSISTOR 2SC1623-L5L6		R31	1-216-097-91	METAL GLAZE	100K 5% 1/10W
Q26	8-729-216-22	TRANSISTOR 2SA1162-G		R45	1-215-913-11	METAL OXIDE	220 5% 3W F (20E1E/20E1U/20F1E/20F1U)
Q27	8-729-141-30	TRANSISTOR 2SC3623A-LK		R45	1-215-911-11	METAL OXIDE	100 5% 3W F (14E1E/14E1U/14E5E/14E5U/14F1E/14F1U/14F5E/14F5U)
				R51	1-216-393-00	METAL OXIDE	2.2 5% 2W F
				R62	1-215-455-00	METAL	27K 1% 1/4W
				R63	1-215-447-00	METAL	12K 1% 1/4W
				R67	1-249-425-11	CARBON	4.7K 5% 1/4W
				R68	1-247-883-00	CARBON	150K 5% 1/4W

REF NO.	PART NO.	DESCRIPTION	REMARK	REF NO.	PART NO.	DESCRIPTION	REMARK
R69	1-247-863-91	CARBON	22K 5% 1/4W	R401	1-249-414-11	CARBON	560 5% 1/4W F (20E1E/20E1U/20F1E/20F1U)
R70	1-216-369-00	METAL OXIDE	1 5% 2W F	R402	1-249-393-11	CARBON	10 5% 1/4W F (20E1E/20E1U/20F1E/20F1U)
R71	1-216-049-91	METAL GLAZE	1K 5% 1/10W	R403	1-249-377-11	CARBON	0.47 5% 1/4W F (20E1E/20E1U/20F1E/20F1U)
R72	1-216-049-91	METAL GLAZE	1K 5% 1/10W	R404	1-249-385-11	CARBON	2.2 5% 1/4W (20E1E/20E1U/20F1E/20F1U)
R73	1-216-049-91	METAL GLAZE	1K 5% 1/10W	R405	1-216-079-00	METAL GLAZE	18K 5% 1/10W (20E1E/20E1U/20F1E/20F1U)
R001	1-216-017-91	METAL GLAZE	47 5% 1/10W	R406	1-216-085-00	METAL GLAZE	33K 5% 1/10W (20E1E/20E1U/20F1E/20F1U)
R002	1-216-073-00	METAL GLAZE	10K 5% 1/10W	R407	1-216-101-00	METAL GLAZE	150K 5% 1/10W (20E1E/20E1U/20F1E/20F1U)
R003	1-216-025-91	METAL GLAZE	100 5% 1/10W	R408	1-208-806-11	METAL CHIP	10K 0.50% 1/10W (20E1E/20E1U/20F1E/20F1U)
R004	1-249-389-11	CARBON	4.7 5% 1/4W	R409	1-216-049-91	METAL GLAZE	1K 5% 1/10W (20E1E/20E1U/20F1E/20F1U)
R005	1-249-423-11	CARBON	3.3K 5% 1/4W	R411	1-216-671-11	METAL CHIP	6.8K 0.50% 1/10W (20E1E/20E1U/20F1E/20F1U)
R006	1-215-916-00	METAL OXIDE	680 5% 3W F	R412	1-208-806-11	METAL CHIP	10K 0.50% 1/10W (20E1E/20E1U/20F1E/20F1U)
R007	1-216-385-11	METAL OXIDE	0.47 5% 3W F	R413	1-216-667-11	METAL CHIP	4.7K 0.50% 1/10W (20E1E/20E1U/20F1E/20F1U)
R008	1-249-401-11	CARBON	47 5% 1/4W	R416	1-216-661-11	METAL CHIP	2.7K 0.50% 1/10W (20E1E/20E1U/20F1E/20F1U)
R101	1-215-889-00	METAL OXIDE	330 5% 2W F	R417	1-249-385-11	CARBON	2.2 5% 1/4W (20E1E/20E1U/20F1E/20F1U)
R102	1-249-474-11	CARBON	1 5% 1/2W F	R418	1-249-377-11	CARBON	0.47 5% 1/4W F (20E1E/20E1U/20F1E/20F1U)
R103	1-249-474-11	CARBON	1 5% 1/2W F	R419	1-249-407-11	CARBON	150 5% 1/4W F (20E1E/20E1U/20F1E/20F1U)
R104	1-215-437-00	CARBON	4.7K 5% 1/4W	R420	1-249-392-11	CARBON	8.2 5% 1/4W F (20E1E/20E1U/20F1E/20F1U)
R105	1-215-421-00	CARBON	1K 5% 1/4W	R421	1-249-393-11	CARBON	10 5% 1/4W (20E1E/20E1U/20F1E/20F1U)
R106	1-215-429-00	METAL	2.2K 1% 1/4W	R422	1-249-393-11	CARBON	10 5% 1/4W (20E1E/20E1U/20F1E/20F1U)
R107	1-216-671-11	METAL CHIP	6.8K 0.50% 1/10W	R505	1-216-073-00	METAL GLAZE	10K 5% 1/10W
R108	1-216-049-91	METAL GLAZE	1K 5% 1/10W	R506	1-216-073-00	METAL GLAZE	10K 5% 1/10W
R109	1-215-429-00	METAL	2.2K 1% 1/4W	R507	1-216-073-00	METAL GLAZE	10K 5% 1/10W
R110	1-216-671-11	METAL CHIP	6.8K 0.50% 1/10W	R508	1-216-121-91	METAL GLAZE	1M 5% 1/10W
R111	1-216-049-91	METAL GLAZE	1K 5% 1/10W	R512	1-216-089-91	METAL GLAZE	47K 5% 1/10W
R112	1-249-381-11	CARBON	1 5% 1/4W F	R513	1-216-105-91	METAL GLAZE	220K 5% 1/10W
R113	1-249-381-11	CARBON	1 5% 1/4W F	R514	1-216-073-00	METAL GLAZE	10K 5% 1/10W
R151	1-208-806-11	METAL CHIP	10K 0.50% 1/10W	R515	1-216-073-00	METAL GLAZE	10K 5% 1/10W
R152	1-216-295-91	CONDUCTOR, CHIP (2012)		R516	1-216-073-00	METAL GLAZE	10K 5% 1/10W
R153	1-249-418-11	CARBON	1.2K 5% 1/4W	R518	1-216-073-00	METAL GLAZE	10K 5% 1/10W
R154	1-249-421-11	CARBON	2.2K 5% 1/4W	R519	1-216-073-00	METAL GLAZE	10K 5% 1/10W
R157	1-249-422-11	CARBON	2.7K 5% 1/4W	R520	1-216-049-91	METAL GLAZE	1K 5% 1/10W
R158	1-215-431-00	METAL	2.7K 1% 1/4W	R521	1-216-097-91	METAL GLAZE	100K 5% 1/10W
R160	1-249-414-11	CARBON	560 5% 1/4W	R530	1-249-417-11	CARBON	1K 5% 1/4W
R161	1-215-453-00	METAL	22K 1% 1/4W	R532	1-247-883-00	CARBON	150K 5% 1/4W
R162	1-216-365-00	METAL OXIDE	0.47 5% 2W F	R533	1-216-105-91	METAL GLAZE	220K 5% 1/10W
R163	1-216-365-00	METAL OXIDE	0.47 5% 2W F	R551	1-216-699-11	METAL CHIP	100K 0.50% 1/10W
R165	1-216-385-11	METAL OXIDE	0.47 5% 3W F				
R301	1-216-651-11	METAL CHIP	1K 0.50% 1/10W (20E1E/20E1U/20F1E/20F1U)				
R302	1-208-806-11	METAL CHIP	10K 0.50% 1/10W (20E1E/20E1U/20F1E/20F1U)				
R303	1-216-025-91	METAL GLAZE	100 5% 1/10W (20E1E/20E1U/20F1E/20F1U)				
R304	1-208-806-11	METAL CHIP	4.7K 0.50% 1/10W (20E1E/20E1U/20F1E/20F1U)				
R305	1-215-863-11	METAL OXIDE	100 5% 1W F (20E1E/20E1U/20F1E/20F1U)				
R306	1-215-863-11	METAL OXIDE	100 5% 1W F (20E1E/20E1U/20F1E/20F1U)				
R307	1-216-426-11	METAL OXIDE	82 5% 1W F (20E1E/20E1U/20F1E/20F1U)				
R308	1-216-349-00	METAL OXIDE	1 5% 1W F (20E1E/20E1U/20F1E/20F1U)				
R309	1-216-065-00	METAL GLAZE	4.7K 5% 1/10W (20E1E/20E1U/20F1E/20F1U)				



REF NO.	PART NO.	DESCRIPTION	REMARK	REF NO.	PART NO.	DESCRIPTION	REMARK
R552	1-208-806-11	METAL CHIP	10K 0.50% 1/10W	R807	1-249-401-11	CARBON	47 5% 1/4W F (20E1E/20E1U/20F1E/20F1U)
R553	1-216-673-11	METAL CHIP	8.2K 0.50% 1/10W	R807	1-249-392-11	CARBON	8.2 5% 1/4W F (14E1E/14E1U/14E5E/14E5U/14F1E/14F1U/14F5E/14F5U)
R601	1-216-676-11	METAL CHIP	11K 0.50% 1/10W (20E1E/20E1U/20F1E/20F1U)	R808	1-249-393-11	CARBON	10 5% 1/4W
R601	1-216-674-11	METAL CHIP	9.1K 0.50% 1/10W (14E1E/14E1U/14E5E/14E5U/14F1E/14F1U/14F5E/14F5U)	R809	1-249-377-11	CARBON	0.47 5% 1/4W F
R602	1-215-431-00	METAL	2.7K 1% 1/4W	R810	1-249-425-11	CARBON	4.7K 5% 1/4W F (20E1E/20E1U/20F1E/20F1U)
R603	1-249-411-11	CARBON	330 5% 1/4W F (20E1E/20E1U/20F1E/20F1U)	R810	1-249-418-11	CARBON	1.2K 5% 1/4W F (14E1E/14E1U/14E5E/14E5U/14F1E/14F1U/14F5E/14F5U)
R603	1-216-432-00	METAL OXIDE	820 5% 1W F (14E1E/14E1U/14E5E/14E5U/14F1E/14F1U/14F5E/14F5U)	R811	1-249-392-11	CARBON	8.2 5% 1/4W F (20E1E/20E1U/20F1E/20F1U)
R605	1-249-377-11	CARBON	0.47 5% 1/4W F	R811	1-249-385-11	CARBON	2.2 5% 1/4W F (14E1E/14E1U/14E5E/14E5U/14F1E/14F1U/14F5E/14F5U)
R606	1-214-799-11	METAL OXIDE	2 5% 1W F (20E1E/20E1U/20F1E/20F1U)	R812	1-216-057-00	METAL GLAZE	2.2K 5% 1/10W (20E1E/20E1U/20F1E/20F1U)
R606	1-214-807-55	METAL OXIDE	4.3 1% 1/2W (14E1E/14E1U/14E5E/14E5U/14F1E/14F1U/14F5E/14F5U)	R812	1-216-051-00	METAL GLAZE	1.2K 5% 1/10W (14E1E/14E1U/14E5E/14E5U/14F1E/14F1U/14F5E/14F5U)
R608	1-249-383-11	CARBON	1.5 5% 1/4W F	R813	1-249-385-11	CARBON	2.2 5% 1/4W
R610	1-216-659-11	METAL CHIP	2.2K 0.50% 1/10W	R814	1-249-393-11	CARBON	10 5% 1/4W
R611	1-249-377-11	CARBON	0.47 5% 1/4W F	R815	1-216-089-91	METAL GLAZE	47K 5% 1/10W
R612	1-249-377-11	CARBON	0.47 5% 1/4W F	R816	1-249-385-11	CARBON	2.2 5% 1/4W
R613	1-214-799-11	METAL	2 1% 1/2W (20E1E/20E1U/20F1E/20F1U)	R817	1-216-073-00	METAL GLAZE	10K 5% 1/10W
R613	1-214-807-55	METAL	4.3 1% 1/2W F (14E1E/14E1U/14E5E/14E5U/14F1E/14F1U/14F5E/14F5U)	R818	1-216-055-00	METAL GLAZE	1.8K 5% 1/10W (20E1E/20E1U/20F1E/20F1U)
R700	1-216-041-00	METAL GLAZE	470 5% 1/10W	R818	1-216-047-91	METAL GLAZE	820 5% 1/10W (14E1E/14E1U/14E5E/14E5U/14F1E/14F1U/14F5E/14F5U)
R701	1-208-806-11	METAL CHIP	22K 0.50% 1/10W	R819	1-216-049-91	METAL GLAZE	1K 5% 1/10W
R702	1-216-667-11	METAL CHIP	4.7K 0.50% 1/10W (20E1E/20E1U/20F1E/20F1U)	R2001	1-216-097-91	METAL GLAZE	100K 5% 1/10W
R702	1-216-671-11	METAL CHIP	6.8K 0.50% 1/10W (14E1E/14E1U/14E5E/14E5U/14F1E/14F1U/14F5E/14F5U)	R2010	1-216-695-11	METAL CHIP	68K 0.50% 1/10W
R703	1-208-800-11	METAL CHIP	5.6K 0.50% 1/10W	R2011	1-208-801-11	METAL CHIP	6.2K 0.50% 1/10W
R704	1-216-093-11	METAL GLAZE	68K 5% 1/10W	R2012	1-208-822-11	METAL CHIP	47K 0.50% 1/10W
R705	1-216-663-11	METAL CHIP	3.3K 0.50% 1/10W	R2013	1-216-641-11	METAL CHIP	390 0.50% 1/10W
R706	1-216-665-11	METAL CHIP	3.9K 0.50% 1/10W	R2014	1-216-049-91	METAL GLAZE	1K 5% 1/10W
R707	1-216-073-00	METAL GLAZE	10K 5% 1/10W	R2015	1-216-073-00	METAL GLAZE	10K 5% 1/10W
R708	1-216-049-91	METAL GLAZE	1K 5% 1/10W	R2016	1-216-049-91	METAL GLAZE	1K 5% 1/10W
R709	1-216-685-11	METAL CHIP	27K 0.5% 1/10W	R2017	1-216-065-00	METAL GLAZE	4.7K 5% 1/10W
R710	1-216-083-00	METAL GLAZE	27K 5% 1/10W	R2018	1-216-689-11	METAL CHIP	39K 0.50% 1/10W
R711	1-216-069-00	METAL GLAZE	6.8K 5% 1/10W	R2019	1-216-697-91	METAL CHIP	82K 0.50% 1/10W
R712	1-216-073-00	METAL GLAZE	10K 5% 1/10W	R2020	1-216-045-91	METAL GLAZE	1K 5% 1/10W
R713	1-216-073-00	METAL GLAZE	10K 5% 1/10W	R2021	1-208-806-11	METAL CHIP	10K 0.50% 1/10W
R802	1-216-663-11	METAL CHIP	3.3K 0.50% 1/10W (20E1E/20E1U/20F1E/20F1U)	R2022	1-208-806-11	METAL CHIP	10K 0.50% 1/10W
R802	1-216-657-11	METAL CHIP	1.8K 0.50% 1/10W (14E1E/14E1U/14E5E/14E5U/14F1E/14F1U/14F5E/14F5U)	R2023	1-208-806-11	METAL CHIP	10K 0.50% 1/10W
R803	1-208-806-11	METAL CHIP	10K 0.50% 1/10W	R2024	1-208-806-11	METAL CHIP	10K 0.50% 1/10W
R804	1-216-667-11	METAL CHIP	4.7K 0.50% 1/10W (20E1E/20E1U/20F1E/20F1U)	R2025	1-216-049-91	METAL GLAZE	1K 5% 1/10W
R804	1-216-659-11	METAL CHIP	2.2K 0.50% 1/10W (14E1E/14E1U/14E5E/14E5U/14F1E/14F1U/14F5E/14F5U)	R2026	1-216-097-91	METAL GLAZE	100K 5% 1/10W
R805	1-249-377-11	CARBON	0.47 5% 1/4W F	R2027	1-216-699-91	METAL CHIP	100K 0.50% 1/10W
R806	1-249-433-11	CARBON	22K 5% 1/4W F (20E1E/20E1U/20F1E/20F1U)	R2028	1-218-766-11	METAL CHIP	390K 0.50% 1/10W
R806	1-249-424-11	CARBON	3.9K 5% 1/4W F (14E1E/14E1U/14E5E/14E5U/14F1E/14F1U/14F5E/14F5U)	R2029	1-216-097-91	METAL GLAZE	100K 5% 1/10W
				R2030	1-216-041-00	METAL GLAZE	470 5% 1/10W
				R2032	1-216-695-11	METAL CHIP	68K 0.50% 1/10W
				R2033	1-218-754-11	METAL CHIP	120K 0.50% 1/10W
				R2035	1-216-687-11	METAL CHIP	33K 0.50% 1/10W
				R2036	1-216-025-91	METAL GLAZE	100 5% 1/10W
				R2037	1-216-073-00	METAL GLAZE	10K 5% 1/10W

E

REF NO.	PART NO.	DESCRIPTION	REMARK	REF NO.	PART NO.	DESCRIPTION	REMARK
R2038	1-208-806-11	METAL CHIP	10K 0.50% 1/10W	R6577	1-216-025-91	METAL GLAZE	100 5% 1/10W
R2039	1-208-824-11	METAL CHIP	56K 0.50% 1/10W	R6578	1-216-025-91	METAL GLAZE	100 5% 1/10W
R2040	1-216-049-91	METAL GLAZE	1K 5% 1/10W	R6579	1-216-025-91	METAL GLAZE	100 5% 1/10W
R2041	1-216-049-91	METAL GLAZE	1K 5% 1/10W	R6580	1-216-025-91	METAL GLAZE	100 5% 1/10W
R2043	1-216-049-91	METAL GLAZE	1K 5% 1/10W	R6581	1-216-025-91	METAL GLAZE	100 5% 1/10W
R2044	1-208-806-11	METAL CHIP	10K 0.50% 1/10W	R7001	1-216-097-91	METAL GLAZE	100K 5% 1/10W
R2045	1-216-057-00	METAL GLAZE	2.2K 5% 1/10W	R7002	1-216-097-91	METAL GLAZE	100K 5% 1/10W
R2046	1-216-684-91	METAL CHIP	24K 0.50% 1/10W	R7003	1-216-097-91	METAL GLAZE	100K 5% 1/10W
R2047	1-208-822-11	METAL CHIP	47K 0.50% 1/10W	R7004	1-216-097-91	METAL GLAZE	100K 5% 1/10W
R2048	1-216-049-91	METAL GLAZE	1K 5% 1/10W	R7005	1-216-025-91	METAL GLAZE	100 5% 1/10W
R2049	1-216-049-91	METAL GLAZE	1K 5% 1/10W	R7006	1-216-025-91	METAL GLAZE	100 5% 1/10W
R2050	1-218-754-11	METAL CHIP	120K 0.50% 1/10W	R7007	1-216-025-91	METAL GLAZE	100 5% 1/10W
R2052	1-216-677-11	METAL CHIP	12K 0.50% 1/10W	R7008	1-216-025-91	METAL GLAZE	100 5% 1/10W
R2055	1-216-678-11	METAL CHIP	13K 0.50% 1/10W	R7009	1-216-097-91	METAL GLAZE	100K 5% 1/10W
R2062	1-208-806-11	METAL CHIP	10K 0.50% 1/10W	R7010	1-216-097-91	METAL GLAZE	100K 5% 1/10W
R2063	1-216-682-11	METAL CHIP	20K 0.50% 1/10W	R7011	1-216-097-91	METAL GLAZE	100K 5% 1/10W
R2064	1-216-690-11	METAL CHIP	43K 0.50% 1/10W	R7012	1-216-097-91	METAL GLAZE	100K 5% 1/10W
R2065	1-216-690-11	METAL CHIP	43K 0.50% 1/10W	R7013	1-216-073-00	METAL GLAZE	10K 5% 1/10W
R2066	1-216-049-91	METAL GLAZE	1K 5% 1/10W	R7014	1-216-097-91	METAL GLAZE	100K 5% 1/10W
R2067	1-216-073-00	METAL GLAZE	10K 5% 1/10W	R7015	1-216-097-91	METAL GLAZE	100K 5% 1/10W
R2070	1-216-123-11	METAL GLAZE	1.2M 5% 1/10W	R7016	1-216-097-91	METAL GLAZE	100K 5% 1/10W
R2963	1-216-657-11	METAL CHIP	1.8K 0.50% 1/10W	R7017	1-216-097-91	METAL GLAZE	100K 5% 1/10W
R5002	1-249-397-11	CARBON	22 5% 1/4W F	R7018	1-216-097-91	METAL GLAZE	100K 5% 1/10W
R5003	1-216-065-00	METAL GLAZE	4.7K 5% 1/10W	R7019	1-216-097-91	METAL GLAZE	100K 5% 1/10W
R5006	1-247-863-91	CARBON	22K 5% 1/4W	R7020	1-216-097-91	METAL GLAZE	100K 5% 1/10W
R6001	1-208-774-11	METAL GLAZE	470 5% 1/10W	R7021	1-216-097-91	METAL GLAZE	100K 5% 1/10W
R6003	1-216-041-00	METAL GLAZE	470 5% 1/10W	R7022	1-216-097-91	METAL GLAZE	100K 5% 1/10W
R6004	1-216-041-00	METAL GLAZE	470 5% 1/10W	R7023	1-216-097-91	METAL GLAZE	100K 5% 1/10W
R6006	1-216-041-00	METAL GLAZE	470 5% 1/10W	R7024	1-216-097-91	METAL GLAZE	100K 5% 1/10W
R6011	1-216-097-91	METAL GLAZE	100K 5% 1/10W	R7025	1-216-097-91	METAL GLAZE	100K 5% 1/10W
R6551	1-216-041-00	METAL GLAZE	470 5% 1/10W	R7026	1-216-097-91	METAL GLAZE	100K 5% 1/10W
R6552	1-216-041-00	METAL GLAZE	470 5% 1/10W	R7030	1-216-073-00	METAL GLAZE	10K 5% 1/10W
R6553	1-216-041-00	METAL GLAZE	470 5% 1/10W	R7031	1-216-073-00	METAL GLAZE	10K 5% 1/10W
R6554	1-216-041-00	METAL GLAZE	470 5% 1/10W	R7032	1-216-041-00	METAL GLAZE	470 5% 1/10W
R6555	1-216-025-91	METAL GLAZE	100 5% 1/10W	R7037	1-216-065-00	METAL GLAZE	4.7K 5% 1/10W
R6556	1-216-025-91	METAL GLAZE	100 5% 1/10W	< TRANSFORMER >			
R6557	1-216-061-00	METAL GLAZE	3.3K 5% 1/10W	T5000	1-426-668-11	TRANSFORMER, FERRITE (HDT)	
R6558	1-216-025-91	METAL GLAZE	100 5% 1/10W	T5001	1-429-350-11	TRANSFORMER, FERRITE (HMT)	
R6559	1-216-025-91	METAL GLAZE	100 5% 1/10W	T5002	1-429-349-11	TRANSFORMER, FERRITE (HOT)	
R6560	1-216-025-91	METAL GLAZE	100 5% 1/10W	< TEST PIN >			
R6561	1-216-025-91	METAL GLAZE	100 5% 1/10W	TP7	1-537-864-11	PIN, POST	
R6562	1-216-025-91	METAL GLAZE	100 5% 1/10W	TP8	1-537-864-11	PIN, POST	
R6564	1-216-025-91	METAL GLAZE	100 5% 1/10W	TP2011	1-537-864-11	PIN, POST	
R6565	1-216-025-91	METAL GLAZE	100 5% 1/10W	TP2012	1-537-864-11	PIN, POST (20E1E/20E1U/20F1E/20F1U)	
R6566	1-216-025-91	METAL GLAZE	100 5% 1/10W	TP2013	1-537-864-11	PIN, POST	
R6567	1-216-025-91	METAL GLAZE	100 5% 1/10W	TP2014	1-537-864-11	PIN, POST	
R6568	1-216-025-91	METAL GLAZE	100 5% 1/10W	TP2015	1-537-864-11	PIN, POST (20E1E/20E1U/20F1E/20F1U)	
R6569	1-216-025-91	METAL GLAZE	100 5% 1/10W	TP2018	1-537-864-11	PIN, POST	
R6570	1-216-025-91	METAL GLAZE	100 5% 1/10W	TP2024	1-537-864-11	PIN, POST	
R6571	1-216-025-91	METAL GLAZE	100 5% 1/10W	< CRYSTAL >			
R6572	1-216-025-91	METAL GLAZE	100 5% 1/10W	X7001	1-578-689-21	VIBRATOR	
R6574	1-216-025-91	METAL GLAZE	100 5% 1/10W				
R6575	1-216-025-91	METAL GLAZE	100 5% 1/10W				
R6576	1-216-025-91	METAL GLAZE	100 5% 1/10W				

\*\*\*\*\*

REF NO.	PART NO.	DESCRIPTION	REMARK	REF NO.	PART NO.	DESCRIPTION	REMARK
	*A-1372-133-A	MOUNTED PCB, HA (14E5E/14E5U/14F5E/14F5U/ BKM-10R) *****		D223	8-719-987-45	DIODE CL-155Y/PG-CD (CONTRAST)	
		< CAPACITOR >		D224	8-719-987-45	DIODE CL-155Y/PG-CD (BRIGHT)	
C201	1-126-206-11	ELECT 100μ F 20% 6.3V		D225	8-719-987-45	DIODE CL-155Y/PG-CD (CHROMA)	
C202	1-126-206-11	ELECT 100μ F 20% 6.3V		D226	8-719-987-45	DIODE CL-155Y/PG-CD (PHASE)	
C203	1-126-206-11	ELECT 100μ F 20% 6.3V				< IC >	
C204	1-126-206-11	ELECT 100μ F 20% 6.3V		IC201	8-752-842-86	IC CXP2003M	
C205	1-126-206-11	ELECT 100μ F 20% 6.3V		IC202	8-752-842-86	IC CXP2003M	
						< TRANSISTOR >	
C206	1-126-206-11	ELECT 100μ F 20% 6.3V		Q201	8-729-901-01	TRANSISTOR DTC144EK	
C207	1-126-206-11	ELECT 100μ F 20% 6.3V		Q202	8-729-921-12	TRANSISTOR 2SD1834	
C211	1-163-031-11	CERAMIC CHIP 0.01μ F 50V		Q203	8-729-921-12	TRANSISTOR 2SD1834	
C212	1-163-031-11	CERAMIC CHIP 0.01μ F 50V				< RESISTOR >	
C213	1-163-031-11	CERAMIC CHIP 0.01μ F 50V		R201	1-216-043-91	METAL GLAZE 560 5% 1/10W	
C214	1-163-031-11	CERAMIC CHIP 0.01μ F 50V		R202	1-216-043-91	METAL GLAZE 560 5% 1/10W	
C215	1-163-031-11	CERAMIC CHIP 0.01μ F 50V		R203	1-216-043-91	METAL GLAZE 560 5% 1/10W	
C216	1-163-031-11	CERAMIC CHIP 0.01μ F 50V		R204	1-216-043-91	METAL GLAZE 560 5% 1/10W	
C217	1-163-031-11	CERAMIC CHIP 0.01μ F 50V		R205	1-216-097-91	METAL GLAZE 100K 5% 1/10W	
C301	1-163-031-11	CERAMIC CHIP 0.01μ F 50V		R206	1-216-049-91	METAL GLAZE 1K 5% 1/10W	
C302	1-163-031-11	CERAMIC CHIP 0.01μ F 50V		R207	1-216-049-91	METAL GLAZE 1K 5% 1/10W	
C303	1-163-031-11	CERAMIC CHIP 0.01μ F 50V		R208	1-216-065-00	METAL GLAZE 4.7K 5% 1/10W	
C304	1-163-031-11	CERAMIC CHIP 0.01μ F 50V		R209	1-216-049-91	METAL GLAZE 1K 5% 1/10W	
C305	1-163-031-11	CERAMIC CHIP 0.01μ F 50V		R210	1-216-097-91	METAL GLAZE 100K 5% 1/10W	
C306	1-163-031-11	CERAMIC CHIP 0.01μ F 50V		R211	1-216-085-00	METAL GLAZE 33K 5% 1/10W	
C307	1-163-031-11	CERAMIC CHIP 0.01μ F 50V		R212	1-216-095-00	METAL GLAZE 82K 5% 1/10W	
C308	1-163-031-11	CERAMIC CHIP 0.01μ F 50V		R213	1-216-085-00	METAL GLAZE 33K 5% 1/10W	
		< CONNECTOR >		R214	1-216-095-00	METAL GLAZE 82K 5% 1/10W	
CN201	*1-564-005-11	PIN, CONNECTOR 6P		R215	1-216-089-91	METAL GLAZE 47K 5% 1/10W	
CN202	*1-564-009-11	PIN, CONNECTOR 10P		R216	1-216-089-91	METAL GLAZE 47K 5% 1/10W	
		< DIODE >		R217	1-216-089-91	METAL GLAZE 47K 5% 1/10W	
D201	8-719-404-46	DIODE MA110		R301	1-216-065-00	METAL GLAZE 4.7K 5% 1/10W	
D202	8-719-404-46	DIODE MA110		R302	1-216-065-00	METAL GLAZE 4.7K 5% 1/10W	
D203	8-719-404-46	DIODE MA110		R303	1-216-065-00	METAL GLAZE 4.7K 5% 1/10W	
D204	8-719-404-46	DIODE MA110		R304	1-216-065-00	METAL GLAZE 4.7K 5% 1/10W	
D205	8-719-404-46	DIODE MA110		R305	1-216-065-00	METAL GLAZE 4.7K 5% 1/10W	
D206	8-719-404-46	DIODE MA110		R306	1-216-065-00	METAL GLAZE 4.7K 5% 1/10W	
D207	8-719-404-46	DIODE MA110		R307	1-216-065-00	METAL GLAZE 4.7K 5% 1/10W	
D208	8-719-404-46	DIODE MA110		R308	1-216-065-00	METAL GLAZE 4.7K 5% 1/10W	
D209	8-719-404-46	DIODE MA110				< SWITCH >	
D210	8-719-404-46	DIODE MA110		S201	1-692-037-31	SWITCH, KEY BOARD (POWER)	
D211	8-719-404-46	DIODE MA110		S202	1-692-037-31	SWITCH, KEY BOARD (DEGAUSS)	
D212	8-719-404-46	DIODE MA110		S203	1-692-037-31	SWITCH, KEY BOARD (1)	
D213	8-719-404-46	DIODE MA110		S204	1-692-037-31	SWITCH, KEY BOARD (2)	
D214	8-719-404-46	DIODE MA110		S205	1-692-037-31	SWITCH, KEY BOARD (3)	
D215	8-719-404-46	DIODE MA110		S206	1-692-037-31	SWITCH, KEY BOARD (Del)	
D216	8-719-404-46	DIODE MA110		S207	1-692-037-31	SWITCH, KEY BOARD (4)	
D217	8-719-404-46	DIODE MA110		S208	1-692-037-31	SWITCH, KEY BOARD (5)	
D218	8-719-404-46	DIODE MA110		S209	1-692-037-31	SWITCH, KEY BOARD (6)	
D219	8-719-404-46	DIODE MA110		S210	1-692-037-31	SWITCH, KEY BOARD (0)	
D220	8-719-404-46	DIODE MA110		S211	1-692-037-31	SWITCH, KEY BOARD (7)	
D221	8-719-404-46	DIODE MA110		S212	1-692-037-31	SWITCH, KEY BOARD (8)	
D222	8-719-404-46	DIODE MA110		S213	1-692-037-31	SWITCH, KEY BOARD (9)	

REF NO.	PART NO.	DESCRIPTION	REMARK	REF NO.	PART NO.	DESCRIPTION	REMARK
S214	1-692-037-31	SWITCH, KEY BOARD (Ent)				< TRANSISTOR >	
S215	1-692-037-31	SWITCH, KEY BOARD (MANUAL CONTRAST)					
S216	1-692-037-31	SWITCH, KEY BOARD (MANUAL BRIGHT)		Q101	8-729-921-12	TRANSISTOR 2SD1834	
S217	1-692-037-31	SWITCH, KEY BOARD (MANUAL CHROMA)		Q102	8-729-921-12	TRANSISTOR 2SD1834	
S218	1-692-037-31	SWITCH, KEY BOARD (MANUAL PHASE)		Q103	8-729-901-01	TRANSISTOR DTC144EK	
S219	1-692-037-31	SWITCH, KEY BOARD (MENU)				< RESISTOR >	
S220	1-692-037-31	SWITCH, KEY BOARD (ENTER)					
S221	1-692-037-31	SWITCH, KEY BOARD (UP)		R101	1-216-043-91	METAL GLAZE 560	5% 1/10W
S222	1-692-037-31	SWITCH, KEY BOARD (DOWN)		R102	1-216-043-91	METAL GLAZE 560	5% 1/10W
S231	1-473-469-11	ENCODER, ROTARY (CONTRAST)		R103	1-216-043-91	METAL GLAZE 560	5% 1/10W
S232	1-473-469-11	ENCODER, ROTARY (BRIGHT)		R104	1-216-043-91	METAL GLAZE 560	5% 1/10W
S233	1-473-469-11	ENCODER, ROTARY (CHROMA)		R105	1-216-043-91	METAL GLAZE 560	5% 1/10W
S234	1-473-469-11	ENCODER, ROTARY (PHASE)		R106	1-216-043-91	METAL GLAZE 560	5% 1/10W
				R107	1-216-043-91	METAL GLAZE 560	5% 1/10W
				R108	1-216-043-91	METAL GLAZE 560	5% 1/10W
				R109	1-216-043-91	METAL GLAZE 560	5% 1/10W
				R110	1-216-043-91	METAL GLAZE 560	5% 1/10W
*****							
	*A-1372-134-A	MOUNTED PCB, HB (14E5E/14E5U/14F5E/14F5U/ BKM-10R)		R112	1-216-097-91	METAL GLAZE 100K	5% 1/10W
		*****		R113	1-216-049-91	METAL GLAZE 1K	5% 1/10W
		< CAPACITOR >		R114	1-216-049-91	METAL GLAZE 1K	5% 1/10W
C101	1-126-391-11	ELECT CHIP 47μ F 20% 6.3V		R115	1-216-049-91	METAL GLAZE 1K	5% 1/10W
C102	1-126-391-11	ELECT CHIP 47μ F 20% 6.3V		R116	1-216-097-91	METAL GLAZE 100K	5% 1/10W
C111	1-163-031-11	CERAMIC CHIP 0.01μ F 50V		R117	1-216-065-00	METAL GLAZE 4.7K	5% 1/10W
C112	1-163-031-11	CERAMIC CHIP 0.01μ F 50V		R121	1-216-085-00	METAL GLAZE 33K	5% 1/10W
C113	1-163-031-11	CERAMIC CHIP 0.01μ F 50V		R122	1-216-095-00	METAL GLAZE 82K	5% 1/10W
		< CONNECTOR >		R123	1-216-085-00	METAL GLAZE 33K	5% 1/10W
CN101	1-506-471-11	PIN, CONNECTOR 6P		R124	1-216-095-00	METAL GLAZE 82K	5% 1/10W
		< DIODE >		R125	1-216-089-91	METAL GLAZE 47K	5% 1/10W
D101	8-719-404-46	DIODE MA110		R126	1-216-089-91	METAL GLAZE 47K	5% 1/10W
D102	8-719-404-46	DIODE MA110		R127	1-216-089-91	METAL GLAZE 47K	5% 1/10W
D103	8-719-404-46	DIODE MA110				< SWITCH >	
D104	8-719-404-46	DIODE MA110		S101	1-692-037-31	SWITCH, KEY BOARD ((SHIFT))	
D105	8-719-404-46	DIODE MA110		S102	1-692-037-31	SWITCH, KEY BOARD ( □ (16:9))	
D106	8-719-404-46	DIODE MA110		S103	1-692-037-31	SWITCH, KEY BOARD ( ■ (SYNC))	
D107	8-719-404-46	DIODE MA110		S104	1-692-037-31	SWITCH, KEY BOARD ( ■ (BLUE ONLY))	
D108	8-719-404-46	DIODE MA110		S105	1-692-037-31	SWITCH, KEY BOARD (COMB(R))	
D109	8-719-404-46	DIODE MA110		S106	1-692-037-31	SWITCH, KEY BOARD (APT(G))	
D110	8-719-404-46	DIODE MA110		S107	1-692-037-31	SWITCH, KEY BOARD (MONO(B))	
D121	8-719-987-45	DIODE CL-155Y/PG-CD		S108	1-692-037-31	SWITCH, KEY BOARD (F1(F3))	
D122	8-719-987-45	DIODE CL-155Y/PG-CD		S109	1-692-037-31	SWITCH, KEY BOARD (F2(F4))	
D123	8-719-987-45	DIODE CL-155Y/PG-CD		S110	1-692-037-31	SWITCH, KEY BOARD (REMOTE(SAFE AREA))	
D124	8-719-987-45	DIODE CL-155Y/PG-CD		*****			
D125	8-719-987-45	DIODE CL-155Y/PG-CD				*A-1375-149-A	COMPLETE PCB, HC (14E5E/14E5U/14F5E/14F5U /BKM-10R)
D126	8-719-987-45	DIODE CL-155Y/PG-CD				*****	
D127	8-719-987-45	DIODE CL-155Y/PG-CD				3-741-396-01	INSULATOR
D128	8-719-987-45	DIODE CL-155Y/PG-CD				7-628-253-35	SCREW +PS 2X8
D129	8-719-987-45	DIODE CL-155Y/PG-CD				7-688-001-01	W 2, SMALL
D130	8-719-987-45	DIODE CL-155Y/PG-CD					< CAPACITOR >
		< IC >		C1	1-163-227-11	CERAMIC CHIP 10pF	0.5pF 50V
IC101	8-752-842-86	IC CXP2003M		C2	1-163-227-11	CERAMIC CHIP 10pF	0.5pF 50V
IC102	8-752-842-86	IC CXP2003M		C4	1-163-031-11	CERAMIC CHIP 0.01μ F	50V
				C7	1-163-031-11	CERAMIC CHIP 0.01μ F	50V

REF NO.	PART NO.	DESCRIPTION	REMARK	REF NO.	PART NO.	DESCRIPTION	REMARK
C8	1-163-031-11	CERAMIC CHIP	0.01μ F	50V		< IC >	
C50	1-163-031-11	CERAMIC CHIP	0.01μ F	50V	IC1	8-759-387-33	IC HD6473258P10-EG1.0
C51	1-163-031-11	CERAMIC CHIP	0.01μ F	50V	IC2	8-759-991-19	IC PST529CMT
C52	1-163-031-11	CERAMIC CHIP	0.01μ F	50V	IC3	8-759-236-11	IC TC74HC138AF (EL)
C53	1-163-031-11	CERAMIC CHIP	0.01μ F	50V	IC4	8-759-236-83	IC TC74HC245AF (EL)
C54	1-163-031-11	CERAMIC CHIP	0.01μ F	50V	IC5	8-759-237-59	IC TC74HC541AF (EL)
C55	1-163-031-11	CERAMIC CHIP	0.01μ F	50V	IC6	8-759-237-59	IC TC74HC541AF (EL)
C56	1-163-031-11	CERAMIC CHIP	0.01μ F	50V	IC7	8-759-237-75	IC TC74HC574AF (EL)
C57	1-163-031-11	CERAMIC CHIP	0.01μ F	50V	IC8	8-759-236-83	IC TC74HC245AF (EL)
C58	1-163-031-11	CERAMIC CHIP	0.01μ F	50V	IC9	8-759-235-31	IC TC74HC14AF (EL)
C59	1-163-031-11	CERAMIC CHIP	0.01μ F	50V	IC10	8-759-235-31	IC TC74HC14AF (EL)
C60	1-163-031-11	CERAMIC CHIP	0.01μ F	50V	IC11	8-759-237-75	IC TC74HC574AF (EL)
C61	1-163-031-11	CERAMIC CHIP	0.01μ F	50V	IC12	8-759-236-79	IC TC74HC244AF (EL)
C62	1-163-031-11	CERAMIC CHIP	0.01μ F	50V	IC13	8-759-061-67	IC MC34051M
C63	1-163-031-11	CERAMIC CHIP	0.01μ F	50V	IC14	8-759-925-72	IC SN74HC02ANS
C64	1-163-031-11	CERAMIC CHIP	0.01μ F	50V	IC16	1-810-899-11	IC MAX877CSA
C65	1-163-031-11	CERAMIC CHIP	0.01μ F	50V	IC21	8-759-032-26	IC MC74HC125AF
C66	1-163-031-11	CERAMIC CHIP	0.01μ F	50V		< IC SOCKET >	
C67	1-163-031-11	CERAMIC CHIP	0.01μ F	50V			
C68	1-163-031-11	CERAMIC CHIP	0.01μ F	50V			
C71	1-163-031-11	CERAMIC CHIP	0.01μ F	50V	ICS1	1-540-044-11	SOCKET, IC
C81	1-126-206-11	ELECT	100μ F	20% 6.3V		< CHIP CONDUCTOR >	
C82	1-126-206-11	ELECT	100μ F	20% 6.3V			
C83	1-126-206-11	ELECT	100μ F	20% 6.3V	JR1	1-216-296-91	CONDUCTOR, CHIP (3216)
C84	1-126-206-11	ELECT	100μ F	20% 6.3V		< COIL >	
C85	1-126-206-11	ELECT	100μ F	20% 6.3V			
C86	1-126-206-11	ELECT	100μ F	20% 6.3V	L1	1-412-539-11	INDUCTOR 150μ H
C87	1-126-206-11	ELECT	100μ F	20% 6.3V	L2	1-412-537-31	INDUCTOR 100μ H
C88	1-126-206-11	ELECT	100μ F	20% 6.3V	L3	1-412-531-31	INDUCTOR 33μ H
C89	1-126-206-11	ELECT	100μ F	20% 6.3V		< TRANSISTOR >	
C90	1-126-206-11	ELECT	100μ F	20% 6.3V			
C91	1-126-396-11	ELECT CHIP	47μ F	20% 16V	Q1	8-729-901-01	TRANSISTOR DTC144EK
C92	1-126-396-11	ELECT CHIP	47μ F	20% 16V	Q2	8-729-901-01	TRANSISTOR DTC144EK
C93	1-126-396-11	ELECT CHIP	47μ F	20% 16V	Q3	8-729-122-13	TRANSISTOR 2SA1221-K
		< CONNECTOR >			Q4	8-729-122-13	TRANSISTOR 2SA1221-K
CN1	1-774-534-11	CONNECTOR, IC CARD			Q5	8-729-901-01	TRANSISTOR DTC144EK
CN2	1-506-474-11	PIN, CONNECTOR 9P			Q6	8-729-901-01	TRANSISTOR DTC144EK
CN3	*1-564-009-11	PIN, CONNECTOR 10P				< RESISTOR >	
CN4	*1-564-005-11	PIN, CONNECTOR 6P					
CN5	1-506-471-11	PIN, CONNECTOR 6P			R1	1-216-073-00	METAL GLAZE 10K 5% 1/10W
		< DIODE >			R2	1-216-295-91	CONDUCTOR, CHIP (2012)
D1	8-719-037-00	DIODE RD6.2SB2-T1			R3	1-216-073-00	METAL GLAZE 10K 5% 1/10W
D2	8-719-037-00	DIODE RD6.2SB2-T1			R4	1-216-073-00	METAL GLAZE 10K 5% 1/10W
D3	8-719-037-00	DIODE RD6.2SB2-T1			R5	1-216-073-00	METAL GLAZE 10K 5% 1/10W
D4	8-719-037-00	DIODE RD6.2SB2-T1			R6	1-216-073-00	METAL GLAZE 10K 5% 1/10W
D5	8-719-037-00	DIODE RD6.2SB2-T1			R8	1-216-065-00	METAL GLAZE 4.7K 5% 1/10W
D6	8-719-037-00	DIODE RD6.2SB2-T1			R9	1-216-077-00	METAL GLAZE 15K 5% 1/10W
D7	8-719-037-00	DIODE RD6.2SB2-T1			R10	1-216-057-00	METAL GLAZE 2.2K 5% 1/10W
D8	8-719-037-00	DIODE RD6.2SB2-T1			R11	1-216-069-00	METAL GLAZE 6.8K 5% 1/10W
D10	8-719-210-39	DIODE EC10QS-04			R12	1-216-073-00	METAL GLAZE 10K 5% 1/10W
					R13	1-216-073-00	METAL GLAZE 10K 5% 1/10W
					R14	1-216-073-00	METAL GLAZE 10K 5% 1/10W
					R15	1-216-073-00	METAL GLAZE 10K 5% 1/10W
					R16	1-216-073-00	METAL GLAZE 10K 5% 1/10W

REF NO.	PART NO.	DESCRIPTION	REMARK	REF NO.	PART NO.	DESCRIPTION	REMARK
R17	1-216-073-00	METAL GLAZE	10K 5% 1/10W	R79	1-216-097-91	METAL GLAZE	100K 5% 1/10W
R18	1-216-073-00	METAL GLAZE	10K 5% 1/10W	R80	1-216-097-91	METAL GLAZE	100K 5% 1/10W
R19	1-216-073-00	METAL GLAZE	10K 5% 1/10W	R81	1-216-097-91	METAL GLAZE	100K 5% 1/10W
R20	1-216-073-00	METAL GLAZE	10K 5% 1/10W	R82	1-216-097-91	METAL GLAZE	100K 5% 1/10W
R21	1-216-049-91	METAL GLAZE	1K 5% 1/10W	R83	1-216-097-91	METAL GLAZE	100K 5% 1/10W
R22	1-216-049-91	METAL GLAZE	1K 5% 1/10W	R84	1-216-097-91	METAL GLAZE	100K 5% 1/10W
R23	1-216-049-91	METAL GLAZE	1K 5% 1/10W	R85	1-216-097-91	METAL GLAZE	100K 5% 1/10W
R24	1-216-049-91	METAL GLAZE	1K 5% 1/10W	R86	1-216-097-91	METAL GLAZE	100K 5% 1/10W
R25	1-216-049-91	METAL GLAZE	1K 5% 1/10W	R87	1-216-097-91	METAL GLAZE	100K 5% 1/10W
R26	1-216-049-91	METAL GLAZE	1K 5% 1/10W	R88	1-216-097-91	METAL GLAZE	100K 5% 1/10W
R27	1-216-049-91	METAL GLAZE	1K 5% 1/10W	R89	1-216-097-91	METAL GLAZE	100K 5% 1/10W
R28	1-216-049-91	METAL GLAZE	1K 5% 1/10W	R90	1-216-097-91	METAL GLAZE	100K 5% 1/10W
R31	1-216-089-91	METAL GLAZE	47K 5% 1/10W	R91	1-216-097-91	METAL GLAZE	100K 5% 1/10W
R32	1-216-089-91	METAL GLAZE	47K 5% 1/10W	R92	1-216-097-91	METAL GLAZE	100K 5% 1/10W
R33	1-216-089-91	METAL GLAZE	47K 5% 1/10W	R93	1-216-097-91	METAL GLAZE	100K 5% 1/10W
R34	1-216-089-91	METAL GLAZE	47K 5% 1/10W	R94	1-216-097-91	METAL GLAZE	100K 5% 1/10W
R35	1-216-089-91	METAL GLAZE	47K 5% 1/10W			< CRYSTAL >	
R36	1-216-089-91	METAL GLAZE	47K 5% 1/10W	X1	1-577-121-11	VIBRATOR, CRYSTAL (20MHz)	
R37	1-216-089-91	METAL GLAZE	47K 5% 1/10W			*****	
R38	1-216-089-91	METAL GLAZE	47K 5% 1/10W			* A-1372-136-A MOUNTED PCB, HD 14E1E/14E1U/14F1E/14F1U	
R39	1-216-065-00	METAL GLAZE	4.7K 5% 1/10W			20E1E/20E1U/20F1E/20F1U/	
R40	1-216-065-00	METAL GLAZE	4.7K 5% 1/10W			BKM-10R)	
R41	1-216-073-00	METAL GLAZE	10K 5% 1/10W			*****	
R42	1-216-073-00	METAL GLAZE	10K 5% 1/10W			< CONNECTOR >	
R43	1-216-073-00	METAL GLAZE	10K 5% 1/10W	CN101	1-565-269-11	SOCKET, CONNECTOR (D-DUB,L) 9P	
R44	1-216-073-00	METAL GLAZE	10K 5% 1/10W	CN102	1-506-474-11	PIN, CONNECTOR 9P	
R45	1-216-089-91	METAL GLAZE	47K 5% 1/10W			< DIODE >	
R48	1-216-061-00	METAL GLAZE	3.3K 5% 1/10W	D101	8-719-037-00	DIODE RD6.2SB2-T1	
R49	1-216-061-00	METAL GLAZE	3.3K 5% 1/10W	D102	8-719-037-00	DIODE RD6.2SB2-T1	
R51	1-216-089-91	METAL GLAZE	47K 5% 1/10W	D103	8-719-037-00	DIODE RD6.2SB2-T1	
R52	1-216-089-91	METAL GLAZE	47K 5% 1/10W	D104	8-719-037-00	DIODE RD6.2SB2-T1	
R53	1-216-089-91	METAL GLAZE	47K 5% 1/10W	D105	8-719-037-00	DIODE RD6.2SB2-T1	
R54	1-216-089-91	METAL GLAZE	47K 5% 1/10W			*****	
R55	1-216-089-91	METAL GLAZE	47K 5% 1/10W			* A-1373-542-A MOUNTED PCB, YA (14E1E/14E1U/14E5E/14E5U/	
R56	1-216-089-91	METAL GLAZE	47K 5% 1/10W			14F1E/14F1U/14F5E/14F5U)	
R57	1-216-089-91	METAL GLAZE	47K 5% 1/10W			*****	
R58	1-216-089-91	METAL GLAZE	47K 5% 1/10W			* A-1373-523-A MOUNTED PCB, YA (20E1E/20E1U/20F1E/20F1U)	
R60	1-216-089-91	METAL GLAZE	47K 5% 1/10W			*****	
R61	1-216-089-91	METAL GLAZE	47K 5% 1/10W			< DIODE >	
R62	1-216-089-91	METAL GLAZE	47K 5% 1/10W	D101	8-719-055-74	DIODE SEL6910D-D	
R63	1-216-089-91	METAL GLAZE	47K 5% 1/10W	D102	8-719-055-74	DIODE SEL6910D-D	
R64	1-216-089-91	METAL GLAZE	47K 5% 1/10W	D103	8-719-055-74	DIODE SEL6910D-D	
R65	1-216-089-91	METAL GLAZE	47K 5% 1/10W	D104	8-719-055-74	DIODE SEL6910D-D	
R66	1-216-089-91	METAL GLAZE	47K 5% 1/10W	D105	8-719-055-74	DIODE SEL6910D-D	
R67	1-216-089-91	METAL GLAZE	47K 5% 1/10W	D106	8-719-055-74	DIODE SEL6910D-D	
R68	1-316-097-91	METAL GLAZE	100K 5% 1/10W			*****	
R69	1-216-049-91	METAL GLAZE	1K 5% 1/10W				
R71	1-216-097-91	METAL GLAZE	100K 5% 1/10W				
R72	1-216-097-91	METAL GLAZE	100K 5% 1/10W				
R73	1-216-097-91	METAL GLAZE	100K 5% 1/10W				
R74	1-216-097-91	METAL GLAZE	100K 5% 1/10W				
R75	1-216-097-91	METAL GLAZE	100K 5% 1/10W				
R76	1-216-097-91	METAL GLAZE	100K 5% 1/10W				
R77	1-216-097-91	METAL GLAZE	100K 5% 1/10W				
R78	1-216-097-91	METAL GLAZE	100K 5% 1/10W				



The components identified by shading and marked  $\Delta$  are critical for safety. Replace only with the part number specified.

Les composants identifiés par une trame et une marque  $\Delta$  sont critiques pour la sécurité. Ne les remplacer que par une pièce portant le numéro spécifié.

**YB** **YC** **TA** **TB**

REF NO.	PART NO.	DESCRIPTION	REMARK	REF NO.	PART NO.	DESCRIPTION	REMARK
	*A-1373-543-A	MOUNTED PCB, YB (14E1E/14E1U/14E5E/14E5U/14F1E/14F1U/14F5E/14F5U) *****		CN20	1-774-536-11	CONNECTOR PIN (PC BOARD) 34P (14E5E/14E5U/14F5E/14F5U/20E1E/20E1U/20F1E/20F1U)	
	*A-1373-524-A	MOUNTED PCB, YB (20E1E/20E1U/20F1E/20F1U) ***** < DIODE >		CN21	*1-564-507-11	PLUG, CONNECTOR 4P (14E5E/14E5U/14F5E/14F5U/20E1E/20E1U/20F1E/20F1U)	
D201	8-719-055-74	DIODE SEL6910D-D		CN22	*1-564-704-11	PIN, CONNECTOR (SMALL TYPE) 2P (14E5E/14E5U/14F5E/14F5U/20E1E/20E1U/20F1E/20F1U)	
D202	8-719-055-70	DIODE SEL6210S-D		CN23	1-564-505-11	PLUG, CONNECTOR 2P (14E5E/14E5U/14F5E/14F5U/20E1E/20E1U/20F1E/20F1U)	
D203	8-719-055-72	DIODE SEL6410E-D		CN24	1-564-506-11	PLUG, CONNECTOR 3P (14E5E/14E5U/14F5E/14F5U/20E1E/20E1U/20F1E/20F1U)	
*****				*****			
	*A-1373-525-A	MOUNTED PCB, YC ***** < DIODE >		*A-1390-531-A	MOUNTED PCB, TB (14E1E/14E1U/14F1E/14F1U) *****		
CN301	1-506-487-11	PIN, CONNECTOR 8P		*A-1390-533-A	MOUNTED PCB, TB (20E1E/20E1U) *****		
CN302	1-774-533-11	SOCKET, SMALL TYPE DIN (8P)		*A-1390-606-A	MOUNTED PCB, TB (14E5E/14E5U/14F5E/14F5U) *****		
*****				< CONNECTOR >			
	*A-1390-532-A	MOUNTED PCB, TA (14E5E/14E5U/14F5E/14F5U/20E1E/20E1U/20F1E/20F1U) *****		CN1	1-774-525-11	SOCKET, CONNECTOR 64P	
	*A-1390-530-A	MOUNTED PCB, TA (14E1E/14E1U/14F1E/14F1U) ***** < CONNECTOR >		CN2	1-774-525-11	SOCKET, CONNECTOR 64P	
CN11	1-774-525-11	SOCKET, CONNECTOR 64P (14E1E/14E1U/14F1E/14F1U)		CN3	1-774-525-11	SOCKET, CONNECTOR 64P	
CN12	1-774-525-11	SOCKET, CONNECTOR 64P (14E1E/14E1U/14F1E/14F1U)		CN4	1-774-525-11	SOCKET, CONNECTOR 64P	
CN13	1-774-525-11	SOCKET, CONNECTOR 64P (14E1E/14E1U/14F1E/14F1U)		CN5	1-774-525-11	SOCKET, CONNECTOR 64P	
CN14	1-774-537-11	CONNECTOR PIN (PC BOARD) 50P (14E1E/14E1U/14F1E/14F1U)		CN6	1-774-525-11	SOCKET, CONNECTOR 64P	
CN15	1-774-525-11	SOCKET, CONNECTOR 64P (14E5E/14E5U/14F5E/14F5U/20E1E/20E1U/20F1E/20F1U)		CN7	1-774-525-11	SOCKET, CONNECTOR 64P	
CN15	1-774-536-11	CONNECTOR PIN (PC BOARD) 34P (14E1E/14E1U/14F1E/14F1U)		CN8	1-774-525-11	SOCKET, CONNECTOR 64P	
CN16	1-774-525-11	SOCKET, CONNECTOR 64P (14E5E/14E5U/14F5E/14F5U/20E1E/20E1U/20F1E/20F1U)		CN9	1-774-525-11	SOCKET, CONNECTOR 64P (14E5E/14E5U/14F5E/14F5U/20E1E/20E1U/20F1E/20F1U)	
CN16	*1-564-507-11	PLUG, CONNECTOR 4P (14E1E/14E1U/14F1E/14F1U)		CN9	1-774-537-11	CONNECTOR PIN (PC BOARD) 50P (14E1E/14E1U/14F1E/14F1U)	
CN17	1-774-525-11	SOCKET, CONNECTOR 64P (14E5E/14E5U/14F5E/14F5U/20E1E/20E1U/20F1E/20F1U)		CN10	1-774-525-11	SOCKET, CONNECTOR 64P (14E5E/14E5U/14F5E/14F5U/20E1E/20E1U/20F1E/20F1U)	
CN17	*1-564-704-11	PIN, CONNECTOR (SMALL TYPE) 2P (14E1E/14E1U/14F1E/14F1U)		CN10	1-774-535-11	CONNECTOR PIN (PC BOARD) 26P (14E1E/14E1U/14F1E/14F1U)	
CN18	1-774-525-11	SOCKET, CONNECTOR 64P (14E5E/14E5U/14F5E/14F5U/20E1E/20E1U/20F1E/20F1U)		CN11	1-774-525-11	SOCKET, CONNECTOR 64P (14E5E/14E5U/14F5E/14F5U/20E1E/20E1U/20F1E/20F1U)	
CN18	1-564-505-11	PLUG, CONNECTOR 2P (14E1E/14E1U/14F1E/14F1U)		CN12	1-774-525-11	SOCKET, CONNECTOR 64P (14E5E/14E5U/14F5E/14F5U/20E1E/20E1U/20F1E/20F1U)	
CN19	1-774-537-11	CONNECTOR PIN (PC BOARD) 50P (14E5E/14E5U/14F5E/14F5U/20E1E/20E1U/20F1E/20F1U)		CN13	1-774-537-11	CONNECTOR PIN (PC BOARD) 50P (14E5E/14E5U/14F5E/14F5U/20E1E/20E1U/20F1E/20F1U)	
CN19	1-564-506-11	PLUG, CONNECTOR 3P (14E1E/14E1U/14F1E/14F1U)		CN14	1-774-535-11	CONNECTOR PIN (PC BOARD) 26P (14E5E/14E5U/14F5E/14F5U/20E1E/20E1U/20F1E/20F1U)	
*****				*****			
				MISCELLANEOUS (EXCEPT BKM-10R) *****			
				$\Delta$ 8-451-470-11 DYY20MPDM (20E1E/20E1U/20F1E/20F1U)			
				$\Delta$ 8-451-473-11 DYY14MPDT (14E1E/14E1U/14E5E/14E5U/14F1E/14F1U/14F5E/14F5U)			
				$\Delta$ 8-453-003-11 NA3012(M) (20E1E/20E1U/20F1E/20F1U)			
				$\Delta$ 1-452-436-41 NECKASSY, CRT (NA292) (14E1E/14E1U/14E5E/14E5U/14F1E/14F1U/14F5E/14F5U)			
				$\Delta$ 1-223-417-12 RESISTOR ASSY (HIGH-VOLTAGE)			

Les composants identifiés par une trame et une marque  $\Delta$  sont critiques pour la sécurité.  
Ne les remplacer que par une pièce portant le numéro spécifié.

The components identified by shading and marked  $\Delta$  are critical for safety.  
Replace only with the part number specified.

REF NO.	PART NO.	DESCRIPTION	REMARK	REF NO.	PART NO.	DESCRIPTION	REMARK
	$\Delta$ 1-411-657-11	COIL, LANDING CORRECTION (20E1E/20E1U/20F1E/20F1U)			*4-051-300-01	INDIVIDUAL CARTON (BKM-10R)	
	$\Delta$ 1-411-658-11	COIL, LANDING CORRECTION (14E1E/14E1U/14E5E/14E5U/14F1E/14F1U/14F5E/14F5U)			*4-051-321-03	INDIVIDUAL CARTON (20F1U)	
	$\Delta$ 1-411-659-11	COIL, DEMAGNETIC (20E1E/20E1U/20F1E/20F1U)			*4-051-322-02	TRAY (20E1E/20E1U/20F1E/20F1U)	
	$\Delta$ 1-411-660-11	COIL, DEMAGNETIC (14E1E/14E1U/14E5E/14E5U/14F1E/14F1U/14F5E/14F5U)			4-051-484-01	LABEL, TALLY (20E1E/20E1U/20F1E/20F1U)	
	1-900-214-33	LEADASSY, FOCUS (20E1E/20E1U/20F1E/20F1U)			*4-051-574-01	CUSHION (UPPER) (ASSY) (14E1E/14E1U/14F1E/14F1U)	
	1-900-214-62	LEADASSY, FOCUS (14E1E/14E1U/14E5E/14E5U/14F1E/14F1U/14F5E/14F5U)			*4-051-575-01	CUSHION (LOWER) (ASSY) (14E1E/14E1U/14F1E/14F1U)	
	1-452-032-11	MAGNET, DISK; 10MM $\emptyset$			*4-051-580-01	CUSHION (UPPER) (ASSY) (14E5E/14E5U/14F5E/14F5U)	
	1-452-094-00	MAGNET, ROTA TABLE DISK; 15MM $\emptyset$			*4-051-581-01	CUSHION (LOWER) (ASSY) (14E5E/14E5U/14F5E/14F5U)	
	X-4308-815-8	PERMALLOY ASSY, CONVERGENCE (14E1E/14E1U/14E5E/14E5U/14F1E/14F1U/14F5E/14F5U)			*4-051-603-03	INDIVIDUAL CARTON (20F1E)	
	X-4309-608-7	PERMALLOY ASSY, CONVERGENCE (20E1E/20E1U/20F1E/20F1U)			*4-051-705-01	INDIVIDUAL CARTON (14F1U)	
F1	$\Delta$ 1-532-746-11	FUSE, GLASS TUBE 4A/125V (14E1U/14E5U/14F1U/14F5U/20E1F/20F1U)			*4-051-706-01	INDIVIDUAL CARTON (14F1E)	
F1	$\Delta$ 1-576-230-31	FUSE (H.B.C) T3.15A/250V (14E1E/14E5E/14F1E/14F5E/20E1E/20F1E)			*4-051-708-01	INDIVIDUAL CARTON (14F5U)	
	1-533-702-11	HOLDER, FUSE (F1)			*4-051-709-01	INDIVIDUAL CARTON (14F5E)	
S901	$\Delta$ 1-762-300-11	SWITCH, AC POWER SEESAW			4-051-743-01	PLATE, TALLY (14E1E/14E1U/14E5E/14E5U/14F1E/14F1U/14F5E/14F5U)	
V901	$\Delta$ 8-736-374-05	PICTURE TUBE (20MT1) (20F1E: NORTH)			*4-051-772-01	BAG, PROTECTION (14E1E/14E1U/14F1E/14F1U)	
V901	$\Delta$ 8-736-375-05	PICTURE TUBE (20MT3) (20F1U)			*4-051-773-01	BAG, PROTECTION (14E5E/14E5U/14F5E/14F5U)	
V901	$\Delta$ 8-736-376-05	PICTURE TUBE (20MP1) (20E1E)			*4-052-544-02	INDIVIDUAL CARTON (20E1U)	
V901	$\Delta$ 8-736-385-05	PICTURE TUBE (20MT1 (S)) (20F1E: SOUTH)			*4-054-304-01	INDIVIDUAL CARTON (14E1U)	
V901	$\Delta$ 8-736-384-05	PICTURE TUBE (20MT1 (S)) (20F1E: SOUTH)			*4-054-305-01	INDIVIDUAL CARTON (14E1E)	
V901	$\Delta$ 8-738-334-05	PICTURE TUBE (14MT3) (BVM)(14F1U/14F5U)			*4-054-307-01	INDIVIDUAL CARTON (14E5U)	
V901	$\Delta$ 8-738-332-05	PICTURE TUBE (14MT1) (BVM) (14F1E/14F5E)			*4-054-308-01	INDIVIDUAL CARTON (14E5E)	
V901	$\Delta$ 8-738-337-05	PICTURE TUBE (14MP1) (14E1E/14E5E)			*4-054-360-01	INDIVIDUAL CARTON (20E1E)	
V901	$\Delta$ 8-738-338-05	PICTURE TUBE (14MP3) (14E1U/14E5U)			*4-381-155-01	BAG, PROTECTION (20E1E/20E1U/20F1E/20F1U)	
					*4-396-077-01	JOINT (20E1E/20E1U/20F1E/20F1U)	
V901	$\Delta$ 8-736-377-05	PICTURE TUBE (Y20MPDM) (20E1U)			7-682-564-04	SCREW +B 4X14 (BKM-10R)	
*****							
ACCESSORIES AND PACKING MATERIALS							
*****							
	$\Delta$ 1-532-746-11	FUSE, GLASS TUBE (4A/125V)					
	$\Delta$ 1-543-653-21	CORE ASSY, BEAD (DIVISION TYPE)					
	$\Delta$ 1-551-812-11	CORD, POWER (7A/125V) (14E1U/14E5U/14F1U/14F5U/20E1F/20F1U)					
	$\Delta$ 1-576-230-31	FUSE (H.B.C) (T3.15A/250V)					
	$\Delta$ 1-590-151-11	CORD SET, POWER (14E1E/14E5E/14F1E/14F5E/20E1E/20F1E)					
	3-170-078-01	HOLDR (B), PLUG					
	*3-704-334-01	SHEET (STANDARD), PROTECTION (BKM-10R)					
	3-800-958-02	MANUAL, OPERATION (14E1E/14E1U/14F1E/14F1U/20E1E/20E1U/20F1E/20F1U)					
	3-800-959-02	MANUAL, OPERATION (BKM-10R) (JAPANESE/ENGLISH)					
	3-800-993-12	MANUAL, OPERATION (14E5E/14E5U/14F5E/14F5U)					
	*4-051-298-02	CUSHION (UPPER) (ASSY) (20E1E/20E1U/20F1E/20F1U)					
	*4-051-299-02	CUSHION (LOWER) (ASSY) (20E1E/20E1U/20F1E/20F1U)					

The material contained in this manual consists of information that is the property of Sony Corporation and is intended solely for use by the purchasers of the equipment described in this manual.

Sony Corporation expressly prohibits the duplication of any portion of this manual or the use thereof for any purpose other than the operation or maintenance of the equipment described in this manual without the express written permission of Sony Corporation.

Le matériel contenu dans ce manuel consiste en informations qui sont la propriété de Sony Corporation et sont destinées exclusivement à l'usage des acquéreurs de l'équipement décrit dans ce manuel.

Sony Corporation interdit formellement la copie de quelque partie que ce soit de ce manuel ou son emploi pour tout autre but que des opérations ou entretiens de l'équipement à moins d'une permission écrite de Sony Corporation.

Das in dieser Anleitung enthaltene Material besteht aus Informationen, die Eigentum der Sony Corporation sind, und ausschließlich zum Gebrauch durch den Käufer der in dieser Anleitung beschriebenen Ausrüstung bestimmt sind. Die Sony Corporation untersagt ausdrücklich die Vervielfältigung jeglicher Teile dieser Anleitung oder den Gebrauch derselben für irgendeinen anderen Zweck als die Bedienung oder Wartung der in dieser Anleitung beschriebenen Ausrüstung ohne ausdrückliche schriftliche Erlaubnis der Sony Corporation.

