

# SERVICE MANUAL

# S MIC CHASSIS

<i>MODEL</i> .....	<i>DEST.</i> .....	<i>CHASSIS NO.</i> .....	<i>MODEL</i> .....	<i>DEST.</i> .....	<i>CHASSIS NO.</i> .....
<i>PVM-8042Q</i>	<i>US/CND</i>	<i>SCC-E96H-A</i>	<i>PVM-9042QM</i>	<i>AEP</i>	<i>SCC-F09H-A</i>
<i>PVM-8045Q</i>	<i>US/CND</i>	<i>SCC-E96J-A</i>	<i>PVM-9042QM</i>	<i>AUS</i>	<i>SCC-F90F-A</i>
			<i>PVM-9045QM</i>	<i>AEP</i>	<i>SCC-F09J-A</i>
			<i>PVM-9045QM</i>	<i>AUS</i>	<i>SCC-F90G-A</i>
			<i>PVM-9045PM</i>	<i>BRZ</i>	<i>SCC-F31B-A</i>

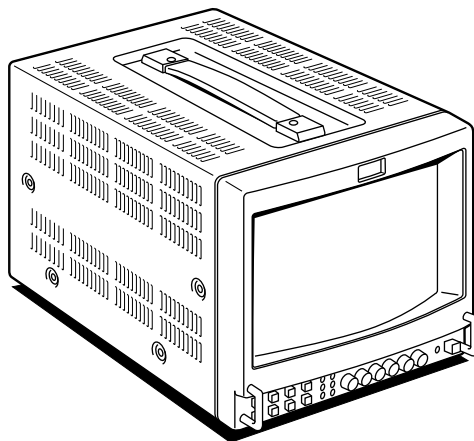

TRINITRON® COLOR VIDEO MONITOR

**SONY**®

## **⚠ WARNING**

This manual is intended for qualified service personnel only.

To reduce the risk of electric shock, fire or injury, do not perform any servicing other than that contained in the operating instructions unless you are qualified to do so. Refer all servicing to qualified service personnel.

### **WARNING!!**

**AN ISOLATION TRANSFORMER SHOULD BE USED DURING ANY SERVICE TO AVOID POSSIBLE SHOCK HAZARD, BECAUSE OF LIVE CHASSIS.**

**THE CHASSIS OF THIS RECEIVER IS DIRECTLY CONNECTED TO THE AC POWER LINE.**

### **SAFETY-RELATED COMPONENT WARNING!!**

**COMPONENTS IDENTIFIED BY MARK ⚠ ON THE SCHEMATIC DIAGRAMS, EXPLODED VIEWS AND IN THE PARTS LIST ARE CRITICAL TO SAFE OPERATION. REPLACE THESE COMPONENTS WITH SONY PARTS WHOSE PART NUMBERS APPEAR AS SHOWN IN THIS MANUAL OR IN SUPPLEMENTS PUBLISHED BY SONY. CIRCUIT ADJUSTMENTS THAT ARE CRITICAL TO SAFE OPERATION ARE IDENTIFIED IN THIS MANUAL. FOLLOW THESE PROCEDURES WHENEVER CRITICAL COMPONENTS ARE REPLACED OR IMPROPER OPERATION IS SUSPECTED.**

### **ATTENTION!!**

**AFIN D'EVITER TOUT RISQUE D'ELECTROCUTION PROVENANT D'UN CHÂSSIS SOUS TENSION, UN TRANSFORMATEUR D'ISOLEMENT DOIT ETRE UTILISÉ LORS DE TOUT DÉPANNAGE. LE CHÂSSIS DE CE RÉCEPTEUR EST DIRECTEMENT RACCORDÉ À L'ALIMENTATION SECTEUR.**

### **ATTENTION AUX COMPOSANTS RELATIFS À LA SÉCURITÉ!!**

**LES COMPOSANTS IDENTIFIÉS PAR UNE TRAME ET PAR UNE MARQUE ⚠ SUR LES SCHÉMAS DE PRINCIPE, LES VUES EXPLOSÉES ET LES LISTES DE PIÈCES CONT D'UNE IMPORTANCE CRITIQUE PUR LA SÉCURITÉ DU FONCTIONNEMENT. NE LES REMPLACER QUE PAR DES COMPOSANTS SONY DONT LE NUMÉRO DE PIÈCE EST INDIQUÉ DANS LE PRÉSENT MANUEL OU DANS DES SUPPLÉMENTS PUBLIÉS PAR SONY. LES RÉGLAGES DE CIRCUIT DONT L'IMPORTANCE EST CRITIQUE POUR LA SÉCURITÉ DU FONCTIONNEMENT SONT IDENTIFIÉS DANS LE PRÉSENT MANUEL. SUIVRE CES PROCÉDURES LORS DE CHAQUE REMPLACEMENT DE COMPOSANTS CRITIQUES, OU LORSQU'UN MAUVAIS FONCTIONNEMENT EST SUSPECTÉ.**

# TABLE OF CONTENTS

## 1. OPERATING INSTRUCTIONS

## 2. SERVICE INFORMATION

2-1. CIRCUIT BOARDS LOCATION .....	2-1
2-2. DISASSEMBLY .....	2-2
2-2-1. Cabinet Removal .....	2-2
2-2-2. B Board Removal .....	2-2
2-2-3. Switching Regulator Removal .....	2-3
2-2-4. D Board Removal .....	2-3
2-2-5. P Board Removal .....	2-4
2-2-6. Rear Assembly Removal .....	2-4
2-2-7. HA Board Removal .....	2-5
2-2-8. CRT Removal .....	2-5
2-2-9. Removal of Anode-cap .....	2-6
2-2-10. Equipment Required .....	2-7

## 3. SET-UP ADJUSTMENTS

3-1. PREPARATIONS .....	3-1
3-2. LANDING ADJUSTMENT .....	3-2
3-2-1. Preparations .....	3-2
3-2-2. Landing Adjustment .....	3-2
3-3. CONVERGENCE ADJUSTMENT .....	3-3
3-3-1. Horizontal and Vertical Convergence Adjustment on the Center of Screen .....	3-3
3-3-2. Horizontal and Vertical Dynamic Convergence Adjustment in the Vicinity of Screen .....	3-4
3-4. FOCUS ADJUSTMENT .....	3-5
3-5. WHITE BALANCE ADJUSTMENT .....	3-5
3-5-1. Screen Voltage Adjustment .....	3-5
3-5-2. White Balance Adjustment .....	3-5

## 4. SAFETY RELATED ADJUSTMENTS

4-1. B+ VOLTAGE CHECK .....	4-1
4-1-1. B+ Voltage Check in AC Operation .....	4-1
4-1-2. B+ Voltage Check in DC Operation .....	4-2
4-2. PROTECTION CIRCUIT (HOLD-DOWN CIRCUIT) CHECK .....	4-2
4-2-1. Shutdown Voltage Adjustment .....	4-2
4-2-2. Protection Circuit Operation Check .....	4-2

## 5. CIRCUIT ADJUSTMENTS

5-1. D BOARD ADJUSTMENTS .....	5-1
5-1-1. Horizontal Oscillating Frequency Adjustment (RV503) .....	5-1
5-1-2. Video Phase Adjustment (RV512, RV516, RV502) .....	5-1
5-1-3. Vertical Blanking Adjustment (RV501) .....	5-2
5-1-4. Horizontal Blanking Adjustment (RV516) .....	5-2
5-1-5. Vertical Deflection System Adjustment (RV505, RV507, RV504, RV518) .....	5-2
5-1-6. Horizontal Deflection System Adjustment (RV508, RV509, RV511, RV514, RV515, and RV801/P Board) .....	5-3
5-1-7. Under Scan Adjustment (RV517, RV512) .....	5-3
5-1-8. Horizontal/Vertical Delay Adjustment (RV832, RV831) .....	5-3
5-2. B BOARD ADJUSTMENTS .....	5-4
5-2-1. Primary Color Matrix Adjustment (1) (RV115) .....	5-4
5-2-2. Primary Color Matrix Adjustment (2) (RV116, RV123) .....	5-4
5-2-3. Burst Gate Pulse Width Adjustment (RV109) .....	5-5
5-2-4. NTSC Subcarrier Frequency Adjustment (RV1400) .....	5-5
5-2-5. PAL Subcarrier Frequency Adjustment (RV1401) .....	5-5
5-2-6. NTSC Comb Filter Adjustment (RV1, T1/CFM101) .....	5-5
5-2-7. NTSC 3.58 MHz Color Demodulation (B-Y) Adjustment (RV114, RV111) .....	5-6
5-2-8. NTSC 3.58 MHz Color Demodulation (R-Y) Adjustment (RV104, RV107) .....	5-6
5-2-9. NTSC 4.43 MHz Color Demodulation Adjustment (RV108, RV112) ..	5-6
5-2-10. PAL Color Demodulation Adjustment (RV113, RV2/SEP101, RV110, RV105) .....	5-7
5-2-11. Sub-Sharpness Adjustment (RV205) .....	5-7
5-2-12. Chroma H Pulse Adjustment (RV101, RV102) .....	5-7
5-3. S BOARD ADJUSTMENTS .....	5-8
5-3-1. SECAM Bell Filter Adjustment (T1101) .....	5-8
5-3-2. SECAM Color Balance Adjustment (L1102, L1103) .....	5-8
5-3-3. SECAM Demodulation Level Adjustment (RV1101, RV1102) .....	5-8

## 6. SEMICONDUCTORS

## 7. EXPLODED VIEWS

7-1. CHASSIS .....	7-1
7-2. PICTURE TUBE .....	7-2

## 8. ELECTRICAL PARTS LIST



## 9. BLOCK DIAGRAMS

QA (1/2) .....	9-1
HA .....	9-1
X .....	9-1
B .....	9-2
S .....	9-4
QA (2/2) .....	9-4
FA .....	9-4
G .....	9-4
D .....	9-5
CA .....	9-6
P .....	9-6
PA .....	9-6

## 10. DIAGRAMS

10-1. FRAME SCHEMATIC DIAGRAMS .....	10-2
10-2. SCHEMATIC DIAGRAMS/PRINTED WIRING BOARDS .....	10-4
SCHEMATIC DIAGRAMS	
G Board .....	10-4
QA Board .....	10-5
FA Board .....	10-7
D (1/2) Board .....	10-9
D (2/2) Board .....	10-10
P Board .....	10-11
B (1/3) Board .....	10-15
B (2/3) Board .....	10-17
B (3/3) Board .....	10-19
S Board .....	10-20
HA Board .....	10-21
PA Board .....	10-21
CA Board .....	10-22
X Board .....	10-22
PRINTED WIRING BOARDS	
G Board .....	10-4
QA Board .....	10-5
D Board .....	10-6
FA Board .....	10-7
P Board .....	10-11
B Board .....	10-12
S Board .....	10-20
HA Board .....	10-21
PA Board .....	10-21
CA Board .....	10-22
X Board .....	10-22



**SONY**

3-865-058-11 (1)

# *Trinitron® Color Video Monitor*

Operating Instructions_____	<b>US</b>
Mode d'emploi_____	<b>FR</b>
Manual de instrucciones_____	<b>ES</b>

## SECTION 1 OPERATING INSTRUCTIONS



**PVM-8045Q**

**Trinitron**

**PVM-8042Q  
PVM-8040**

© 1998 by Sony Corporation

This section is extracted  
from operating instructions.

English

**WARNING**

To prevent fire or shock hazard, do not expose the unit to rain or moisture.

Dangerously high voltages are present inside the unit. Do not open the cabinet. Refer servicing to qualified personnel only.

THIS APPARATUS MUST BE EARTHED



This symbol is intended to alert the user to the presence of uninsulated "dangerous voltage" within the product's enclosure that may be of sufficient magnitude to constitute a risk of electric shock to persons.



This symbol is intended to alert the user to the presence of important operating and maintenance (servicing) instructions in the literature accompanying the appliance.

**For the customers in the USA**

This equipment has been tested and found to comply with the limits for a Class A digital device, pursuant to Part 15 of the FCC Rules. These limits are designed to provide reasonable protection against harmful interference when the equipment is operated in a commercial environment. This equipment generates, uses, and can radiate radio frequency energy and, if not installed and used in accordance with the instruction manual, may cause harmful interference to radio communications. Operation of this equipment in a residential area is likely to cause harmful interference in which case the user will be required to correct the interference at his own expense.

You are cautioned that any changes or modifications not expressly approved in this manual could void your authority to operate this equipment.

2 (US)

In the event of a malfunction or when maintenance is necessary, consult an authorized Sony dealer.

Ensure that your equipment is connected correctly. If you are in any doubt consult a qualified electrician.

**CAUTION:**

Danger of explosion if battery is incorrectly replaced. Replace only with the same or equivalent type recommended by the manufacturer. Discard used batteries according to the manufacturer's instructions.

**Precautions****On safety**

- **PVM-8045Q/8042Q:** Operate the unit on 120 V AC or 12 V DC. For the AC operation, use only the supplied AC power cord or the AC power adaptor recommended (not supplied). Do not use any other type. For the battery operation, use only the NP-1B battery pack and BP-L60A/L90A with DC-L10 (not supplied). Do not use any other batteries.
- **PVM-8040:** Operate the unit only on 120 V AC. Use only the supplied AC power cord. Do not use any other type.
- Should any liquid or solid object fall into the cabinet, unplug the unit and have it checked by qualified personnel before operating it further.
- Unplug the unit from the wall outlet if it is not to be used for several days.
- To disconnect the AC power cord, pull it out by the plug. Never pull the cord itself.

**On installation**

- Allow adequate air circulation to prevent internal heat build-up. Do not place the unit on surfaces (rugs, blankets, etc.) or near materials (curtains, draperies) that may block the ventilation holes.
- Do not install the unit near heat sources such as radiators or air ducts, or in a place subject to direct sunlight, excessive dust, mechanical vibration or shock.
- Keep the unit away from a loudspeaker or motor, as the picture may be affected.

**On cleaning**

Clean the unit with a slightly dampened soft cloth. Use a mild household detergent. Never use strong solvents such as thinner or benzene as they might damage the finish of the cabinet. As a safety precaution, unplug the unit before cleaning it.

**On repacking**

Retain the original carton and packing materials for safe transport of this unit in the future.

If you have any questions about this unit, contact your authorized Sony dealer.

**ATTENTION – When the product is installed in a rack:**

- Elevated operating ambient temperature**  
If installed in a closed or multi-unit rack assembly, the operating ambient temperature of the rack environment may be greater than room ambient. Therefore, consideration should be given to installing the equipment in an environment compatible with the manufacturer's maximum rated ambient temperature of 0 to +35°C (32 to 95°F) (Tmra).
- Reduced air flow**  
Installation of the equipment in a rack should be such that the amount of air flow required for safe operation of the equipment is not compromised.
- Mechanical loading**  
Mounting of the equipment in the rack should be such that a hazardous condition is not achieved due to uneven mechanical loading.
- Circuit overloading**  
Consideration should be given to the connection of the equipment to the supply circuit and the effect that overloading of circuits might have on overcurrent protection and supply wiring. Appropriate consideration of equipment nameplate ratings should be used when addressing this concern.
- Reliable earthing**  
Reliable earthing of rack-mounted equipment should be maintained. Particular attention should be given to supply connections other than direct connections to the branch circuit (e.g., use of power strips).
- Gap keeping**  
The upper and lower gaps of rack-mounted equipment should be least 44 mm (1 7/8 inches).

3 (US)

## Table of Contents

Features.....	5
Location and function of parts and controls .....	6
Front .....	6
Rear .....	8
Power sources .....	10
Specifications .....	11

This instruction manual covers the PVM-8045Q, PVM-8042Q and PVM-8040. The differences among the models are clearly described in the text.

### PVM-8045Q/8042Q

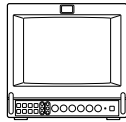

### PVM-8040

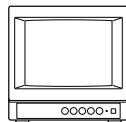

## Features

### Four color systems available (PVM-8045Q/8042Q only)

The monitor can display NTSC, PAL, SECAM and NTSC4.43<sup>1)</sup> signals. The appropriate color system is selected automatically.

### HR (High Resolution) Trinitron<sup>®2)</sup> picture tube (PVM-8045Q)

The HR Trinitron picture tube (0.25 mm aperture grill pitch) provides a high resolution picture. Horizontal resolution is more than 450 TV lines at the center of the picture.

### Trinitron picture tube (PVM-8042Q/8040)

The Trinitron picture tube (0.5mm aperture grill pitch) provides a high resolution picture. Horizontal resolution is more than 250 TV lines at the center of the picture.

### Beam current feedback circuit

The built-in beam current feedback circuit assures stable white balance.

### Comb filter

When NTSC video signals are received, a comb filter activates to increase the resolution, resulting fine picture detail without color spill or color noise.

### Multiple input signals (PVM-8045Q/8042Q only)

In addition to the composite video signals and the Y/C signals, analog RGB signals and component signals can be input.

### External sync input (PVM-8045Q/8042Q only)

When the EXT SYNC button is pressed, the monitor can be operated on the sync signal fed through an external sync connector.

### Blue only picture (PVM-8045Q/8042Q only)

Black and white apparent picture consisting from only the blue signal will be displayed. This facilitates the "chroma" and "phase" adjustment, and the observation of the video noise.

### 16:9 selector (PVM-8045Q/8042Q only)

The monitor can display the 16:9 signal with the correct ratio of width and height, compressing the picture vertically.

### Under scan mode (PVM-8045Q/8042Q only)

The monitor can display signals that are scanned outside the normal screen so you can monitor the whole image.

### Audio circuit and built-in speaker

A speaker (0.5 W, monaural) is built into the monitor for sound monitoring.

### Automatic/Manual DEGAUSS

The screen is automatically demagnetized when the monitor is turned on. Manual degauss is also available for PVM-8045Q/8042Q by pressing the DEGAUSS button.

### Automatic termination

(only connectors marked  $\sim$ )  
The Y/C, VIDEO IN and EXT SYNC IN connectors are terminated at 75 ohms inside, when no cable is connected to the loop-through output connectors. When a cable is connected to an output connector, the 75-ohm termination is automatically released.

### EIA standard 19-inch rack mounting

By using an MB-507 mounting bracket (not supplied), the monitor can be mounted in an EIA standard 19-inch rack. For details on mounting, see the instruction manual of the MB-507.

### Varied power sources

In addition to AC power, you can use battery pack or external DC 12 V power. The monitor can operate with one or two Sony NP-1B\* battery packs. If you use the DC-L10\* battery adaptor, the monitor can operate with a Sony BP-L60A/L90A\* lithium ion battery pack.

\* The NP-1B battery pack, DC-L10 battery adaptor and BP-L60A/L90A battery pack are not supplied.

1) An NTSC 4.43 signal is used for playing back NTSC-recorded video cassettes with a video tape recorder/player especially designed for use with this system.

2) Trinitron is a trademark of Sony Corporation.

## Location and Function of Parts and Controls

### Front

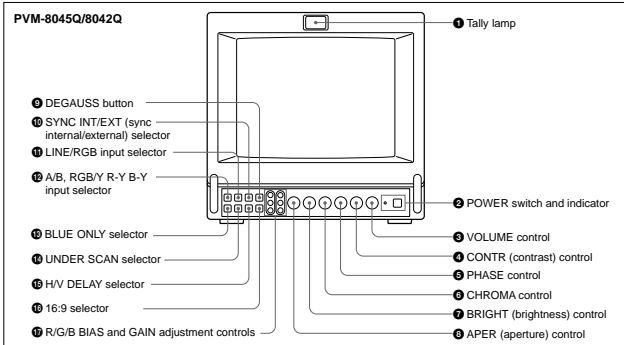

#### 1 Tally lamp

This indicator lights up. The tally control connection is needed.

For the pin assignment, see "Specifications" on page 12 (US).

#### 2 POWER switch and indicator

Depress to turn the monitor on. The indicator will light up in green. The POWER indicator also functions as the battery indicator. When the internal battery becomes weak or the power supplied through the DC 12 V IN jack decreases, the indicator flashes.

#### 3 VOLUME control

Turn this control clockwise or counterclockwise to obtain the desired volume.

#### 4 CONTR (contrast) control

Turn clockwise to make the contrast stronger and counterclockwise to make it weaker.

#### 5 PHASE control

This control is effective only for the NTSC and NTSC4.43 color systems. Turn clockwise to make the skin tones greenish and counterclockwise to make them purplish.

6 (US)

#### 6 CHROMA control

Turn clockwise to make the colour intensity stronger and counterclockwise to make it weaker.

#### 7 BRIGHT (brightness) control

Turn clockwise for more brightness and counterclockwise for less.

#### 8 APER (aperture) control

Turn clockwise for more sharpness and counterclockwise for less.

#### Notes

- The PHASE, CHROMA and APER control settings have no effect on an analog RGB signal.
- The PHASE control has no effect on component signals.
- The PHASE control setting is effective only for the NTSC system.

#### 9 DEGAUSS button

Press this button momentarily. The screen will be demagnetized.

#### Note

If you press the DEGAUSS button again too soon, the color shades may be uneven.

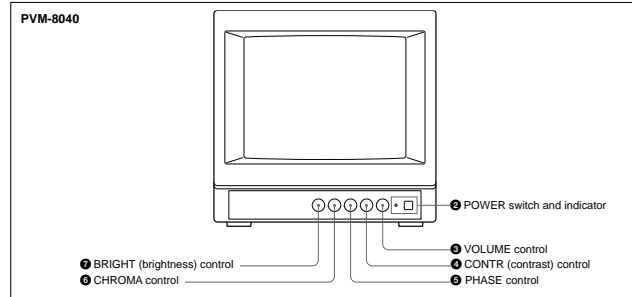

**1 SYNC INT/EXT (sync internal/external) selector**  
Keep this button released (INT) to operate the monitor on the sync signal from the displayed composite video signal.

Depress this button (EXT) to operate the monitor on an external sync signal fed through the EXT SYNC connector on the rear panel.

#### 1 LINE/RGB input selector

Select the programme to be monitored. Keep this button released (LINE) for a signal fed through the LINE A or LINE B connectors. Depress this button (RGB) for a signal fed through the RGB connectors.

#### 2 A/B, RGB/Y R-Y B-Y input selector

When the LINE/RGB input selector is set to LINE, keep this button released (A) for a signal fed through the LINE A connectors. Press this button (B) to monitor the signals from the LINE B connector.

When the LINE/RGB input selector is set to RGB, select the RGB signal or the component signal which is fed through the RGB input connectors. Keep this button released (RGB) for the RGB signal. Press this button (Y R-Y B-Y) to monitor the component signals.

#### 3 BLUE ONLY selector

Depress this button to turn off the red and green signals. A blue signal is displayed as an apparent monochrome picture on the screen. This facilitates "chroma" and "phase" control adjustments and the observation of video noise.

#### Note

The PHASE control adjustments is effective only for the NTSC system.

#### 4 UNDER SCAN selector

Depress this button for underscanning. The display size is reduced by approximately 3% so that four corners of the picture are visible.

#### 5 H/V DELAY selector

Depress this button to observe the horizontal and vertical sync signals at the same time. The horizontal sync signal is displayed in the left quarter of the screen; the vertical sync signal is displayed near the center of the screen.

#### 6 16:9 selector

Press this selector to monitor the signals of 16:9 picture.

Pressing the UNDER SCAN selector 4 in 16:9 mode displays the whole 16:9 picture up to the four corners.

#### 7 R/G/B BIAS and GAIN adjustment controls

Used for white balance fine adjustment. BIAS and GAIN controls are provided for the R (red), G (green) and B (blue) screens.

**BIAS:** Adjust the white balance and brightness of the screen at the lowlight.

**GAIN:** Adjust the white balance and brightness of the screen at the highlight.

7 (US)

## Location and Function of Parts and Controls

### Rear

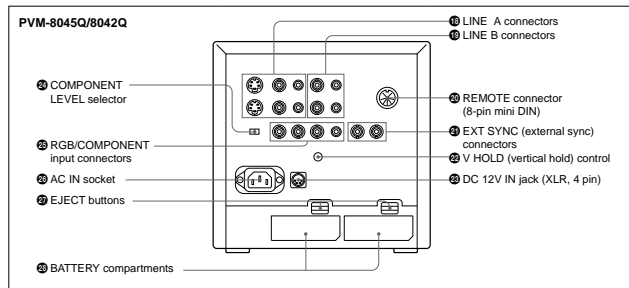

#### 1 LINE A connectors (PVM-8045Q/8042Q)

#### 2 LINE B connectors (PVM-8040)

**Y/C IN (4-pin mini DIN):** Connect to the Y/C separate output of a video camera, VCR or other video equipment.

**Y/C OUT (4-pin mini DIN):** Loop-through output of the Y/C IN connector. Connect to the Y/C separate input of a VCR or another monitor.

**VIDEO IN (BNC):** Connect to the video output of a video camera, VCR or other video equipment.

**VIDEO OUT (BNC):** Loop-through output of the VIDEO IN connector. Connect to the video input of a VCR or another monitor.

**AUDIO IN (phono jack):** Connect to the audio output of a VCR or a microphone (through a suitable microphone amplifier).

**AUDIO OUT (phono jack):** Loop-through output of the AUDIO IN connector. Connect to the audio input of a VCR or another monitor.

#### Note

The Y/C IN connector has a priority over the VIDEO IN connector.

When a plug is connected to the Y/C IN connector, the VIDEO IN connector is automatically disconnected.

#### Note

(PVM-8045Q/8042Q only)

To monitor the signal fed through these connectors, keep the LINE/RGB selector and the A/B, RGB/Y R-Y B-Y selector on the front panel released (LINE and A).

#### 3 REMOTE connector (8-pin mini DIN)

To monitor the signal fed through these connectors, keep the LINE/RGB selector released (LINE) and depress the A/B, RGB/Y R-Y B-Y selector on the front panel (B).

**VIDEO IN (BNC):** Connect to the video output of a video camera, VCR or other video equipment.

**VIDEO OUT (BNC):** Loop-through output of the VIDEO IN connector. Connect to the video input of a VCR or another monitor.

**AUDIO IN (phono jack):** Connect to the audio output of a VCR or a microphone (through a suitable microphone amplifier).

**AUDIO OUT (phono jack):** Loop-through output of the AUDIO IN connector. Connect to the audio input of a VCR or another monitor.

#### 4 EXT SYNC (external sync) connectors

Connect to the tally output of a control console, special-effect generator, etc. The tally lamp on the front panel will be turned on and off by the connected equipment. This connector can be used for connecting a remote controller.

*For the pin assignment of this connector, see "Specifications" on page 12 (US).*

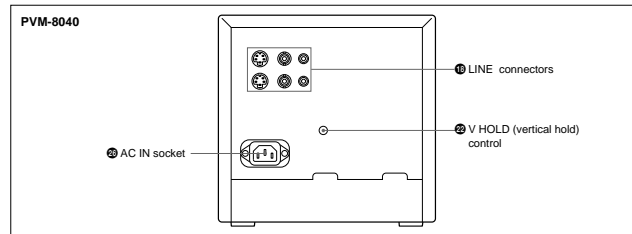

#### 4 EXT SYNC (external sync) connectors

**IN (BNC):** When this monitor operates on an external sync signal, connect the reference signal from a sync generator to this connector. In this case, depress the SYNC INT/EXT selector on the front panel (EXT).

**OUT (BNC):** Loop-through output of the EXT SYNC IN connector. Connect to the external sync input of video equipment to be synchronized with this monitor.

#### 5 V HOLD (vertical hold) control

Turn to stabilize the picture if it rolls vertically.

#### 6 DC 12V IN jack (XLR, 4 pin)

Connect the Sony battery adaptor DC-L10 (not supplied).

#### 7 COMPONENT LEVEL selector

Select the component level from among two modes.

**N10/SMPTTE:** for 100/0/100/0 signal

**BETA 0:** for 100/0/75/0 signal

#### 8 RGB/COMPONENT input connectors

**R/R-Y, G/Y, B/B-Y (BNC), AUDIO (phono):**

To monitor a signal fed through these connectors, depress the LINE/RGB selector on the front panel (RGB). When the SYNC INT/EXT selector on the front panel is released (INT), the monitor operates on the sync signal from the G/Y channel.

#### To monitor the analog RGB signal

Connect to the analog RGB signal outputs of a video camera. Keep the A/B, RGB/Y R-Y B-Y selector on the front panel released (RGB).

#### To monitor the component signal

Connect to the R-Y/Y-B-Y component signal outputs of a Sony BetaCam video camera. Depress the A/B, RGB/Y R-Y B-Y selector on the front panel (Y R-Y B-Y).

#### 9 AC IN socket

Connect the supplied AC power cord to this socket and to a wall outlet.

#### 10 EJECT buttons

Press the EJECT button upwards to remove the battery pack.

#### 11 BATTERY compartments

Insert the NP-1B battery pack (not supplied).

## Power Sources

### House Current (for all models)

Connect the supplied AC power cord to the AC IN socket and to a wall outlet.

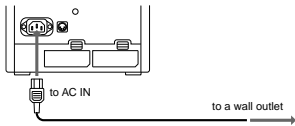

#### For the PVM-8045Q/8042Q

When the AC power cord is plugged into the AC IN socket, the battery pack (if installed) or the AC power adaptor (if connected) is automatically disconnected.

To connect an AC power cord securely with AC plug holders.

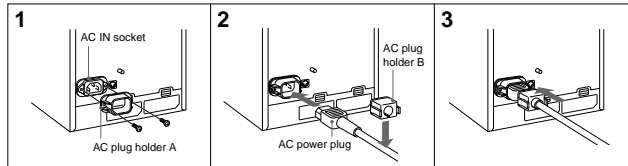

**1** Remove the AC IN socket screws and then use them to attach the AC plug holder A (supplied) to the AC IN socket.

**2** Plug the power cord to the AC IN socket. Then, attach the supplied AC plug holder B on top of the AC power cord.

**3** Slide AC plug holder B over the cord until it locks.

#### To remove the AC power cord

Pull out AC plug holder B by squeezing the left and right sides.

### Rechargeable Battery (PVM-8045Q/8042Q only)

The monitor can operate with one or two battery packs. For extended use, two battery packs are recommended.

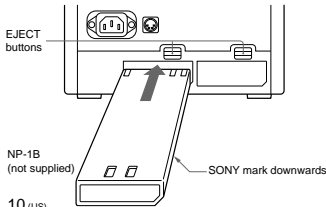

10 (us)

To remove the battery pack, press the EJECT button upwards.

For charging, use the BC-1WD for the NP-1B.

#### Note

Make sure you disconnect the cables connected to the connectors (AC IN, DC 12 V IN) at the rear of the monitor. Otherwise, the monitor cannot operate on the battery pack(s).

## Specifications

### Video signal

Colour system	PVM-8045Q/8042Q: NTSC, PAL, SECAM, NTSC4.43 PVM-8040: NTSC
Resolution	PVM-8045Q: 450 TV lines PVM-8042Q/8040: 250 TV lines
Aperture correction	-4.0 dB to +6.0 dB (at 3.0 MHz)
Frequency response	6.0 MHz (-3.0 dB) at all inputs
Synchronization	AFC time constant 1.0 msec.

### Picture performance

Normal scan	6% over scan of CRT effective screen area
Underscan	3% underscan of CRT effective screen area
H. linearity	Less than 5.0% (typical)
V. linearity	Less than 5.0% (typical)
Convergence	Central area: 0.43 mm (typical) Peripheral area: 0.53 mm (typical)
Raster size stability	H: 1.0%, V: 1.5%
High voltage regulation	3.0%
Color temperature	D65

### Inputs and Outputs

Connector	Model	PVM-8045Q PVM-8042Q	PVM-8040
LINE A	Y/C IN	yes	yes
	Y/C OUT	yes	yes
	VIDEO IN	yes	yes
	VIDEO OUT	yes	yes
	AUDIO IN AUDIO OUT	yes yes	yes yes
LINE B	VIDEO IN	yes	no
	VIDEO OUT	yes	no
	AUDIO IN AUDIO OUT	yes yes	no no
RGB/ COMPONENT	R/R-Y IN	yes	no
	G/Y IN	yes	no
	B/Y IN	yes	no
	AUDIO IN	yes	no
EXT SYNC	IN	yes	no
	OUT	yes	no
REMOTE		yes	no

### Inputs

Y/C IN: 4-pin mini DIN connector  
See the pin assignment on page 12 (US).  
VIDEO IN: BNC connector  
1 Vp-p  $\pm$  6 dB, sync negative  
AUDIO IN: phono jack, -5 dBu<sup>a</sup>, less than 47 kohms  
R/R-Y, G/Y, B/Y: BNC connector  
R, G, B channels: 0.7 Vp-p,  $\pm$  6 dB Sync on green: 0.3 Vp-p, negative,  
R-Y, Y, B-Y channels: 0.7 Vp-p,  $\pm$  6 dB (Standard colour bar signal of 75% chrominance)  
EXT SYNC IN: BNC connector  
Composite sync 4 Vp-p,  $\pm$  6 dB, negative

### Loop-through outputs

Y/C OUT: 4-pin mini DIN connector, 75 ohms terminated (75 ohms automatic termination)  
VIDEO OUT: BNC connector, 75 ohms terminated (75 ohms automatic termination)  
AUDIO OUT: phono jack  
EXT SYNC OUT: BNC connector, 75 ohms terminated  
Output level 0.5 W  
REMOTE: 8-pin mini DIN connector (75 ohms automatic termination)  
See the pin assignment on page 12 (US).

a) 0 dBu = 0.775 V<sub>r.m.s.</sub>

### General

Power consumption & requirements  
PVM-8045Q/8042Q:  
0.6 A 45 W MAX at 120 V AC operation  
3.7 A 38 W at 12 V DC operation  
PVM-8040:  
0.6 A 39 W MAX at 120 V AC operation

### Operating conditions

Temperature 0 to +35°C (32 to 95°F)  
Humidity 0 to 90% (no condensation)  
Pressure 700 to 1060 hPa

11 (us)



## Specifications

Transport and storage conditions	
Temperature	-10 to +40°C (14 to 104°F)
Humidity	0 to 90%
Pressure	700 to 1060 hPa
Dimensions	Approx. 217 x 217 x 352.5 mm (w/h/d) (8 5/8 x 8 5/8 x 14 inches) not incl. projecting parts and controls
Mass	Approx. 8.2 kg (18 lb 1 oz) not incl. battery packs
Accessory supplied	AC power cord (1) Cable with an 8-pin connector (1) (PVM-8045Q/8042Q only) AC plug holders (1 set) Tally plate (1) (PVM-8045Q/ 8042Q only)

Design and specifications are subject to change without notice.

### Pin Assignment

#### Y/C IN connector (4-pin mini DIN)



Pin No.	Signal	Description
1	Y-input	1 Vp-p, sync negative, 75 ohms
2	CHROMA	286 mVp-p (NTSC), burst sub-carrier-input Delay time between Y and C: within 0 ±100 nsec., 75 ohms
3	GND for Y-input	GND
4	GND for CHROMA-input	GND

#### REMOTE connector (8-pin mini DIN) (PVM-8045Q/8042Q only)



Pin No.	Signal
1	16:9
2	H/V delay
3	GND
4	EXT SYNC
5	Tally
6	Underscan
7	A/B or RGB/Y R-Y B-Y
8	LINE/RGB

#### Notes

- For remote control, connect the pin of the desired function to pin 3 (GND).
- For remote control, set the front button to OFF (the switch is out).

**SONY**

3-865-058-21 (1)

# *Trinitron<sup>®</sup> Color Video Monitor*

Operating Instructions _____	<b>GB</b>
Mode d'emploi _____	<b>FR</b>
Bedienungsanleitung _____	<b>DE</b>
Manual de instrucciones _____	<b>ES</b>
Istruzioni per l'uso _____	<b>IT</b>
使用说明书 _____	<b>CS</b>



Trinitron

**Trinitron**

**PVM-9045QM**

**PVM-9042QM**

**PVM-9040ME**

© 1998 by Sony Corporation

English

**WARNING**

To prevent fire or shock hazard, do not expose the unit to rain or moisture.

Dangerously high voltages are present inside the unit. Do not open the cabinet. Refer servicing to qualified personnel only.

In the event of a malfunction or when maintenance is necessary, consult an authorized Sony dealer.

**THIS APPARATUS MUST BE EARTHED**

For the customers in the UNITED KINGDOM

**IMPORTANT**

The wires in this mains lead are coloured in accordance with the following code:

Green-and-yellow	: Earth
Blue	: Neutral
Brown	: Live

As the colours of the wires in the mains lead of this apparatus may not correspond with the coloured markings identifying the terminals in your plug proceed as follows: The wire which is coloured green-and-yellow must be connected to the terminal in the plug which is marked with the letter E or by the safety earth symbol  or coloured green or green-and-yellow.

The wire which is coloured blue must be connected to the terminal which is marked with the letter N or coloured black. The wire which is coloured brown must be connected to the terminal which is marked with the letter L or coloured red.

Ensure that your equipment is connected correctly. If you are in any doubt consult a qualified electrician.

**CAUTION:**

Danger of explosion if battery is incorrectly replaced. Replace only with the same or equivalent type recommended by the manufacturer. Discard used batteries according to the manufacturer's instructions.

Voor de klanten in Nederland



Bij dit produkt zijn batterijen geleverd. Wanneer deze leeg zijn, moet u ze niet weggooien maar inleveren als KCA.

**Precautions****On safety**

- **PVM-9045QM/9042QM:** Operate the unit on 100 - 240 V AC or 12 V DC. For the AC operation, use only the supplied AC power cord or the AC power adaptor recommended (not supplied). Do not use any other type. For the battery operation, use only the NP-1B battery pack and BP-L60A/L90A with DC-L10 (not supplied). Do not use any other batteries.
- **PVM-9040ME:** Operate the unit only on 100 - 240 V AC. Use only the supplied AC power cord. Do not use any other type.
- Should any liquid or solid object fall into the cabinet, unplug the unit and have it checked by qualified personnel before operating it further.
- Unplug the unit from the wall outlet if it is not to be used for several days.
- To disconnect the AC power cord, pull it out by the plug. Never pull the cord itself.

**On installation**

- Allow adequate air circulation to prevent internal heat build-up. Do not place the unit on surfaces (rugs, blankets, etc.) or near materials (curtains, draperies) that may block the ventilation holes.
- Do not install the unit near heat sources such as radiators or air ducts, or in a place subject to direct sunlight, excessive dust, mechanical vibration or shock.
- Keep the unit away from a loudspeaker or motor, as the picture may be affected.

**On cleaning**

Clean the unit with a slightly dampened soft cloth. Use a mild household detergent. Never use strong solvents such as thinner or benzene as they might damage the finish of the cabinet. As a safety precaution, unplug the unit before cleaning it.

**On repacking**

Retain the original carton and packing materials for safe transport of this unit in the future.

If you have any questions about this unit, contact your authorized Sony dealer.

**ATTENTION – When the product is installed in a rack:**

- Elevated operating ambient temperature**  
If installed in a closed or multi-unit rack assembly, the operating ambient temperature of the rack environment may be greater than room ambient. Therefore, consideration should be given to installing the equipment in an environment compatible with the manufacturer's maximum rated ambient temperature of 0 to +35°C (32 to 95°F) (Tmra).
- Reduced air flow**  
Installation of the equipment in a rack should be such that the amount of air flow required for safe operation of the equipment is not compromised.
- Mechanical loading**  
Mounting of the equipment in the rack should be such that a hazardous condition is not achieved due to uneven mechanical loading.
- Circuit overloading**  
Consideration should be given to the connection of the equipment to the supply circuit and the effect that overloading of circuits might have on overcurrent protection and supply wiring. Appropriate consideration of equipment nameplate ratings should be used when addressing this concern.
- Reliable earthing**  
Reliable earthing of rack-mounted equipment should be maintained. Particular attention should be given to supply connections other than direct connections to the branch circuit (e.g., use of power strips).
- Gap keeping**  
The upper and lower gaps of rack-mounted equipment should be least 44 mm (1 7/8 inches).

## Table of Contents

Features .....	5
Location and function of parts and controls .....	6
Front .....	6
Rear .....	8
Power sources .....	10
Specifications .....	11

This instruction manual covers the PVM-9045QM, PVM-9042QM and PVM-9040ME. The differences among the models are clearly described in the text.

### PVM-9045QM/9042QM



### PVM-9040ME

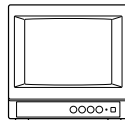

## Features

### Four colour systems available (PVM-9045QM/9042QM only)

The monitor can display PAL, SECAM, NTSC and NTSC4.43<sup>1)</sup> signals. The appropriate colour system is selected automatically.

### HR (High Resolution) Trinitron<sup>®2)</sup> picture tube (PVM-9045QM)

The HR Trinitron picture tube (0.25 mm aperture grill pitch) provides a high resolution picture. Horizontal resolution is more than 450 TV lines at the center of the picture.

**Trinitron picture tube (PVM-9042QM/9040ME)**  
The Trinitron picture tube (0.5mm aperture grill pitch) provides a high resolution picture. Horizontal resolution is more than 250 TV lines at the center of the picture.

### Beam current feedback circuit

The built-in beam current feedback circuit assures stable white balance.

### Multiple input signals (PVM-9045QM/9042QM only)

In addition to the composite video signals and the Y/C signals, analog RGB signals and component signals can be input.

### External sync input (PVM-9045QM/9042QM only)

When the EXT SYNC button is pressed, the monitor can be operated on the sync signal fed through an external sync connector.

### Blue only picture (PVM-9045QM/9042QM only)

Black and white apparent picture consisting from only the blue signal will be displayed. This facilitates the chroma adjustment, and the observation of the video noise.

### 16:9 selector (PVM-9045QM/9042QM only)

The monitor can display the 16:9 signal with the correct ratio of width and height, compressing the picture vertically.

### Under scan mode (PVM-9045QM/9042QM only)

The monitor can display signals that are scanned outside the normal screen so you can monitor the whole image.

### Audio circuit and built-in speaker

A speaker (0.5 W, monaural) is built into the monitor for sound monitoring.

### Automatic/Manual DEGAUSS

The screen is automatically demagnetized when the monitor is turned on. Manual degauss is also available for PVM-9045QM/9042QM by pressing the DEGAUSS button.

### Automatic termination

(only connectors marked  $\checkmark$ )  
The Y/C, VIDEO IN and EXT SYNC IN connectors are terminated at 75 ohms inside, when no cable is connected to the loop-through output connectors. When a cable is connected to an output connector, the 75-ohm termination is automatically released.

### EIA standard 19-inch rack mounting

By using an MB-507 mounting bracket (not supplied), the monitor can be mounted in an EIA standard 19-inch rack. For details on mounting, see the instruction manual of the MB-507.

### Varied power sources

In addition to AC power, you can use battery pack or external DC 12 V power. The monitor can operate with one or two Sony NP-1B\* battery packs. If you use the DC-L10\* battery adaptor, the monitor can operate with a Sony BP-L60A/L90A\* lithium ion battery pack.

\* The NP-1B battery pack, DC-L10 battery adaptor and BP-L60A/L90A battery pack are not supplied.

1) An NTSC 4.43 signal is used for playing back NTSC-recorded video cassettes with a video tape recorder/player especially designed for use with this system.

2) Trinitron is a trademark of Sony Corporation.

## Location and Function of Parts and Controls

### Front

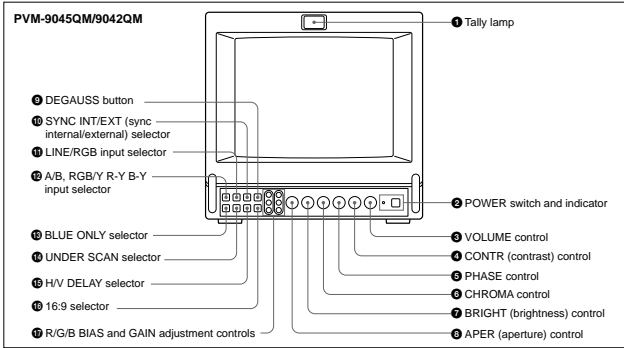

#### 1 Tally lamp

This indicator lights up. The tally control connection is needed.  
For the pin assignment, see "Specifications" on page 12 (GB).

#### 2 POWER switch and indicator

Depress to turn the monitor on. The indicator will light up in green.  
The POWER indicator also functions as the battery indicator. When the internal battery becomes weak or the power supplied through the DC 12 V IN jack decreases, the indicator flashes.

#### 3 VOLUME control

Turn this control clockwise or counterclockwise to obtain the desired volume.

#### 4 CONTR (contrast) control

Turn clockwise to make the contrast stronger and counterclockwise to make it weaker.

#### 5 PHASE control

This control is effective only for the NTSC and NTSC4.43 colour systems. Turn clockwise to make the skin tones greenish and counterclockwise to make them purplish.

#### 6 CHROMA control

Turn clockwise to make the colour intensity stronger and counterclockwise to make it weaker.

#### 7 BRIGHT (brightness) control

Turn clockwise for more brightness and counterclockwise for less.

#### 8 APER (aperture) control

Turn clockwise for more sharpness and counterclockwise for less.

#### Notes

- The PHASE, CHROMA and APER control settings have no effect on an analog RGB signal.
- The PHASE control has no effect on component signals.
- The PHASE control setting is effective only for the NTSC system.

#### 9 DEGAUSS button

Press this button momentarily. The screen will be demagnetized.

#### Note

If you press the DEGAUSS button again too soon, the color shades may be uneven.

6 (GB)

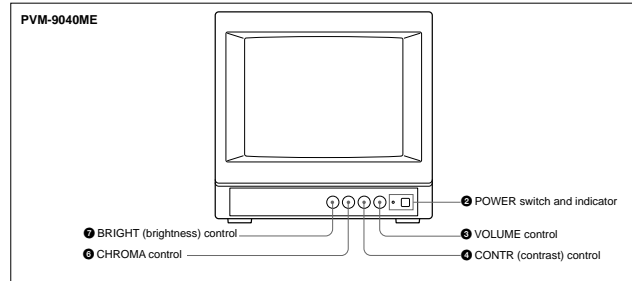

#### 1 SYNC INT/EXT (sync internal/external) selector

Keep this button released (INT) to operate the monitor on the sync signal from the displayed composite video signal.  
Depress this button (EXT) to operate the monitor on an external sync signal fed through the EXT SYNC connector on the rear panel.

#### 2 LINE/RGB input selector

Select the programme to be monitored. Keep this button released (LINE) for a signal fed through the LINE A or LINE B connectors. Depress this button (RGB) for a signal fed through the RGB connectors.

#### 3 A/B, RGB/Y R-Y B-Y input selector

When the LINE/RGB input selector is set to LINE, keep this button released (A) for a signal fed through the LINE A connectors. Press this button (B) to monitor the signals from the LINE B connectors.

When the LINE/RGB input selector is set to RGB, select the RGB signal or the component signal which is fed through the RGB input connectors. Keep this button released (RGB) for the RGB signal. Press this button (Y R-Y B-Y) to monitor the component signals.

#### 4 BLUE ONLY selector

Depress this button to turn off the red and green signals. A blue signal is displayed as an apparent monochrome picture on the screen. This facilitates "chroma" control adjustments and the observation of video noise.

#### 5 UNDER SCAN selector

Depress this button for underscanning. The display size is reduced by approximately 3% so that four corners of the picture are visible.

#### 6 H/V DELAY selector

Depress this button to observe the horizontal and vertical sync signals at the same time. The horizontal sync signal is displayed in the left quarter of the screen; the vertical sync signal is displayed near the center of the screen.

#### 7 16:9 selector

Press this selector to monitor the signals of 16:9 picture.  
Pressing the UNDER SCAN selector 5 in 16:9 mode displays the whole 16:9 picture up to the four corners.

#### 8 R/G/B BIAS and GAIN adjustment controls

Used for white balance fine adjustment. BIAS and GAIN controls are provided for the R (red), G (green) and B (blue) screens.

**BIAS:** Adjust the white balance and brightness of the screen at the low light.

**GAIN:** Adjust the white balance and brightness of the screen at the highlight.

7 (GB)

## Location and Function of Parts and Controls

### Rear

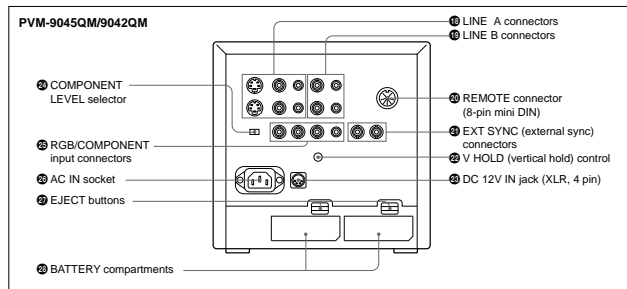

#### 11 LINE A connectors (PVM-9045QM/9042QM)

#### 10 LINE connectors (PVM-9040ME)

**Y/C IN (4-pin mini DIN):** Connect to the Y/C separate output of a video camera, VCR or other video equipment.

**Y/C OUT (4-pin mini DIN):** Loop-through output of the Y/C IN connector. Connect to the Y/C separate input of a VCR or another monitor.

**VIDEO IN (BNC):** Connect to the video output of a video camera, VCR or other video equipment.

**VIDEO OUT (BNC):** Loop-through output of the VIDEO IN connector. Connect to the video input of a VCR or another monitor.

**AUDIO IN (phono jack):** Connect to the audio output of a VCR or a microphone (through a suitable microphone amplifier).

**AUDIO OUT (phono jack):** Loop-through output of the AUDIO IN connector. Connect to the audio input of a VCR or another monitor.

#### Note

The Y/C IN connector has a priority over the VIDEO IN connector. When a plug is connected to the Y/C IN connector, the VIDEO IN connector is automatically disconnected.

#### Note

(PVM-9045QM/9042QM only)  
To monitor the signal fed through these connectors, keep the LINE/RGB selector and the A/B, RGB/Y R-Y B-Y selector on the front panel released (LINE and A).

#### 19 LINE B connectors

To monitor the signal fed through these connectors, keep the LINE/RGB selector released (LINE) and depress the A/B, RGB/Y R-Y B-Y selector on the front panel (B).

**VIDEO IN (BNC):** Connect to the video output of a video camera, VCR or other video equipment.

**VIDEO OUT (BNC):** Loop-through output of the VIDEO IN connector. Connect to the video input of a VCR or another monitor.

**AUDIO IN (phono jack):** Connect to the audio output of a VCR or a microphone (through a suitable microphone amplifier).

**AUDIO OUT (phono jack):** Loop-through output of the AUDIO IN connector. Connect to the audio input of a VCR or another monitor.

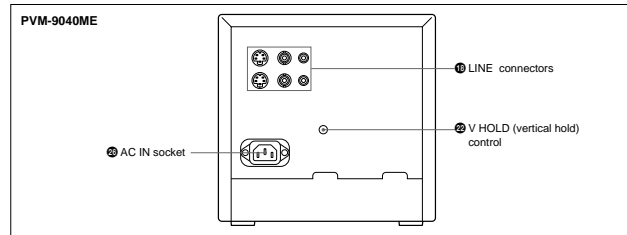

#### 4 REMOTE connector (8-pin mini DIN)

Connect to the tally output of a control console, special-effect generator, etc. The tally lamp on the front panel will be turned on and off by the connected equipment. This connector can be used for connecting a remote controller.

For the pin assignment of this connector, see "Specifications" on page 12 (GB).

#### 4 EXT SYNC (external sync) connectors

**IN (BNC):** When this monitor operates on an external sync signal, connect the reference signal from a sync generator to this connector. In this case, depress the SYNC INT/EXT selector on the front panel (EXT).

**OUT (BNC):** Loop-through output of the EXT SYNC IN connector. Connect to the external sync input of video equipment to be synchronized with this monitor.

#### 2 V HOLD (vertical hold) control

Turn to stabilize the picture if it rolls vertically.

#### 7 DC 12V IN jack (XLR, 4 pin)

Connect the Sony battery adaptor DC-L10 (not supplied).

#### 8 COMPONENT LEVEL selector

Select the component level from among two modes.

**N10/SMPTE:** for 100.0/100.0 signal

**BETA 0:** for 100.0/75.0 signal

#### 5 RGB/COMPONENT input connectors

**R/R-Y, G/Y, B/B-Y (BNC), AUDIO (phono):** To monitor a signal fed through these connectors, depress the LINE/RGB selector on the front panel (RGB). When the SYNC INT/EXT selector on the front panel is released (INT), the monitor operates on the sync signal from the G/Y channel.

#### To monitor the analog RGB signal

Connect to the analog RGB signal outputs of a video camera. Keep the A/B, RGB/Y R-Y B-Y selector on the front panel released (RGB).

#### To monitor the component signal

Connect to the R-Y/Y/B-Y component signal outputs of a Sony BetaCam video camera. Depress the A/B, RGB/Y R-Y B-Y selector on the front panel (Y R-Y B-Y).

#### 3 AC IN socket

Connect the supplied AC power cord to this socket and to a wall outlet.

#### 10 EJECT buttons

Press the EJECT button upwards to remove the battery pack.

#### 8 BATTERY compartments

Insert the NP-1B battery pack (not supplied).

## Power Sources

### House Current (for all models)

Connect the supplied AC power cord to the AC IN socket and to a wall outlet.

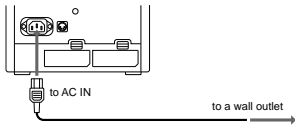

#### For the PVM-9045QM/9042QM

When the AC power cord is plugged into the AC IN socket, the battery pack (if installed) or the DC 12 V IN jack (if connected) is automatically disconnected.

To connect an AC power cord securely with AC plug holders.

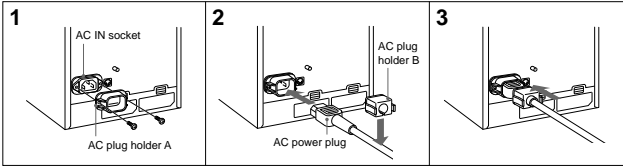

- 1 Remove the AC IN socket screws and then use them to attach the AC plug holder A (supplied) to the AC IN socket.
- 2 Plug the power cord to the AC IN socket. Then, attach the supplied AC plug holder B on top of the AC power cord.
- 3 Slide AC plug holder B over the cord until it locks.

**To remove the AC power cord**  
Pull out AC plug holder B by squeezing the left and right sides.

### Rechargeable Battery (PVM-9045QM/9042QM only)

The monitor can operate with one or two battery packs. For extended use, two battery packs are recommended.

**To remove the battery pack**, press the EJECT button upwards.

**For charging**, use the BC-1WDCE for the NP-1B.

**Note**  
Make sure you disconnect the cables connected to the connectors (AC IN, DC 12 V IN) at the rear of the monitor. Otherwise, the monitor cannot operate on the battery pack(s).

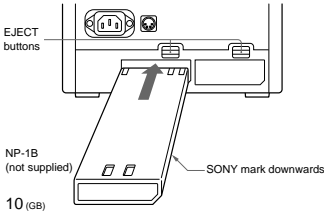

10 (GB)

## Specifications

### Video signal

Colour system	PVM-9045QM/9042QM: PAL, SECAM, NTSC, NTSC4.43 PVM-9040ME: PAL, SECAM
Resolution	PVM-9045QM: 450 TV lines PVM-9042QM/9040ME: 250 TV lines
Aperture correction	-4.0 dB to +6.0 dB (at 3.0 MHz)
Frequency response	6.0 MHz (-3.0 dB)
Synchronization	AFC time constant 1.0 msec.

### Picture performance

Normal scan	6% over scan of CRT effective screen area
Underscan	3% underscan of CRT effective screen area
H. linearity	Less than 5.0% (typical)
V. linearity	Less than 5.0% (typical)
Convergence	Central area: 0.43 mm (typical) Peripheral area: 0.53 mm (typical)
Raster size stability	H: 1.0%, V: 1.5%
High voltage regulation	3.0%
Colour temperature	D65

### Inputs and Outputs

Connector	Model	PVM-9045QM PVM-9042QM	PVM-9040ME
LINE A	Y/C IN	yes	yes
	Y/C OUT	yes	yes
	VIDEO IN	yes	yes
	VIDEO OUT	yes	yes
	AUDIO IN AUDIO OUT	yes yes	yes yes
LINE B	VIDEO IN	yes	no
	VIDEO OUT	yes	no
	AUDIO IN AUDIO OUT	yes yes	no no
RGB/ COMPONENT	R/R-Y IN	yes	no
	G/Y IN	yes	no
	B/B-Y IN	yes	no
	AUDIO IN	yes	no
EXT SYNC	IN	yes	no
	OUT	yes	no
REMOTE		yes	no

### Inputs

Y/C IN: 4-pin mini DIN connector  
See the pin assignment on page 12 (GB).  
VIDEO IN: BNC connector  
1 Vp-p  $\pm$  6 dB, sync negative  
AUDIO IN: phono jack, -5 dBu<sup>a)</sup>, less than 47 kohms  
R/R-Y, G/Y, B/B-Y: BNC connector  
R, G, B channels: 0.7 Vp-p,  $\pm$  6 dB Sync on green: 0.3 Vp-p, negative  
R-Y, Y, B-Y channels: 0.7 Vp-p,  $\pm$  6 dB (Standard colour bar signal of 100% chrominance)  
EXT SYNC IN: BNC connector  
Composite sync 4 Vp-p,  $\pm$  6 dB, negative

### Loop-through outputs

Y/C OUT: 4-pin mini DIN connector, 75 ohms terminated (75 ohms automatic termination)  
VIDEO OUT: BNC connector, 75 ohms terminated (75 ohms automatic termination)  
AUDIO OUT: phono jack  
EXT SYNC OUT: BNC connector, 75 ohms terminated  
Output level: 0.5W  
REMOTE: 8-pin mini DIN connector (75 ohms automatic termination)  
See the pin assignment on page 12 (GB).

### Speaker output

### Remote input

a) 0 dBu = 0.775 V<sub>r.m.s.</sub>

### General

Power consumption & requirements  
PVM-9045QM/9042QM:  
0.7 to 0.4A 43W at 100 to 240V AC operation  
3.7A 40W at 12 V DC operation  
PVM-9040ME:  
0.7 to 0.4A 39W at 100 to 240V AC operation

### Operating conditions

Temperature	0 to +35°C (32 to 95°F)
Humidity	0 to 90% (no condensation)
Pressure	700 to 1060 hPa

11 (GB)

## Specifications

### Transport and storage conditions

Temperature	-10 to +40°C (14 to 104°F)
Humidity	0 to 90%
Pressure	700 to 1060 hPa
Dimensions	Approx. 217 x 217 x 352.5 mm (w/h/d) (8 5/8 x 8 5/8 x 14 inches) not incl. projecting parts and controls
Mass	Approx. 8.2 kg (18 lb 1 oz) not incl. battery packs
Accessory supplied	AC power cord (1) Cable with an 8-pin connector (1) (PVM-9045QM/9042QM only) AC plug holders (1 set) Tally plate (1) (PVM-9045QM/ 9042QM only)

Design and specifications are subject to change  
without notice.

### Pin Assignment

#### Y/C IN connector (4-pin mini DIN)



Pin No.	Signal	Description
1	Y-input	1 Vp-p, sync negative, 75 ohms
2	CHROMA sub-carrier-input	300 mVp-p (PAL), burst Delay time between Y and C: within 0 ±100 nsec., 75 ohms
3	GND for Y-input	GND
4	GND for CHROMA-input	GND

#### REMOTE connector (8-pin mini DIN)

(PVM-9045QM/9042QM only)



Pin No.	Signal
1	16:9
2	H/V delay
3	GND
4	EXT SYNC
5	Tally
6	Underscan
7	A/B or RGB/Y R-Y B-Y
8	LINE/RGB

#### Notes

- For remote control, connect the pin of the desired function to pin 3 (GND).
- For remote control, set the front button to OFF (the switch is out).



**SONY**

3-865-341-11 (1)

***Trinitron®  
Color Video Monitor***

---

Operating Instructions

**US**



**PVM-9045PM**

© 1998 by Sony Corporation

English

**WARNING**

To prevent fire or shock hazard, do not expose the unit to rain or moisture.

Dangerously high voltages are present inside the unit. Do not open the cabinet. Refer servicing to qualified personnel only.

THIS APPARATUS MUST BE EARTHED



This symbol is intended to alert the user to the presence of uninsulated "dangerous voltage" within the product's enclosure that may be of sufficient magnitude to constitute a risk of electric shock to persons.



This symbol is intended to alert the user to the presence of important operating and maintenance (servicing) instructions in the literature accompanying the appliance.

**For the customers in the USA**

This equipment has been tested and found to comply with the limits for a Class A digital device, pursuant to Part 15 of the FCC Rules. These limits are designed to provide reasonable protection against harmful interference when the equipment is operated in a commercial environment. This equipment generates, uses, and can radiate radio frequency energy and, if not installed and used in accordance with the instruction manual, may cause harmful interference to radio communications. Operation of this equipment in a residential area is likely to cause harmful interference in which case the user will be required to correct the interference at his own expense.

You are cautioned that any changes or modifications not expressly approved in this manual could void your authority to operate this equipment.

2 (US)

In the event of a malfunction or when maintenance is necessary, consult an authorized Sony dealer.

Ensure that your equipment is connected correctly. If you are in any doubt consult a qualified electrician.

**CAUTION:**

Danger of explosion if battery is incorrectly replaced. Replace only with the same or equivalent type recommended by the manufacturer. Discard used batteries according to the manufacturer's instructions.

**Precautions****On safety**

- **PVM-9045PM:** Operate the unit on 120 V AC or 12 V DC. For the AC operation, use only the supplied AC power cord or the AC power adaptor recommended (not supplied). Do not use any other type. For the battery operation, use only the NP-1B battery pack and BP-L60A/L-90A with DC-L10 (not supplied). Do not use any other batteries.
- Should any liquid or solid object fall into the cabinet, unplug the unit and have it checked by qualified personnel before operating it further.
- Unplug the unit from the wall outlet if it is not to be used for several days.
- To disconnect the AC power cord, pull it out by the plug. Never pull the cord itself.

**On installation**

- Allow adequate air circulation to prevent internal heat build-up. Do not place the unit on surfaces (rugs, blankets, etc.) or near materials (curtains, draperies) that may block the ventilation holes.
- Do not install the unit near heat sources such as radiators or air ducts, or in a place subject to direct sunlight, excessive dust, mechanical vibration or shock.
- Keep the unit away from a loudspeaker or motor, as the picture may be affected.

**On cleaning**

Clean the unit with a slightly dampened soft cloth. Use a mild household detergent. Never use strong solvents such as thinner or benzene as they might damage the finish of the cabinet. As a safety precaution, unplug the unit before cleaning it.

**On repacking**

Retain the original carton and packing materials for safe transport of this unit in the future.

If you have any questions about this unit, contact your authorized Sony dealer.

**ATTENTION – When the product is installed in a rack:**

- Elevated operating ambient temperature**  
If installed in a closed or multi-unit rack assembly, the operating ambient temperature of the rack environment may be greater than room ambient. Therefore, consideration should be given to installing the equipment in an environment compatible with the manufacturer's maximum rated ambient temperature of 0 to +35°C (32 to 95°F) (Tmra).
- Reduced air flow**  
Installation of the equipment in a rack should be such that the amount of air flow required for safe operation of the equipment is not compromised.
- Mechanical loading**  
Mounting of the equipment in the rack should be such that a hazardous condition is not achieved due to uneven mechanical loading.
- Circuit overloading**  
Consideration should be given to the connection of the equipment to the supply circuit and the effect that overloading of circuits might have on overcurrent protection and supply wiring. Appropriate consideration of equipment nameplate ratings should be used when addressing this concern.
- Reliable earthing**  
Reliable earthing of rack-mounted equipment should be maintained. Particular attention should be given to supply connections other than direct connections to the branch circuit (e.g., use of power strips).

3 (US)

## Table of Contents

<b>Features</b> .....	<b>5</b>
<b>Location and function of parts and controls</b> .....	<b>6</b>
Front .....	6
Rear .....	8
<b>Power sources</b> .....	<b>10</b>
<b>Specifications</b> .....	<b>11</b>

## Features

**PAL-M and NTSC color systems available**  
The monitor can display PAL-M, NTSC signals. The appropriate color system is selected automatically.

**HR (High Resolution) Trinitron<sup>®</sup> picture tube**  
The HR Trinitron picture tube (0.25 mm aperture grill pitch) provides a high resolution picture. Horizontal resolution is more than 450 TV lines at the center of the picture.

**Beam current feedback circuit**  
The built-in beam current feedback circuit assures stable white balance.

**Comb filter**  
When NTSC video signals are received, a comb filter activates to increase the resolution, resulting fine picture detail without color spill or color noise.

**Multiple input signals**  
In addition to the composite video signals and the Y/C signals, analog RGB signals and component signals can be input.

**External sync input**  
When the EXT SYNC button is pressed, the monitor can be operated on the sync signal fed through an external sync connector.

**Blue only picture**  
Black and white apparent picture consisting from only the blue signal will be displayed. This facilitates the "chroma" and "phase" adjustment, and the observation of the video noise.

**16:9 selector**  
The monitor can display the 16:9 signal with the correct ratio of width and height, compressing the picture vertically.

**Under scan mode**  
The monitor can display signals that are scanned outside the normal screen so you can monitor the whole image.

**Audio circuit and built-in speaker**  
A speaker (0.5 W, monaural) is built into the monitor for sound monitoring.

**Automatic/Manual DEGAUSS**  
The screen is automatically demagnetized when the monitor is turned on. Manual degauss is also available by pressing the DEGAUSS button.

**Automatic termination**  
(only connectors marked  $\sphericalangle$ )  
The Y/C, VIDEO IN and EXT SYNC IN connectors are terminated at 75 ohms inside, when no cable is connected to the loop-through output connectors. When a cable is connected to an output connector, the 75-ohm termination is automatically released.

**EIA standard 19-inch rack mounting**  
By using an MB-507 mounting bracket (not supplied), the monitor can be mounted in an EIA standard 19-inch rack. For details on mounting, see the instruction manual of the MB-507.

**Varied power sources**  
In addition to AC power, you can use battery pack or external DC 12 V power. The monitor can operate with one or two Sony NP-1B\* battery packs. If you use the DC-L10\* battery adaptor, the monitor can operate with a Sony BP-L60A/L90A\* lithium ion battery pack.

\* The NP-1B battery pack, DC-L10 battery adaptor and BP-L60A/L90A battery pack are not supplied.

## Location and Function of Parts and Controls

### Front

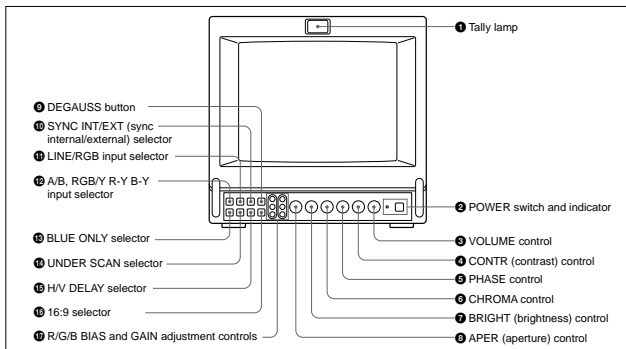

#### 1 Tally lamp

This indicator lights up. The tally control connection is needed.  
For the pin assignment, see "Specifications" on page 12 (US).

#### 2 POWER switch and indicator

Depress to turn the monitor on. The indicator will light up in green.  
The POWER indicator also functions as the battery indicator. When the internal battery becomes weak or the power supplied through the DC 12 V IN jack decreases, the indicator flashes.

#### 3 VOLUME control

Turn this control clockwise or counterclockwise to obtain the desired volume.

#### 4 CONTR (contrast) control

Turn clockwise to make the contrast stronger and counterclockwise to make it weaker.

#### 5 PHASE control

This control is effective only for the NTSC and NTSC4.43 color systems. Turn clockwise to make the skin tones greenish and counterclockwise to make them purplish.

6 (US)

#### 6 CHROMA control

Turn clockwise to make the colour intensity stronger and counterclockwise to make it weaker.

#### 7 BRIGHT (brightness) control

Turn clockwise for more brightness and counterclockwise for less.

#### 8 APER (aperture) control

Turn clockwise for more sharpness and counterclockwise for less.

#### Notes

- The PHASE, CHROMA and APER control settings have no effect on an analog RGB signal.
- The PHASE control has no effect on component signals.
- The PHASE control setting is effective only for the NTSC system.

#### 9 DEGAUSS button

Press this button momentarily. The screen will be demagnetized.

#### Note

If you press the DEGAUSS button again too soon, the color shades may be uneven.

#### 10 SYNC INT/EXT (sync internal/external) selector

Keep this button released (INT) to operate the monitor on the sync signal from the displayed composite video signal.  
Depress this button (EXT) to operate the monitor on an external sync signal fed through the EXT SYNC connector on the rear panel.

#### 11 LINE/RGB input selector

Select the programme to be monitored. Keep this button released (LINE) for a signal fed through the LINE A or LINE B connectors. Depress this button (RGB) for a signal fed through the RGB connectors.

#### 12 A/B, RGB/Y R-Y B-Y input selector

**When the LINE/RGB input selector is set to LINE,** keep this button released (A) for a signal fed through the LINE A connectors. Press this button (B) to monitor the signals from the LINE B connector.

**When the LINE/RGB input selector is set to RGB,** select the RGB signal or the component signal which is fed through the RGB input connectors. Keep this button released (RGB) for the RGB signal. Press this button (Y R-Y B-Y) to monitor the component signals.

#### 13 BLUE ONLY selector

Depress this button to turn off the red and green signals. A blue signal is displayed as an apparent monochrome picture on the screen. This facilitates "chroma" and "phase" control adjustments and the observation of video noise.

#### Note

The PHASE control adjustments is effective only for the NTSC system.

#### 14 UNDER SCAN selector

Depress this button for underscanning. The display size is reduced by approximately 3% so that four corners of the picture are visible.

#### 15 H/V DELAY selector

Depress this button to observe the horizontal and vertical sync signals at the same time. The horizontal sync signal is displayed in the left quarter of the screen; the vertical sync signal is displayed near the center of the screen.

#### 16 16:9 selector

Press this selector to monitor the signals of 16:9 picture.  
Pressing the UNDER SCAN selector 14 in 16:9 mode displays the whole 16:9 picture up to the four corners.

#### 17 R/G/B BIAS and GAIN adjustment controls

Used for white balance fine adjustment.  
BIAS and GAIN controls are provided for the R (red), G (green) and B (blue) screens.  
**BIAS:** Adjust the white balance and brightness of the screen at the lowlight.  
**GAIN:** Adjust the white balance and brightness of the screen at the highlight.

7 (US)

## Location and Function of Parts and Controls

### Rear

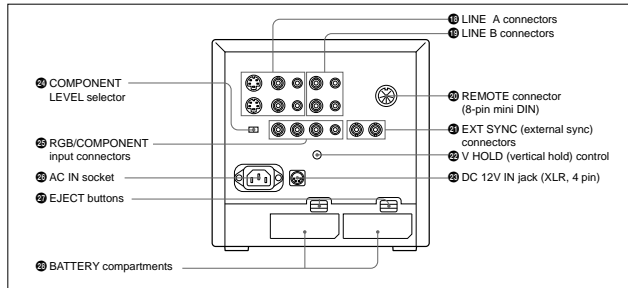

#### 1 LINE A connectors

**Y/C IN (4-pin mini DIN):** Connect to the Y/C separate output of a video camera, VCR or other video equipment.

**Y/C OUT (4-pin mini DIN):** Loop-through output of the Y/C IN connector. Connect to the Y/C separate input of a VCR or another monitor.

**VIDEO IN (BNC):** Connect to the video output of a video camera, VCR or other video equipment.

**VIDEO OUT (BNC):** Loop-through output of the VIDEO IN connector. Connect to the video input of a VCR or another monitor.

**AUDIO IN (phono jack):** Connect to the audio output of a VCR or a microphone (through a suitable microphone amplifier).

**AUDIO OUT (phono jack):** Loop-through output of the AUDIO IN connector. Connect to the audio input of a VCR or another monitor.

#### Note

The Y/C IN connector has a priority over the VIDEO IN connector. When a plug is connected to the Y/C IN connector, the VIDEO IN connector is automatically disconnected.

To monitor the signal fed through these connectors, keep the LINE/RGB selector and the A/B, RGB/Y R-Y B-Y selector on the front panel released (LINE and A).

#### 11 LINE B connectors

To monitor the signal fed through these connectors, keep the LINE/RGB selector released (LINE) and depress the A/B, RGB/Y R-Y B-Y selector on the front panel (B).

**VIDEO IN (BNC):** Connect to the video output of a video camera, VCR or other video equipment.

**VIDEO OUT (BNC):** Loop-through output of the VIDEO IN connector. Connect to the video input of a VCR or another monitor.

**AUDIO IN (phono jack):** Connect to the audio output of a VCR or a microphone (through a suitable microphone amplifier).

**AUDIO OUT (phono jack):** Loop-through output of the AUDIO IN connector. Connect to the audio input of a VCR or another monitor.

#### 8 REMOTE connector (8-pin mini DIN)

Connect to the tally output of a control console, special-effect generator, etc. The tally lamp on the front panel will be turned on and off by the connected equipment. This connector can be used for connecting a remote controller.

For the pin assignment of this connector, see "Specifications" on page 12 (US).

#### 9 EXT SYNC (external sync) connectors

**IN (BNC):** When this monitor operates on an external sync signal, connect the reference signal from a sync generator to this connector. In this case, depress the SYNC INT/EXT selector on the front panel (EXT).

**OUT (BNC):** Loop-through output of the EXT SYNC IN connector. Connect to the external sync input of video equipment to be synchronized with this monitor.

#### 10 V HOLD (vertical hold) control

Turn to stabilize the picture if it rolls vertically.

#### 11 DC 12V IN jack (XLR, 4 pin)

Connect the Sony battery adaptor DC-L10 (not supplied).

#### 3 COMPONENT LEVEL selector

Select the component level from among two modes.

**N10/SMPT E:** for 100/0/100/0 signal  
**BETA 0:** for 100/0/75/0 signal

#### 4 RGB/COMPONENT input connectors

**R/R-Y, G/Y, B/B-Y (BNC), AUDIO (phono):** To monitor a signal fed through these connectors, depress the LINE/RGB selector on the front panel (RGB). When the SYNC INT/EXT selector on the front panel is released (INT), the monitor operates on the sync signal from the G-Y channel.

#### To monitor the analog RGB signal

Connect to the analog RGB signal outputs of a video camera. Keep the A/B, RGB/Y R-Y B-Y selector on the front panel released (RGB).

#### To monitor the component signal

Connect to the R-Y/Y/B-Y component signal outputs of a Sony BetaCam video camera. Depress the A/B, RGB/Y R-Y B-Y selector on the front panel (Y R-Y B-Y).

#### 5 AC IN socket

Connect the supplied AC power cord to this socket and to a wall outlet.

#### 6 EJECT buttons

Press the EJECT button upwards to remove the battery pack.

#### 7 BATTERY compartments

Insert the NP-1B battery pack (not supplied).

## Power Sources

### House Current (for all models)

Connect the supplied AC power cord to the AC IN socket and to a wall outlet.

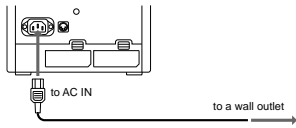

When the AC power cord is plugged into the AC IN socket, the battery pack (if installed) or the AC power adaptor (if connected) is automatically disconnected.

To connect an AC power cord securely with AC plug holders.

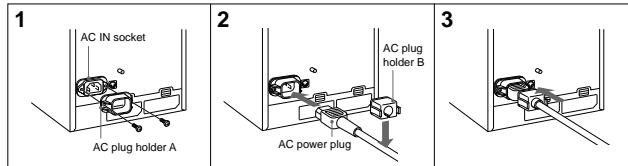

**1** Remove the AC IN socket screws and then use them to attach the AC plug holder A (supplied) to the AC IN socket.

**2** Plug the power cord to the AC IN socket. Then, attach the supplied AC plug holder B on top of the AC power cord.

**3** Slide AC plug holder B over the cord until it locks.

**To remove the AC power cord**  
Pull out AC plug holder B by squeezing the left and right sides.

### Rechargeable Battery

The monitor can operate with one or two battery packs. For extended use, two battery packs are recommended.

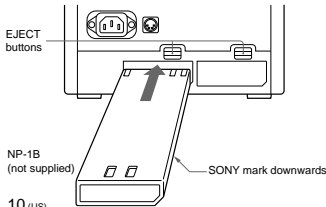

10 (US)

**To remove the battery pack**, press the EJECT button upwards.

**For charging**, use the BC-1WD for the NP-1B.

**Note**  
Make sure you disconnect the cables connected to the connectors (AC IN, DC 12 V IN) at the rear of the monitor. Otherwise, the monitor cannot operate on the battery pack(s).

## Specifications

### Video signal

Color system	PAL-M, NTSC
Resolution	450 TV lines
Aperture correction	-4.0 dB to +6.0 dB (at 3.0 MHz)
Frequency response	6.0 MHz (-3 dB) at all inputs
Synchronization	AFC time constant 1.0 msec.

### Picture performance

Normal scan	6% over scan of CRT effective screen area
Underscan	3% underscan of CRT effective screen area
H. linearity	Less than 5.0% (typical)
V. linearity	Less than 5.0% (typical)
Convergence	Central area: 0.43 mm (typical) Peripheral area: 0.53 mm (typical)
Raster size stability	H: 1.0%, V: 1.5%
High voltage regulation	3.0%
Color temperature	D65

### Inputs and Outputs

Inputs	Y/C IN: 4-pin mini DIN connector See the pin assignment on page 12 (US). VIDEO IN: BNC connector 1 Vp-p $\pm$ 6 dB, sync negative AUDIO IN: phono jack, -5 dBu <sup>a</sup> , less than 47 kohms R/R-Y, G/Y, B/B-Y: BNC connector R, G, B channels: 0.7 Vp-p, $\pm$ 6 dB Sync on green: 0.3 Vp-p, negative. R-Y, Y, B-Y channels: 0.7 Vp-p, $\pm$ 6 dB (Standard colour bar signal of 75% chrominance) EXT SYNC IN: BNC connector Composite sync 4 Vp-p, $\pm$ 6 dB, negative
--------	--

### Loop-through outputs

Y/C OUT:	4-pin mini DIN connector, 75 ohms terminated (75 ohms automatic termination)
VIDEO OUT:	BNC connector, 75 ohms terminated (75 ohms automatic termination)
AUDIO OUT:	phono jack
EXT SYNC OUT:	BNC connector, 75 ohms terminated
Speaker output	Output level 0.5 W
Remote input	REMOTE: 8-pin mini DIN connector (75 ohms automatic termination) See the pin assignment on page 12 (US).

*a) 0 dBu = 0.775 V<sub>r.m.s.</sub>*

### General

Power consumption & requirements	0.6 A 45 W MAX at 120 V AC operation 3.7 A 38 W at 12 V DC operation
----------------------------------	---

### Operating conditions

Temperature	0 to +35°C (32 to 95°F)
Humidity	0 to 90% (no condensation)
Pressure	700 to 1060 hPa
Transport and storage conditions	
Temperature	-10 to +40°C (14 to 104°F)
Humidity	0 to 90%
Pressure	700 to 1060 hPa
Dimensions	Approx. 217 x 217 x 352.5 mm (w/h/d) (8 7/8 x 8 7/8 x 14 inches) not incl. projecting parts and controls
Mass	Approx. 8.2 kg (18 lb 1 oz) not incl. battery packs
Accessory supplied	AC power cord (1) Cable with an 8-pin connector (1) AC plug holders (1 set) Tally plate (1)

Design and specifications are subject to change without notice.

11 (US)

## Specifications

### Pin Assignment

Y/C IN connector (4-pin mini DIN)



Pin No.	Signal	Description
1	Y-input	1 Vp-p, sync negative, 75 ohms
2	CHROMA sub-carrier-input	300 mVp-p (PAL-M), 286 mVp-p (NTSC), burst Delay time between Y and C, within 0 ±100 nsec., 75 ohms
3	GND for Y-input	GND
4	GND for CHROMA-input	GND

REMOTE connector (8-pin mini DIN)  
(PVM-8045Q/8042Q only)



Pin No.	Signal
1	16:9
2	H/V delay
3	GND
4	EXT SYNC
5	Tally
6	Underscan
7	A/B or RGB/Y R-Y B-Y
8	LINE/RGB

#### Notes

- For remote control, connect the pin of the desired function to pin 3 (GND).
- For remote control, set the front button to OFF (the switch is out).

12 (US)





## SECTION 2

### SERVICE INFORMATION

#### 2-1. CIRCUIT BOARDS LOCATION

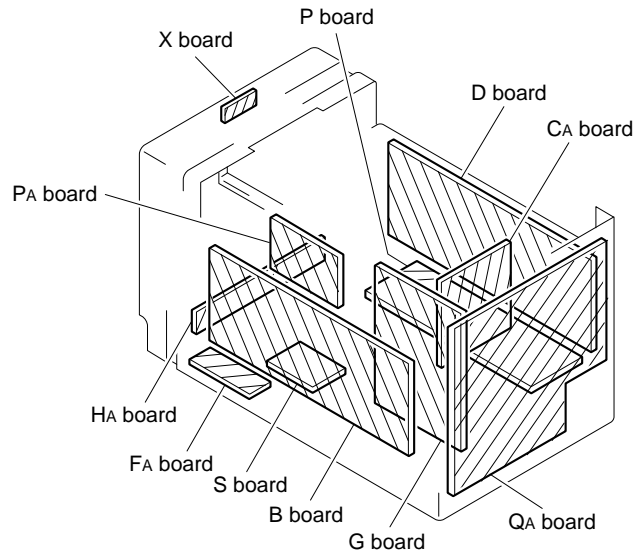

## 2-2. DISASSEMBLY

### 2-2-1. Cabinet Removal

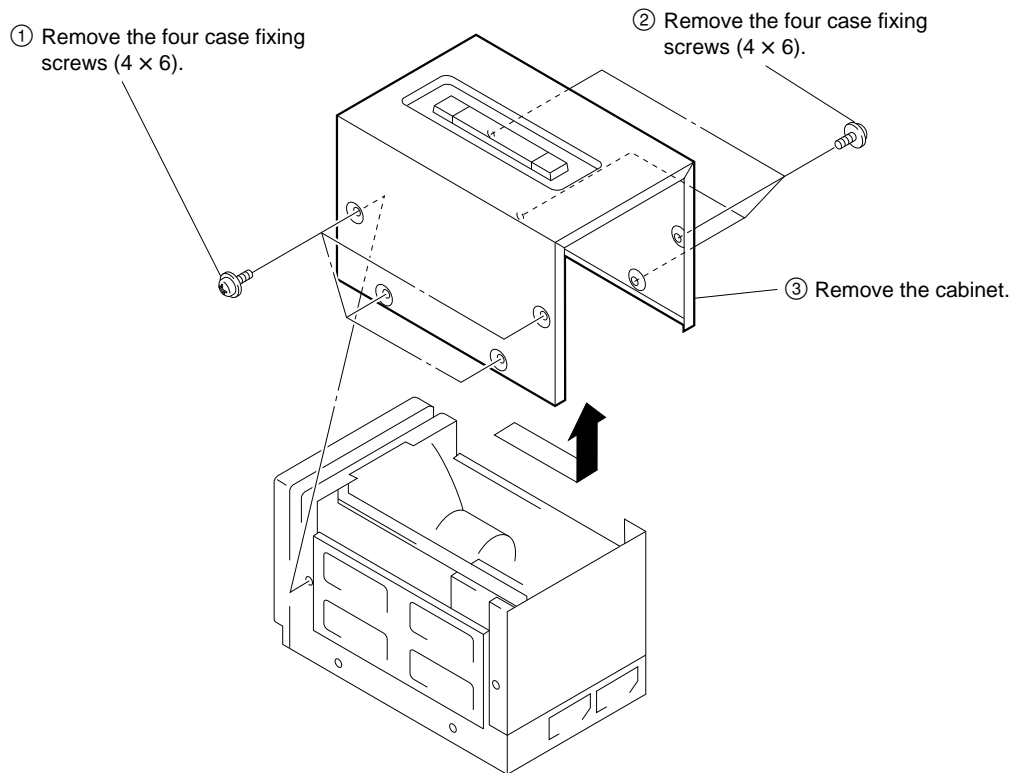

### 2-2-2. B Board Removal

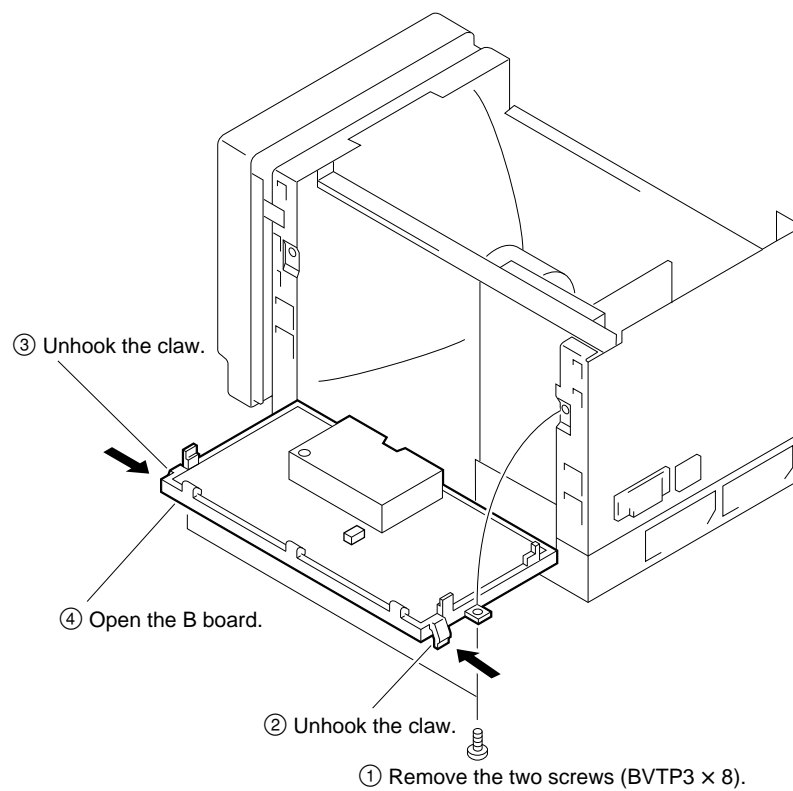

### 2-2-3. Switching Regulator Removal

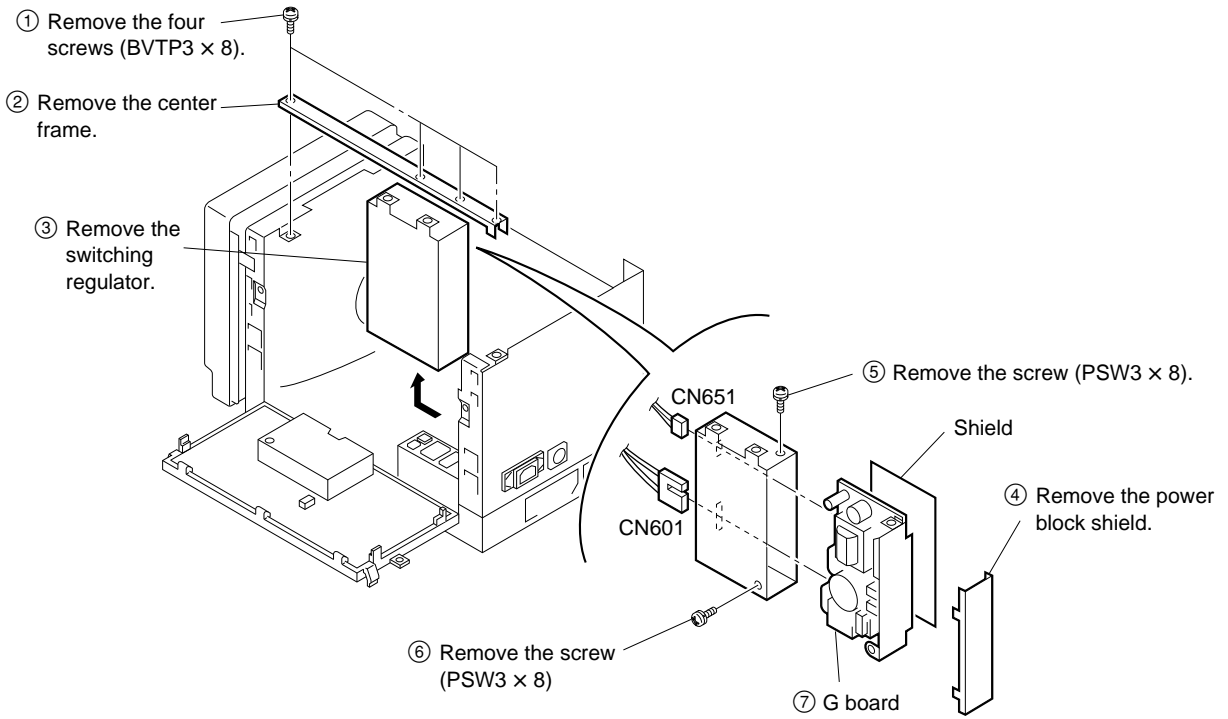

### 2-2-4. D Board Removal

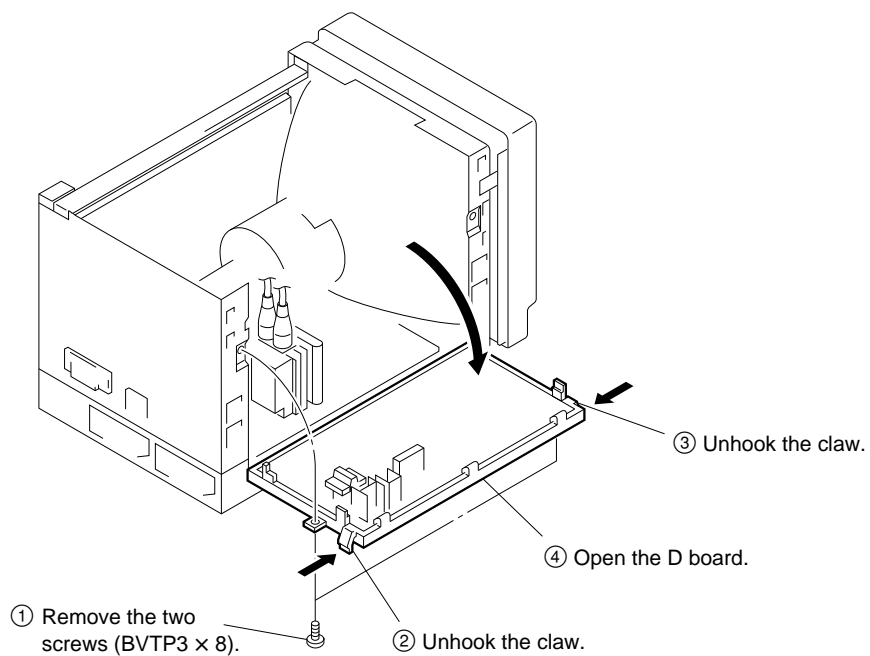

## 2-2-5. P Board Removal

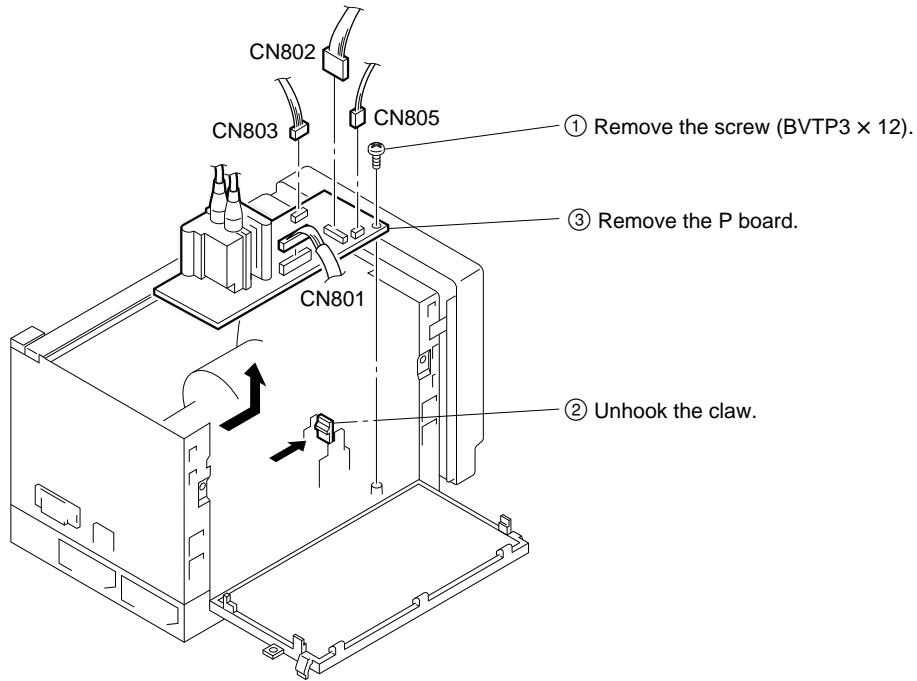

## 2-2-6. Rear Assembly Removal

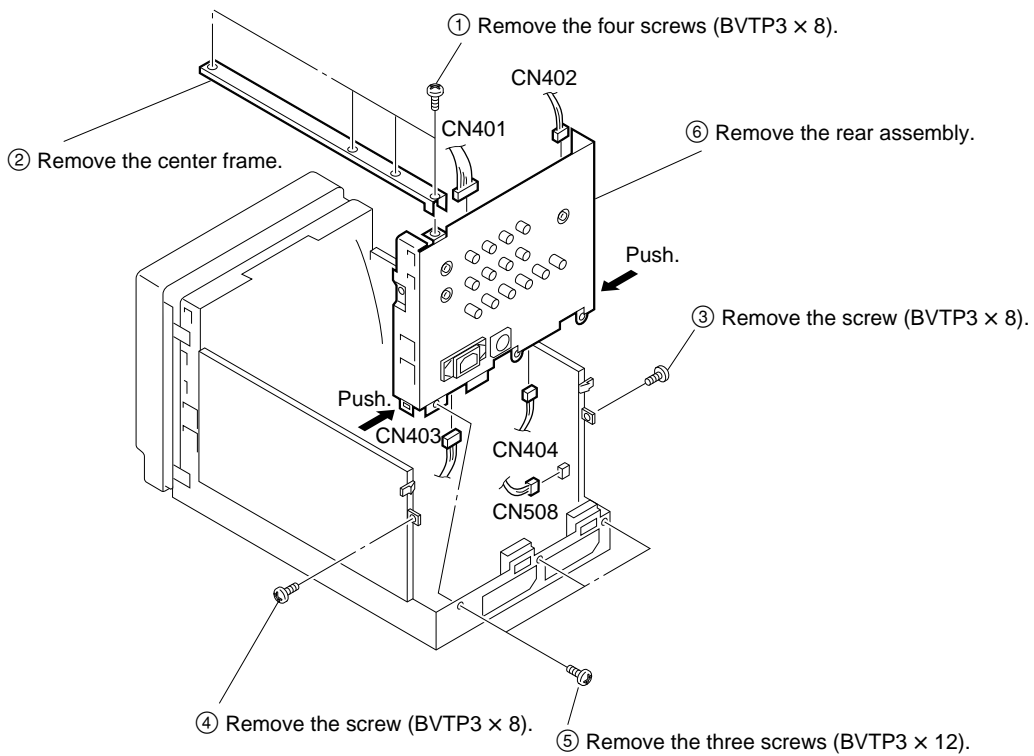

## 2-2-7. HA Board Removal

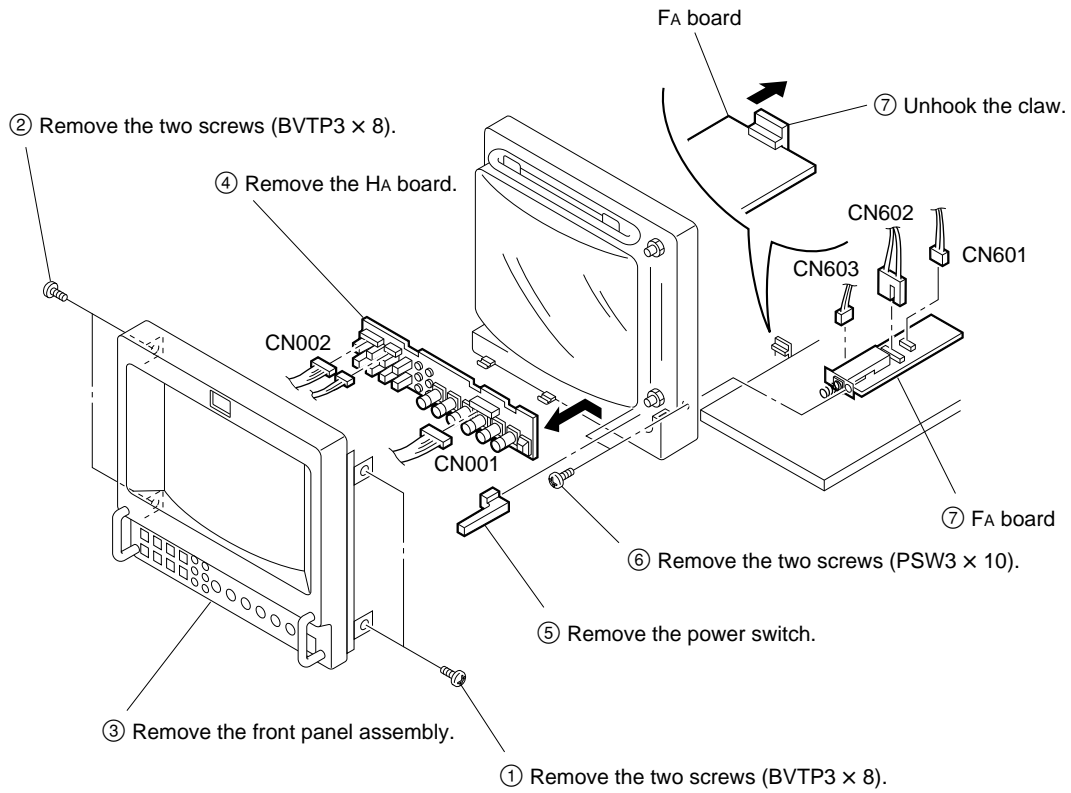

## 2-2-8. CRT Removal

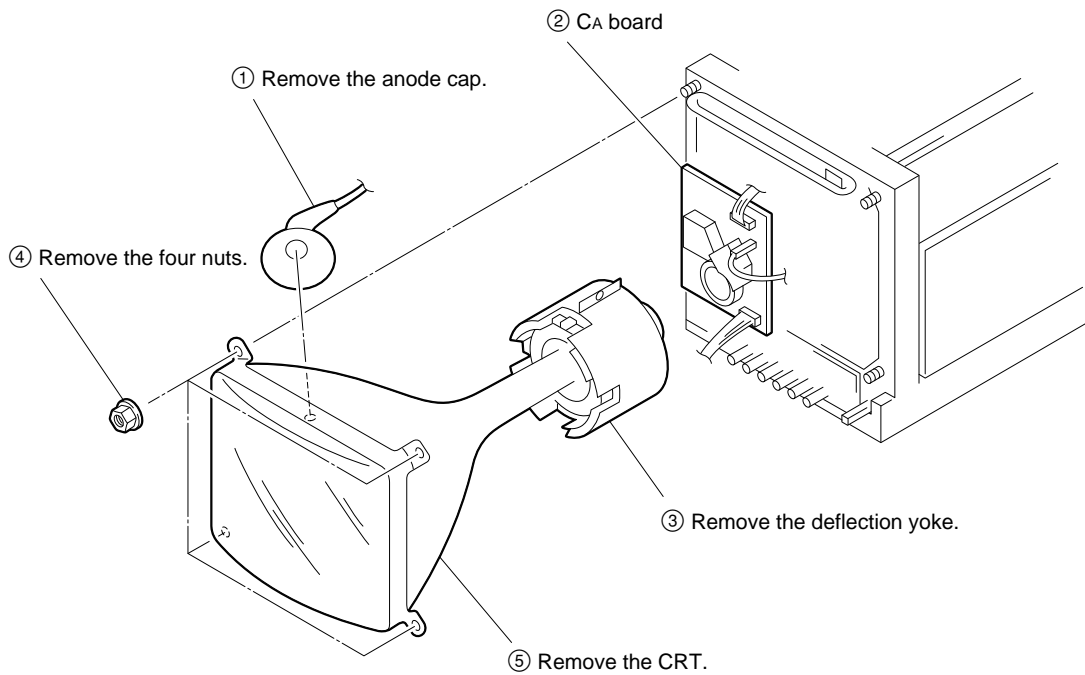

## 2-2-9. Removal of Anode-cap

**Note:** Short circuit the anode of the picture tube and the anode cap to the metal chassis, picture tube shield or carbon painted on the picture tube, after removing the anode.

### 1. Removing Procedures

- (1) Turn up one side of the rubber cap in the direction indicated by the arrow (a).

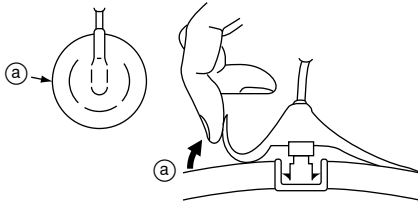

- (2) Using a thumb pull up the rubber cap firmly in the direction indicated by the arrow (b).

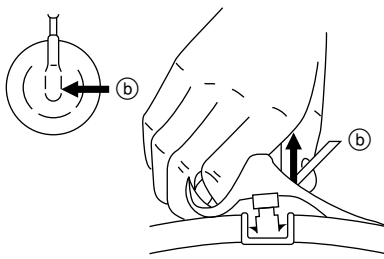

- (3) When one side of the rubber cap is separated from the anode button, the anode-cap can be removed by turning up the rubber cap and pulling up it in the direction of the arrow (c).

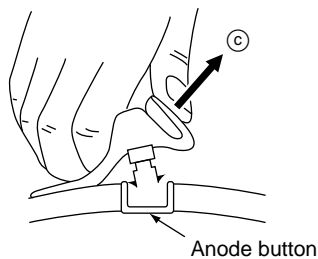

### 2. Handling Precautions

- (1) Don't hurt the surface of anode-caps with sharp shaped material!
- (2) Don't press the rubber hardly not to hurt inside of anode-caps!  
A material fitting called as shatter-hook terminal is built in the rubber.
- (3) Don't turn the foot of rubber over hardly!  
The shatter-hook terminal will stick out or hurt the rubber.

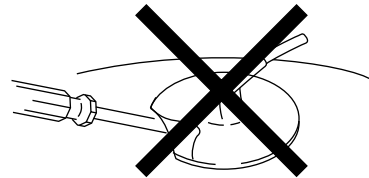
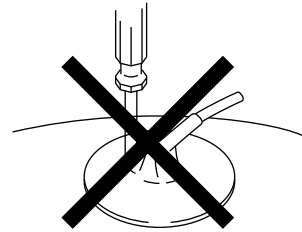

## 2-2-10. Equipment Required

- Oscilloscope Tektronix 2465 or equivalent (band width: 350 MHz or more)
- NTSC, PAL, PAL-M, SECAM component signal generator Tektronix TG2000 + AVG1 (optional module) + AWVG1 (optional module) or equivalent
- Monoscope signal generator Shibasoku TP22AX or equivalent
- Frequency counter Advantest TR5821AK or equivalent
- Digital voltmeter Advantest TR6845 or equivalent
- Variable step-up transformer (or NF power supply)
- High-tension meter
- Regulated DC power supply
- Ammeter
- Luminance meter





# SECTION 3

## SET-UP ADJUSTMENTS

### 3-1. PREPARATIONS

The following adjustments should be made when a complete realignment is required or a new picture tube is installed. These adjustments should be performed with rated power supply voltage unless otherwise noted.

The controls and selectors below should be set as follows unless otherwise noted.

#### Front Panel Controls

VOLUME control ..... 50 %  
CONTR control ..... 80 %  
PHASE control ..... 50 % (center click)  
CHROMA control ..... 50 % (center click)  
BRIGHT control ..... 50 % (center click)  
APER control ..... 50 % (center click)

#### Front Panel Selectors

SYNC INT/EXT selector ..... Pull (INT)  
LINE/RGB selector ..... Pull (LINE)  
A/B, RGB/Y R-Y B-Y selector ..... Pull (RGB)  
BLUE ONLY selector ..... Pull (OFF)  
UNDER SCAN selector ..... Pull (OFF)  
H/V DELAY selector ..... Pull (OFF)  
16 : 9 selector ..... Pull (4 : 3)

#### Rear Panel Control

V HOLD control ..... Stable position

Perform the adjustment in order as follows:

- 3-2. Landing Adjustment
- 3-3. Convergence Adjustment
- 3-4. Focus Adjustment
- 3-5. White Balance Adjustment

## 3-2. LANDING ADJUSTMENT

### 3-2-1. Preparations

1. To reduce geomagnetism effects, face the CRT screen to the east or west.
2. Turn on the power switch, and erase the magnetic force using a degausser.

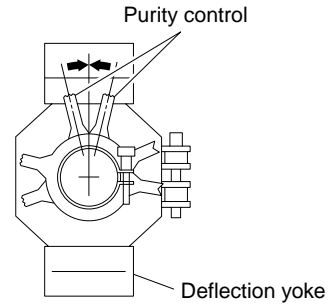

Fig. 3-1

### 3-2-2. Landing Adjustment

1. Receive the white signal, and set the CONTR and BRIGHT controls as follows:  
 CONTR: MAXIMUM  
 BRIGHT: set easy to observe
2. Adjust the white balance, screen (G2) voltage, and convergence roughly.
3. Loosen the deflection yoke mounting screw, and set the purity control to the center as shown in Fig. 3-1.
4. Set the test signal generator to green.
5. Move the deflection yoke backward, and adjust the purity control so that the green is in the center and blue and red are at the sides, evenly. (See Fig. 3-2.)
6. Move the deflection yoke forward, and adjust so that the entire screen becomes green.  
 (Repeat steps 4 to 7 as to red and blue.)
7. When the landing at the corners is not right, correct by using the magnet. (See Fig. 3-3.)  
**Note: When correction magnet is used, be sure to degauss the unit.**
8. When the position of the deflection yoke is determined, tighten it with a deflection yoke mounting screw.

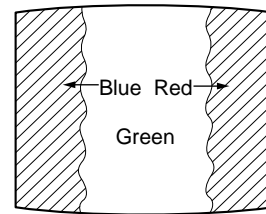

Fig. 3-2

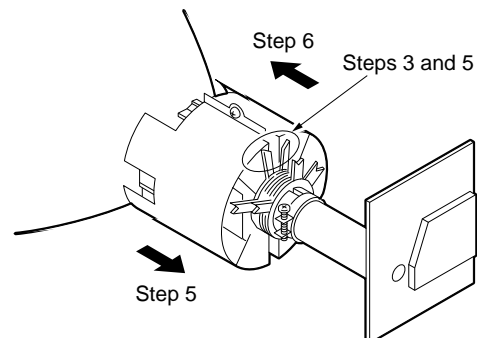
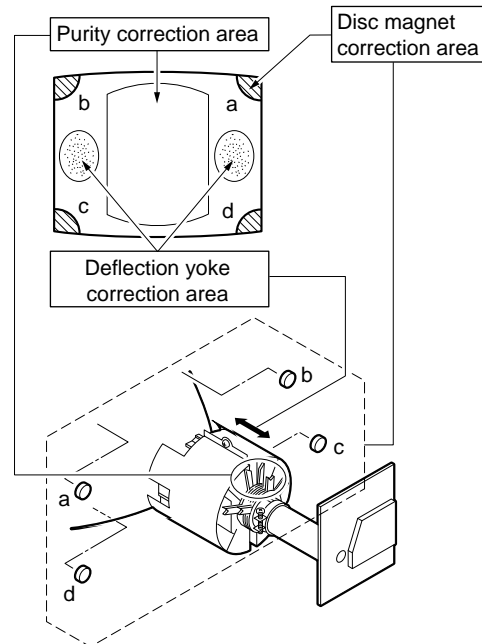

Fig. 3-3

### 3-3. CONVERGENCE ADJUSTMENT

#### 3-3-1. Horizontal and Vertical Convergence Adjustment on the Center of Screen

1. Before starting the fine adjustment, perform V.SIZE, V.CENT, H.SIZE, H.CENT and screen distortion adjustments roughly.
2. Receive a dot signal, and set the BRIGHT control to minimum and CONTR control to normal.
3. Adjust RV701 (H.STAT) on the CA board to coincide the Red, Green, and Blue dots on the center of screen (horizontal movement).
4. Adjust V.STAT magnet to coincide the Red, Green, and Blue dots on the center of screen (vertical movement).

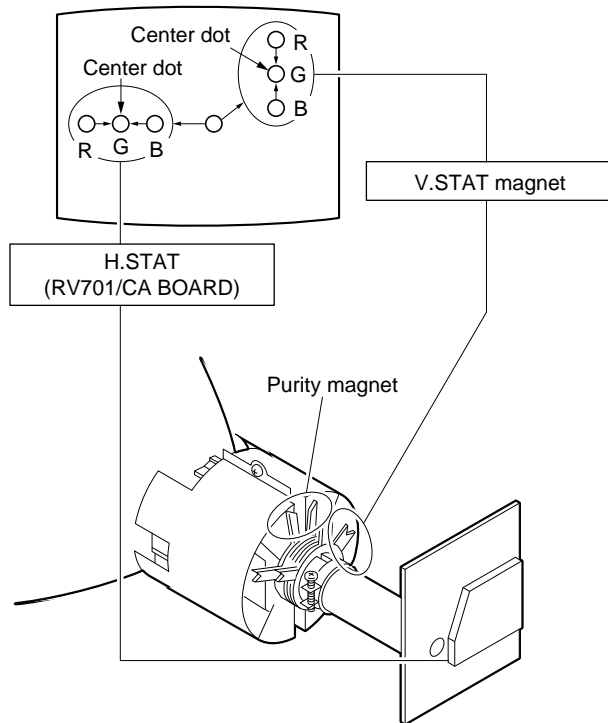

Fig. 3-4

**Note:** If Red, Green, and Blue dots do not coincide on the center of screen with RV701 (H.STAT) on the CA board, perform adjustment using V.STAT magnet at the same time while tracking. Tilt the V.STAT magnet and adjust static convergence to open or close the V.STAT magnet.

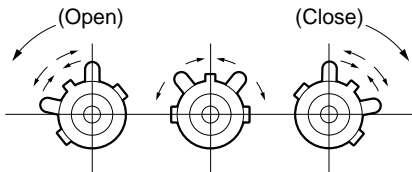

Fig. 3-5

5. The movement of Red, Green, and Blue dots by means of tilting, opening, and closing of the vertical static convergence magnet are as follows:

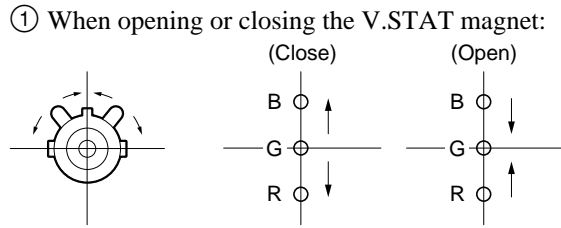

Fig. 3-6

- ② When tilting the V.STAT magnet counterclockwise:

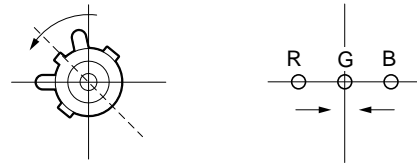

Fig. 3-7

- ③ When tilting the V.STAT magnet clockwise:

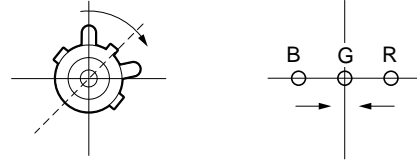

Fig. 3-8

- ④ When tilting the V.STAT magnet then open or close it:

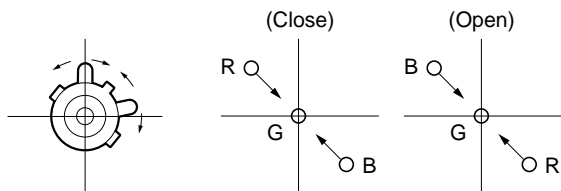

Fig. 3-9

**Note:** If Red and Green dots do not coincide with Blue dot, adjust with BMC (6-pole) magnet.

6. HMC/VMC correction with BMC (6-pole) magnet
  - ① HMC (Horizontal Misconvergence) correction and motion of the electron beam with BMC (6-pole) magnet:

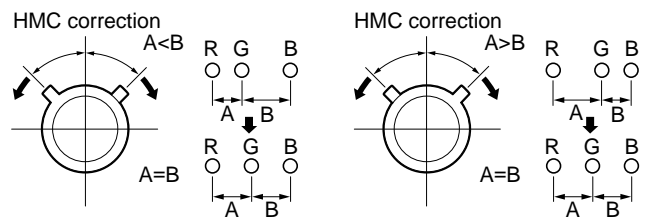

Fig. 3-10

② VMC (Vertical Misconvergence) correction and motion of the electron beam with BMC (6-pole) magnet:

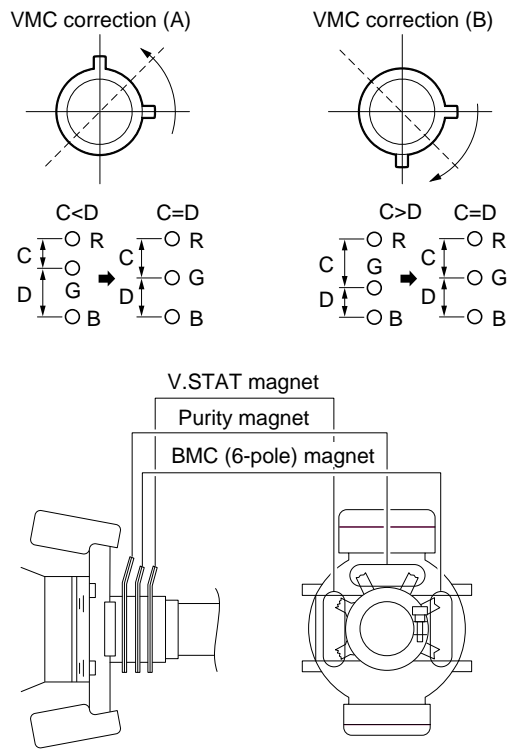

Fig. 3-11

### 3-3-2. Horizontal and Vertical Dynamic Convergence Adjustment in the Vicinity of Screen

1. When there is misconvergence at the sides of the screen, adjust the inclination of deflection yoke in accordance with the following steps.
2. Insert the three DY spacers between the deflection yoke and picture tube's funnel as shown in Fig. 3-12.
3. Adjust the convergence around the four corners with a permalloy.

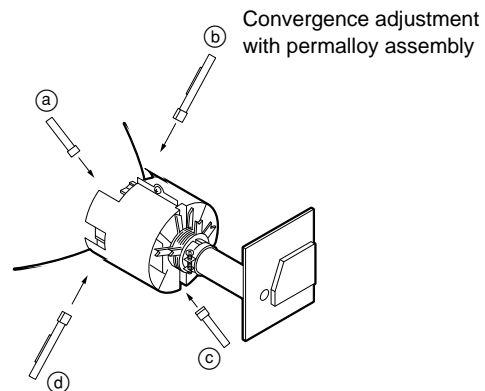
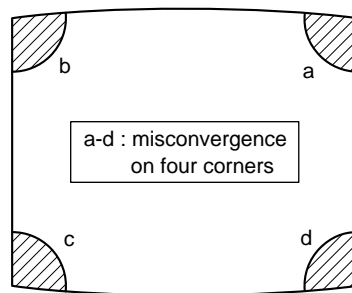

Fig. 3-13

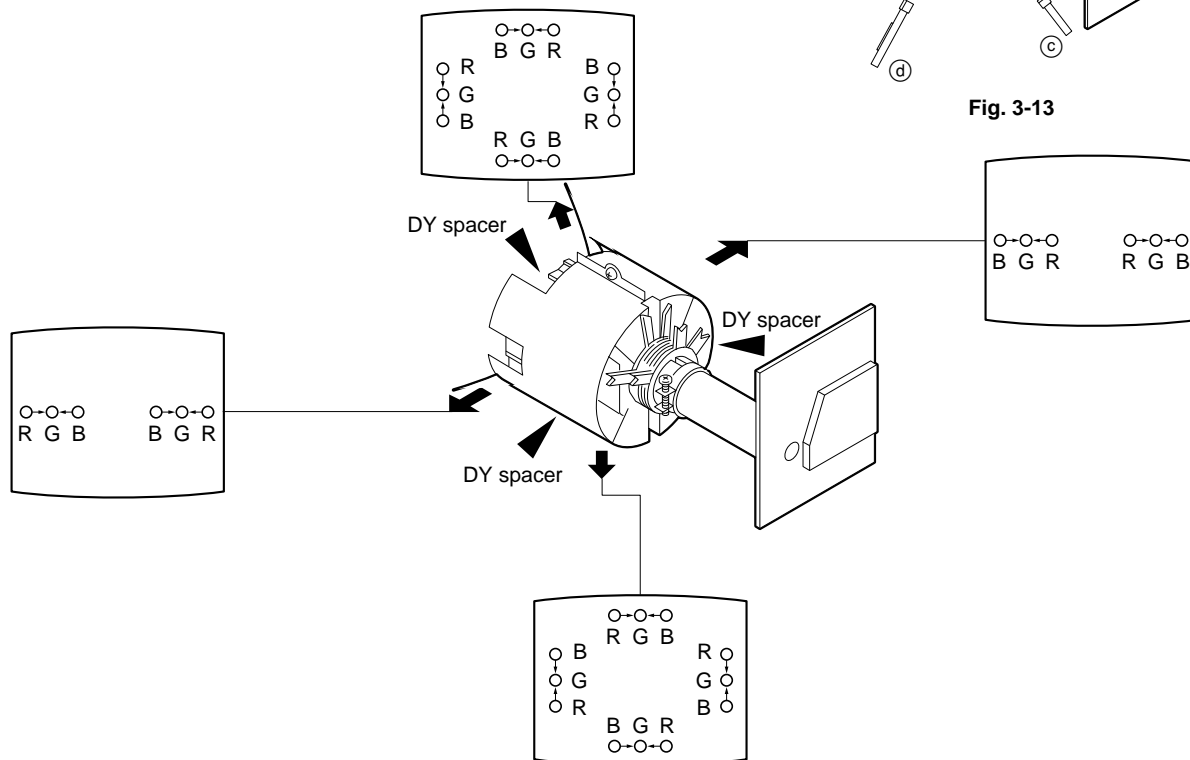

Fig. 3-12

### 3-4. FOCUS ADJUSTMENT

1. Receive the monoscope signal.
2. Set the CONTR control to normal.
3. Adjust the FOCUS control of the FBT so that the focus at the center of CRT screen and around the CRT screen become optimum.

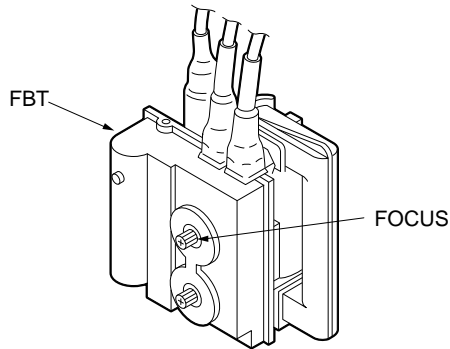

Fig. 3-14

### 3-5. WHITE BALANCE ADJUSTMENT

#### 3-5-1. Screen Voltage Adjustment

1. Receive the dot signal.
2. Connect a digital voltmeter to pin 5 (KG) of CRT socket. Adjust RV119 (G C/O) on the B board so that the voltage is 103 Vdc.
3. Connect a digital voltmeter to pin 9 (KB) of CRT socket. Adjust RV121 (B C/O) on the B board so that the voltage is 103 Vdc.
4. Adjust the SCREEN control of the FBT to the position where just before the flyback line disappears from the CRT screen.

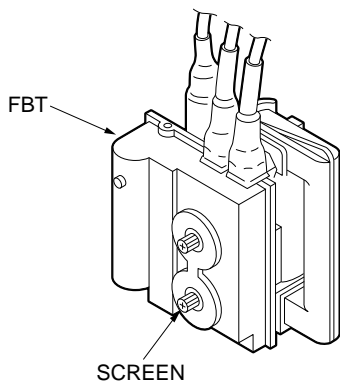

Fig. 3-15

#### 3-5-2. White Balance Adjustment

1. Receive the color bars signal. (Set the BURST switch of the test signal generator to OFF.)
2. Set the following controls on the front panel as follows:  
 BRIGHT ⇒ Center click  
 CONTR ⇒ Minimum  
 BIAS (Front panel) ⇒ 50 %  
 GAIN (Front panel) ⇒ 50 %
3. Adjust RV118 (SUB BRT) on the B board so that the blue stripe portion on the color bars signal is bright dimly.

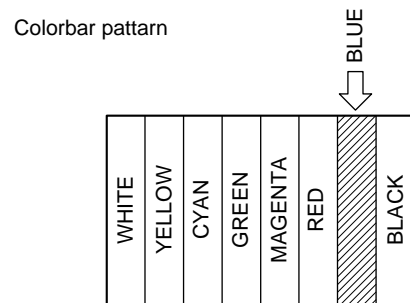

Fig. 3-16

4. Receive the white signal. (Set the BURST switch of the test signal generator to OFF.)
5. Set the CONTR control to 90 degrees clockwise from the center position.
6. Using the luminance meter, adjust the luminance level of the CRT screen so that it is 3 Nit. (Screen is bright dimly.)
7. Adjust the white balance of the cut-off with RV119 (G C/O) and RV121 (B C/O) on the B board.
8. Set the luminance level of white signal to 100 IRE with test signal generator.
9. Adjust the white balance of the high-light with RV120 (G GAIN) and RV122 (B GAIN) on the B board.
10. Press the BLUE ONLY switch on the front panel.
11. Adjust the white balance of the high-light with RV124 (R GAIN/BL) and RV125 (G GAIN/BL) on the B board.
12. Using the luminance meter, adjust the luminance level on the CRT screen with test signal generator so that it is 8 Nit. Then confirm that the white balance is adjusted correctly.



# SECTION 4

## SAFETY RELATED ADJUSTMENTS

**Note:** The “4-1. B+ Voltage Check” and “4-2. Protection Circuit (Hold-down circuit) Check” should always be performed when replacing the following components marked with and on the schematic diagram.

### D board

- components ..... RV833, RV1603
- components ..... C519, C843, C844, C845, C846, C847, C848, C1601, C1602, D835, D836, D1601, D1603, IC502, Q833, Q834, Q835, Q836, Q1601, Q1602, Q1603, R523, R850, R851, R852, R853, R854, R855, R856, R857, R858, R859, R860, R861, R862, R863, R1601, R1602, R1603, R1604, R1605, R1606, R1607, R1608, R1628, R1629, R1630, RV833, RV1601, RV1603

### G board

- components ..... RV651
- components ..... C654, IC601, IC651, PH601, R653, R655, R656, R657, RV651

### P board

- components ..... C814, NL801, T802 (FBT)

## 4-1. B+ VOLTAGE CHECK

### 4-1-1. B+ Voltage Check in AC Operation

**Note:** Be sure to use the NF power supply. If not, use an ordinary variable step-up transformer of its distortion factor is 3 % or less.

Input signal: Dot pattern signal  
 Controls: BRIGHT  $\Rightarrow$  Minimum  
 CONTR  $\Rightarrow$  Minimum

1. Input 130  $^{+5}_{-0}$  Vac from the NF power supply (or variable step-up transformer of its distortion factor is 3 % or less).
2. Connect the digital voltmeter to pin 6 of RY1601 and ground on the D board.
3. Make sure that the voltage is within the following specification.

#### Specification:

RY1601 Pin-6 (D board) = 41.9 Vdc or less

4. If the above voltage is out of specification, adjust voltage with RV651 on the G board. After adjusting, be sure to apply paint to RV651.

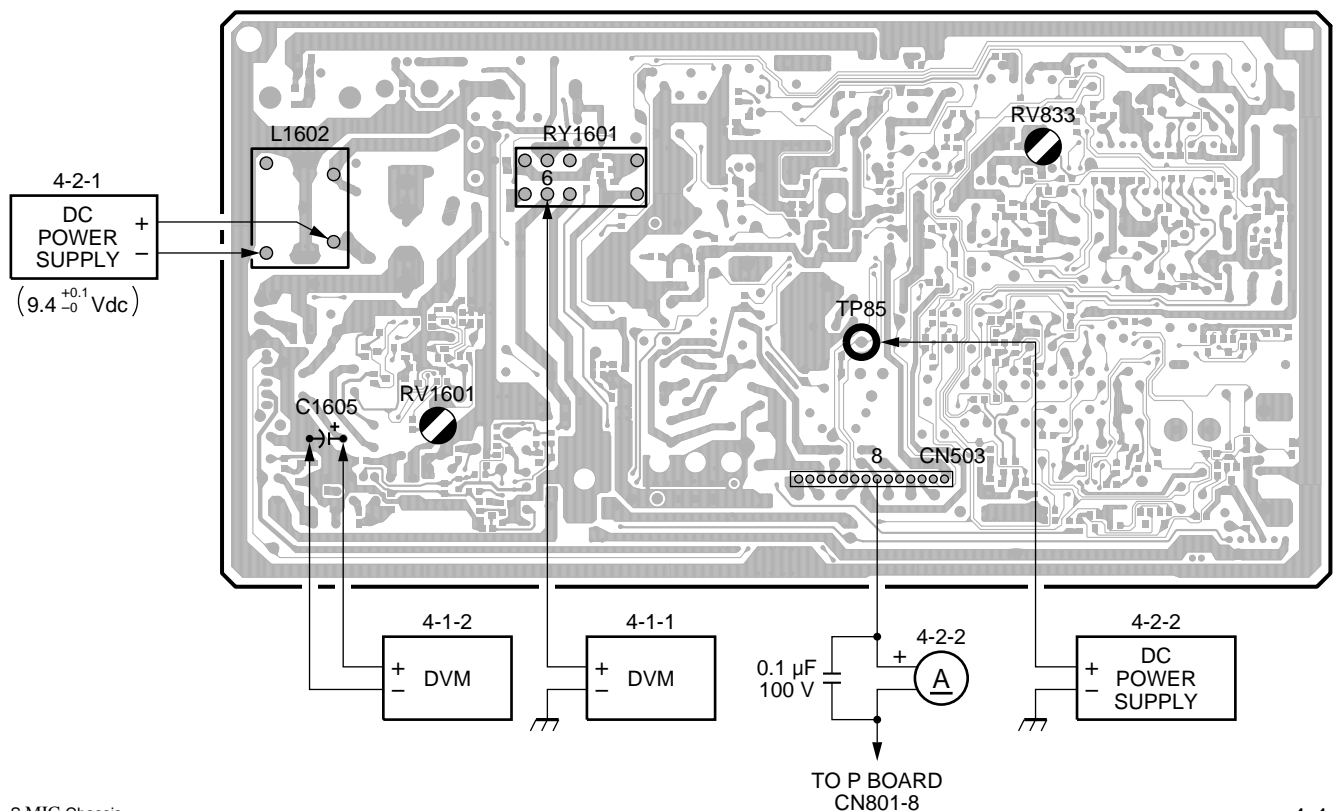

## 4-1-2. B+ Voltage Check in DC Operation

Input signal: Dot pattern signal  
Controls: BRIGHT  $\Rightarrow$  Minimum  
CONTR  $\Rightarrow$  Minimum

1. Input  $12 \pm 0.4$  Vdc from the regulated DC power supply to DC 12V IN.
2. Connect the digital voltmeter to plus (+) terminal of C1605 and ground on the D board.
3. Make sure that the voltage is within the following specification.

### Specification:

C1605 plus terminal (D board) =  $40 \pm 0.1$  Vdc or less

4. If the above voltage is out of specification, adjust voltage with RV1601 on the D board. After adjusting, be sure to apply paint to RV1601.

## 4-2. PROTECTION CIRCUIT (HOLD-DOWN CIRCUIT) CHECK

### 4-2-1. Shutdown Voltage Adjustment

Input signal: Dot pattern signal  
Controls: BRIGHT  $\Rightarrow$  Minimum  
CONTR  $\Rightarrow$  Minimum

1. Turn RV1602 on the D board and stops where the protection circuit doesn't shut down.
2. Apply voltage of  $9.4 \pm 0.1$  Vdc from the DC power supply between pin 5 of L1602 and ground on the D board.
3. Turn on the power.
4. Gradually turn RV1602 on the D board and stops where the shutdown circuit works.

### 4-2-2. Protection Circuit Operation Check

Input signal: Dot pattern signal  
Controls: BRIGHT  $\Rightarrow$  Minimum  
CONTR  $\Rightarrow$  Minimum

1. Connect (+) side of ammeter to pin 8 of CN503 on the D board and (-) side to pin 8 of CN801 on the P board.

**Note:** Connect film capacitor of  $0.1 \mu\text{F}/100 \text{ V}$  in parallel to the ammeter.

2. Adjust BRIGHT and CONTR controls of the front panel so that the reading ( $I_{ABL}$ ) on the ammeter becomes the following specification.  
**Specification:**  $I_{ABL} = 160 \pm 30 \mu\text{A}$
3. Apply  $18.4 \pm 0.1$  Vdc from the regulated DC power supply to TP85 (or pin 6 of CN503) on the D board. Adjust RV833 on the D board so that the protection circuit works.
4. Apply  $17.6 \pm 0.1$  Vdc from the regulated DC power supply to TP85 (or pin 6 of CN503) on the D board.  
**Specification:** Protection circuit becomes inoperative.
5. Input the all white signal from the test signal generator.
6. Adjust BRIGHT and CONTR controls of the front panel so that the reading ( $I_{ABL}$ ) on the ammeter becomes the following specification.  
**Specification:**  $I_{ABL} = 520 \pm 30 \mu\text{A}$
7. Apply  $17.7 \pm 0.1$  Vdc from the regulated DC power supply to TP85 (or pin 6 of CN503) on the D board.  
**Specification:** Protection circuit becomes operative.
8. Apply  $16.9 \pm 0.1$  Vdc from the regulated DC power supply to TP85 (or pin 6 of CN503) on the D board.  
**Specification:** Protection circuit becomes inoperative.
9. After the completion of steps 2 to 9, be sure to apply paint to RV833.



# SECTION 5 CIRCUIT ADJUSTMENTS

## 5-1. D BOARD ADJUSTMENTS

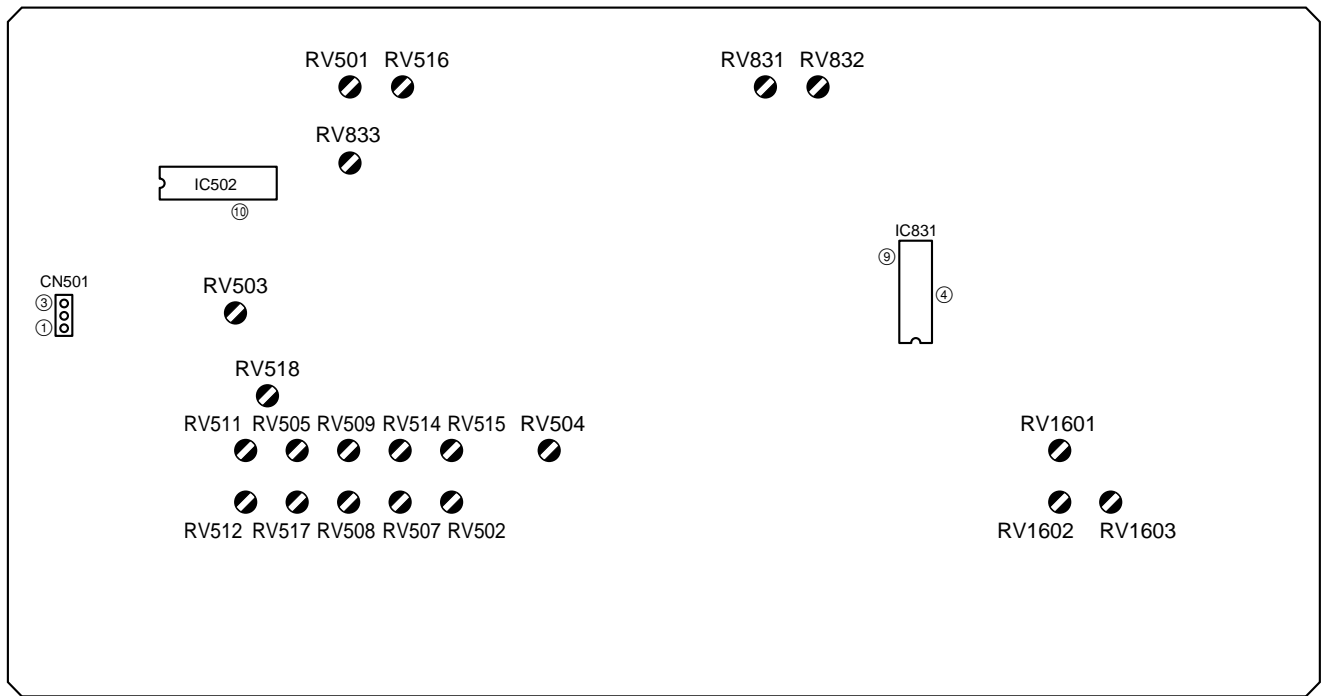

D Board Adjusting Components Location

### 5-1-1. Horizontal Oscillating Frequency Adjustment (RV503)

Input signal: Monoscope signal

1. Connect (+) side of electrolytic capacitor of 0.1  $\mu$ F/100 V to pin 1 of CN501 (or pin 1 of IC502) and (-) side to pin 3 of CN501 (or ground).
2. Connect a frequency counter to pin 10 of IC502. Adjust RV503 (H.FREQ) so that the frequency reading becomes the following specification.

**Specification:** Frequency = 15.734 kHz  $\pm$  50 Hz

3. If the frequency counter is not available, adjust RV503 so that a horizontal-hold becomes stable.

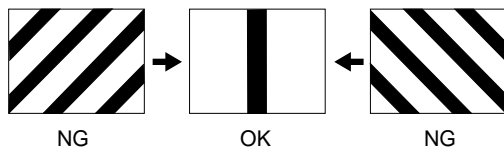

### 5-1-2. Video Phase Adjustment (RV512, RV516, RV502)

Input signal: Monoscope signal

- Switches: UNDER SCAN  $\Rightarrow$  Push (ON)  
 16 : 9  $\Rightarrow$  Pull (4 : 3)
- Controls: BRIGHT  $\Rightarrow$  Maximum  
 CONTR  $\Rightarrow$  Minimum

1. Adjust RV512 (U/H.SIZE) so that the white frame of monoscope signal is visible on the CRT screen.
2. Adjust RV516 (H.BLKG) so that the entire deflection area is visible on the CRT screen.
3. Turn RV502 (VIDEO PHASE) and make sure that the video phase is moving smoothly. Adjust RV502 so that the monoscope signal comes in the center of the signal area.

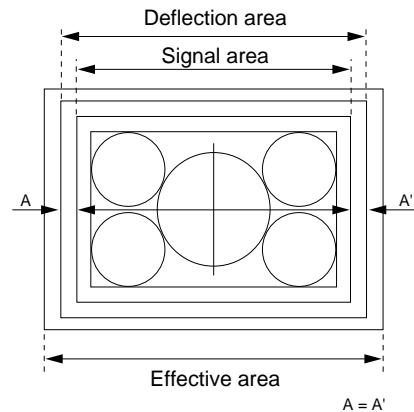

### 5-1-3. Vertical Blanking Adjustment (RV501)

Input signal: Monoscope signal  
 Switches: UNDER SCAN  $\Rightarrow$  Push (ON)  
 16 : 9  $\Rightarrow$  Pull (4 : 3)  
 Controls: BRIGHT  $\Rightarrow$  Maximum  
 CONTR  $\Rightarrow$  Minimum

1. Adjust RV501 (V.BLKG) so that the upper white frame of monoscope signal is not blanked.

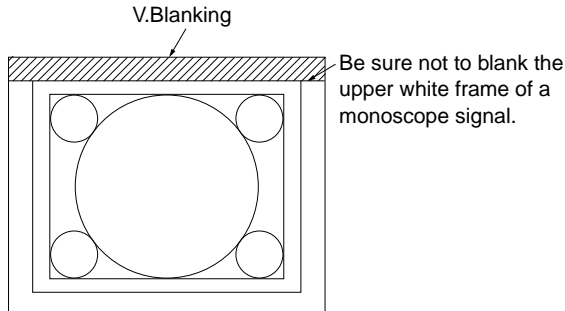

### 5-1-4. Horizontal Blanking Adjustment (RV516)

Input signal: Monoscope signal  
 Switches: UNDER SCAN  $\Rightarrow$  Push (ON)  
 16 : 9  $\Rightarrow$  Pull (4 : 3)  
 Controls: BRIGHT  $\Rightarrow$  Maximum  
 CONTR  $\Rightarrow$  Minimum

1. Adjust RV516 (H.BLKG) so that the left white frame of monoscope signal is not blanked.

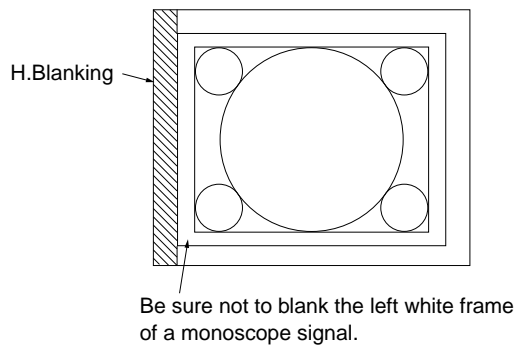

### 5-1-5. Vertical Deflection System Adjustment (RV505, RV507, RV504, RV518)

Input signal: Monoscope signal  
 Switches: UNDER SCAN  $\Rightarrow$  Pull (OFF)  
 16 : 9  $\Rightarrow$  Pull (4 : 3)  
 Controls: BRIGHT  $\Rightarrow$  50 % (Center click)  
 CONTR  $\Rightarrow$  70 %

1. Adjust RV505 (V.SIZE) so that the vertical size of monoscope signal on the CRT screen is 12 frames.

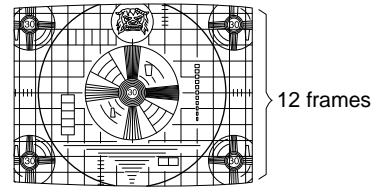

2. Adjust the vertical linearity with RV507 (V.LINE).

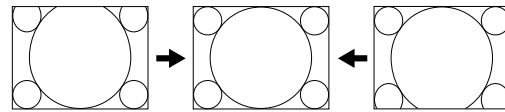

3. Adjust the vertical position with RV504 (V.CENT).

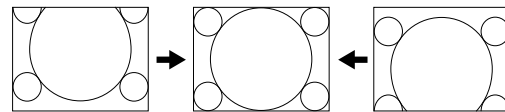

4. Press the UNDER SCAN switch of the front panel.
5. Press the 16 : 9 switch of the front panel.
6. Adjust the vertical size with RV518 (16 : 9 V.SIZE).

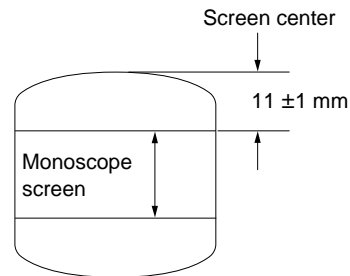

### 5-1-6. Horizontal Deflection System Adjustment (RV508, RV509, RV511, RV514, RV515, and RV801/P Board)

Input signal: Monoscope signal  
 Switches: UNDER SCAN  $\Rightarrow$  Pull (OFF)  
 16 : 9  $\Rightarrow$  Pull (4 : 3)  
 Controls: BRIGHT  $\Rightarrow$  50 % (Center click)  
 CONTR  $\Rightarrow$  70 %

1. Adjust the horizontal position with RV801 (H.CENT).

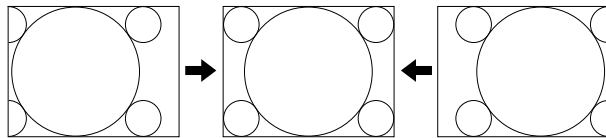

2. Adjust RV511 (H.SIZE) so that the horizontal size of monoscope signal on the CRT screen is 16 frames.

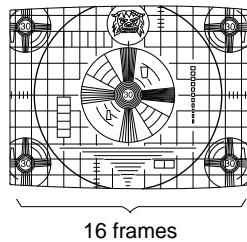

3. While adjusting vertical angular and bow distortions with RV514 (V.ANG) and RV515 (BOW), adjust RV509 (PIN AMP) and RV508 (PIN PHASE) so that the vertical lines become straight.

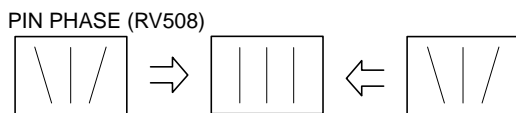
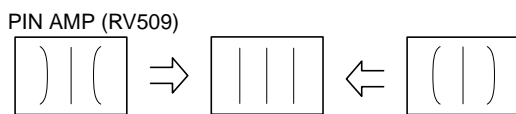
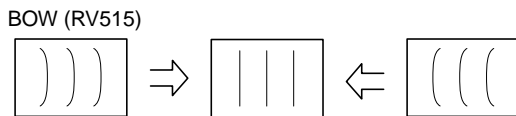
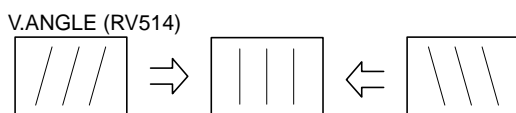

4. Adjust RV511 (H.SIZE) so that the horizontal size of monoscope signal on the CRT screen is 16 frames.

### 5-1-7. Under Scan Adjustment (RV517, RV512)

Input signal: Monoscope signal  
 Switches: UNDER SCAN  $\Rightarrow$  Push (ON)  
 16 : 9  $\Rightarrow$  Pull (4 : 3)  
 Controls: BRIGHT  $\Rightarrow$  50 % (Center click)  
 CONTR  $\Rightarrow$  70 %

1. Adjust the horizontal size and vertical size with RV517 (U/V.SIZE) and RV512 (U/H.SIZE) as shown below.

**Note:** Be careful not to wane four corners.

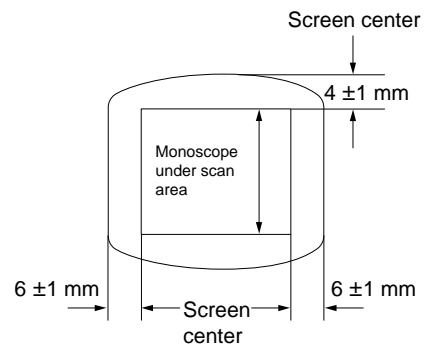

### 5-1-8. Horizontal/Vertical Delay Adjustment (RV832, RV831)

Input signal: Monoscope signal  
 Switches: UNDER SCAN  $\Rightarrow$  Push (ON)  
 16 : 9  $\Rightarrow$  Pull (4 : 3)  
 Controls: BRIGHT  $\Rightarrow$  50 % (Center click)  
 CONTR  $\Rightarrow$  70 %

1. Connect an oscilloscope to pin 4 of IC831.
2. **Horizontal Delay Adjustment (RV832)**  
Adjust the pulse width with RV832 as shown below.

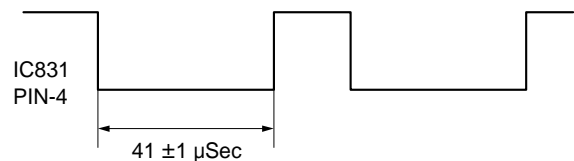

3. Connect an oscilloscope to pin 9 of IC831.
4. **Vertical Delay Adjustment (RV831)**  
Adjust the pulse width with RV831 as shown below.

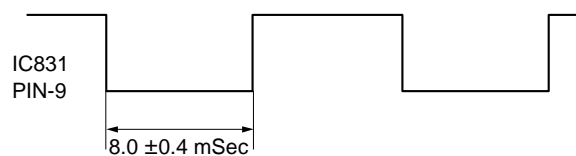

## 5-2. B BOARD ADJUSTMENTS

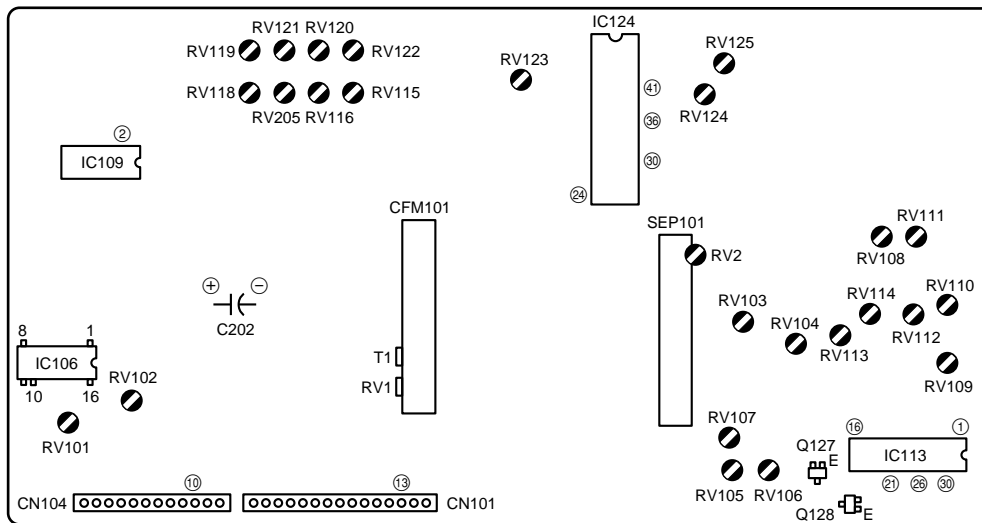

B Board Adjusting Components Location

### 5-2-1. Primary Color Matrix Adjustment (1) (RV115)

Input signal: Component color bars signal  
(75 % chroma color bars signal)

Switches: UNDER SCAN ⇒ Pull (OFF)  
16 : 9 ⇒ Pull (4 : 3)  
SYNC INT/EXT ⇒ EXT  
LINE/RGB ⇒ RGB

1. Supply a sync signal from the test signal generator to EXT SYNC IN connector of the rear panel.
2. Supply Y signal and R-Y signal from the test signal generator to RGB/COMPONENT connector of the rear panel.
3. Connect an oscilloscope to pin 30 (B OUT) of IC124.
4. Adjust RV115 (SUB HUE) to minimize (15 mVp-p or less) the B signal level.

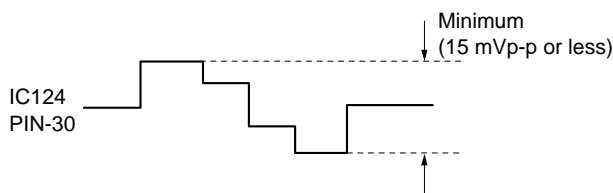

### 5-2-2. Primary Color Matrix Adjustment (2) (RV116, RV123)

Input signal: Component color bars signal  
(75 % chroma color bars signal)

Switches: UNDER SCAN ⇒ Pull (OFF)  
16 : 9 ⇒ Pull (4 : 3)  
SYNC INT/EXT ⇒ INT  
LINE/RGB ⇒ RGB

1. Supply Y, R-Y, and B-Y signals from the test signal generator to RGB/COMPONENT connectors.
2. Connect an oscilloscope to pin 30 (B OUT) of IC124.
3. Adjust RV116 (SUB COL) to minimize each peak level (20 mVp-p or less). Adjust so that the 1st and the 4th peaks should have the same level.

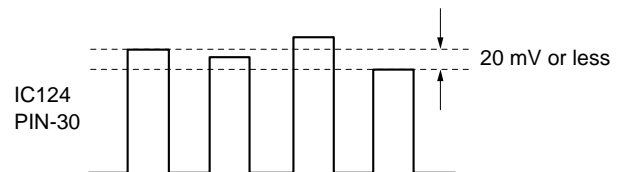

4. Connect an oscilloscope to pin 41 (R OUT) of IC124.
5. Adjust RV123 (MATRIX R-Y) so that the level difference of R signal is shown below.

#### Specification:

Level difference of B and D = Minimum (20 mV or less)

Level difference of B and C = Minimum (30 mV or less)

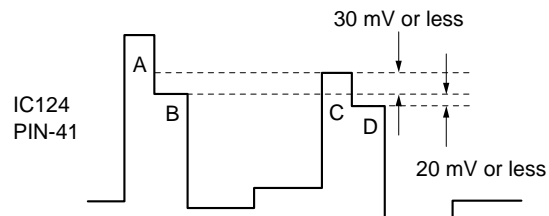

### 5-2-3. Burst Gate Pulse Width Adjustment (RV109)

Input signal: Color bars signal (LINE A/VIDEO IN)  
 Switches: UNDER SCAN ⇒ Pull (OFF)  
 16 : 9 ⇒ Pull (4 : 3)  
 SYNC INT/EXT ⇒ INT  
 LINE/RGB ⇒ LINE

1. Connect an oscilloscope to pin 10 (COMP SYNC) of CN104 and pin 1 (BGP GEN) of IC113.
2. Adjust the pulse width (T) with RV109 (BGP WIDTH) as shown below.

**Specification:**  $T = 7.8 \pm 0.2 \mu\text{sec}$

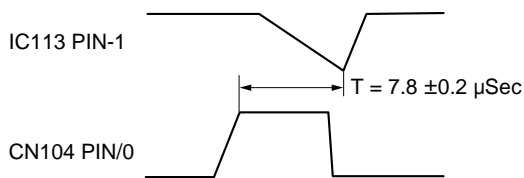

### 5-2-4. NTSC Subcarrier Frequency Adjustment (RV1400)

Input signal: NTSC Color bars signal (LINE A/VIDEO IN)  
 Switches: UNDER SCAN ⇒ Pull (OFF)  
 16 : 9 ⇒ Pull (4 : 3)  
 SYNC INT/EXT ⇒ INT  
 LINE/RGB ⇒ LINE

1. Apply +5 V to pin 26 of IC113 via 4.7 kΩ resistor.
2. Connect pin 2 of IC109 to ground.
3. Connect the following circuit to pin 1 of IC113.

#### Part Required

Resistor 18 kΩ ..... 1 pc  
 Diode 1S133 ..... 4 pcs

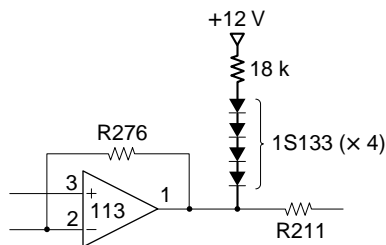

4. Connect the frequency counter to pin 21 of IC113.
5. Adjust the frequency with RV1400 (3.58 F0).

**Specification:**  $F_0 = 3,579,545 \pm 20 \text{ Hz}$

### 5-2-5. PAL Subcarrier Frequency Adjustment (RV1401)

Input signal: PAL Color bars signal (LINE A/VIDEO IN)  
 Switches: UNDER SCAN ⇒ Pull (OFF)  
 16 : 9 ⇒ Pull (4 : 3)  
 SYNC INT/EXT ⇒ INT  
 LINE/RGB ⇒ LINE

1. Apply +5 V to pin 26 of IC113 via 4.7 kΩ resistor.
2. Connect pin 2 of IC109 to +12 V line.
3. Connect the following circuit to pin 1 of IC113.

#### Part Required

Resistor 18 kΩ ..... 1 pc  
 Diode 1S133 ..... 4 pcs

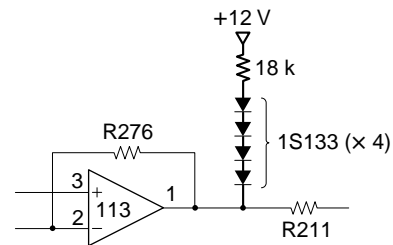

4. Connect the frequency counter to pin 21 of IC113.
5. Adjust the frequency with RV1401 (4.43 F0).

**Specification:**  $F_0 = 4,433,619 \pm 20 \text{ Hz}$

### 5-2-6. NTSC Comb Filter Adjustment (RV1, T1/CFM101)

Input signal: NTSC Color bars signal (LINE A/VIDEO IN)  
 Switches: UNDER SCAN ⇒ Pull (OFF)  
 16 : 9 ⇒ Pull (4 : 3)  
 SYNC INT/EXT ⇒ INT  
 LINE/RGB ⇒ LINE

1. Connect an oscilloscope to minus (-) terminal of capacitor C202, and confirm the Y and residual chroma levels.

#### Specification:

Y level =  $0.78 \pm 0.05 \text{ V}_{p-p}$   
 Residual chroma level =  $32 \text{ mV}_{p-p}$  or less

2. If the residual chroma level is out of specification, adjust RV1 and T1 alternately so that it is minimum.

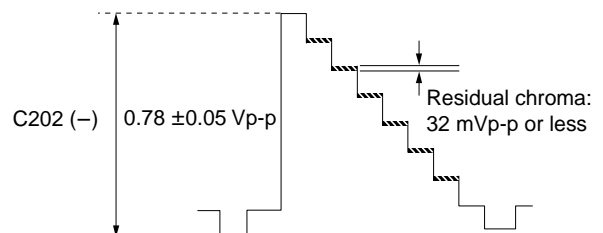

### 5-2-7. NTSC 3.58 MHz Color Demodulation (B-Y) Adjustment (RV114, RV111)

Input signal: 3.58 MHz NTSC 75 % Color bars signal  
(Set Y and B-Y of test signal generator to off.)

Switches: SYNC INT/EXT  $\Rightarrow$  INT  
LINE/RGB  $\Rightarrow$  LINE

1. Connect an oscilloscope to emitter of Q128.
2. Adjust RV114 (3.58 NTSC HUE) so that the level other than the burst portion is flat (Voltage difference = 10 mV or less).
3. Set Y and B-Y of test signal generator to on.
4. Connect an oscilloscope to pin 30 of IC124.
5. Adjust RV111 (3.58 NTSC COL) so that the level difference of B signal is minimum (20 mVp-p or less). Adjust so that the 1st and the 4th peaks should have the same level.

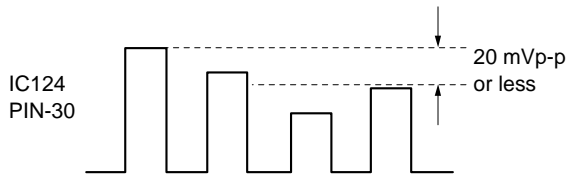

### 5-2-8. NTSC 3.58 MHz Color Demodulation (R-Y) Adjustment (RV104, RV107)

Input signal: 3.58 MHz NTSC 75 % Color bars signal  
(Set Y and R-Y of test signal generator to off.)

Switches: SYNC INT/EXT  $\Rightarrow$  INT  
LINE/RGB  $\Rightarrow$  LINE

1. Connect an oscilloscope to emitter of Q127.
2. Adjust RV104 (3.58 NTSC SHIFT) so that the R level is flat (Voltage difference =  $\pm 15$  mV or less).
3. Set Y and R-Y of test signal generator to on.
4. Connect an oscilloscope to pin 41 of IC124.
5. Adjust RV107 (3.58 NTSC COL) so that the level difference of R signal is minimum.

#### Specification:

Level difference of B and D = Minimum (20 mV or less)

Level difference of B and C = Minimum (60 mV or less)

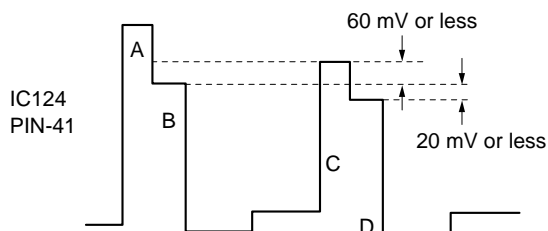

6. After adjustment, perform section "5-2-7. NTSC 3.58 MHz Color Demodulation (B-Y) Adjustment" again.

### 5-2-9. NTSC 4.43 MHz Color Demodulation Adjustment (RV108, RV112)

Input signal: 4.43 MHz NTSC 75 % Color bars signal  
(Set Y and B-Y of test signal generator to off.)

Switches: SYNC INT/EXT  $\Rightarrow$  INT  
LINE/RGB  $\Rightarrow$  LINE

1. Connect an oscilloscope to pin 30 of IC124.
2. Adjust RV108 (4.43 NTSC COL) so that the level is flat (Voltage difference = 25 mV or less).

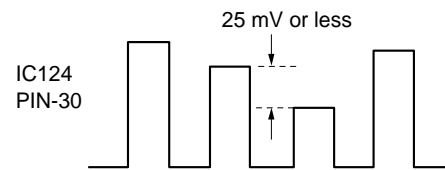

3. If cyan and magenta levels are different, adjust RV112 (4.43 NTSC HUE) and RV108 (4.43 NTSC COL) alternately.

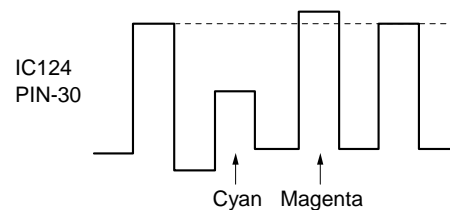

4. Connect an oscilloscope to emitter of Q127.
5. Adjust RV103 (4.43 NTSC SHIFT) so that the R level is flat (Voltage difference =  $\pm 15$  mV or less).
6. Connect an oscilloscope to pin 41 of IC124.
7. Adjust RV106 (4.43 NTSC COL) so that the level difference of R signal is minimum.

#### Specification:

Level difference of B and D = Minimum (20 mV or less)

Level difference of B and C = Minimum (60 mV or less)

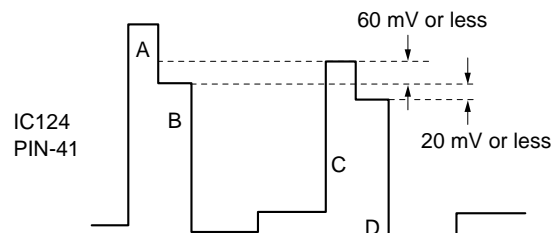

8. After adjustment, readjust from steps 1 to 7.

## 5-2-10. PAL Color Demodulation Adjustment (RV113, RV2/SEP101, RV110, RV105)

Input signal: PAL Special Color bars signal

PAL Color bars signal

Switches: SYNC INT/EXT ⇒ INT

LINE/RGB ⇒ LINE

1. Connect an oscilloscope to emitter of Q127.
2. Adjust RV113 (PAL HUE) so that the B-Y (0/180°) anti-PAL signal on the R-Y demodulated signal is flat.

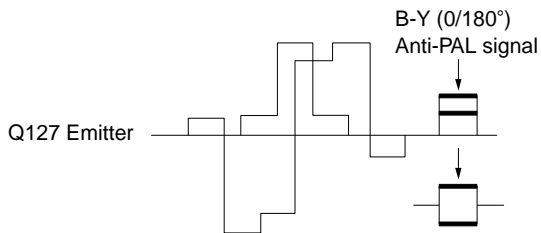

3. Connect an oscilloscope to emitter of Q128.
4. Adjust RV2 on the SEP101 so that the R-Y (90/90°) anti-PAL signal on the B-Y demodulated signal is flat.

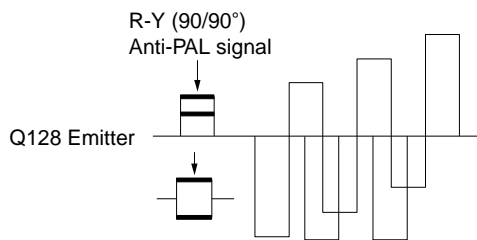

5. Turn CHROMA control of the front panel maximum clockwise, and make sure of no color is visible at the anti-PAL signal portion on the CRT screen.
6. Input the PAL color bars signal.
7. Connect an oscilloscope to pin 30 of IC124.
8. Adjust RV110 (PAL COL) to minimize each peak level.

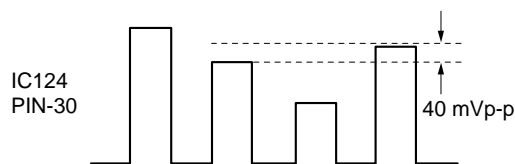

9. Connect an oscilloscope to pin 41 of IC124.
10. Adjust RV105 (PAL COL) so that the level difference of R signal is minimum.

### Specification:

Level difference of B and D = Minimum (20 mV or less)

Level difference of B and C = Minimum (60 mV or less)

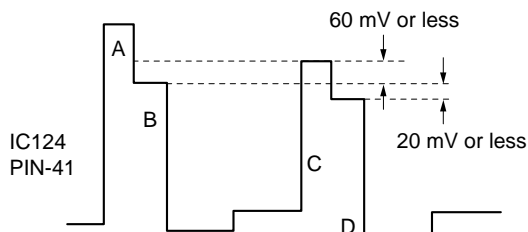

11. After adjustment, readjust from steps 7 to 10.

S MIC Chassis

## 5-2-11. Sub-Sharpness Adjustment (RV205)

Input signal: Sweep signal

Bandwidth: 10 MHz or more (flat)

Burst: OFF

Composite Sync: ON

Switches: SYNC INT/EXT ⇒ INT

LINE/RGB ⇒ LINE

1. Connect an oscilloscope to pin 36 of IC124.
2. Adjust RV205 (SUB SHARP) so that the 0.5 MHz and 6 MHz portions of the sweep signal is equal level ( $0 \pm 0.5$  dB).

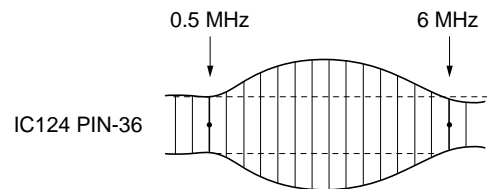

## 5-2-12. Chroma H Pulse Adjustment (RV101, RV102)

Input signal: SECAM Color Bars signal

Switches: SYNC INT/EXT ⇒ INT

LINE/RGB ⇒ LINE

1. Connect an oscilloscope to pin 10 of IC106 and pin 13 of CN101.
2. Adjust RV101 (PULSE WIDTH) so that the pulse width is shown in the following specification.

**Specification:** Pulse width =  $6.4 \pm 0.3 \mu\text{s}$

**Note:** No adjustment is required for the PAL-M model.

3. Adjust RV102 (PULSE POSI) so that the phase difference of H sync to chroma H pulse is shown in the following specification.

**Specification:** Phase difference =  $0 \pm 0.5 \mu\text{s}$

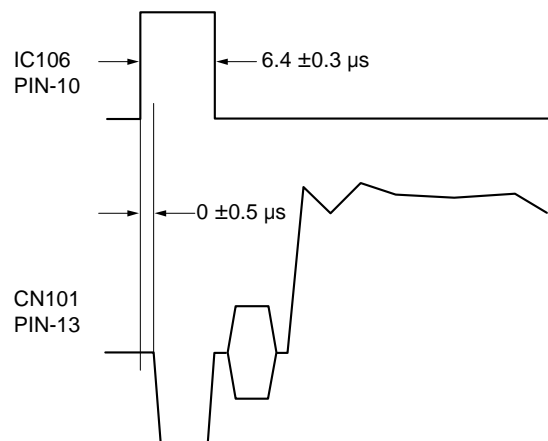

### 5-3. S BOARD ADJUSTMENTS

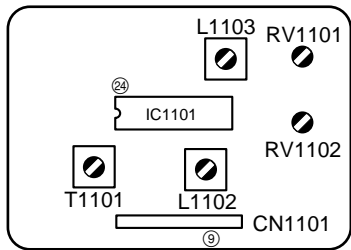

S Board Adjusting Components Location

#### 5-3-1. SECAM Bell Filter Adjustment (T1101)

Input signal: SECAM color bars signal  
 Switches: SYNC INT/EXT  $\Rightarrow$  INT  
 LINE/RGB  $\Rightarrow$  LINE

1. Connect an oscilloscope to pin 24 of IC1101.
2. Adjust T1101 (BELL FILTER) so that the envelope of chroma signal is flat.

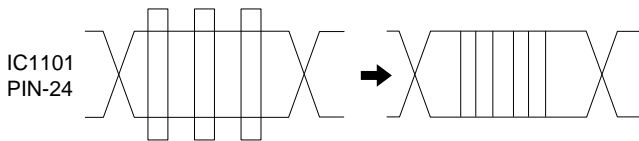

#### 5-3-2. SECAM Color Balance Adjustment (L1102, L1103)

Input signal: SECAM color bars signal  
 Switches: SYNC INT/EXT  $\Rightarrow$  INT  
 LINE/RGB  $\Rightarrow$  LINE

1. Connect an oscilloscope to pin 9 of CN1101.
2. Adjust L1102 so that no chroma component (no colored) portions of R-Y signal is flat.

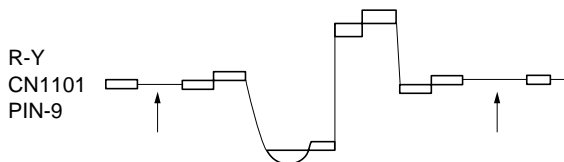

3. Adjust L1103 so that no chroma component (no colored) portions of B-Y signal is flat.

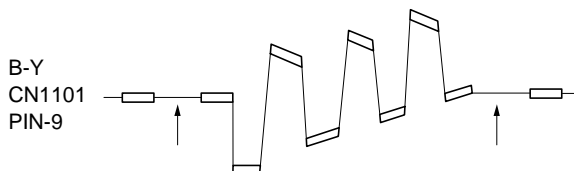

#### 5-3-3. SECAM Demodulation Level Adjustment (RV1101, RV1102)

Input signal: SECAM color bars signal  
 Switches: SYNC INT/EXT  $\Rightarrow$  INT  
 LINE/RGB  $\Rightarrow$  LINE

1. Connect an oscilloscope to pin 30 of IC124 on the B board.
2. Adjust RV1101 (SECAM COL) so that the peak level difference of B signal is minimum (20 mVp-p or less). Adjust so that the 1st and the 4th peaks should have the same level.

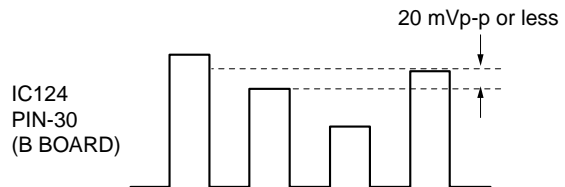

3. Connect an oscilloscope to pin 41 of IC124 on the B board.
4. Adjust RV1102 (SECAM R-Y) so that the level difference of R signal is minimum.

#### Specification:

Level difference of B and D = Minimum (20 mV or less)  
 Level difference of B and C = Minimum (60 mV or less)

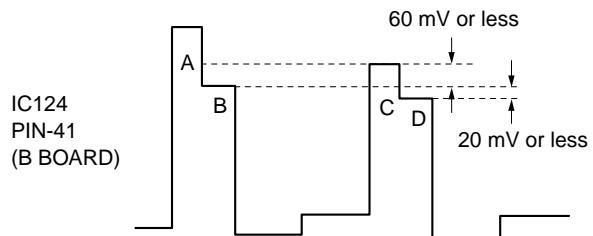



# SECTION 6 SEMICONDUCTORS

**AN5265**

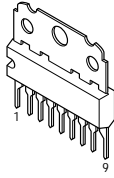

**LM358D**

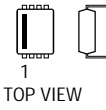

**2SA1091-0**  
**2SC2551-0**

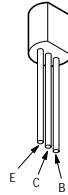

**2SD1615A-GP**

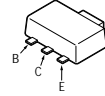

**BA10393F-E2**  
**MM1111XFBE**  
**MM1113XBE**  
**MM1114XFBE**  
**TC4W53F**

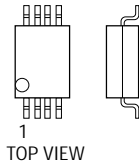

**M51279FP**

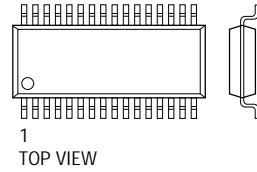

**2SA1162-G**  
**2SC1623-L5L6**  
**DTA144EK**  
**DTC124EK**  
**DTC144EK-T147**  
**DTC144EKA-T146**



**2SK94-X2X3X4**  
**2SK94-X4**

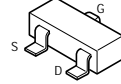

**IMH2**  
**IMX1**

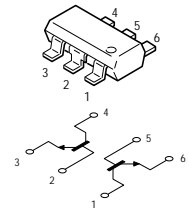

**BU4011BF-E2**  
**MC14066BF**  
**BU4070BF-E2**  
**BU4584BF-E2**

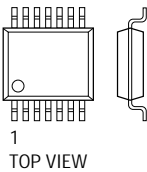

**MC14538BF**

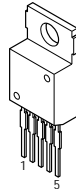

**2SC2334-L**  
**2SD1134-C**  
**2SD835**

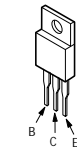

**MM1113XFBE**

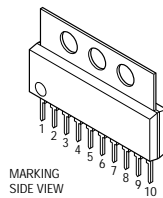

**BU4053BCF**  
**TC4052BFHB**

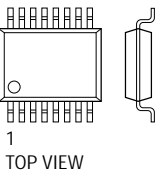

**2SC2555-2**

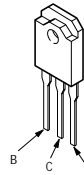

**TA7805S**  
**TA7812S**

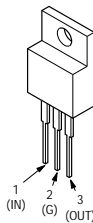

**2SC2611**  
**2SX2688-LK**

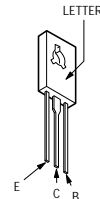

**CXA1478S**



**TC4S01F**  
**TC4S11F**  
**TC4S81F**

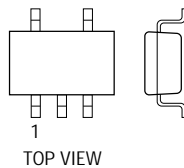

**2SC2958-L**  
**2SD774-34**

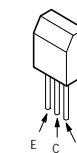

**CX23025**

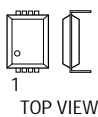

**LA7830**

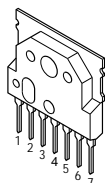

**UPC1377**

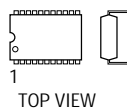

# DIODE

**1S2836**

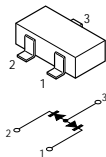

**CR02AM-4TB**

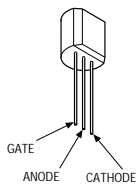

**1SS119-25**  
**RD3.6ESB1**  
**RD5.6ESB2**  
**RD8.2ESB3**

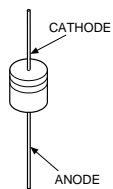

**D10C4M**

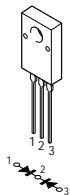

**ERC81-004**

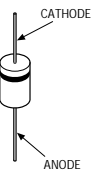

**1SS184**

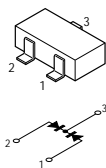

**RD6.2M-B1**

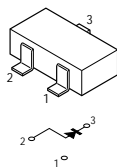

**1SS226**

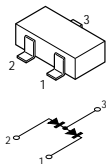

**SEL3810DLC05**  
**SLP281C-50**

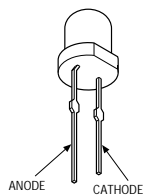

**1SS83**  
**EGP20G**  
**EL1Z**  
**GP08D**

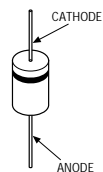

**V11N**

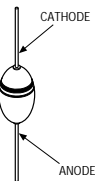

**1SV230TPH3**  
**DTZ-TT11-5.6A**  
**DTZ15B**  
**DTZ20B**  
**DTZ24B**  
**DTZ8.2B**  
**MA111**

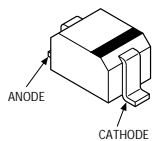

# SECTION 7

## EXPLODED VIEWS

NOTE:

- Items with no part number and no description are not stocked because they are seldom required for routine service.

### 7-1. CHASSIS

- : 7-685-646-79 +BVTP3 × 8
- ▲ : 7-685-648-79 +BVTP3 × 12

- The construction parts of an assembled part are indicated with a collation number in the remark column.
- Items marked "\*" are not stocked since they are seldom required for routine service. Some delay should be anticipated when ordering these items.

The components identified by mark  $\Delta$  are critical for safety. Replace only with part number specified.

Les composants identifiés par une marque  $\Delta$  sont critiques pour la sécurité. Ne les remplacer que par une pièce portant le numéro spécifié.

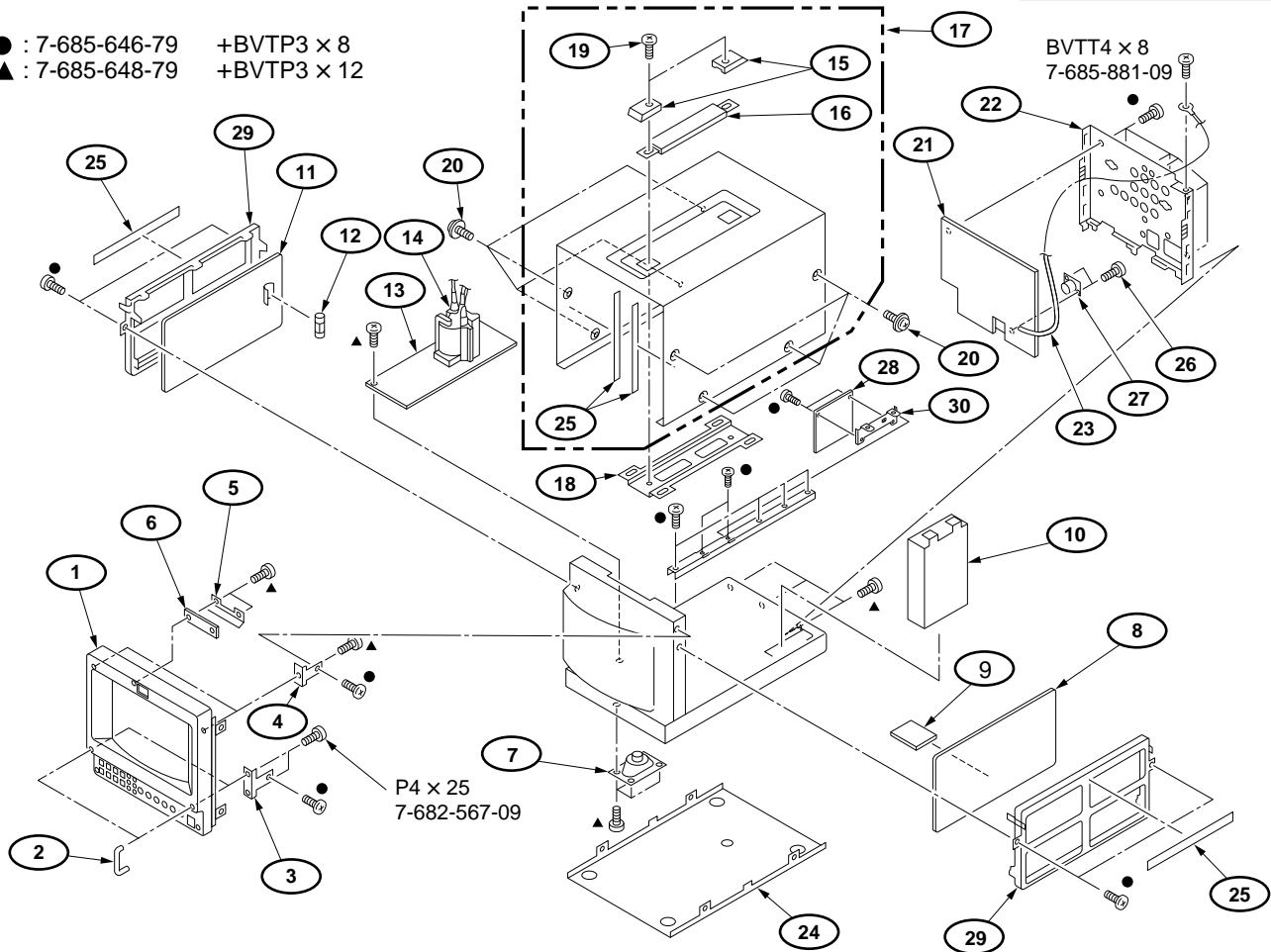

Ref.No.	Part No.	Description	Remark	Ref.No.	Part No.	Description	Remark
1	X-4036-091-1	BEZEL ASSY (PVM-8045Q, 9045QM, 9045PM)		13	* A-1195-146-A	P BOARD, COMPLETE	
1	X-4036-092-1	BEZEL ASSY (PVM-8042Q, 9042QM)		14	$\Delta$ 1-439-526-11	TRANSFORMER ASSY, FLYBACK	
2	4-037-569-01	HANDLE, PROTECTOR		15	4-034-847-01	HANDLE (BASE)	
3	* 4-034-845-01	BRACKET (L), BEZEL		16	3-419-372-31	HANDLE	
4	* 4-034-846-01	BRACKET (U), BEZEL		17	X-4030-165-7	CABINET ASSY	15, 16, 19
5	* 4-035-388-01	PLATE, LIGHT INTERCEPTION		18	* X-4030-273-1	REINFORCEMENT ASSY, HANDLE	
6	* 1-641-724-12	X BOARD		19	4-035-452-01	SCREW (M4X10)	
7	1-505-375-11	SPEAKER (4X7CM)		20	4-034-834-01	SCREW (CLAW) (4X6), CASE	
8	* A-1135-964-A	B BOARD, COMPLETE (PVM-8042Q, 8045Q)		21	* A-1275-162-A	QA BOARD, COMPLETE	
8	* A-1135-977-A	B BOARD, COMPLETE (PVM-9042QM, 9045QM)		22	* 4-034-864-81	CHASSIS, R	
8	* A-1135-981-A	B BOARD, COMPLETE (PVM-9045PM)		23	1-555-724-00	WIRE, GROUND (PVM-8042Q, 8045Q, 9045PM)	
9	* A-1394-917-A	S BOARD, COMPLETE		23	1-941-913-02	CORE, ASSY, FERRITE (PVM-9042QM, 9045PM, 9045QM)	
10	$\Delta$ 1-413-720-21	SWITCHING REGULATOR (SOPS-1021 (A))		24	* 4-034-870-02	CABINET, BOTTOM	
11	* A-1346-787-A	D BOARD, COMPLETE (PVM-8042Q, 8045Q, 9042QM, 9045QM)		25	* 4-035-691-01	CLOTH, VIBRATION PROOF	
11	* A-1346-806-A	D BOARD, COMPLETE (PVM-9045PM)		26	4-035-802-01	SCREW (M2.6X6)	
12	$\Delta$ 1-532-747-11	FUSE, GLASS TUBE (5.0A/125V) (PVM-8042Q, 8045Q, 9045PM)		27	1-900-157-02	CONNECTOR ASSY, MICRO 5P	
				28	* A-1190-333-A	PA MOUNT	
				29	* X-4030-274-1	FRAME ASSY, PWB	
12	$\Delta$ 1-576-232-11	FUSE (H.B.C) (5.0A/250V) (PVM-9042QM, 9045QM)		30	* 4-067-394-01	HOLDER, PA PWB	

7-2. PICTURE TUBE

▲ : 7-685-648-79 +BVTP3 x 12

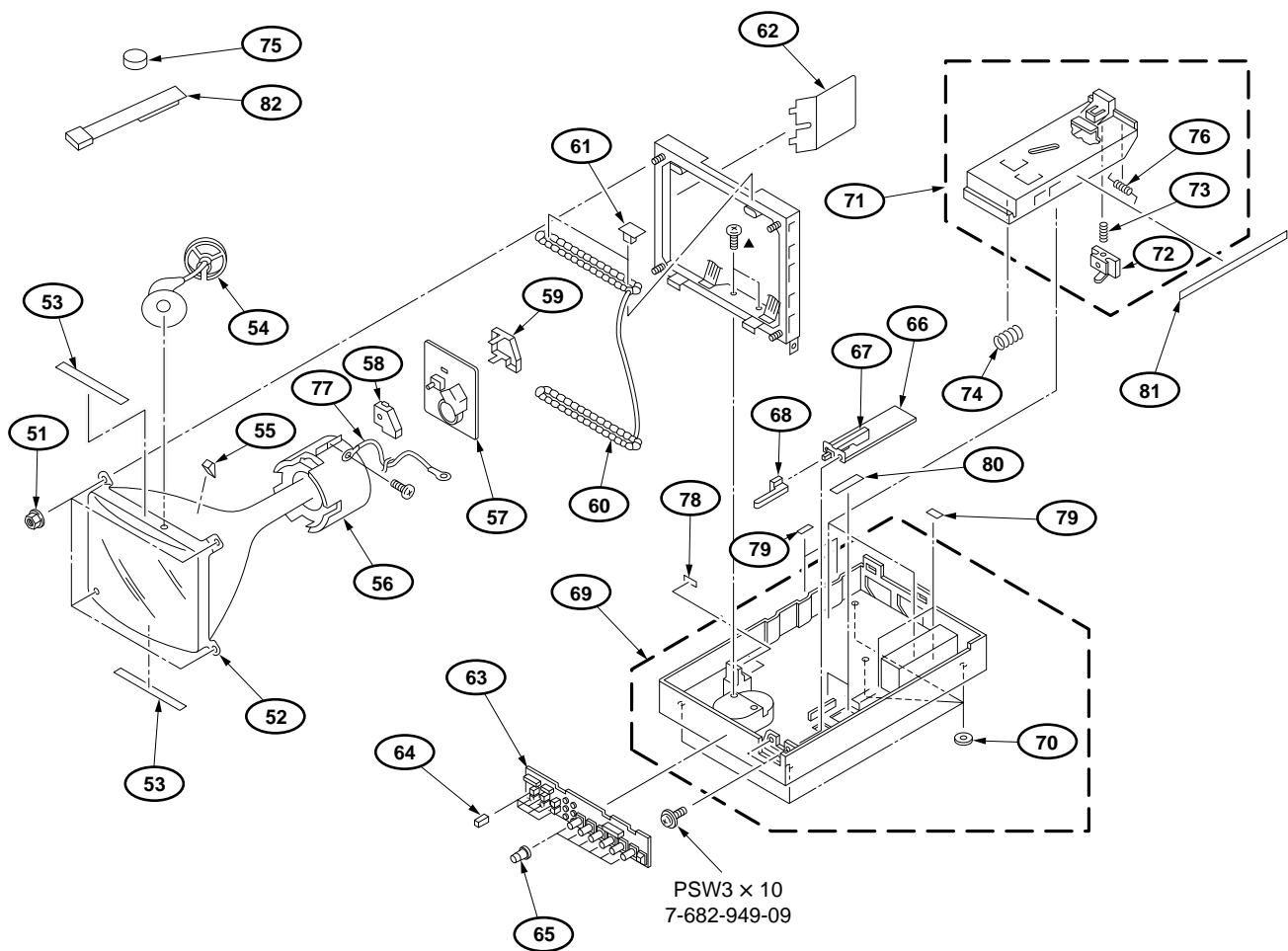

Ref.No.	Part No.	Description	Remark	Ref.No.	Part No.	Description	Remark
51	4-304-511-00	NUT (M5), FLANGE		66	* A-1241-070-A	MOUNTED PWB, FA (PVM-9042QM, 9045QM)	
52	▲8-737-154-05	PICTURE TUBE SD-167 (PVM-8042Q, 9042Q)		67	▲1-692-049-11	SWITCH, PUSH (AC POWER) (1 KEY) (3A/250V) (PVM-8042Q, 8045Q, 9045PM)	
52	▲8-737-651-05	PICTURE TUBE 09FX (PVM-8045Q, 9045PM)		67	▲1-692-050-11	SWITCH, PUSH (AC POWER) 5A/250V (PVM-8042QM, 9045QM)	
53	4-035-332-01	CLOTH, PROTECTION		68	4-034-841-11	BUTTON, POWER SWITCH	
54	* 4-034-856-01	HOLDER, HV CABLE		69	* X-4036-112-2	CHASSIS ASSY, BOTTOM	
55	4-309-369-00	SPACER, DEFLECTION YOKE		70	4-034-840-01	RUBBER, FOOT	
56	▲1-451-319-22	DEFLECTION YOKE (Y9FXC)		71	* X-4030-163-1	GUIDE ASSY, BATTERY	
57	* A-1331-183-B	CA BOARD, COMPLETE		72	4-034-861-01	KNOB, BATTERY	
58	* 4-376-133-11	COVER (MAIN), CV VOL		73	4-876-347-01	SPRING, COMPRESSION	
59	* 4-376-132-11	COVER (REAR LID), CV VOL		74	3-669-594-00	SPRING, COMPRESSION	
60	▲1-416-882-11	COIL, DEMAGNETIC		75	* 1-452-884-11	MAGNET	
61	4-380-534-01	CAP, DGC		76	* 3-669-592-00	SPRING (A), TORSION	
62	* 4-034-850-01	INSULATOR		77	1-923-511-84	WIRE UL1007 AWG18 110MM BLK	
63	* A-1372-542-A	HA BOARD, COMPLETE		78	* 4-036-047-02	RUBBER, VIBRATION PROOF	
64	4-034-849-01	SWITCH (SMALL), PUSH		79	3-839-640-00	CUSHION	
65	4-043-802-02	KNOB, CONTROL		80	3-831-441-11	CUSHION (F)	
66	* A-1241-055-A	MOUNTED PWB, FA (PVM-8042Q, 8045Q, 9045PM)		81	* 4-035-691-01	CLOTH, VIBRATION PROOF	
				82	4-051-735-22	PIECE A (75), CONV. CORRECT	

# SECTION 8

## ELECTRICAL PARTS LIST

### NOTE:

The components identified by mark  $\triangle$  are critical for safety. Replace only with part number specified.

Les composants identifiés par une marque  $\triangle$  sont critiques pour la sécurité. Ne les remplacer que par une pièce portant le numéro spécifié.

- Items marked “\*” are not stocked since they are seldom required for routine service. Some delay should be anticipated when ordering these items.
- All variable and adjustable resistors have characteristic curve B, unless otherwise noted.

### RESISTORS

- All resistors are in ohms
- F: nonflammable

When indicating parts by reference number, please include the board name.

### CAPACITORS

PF:  $\mu\mu\text{F}$

- There are some cases the reference number on one board overlaps on the other board. Therefore, when ordering parts by the reference number, please include the board name.
- The components identified by  $\boxtimes$  in this manual have been carefully factory-selected for each set in order to satisfy regulations regarding X-ray radiation. Should replacement be required, replace only with the value originally used.



Ref.No.	Part No.	Description	Remark	Ref.No.	Part No.	Description	Remark
	* A-1135-964-A	B BOARD, COMPLETE (PVM-8042Q, 8045Q)		C142	1-163-031-11	CERAMIC CHIP 0.01μF	50V
	* A-1135-977-A	B BOARD, COMPLETE (PVM-9042QM, 9045QM)		C143	1-163-121-00	CERAMIC CHIP 150PF	5% 50V
	* A-1135-981-A	B BOARD, COMPLETE (PVM-9045PM) *****		C144	1-163-101-00	CERAMIC CHIP 22PF	5% 50V
		<BAND PASS FILTER>		C145	1-163-131-00	CERAMIC CHIP 390PF	5% 50V
BPF101	1-236-363-11	FILTER, BAND PASS		C146	1-126-157-11	ELECT 10μF	20% 16V
BPF102	1-236-363-11	FILTER, BAND PASS (PVM-9045PM)		C147	1-163-021-91	CERAMIC CHIP 0.01μF	10% 50V
BPF102	1-236-364-11	FILTER, BAND PASS (PVM-8042Q, 8045Q, 9042QM, 9045QM)		C148	1-126-160-11	ELECT 1μF	20% 50V
		<CAPACITOR>		C149	1-163-022-00	CERAMIC CHIP 0.012μF	10% 50V
C101	1-124-589-11	ELECT 47μF	20% 16V	C150	1-124-589-11	ELECT 47μF	20% 16V
C102	1-163-031-11	CERAMIC CHIP 0.01μF	50V	C151	1-163-131-00	CERAMIC CHIP 390PF	5% 50V
C103	1-126-157-11	ELECT 10μF	20% 16V	C152	1-163-101-00	CERAMIC CHIP 22PF	5% 50V
C104	1-163-031-11	CERAMIC CHIP 0.01μF (PVM-8042Q, 8045Q, 9042QM, 9045QM)	50V	C153	1-163-259-91	CERAMIC CHIP 220PF	5% 50V
C105	1-163-031-11	CERAMIC CHIP 0.01μF (PVM-8042Q, 8045Q, 9042QM, 9045QM)	50V	C154	1-163-031-11	CERAMIC CHIP 0.01μF	50V
C106	1-104-664-11	ELECT 47μF	20% 16V	C155	1-163-133-00	CERAMIC CHIP 470PF	5% 50V
C107	1-163-031-11	CERAMIC CHIP 0.01μF	50V	C156	1-164-299-11	CERAMIC CHIP 0.22μF	10% 25V
C108	1-104-664-11	ELECT 47μF	20% 16V	C157	1-163-229-11	CERAMIC CHIP 12PF (PVM-8042Q, 8045Q, 9042QM, 9045QM)	5% 50V
C109	1-104-664-11	ELECT 47μF	20% 16V	C158	1-104-664-11	ELECT 47μF	20% 16V
C110	1-104-666-11	ELECT 220μF	20% 16V	C159	1-163-229-11	CERAMIC CHIP 12PF	5% 50V
C111	1-163-031-11	CERAMIC CHIP 0.01μF	50V	C160	1-163-229-11	CERAMIC CHIP 12PF	5% 50V
C112	1-163-031-11	CERAMIC CHIP 0.01μF	50V	C161	1-124-902-00	ELECT 0.47μF	20% 50V
C113	1-163-031-11	CERAMIC CHIP 0.01μF	50V	C162	1-124-903-11	ELECT 1μF	20% 50V
C114	1-104-664-11	ELECT 47μF	20% 16V	C163	1-163-809-11	CERAMIC CHIP 0.047μF	10% 25V
C115	1-163-031-11	CERAMIC CHIP 0.01μF (PVM-8042Q, 8045Q, 9042QM, 9045QM)	50V	C164	1-163-809-11	CERAMIC CHIP 0.047μF	10% 25V
C116	1-124-589-11	ELECT 47μF	20% 16V	C165	1-163-009-11	CERAMIC CHIP 0.001μF	10% 50V
C117	1-124-589-11	ELECT 47μF	20% 6.3V	C166	1-163-031-11	CERAMIC CHIP 0.01μF	50V
C118	1-124-589-11	ELECT 47μF	20% 6.3V	C167	1-104-664-11	ELECT 47μF	20% 16V
C119	1-163-031-11	CERAMIC CHIP 0.01μF	50V	C168	1-163-031-11	CERAMIC CHIP 0.01μF	50V
C120	1-124-589-11	ELECT 47μF	20% 6.3V	C169	1-163-243-11	CERAMIC CHIP 47PF	5% 50V
C121	1-124-589-11	ELECT 47μF	20% 6.3V	C170	1-163-129-00	CERAMIC CHIP 330PF	5% 50V
C122	1-104-664-11	ELECT 47μF	20% 16V	C171	1-163-243-11	CERAMIC CHIP 47PF	5% 50V
C123	1-163-031-11	CERAMIC CHIP 0.01μF	50V	C172	1-163-129-00	CERAMIC CHIP 330PF	5% 50V
C124	1-163-031-11	CERAMIC CHIP 0.01μF	50V	C173	1-124-589-11	ELECT 47μF	20% 16V
C125	1-124-589-11	ELECT 47μF	20% 6.3V	C174	1-104-664-11	ELECT 47μF	20% 16V
C126	1-163-031-11	CERAMIC CHIP 0.01μF	50V	C175	1-104-987-11	MYLAR 0.001μF	5% 50V
C127	1-124-589-11	ELECT 47μF	20% 6.3V	C176	1-163-031-11	CERAMIC CHIP 0.01μF	50V
C128	1-124-589-11	ELECT 47μF	20% 6.3V	C177	1-163-031-11	CERAMIC CHIP 0.01μF	50V
C129	1-163-031-11	CERAMIC CHIP 0.01μF	50V	C178	1-163-031-11	CERAMIC CHIP 0.01μF	50V
C130	1-163-031-11	CERAMIC CHIP 0.01μF	50V	C179	1-126-160-11	ELECT 1μF	20% 50V
C131	1-163-031-11	CERAMIC CHIP 0.01μF	50V	C180	1-163-031-11	CERAMIC CHIP 0.01μF	50V
C132	1-124-589-11	ELECT 47μF	20% 16V	C181	1-124-589-11	ELECT 47μF	20% 6.3V
C133	1-124-589-11	ELECT 47μF	20% 16V	C182	1-124-259-11	ELECT 4.7μF	20% 16V
C134	1-163-275-11	CERAMIC CHIP 0.001μF (PVM-8042Q, 8045Q, 9042QM, 9045QM)	5% 50V	C183	1-163-021-91	CERAMIC CHIP 0.01μF	10% 50V
C135	1-163-113-00	CERAMIC CHIP 68PF (PVM-8042Q, 8045Q, 9042QM, 9045QM)	5% 50V	C184	1-163-031-11	CERAMIC CHIP 0.01μF	50V
C137	1-163-249-11	CERAMIC CHIP 82PF	5% 50V	C185	1-163-031-11	CERAMIC CHIP 0.01μF	50V
C138	1-124-589-11	ELECT 47μF	20% 16V	C186	1-163-233-11	CERAMIC CHIP 18PF	5% 50V
C139	1-163-031-11	CERAMIC CHIP 0.01μF	50V	C187	1-163-031-11	CERAMIC CHIP 0.01μF	50V
C140	1-163-205-00	CERAMIC CHIP 0.001μF	5% 50V	C188	1-163-031-11	CERAMIC CHIP 0.01μF	50V
C141	1-163-141-00	CERAMIC CHIP 0.001μF	5% 50V	C189	1-163-035-00	CERAMIC CHIP 0.047μF	50V
				C190	1-163-121-00	CERAMIC CHIP 150PF (PVM-8042Q, 8045Q, 9042QM, 9045QM)	5% 50V
				C192	1-163-031-11	CERAMIC CHIP 0.01μF	50V
				C193	1-124-589-11	ELECT 47μF (PVM-8042Q, 8045Q, 9042QM, 9045QM)	20% 16V
				C194	1-124-589-11	ELECT 47μF	20% 16V
				C195	1-124-589-11	ELECT 47μF	20% 16V
				C196	1-124-589-11	ELECT 47μF	20% 16V
				C197	1-124-589-11	ELECT 47μF (PVM-8042Q, 8045Q, 9042QM, 9045QM)	20% 16V

Ref.No.	Part No.	Description	Remark	Ref.No.	Part No.	Description	Remark
C198	1-124-589-11	ELECT	47µF 20% 16V	C260	1-124-465-00	ELECT	0.47µF 20% 50V
C199	1-124-589-11	ELECT	47µF 20% 16V	C261	1-137-193-11	FILM	0.39µF 5% 50V
C202	1-124-589-11	ELECT	47µF 20% 16V	C262	1-124-465-00	ELECT	0.47µF 20% 50V
C203	1-124-589-11	ELECT	47µF 20% 16V	C264	1-163-123-00	CERAMIC CHIP	180PF 5% 50V
C204	1-124-589-11	ELECT	47µF 20% 16V	C265	1-163-129-00	CERAMIC CHIP	330PF 5% 50V
C205	1-163-101-00	CERAMIC CHIP	22PF 5% 50V	C266	1-107-714-11	ELECT	10µF 20% 16V
C206	1-164-298-11	CERAMIC CHIP	0.15µF 10% 25V	C267	1-107-714-11	ELECT	10µF 20% 16V
C207	1-164-298-11	CERAMIC CHIP	0.15µF 10% 25V	C268	1-104-664-11	ELECT	47µF 20% 16V
C208	1-163-101-00	CERAMIC CHIP	22PF 5% 50V	C269	1-164-004-11	CERAMIC CHIP	0.1µF 10% 25V
C209	1-164-004-11	CERAMIC CHIP	0.1µF 10% 25V	C270	1-164-004-11	CERAMIC CHIP	0.1µF 10% 25V
C210	1-124-589-11	ELECT	47µF 20% 16V	C271	1-163-809-11	CERAMIC CHIP	0.047µF 10% 25V
C211	1-124-589-11	ELECT	47µF 20% 16V	C272	1-163-129-00	CERAMIC CHIP	330PF 5% 50V
C212	1-124-589-11	ELECT	47µF 20% 16V	C273	1-163-129-00	CERAMIC CHIP	330PF 5% 50V
C213	1-124-589-11	ELECT	47µF 20% 16V	C274	1-104-664-11	ELECT	47µF 20% 16V
C214	1-126-157-11	ELECT	10µF 20% 16V	C275	1-163-119-00	CERAMIC CHIP	120PF 5% 50V
C215	1-126-157-11	ELECT	10µF 20% 16V	C277	1-163-097-00	CERAMIC CHIP	15PF 5% 50V
C216	1-126-157-11	ELECT	10µF 20% 16V	C278	1-163-809-11	CERAMIC CHIP	0.047µF 10% 25V
C217	1-163-031-11	CERAMIC CHIP	0.01µF 50V	C279	1-126-157-11	ELECT	10µF 20% 16V
C218	1-164-298-11	CERAMIC CHIP	0.15µF 10% 25V	C280	1-163-117-00	CERAMIC CHIP	100PF 5% 50V
C219	1-163-009-11	CERAMIC CHIP	0.001µF 10% 50V	C281	1-163-031-11	CERAMIC CHIP	0.01µF 50V
C220	1-163-031-11	CERAMIC CHIP	0.01µF 50V	C282	1-163-031-11	CERAMIC CHIP	0.01µF 50V
C221	1-124-903-11	ELECT	1µF 20% 50V	C283	1-163-031-11	CERAMIC CHIP	0.01µF 50V
C222	1-163-093-00	CERAMIC CHIP	10PF 5% 50V	C299	1-163-031-11	CERAMIC CHIP	0.01µF 50V
C223	1-163-031-11	CERAMIC CHIP	0.01µF 50V	C300	1-126-157-11	ELECT	10µF 20% 16V
C225	1-104-664-11	ELECT	47µF 20% 16V	C301	1-163-809-11	CERAMIC CHIP	0.047µF 10% 25V
C226	1-163-031-11	CERAMIC CHIP	0.01µF 50V	C302	1-124-589-11	ELECT	47µF 20% 16V
C227	1-163-038-91	CERAMIC CHIP	0.1µF 25V	C303	1-126-157-11	ELECT	10µF 20% 16V
C228	1-163-986-00	CERAMIC CHIP	0.027µF 10% 25V	C304	1-163-125-00	CERAMIC CHIP	220PF 5% 50V
C229	1-163-031-11	CERAMIC CHIP	0.01µF 50V	C305	1-117-378-11	FILM	1µF 5% 50V
C230	1-163-038-91	CERAMIC CHIP	0.1µF 25V	C306	1-163-115-00	CERAMIC CHIP	82PF 5% 50V
C231	1-163-986-00	CERAMIC CHIP	0.027µF 10% 25V	C307	1-163-145-00	CERAMIC CHIP	0.0015µF 5% 50V
C232	1-163-031-11	CERAMIC CHIP	0.01µF 50V	C308	1-164-004-11	CERAMIC CHIP	0.1µF 10% 25V (PVM-8042Q, 8045Q, 9042QM, 9045QM)
C233	1-163-031-11	CERAMIC CHIP	0.01µF 50V	C309	1-164-004-11	CERAMIC CHIP	0.1µF 10% 25V (PVM-8042Q, 8045Q, 9042QM, 9045QM)
C234	1-163-038-91	CERAMIC CHIP	0.1µF 25V	C310	1-164-004-11	CERAMIC CHIP	0.1µF 10% 25V (PVM-8042Q, 8045Q, 9042QM, 9045QM)
C235	1-163-986-00	CERAMIC CHIP	0.027µF 10% 25V	C312	1-163-031-11	CERAMIC CHIP	0.01µF 50V
C236	1-163-031-11	CERAMIC CHIP	0.01µF 50V	C313	1-163-115-00	CERAMIC CHIP	82PF 5% 50V
C237	1-163-031-11	CERAMIC CHIP	0.01µF 50V	C314	1-126-157-11	ELECT	10µF 20% 16V
C238	1-164-299-11	CERAMIC CHIP	0.22µF 10% 25V	C315	1-164-299-11	CERAMIC CHIP	0.22µF 10% 25V
C239	1-163-809-11	CERAMIC CHIP	0.047µF 10% 25V	C316	1-126-157-11	ELECT	10µF 20% 16V
C240	1-163-809-11	CERAMIC CHIP	0.047µF 10% 25V	C317	1-163-031-11	CERAMIC CHIP	0.01µF 50V
C241	1-163-809-11	CERAMIC CHIP	0.047µF 10% 25V	C318	1-163-095-00	CERAMIC CHIP	12PF 5% 50V
C242	1-163-113-00	CERAMIC CHIP	68PF 5% 50V	C319	1-163-095-00	CERAMIC CHIP	12PF 5% 50V
C243	1-163-031-11	CERAMIC CHIP	0.01µF 50V	C320	1-163-095-00	CERAMIC CHIP	12PF 5% 50V
C244	1-163-103-00	CERAMIC CHIP	27PF 5% 50V	C321	1-163-121-00	CERAMIC CHIP	150PF 5% 50V
C245	1-163-105-00	CERAMIC CHIP	33PF 5% 50V	C322	1-163-121-00	CERAMIC CHIP	150PF 5% 50V
C246	1-163-809-11	CERAMIC CHIP	0.047µF 10% 25V	C324	1-163-119-00	CERAMIC CHIP	120PF 5% 50V
C247	1-163-809-11	CERAMIC CHIP	0.047µF 10% 25V	C340	1-163-205-00	CERAMIC CHIP	0.001µF 5% 50V
C248	1-163-809-11	CERAMIC CHIP	0.047µF 10% 25V	C344	1-163-092-00	CERAMIC CHIP	9PF 0.25PF 50V
C249	1-104-665-11	ELECT	100µF 20% 16V	C345	1-163-109-00	CERAMIC CHIP	47PF 5% 50V
C250	1-163-017-00	CERAMIC CHIP	0.0047µF 10% 50V	C346	1-163-109-00	CERAMIC CHIP	47PF 5% 50V
C251	1-110-364-11	MYLAR	0.1µF 10% 200V	C347	1-163-109-00	CERAMIC CHIP	47PF 5% 50V
C252	1-107-638-11	ELECT	33µF 20% 160V	C1293	1-163-119-00	CERAMIC CHIP	120PF 5% 50V
C253	1-104-664-11	ELECT	47µF 20% 16V	C1294	1-163-119-00	CERAMIC CHIP	120PF 5% 50V
C254	1-163-031-11	CERAMIC CHIP	0.01µF 50V	C1295	1-163-119-00	CERAMIC CHIP	120PF 5% 50V
C255	1-104-664-11	ELECT	47µF 20% 16V	C1296	1-163-115-00	CERAMIC CHIP	82PF 5% 50V
C256	1-163-129-00	CERAMIC CHIP	330PF 5% 50V	C1297	1-163-103-00	CERAMIC CHIP	27PF 5% 50V
C257	1-163-129-00	CERAMIC CHIP	330PF 5% 50V				
C258	1-163-129-00	CERAMIC CHIP	330PF 5% 50V				
C259	1-163-031-11	CERAMIC CHIP	0.01µF 50V				



Ref.No.	Part No.	Description	Remark	Ref.No.	Part No.	Description	Remark
C1298	1-163-113-00	CERAMIC CHIP 68PF	5% 50V	D125	8-719-404-49	DIODE MA111	
C1299	1-163-093-00	CERAMIC CHIP 10PF	5% 50V	D126	8-719-404-49	DIODE MA111	
C1300	1-126-160-11	ELECT 1μF	20% 50V	D127	8-719-404-49	DIODE MA111	
C1301	1-126-160-11	ELECT 1μF	20% 50V	D128	8-719-801-78	DIODE 1SS184	
C1302	1-126-160-11	ELECT 1μF	20% 50V	D129	8-719-404-49	DIODE MA111	
C1303	1-126-160-11	ELECT 1μF	20% 50V	D130	8-719-800-76	DIODE 1SS226	
C1400	1-163-141-00	CERAMIC CHIP 0.001μF	5% 50V	D131	8-719-800-76	DIODE 1SS226	
C1401	1-163-141-00	CERAMIC CHIP 0.001μF	5% 50V	D132	8-719-800-76	DIODE 1SS226	
C1402	1-163-031-11	CERAMIC CHIP 0.01μF	50V	D133	8-719-404-49	DIODE MA111	
C1403	1-163-021-91	CERAMIC CHIP 0.01μF	10% 50V	D134	8-719-404-49	DIODE MA111	
C1404	1-164-004-11	CERAMIC CHIP 0.1μF	10% 25V	D135	8-719-404-49	DIODE MA111	
		<FILTER>		D136	8-719-404-49	DIODE MA111	
CFM101	1-464-880-11	FILTER BLOCK, COM (CFB-2)		D137	8-719-404-49	DIODE MA111	
		<CONNECTOR>		D138	8-719-404-49	DIODE MA111	
CN101	1-506-480-11	PIN, CONNECTOR 15P		D139	8-719-404-49	DIODE MA111	
CN102	* 1-564-506-11	PLUG, CONNECTOR 3P		D144	8-719-404-49	DIODE MA111	
CN103	* 1-565-503-11	CONNECTOR, BOARD TO BOARD 12P (PVM-8042Q, 8045Q, 9042QM, 9045QM)		D145	8-719-404-49	DIODE MA111	
CN104	* 1-564-011-11	PIN, CONNECTOR 12P		D146	8-719-404-49	DIODE MA111	
CN105	* 1-564-509-11	PLUG, CONNECTOR 6P		D147	8-719-404-49	DIODE MA111	
CN106	1-506-473-11	PIN, CONNECTOR 8P		D148	8-719-404-49	DIODE MA111	
CN107	1-506-478-11	PIN, CONNECTOR 13P		D149	8-719-404-49	DIODE MA111	
CN108	* 1-564-506-11	PLUG, CONNECTOR 3P		D150	8-719-404-49	DIODE MA111	
		<TRAP MODULE>		D151	8-719-404-49	DIODE MA111	
CTR101	1-236-366-11	MODULE, TRAP (PVM-8042Q, 8045Q, 9042QM, 9045QM)		D152	8-719-404-49	DIODE MA111	
CTR101	1-236-369-11	MODULE, TRAP (PVM-9045PM)		D153	8-719-977-20	DIODE DTZ8.2B	
CTR102	1-236-365-11	MODULE, TRAP (PVM-8042Q, 8045Q, 9042QM, 9045QM)		D154	8-719-404-49	DIODE MA111	
		<DIODE>		D155	8-719-404-49	DIODE MA111	
D102	8-719-404-49	DIODE MA111 (PVM-9045PM)		D156	8-719-404-49	DIODE MA111	
D103	8-719-404-49	DIODE MA111		D157	8-719-901-83	DIODE 1SS83	
D104	8-719-404-49	DIODE MA111		D158	8-719-901-83	DIODE 1SS83	
D105	8-719-404-49	DIODE MA111 (PVM-8042Q, 8045Q, 9042QM, 9045QM)		D159	8-719-901-83	DIODE 1SS83	
D106	8-719-404-49	DIODE MA111		D160	8-719-404-49	DIODE MA111	
D107	8-719-404-49	DIODE MA111		D161	8-719-404-49	DIODE MA111	
D108	8-719-404-49	DIODE MA111 (PVM-8042Q, 8045Q, 9042QM, 9045QM)		D162	8-719-404-49	DIODE MA111	
D109	8-719-404-49	DIODE MA111		D170	8-719-404-49	DIODE MA111	
D110	8-719-404-49	DIODE MA111		D185	8-719-104-34	DIODE 1S2836 (PVM-8042Q, 8045Q, 9042QM, 9045QM)	
D111	8-719-404-49	DIODE MA111		D186	8-719-801-78	DIODE 1SS184 (PVM-8042Q, 8045Q, 9042QM, 9045QM)	
D112	8-719-404-49	DIODE MA111		D187	8-719-800-76	DIODE 1SS226	
D113	8-719-404-49	DIODE MA111		D188	8-719-800-76	DIODE 1SS226	
D116	8-719-404-49	DIODE MA111 (PVM-8042Q, 8045Q, 9042QM, 9045QM)		D191	8-719-104-34	DIODE 1S2836	
D117	8-719-404-49	DIODE MA111		D285	8-719-404-49	DIODE MA111	
D120	8-719-404-49	DIODE MA111		D289	8-719-404-49	DIODE MA111	
D121	8-719-404-49	DIODE MA111 (PVM-8042Q, 8045Q, 9042QM, 9045QM)		D341	8-719-404-49	DIODE MA111	
D122	8-719-404-49	DIODE MA111		D342	8-719-104-34	DIODE 1S2836 (PVM-8042Q, 8045Q, 9042QM, 9045QM)	
D123	8-719-404-49	DIODE MA111		D343	8-719-800-76	DIODE 1SS226	
				D344	8-719-105-99	DIODE RD6.2M-B1 (PVM-8042Q, 8045Q, 9042QM, 9045QM)	
				D345	8-719-901-83	DIODE 1SS83	
				D346	8-719-901-83	DIODE 1SS83	
				D347	8-719-901-83	DIODE 1SS83	
				D348	8-719-800-76	DIODE 1SS226	
				D349	8-719-800-76	DIODE 1SS226	
				D350	8-719-800-76	DIODE 1SS226	
				D390	8-719-800-76	DIODE 1SS226 (PVM-8042Q, 8045Q, 9042QM, 9045QM)	
				D393	8-719-404-49	DIODE MA111	



Ref.No.	Part No.	Description	Remark	Ref.No.	Part No.	Description	Remark
D1400	8-719-045-70	DIODE 1SV230TPH3		L104	1-412-002-31	INDUCTOR CHIP 4.7μH	
D1401	8-719-404-49	DIODE MA111		L105	1-412-002-31	INDUCTOR CHIP 4.7μH	
		<DELAY LINE>		L106	1-410-470-11	INDUCTOR 10μH	
DL101	1-415-632-11	DELAY LINE, Y		L107	1-410-470-11	INDUCTOR 10μH	
DL102	1-415-633-11	DELAY LINE, Y		L112	1-408-613-31	INDUCTOR 68μH	
		<IC>		L113	1-410-947-31	INDUCTOR CHIP 33μH	
IC101	8-759-432-78	IC MM1111XFBE (PVM-8042Q, 8045Q, 9042QM, 9045QM)		L114	1-410-947-31	INDUCTOR CHIP 3μH	
IC102	8-759-446-66	IC MM1113XFBE		L115	1-410-947-31	INDUCTOR CHIP 33μH	
IC103	8-759-446-66	IC MM1113XFBE		L116	1-412-011-31	INDUCTOR CHIP 27μH	
IC104	8-759-446-66	IC MM1113XFBE		L117	1-412-011-31	INDUCTOR CHIP 27μH	
IC105	8-759-432-78	IC MM1111XFBE		L118	1-412-011-31	INDUCTOR CHIP 27μH	
IC106	8-759-009-51	IC MC14538BF		L252	1-410-478-11	INDUCTOR 47μH	
IC107	8-759-473-08	IC BU4584BF-E2		L300	1-410-482-31	INDUCTOR 100μH	
IC108	8-759-932-67	IC BU4053BCF		L1400	1-410-196-11	INDUCTOR CHIP 2.2μH	
IC109	8-759-473-07	IC BU4070BF-E2				<TRANSISTOR>	
IC110	8-759-932-67	IC BU4053BCF		Q101	8-729-120-28	TRANSISTOR 2SC1623-L5L6	
IC111	8-759-932-67	IC BU4053BCF		Q102	8-729-120-28	TRANSISTOR 2SC1623-L5L6	
IC112	8-759-231-53	IC TA7805S		Q103	8-729-120-28	TRANSISTOR 2SC1623-L5L6	
IC113	8-759-631-08	IC M51279FP		Q104	8-729-120-28	TRANSISTOR 2SC1623-L5L6	
IC114	8-759-208-09	IC TC4052BFHB		Q105	8-729-120-28	TRANSISTOR 2SC1623-L5L6	
IC115	8-759-208-09	IC TC4052BFHB		Q106	8-729-120-28	TRANSISTOR 2SC1623-L5L6	
IC116	8-759-008-67	IC MC14066BF		Q107	8-729-120-28	TRANSISTOR 2SC1623-L5L6	
IC117	8-759-358-46	IC MM1114XFBE		Q108	8-729-216-22	TRANSISTOR 2SA1162-G	
IC118	8-759-358-46	IC MM1114XFBE		Q109	1-801-806-11	TRANSISTOR DTC144EK-T147	
IC119	8-759-358-46	IC MM1114XFBE		Q112	8-729-120-28	TRANSISTOR 2SC1623-L5L6	
IC120	8-759-008-67	IC MC14066BF		Q113	8-729-120-28	TRANSISTOR 2SC1623-L5L6	
IC121	8-759-932-67	IC BU4053BCF		Q114	8-729-216-22	TRANSISTOR 2SA1162-G	
IC122	8-759-998-98	IC LM358D		Q115	8-729-120-28	TRANSISTOR 2SC1623-L5L6	
IC123	8-759-998-98	IC LM358D		Q116	8-729-120-28	TRANSISTOR 2SC1623-L5L6	
IC124	8-752-052-62	IC CXA1478S		Q117	8-729-216-22	TRANSISTOR 2SA1162-G	
IC125	8-759-008-67	IC MC14066BF		Q118	8-729-120-28	TRANSISTOR 2SC1623-L5L6 (PVM-8042Q, 8045Q, 9042QM, 9045QM)	
IC126	8-759-932-67	IC BU4053BCF		Q119	8-729-216-22	TRANSISTOR 2SA1162-G (PVM-8042Q, 8045Q, 9042QM, 9045QM)	
IC127	8-759-998-98	IC LM358D		Q120	8-729-216-22	TRANSISTOR 2SA1162-G	
IC128	8-759-998-98	IC LM358D (PVM-8042Q, 8045Q, 9042QM, 9045QM)		Q121	8-729-120-28	TRANSISTOR 2SC1623-L5L6	
IC129	8-759-998-98	IC LM358D		Q122	8-729-216-22	TRANSISTOR 2SA1162-G	
IC1400	8-759-242-64	IC TC4W53F		Q123	8-729-120-28	TRANSISTOR 2SC1623-L5L6	
IC1401	8-759-209-97	IC TC4S81F		Q124	8-729-216-22	TRANSISTOR 2SA1162-G	
		<CHIP CONDUCTOR>		Q125	8-729-120-28	TRANSISTOR 2SC1623-L5L6	
JR105	1-216-295-91	SHORT 0		Q126	1-801-806-11	TRANSISTOR DTC144EK-T147	
JR110	1-216-295-91	SHORT 0		Q127	8-729-216-22	TRANSISTOR 2SA1162-G	
JR113	1-216-295-91	SHORT 0 (PVM-9045PM)		Q128	8-729-216-22	TRANSISTOR 2SA1162-G	
JR133	1-216-295-91	SHORT 0		Q129	1-801-806-11	TRANSISTOR DTC144EK-T147	
JR138	1-216-295-91	SHORT 0		Q130	8-729-216-22	TRANSISTOR 2SA1162-G	
JR178	1-216-295-91	SHORT 0		Q132	8-729-216-22	TRANSISTOR 2SA1162-G	
		<COIL>		Q134	1-801-806-11	TRANSISTOR DTC144EK-T147	
L101	1-410-470-11	INDUCTOR 10μH		Q136	8-729-907-26	TRANSISTOR IMX1	
L102	1-410-090-41	INDUCTOR 18mH		Q137	8-729-907-26	TRANSISTOR IMX1	
L103	1-412-002-31	INDUCTOR CHIP 4.7μH (PVM-8042Q, 8045Q, 9042QM, 9045QM)		Q138	8-729-907-26	TRANSISTOR IMX1	
				Q139	8-729-216-22	TRANSISTOR 2SA1162-G	
				Q140	8-729-120-28	TRANSISTOR 2SC1623-L5L6	
				Q141	8-729-120-28	TRANSISTOR 2SC1623-L5L6	
				Q142	8-729-120-28	TRANSISTOR 2SC1623-L5L6	
				Q143	8-729-120-28	TRANSISTOR 2SC1623-L5L6	
				Q144	8-729-120-28	TRANSISTOR 2SC1623-L5L6	
				Q145	8-729-120-28	TRANSISTOR 2SC1623-L5L6	

Ref.No.	Part No.	Description	Remark	Ref.No.	Part No.	Description	Remark
Q146	8-729-255-12	TRANSISTOR 2SC2551-O				<RESISTOR>	
Q147	8-729-255-12	TRANSISTOR 2SC2551-O		R101	1-216-089-91	RES,CHIP 47K 5%	1/10W
Q148	8-729-216-22	TRANSISTOR 2SA1162-G		R102	1-216-025-91	RES,CHIP 100 5%	1/10W
Q149	8-729-200-17	TRANSISTOR 2SA1091-O		R103	1-216-091-00	RES,CHIP 56K 5%	1/10W
Q150	8-729-120-28	TRANSISTOR 2SC1623-L5L6		R104	1-216-061-00	RES,CHIP 3.3K 5%	1/10W
Q151	8-729-216-22	TRANSISTOR 2SA1162-G		R105	1-216-025-91	RES,CHIP 100 5%	1/10W
Q152	8-729-200-17	TRANSISTOR 2SA1091-O		R106	1-216-065-91	RES,CHIP 4.7K 5%	1/10W
Q153	8-729-120-28	TRANSISTOR 2SC1623-L5L6		R107	1-216-025-91	RES,CHIP 100 5%	1/10W
Q154	8-729-216-22	TRANSISTOR 2SA1162-G				(PVM-8042Q, 8045Q, 9042QM, 9045QM)	
Q155	8-729-200-17	TRANSISTOR 2SA1091-O		R108	1-216-113-00	RES,CHIP 470K 5%	1/10W
Q157	8-729-326-11	TRANSISTOR 2SC2611		R109	1-216-065-91	RES,CHIP 4.7K 5%	1/10W
Q158	8-729-326-11	TRANSISTOR 2SC2611		R110	1-216-049-91	RES,CHIP 1K 5%	1/10W
Q159	8-729-326-11	TRANSISTOR 2SC2611		R111	1-216-063-91	RES,CHIP 3.9K 5%	1/10W
Q160	8-729-120-28	TRANSISTOR 2SC1623-L5L6		R112	1-216-049-91	RES,CHIP 1K 5%	1/10W
Q161	8-729-216-22	TRANSISTOR 2SA1162-G		R113	1-249-401-11	CARBON 47 5%	1/4W F
Q164	1-801-806-11	TRANSISTOR DTC144EK-T147		R114	1-216-045-00	RES,CHIP 680 5%	1/10W
Q165	8-729-216-22	TRANSISTOR 2SA1162-G		R115	1-216-061-00	RES,CHIP 3.3K 5%	1/10W
Q166	8-729-216-22	TRANSISTOR 2SA1162-G		R117	1-216-073-00	RES,CHIP 10K 5%	1/10W
Q167	8-729-216-22	TRANSISTOR 2SA1162-G		R118	1-216-025-91	RES,CHIP 100 5%	1/10W
Q168	8-729-216-22	TRANSISTOR 2SA1162-G		R119	1-216-647-11	METAL CHIP 680 0.50%	1/10W
Q170	8-729-120-28	TRANSISTOR 2SC1623-L5L6		R120	1-216-647-11	METAL CHIP 680 0.50%	1/10W
Q171	8-729-120-28	TRANSISTOR 2SC1623-L5L6		R121	1-216-025-91	RES,CHIP 100 5%	1/10W
Q172	8-729-120-28	TRANSISTOR 2SC1623-L5L6		R122	1-216-083-00	RES,CHIP 27K 5%	1/10W
Q173	8-729-216-22	TRANSISTOR 2SA1162-G		R123	1-216-073-00	RES,CHIP 10K 5%	1/10W
Q174	8-729-216-22	TRANSISTOR 2SA1162-G				(PVM-8042Q, 8045Q, 9042QM, 9045QM)	
Q175	8-729-216-22	TRANSISTOR 2SA1162-G		R124	1-216-073-00	RES,CHIP 10K 5%	1/10W
Q176	8-729-216-22	TRANSISTOR 2SA1162-G		R125	1-216-083-00	RES,CHIP 27K 5%	1/10W
Q177	8-729-120-28	TRANSISTOR 2SC1623-L5L6		R126	1-216-093-00	RES,CHIP 68K 5%	1/10W
Q178	8-729-120-28	TRANSISTOR 2SC1623-L5L6		R127	1-216-037-00	RES,CHIP 330 5%	1/10W
Q179	1-801-806-11	TRANSISTOR DTC144EK-T147		R128	1-216-083-00	RES,CHIP 27K 5%	1/10W
Q189	8-729-907-26	TRANSISTOR IMX1		R129	1-216-067-00	RES,CHIP 5.6K 5%	1/10W
Q190	8-729-216-22	TRANSISTOR 2SA1162-G		R130	1-216-097-91	RES,CHIP 100K 5%	1/10W
Q191	8-729-120-28	TRANSISTOR 2SC1623-L5L6				(PVM-8042Q, 8045Q, 9042QM, 9045QM)	
Q192	8-729-120-28	TRANSISTOR 2SC1623-L5L6		R131	1-216-089-91	RES,CHIP 47K 5%	1/10W
Q193	8-729-120-28	TRANSISTOR 2SC1623-L5L6		R132	1-216-057-00	RES,CHIP 2.2K 5%	1/10W
Q194	8-729-120-28	TRANSISTOR 2SC1623-L5L6		R133	1-216-079-00	RES,CHIP 18K 5%	1/10W
Q195	8-729-216-22	TRANSISTOR 2SA1162-G		R134	1-216-645-11	METAL CHIP 560 0.50%	1/10W
Q196	8-729-120-28	TRANSISTOR 2SC1623-L5L6		R135	1-216-645-11	METAL CHIP 560 0.50%	1/10W
Q197	8-729-216-22	TRANSISTOR 2SA1162-G		R136	1-216-091-00	RES,CHIP 56K 5%	1/10W
Q198	8-729-216-22	TRANSISTOR 2SA1162-G		R137	1-216-045-00	RES,CHIP 680 5%	1/10W
Q199	8-729-216-22	TRANSISTOR 2SA1162-G		R138	1-216-657-11	METAL CHIP 1.8K 0.50%	1/10W
Q200	8-729-901-06	TRANSISTOR DTA144EK (PVM-8042Q, 8045Q, 9042QM, 9045QM)		R139	1-216-079-00	RES,CHIP 18K 5%	1/10W
Q201	8-729-216-22	TRANSISTOR 2SA1162-G		R140	1-216-653-11	METAL CHIP 1.2K 0.50%	1/10W
Q202	8-729-216-22	TRANSISTOR 2SA1162-G		R141	1-216-063-91	RES,CHIP 3.9K 5%	1/10W
Q203	8-729-216-22	TRANSISTOR 2SA1162-G		R142	1-216-073-00	RES,CHIP 10K 5%	1/10W
Q204	8-729-216-22	TRANSISTOR 2SA1162-G		R143	1-216-085-00	RES,CHIP 33K 5%	1/10W
Q205	8-729-216-22	TRANSISTOR 2SA1162-G		R145	1-216-065-91	RES,CHIP 4.7K 5%	1/10W
Q206	8-729-216-22	TRANSISTOR 2SA1162-G		R146	1-216-037-00	RES,CHIP 330 5%	1/10W
Q208	8-729-216-22	TRANSISTOR 2SA1162-G		R147	1-216-089-91	RES,CHIP 47K 5%	1/10W
Q209	8-729-255-12	TRANSISTOR 2SC2551-O		R148	1-216-671-11	METAL CHIP 6.8K 0.50%	1/10W
Q210	8-729-255-12	TRANSISTOR 2SC2551-O				(PVM-8042Q, 8045Q, 9042QM, 9045QM)	
Q211	8-729-255-12	TRANSISTOR 2SC2551-O		R155	1-216-655-11	METAL CHIP 1.5K 0.50%	1/10W
Q212	8-729-141-53	TRANSISTOR 2SK94-X2X3X4		R157	1-216-679-11	METAL CHIP 15K 0.50%	1/10W
Q299	8-729-120-28	TRANSISTOR 2SC1623-L5L6		R158	1-216-677-11	METAL CHIP 12K 0.50%	1/10W
Q1400	8-729-141-53	TRANSISTOR 2SK94-X2X3X4		R160	1-216-065-91	RES,CHIP 4.7K 5%	1/10W
Q1401	8-729-141-53	TRANSISTOR 2SK94-X2X3X4		R161	1-216-089-91	RES,CHIP 47K 5%	1/10W
						(PVM-8042Q, 8045Q, 9042QM, 9045QM)	
				R163	1-216-073-00	RES,CHIP 10K 5%	1/10W
				R164	1-216-677-11	METAL CHIP 12K 0.50%	1/10W

Ref.No.	Part No.	Description	Remark	Ref.No.	Part No.	Description	Remark
R165	1-216-107-00	RES,CHIP	270K 5% 1/10W	R218	1-216-295-91	SHORT	0
R166	1-216-681-11	METAL CHIP	18K 0.50% 1/10W	R219	1-216-043-91	RES,CHIP	560 5% 1/10W
R167	1-216-635-11	METAL CHIP	220 0.50% 1/10W	R220	1-216-043-91	RES,CHIP	560 5% 1/10W
R168	1-216-103-00	RES,CHIP	180K 5% 1/10W	R221	1-216-035-00	RES,CHIP	270 5% 1/10W
R169	1-216-033-00	RES,CHIP	220 5% 1/10W	R222	1-216-033-00	RES,CHIP	220 5% 1/10W
R170	1-216-089-91	RES,CHIP	47K 5% 1/10W	R223	1-216-073-00	RES,CHIP	10K 5% 1/10W
R171	1-216-053-00	RES,CHIP	1.5K 5% 1/10W	R224	1-216-073-00	RES,CHIP	10K 5% 1/10W
R172	1-216-043-91	RES,CHIP	560 5% 1/10W	R225	1-216-095-00	RES,CHIP	82K 5% 1/10W
R173	1-216-093-00	RES,CHIP	68K 5% 1/10W	R226	1-216-073-00	RES,CHIP	10K 5% 1/10W
R174	1-216-069-00	RES,CHIP	6.8K 5% 1/10W	R227	1-216-035-00	RES,CHIP	270 5% 1/10W
R175	1-216-057-00	RES,CHIP	2.2K 5% 1/10W	R228	1-216-065-91	RES,CHIP	4.7K 5% 1/10W
R176	1-216-065-91	RES,CHIP	4.7K 5% 1/10W	R229	1-216-113-00	RES,CHIP	470K 5% 1/10W
R177	1-216-073-00	RES,CHIP	10K 5% 1/10W	R230	1-216-081-00	RES,CHIP	22K 5% 1/10W
R178	1-216-089-91	RES,CHIP	47K 5% 1/10W	R231	1-216-113-00	RES,CHIP	470K 5% 1/10W
R179	1-216-081-00	RES,CHIP	22K 5% 1/10W	R232	1-216-105-91	RES,CHIP	220K 5% 1/10W
R180	1-216-679-11	METAL CHIP	15K 0.50% 1/10W	R233	1-216-073-00	RES,CHIP	10K 5% 1/10W
R181	1-216-071-00	RES,CHIP	8.2K 5% 1/10W	R234	1-216-041-00	RES,CHIP	470 5% 1/10W
R182	1-216-682-11	METAL CHIP	20K 0.50% 1/10W	R235	1-216-041-00	RES,CHIP	470 5% 1/10W
		(PVM-8042Q, 8045QM, 9042QM, 9045QM)		R236	1-216-077-00	RES,CHIP	15K 5% 1/10W
R182	1-216-683-11	METAL CHIP	22K 0.50% 1/10W	R237	1-216-025-91	RES,CHIP	100 5% 1/10W
		(PVM-9045PM)		R238	1-216-065-91	RES,CHIP	4.7K 5% 1/10W
R183	1-216-691-11	METAL CHIP	47K 0.50% 1/10W	R239	1-216-065-91	RES,CHIP	4.7K 5% 1/10W
R184	1-218-760-11	METAL CHIP	220K 0.50% 1/10W	R240	1-216-033-00	RES,CHIP	220 5% 1/10W
R185	1-216-073-00	RES,CHIP	10K 5% 1/10W	R241	1-216-073-00	RES,CHIP	10K 5% 1/10W
R186	1-216-113-00	RES,CHIP	470K 5% 1/10W	R242	1-216-051-00	RES,CHIP	1.2K 5% 1/10W
R187	1-216-073-00	RES,CHIP	10K 5% 1/10W	R243	1-216-113-00	RES,CHIP	470K 5% 1/10W
R188	1-216-113-00	RES,CHIP	470K 5% 1/10W	R244	1-216-065-91	RES,CHIP	4.7K 5% 1/10W
R189	1-216-103-00	RES,CHIP	180K 5% 1/10W	R245	1-216-679-11	METAL CHIP	15K 0.50% 1/10W
R190	1-216-107-00	RES,CHIP	270K 5% 1/10W	R246	1-216-103-00	RES,CHIP	180K 5% 1/10W
R191	1-216-097-91	RES,CHIP	100K 5% 1/10W	R247	1-216-093-00	RES,CHIP	68K 5% 1/10W
R192	1-216-103-00	RES,CHIP	180K 5% 1/10W	R248	1-216-095-00	RES,CHIP	82K 5% 1/10W
R193	1-216-105-91	RES,CHIP	220K 5% 1/10W	R249	1-216-109-00	RES,CHIP	330K 5% 1/10W
R194	1-216-089-91	RES,CHIP	47K 5% 1/10W	R250	1-216-101-00	RES,CHIP	150K 5% 1/10W
R195	1-216-113-00	RES,CHIP	470K 5% 1/10W	R251	1-216-105-91	RES,CHIP	220K 5% 1/10W
R196	1-216-073-00	RES,CHIP	10K 5% 1/10W	R252	1-216-101-00	RES,CHIP	150K 5% 1/10W
R197	1-216-671-11	METAL CHIP	6.8K 0.50% 1/10W	R253	1-216-101-00	RES,CHIP	150K 5% 1/10W
R198	1-216-049-91	RES,CHIP	1K 5% 1/10W			(PVM-8042Q, 8045Q, 9042QM, 9045QM)	
R199	1-216-065-91	RES,CHIP	4.7K 5% 1/10W	R256	1-216-107-00	RES,CHIP	270K 5% 1/10W
R200	1-216-065-91	RES,CHIP	4.7K 5% 1/10W	R259	1-216-073-00	RES,CHIP	10K 5% 1/10W
R201	1-216-043-91	RES,CHIP	560 5% 1/10W	R262	1-216-097-91	RES,CHIP	100K 5% 1/10W
R202	1-216-033-00	RES,CHIP	220 5% 1/10W	R264	1-216-065-91	RES,CHIP	4.7K 5% 1/10W
R203	1-216-045-00	RES,CHIP	680 5% 1/10W	R266	1-216-073-00	RES,CHIP	10K 5% 1/10W
R204	1-216-073-00	RES,CHIP	10K 5% 1/10W	R268	1-216-081-00	RES,CHIP	22K 5% 1/10W
R205	1-216-073-00	RES,CHIP	10K 5% 1/10W	R269	1-216-103-00	RES,CHIP	180K 5% 1/10W
R206	1-216-043-91	RES,CHIP	560 5% 1/10W	R270	1-216-081-00	RES,CHIP	22K 5% 1/10W
R207	1-216-045-00	RES,CHIP	680 5% 1/10W	R271	1-216-025-91	RES,CHIP	100 5% 1/10W
R208	1-216-671-11	METAL CHIP	6.8K 0.50% 1/10W	R272	1-216-103-00	RES,CHIP	180K 5% 1/10W
R209	1-216-043-91	RES,CHIP	560 5% 1/10W	R273	1-216-113-00	RES,CHIP	470K 5% 1/10W
		(PVM-8042Q, 8045Q, 9042QM, 9045QM)		R275	1-216-081-00	RES,CHIP	22K 5% 1/10W
R210	1-216-033-00	RES,CHIP	220 5% 1/10W	R276	1-216-037-00	RES,CHIP	330 5% 1/10W
		(PVM-8042Q, 8045Q, 9042QM, 9045QM)		R277	1-216-049-91	RES,CHIP	1K 5% 1/10W
R211	1-216-099-00	RES,CHIP	120K 5% 1/10W	R278	1-216-059-00	RES,CHIP	2.7K 5% 1/10W
R212	1-216-065-91	RES,CHIP	4.7K 5% 1/10W	R280	1-216-061-00	RES,CHIP	3.3K 5% 1/10W
R213	1-216-043-91	RES,CHIP	560 5% 1/10W	R281	1-216-061-00	RES,CHIP	3.3K 5% 1/10W
		(PVM-8042Q, 8045Q, 9042QM, 9045QM)		R282	1-216-037-00	RES,CHIP	330 5% 1/10W
R214	1-216-043-91	RES,CHIP	560 5% 1/10W	R283	1-216-049-91	RES,CHIP	1K 5% 1/10W
R215	1-216-127-11	RES,CHIP	1.8M 5% 1/10W	R284	1-216-059-00	RES,CHIP	2.7K 5% 1/10W
R216	1-216-043-91	RES,CHIP	560 5% 1/10W	R286	1-216-061-00	RES,CHIP	3.3K 5% 1/10W
R217	1-216-033-00	RES,CHIP	220 5% 1/10W	R287	1-216-061-00	RES,CHIP	3.3K 5% 1/10W



Ref.No.	Part No.	Description	Remark	Ref.No.	Part No.	Description	Remark
R288	1-216-037-00	RES,CHIP	330 5% 1/10W	R352	1-216-653-11	METAL CHIP	1.2K 0.50% 1/10W
R289	1-216-049-91	RES,CHIP	1K 5% 1/10W	R353	1-216-650-11	METAL CHIP	910 0.50% 1/10W
R290	1-216-059-00	RES,CHIP	2.7K 5% 1/10W	R354	1-216-653-11	METAL CHIP	1.2K 0.50% 1/10W
R292	1-216-061-00	RES,CHIP	3.3K 5% 1/10W	R355	1-216-113-00	RES,CHIP	470K 5% 1/10W
R293	1-216-061-00	RES,CHIP	3.3K 5% 1/10W	R356	1-216-113-00	RES,CHIP	470K 5% 1/10W
R295	1-216-057-00	RES,CHIP	2.2K 5% 1/10W	R357	1-216-095-00	RES,CHIP	82K 5% 1/10W
R296	1-216-659-11	METAL CHIP	2.2K 0.50% 1/10W	R358	1-216-113-00	RES,CHIP	470K 5% 1/10W
R297	1-216-659-11	METAL CHIP	2.2K 0.50% 1/10W	R359	1-216-081-00	RES,CHIP	22K 5% 1/10W
R298	1-216-065-91	RES,CHIP	4.7K 5% 1/10W	R360	1-216-089-91	RES,CHIP	47K 5% 1/10W
R300	1-216-065-91	RES,CHIP	4.7K 5% 1/10W	R363	1-216-069-00	RES,CHIP	6.8K 5% 1/10W
R301	1-216-059-00	RES,CHIP	2.7K 5% 1/10W	R364	1-216-073-00	RES,CHIP	10K 5% 1/10W
R302	1-216-113-00	RES,CHIP	470K 5% 1/10W	R365	1-216-073-00	RES,CHIP	10K 5% 1/10W
R303	1-216-065-91	RES,CHIP	4.7K 5% 1/10W	R366	1-216-244-00	RES,CHIP	82K 5% 1/8W
R304	1-216-049-91	RES,CHIP	1K 5% 1/10W	R367	1-216-244-00	RES,CHIP	82K 5% 1/8W
R305	1-216-049-91	RES,CHIP	1K 5% 1/10W	R368	1-216-055-00	RES,CHIP	1.8K 5% 1/10W
R306	1-216-089-91	RES,CHIP	47K 5% 1/10W	R369	1-216-248-00	RES,CHIP	120K 5% 1/8W
R307	1-216-033-00	RES,CHIP	220 5% 1/10W	R370	1-216-115-00	RES,CHIP	560K 5% 1/10W
R308	1-216-089-91	RES,CHIP	47K 5% 1/10W	R371	1-216-067-00	RES,CHIP	5.6K 5% 1/10W
R309	1-216-089-91	RES,CHIP	47K 5% 1/10W	R372	1-216-115-00	RES,CHIP	560K 5% 1/10W
R310	1-216-033-00	RES,CHIP	220 5% 1/10W	R374	1-216-115-00	RES,CHIP	560K 5% 1/10W
R311	1-216-089-91	RES,CHIP	47K 5% 1/10W	R375	1-216-683-11	METAL CHIP	22K 0.50% 1/10W
R312	1-216-089-91	RES,CHIP	47K 5% 1/10W	R376	1-216-663-11	METAL CHIP	3.3K 0.50% 1/10W
R313	1-216-033-00	RES,CHIP	220 5% 1/10W	R378	1-216-025-91	RES,CHIP	100 5% 1/10W
R314	1-216-089-91	RES,CHIP	47K 5% 1/10W	R379	1-216-641-11	METAL CHIP	390 0.50% 1/10W
R315	1-216-113-00	RES,CHIP	470K 5% 1/10W	R380	1-216-668-11	METAL CHIP	5.1K 0.50% 1/10W
R316	1-216-105-91	RES,CHIP	220K 5% 1/10W	R381	1-216-089-91	RES,CHIP	47K 5% 1/10W
R317	1-216-109-00	RES,CHIP	330K 5% 1/10W	R382	1-216-025-91	RES,CHIP	100 5% 1/10W
R318	1-216-105-91	RES,CHIP	220K 5% 1/10W	R383	1-216-641-11	METAL CHIP	390 0.50% 1/10W
R319	1-216-099-00	RES,CHIP	120K 5% 1/10W	R384	1-216-668-11	METAL CHIP	5.1K 0.50% 1/10W
R320	1-216-099-00	RES,CHIP	120K 5% 1/10W	R385	1-216-117-00	RES,CHIP	680K 5% 1/10W
R321	1-216-043-91	RES,CHIP	560 5% 1/10W	R386	1-216-025-91	RES,CHIP	100 5% 1/10W
R322	1-216-109-00	RES,CHIP	330K 5% 1/10W	R387	1-216-641-11	METAL CHIP	390 0.50% 1/10W
R323	1-216-109-00	RES,CHIP	330K 5% 1/10W	R388	1-216-668-11	METAL CHIP	5.1K 0.50% 1/10W
R324	1-216-109-00	RES,CHIP	330K 5% 1/10W	R389	1-216-089-91	RES,CHIP	47K 5% 1/10W
R325	1-216-097-91	RES,CHIP	100K 5% 1/10W			(PVM-8042Q, 8045Q, 9042QM, 9045QM)	
R326	1-216-113-00	RES,CHIP	470K 5% 1/10W	R390	1-216-105-91	RES,CHIP	220K 5% 1/10W
R328	1-216-073-00	RES,CHIP	10K 5% 1/10W	R391	1-216-081-00	RES,CHIP	22K 5% 1/10W
R329	1-216-107-00	RES,CHIP	270K 5% 1/10W	R392	1-216-113-00	RES,CHIP	470K 5% 1/10W
R330	1-216-105-91	RES,CHIP	220K 5% 1/10W	R393	1-216-085-00	RES,CHIP	33K 5% 1/10W
R331	1-216-025-91	RES,CHIP	100 5% 1/10W	R394	1-216-113-00	RES,CHIP	470K 5% 1/10W
R332	1-216-097-91	RES,CHIP	100K 5% 1/10W	R397	1-249-437-11	CARBON	47K 5% 1/4W F
R333	1-216-097-91	RES,CHIP	100K 5% 1/10W	R398	1-249-434-11	CARBON	27K 5% 1/4W F
R334	1-216-025-91	RES,CHIP	100 5% 1/10W	R399	1-216-073-00	RES,CHIP	10K 5% 1/10W
R335	1-216-099-00	RES,CHIP	120K 5% 1/10W	R1001	1-216-073-00	RES,CHIP	10K 5% 1/10W
R336	1-216-095-00	RES,CHIP	82K 5% 1/10W	R1002	1-216-047-91	RES,CHIP	820 5% 1/10W
R337	1-216-105-91	RES,CHIP	220K 5% 1/10W	R1003	1-216-055-00	RES,CHIP	1.8K 5% 1/10W
R338	1-216-025-91	RES,CHIP	100 5% 1/10W	R1004	1-216-061-00	RES,CHIP	3.3K 5% 1/10W
R339	1-216-099-00	RES,CHIP	120K 5% 1/10W	R1005	1-216-047-91	RES,CHIP	820 5% 1/10W
R340	1-216-095-00	RES,CHIP	82K 5% 1/10W	R1006	1-216-055-00	RES,CHIP	1.8K 5% 1/10W
R341	1-216-105-91	RES,CHIP	220K 5% 1/10W	R1007	1-216-061-00	RES,CHIP	3.3K 5% 1/10W
R342	1-216-047-91	RES,CHIP	820 5% 1/10W	R1008	1-216-047-91	RES,CHIP	820 5% 1/10W
R343	1-216-053-00	RES,CHIP	1.5K 5% 1/10W	R1009	1-216-053-00	RES,CHIP	1.5K 5% 1/10W
R344	1-216-664-11	METAL CHIP	3.6K 0.50% 1/10W	R1010	1-216-061-00	RES,CHIP	3.3K 5% 1/10W
R345	1-216-661-11	METAL CHIP	2.7K 0.50% 1/10W	R1011	1-216-033-00	RES,CHIP	220 5% 1/10W
R346	1-216-105-91	RES,CHIP	220K 5% 1/10W	R1012	1-216-051-00	RES,CHIP	1.2K 5% 1/10W
R348	1-216-061-00	RES,CHIP	3.3K 5% 1/10W	R1013	1-216-051-00	RES,CHIP	1.2K 5% 1/10W
R349	1-216-650-11	METAL CHIP	910 0.50% 1/10W	R1014	1-216-246-00	RES,CHIP	100K 5% 1/8W
R350	1-216-653-11	METAL CHIP	1.2K 0.50% 1/10W	R1015	1-216-033-00	RES,CHIP	220 5% 1/10W
R351	1-216-650-11	METAL CHIP	910 0.50% 1/10W				



Ref.No.	Part No.	Description	Remark	Ref.No.	Part No.	Description	Remark
R1016	1-216-097-91	RES,CHIP	100K 5% 1/10W	R1077	1-216-103-00	RES,CHIP	180K 5% 1/10W
R1017	1-216-045-00	RES,CHIP	680 5% 1/10W	R1079	1-216-131-11	RES,CHIP	2.7M 5% 1/10W
R1018	1-216-043-91	RES,CHIP	560 5% 1/10W	R1080	1-216-097-91	RES,CHIP	100K 5% 1/10W
R1019	1-216-033-00	RES,CHIP	220 5% 1/10W	R1081	1-216-097-91	RES,CHIP	100K 5% 1/10W
R1020	1-216-097-91	RES,CHIP	100K 5% 1/10W	R1082	1-216-105-91	RES,CHIP	220K 5% 1/10W
R1021	1-216-045-00	RES,CHIP	680 5% 1/10W	R1083	1-216-065-91	RES,CHIP	4.7K 5% 1/10W
R1022	1-216-025-91	RES,CHIP	100 5% 1/10W	R1084	1-216-063-91	RES,CHIP	3.9K 5% 1/10W
R1023	1-216-073-00	RES,CHIP	10K 5% 1/10W	R1086	1-216-073-00	RES,CHIP	10K 5% 1/10W
R1024	1-216-025-91	RES,CHIP	100 5% 1/10W	R1087	1-216-121-91	RES,CHIP	1M 5% 1/10W
R1025	1-216-033-00	RES,CHIP	220 5% 1/10W	R1088	1-216-047-91	RES,CHIP	820 5% 1/10W
R1026	1-216-061-00	RES,CHIP	3.3K 5% 1/10W	R1090	1-216-049-91	RES,CHIP	1K 5% 1/10W
R1027	1-216-101-00	RES,CHIP	150K 5% 1/10W	R1091	1-216-049-91	RES,CHIP	1K 5% 1/10W
R1028	1-216-033-00	RES,CHIP	220 5% 1/10W	R1092	1-216-049-91	RES,CHIP	1K 5% 1/10W
R1029	1-216-061-00	RES,CHIP	3.3K 5% 1/10W	R1093	1-216-121-91	RES,CHIP	1M 5% 1/10W
R1030	1-216-089-91	RES,CHIP	47K 5% 1/10W	R1094	1-216-075-00	RES,CHIP	12K 5% 1/10W
R1031	1-216-033-00	RES,CHIP	220 5% 1/10W	R1095	1-216-075-00	RES,CHIP	12K 5% 1/10W
R1032	1-216-061-00	RES,CHIP	3.3K 5% 1/10W	R1096	1-216-075-00	RES,CHIP	12K 5% 1/10W
R1033	1-216-081-00	RES,CHIP	22K 5% 1/10W	R1200	1-216-699-11	METAL CHIP	100K 0.50% 1/10W
R1035	1-216-073-00	RES,CHIP	10K 5% 1/10W	R1201	1-218-754-11	METAL CHIP	120K 0.50% 1/10W
R1036	1-216-089-91	RES,CHIP	47K 5% 1/10W	R1207	1-216-061-00	RES,CHIP	3.3K 5% 1/10W
R1038	1-216-081-00	RES,CHIP	22K 5% 1/10W	R1208	1-216-065-91	RES,CHIP	4.7K 5% 1/10W
R1040	1-216-025-91	RES,CHIP	100 5% 1/10W	R1220	1-216-055-00	RES,CHIP	1.8K 5% 1/10W
R1042	1-216-047-91	RES,CHIP	820 5% 1/10W	R1221	1-216-055-00	RES,CHIP	1.8K 5% 1/10W
R1043	1-216-057-00	RES,CHIP	2.2K 5% 1/10W	R1222	1-216-055-00	RES,CHIP	1.8K 5% 1/10W
R1044	1-216-061-00	RES,CHIP	3.3K 5% 1/10W	R1223	1-216-689-11	RES,CHIP	39K 5% 1/10W
R1045	1-216-125-00	RES,CHIP	1.5M 5% 1/10W	R1225	1-215-876-00	METAL OXIDE	15K 5% 1W F
R1046	1-216-689-11	METAL CHIP	39K 0.50% 1/10W	R1226	1-215-876-00	METAL OXIDE	15K 5% 1W F
R1047	1-216-065-91	RES,CHIP	4.7K 5% 1/10W	R1227	1-215-876-00	METAL OXIDE	15K 5% 1W F
R1048	1-216-049-91	RES,CHIP	1K 5% 1/10W	R1228	1-249-421-11	CARBON	2.2K 5% 1/4W F
R1049	1-216-085-00	RES,CHIP	33K 5% 1/10W	R1229	1-249-421-11	CARBON	2.2K 5% 1/4W F
R1050	1-216-059-00	RES,CHIP	2.7K 5% 1/10W	R1230	1-249-421-11	CARBON	2.2K 5% 1/4W F
R1051	1-216-105-91	RES,CHIP	220K 5% 1/10W	R1231	1-216-029-00	RES,CHIP	150 5% 1/10W
R1053	1-216-091-00	RES,CHIP	56K 5% 1/10W	R1232	1-216-029-00	RES,CHIP	150 5% 1/10W
R1054	1-216-093-00	RES,CHIP	68K 5% 1/10W	R1233	1-216-029-00	RES,CHIP	150 5% 1/10W
R1055	1-216-097-91	RES,CHIP	100K 5% 1/10W	R1234	1-216-029-00	RES,CHIP	150 5% 1/10W
R1056	1-216-037-00	RES,CHIP	330 5% 1/10W	R1235	1-216-029-00	RES,CHIP	150 5% 1/10W
R1057	1-216-065-91	RES,CHIP	4.7K 5% 1/10W	R1236	1-216-029-00	RES,CHIP	150 5% 1/10W
R1058	1-216-109-00	RES,CHIP	330K 5% 1/10W	R1237	1-249-419-11	CARBON	1.5K 5% 1/4W F
R1059	1-216-109-00	RES,CHIP	330K 5% 1/10W	R1238	1-249-419-11	CARBON	1.5K 5% 1/4W F
R1060	1-216-109-00	RES,CHIP	330K 5% 1/10W	R1239	1-249-419-11	CARBON	1.5K 5% 1/4W F
R1061	1-216-109-00	RES,CHIP	330K 5% 1/10W	R1270	1-216-079-00	RES,CHIP	18K 5% 1/10W
R1062	1-216-103-00	RES,CHIP	180K 5% 1/10W	R1271	1-216-057-00	RES,CHIP	2.2K 5% 1/10W
R1063	1-216-103-00	RES,CHIP	180K 5% 1/10W	R1280	1-216-109-00	RES,CHIP	330K 5% 1/10W
R1064	1-216-103-00	RES,CHIP	180K 5% 1/10W	R1285	1-216-057-00	RES,CHIP	2.2K 5% 1/10W
R1065	1-216-103-00	RES,CHIP	180K 5% 1/10W	R1288	1-216-105-91	RES,CHIP	220K 5% 1/10W
R1066	1-216-073-00	RES,CHIP	10K 5% 1/10W	R1290	1-216-071-00	RES,CHIP	8.2K 5% 1/10W
R1067	1-216-073-00	RES,CHIP	10K 5% 1/10W	R1291	1-216-081-00	RES,CHIP	22K 5% 1/10W
R1068	1-216-049-91	RES,CHIP	1K 5% 1/10W	R1294	1-216-069-00	RES,CHIP	6.8K 5% 1/10W
R1069	1-216-133-00	RES,CHIP	3.3M 5% 1/10W	R1295	1-216-109-00	RES,CHIP	330K 5% 1/10W
R1070	1-216-085-00	RES,CHIP	33K 5% 1/10W	R1296	1-216-095-00	RES,CHIP	82K 5% 1/10W
R1071	1-216-113-00	RES,CHIP	470K 5% 1/10W	R1297	1-216-071-00	RES,CHIP	8.2K 5% 1/10W
R1072	1-216-099-00	RES,CHIP	120K 5% 1/10W	R1298	1-216-071-00	RES,CHIP	8.2K 5% 1/10W
R1073	1-216-131-11	RES,CHIP	2.7M 5% 1/10W	R1299	1-216-071-00	RES,CHIP	8.2K 5% 1/10W
R1075	1-216-065-91	RES,CHIP	4.7K 5% 1/10W	R1300	1-216-089-91	RES,CHIP	47K 5% 1/10W
R1076	1-216-101-00	RES,CHIP	150K 5% 1/10W	R1301	1-216-065-91	RES,CHIP	4.7K 5% 1/10W
				R1302	1-216-113-00	RES,CHIP	470K 5% 1/10W
				R1303	1-216-113-00	RES,CHIP	470K 5% 1/10W

Ref.No.	Part No.	Description	Remark	Ref.No.	Part No.	Description	Remark
R1304	1-216-091-00	RES,CHIP	56K 5% 1/10W	R1394	1-216-057-00	RES,CHIP	2.2K 5% 1/10W
R1305	1-216-093-00	RES,CHIP	68K 5% 1/10W	R1395	1-216-057-00	RES,CHIP	2.2K 5% 1/10W
R1306	1-216-063-91	RES,CHIP	3.9K 5% 1/10W	R1396	1-216-097-91	RES,CHIP	100K 5% 1/10W
R1307	1-216-041-00	RES,CHIP	470 5% 1/10W	R1397	1-216-097-91	RES,CHIP	100K 5% 1/10W
R1308	1-216-041-00	RES,CHIP	470 5% 1/10W	R1401	1-216-111-00	RES,CHIP	390K 5% 1/10W
R1309	1-216-063-91	RES,CHIP	3.9K 5% 1/10W	R1402	1-216-689-11	RES,CHIP	39K 5% 1/10W
R1310	1-216-119-00	RES,CHIP	820K 5% 1/10W	R1403	1-216-083-00	RES,CHIP	27K 5% 1/10W
R1313	1-216-101-00	RES,CHIP	150K 5% 1/10W (PVM-8042Q, 8045QM, 9042QM, 9045QM)	R1404	1-216-689-11	RES,CHIP	39K 5% 1/10W
R1313	1-216-099-00	RES,CHIP	120K 5% 1/10W (PVM-9045PM)	R1405	1-216-067-00	RES,CHIP	5.6K 5% 1/10W (PVM-8042Q, 9045QM, 9042QM, 9045QM)
R1314	1-216-053-00	RES,CHIP	1.5K 5% 1/10W	R1405	1-216-073-00	RES,CHIP	5.6K 5% 1/10W (PVM-9045PM)
R1315	1-216-077-00	RES,CHIP	15K 5% 1/10W	R1406	1-216-067-00	RES,CHIP	5.6K 5% 1/10W (PVM-8042Q, 9045QM, 9042QM, 9045QM)
R1320	1-216-083-00	RES,CHIP	27K 5% 1/10W	R1406	1-216-073-00	RES,CHIP	5.6K 5% 1/10W (PVM-9045PM)
R1321	1-216-093-00	RES,CHIP	68K 5% 1/10W	R1407	1-216-029-00	RES,CHIP	150 5% 1/10W
R1322	1-216-037-00	RES,CHIP	330 5% 1/10W	R1408	1-216-067-00	RES,CHIP	5.6K 5% 1/10W (PVM-8042Q, 9045QM, 9042QM, 9045QM)
R1323	1-216-057-00	RES,CHIP	2.2K 5% 1/10W	R1408	1-216-049-91	RES,CHIP	1K 5% 1/10W (PVM-9045PM)
R1324	1-216-121-91	RES,CHIP	1M 5% 1/10W	R1409	1-216-067-00	RES,CHIP	5.6K 5% 1/10W (PVM-8042Q, 9045QM, 9042QM, 9045QM)
R1325	1-216-085-00	RES,CHIP	33K 5% 1/10W	R1409	1-216-049-91	RES,CHIP	1K 5% 1/10W
R1326	1-216-065-91	RES,CHIP	4.7K 5% 1/10W	R1410	1-216-097-91	RES,CHIP	100K 5% 1/10W
R1327	1-216-099-00	RES,CHIP	120K 5% 1/10W	R1411	1-216-089-91	RES,CHIP	47K 5% 1/10W
R1328	1-216-099-00	RES,CHIP	120K 5% 1/10W	R1412	1-216-097-91	RES,CHIP	100K 5% 1/10W
R1329	1-216-093-00	RES,CHIP	68K 5% 1/10W	R1413	1-216-073-00	RES,CHIP	10K 5% 1/10W
R1330	1-216-063-91	RES,CHIP	3.9K 5% 1/10W	R1414	1-216-111-00	RES,CHIP	390K 5% 1/10W
R1331	1-216-051-00	RES,CHIP	1.2K 5% 1/10W			<VARIABLE RESISTOR>	
R1332	1-216-057-00	RES,CHIP	2.2K 5% 1/10W	RV101	1-241-763-11	RES, ADJ, CERMET 4.7K (PVM-8042Q, 8045Q, 9042QM, 9045QM)	
R1333	1-216-057-00	RES,CHIP	2.2K 5% 1/10W	RV102	1-241-763-11	RES, ADJ, CERMET 4.7K	
R1334	1-216-055-00	RES,CHIP	1.8K 5% 1/10W	RV103	1-241-759-11	RES, ADJ, CARBON 220 (PVM-8042Q, 8045Q, 9042QM, 9045QM)	
R1335	1-216-035-00	RES,CHIP	270 5% 1/10W	RV104	1-241-759-11	RES, ADJ, CARBON 220	
R1336	1-216-089-91	RES,CHIP	47K 5% 1/10W	RV105	1-241-761-11	RES, ADJ, CARBON 1K	
R1337	1-216-113-00	RES,CHIP	470K 5% 1/10W	RV106	1-241-761-11	RES, ADJ, CARBON 1K (PVM-8042Q, 8045Q, 9042QM, 9045QM)	
R1338	1-216-049-91	RES,CHIP	1K 5% 1/10W	RV107	1-241-761-11	RES, ADJ, CARBON 1K	
R1339	1-216-097-91	RES,CHIP	100K 5% 1/10W (PVM-8042Q, 8045Q, 9042QM, 9045QM)	RV108	1-241-764-11	RES, ADJ, CARBON 10K (PVM-8042Q, 8045Q, 9042QM, 9045QM)	
R1340	1-216-097-91	RES,CHIP	100K 5% 1/10W (PVM-8042Q, 8045Q, 9042QM, 9045QM)	RV109	1-241-765-11	RES, ADJ, CERMET 22K	
R1341	1-216-111-00	RES,CHIP	390K 5% 1/10W (PVM-8042Q, 8045Q, 9042QM, 9045QM)	RV110	1-241-764-11	RES, ADJ, CARBON 10K	
R1342	1-216-694-11	METAL CHIP	62K 0.50% 1/10W (PVM-8042Q, 8045Q, 9042QM, 9045QM)	RV111	1-241-764-11	RES, ADJ, CARBON 10K	
R1343	1-216-121-91	RES,CHIP	1M 5% 1/10W (PVM-8042Q, 8045Q, 9042QM, 9045QM)	RV112	1-238-019-11	RES, ADJ, CARBON 47K (PVM-8042Q, 8045Q, 9042QM, 9045QM)	
R1344	1-216-073-00	RES,CHIP	10K 5% 1/10W (PVM-8042Q, 8045Q, 9042QM, 9045QM)	RV113	1-238-019-11	RES, ADJ, CARBON 47K	
R1345	1-216-055-00	RES,CHIP	1.8K 5% 1/10W (PVM-8042Q, 8045Q, 9042QM, 9045QM)	RV114	1-238-019-11	RES, ADJ, CARBON 47K	
R1346	1-216-047-91	RES,CHIP	820 5% 1/10W (PVM-8042Q, 8045Q, 9042QM, 9045QM)	RV115	1-241-765-11	RES, ADJ, CARBON 22K	
R1347	1-216-073-00	RES,CHIP	10K 5% 1/10W	RV116	1-241-765-11	RES, ADJ, CARBON 22K	
R1348	1-216-073-00	RES,CHIP	10K 5% 1/10W	RV118	1-241-765-11	RES, ADJ, CARBON 22K	
R1349	1-216-073-00	RES,CHIP	10K 5% 1/10W	RV119	1-241-765-11	RES, ADJ, CARBON 22K	
R1350	1-216-073-00	RES,CHIP	10K 5% 1/10W	RV120	1-241-765-11	RES, ADJ, CARBON 22K	
R1351	1-216-073-00	RES,CHIP	10K 5% 1/10W	RV121	1-241-765-11	RES, ADJ, CARBON 22K	
R1352	1-216-073-00	RES,CHIP	10K 5% 1/10W	RV122	1-241-765-11	RES, ADJ, CARBON 22K	
R1353	1-216-115-00	RES,CHIP	560K 5% 1/10W	RV123	1-241-762-11	RES, ADJ, CARBON 2.2K	
R1371	1-216-057-00	RES,CHIP	2.2K 5% 1/10W	RV124	1-241-761-11	RES, ADJ, CARBON 1K	
R1372	1-216-057-00	RES,CHIP	2.2K 5% 1/10W	RV125	1-241-761-11	RES, ADJ, CARBON 1K	
R1373	1-216-057-00	RES,CHIP	2.2K 5% 1/10W				
R1392	1-216-089-91	RES,CHIP	47K 5% 1/10W				
R1393	1-216-095-00	RES,CHIP	82K 5% 1/10W				

Ref.No.	Part No.	Description	Remark	Ref.No.	Part No.	Description	Remark
RV205	1-241-765-11	RES, ADJ, CARBON 22K		*****			
RV1400	1-237-036-11	RES, ADJ, CERMET 10K			* A-1195-146-A	P BOARD, COMPETE	
RV1401	1-237-036-11	RES, ADJ, CERMET 10K				*****	
		<MODULE>			* 4-043-154-01	HOLDER, IC	
					4-382-854-01	SCREW (M3X8), P, SW (+)	
					4-879-937-00	SHEET, MICA	
SEP101	1-808-654-11	MODULE (PVM-8042Q, 8045Q, 9042QM, 9045QM)				<CAPACITOR>	
SEP101	1-809-347-11	MODULE (PVM-9045PM)					
		<CRYSTAL>		C801	1-126-971-11	ELECT 470µF 20%	35V
				C802	1-102-228-00	CERAMIC 470PF 10%	500V
				C803	1-102-228-00	CERAMIC 470PF 10%	500V
X1400	1-527-722-00	VIBRATOR, CRYSTAL		C804	1-107-638-11	ELECT 33µF 20%	160V
X1401	1-527-523-00	OSCILLATOR CRYSTAL (PVM-9045PM)		C806	1-124-480-11	ELECT 470µF 20%	25V
X1401	1-577-259-11	VIBRATOR, CRYSTAL (PVM-8042Q, 8045Q, 9042QM, 9045QM)		C807	1-102-228-00	CERAMIC 470PF 10%	500V
				C808	1-137-150-11	MYLAR 0.01µF 10%	100V
				C809	1-106-375-12	MYLAR 0.022µF 10%	100V
				C810	1-162-318-11	CERAMIC 0.001µF 10%	500V
				C811	△ 1-137-544-11	FILM 0.01µF 3%	600V
				C812	△ 1-137-545-11	FILM 0.013µF 3%	600V
				C813	1-107-385-11	MYLAR 0.056µF 5%	200V
				C814	1-137-353-11	MYLAR 0.047µF 10%	100V
				C815	1-124-910-11	ELECT 47µF 20%	50V
				C816	1-107-675-11	ELECT 1µF 20%	160V
				C818	1-102-228-00	CERAMIC 470PF 10%	500V
				C819	1-162-116-00	CERAMIC 680PF 10%	2KV
				C820	1-162-116-00	CERAMIC 680PF 10%	2KV
				C821	1-162-116-00	CERAMIC 680PF 10%	2KV
				C825	1-123-024-21	ELECT 33µF	160V
				C880	1-163-031-11	CERAMIC CHIP 0.01µF	50V
				C883	1-129-720-00	FILM 0.033µF 5%	630V
						<CONNECTOR>	
				CN801	* 1-564-595-11	PLUG, CONNECTOR 14P	
				CN802	* 1-508-766-00	PIN, CONNECTOR (5MM PITCH) 4P	
				CN803	* 1-564-508-11	PLUG, CONNECTOR 5P	
				CN810	1-695-915-11	TAB (CONTACT)	
				CN811	* 1-564-506-11	PLUG, CONNECTOR 3P	
						<DIODE>	
D815	8-719-911-19	DIODE 1SS119-25		D801	8-719-302-43	DIODE EL1Z	
				D802	8-719-302-43	DIODE EL1Z	
				D803	8-719-302-43	DIODE EL1Z	
				D804	8-719-979-85	DIODE EGP20G	
				D805	8-719-302-43	DIODE EL1Z	
				D806	8-719-302-43	DIODE EL1Z	
				D808	8-719-018-72	THYRISTOR CR02AM-4TB	
				D809	8-719-908-03	DIODE GP08D	
				D810	8-719-908-03	DIODE GP08D	
				D811	8-719-908-03	DIODE GP08D	
				D813	8-719-302-43	DIODE EL1Z	
				D814	8-719-901-19	DIODE V11N	
						<COIL>	
				L802	1-459-442-00	INDUCTOR 15µH	

Ref.No.	Part No.	Description	Remark	Ref.No.	Part No.	Description	Remark
L803	1-422-613-11	COIL, AIR CORE 0.68μH				<FUSE>	
L805	△ 1-460-225-11	COIL, HORIZONTAL LINEARITY 48.80		F601	△ 1-532-745-11	FUSE, GLASS TUBE 3.15A/125V (PVM-8042Q, 8045Q, 9045PM)	
L807	1-406-987-21	INDUCTOR 4.7mH		F601	△ 1-576-230-11	FUSE (H.B.C) 3.15A/250V (PVM-9042QM, PVM-9045QM)	
L810	1-412-529-11	INDUCTOR 22μH				<RESISTOR>	
		<NEON LAMP>		R602	△ 1-202-887-91	SOLID 1.5M 20% 1/2W	
NL801	1-519-108-99	LAMP, NEON				<SWITCH>	
		<TRANSISTOR>		S601	△ 1-692-049-11	SWITCH, PUSH (AC POWER) (1KEY) (3.0A/250V) (PVM-8042Q, 8045Q, 9045PM)	
Q801	8-729-195-82	TRANSISTOR 2SC2958-L		S601	△ 1-692-050-11	SWITCH, PUSH (AC POWER) (1KEY) (PVM-9042QM, 9045QM)	
Q802	8-729-201-62	TRANSISTOR 2SC2555-2				<RESISTOR>	
		<RESISTOR>		R801	1-249-383-11	CARBON 1.5 5% 1/4W F	
R801	1-249-383-11	CARBON 1.5 5% 1/4W F		R802	1-249-377-11	CARBON 0.47 5% 1/4W F	
R802	1-249-377-11	CARBON 0.47 5% 1/4W F		R803	1-216-049-91	RES,CHIP 1K 5% 1/10W	
R803	1-216-049-91	RES,CHIP 1K 5% 1/10W		R804	1-249-419-11	CARBON 1.5K 5% 1/4W F	
R804	1-249-419-11	CARBON 1.5K 5% 1/4W F		R805	1-215-892-11	METAL OXIDE 1K 5% 2W F	
R805	1-215-892-11	METAL OXIDE 1K 5% 2W F				*****	
R807	1-216-425-11	METAL OXIDE 56 5% 1W F				* A-1275-162-A QA COMPLETE	
R808	1-202-846-00	SOLID 470K 20% 1/2W				*****	
R809	1-216-089-91	RES,CHIP 47K 5% 1/10W				1-537-408-21	TERMINAL BOARD, INPUT/OUTPUT
R810	1-249-421-11	CARBON 2.2K 5% 1/4W F				1-537-410-11	TERMINAL BOARD, INPUT/OUTPUT
R811	1-216-049-91	RES,CHIP 1K 5% 1/10W				<CAPACITOR>	
R813	1-249-414-11	CARBON 560 5% 1/4W F		C401	1-126-514-11	ELECT 22μF 20% 16V	
R814	1-249-377-11	CARBON 0.47 5% 1/4W F		C402	1-126-514-11	ELECT 22μF 20% 16V	
R817	1-216-065-91	RES,CHIP 4.7K 5% 1/10W		C403	1-126-514-11	ELECT 22μF 20% 16V	
		<VARIABLE RESISTOR>		C404	1-126-514-11	ELECT 22μF 20% 16V	
RV801	1-223-102-00	RES, ADJ, WIREWOUND 120		C405	1-126-514-11	ELECT 22μF 20% 16V	
		<TRANSFORMER>		C406	1-126-514-11	ELECT 22μF 20% 16V	
T801	1-437-082-31	HDT		C407	1-126-514-11	ELECT 22μF 20% 16V	
T802	△ 1-439-526-12	TRANSFORMER ASSY, FLYBACK		C408	1-115-867-11	ELECT 0.1μF 20% 50V	
				C409	1-126-514-11	ELECT 22μF 20% 16V	
				C410	1-126-514-11	ELECT 22μF 20% 16V	
				C411	1-126-514-11	ELECT 22μF 20% 16V	
				C412	1-126-514-11	ELECT 22μF 20% 16V	
				C413	1-126-514-11	ELECT 22μF 20% 16V	
				C414	1-126-791-11	ELECT 10μF 20% 16V	
				C415	1-126-791-11	ELECT 10μF 20% 16V	
				C416	1-126-791-11	ELECT 10μF 20% 16V	
				C417	1-126-791-11	ELECT 10μF 20% 16V	
				C418	1-126-791-11	ELECT 10μF 20% 16V	
				C419	1-126-791-11	ELECT 10μF 20% 16V	
				C420	1-126-791-11	ELECT 10μF 20% 16V	
				C421	1-102-125-00	CERAMIC 0.0047μF 10% 50V	
				C422	1-115-868-11	ELECT 0.22μF 20% 50V	
				C423	1-126-791-11	ELECT 10μF 20% 16V	
				C424	1-126-791-11	ELECT 10μF 20% 16V	
				C425	1-137-397-11	FILM 0.047μF 5% 100V	
				C426	1-128-499-11	ELECT 220μF 20% 16V	
				C427	1-128-499-11	ELECT 220μF 20% 16V	
				C428	1-107-909-11	ELECT 47μF 20% 16V	
				C429	1-126-514-11	ELECT 22μF 20% 16V	
				C430	1-163-033-91	CERAMIC CHIP 0.022μF 50V	
C601	△ 1-136-889-11	FILM 0.22μF 20% 250V				<CONNECTOR>	
		<CONNECTOR>		CN601	* 1-580-689-11	PIN, CONNECTOR (PC BOARD) 4P	
CN601	* 1-580-689-11	PIN, CONNECTOR (PC BOARD) 4P		CN602	* 1-508-765-00	PIN, CONNECTOR (5MM PITCH) 3P	
CN602	* 1-508-765-00	PIN, CONNECTOR (5MM PITCH) 3P		CN603	* 1-564-507-11	PLUG, CONNECTOR 4P	
CN603	* 1-564-507-11	PLUG, CONNECTOR 4P					



Ref.No.	Part No.	Description	Remark	Ref.No.	Part No.	Description	Remark
C431	1-126-514-11	ELECT 22μF	20% 16V	D417	8-719-404-49	DIODE MA111	
C432	1-163-033-91	CERAMIC CHIP 0.022μF	50V	D418	8-719-404-49	DIODE MA111	
C433	1-126-514-11	ELECT 22μF	20% 16V	D419	8-719-404-49	DIODE MA111	
C434	1-163-033-91	CERAMIC CHIP 0.022μF	50V	D420	8-719-404-49	DIODE MA111	
C435	1-126-514-11	ELECT 22μF	20% 16V	D421	8-719-404-49	DIODE MA111	
C436	1-163-033-91	CERAMIC CHIP 0.022μF	50V	D422	8-719-404-49	DIODE MA111	
C437	1-163-033-91	CERAMIC CHIP 0.022μF	50V	D423	8-719-404-49	DIODE MA111	
C438	1-126-514-11	ELECT 22μF	20% 16V	D424	8-719-404-49	DIODE MA111	
C439	1-163-033-91	CERAMIC CHIP 0.022μF	50V	D425	8-719-404-49	DIODE MA111	
C440	1-163-033-91	CERAMIC CHIP 0.022μF	50V	D426	8-719-404-49	DIODE MA111	
C441	1-126-514-11	ELECT 22μF	20% 16V	D427	8-719-404-49	DIODE MA111	
C442	1-163-033-91	CERAMIC CHIP 0.022μF	50V	D428	8-719-404-49	DIODE MA111	
C443	1-163-033-91	CERAMIC CHIP 0.022μF	50V	D429	8-719-404-49	DIODE MA111	
C444	1-163-033-91	CERAMIC CHIP 0.022μF	50V	D430	8-719-404-49	DIODE MA111	
C445	1-163-031-11	CERAMIC CHIP 0.01μF	50V	D431	8-719-404-49	DIODE MA111	
C446	1-163-031-11	CERAMIC CHIP 0.01μF	50V				
C447	1-115-871-11	ELECT 1μF	20% 50V			<IC>	
C448	1-126-514-11	ELECT 22μF	20% 16V	IC401	8-759-446-66	IC MM1113XFBE	
C449	1-163-031-11	CERAMIC CHIP 0.01μF	50V	IC402	8-759-446-66	IC MM1113XFBE	
C450	1-126-514-11	ELECT 22μF	20% 16V	IC403	8-759-420-04	IC AN5265	
C451	1-163-033-91	CERAMIC CHIP 0.022μF	50V			<COIL>	
C452	1-128-126-11	ELECT 100μF	20% 25V	L401	1-410-682-31	INDUCTOR 470μH	
C453	1-126-514-11	ELECT 22μF	20% 16V	L402	1-410-682-31	INDUCTOR 470μH	
C454	1-128-499-11	ELECT 220μF	20% 16V			<TRANSISTOR>	
C460	1-115-871-11	ELECT 1μF	20% 50V	Q401	8-729-120-28	TRANSISTOR 2SC1623-L5L6	
C461	1-115-871-11	ELECT 1μF	20% 50V	Q402	8-729-120-28	TRANSISTOR 2SC1623-L5L6	
C462	1-115-871-11	ELECT 1μF	20% 50V	Q403	8-729-216-22	TRANSISTOR 2SA1162-G	
C464	1-163-031-11	CERAMIC CHIP 0.01μF	50V	Q404	8-729-120-28	TRANSISTOR 2SC1623-L5L6	
C465	1-163-031-11	CERAMIC CHIP 0.01μF	50V	Q405	8-729-120-28	TRANSISTOR 2SC1623-L5L6	
C466	1-163-031-11	CERAMIC CHIP 0.01μF	50V	Q406	8-729-120-28	TRANSISTOR 2SC1623-L5L6	
C467	1-163-031-11	CERAMIC CHIP 0.01μF	50V	Q407	8-729-120-28	TRANSISTOR 2SC1623-L5L6	
C475	1-163-031-11	CERAMIC CHIP 0.01μF	50V	Q408	8-729-120-28	TRANSISTOR 2SC1623-L5L6	
C1401	1-128-126-11	ELECT 100μF	20% 25V	Q409	8-729-120-28	TRANSISTOR 2SC1623-L5L6	
		<CONNECTOR>		Q410	8-729-120-28	TRANSISTOR 2SC1623-L5L6	
CN401	1-506-494-11	PIN, CONNECTOR 15P		Q411	8-729-216-22	TRANSISTOR 2SA1162-G	
CN402	* 1-564-518-11	PLUG, CONNECTOR 3P		Q412	8-729-216-22	TRANSISTOR 2SA1162-G	
CN403	* 1-580-690-11	PIN, CONNECTOR (PC BOARD) 2P		Q413	8-729-216-22	TRANSISTOR 2SA1162-G	
CN404	* 1-564-520-11	PLUG, CONNECTOR 5P		Q414	8-729-216-22	TRANSISTOR 2SA1162-G	
		<DIODE>		Q416	8-729-106-68	TRANSISTOR 2SD1615A-GP	
D401	8-719-404-49	DIODE MA111		Q417	8-729-901-06	TRANSISTOR DTA144EK	
D402	8-719-404-49	DIODE MA111		Q418	8-729-901-06	TRANSISTOR DTA144EK	
D403	8-719-110-09	DIODE RD8.2ESB3		Q419	8-729-901-06	TRANSISTOR DTA144EK	
D404	8-719-404-49	DIODE MA111		Q421	8-729-901-06	TRANSISTOR DTA144EK	
D405	8-719-404-49	DIODE MA111		Q422	1-801-806-11	TRANSISTOR DTC144EK-T147	
D406	8-719-404-49	DIODE MA111		Q423	8-729-901-06	TRANSISTOR DTA144EK	
D407	8-719-404-49	DIODE MA111		Q424	8-729-901-06	TRANSISTOR DTA144EK	
D408	8-719-404-49	DIODE MA111		Q1401	8-729-120-28	TRANSISTOR 2SC1623-L5L6	
D409	8-719-404-49	DIODE MA111		Q1403	8-729-120-28	TRANSISTOR 2SC1623-L5L6	
D410	8-719-404-49	DIODE MA111		Q1404	8-729-216-22	TRANSISTOR 2SA1162-G	
D411	8-719-404-49	DIODE MA111		Q1405	8-729-216-22	TRANSISTOR 2SA1162-G	
D412	8-719-404-49	DIODE MA111		Q1406	8-729-216-22	TRANSISTOR 2SA1162-G	
D413	8-719-404-49	DIODE MA111		Q1407	8-729-120-28	TRANSISTOR 2SC1623-L5L6	
D414	8-719-404-49	DIODE MA111					
D415	8-719-404-49	DIODE MA111					
D416	8-719-404-49	DIODE MA111					

Ref.No.	Part No.	Description	Remark	Ref.No.	Part No.	Description	Remark
	<RESISTOR>			R458	1-247-707-11	CARBON	390 5% 1/4W
R401	1-214-702-00	METAL	75 1% 1/4W	R459	1-216-689-11	RES,CHIP	39K 5% 1/10W
R402	1-216-049-91	RES,CHIP	1K 5% 1/10W	R460	1-216-089-91	RES,CHIP	47K 5% 1/10W
R403	1-216-093-00	RES,CHIP	68K 5% 1/10W	R461	1-216-097-91	RES,CHIP	100K 5% 1/10W
R404	1-216-091-00	RES,CHIP	56K 5% 1/10W	R462	1-216-115-00	RES,CHIP	560K 5% 1/10W
R405	1-216-063-91	RES,CHIP	3.9K 5% 1/10W	R463	1-216-105-91	RES,CHIP	220K 5% 1/10W
R406	1-216-037-00	RES,CHIP	330 5% 1/10W	R464	1-216-077-00	RES,CHIP	15K 5% 1/10W
R407	1-216-689-11	RES,CHIP	39K 5% 1/10W	R465	1-216-025-91	RES,CHIP	100 5% 1/10W
R408	1-216-085-00	RES,CHIP	33K 5% 1/10W	R466	1-216-097-91	RES,CHIP	100K 5% 1/10W
R409	1-214-702-00	METAL	75 1% 1/4W	R467	1-216-115-00	RES,CHIP	560K 5% 1/10W
R410	1-216-049-91	RES,CHIP	1K 5% 1/10W	R468	1-216-105-91	RES,CHIP	220K 5% 1/10W
R411	1-216-093-00	RES,CHIP	68K 5% 1/10W	R469	1-216-077-00	RES,CHIP	15K 5% 1/10W
R412	1-216-091-00	RES,CHIP	56K 5% 1/10W	R470	1-216-025-91	RES,CHIP	100 5% 1/10W
R413	1-216-063-91	RES,CHIP	3.9K 5% 1/10W	R471	1-216-097-91	RES,CHIP	100K 5% 1/10W
R414	1-216-037-00	RES,CHIP	330 5% 1/10W	R472	1-216-115-00	RES,CHIP	560K 5% 1/10W
R415	1-216-061-00	RES,CHIP	3.3K 5% 1/10W	R473	1-216-105-91	RES,CHIP	220K 5% 1/10W
R416	1-216-023-00	RES,CHIP	82 5% 1/10W	R474	1-216-077-00	RES,CHIP	15K 5% 1/10W
R417	1-216-049-91	RES,CHIP	1K 5% 1/10W	R475	1-216-025-91	RES,CHIP	100 5% 1/10W
R418	1-216-093-00	RES,CHIP	68K 5% 1/10W	R477	1-216-081-00	RES,CHIP	22K 5% 1/10W
R419	1-216-091-00	RES,CHIP	56K 5% 1/10W	R479	1-216-085-00	RES,CHIP	33K 5% 1/10W
R420	1-216-063-91	RES,CHIP	3.9K 5% 1/10W	R480	1-247-711-11	CARBON	680 5% 1/4W
R421	1-216-027-00	RES,CHIP	120 5% 1/10W	R481	1-247-720-11	CARBON	3.9K 5% 1/4W
R422	1-214-702-00	METAL	75 1% 1/4W	R482	1-249-455-11	CARBON	4.7 5% 1/4W
R423	1-214-702-00	METAL	75 1% 1/4W	R483	1-249-389-11	CARBON	4.7 5% 1/4W F
R424	1-216-049-91	RES,CHIP	1K 5% 1/10W	R484	1-216-049-91	RES,CHIP	1K 5% 1/10W
R425	1-216-093-00	RES,CHIP	68K 5% 1/10W	R485	1-247-688-11	CARBON	10 5% 1/4W F
R426	1-216-091-00	RES,CHIP	56K 5% 1/10W	R486	1-216-037-00	RES,CHIP	330 5% 1/10W
R427	1-216-063-91	RES,CHIP	3.9K 5% 1/10W	R487	1-249-468-11	CARBON	82K 5% 1/4W
R428	1-216-037-00	RES,CHIP	330 5% 1/10W	R488	1-249-468-11	CARBON	82K 5% 1/4W
R429	1-214-702-00	METAL	75 1% 1/4W	R489	1-249-468-11	CARBON	82K 5% 1/4W
R430	1-216-049-91	RES,CHIP	1K 5% 1/10W	R490	1-216-057-00	RES,CHIP	2.2K 5% 1/10W
R431	1-216-093-00	RES,CHIP	68K 5% 1/10W	R491	1-216-089-91	RES,CHIP	47K 5% 1/10W
R432	1-216-091-00	RES,CHIP	56K 5% 1/10W	R492	1-216-089-91	RES,CHIP	47K 5% 1/10W
R433	1-216-063-91	RES,CHIP	3.9K 5% 1/10W	R493	1-216-089-91	RES,CHIP	47K 5% 1/10W
R434	1-216-651-11	METAL CHIP	1K 0.50% 1/10W	R495	1-216-295-91	SHORT	0
R435	1-214-702-00	METAL	75 1% 1/4W	R496	1-216-057-00	RES,CHIP	2.2K 5% 1/10W
R436	1-216-049-91	RES,CHIP	1K 5% 1/10W	R497	1-216-089-91	RES,CHIP	47K 5% 1/10W
R437	1-216-093-00	RES,CHIP	68K 5% 1/10W	R498	1-216-089-91	RES,CHIP	47K 5% 1/10W
R438	1-216-091-00	RES,CHIP	56K 5% 1/10W	R499	1-216-089-91	RES,CHIP	47K 5% 1/10W
R439	1-216-063-91	RES,CHIP	3.9K 5% 1/10W	R1401	1-216-097-91	RES,CHIP	100K 5% 1/10W
R440	1-216-027-00	RES,CHIP	120 5% 1/10W	R1403	1-216-295-91	SHORT	0
R441	1-216-089-91	RES,CHIP	47K 5% 1/10W	R1404	1-216-097-91	RES,CHIP	100K 5% 1/10W
R442	1-216-049-91	RES,CHIP	1K 5% 1/10W	R1410	1-216-049-91	RES,CHIP	1K 5% 1/10W
R443	1-216-689-11	RES,CHIP	39K 5% 1/10W	R1411	1-216-089-91	RES,CHIP	47K 5% 1/10W
R444	1-214-702-00	METAL	75 1% 1/4W	R1412	1-216-113-00	RES,CHIP	470K 5% 1/10W
R445	1-216-049-91	RES,CHIP	1K 5% 1/10W	R1413	1-216-073-00	RES,CHIP	10K 5% 1/10W
R446	1-216-093-00	RES,CHIP	68K 5% 1/10W	R1414	1-216-662-11	METAL CHIP	3K 0.50% 1/10W
R447	1-216-091-00	RES,CHIP	56K 5% 1/10W	R1416	1-216-662-11	METAL CHIP	3K 0.50% 1/10W
R448	1-216-063-91	RES,CHIP	3.9K 5% 1/10W	R1417	1-216-063-91	RES,CHIP	3.9K 5% 1/10W
R449	1-216-651-11	METAL CHIP	1K 0.50% 1/10W	R1418	1-216-027-00	RES,CHIP	120 5% 1/10W
R450	1-214-702-00	METAL	75 1% 1/4W	R1419	1-216-063-91	RES,CHIP	3.9K 5% 1/10W
R451	1-216-049-91	RES,CHIP	1K 5% 1/10W	R1420	1-216-027-00	RES,CHIP	120 5% 1/10W
R452	1-216-091-00	RES,CHIP	56K 5% 1/10W	R1421	1-216-063-91	RES,CHIP	3.9K 5% 1/10W
R453	1-216-093-00	RES,CHIP	68K 5% 1/10W	R1422	1-216-027-00	RES,CHIP	120 5% 1/10W
R454	1-216-063-91	RES,CHIP	3.9K 5% 1/10W	R1423	1-216-073-00	RES,CHIP	10K 5% 1/10W
R455	1-216-037-00	RES,CHIP	330 5% 1/10W	R1424	1-216-049-91	RES,CHIP	1K 5% 1/10W
R456	1-216-085-00	RES,CHIP	33K 5% 1/10W	R1425	1-216-073-00	RES,CHIP	10K 5% 1/10W
R457	1-216-085-00	RES,CHIP	33K 5% 1/10W	R1426	1-216-049-91	RES,CHIP	1K 5% 1/10W





Ref.No.	Part No.	Description	Remark	Ref.No.	Part No.	Description	Remark
C563	1-137-353-11	MYLAR 0.047μF 10%	100V	CN600	* 1-564-001-11	PIN, CONNECTOR 2P	
C564	1-163-009-11	CERAMIC CHIP 0.001μF 10%	50V				
C567	1-107-906-11	ELECT 10μF 20%	50V				
C568	1-130-736-11	FILM 0.01μF 5%	50V			<DIODE>	
C569	1-136-479-11	FILM 0.001μF 5%	50V				
C570	1-163-117-00	CERAMIC CHIP 100PF 5%	50V	D501	8-719-404-49	DIODE MA111	
C571	1-126-971-11	ELECT 470μF 20%	50V	D502	8-719-404-49	DIODE MA111	
C572	1-101-004-00	CERAMIC 0.01μF	50V	D503	8-719-404-49	DIODE MA111	
C574	1-136-481-11	MYLAR 0.0022μF 10%	100V	D504	8-719-404-49	DIODE MA111	
C575	1-136-481-11	MYLAR 0.0022μF 10%	100V	D506	8-719-908-03	DIODE GP08D	
C578	1-163-031-11	CERAMIC CHIP 0.01μF	50V	D507	8-719-404-49	DIODE MA111	
C831	1-107-906-11	ELECT 10μF 20%	50V	D508	8-719-404-49	DIODE MA111	
C832	1-107-906-11	ELECT 10μF 20%	50V	D511	8-719-404-49	DIODE MA111	
C833	1-163-009-11	CERAMIC CHIP 0.001μF 10%	50V	D512	8-719-404-49	DIODE MA111	
C834	1-163-121-00	CERAMIC CHIP 150PF 5%	50V	D514	8-719-404-49	DIODE MA111	
C835	1-163-209-00	CERAMIC CHIP 0.0015μF 5%	50V	D520	8-719-800-76	DIODE 1SS226	
C836	1-126-964-11	ELECT 10μF 20%	50V	D521	8-719-800-76	DIODE 1SS226	
C837	1-163-209-00	CERAMIC CHIP 0.0015μF 5%	50V	D831	8-719-404-49	DIODE MA111	
C838	1-136-495-11	FILM 0.068μF 5%	50V	D832	8-719-404-49	DIODE MA111	
C839	1-136-481-11	MYLAR 0.0022μF 10%	100V	D833	8-719-404-49	DIODE MA111	
C840	1-163-209-00	CERAMIC CHIP 0.0015μF 5%	50V	D834	8-719-404-49	DIODE MA111	
C841	1-163-209-00	CERAMIC CHIP 0.0015μF 5%	50V	D835	8-719-109-89	DIODE RD5.6ESB2	
C843	1-107-901-11	ELECT 0.47μF 20%	50V	D836	8-719-977-69	DIODE DTZ24B	
C844	1-107-901-11	ELECT 0.47μF 20%	50V	D848	8-719-800-76	DIODE 1SS226	
C845	1-107-888-11	ELECT 47μF 20%	25V	D1601	8-719-105-99	DIODE RD6.2M-B1	
C846	1-107-906-11	ELECT 10μF 20%	50V	D1603	8-719-977-61	DIODE DTZ20B	
C847	1-126-965-11	ELECT 22μF 20%	50V	D1606	8-719-981-00	DIODE ERC81-004	
C848	1-131-351-00	TANTALUM 4.7μF 10%	35V	D1607	8-719-981-00	DIODE ERC81-004	
C849	1-164-182-11	CERAMIC CHIP 0.0033μF 10%	50V	D1608	8-719-978-24	DIODE DTZ-TT11-5.6A	
C1601	1-126-964-11	ELECT 10μF 20%	50V	D1609	8-719-977-49	DIODE DTZ15B	
C1602	1-164-161-11	CERAMIC CHIP 0.0022μF 10%	50V	D1610	8-719-404-49	DIODE MA111	
C1603	1-111-108-11	ELECT 18μF 20%	50V	D1612	8-719-404-49	DIODE MA111	
C1604	1-115-842-11	ELECT 0.001F 20%	50V	D1615	8-719-404-49	DIODE MA111	
C1605	1-126-972-11	ELECT 1000μF 20%	50V	D1617	8-719-977-49	DIODE DTZ15B	
C1606	1-163-009-11	CERAMIC CHIP 0.001μF 10%	50V	D1618	8-719-977-49	DIODE DTZ15B	
C1607	1-126-964-11	ELECT 10μF 20%	50V	D1620	8-719-801-78	DIODE 1SS184	
C1608	1-126-965-11	ELECT 22μF 20%	50V	D1621	8-719-510-12	DIODE D10SC4M	
C1609	1-163-009-11	CERAMIC CHIP 0.001μF 10%	50V	D1622	8-719-801-78	DIODE 1SS184	
C1610	1-126-963-11	ELECT 4.7μF 20%	50V	D1623	8-719-801-78	DIODE 1SS184	
C1611	1-104-668-11	ELECT 33μF 20%	35V	D1626	8-719-404-49	DIODE MA111	
C1612	1-136-257-00	FILM 0.0039μF 5%	50V	D1627	8-719-404-49	DIODE MA111	
C1613	1-163-009-11	CERAMIC CHIP 0.001μF 10%	50V	D1628	8-719-404-49	DIODE MA111	
C1614	1-163-021-91	CERAMIC CHIP 0.01μF 10%	50V	D1635	8-719-404-49	DIODE MA111	
C1615	1-107-901-11	ELECT 0.47μF 20%	50V	D1699	8-719-404-49	DIODE MA111	
C1620	1-163-133-00	CERAMIC CHIP 470PF 5%	50V			<FUSE>	
C1621	1-163-117-00	CERAMIC CHIP 100PF 5%	50V	F1601	△ 1-532-777-21	FUSE, MICRO (SECONDARY) 1.25A/125V	
C1641	1-163-035-00	CERAMIC CHIP 0.047μF	50V	F1602	△ 1-532-747-11	FUSE, GLASS TUBE (H.B.C) 5A/125V (PVM-8042Q, 8045Q, 9045PM)	
C1642	1-126-964-11	ELECT 10μF 20%	50V	F1602	△ 1-576-232-11	FUSE, (H.B.C.) 5A/250V (PVM-9042QM, 9045QM)	
C1643	1-126-964-11	ELECT 10μF 20%	50V				
		<CONNECTOR>					
CN501	* 1-564-506-11	PLUG, CONNECTOR 3P				<IC>	
CN502	* 1-564-011-11	PIN, CONNECTOR 12P					
CN504	* 1-564-508-11	PLUG, CONNECTOR 5P		IC501	8-759-909-70	IC CX23025 (PVM-8042Q, 8045Q, 9042QM, 9045QM)	
CN505	* 1-564-509-11	PLUG, CONNECTOR 6P		IC502	8-759-100-60	IC UPC1377C	
CN507	* 1-564-511-11	PLUG, CONNECTOR 8P		IC503	8-759-801-98	IC LA7830	
CN508	* 1-580-837-11	PIN, CONNECTOR (PC BOARD) 3P		IC504	8-759-231-58	IC TA7812S	
CN509	* 1-564-506-11	PLUG, CONNECTOR 3P		IC505	8-759-009-51	IC MC14538BF	



Ref.No.	Part No.	Description	Remark	Ref.No.	Part No.	Description	Remark
IC506	8-759-209-54	IC TC4S01F		Q1603	8-729-120-28	TRANSISTOR 2SC1623-L5L6	
IC507	8-759-209-69	IC TC4S11F		Q1604	8-729-216-22	TRANSISTOR 2SA1162-G	
IC831	8-759-473-06	IC BU4011BF-E2		Q1605	8-729-119-80	TRANSISTOR 2SC2688-LK	
IC832	8-759-473-07	IC BU4070BF-E2		Q1606	8-729-133-42	TRANSISTOR 2SC2334-L	
IC833	8-759-009-51	IC MC14538BF		Q1607	8-729-120-28	TRANSISTOR 2SC1623-L5L6	
IC1601	8-759-510-73	IC BA10393F-E2		Q1608	8-729-120-28	TRANSISTOR 2SC1623-L5L6	
		<CHIP CONDUCTOR>		Q1609	8-729-120-28	TRANSISTOR 2SC1623-L5L6	
JR507	1-216-295-91	SHORT 0 (PVM-8042Q, 8045Q, 9042QM, 9045QM)		Q1610	8-729-120-28	TRANSISTOR 2SC1623-L5L6	
JR510	1-216-295-91	SHORT 0		Q1611	8-729-120-28	TRANSISTOR 2SC1623-L5L6	
JR518	1-216-295-91	SHORT 0		Q1612	8-729-120-28	TRANSISTOR 2SC1623-L5L6	
JR601	1-216-295-91	SHORT 0		Q1613	8-729-120-28	TRANSISTOR 2SC1623-L5L6	
JR602	1-216-295-91	SHORT 0		Q1614	8-729-120-28	TRANSISTOR 2SC1623-L5L6	
		<COIL>		Q1615	8-729-216-22	TRANSISTOR 2SA1162-G	
L501	1-414-502-41	INDUCTOR 33mH		Q1616	8-729-216-22	TRANSISTOR 2SA1162-G	
L502	1-410-665-31	INDUCTOR 15μH		Q1617	8-729-216-22	TRANSISTOR 2SA1162-G	
L503	1-424-625-11	INDUCTOR 381.4μH		Q1618	8-729-216-22	TRANSISTOR 2SA1162-G	
L506	1-412-530-31	INDUCTOR 27μH		Q1619	8-729-120-28	TRANSISTOR 2SC1623-L5L6	
L1601	1-459-155-00	COIL (WITH CORE) 45μH		Q1620	8-729-120-28	TRANSISTOR 2SC1623-L5L6	
L1602	1-402-785-11	INDUCTOR 600μH				<RESISTOR>	
L1603	1-410-397-21	FERRITE 1.1μH		R501	1-216-089-91	RES,CHIP 47K 5% 1/10W (PVM-8042Q, 8045Q, 9042QM, 9045QM)	
		<TRANSISTOR>		R502	1-216-089-91	RES,CHIP 47K 5% 1/10W (PVM-8042Q, 8045Q, 9042QM, 9045QM)	
Q501	1-801-806-11	TRANSISTOR DTC144EKA-T146 (PVM-8042Q, 8045Q, 9042QM, 9045QM)		R503	1-249-437-11	CARBON 47K 5% 1/4W F (PVM-8042Q, 8045Q, 9042QM, 9045QM)	
Q502	1-801-806-11	TRANSISTOR DTC144EKA-T146 (PVM-8042Q, 8045Q, 9042QM, 9045QM)		R504	1-216-073-00	RES,CHIP 10K 5% 1/10W	
Q503	8-729-901-06	TRANSISTOR DTA144EK (PVM-8042Q, 8045Q, 9042QM, 9045QM)		R505	1-249-393-11	CARBON 10 5% 1/4W F	
Q504	1-801-806-11	TRANSISTOR DTC144EKA-T146 (PVM-8042Q, 8045Q, 9042QM, 9045QM)		R506	1-216-071-00	RES,CHIP 8.2K 5% 1/10W	
Q505	8-729-120-28	TRANSISTOR 2SC1623-L5L6		R507	1-216-059-00	RES,CHIP 2.7K 5% 1/10W	
Q508	8-729-120-28	TRANSISTOR 2SC1623-L5L6		R508	1-216-085-00	RES,CHIP 33K 5% 1/10W	
Q509	8-729-120-28	TRANSISTOR 2SC1623-L5L6		R509	1-216-687-11	METAL CHIP 33K 0.50% 1/10W	
Q512	8-729-120-28	TRANSISTOR 2SC1623-L5L6		R510	1-216-683-11	METAL CHIP 22K 0.50% 1/10W	
Q513	8-729-216-22	TRANSISTOR 2SA1162-G		R511	1-216-675-11	METAL CHIP 10K 0.50% 1/10W	
Q514	8-729-216-22	TRANSISTOR 2SA1162-G		R512	1-218-761-11	METAL CHIP 240K 0.50% 1/10W	
Q515	8-729-313-42	TRANSISTOR 2SD1134-C		R513	1-216-065-91	RES,CHIP 4.7K 5% 1/10W	
Q518	8-729-120-28	TRANSISTOR 2SC1623-L5L6		R514	1-218-754-11	METAL CHIP 120K 0.50% 1/10W (PVM-8042Q, 8045Q, 9042QM, 9045QM)	
Q519	8-729-120-28	TRANSISTOR 2SC1623-L5L6		R515	1-216-081-00	RES,CHIP 22K 5% 1/10W	
Q532	8-729-120-28	TRANSISTOR 2SC1623-L5L6		R516	1-216-073-00	RES,CHIP 10K 5% 1/10W	
Q569	8-729-907-26	TRANSISTOR IMX1		R517	1-218-762-11	METAL CHIP 270K 0.50% 1/10W	
Q570	8-729-901-00	TRANSISTOR DTC124EK		R518	1-249-422-11	CARBON 2.7K 5% 1/4W F	
Q571	8-729-901-00	TRANSISTOR DTC124EK		R519	1-216-085-00	RES,CHIP 33K 5% 1/10W	
Q576	1-801-806-11	TRANSISTOR DTC144EKA-T146		R520	1-216-677-11	METAL CHIP 12K 0.50% 1/10W	
Q579	8-729-920-48	TRANSISTOR IMH2		R521	1-216-067-00	RES,CHIP 5.6K 5% 1/10W	
Q599	8-729-920-48	TRANSISTOR IMH2		R522	1-216-107-00	RES,CHIP 270K 5% 1/10W (PVM-8042Q, 8045Q, 9042QM, 9045QM)	
Q600	8-729-901-00	TRANSISTOR DTC124EK		R523	1-216-081-00	RES,CHIP 22K 5% 1/10W	
Q601	8-729-901-00	TRANSISTOR DTC124EK		R524	1-216-049-91	RES,CHIP 1K 5% 1/10W	
Q833	8-729-216-22	TRANSISTOR 2SA1162-G		R525	1-216-434-11	METAL OXIDE 1.8K 5% 1W F	
Q834	8-729-120-28	TRANSISTOR 2SC1623-L5L6		R526	1-216-079-00	RES,CHIP 18K 5% 1/10W	
Q835	8-729-120-28	TRANSISTOR 2SC1623-L5L6		R527	1-249-437-11	CARBON 47K 5% 1/4W F	
Q836	8-729-255-12	TRANSISTOR 2SC2551-O		R528	1-216-073-00	RES,CHIP 10K 5% 1/10W	
Q1601	8-729-120-28	TRANSISTOR 2SC1623-L5L6		R529	1-216-073-00	RES,CHIP 10K 5% 1/10W	
Q1602	8-729-120-28	TRANSISTOR 2SC1623-L5L6		R530	1-216-089-91	RES,CHIP 47K 5% 1/10W	
				R531	1-216-089-91	RES,CHIP 47K 5% 1/10W (PVM-8042Q, 8045Q, 9042QM, 9045QM)	
				R532	1-216-097-91	RES,CHIP 100K 5% 1/10W	



Ref.No.	Part No.	Description	Remark	Ref.No.	Part No.	Description	Remark
R533	1-216-089-91	RES,CHIP	47K 5% 1/10W	R835	1-216-081-00	RES,CHIP	22K 5% 1/10W
R534	1-216-097-91	RES,CHIP	100K 5% 1/10W	R836	1-216-049-91	RES,CHIP	1K 5% 1/10W
R535	1-216-053-00	RES,CHIP	1.5K 5% 1/10W	R837	1-216-075-00	RES,CHIP	12K 5% 1/10W
R536	1-212-881-11	FUSIBLE	100 5% 1/4W F	R838	1-216-049-91	RES,CHIP	1K 5% 1/10W
R537	1-215-867-00	METAL OXIDE	470 5% 1W F	R839	1-216-061-00	RES,CHIP	3.3K 5% 1/10W
R538	1-216-095-00	RES,CHIP	82K 5% 1/10W	R840	1-216-097-91	RES,CHIP	100K 5% 1/10W
R539	1-216-095-00	RES,CHIP	82K 5% 1/10W	R841	1-216-093-00	RES,CHIP	68K 5% 1/10W
R540	1-216-101-00	RES,CHIP	150K 5% 1/10W	R842	1-216-093-00	RES,CHIP	68K 5% 1/10W
R541	1-216-063-91	RES,CHIP	3.9K 5% 1/10W	R843	1-216-065-91	RES,CHIP	4.7K 5% 1/10W
R542	1-216-075-00	RES,CHIP	12K 5% 1/10W	R844	1-216-077-00	RES,CHIP	15K 5% 1/10W
R543	1-216-065-91	RES,CHIP	4.7K 5% 1/10W	R847	1-216-049-91	RES,CHIP	1K 5% 1/10W
R544	1-216-101-00	RES,CHIP	150K 5% 1/10W	R850	1-216-085-00	RES,CHIP	33K 5% 1/10W
R545	1-216-033-00	RES,CHIP	220 5% 1/10W	R851	1-216-669-11	METAL CHIP	5.6K 0.50% 1/10W
R546	1-216-091-00	RES,CHIP	56K 5% 1/10W	R852	1-216-675-11	METAL CHIP	10K 0.50% 1/10W
R547	1-216-121-91	RES,CHIP	1M 5% 1/10W	R853	1-216-105-91	RES,CHIP	220K 5% 1/10W
R548	1-216-107-00	RES,CHIP	270K 5% 1/10W	R854	1-218-754-11	METAL CHIP	120K 0.50% 1/10W
R549	1-216-101-00	RES,CHIP	150K 5% 1/10W	R855	1-216-697-91	METAL CHIP	82K 0.50% 1/10W
R550	1-216-357-00	METAL OXIDE	4.7 5% 1W F	R856	1-216-699-11	METAL CHIP	100K 0.50% 1/10W
R552	1-216-061-00	RES,CHIP	3.3K 5% 1/10W	R857	1-216-686-11	METAL CHIP	30K 0.50% 1/10W
R553	1-216-689-11	RES,CHIP	39K 5% 1/10W	R858	1-216-061-00	RES,CHIP	3.3K 5% 1/10W
R554	1-216-073-00	RES,CHIP	10K 5% 1/10W	R859	1-216-436-00	METAL OXIDE	3.9K 5% 1W F
R555	1-216-077-00	RES,CHIP	15K 5% 1/10W	R860	1-216-675-11	METAL CHIP	10K 0.50% 1/10W
R557	1-216-057-00	RES,CHIP	2.2K 5% 1/10W	R861	1-216-671-11	METAL CHIP	6.8K 0.50% 1/10W
R558	1-216-049-91	RES,CHIP	1K 5% 1/10W	R862	1-216-675-11	METAL CHIP	10K 0.50% 1/10W
R559	1-216-065-91	RES,CHIP	4.7K 5% 1/10W	R863	1-249-435-11	CARBON	33K 5% 1/4W F
R560	1-216-037-00	RES,CHIP	330 5% 1/10W	R1503	1-216-049-91	RES,CHIP	1K 5% 1/10W
R561	1-216-081-00	RES,CHIP	22K 5% 1/10W	R1504	1-216-695-11	METAL CHIP	68K 0.50% 1/10W
R562	1-216-053-00	RES,CHIP	1.5K 5% 1/10W	R1505	1-216-089-91	RES,CHIP	47K 5% 1/10W
R563	1-216-061-00	RES,CHIP	3.3K 5% 1/10W	R1506	1-216-667-11	METAL CHIP	4.7K 0.50% 1/10W
R564	1-249-415-11	CARBON	680 5% 1/4W F	R1507	1-216-081-00	RES,CHIP	22K 5% 1/10W
R565	1-216-059-00	RES,CHIP	2.7K 5% 1/10W (PVM-8042Q, 8045Q, 9042QM, 9045QM)	R1508	1-216-073-00	RES,CHIP	10K 5% 1/10W
R566	1-216-025-91	RES,CHIP	100 5% 1/10W (PVM-8042Q, 8045Q, 9042QM, 9045QM)	R1509	1-216-065-91	RES,CHIP	4.7K 5% 1/10W
R567	1-216-095-00	RES,CHIP	82K 5% 1/10W	R1510	1-249-425-11	CARBON	4.7K 5% 1/4W F
R568	1-216-063-91	RES,CHIP	3.9K 5% 1/10W	R1511	1-216-033-00	RES,CHIP	220 5% 1/10W
R569	1-216-063-91	RES,CHIP	3.9K 5% 1/10W	R1512	1-216-049-91	RES,CHIP	1K 5% 1/10W
R570	1-216-093-00	RES,CHIP	68K 5% 1/10W	R1513	1-216-017-91	RES,CHIP	47 5% 1/10W
R571	1-216-089-91	RES,CHIP	47K 5% 1/10W	R1519	1-216-025-91	RES,CHIP	100 5% 1/10W
R572	1-216-095-00	RES,CHIP	82K 5% 1/10W	R1520	1-216-053-00	RES,CHIP	1.5K 5% 1/10W
R573	1-216-063-91	RES,CHIP	3.9K 5% 1/10W	R1601	1-216-685-11	METAL CHIP	27K 0.50% 1/10W
R574	1-216-063-91	RES,CHIP	3.9K 5% 1/10W	R1602	1-216-681-11	METAL CHIP	18K 0.50% 1/10W
R575	1-216-105-91	RES,CHIP	220K 5% 1/10W	R1603	1-216-671-11	METAL CHIP	6.8K 0.50% 1/10W
R576	1-216-109-00	RES,CHIP	330K 5% 1/10W	R1604	1-249-433-11	CARBON	22K 5% 1/4W F
R577	1-216-105-91	RES,CHIP	220K 5% 1/10W	R1605	1-216-070-00	RES,CHIP	7.5K 5% 1/10W
R578	1-249-457-71	CARBON	6.8 5% 1/4W F	R1606	1-216-070-00	RES,CHIP	7.5K 5% 1/10W
R579	1-249-457-71	CARBON	6.8 5% 1/4W F	R1607	1-216-071-00	RES,CHIP	8.2K 5% 1/10W
R589	1-216-101-00	RES,CHIP	150K 5% 1/10W (PVM-8042Q, 8045Q, 9042QM, 9045QM)	R1608	1-216-065-91	RES,CHIP	4.7K 5% 1/10W
R591	1-216-063-91	RES,CHIP	3.9K 5% 1/10W	R1609	1-216-069-00	RES,CHIP	6.8K 5% 1/10W
R592	1-216-033-00	RES,CHIP	220 5% 1/10W	R1610	1-216-057-00	RES,CHIP	2.2K 5% 1/10W
R593	1-216-101-00	RES,CHIP	150K 5% 1/10W	R1611	1-216-057-00	RES,CHIP	2.2K 5% 1/10W
R594	1-216-065-91	RES,CHIP	4.7K 5% 1/10W	R1612	1-215-913-11	METAL OXIDE	220 5% 3W F
R600	1-216-069-00	RES,CHIP	6.8K 5% 1/10W	R1613	1-216-025-91	RES,CHIP	100 5% 1/10W
R601	1-216-061-00	RES,CHIP	3.3K 5% 1/10W	R1614	1-216-067-00	RES,CHIP	5.6K 5% 1/10W
R831	1-216-049-91	RES,CHIP	1K 5% 1/10W	R1615	1-216-657-11	METAL CHIP	1.8K 0.50% 1/10W
R832	1-216-075-00	RES,CHIP	12K 5% 1/10W	R1616	1-216-629-11	METAL CHIP	120 0.50% 1/10W
R833	1-216-065-91	RES,CHIP	4.7K 5% 1/10W	R1617	1-216-659-11	METAL CHIP	2.2K 0.50% 1/10W
R834	1-216-059-00	RES,CHIP	2.7K 5% 1/10W	R1618	1-216-073-00	RES,CHIP	10K 5% 1/10W
				R1620	1-216-065-91	RES,CHIP	4.7K 5% 1/10W
				R1621	1-216-073-00	RES,CHIP	10K 5% 1/10W

Ref.No.	Part No.	Description	Remark	Ref.No.	Part No.	Description	Remark
R1622	1-216-073-00	RES,CHIP	10K 5% 1/10W	RV517	1-241-760-11	RES, ADJ, CARBON 470	
R1623	1-216-073-00	RES,CHIP	10K 5% 1/10W	RV518	1-241-763-11	RES, ADJ, CARBON 4.7K	
R1624	1-216-246-00	RES,CHIP	100K 5% 1/8W				
R1625	1-216-061-00	RES,CHIP	3.3K 5% 1/10W	RV831	1-228-997-00	RES, ADJ, METAL GLAZE 100K	
R1626	1-216-065-91	RES,CHIP	4.7K 5% 1/10W	RV832	1-241-764-11	RES, ADJ, CERMET 10K	
R1627	1-216-049-91	RES,CHIP	1K 5% 1/10W	RV833	RES, ADJ, METAL GLAZE 47K		
R1628	1-216-073-00	RES,CHIP	10K 5% 1/10W	RV1601	1-241-762-11	RES, ADJ, CERMET 2.2K	
R1629	1-216-683-11	METAL CHIP	22K 0.50% 1/10W	RV1602	1-241-761-11	RES, ADJ, CARBON 1K	
R1630	1-216-683-11	METAL CHIP	22K 0.50% 1/10W	RV1603	RES, ADJ, METAL GLAZE 47K		
R1631	1-216-057-00	RES,CHIP	2.2K 5% 1/10W				
R1632	1-216-042-00	RES,CHIP	510 5% 1/10W		<RELAY>		
R1633	1-216-109-00	RES,CHIP	330K 5% 1/10W	RY1601	1-755-022-11	RELAY, POWER	
R1634	1-216-099-00	RES,CHIP	120K 5% 1/10W				
R1635	1-216-097-91	RES,CHIP	100K 5% 1/10W		<TRANSFORMER>		
R1636	1-216-073-00	RES,CHIP	10K 5% 1/10W	T1601	1-437-216-11	TRANSFORMER, DRIVE	
R1640	1-216-063-91	RES,CHIP	3.9K 5% 1/10W				
R1641	1-216-073-00	RES,CHIP	10K 5% 1/10W				
R1642	1-216-073-00	RES,CHIP	10K 5% 1/10W				
R1643	1-216-069-00	RES,CHIP	6.8K 5% 1/10W				
R1644	1-216-069-00	RES,CHIP	6.8K 5% 1/10W				
R1645	1-216-073-00	RES,CHIP	10K 5% 1/10W				
R1646	1-216-073-00	RES,CHIP	10K 5% 1/10W				
R1647	1-216-685-11	METAL CHIP	27K 0.50% 1/10W				
R1648	1-216-069-00	RES,CHIP	6.8K 5% 1/10W				
R1649	1-216-069-00	RES,CHIP	6.8K 5% 1/10W				
R1650	1-216-069-00	RES,CHIP	6.8K 5% 1/10W				
R1651	1-216-069-00	RES,CHIP	6.8K 5% 1/10W				
R1652	1-216-069-00	RES,CHIP	6.8K 5% 1/10W				
R1653	1-216-069-00	RES,CHIP	6.8K 5% 1/10W				
R1654	1-216-681-11	METAL CHIP	18K 0.50% 1/10W				
R1655	1-216-081-00	RES,CHIP	22K 5% 1/10W				
R1656	1-216-643-11	METAL CHIP	470 0.50% 1/10W				
R1657	1-216-081-00	RES,CHIP	22K 5% 1/10W				
R1658	1-216-063-91	RES,CHIP	3.9K 5% 1/10W				
R1659	1-216-049-91	RES,CHIP	1K 5% 1/10W				
R1660	1-216-649-11	METAL CHIP	820 0.50% 1/10W				
R1661	1-216-065-91	RES,CHIP	4.7K 5% 1/10W				
R1691	1-216-073-00	RES,CHIP	10K 5% 1/10W				
R1692	1-216-081-00	RES,CHIP	22K 5% 1/10W				
R1693	1-216-061-00	RES,CHIP	3.3K 5% 1/10W				
R1694	1-216-081-00	RES,CHIP	22K 5% 1/10W				
R1695	1-216-061-00	RES,CHIP	3.3K 5% 1/10W				
R1696	1-216-073-00	RES,CHIP	10K 5% 1/10W				
		<VARIABLE RESISTOR>					
RV501	1-238-019-11	RES, ADJ, CARBON 47K					
RV502	1-241-765-11	RES, ADJ, CARBON 22K					
RV503	1-241-763-11	RES, ADJ, CERMET 4.7K					
RV504	1-224-250-XX	RES, ADJ, METAL GLAZE 2.2K					
RV505	1-241-759-11	RES, ADJ, CARBON 220					
RV507	1-241-762-11	RES, ADJ, CARBON 2.2K					
RV508	1-241-761-11	RES, ADJ, CARBON 1K					
RV509	1-241-768-11	RES, ADJ, CARBON 220K					
RV511	1-241-763-11	RES, ADJ, CARBON 4.7K					
RV512	1-241-763-11	RES, ADJ, CARBON 4.7K					
RV514	1-238-019-11	RES, ADJ, CARBON 47K					
RV515	1-241-768-11	RES, ADJ, CARBON 220K					
RV516	1-241-763-11	RES, ADJ, CERMET 4.7K					
		<CHIP CONDUCTOR>					
JR003	1-216-295-91	SHORT 0					
JR006	1-216-295-91	SHORT 0					
JR007	1-216-295-91	SHORT 0					
		<TRANSISTOR>					
Q001	8-729-120-28	TRANSISTOR 2SC1623-L5L6					

Ref.No.	Part No.	Description	Remark	Ref.No.	Part No.	Description	Remark
<RESISTOR>				<CAPACITOR>			
R001	1-247-713-11	CARBON 1K 5%	1/4W	C1101	1-163-119-00	CERAMIC CHIP 120PF 5%	50V
R004	1-216-081-00	RES,CHIP 22K 5%	1/10W	C1102	1-164-004-11	CERAMIC CHIP 0.1μF 10%	25V
R006	1-216-049-91	RES,CHIP 1K 5%	1/10W	C1103	1-124-589-11	ELECT 47μF 20%	16V
R007	1-216-049-91	RES,CHIP 1K 5%	1/10W	C1104	1-163-031-11	CERAMIC CHIP 0.01μF	50V
R008	1-216-061-00	RES,CHIP 3.3K 5%	1/10W	C1105	1-163-248-11	CERAMIC CHIP 75PF 5%	50V
R009	1-216-049-91	RES,CHIP 1K 5%	1/10W	C1106	1-163-101-00	CERAMIC CHIP 22PF 5%	50V
R010	1-216-057-00	RES,CHIP 2.2K 5%	1/10W	C1107	1-164-004-11	CERAMIC CHIP 0.1μF 10%	25V
<VARIABLE RESISTOR>				<CONNECTION>			
RV001	1-225-385-11	RES, VAR, CARBON 20K		C1108	1-163-119-00	CERAMIC CHIP 120PF 5%	50V
RV002	1-225-385-11	RES, VAR, CARBON 20K		C1109	1-163-031-11	CERAMIC CHIP 0.01μF	50V
RV003	1-225-385-11	RES, VAR, CARBON 20K		C1110	1-163-117-00	CERAMIC CHIP 100PF 5%	50V
RV004	1-225-385-11	RES, VAR, CARBON 20K		C1111	1-163-018-00	CERAMIC CHIP 0.0056μF 10%	50V
RV005	1-225-385-11	RES, VAR, CARBON 20K		C1112	1-126-160-11	ELECT 1μF 20%	50V
RV006	1-225-385-11	RES, VAR, CARBON 20K		C1113	1-163-119-00	CERAMIC CHIP 120PF 5%	50V
RV007	1-226-773-11	RES, ADJ, METAL GLAZE 22K		C1114	1-163-103-00	CERAMIC CHIP 27PF 5%	50V
RV008	1-226-773-11	RES, ADJ, METAL GLAZE 22K		C1115	1-164-004-11	CERAMIC CHIP 0.1μF 10%	25V
RV009	1-226-773-11	RES, ADJ, METAL GLAZE 22K		C1116	1-163-248-11	CERAMIC CHIP 75PF 5%	50V
RV010	1-226-773-11	RES, ADJ, METAL GLAZE 22K		C1117	1-124-589-11	ELECT 47μF 20%	16V
RV011	1-226-773-11	RES, ADJ, METAL GLAZE 22K		C1118	1-164-004-11	CERAMIC CHIP 0.1μF 10%	25V
RV012	1-226-773-11	RES, ADJ, METAL GLAZE 22K		C1119	1-163-020-00	CERAMIC CHIP 0.0082μF 10%	50V
<SWITCH>				<CONNECTION>			
S001	1-554-419-00	SWITCH, PUSH (1 KEY)		C1120	1-163-231-11	CERAMIC CHIP 15PF 5%	50V
S002	1-554-419-00	SWITCH, PUSH (1 KEY)		C1121	1-163-231-11	CERAMIC CHIP 15PF 5%	50V
S003	1-554-419-00	SWITCH, PUSH (1 KEY)		C1122	1-163-222-11	CERAMIC CHIP 5PF 0.25PF	50V
S004	1-554-419-00	SWITCH, PUSH (1 KEY)		C1123	1-163-097-00	CERAMIC CHIP 15PF 5%	50V
S005	1-554-419-00	SWITCH, PUSH (1 KEY)		C1130	1-163-097-00	CERAMIC CHIP 15PF 5%	50V
S006	1-554-419-00	SWITCH, PUSH (1 KEY)		C1131	1-163-097-00	CERAMIC CHIP 15PF 5%	50V
S007	1-572-522-11	SWITCH, PUSH (1 KEY)		<CONNECTOR>			
S008	1-554-419-00	SWITCH, PUSH (1 KEY)		CN1101	* 1-565-488-11	CONNECTOR, BOARD TO BOARD 12P	
*****				<DIODE>			
*1-641-724-11 PC BOARD, X *****				D1101	8-719-404-49	DIODE MA111	
<CONNECTOR>				D1102	8-719-404-49	DIODE MA111	
CN21	* 1-564-518-11	PLUG, CONNECTOR 3P		<IC>			
<DIODE>				IC1101	8-752-056-67	IC CXA1214P	
D21	8-719-023-78	DIODE SEL3810DLC05		<COIL>			
D22	8-719-023-78	DIODE SEL3810DLC05		L1101	1-408-605-31	INDUCTOR 15μH	
D23	8-719-023-78	DIODE SEL3810DLC05		L1102	1-404-496-00	COIL	
*****				L1103	1-404-496-00	COIL	
* A-1394-917-A S BOARD, COMPLETE *****				L1104	1-408-605-31	INDUCTOR 15μH	
<TRANSISTOR>				L1110	1-412-008-31	INDUCTOR CHIP 15μH	
Q1101	8-729-216-22	TRANSISTOR 2SA1162-G		L1111	1-412-008-31	INDUCTOR CHIP 15μH	
Q1102	8-729-120-28	TRANSISTOR 2SC1623-L5L6		<TRANSISTOR>			
Q1103	8-729-216-22	TRANSISTOR 2SA1162-G		Q1101	8-729-216-22	TRANSISTOR 2SA1162-G	
Q1104	8-729-216-22	TRANSISTOR 2SA1162-G		Q1102	8-729-120-28	TRANSISTOR 2SC1623-L5L6	
Q1105	1-801-806-11	TRANSISTOR DTC144EK-T147		Q1103	8-729-216-22	TRANSISTOR 2SA1162-G	
Q1106	1-801-806-11	TRANSISTOR DTC144EK-T147		Q1104	8-729-216-22	TRANSISTOR 2SA1162-G	
Q1107	8-729-109-44	TRANSISTOR 2SK94-X4		Q1105	1-801-806-11	TRANSISTOR DTC144EK-T147	







Ref.No.	Part No.	Description	Remark	Ref.No.	Part No.	Description	Remark
R607	1-260-128-91	CARBON 270K	5% 1/2W	*****			
R608	1-260-128-91	CARBON 270K	5% 1/2W				
R609	1-215-904-51	METAL OXIDE 100K	5% 2W F				
R610	1-216-341-11	METAL OXIDE 0.22	10% 1/2W	MISCELLANEOUS *****			
R611	1-249-395-11	CARBON 15	5% 1/4W	△ 1-413-720-21 SWITCHING REGULATOR			
R612	1-249-399-11	CARBON 33	5% 1/4W	△ 1-416-882-11 COIL, DEMAGNETIC			
R613	1-215-904-51	METAL OXIDE 100K	5% 2W F	△ 1-451-319-22 DEFLECTION YOKE (Y9FXC)			
R614	1-247-815-91	CARBON 220	5% 1/4W				
R620	1-218-265-11	METAL GRAZE 8.2M	5% 1W	△ 8-737-154-05 PICTURE TUBE SD-167 (PVM-8042Q, 9042QM (AEP))			
R651	1-215-886-11	METAL OXIDE 100	5% 2W F	△ 8-737-651-05 PICTURE TUBE 09FX (PVM-8045Q, 9042QM (AUS), 9045QM (AEP), 9045QM (AUS), 9045PM (BRZ))			
R652	1-215-886-11	METAL OXIDE 100	5% 2W F				
R653	1-260-107-11	CARBON 4.7K	5% 1/2W				
R654	1-260-107-11	CARBON 4.7K	5% 1/2W				
R655	1-249-435-11	CARBON 33K	5% 1/4W				
R656	1-249-435-11	CARBON 33K	5% 1/4W				
R657	1-249-420-11	CARBON 1.8K	5% 1/4W				
R658	1-249-435-11	CARBON 33K	5% 1/4W				
<VARIABLE RESISTOR>							
RV651	△	RES,ADJ,CARBON	1K				
<TRANSFORMER>							
T601	1-450-760-12	TRANSFORMER, CONVERTER					
*****							
ACCESSORIES AND PACKING MATERIALS *****							
1-690-871-11 CABLE (MINI DIN) 8P							
2-990-241-02 HOLDER (A), PLUG							
2-990-242-01 HOLDER (B), PLUG							
3-865-058-11 OPERATING INSTRUCTIONS (PVM-8042Q, 8045Q) (ENGLISH, FRENCH, SPANISH)							
3-865-058-21 OPERATING INSTRUCTIONS (PVM-9042Q, 9045QM) (ENGLISH, FRENCH, GERMAN, ITALIAN, SPANISH, CHINESE)							
3-865-341-11 OPERATING INSTRUCTIONS (PVM-9045PM) (ENGLISH)							
4-034-835-01 PLATE, TALLY							
△ 1-765-718-11 CORD SET, POWER (125V/10.0A) (PVM-8042Q, 8045Q, 9045PM)							
△ 1-782-929-11 CORD, POWER SUPPLY (BS 3P) (250V/10.0A) (PVM-9042QM, 9045QM)							
* 4-034-955-01 CUSHION (UPPER) (ASSY)							
* 4-034-956-01 CUSHION (LOWER) (ASSY)							
* 4-384-927-11 BAG, PROTECTION							

SECTION 9  
BLOCK DIAGRAMS

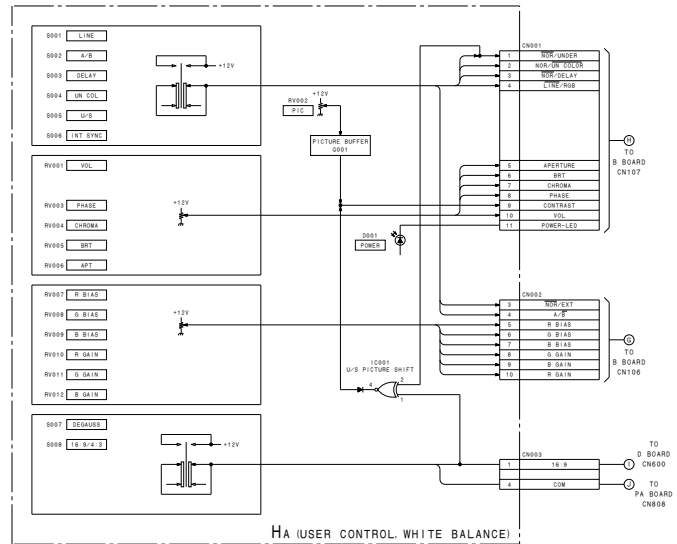
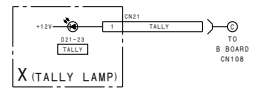
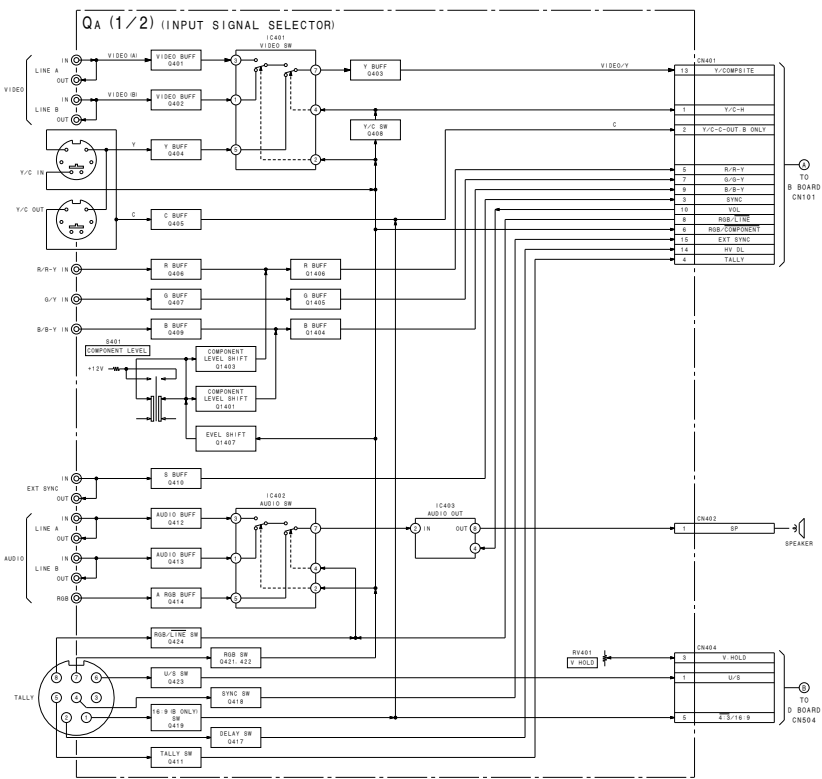

**B B**

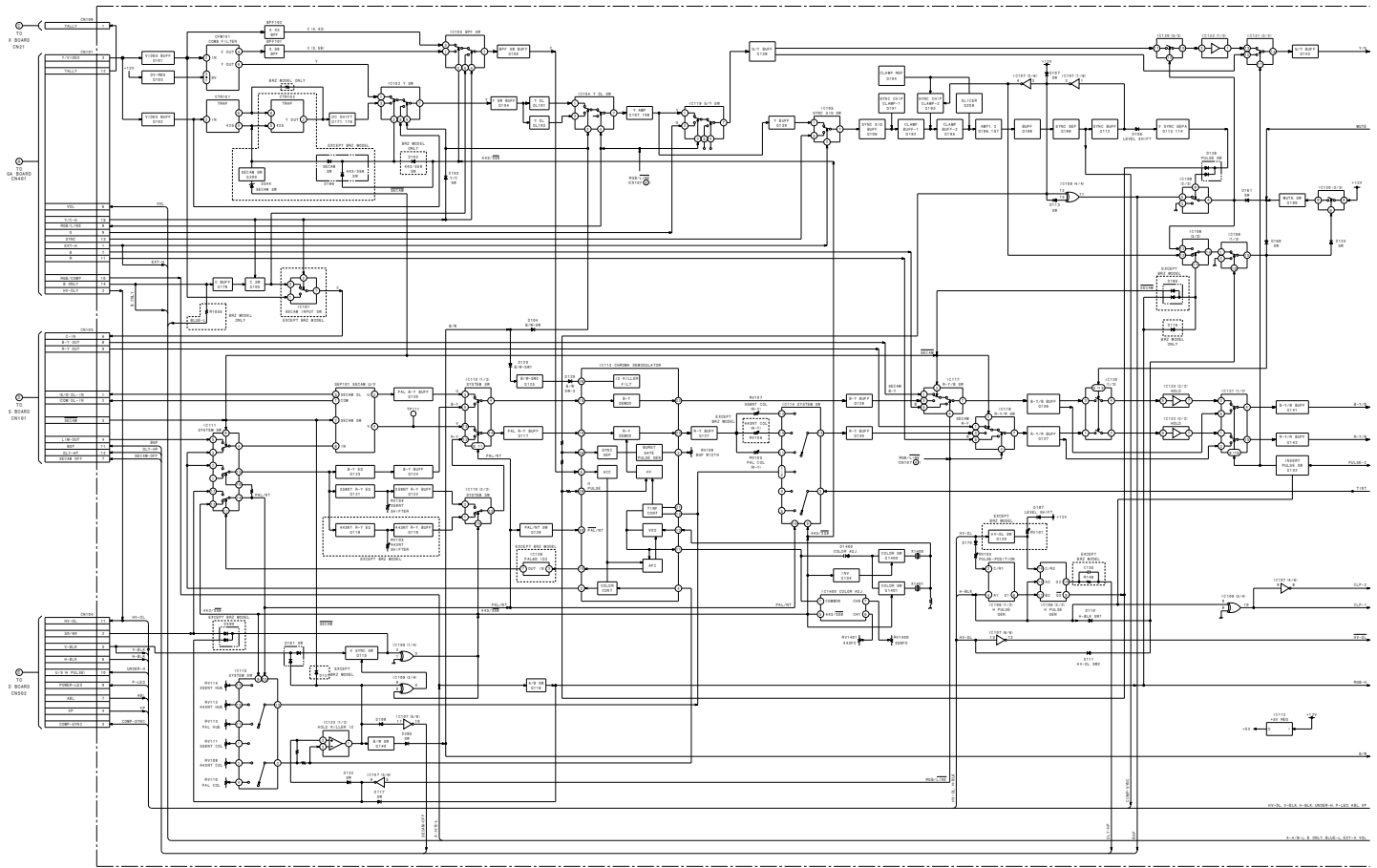

**B B**

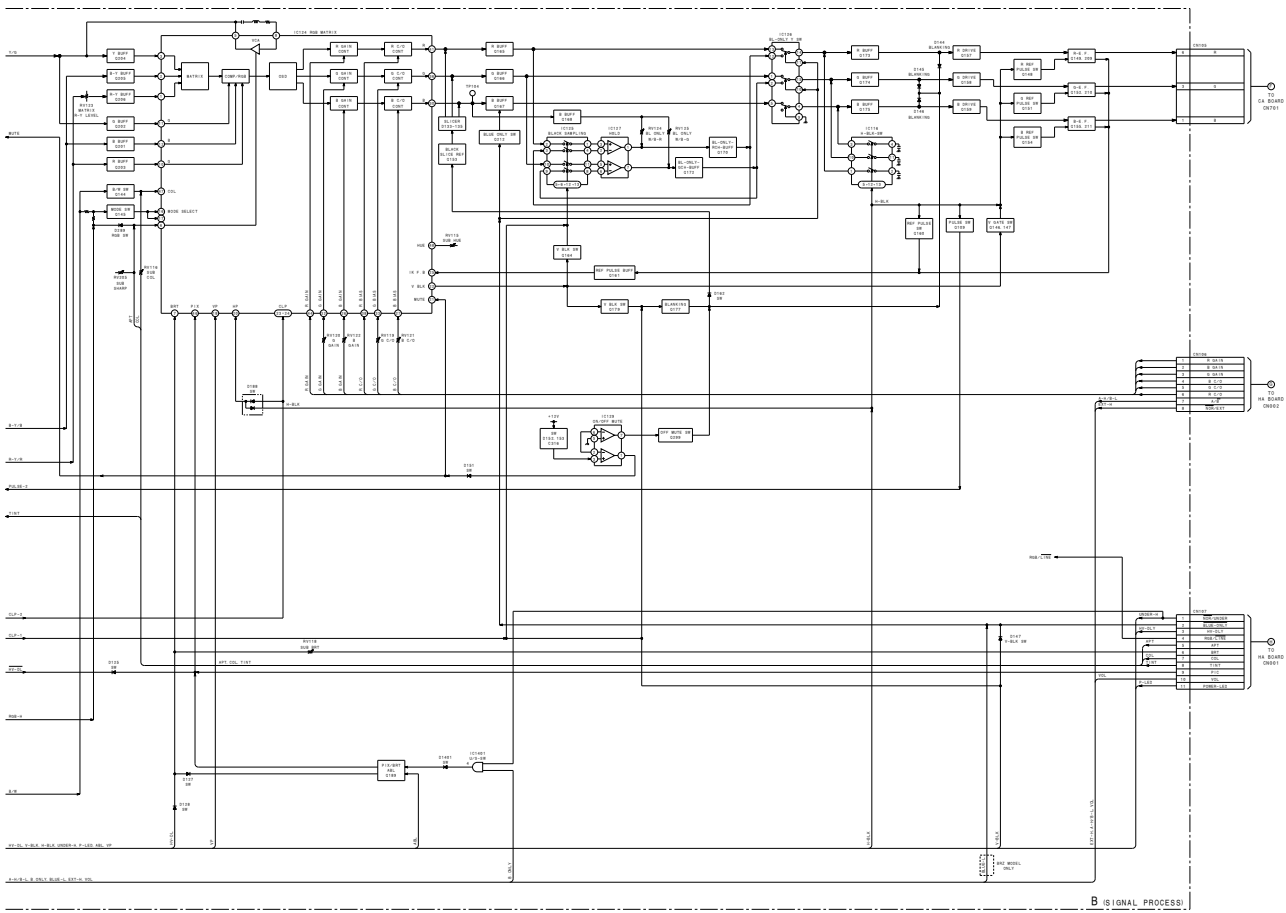

FA, QA (2/2) , S G

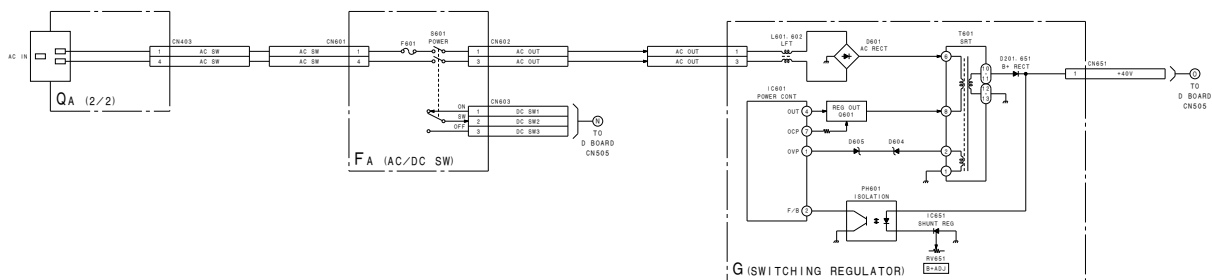
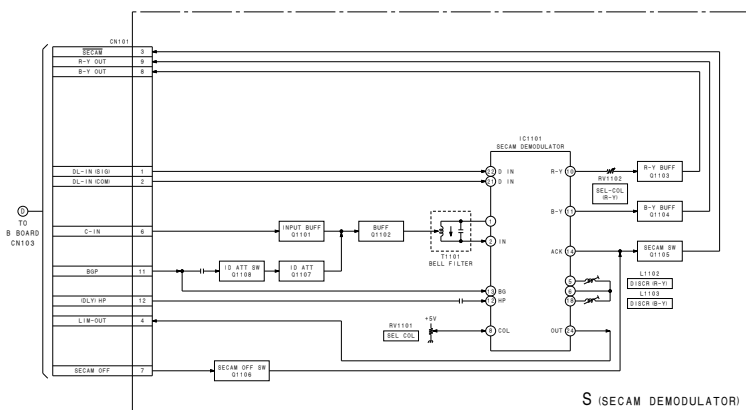

D D

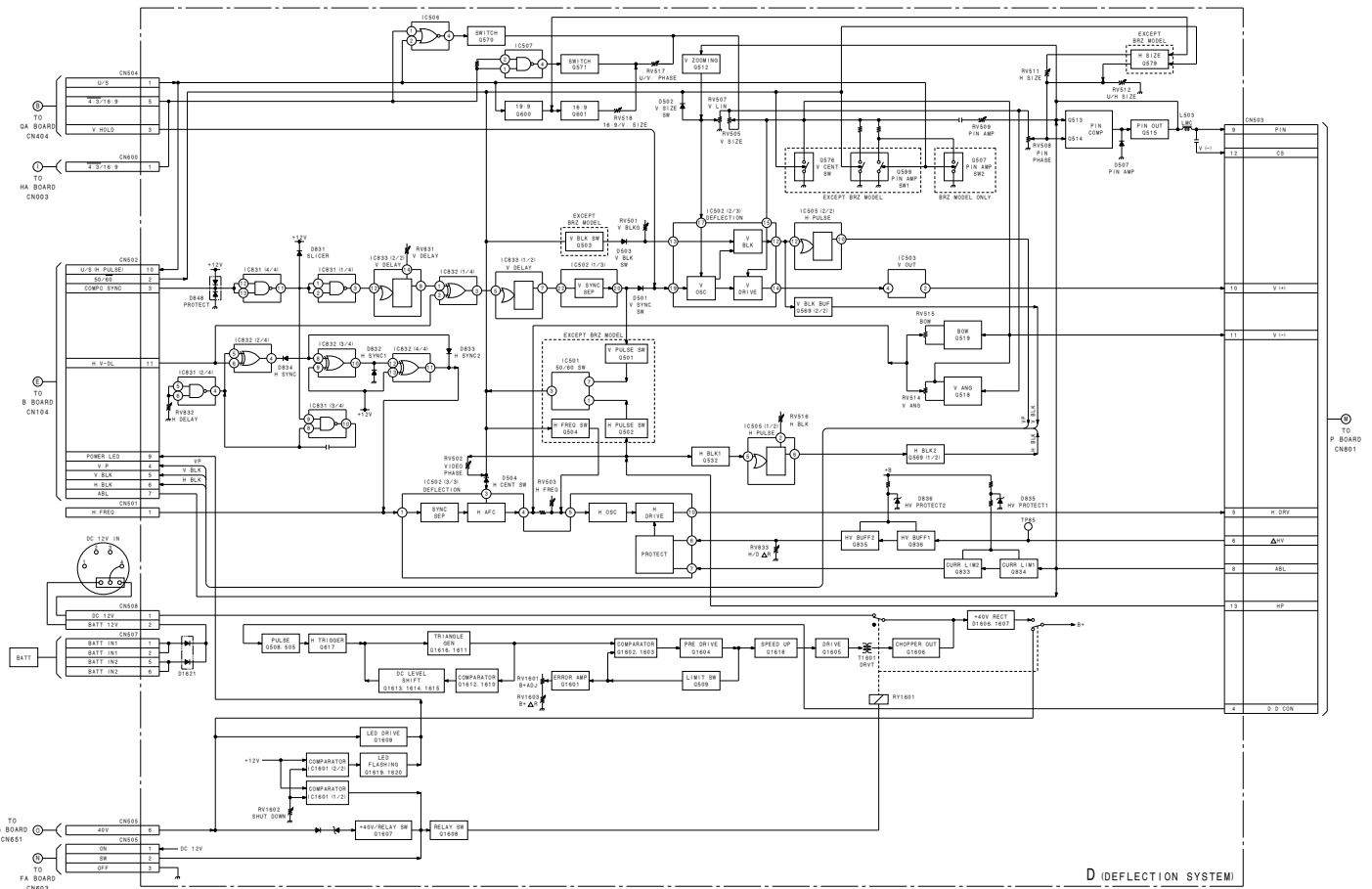

CA, P PA

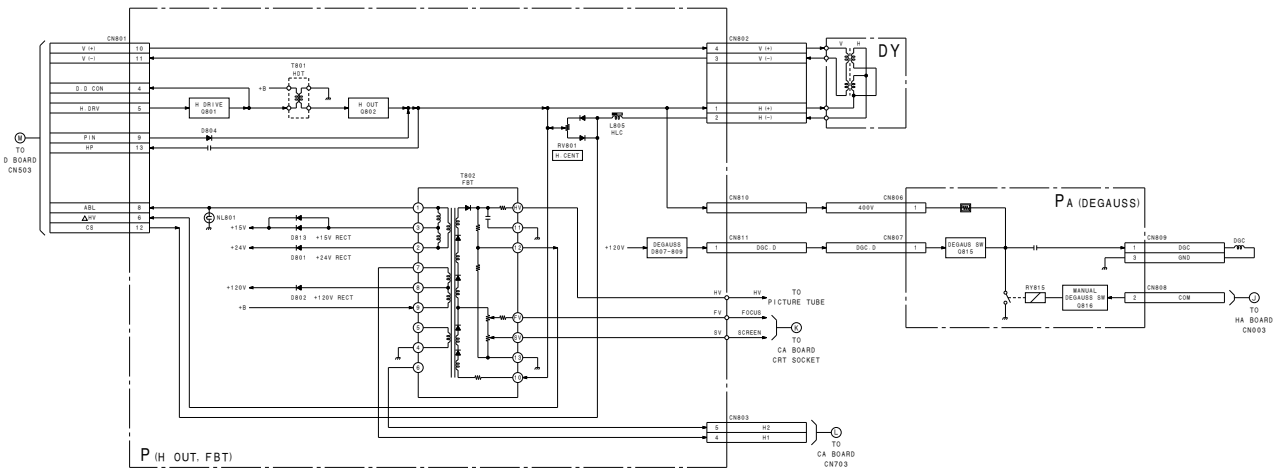
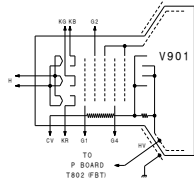
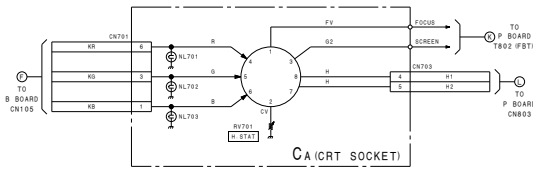



**SECTION 10**  
**DIAGRAMS**

FRAME FRAME

10-1. FRAME SCHEMATIC DIAGRAMS

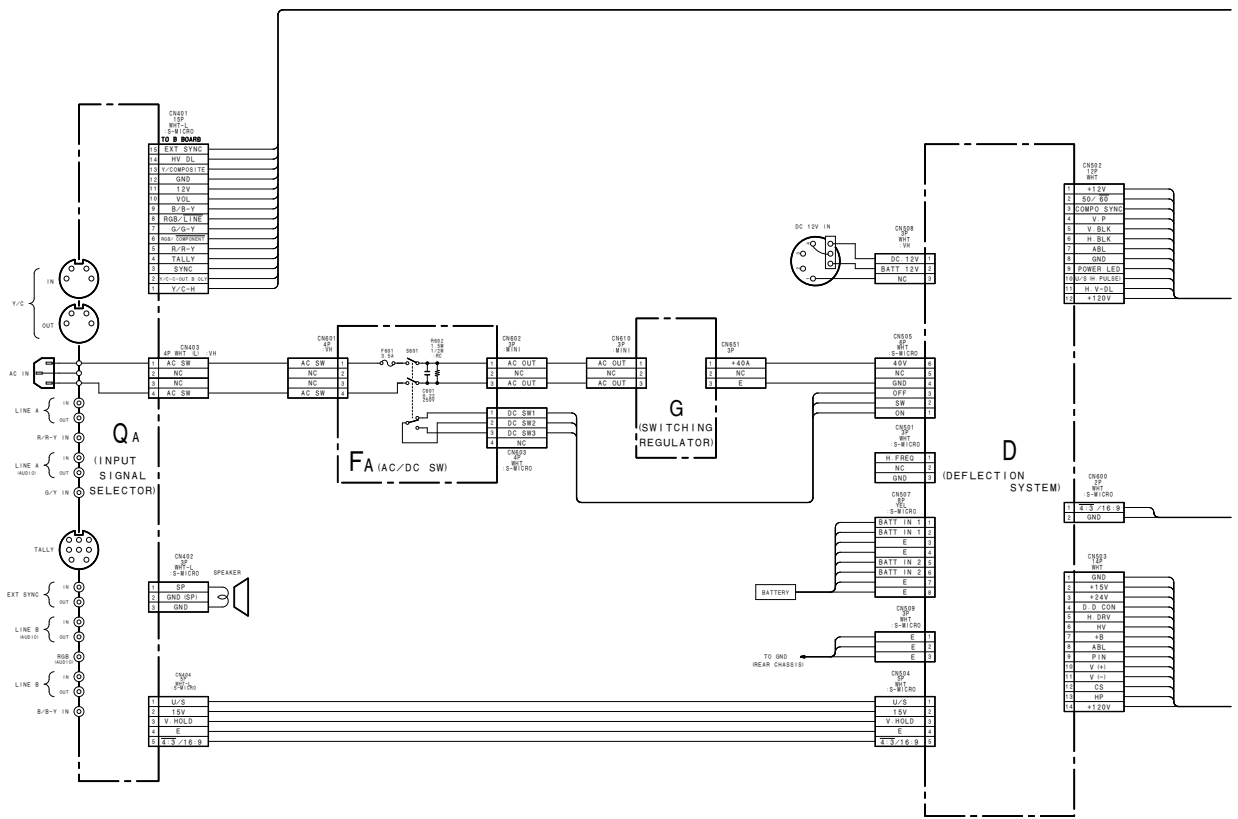

A | B | C | 10-2 | 10-2 | E | F | G | H

S-MIC Chassis

FRAME FRAME

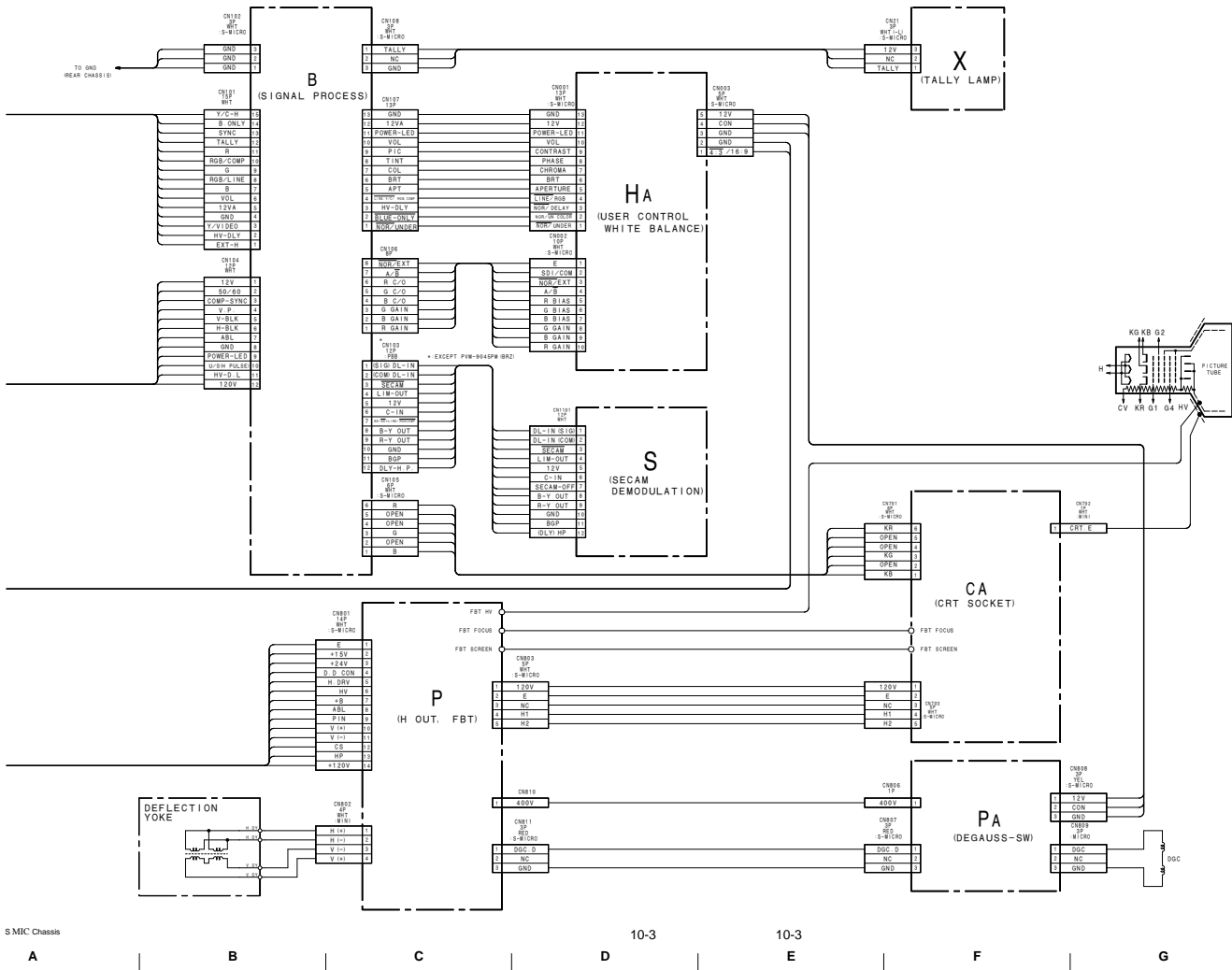

S MIC Chassis 10-3 10-3 A B C D E F G H

10-2. SCHEMATIC DIAGRAMS/PRINTED WIRING BOARDS

- Note:**
- All capacitors are in  $\mu\text{F}$  unless otherwise noted.
  - PF: 50 WV or less are not indicated except for electrolytics.
  - All electrolytics are in 50 V unless otherwise specified.
  - All resistors are in ohms, 1/4 W in resistance, 1/10 W in chip resistance.
  - $k\Omega = 100, M\Omega = 1000 k\Omega$
  - $\overline{W}$ : nonflammable resistor.
  - $\Delta$ : internal component.
  - $\square$ : panel designation, or adjustment for repair.
  - All variable and adjustable resistors have characteristic curve B, unless otherwise noted.
  - The "4-1. +B Voltage Check" and "4-2. Protection Circuit (Hold-down circuit) Check" should always be performed when replacing the following components (marked  $\blacksquare$  on the schematic diagram).

The components identified by mark  $\Delta$  are critical for safety. Replace only with part number specified.

Les composants identifiés par une marque  $\Delta$  sont critiques pour la sécurité. Ne les remplacer que par une pièce portant le numéro spécifié.

- Reference information**
- RESISTOR : RN METAL FILM  
 : RC SOLID  
 : FPRD NONFLAMMABLE CARBON  
 : FUSE NONFLAMMABLE FUSIBLE  
 : RS NONFLAMMABLE METAL OXIDE  
 : RB NONFLAMMABLE CEMENT  
 : RW NONFLAMMABLE WIREWOUND
- COIL  
 CAPACITOR : LF-8L MICRO INDUCTOR  
 : TA TANTALUM  
 : PS STYROL  
 : PP POLYPROPYLENE  
 : PT MYLAR  
 : MPS METALIZED POLYESTER  
 : MPP METALIZED POLYPROPYLENE  
 : ALB BIPOLAR  
 : ALT HIGH TEMPERATURE  
 : ALR HIGH RIPPLE

Board	Parts	Parts
D	C519, C843, C844, C845, C846, C847, C848, C1601, C1602, D835, D836, D1601, D1603, IC502, Q833, Q834, Q835, Q836, Q1601, Q1602, Q1603, R523, R850, R851, R852, R853, R854, R855, R856, R857, R858, R859, R860, R861, R862, R863, R1601, R1602, R1603, R1604, R1605, R1606, R1607, R1608, R1628, R1629, R1630, RV833, RV1601, RV1603	RV833, RV1603
G	C654, IC601, IC651, PH601, R653, R655, R656, R657, RV651	RV651
P	C814, NL801, T802 (FBT)	

- Readings are taken with a color-bar signal input.
- no mark : With PAL color-bar signal received or common voltage.
- ( ) : With SECAM color-bar signal received.
- < : With NTSC (3.58, 4.43) color-bar signal received.
- Readings are taken with a 10 M $\Omega$  digital multimeter.
- Voltage are dc with respect to ground unless otherwise noted.
- Voltage variations may be noted due to normal production tolerances.
- All voltages are in V.
- Circled numbers are waveform reference.
- $\overline{V}$  : B+ bus.
- $\underline{V}$  : B- bus.
- $\Rightarrow$  : signal path.
- \* : Measurement impossibility.

G BOARD

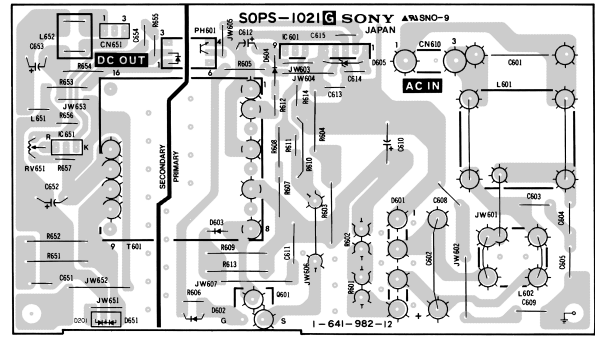

G -B SIDE-  
SUFFIX: -12

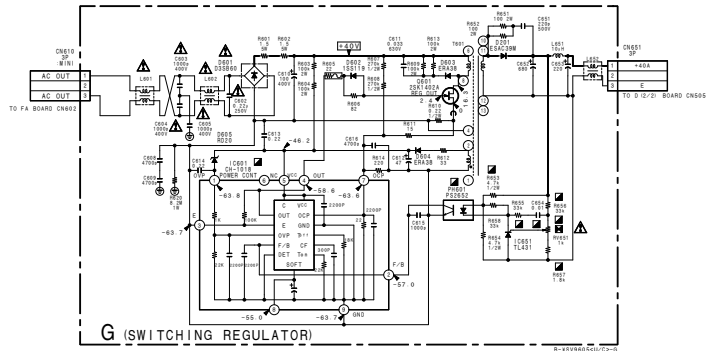

QA BOARD

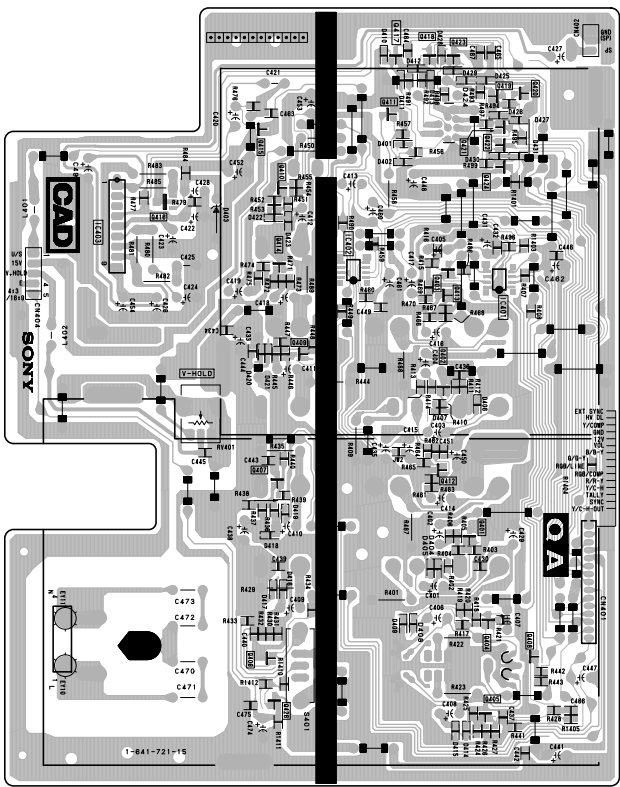

QA - B SIDE - SUFFIX: -15

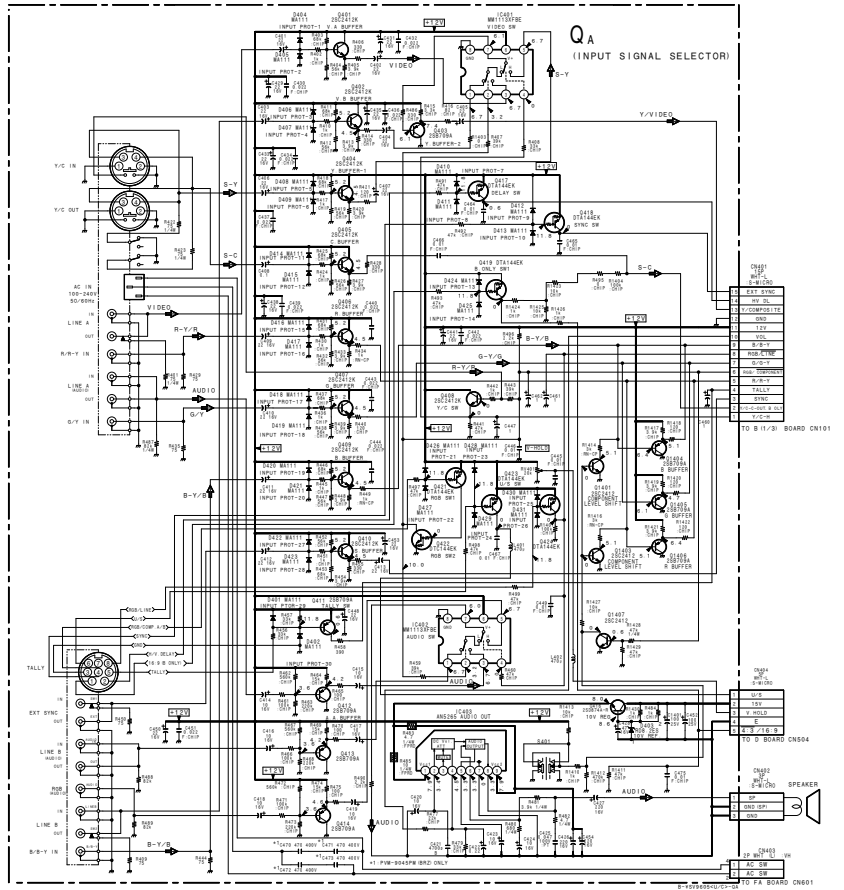

D D

D BOARD

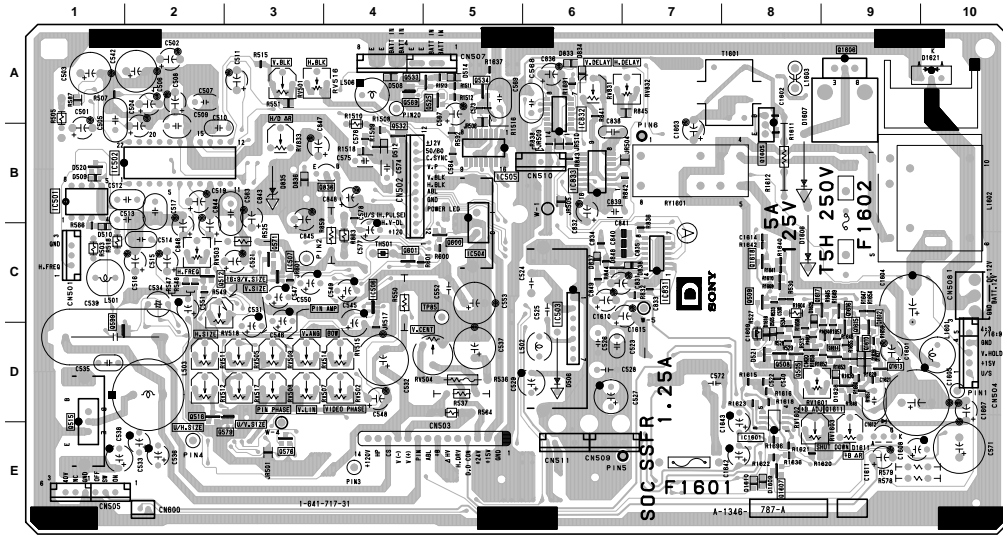

D - A SIDE-  
SUFFIX: -31

D BOARD (A SIDE)

- IC501 B-1
- IC502 B-1
- IC503 C-6
- IC505 B-5
- IC506 C-4
- IC507 C-1
- IC831 C-7
- IC832 A-6
- IC833 B-6
- IC1601 E-8
  
- Q505 D-8
- Q508 D-8
- Q509 C-8
- Q512 C-2
- Q515 D-1
- Q516 D-7
- Q532 B-4
- Q533 A-4
- Q534 A-5
- Q569 A-4
- Q571 C-3
- Q576 E-3
- Q579 B-3
- Q585 A-5
- Q599 D-1
- Q600 C-5
- Q601 C-4
- Q836 B-4
- Q1604 C-2
- Q1605 B-8
- Q1606 A-9
- Q1607 B-8
- Q1610 D-9
- Q1611 C-9
- Q1612 C-9
- Q1613 D-9
- Q1614 D-9
- Q1615 D-9
- Q1616 C-9
- Q1617 C-8
- Q1618 C-8
  
- D506 D-5
- D508 A-4
- D509 B-1
- D510 C-1
- D514 A-5
- D520 B-1
- D521 D-8
- D833 A-6
- D834 A-6
- D835 B-3
- D836 B-3
- D837 C-6
- D838 C-7
- D1606 C-8
- D1607 A-8
- D1609 E-8
- D1611 E-9
- D1616 D-8
- D1621 A-10
- D1625 C-8
- D1626 D-9
- D1627 D-9
- D1628 D-9
  
- RV501 A-3
- RV502 D-4
- RV503 C-2
- RV504 D-5
- RV505 D-3
- RV507 D-4
- RV508 D-3
- RV509 D-3
- RV511 D-2
- RV512 D-2
- RV514 D-4
- RV515 B-4
- RV516 A-4
- RV517 D-3
- RV518 C-2
- RV831 A-6
- RV832 A-7
- RV833 B-3
- RV1601 D-8
- RV1602 E-8
- RV1603 E-9

D D

D BOARD (B SIDE)

- ICS01 B-10
- ICS02 B-9
- ICS03 C-5
- ICS04 C-6

- Q501 B-10
- Q502 C-10
- Q503 A-8
- Q504 B-9
- Q506 C-9
- Q515 B-10
- Q507 C-9
- Q513 B-10
- Q514 B-8
- Q517 B-8
- Q518 D-8
- Q519 C-7
- Q535 B-8
- Q570 D-8
- Q589 B-9
- Q833 B-8
- Q835 B-8
- Q836 B-7
- Q1601 D-1
- Q1602 D-2
- Q1603 D-2
- Q1605 B-3
- Q1606 A-2
- Q1608 D-4
- Q1609 E-3
- Q1619 E-3
- Q1620 E-4

- D501 A-9
- D502 A-8
- D503 A-8
- D504 B-9
- D505 D-8
- D507 D-7
- D511 B-6
- D512 B-4
- D513 D-7
- D515 B-7
- D599 B-9
- D599 D-6
- D831 C-5
- D832 A-5
- D835 B-8
- D836 B-8
- D1601 C-3
- D1602 D-2
- D1603 C-3
- D1604 C-2
- D1605 C-2
- D1608 E-1
- D1610 B-8
- D1611 E-2
- D1612 D-4
- D1613 B-4
- D1614 B-4
- D1615 B-2
- D1617 B-3
- D1618 B-3
- D1620 B-4
- D1621 A-2
- D1622 C-2
- D1623 D-2
- D1635 E-3
- D1699 E-1

- RV501 A-8
- RV502 D-7
- RV503 C-8
- RV504 D-6
- RV505 D-8
- RV507 D-7
- RV508 B-8
- RV509 D-8
- RV511 D-8
- RV512 D-8
- RV514 D-7
- RV515 D-7
- RV516 A-7
- RV517 D-8
- RV518 C-8
- RV831 A-5
- RV832 A-4
- RV833 B-8
- RV1601 D-2
- RV1602 E-2
- RV1603 E-2

S MIC Chassis

D BOARD

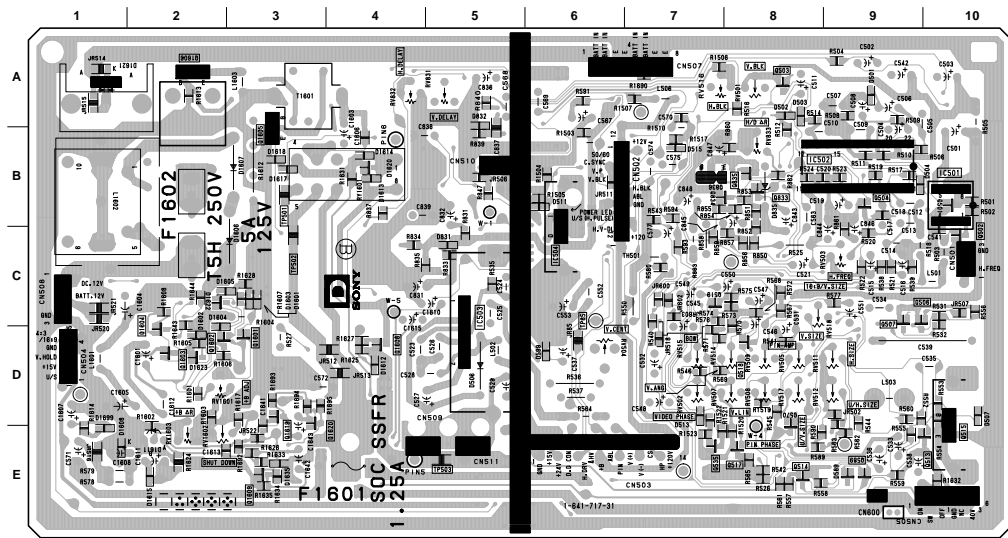

D - B SIDE-  
SUFFIX: -31

FA BOARD

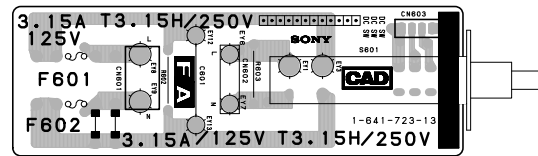

FA - B SIDE-  
SUFFIX: -13

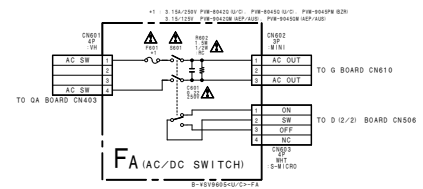

D (1/2) D (1/2)

D (1/2) BOARD IC501 CX23025

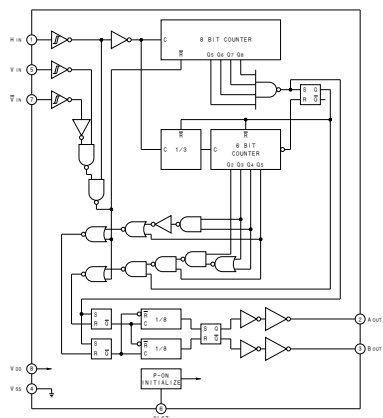

D (1/2) BOARD • MARK LIST

	PVM-8042Q (U/C)	PVM-9045PM (BRZ)
	PVM-8045Q (U/C)	
	PVM-9042QM (AEP/AUS)	
	PVM-9045QM (AEP/AUS)	
C501	47 16V	NOT USED
C518	56P B: CHIP	NOT USED
C541	0.047 B: CHIP	NOT USED
D520	MA157-TX	NOT USED
IC501	CX23025	NOT USED
JR507	NOT USED	SHORT 0
Q501	DTC144EKA-T146	NOT USED
Q502	DTC144EKA-T146	NOT USED
Q503	DTC144EKA-T147	NOT USED
Q504	DTC144EKA-T146	NOT USED
R501	47K :CHIP	NOT USED
R502	47K :CHIP	NOT USED
R503	47K	NOT USED
R514	120K :RN	NOT USED
R522	270K :CHIP	NOT USED
R531	47K :CHIP	NOT USED
R565	2.7K :CHIP	NOT USED
R566	100 :CHIP	NOT USED
R589	150K :CHIP	NOT USED

D (1/2) BOARD WAVEFORMS

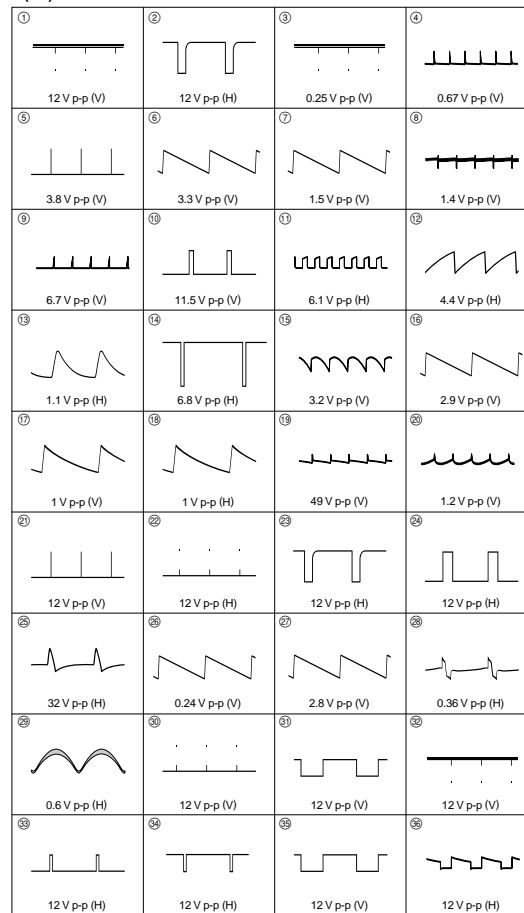

A | B | C | D (10-8) | E (10-8) | F | G | H (S MIC Chassis)





D (2/2) D (2/2)

D (2/2) BOARD

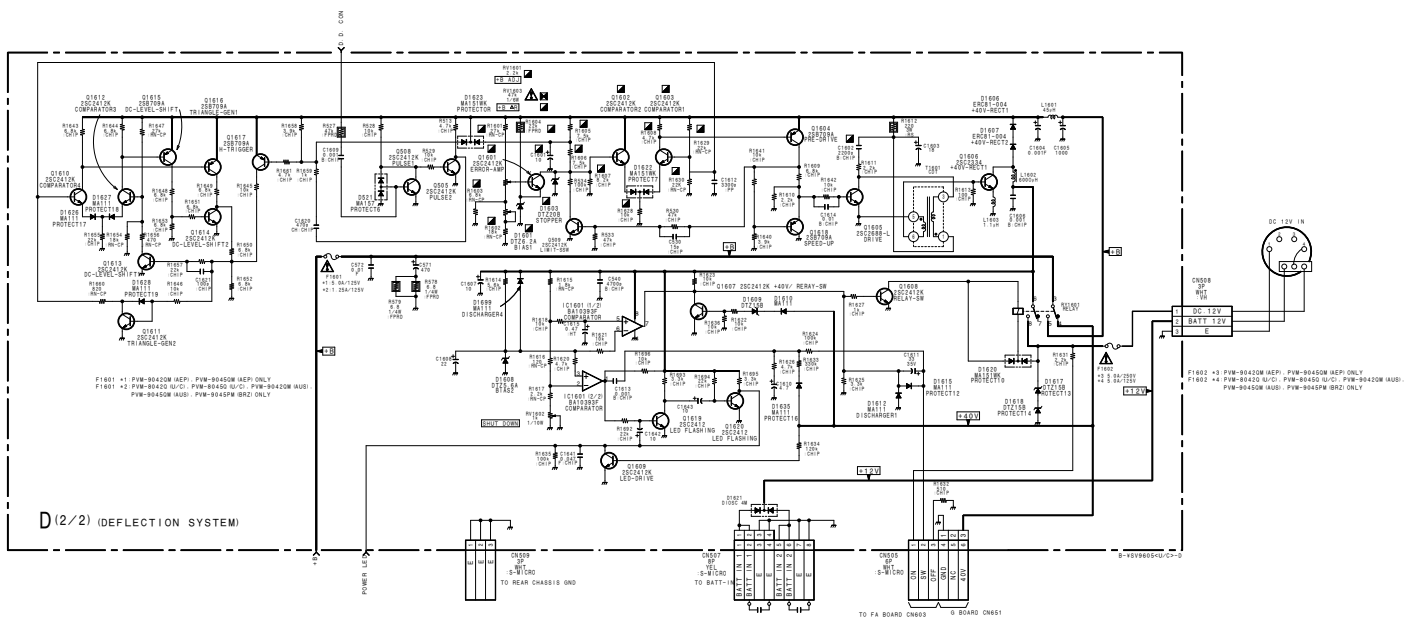

F1601 +1 P/W-80420W MEPI; P/W-80420W MEPI ONLY  
F1601 +2 P/W-80420W IUCI; P/W-80420W IUCI; P/W-80420W IUSI;  
P/W-80420W IUSI; P/W-80420W BRZ ONLY

F1602 +3 P/W-80420W MEPI; P/W-80420W MEPI ONLY  
F1602 +4 P/W-80420W IUCI; P/W-80420W IUCI; P/W-80420W IUSI;  
P/W-80420W IUSI; P/W-80420W BRZ ONLY

A | B | C | D | E | F | G | H

10-10 10-10

S MIC Chassis

P P

P BOARD

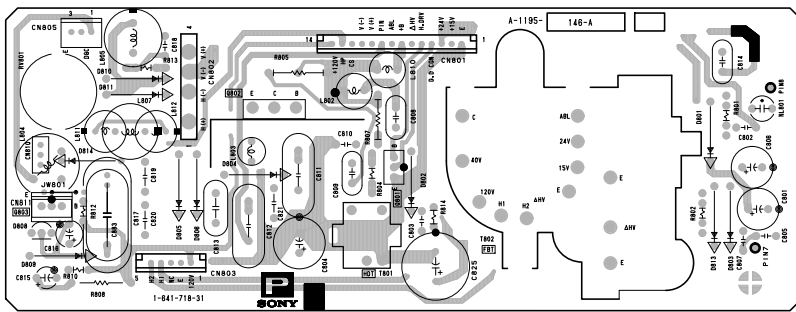

P -A SIDE-  
SUFFIX: -31

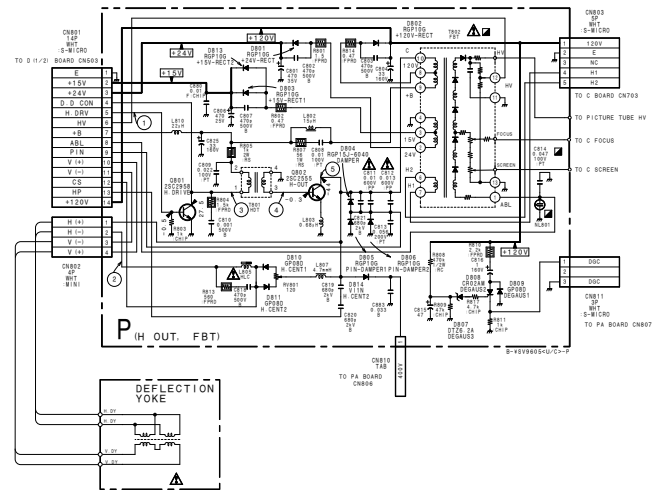

P -B SIDE-  
SUFFIX: -31

P BOARD WAVEFORMS

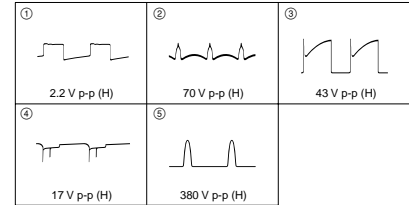

S MIC Chassis | A | B | C | D | 10-11 | E | 10-11 | F | G | H

**B B**

**B BOARD**

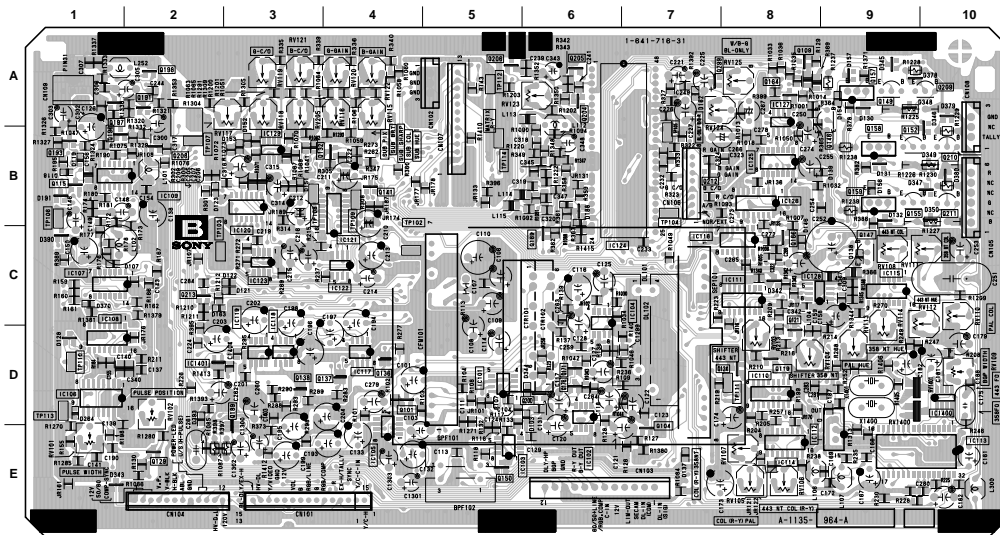

**B - A SIDE-  
SUFFIX: -31**

**B Board (A SIDE)**

IC501	B-1	D103	D-6
IC101	D-5	D107	C-2
IC102	E-6	D118	B-1
IC103	E-5	D119	B-1
IC104	C-7	D121	C-3
IC105	E-4	D122	C-3
IC106	D-1	D123	B-2
IC107	C-1	D128	D-1
IC108	C-1	D130	A-9
IC109	B-2	D131	B-9
IC110	D-8	D132	B-9
IC111	C-8	D137	E-7
IC112	E-8	D138	C-9
IC113	E-10	D139	B-9
IC114	E-8	D148	B-8
IC115	C-9	D151	B-3
IC117	4	D153	B-3
IC118	C-3	D154	A-9
IC118	C-7	D157	A-9
IC119	C-3	D158	B-9
IC120	C-3	D162	A-7
IC121	C-4	D163	C-2
IC122	C-4	D188	B-6
IC123	C-3	D191	B-1
IC124	C-6	D264	D-1
IC125	B-8	D342	C-8
IC127	A-8	D343	B-1
IC128	B-8	D344	D-6
IC128	C-8	D345	A-9
IC129	B-3	D346	A-10
IC1400	D-10	D347	B-9
IC1401	D-2	D348	A-10
IC1401	D-2	D349	B-10
Q101	D-4	D350	B-10
Q104	E-7	D370	C-1
Q109	A-8	D378	A-10
Q115	D-1	D379	A-10
Q119	D-8	D380	B-10
Q121	C-8	D390	C-1
Q124	D-8	D393	D-2
Q129	E-2		
Q132	B-3	RV101	B-1
Q136	D-4	RV102	D-2
Q137	D-4	RV103	D-8
Q138	D-3	RV104	D-9
Q141	B-4	RV105	E-8
Q147	C-9	RV106	E-8
Q148	B-9	RV107	C-9
Q149	A-9	RV108	C-9
Q150	A-5	RV109	D-10
Q152	B-9	RV110	C-10
Q155	B-9	RV111	C-9
Q157	A-9	RV112	C-10
Q158	B-9	RV113	C-9
Q159	B-9	RV114	C-9
Q164	A-8	RV115	A-4
Q166	C-8	RV116	A-4
Q169	C-6	RV117	B-2
Q171	D-6	RV118	A-3
Q176	D-6	RV119	A-3
Q180	D-1	RV120	A-3
Q191	A-2	RV121	A-3
Q193	B-1	RV122	A-4
Q196	B-1	RV123	A-5
Q197	A-1	RV124	B-7
Q198	A-2	RV125	A-8
Q200	D-6	RV205	A-3
Q204	A-6		
Q205	A-6	TP102	B-4
Q206	A-5	TP103	C-2
Q208	B-2	TP104	B-7
Q209	A-10	TP105	B-7
Q210	B-10	TP106	B-1
Q211	B-10	TP107	B-2
Q212	B-7	TP108	B-3
Q213	C-2	TP109	B-4
Q299	A-7	TP110	D-1
		TP111	D-8
		TP112	A-5
		TP113	D-1
		TP114	B-5

B B

B Board (B SIDE)

IC112	E-2	D101	D-5
IC124	C-4	D102	E-5
		D104	D-5
Q101	B-2	D105	E-5
Q102	E-7	D106	C-9
Q103	C-6	D108	C-10
Q105	D-6	D109	C-9
Q107	C-5	D110	D-10
Q108	D-5	D111	D-10
Q108	D-7	D112	B-10
Q112	C-9	D113	B-9
Q113	C-10	D115	D-9
Q114	C-10	D116	C-10
Q116	D-10	D117	C-10
Q117	D-2	D120	E-2
Q118	C-3	D125	A-7
Q119	A-2	D126	B-7
Q120	D-3	D127	D-8
Q122	D-3	D129	R-1
Q123	D-3	D133	A-4
Q125	E-2	D134	B-4
Q126	E-2	D136	C-2
Q127	E-3	D144	C-3
Q128	E-2	D145	C-3
Q130	D-3	D147	A-3
Q134	D-2	D148	A-2
Q135	B-5	D149	B-2
Q139	D-8	D150	C-2
Q140	D-2	D158	A-2
Q140	C-7	D159	B-2
Q142	B-7	D160	C-8
Q143	B-8	D161	C-8
Q144	A-5	D170	B-9
Q145	B-5	D171	D-9
Q146	A-2	D172	A-10
Q147	C-2	D180	C-10
Q148	A-2	D185	D-9
Q151	B-1	D187	E-9
Q152	B-2	D188	D-5
Q153	B-2	D280	B-6
Q154	B-1	D285	C-7
Q155	B-2	D341	B-10
Q156	B-8	D1380	C-8
Q157	A-2	D1381	C-8
Q159	C-2	D1382	C-8
Q160	A-2	D1400	D-1
Q165	C-3	D1401	D-9
Q167	B-3		
Q168	B-3	RV101	B-10
Q170	B-3	RV102	D-9
Q172	B-3	RV103	D-3
Q173	B-3	RV104	D-2
Q174	B-3	RV105	B-3
Q175	B-3	RV106	B-3
Q177	A-3	RV107	B-3
Q178	E-6	RV108	C-1
Q179	A-3	RV109	D-1
Q190	B-8	RV110	D-1
Q192	B-9	RV111	C-1
Q194	A-10	RV112	D-1
Q195	B-9	RV113	B-3
Q199	A-10	RV114	C-2
Q201	B-5	RV115	A-7
Q202	B-5	RV116	A-7
Q203	B-5	RV117	A-9
Q208	A-1	RV118	A-8
Q210	B-1	RV119	A-8
Q211	C-1	RV120	A-7
Q1401	D-1	RV121	A-7
		RV122	A-7
		RV123	A-5
		RV124	A-3
		RV125	A-3
		RV205	A-7

B BOARD

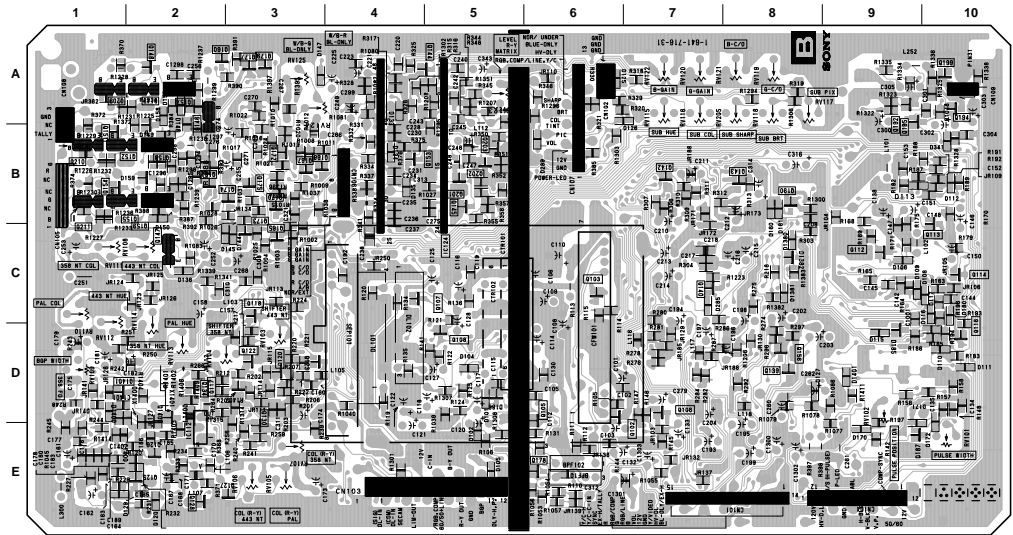

B - B SIDE-  
SUFFIX: -31

B (1/3) B (1/3)

B MOUNT (1/3) VOLTAGES

IC102	IC		
	PAL	SECAM	NTSC
1	6.7	6.7	6.7
2	7.1	0	0
3	0	0	0
4	0	0	0
5	6.6	6.6	6.6
6	12VA	12VA	12VA
7	6	6	6
8	GND	GND	GND
9	9.4	0	0
10	11.5	0	0
11	9.9	0	0
12	11.5	0	0
13	11.5	11.5	11.5
14	11.5	0	0
15	0	2.3	2.3
16	GND	GND	GND
17	GND	GND	GND
18	GND	GND	GND
19	11.5	11.5	11.5
20	11.5	0	0
21	11.5	0	0
22	11.5	0	0
23	11.5	0	0
24	11.5	0	0
25	11.5	0	0
26	11.5	0	0
27	11.5	0	0
28	11.5	0	0
29	11.5	0	0
30	11.5	0	0
31	1.4	1.4	1.4
32	NC	NC	NC

CROSS-REFERENCE OF \* MARKS ON B (1/3) BOARD

IC114	PAL			SECAM			NTSC				
	1	0	2.6	2.6	0	2.6	2.6	0	2.6	2.6	
2	0	2.6	2.6	0	2.6	2.6	0	2.6	2.6		
3	2	2.6	2.6	2	2.6	2.6	2	2.6	2.6		
4	NC	NC	NC	4	NC	NC	4	NC	NC		
5	NC	NC	NC	5	NC	NC	5	NC	NC		
6	GND	GND	GND	6	GND	GND	6	GND	GND		
7	GND	GND	GND	7	GND	GND	7	GND	GND		
8	GND	GND	GND	8	GND	GND	8	GND	GND		
9	11.5	0	0	9	11.5	0	0	9	11.5	0	0
10	11.5	0	0	10	11.5	0	0	10	11.5	0	0
11	11.5	3.7	3.7	11	11.5	3.7	3.7	11	11.5	3.7	3.7
12	0.8	3.9	3.9	12	0.8	3.9	3.9	12	0.8	3.9	3.9
13	1.7	3.9	3.9	13	1.7	3.9	3.9	13	1.7	3.9	3.9
14	NC	NC	NC	14	NC	NC	NC	14	NC	NC	NC
15	0.8	3.6	3.6	15	0.8	3.6	3.6	15	0.8	3.6	3.6
16	12VA	12VA	12VA	16	12VA	12VA	12VA	16	12VA	12VA	12VA
17	0	0	0	17	0	0	0	17	0	0	0
18	0	0	0	18	0	0	0	18	0	0	0
19	0.4	0.4	0.4	19	0.4	0.4	0.4	19	0.4	0.4	0.4
20	0.4	0.4	0.4	20	0.4	0.4	0.4	20	0.4	0.4	0.4
21	NC	NC	NC	21	NC	NC	NC	21	NC	NC	NC
22	NC	NC	NC	22	NC	NC	NC	22	NC	NC	NC
23	GND	GND	GND	23	GND	GND	GND	23	GND	GND	GND
24	GND	GND	GND	24	GND	GND	GND	24	GND	GND	GND
25	GND	GND	GND	25	GND	GND	GND	25	GND	GND	GND
26	11.5	11.5	11.5	26	11.5	11.5	11.5	26	11.5	11.5	11.5
27	11.5	11.5	11.5	27	11.5	11.5	11.5	27	11.5	11.5	11.5
28	11.5	11.5	11.5	28	11.5	11.5	11.5	28	11.5	11.5	11.5
29	11.5	11.5	11.5	29	11.5	11.5	11.5	29	11.5	11.5	11.5
30	11.5	11.5	11.5	30	11.5	11.5	11.5	30	11.5	11.5	11.5
31	11.5	11.5	11.5	31	11.5	11.5	11.5	31	11.5	11.5	11.5
32	11.5	11.5	11.5	32	11.5	11.5	11.5	32	11.5	11.5	11.5

\* All voltages are in V (volt).  
 \* NC: No connection.  
 \* \* mark: measurement impossible.

PVM-8042Q (U/C)		
PVM-8045Q (U/C)		
PVM-9042QM (AEP)		
PVM-9042QM (AEP)		
PVM-9045QM (AEP)		
PVM-9045QM (AUS)		PVM-9045PM(BRZ)
BPF102	1-236-364-11	1-236-363-11
C104	0.01 .CHIP	NOT USED
C105	0.01 .CHIP	NOT USED
C115	0.01 .CHIP	NOT USED
C134	0.01 .CHIP	NOT USED
C157	12P .CHIP	NOT USED
CTR101	1-236-366-11	1-809-369-11
CTR102	1-236-365-11	NOT USED
D102	NOT USED	MA111
D105	MA111	NOT USED
D186	MA151WK	NOT USED
D344	DTZ-TT11-6.2A	NOT USED
IC101	MM1111XFBE	NOT USED
JR256	NOT USED	SHORT 0
L103	4.7µH	NOT USED
Q118	2SC2412K	NOT USED
Q119	2SB709A	NOT USED
Q200	DTA114EK	NOT USED
R107	27K .CHIP	NOT USED
R123	100 .CHIP	NOT USED
R209	560 .CHIP	NOT USED
R210	220 .CHIP	NOT USED
R213	560 .CHIP	NOT USED
R253	150K .CHIP	NOT USED
R1043	2.2K .CHIP	NOT USED
R1044	3.3K .CHIP	NOT USED
R1055	NOT USED	100K .CHIP
R1313	150K .CHIP	120K .CHIP
R1405	5.6K .CHIP	NOT USED
R1406	5.6K .CHIP	NOT USED
R1408	5.6K .CHIP	1K .CHIP
R1409	5.6K .CHIP	1K .CHIP
RV103	220	NOT USED
RV106	1K	NOT USED
RV108	10K	NOT USED
RV112	47K	NOT USED
X1401	1-577-259-11	1-527-523-00
	OSCILLATOR, CRYSTAL	OSCILLATOR, CRYSTAL

B (1/3) BOARD WAVEFORMS

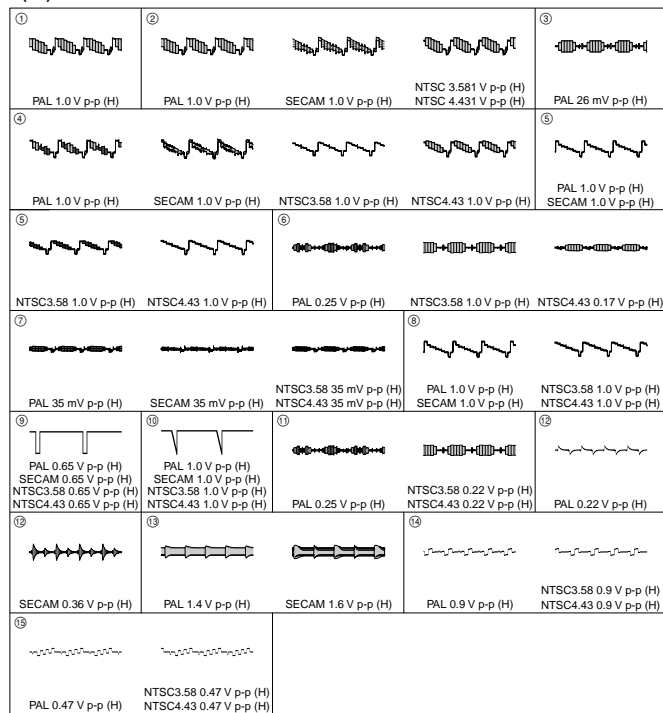

A | B | C | D | E | F | G | H

B (1/3) BOARD

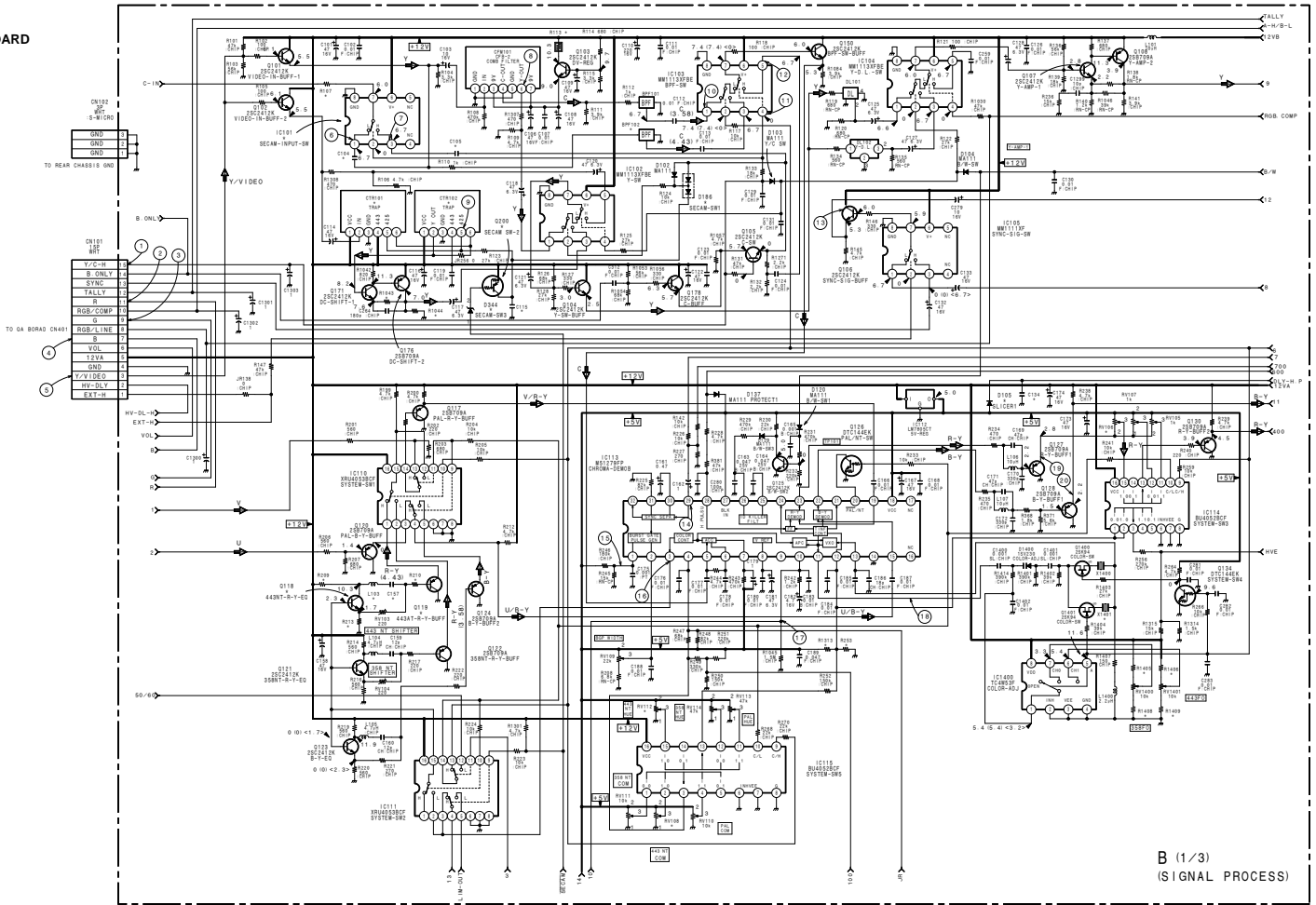

B (2/3) BOARD WAVEFORMS

B MOUNT (2/3) VOLTAGES

IC	PAL			SECAM			NTSC		
	1	2	3	4	5	6	7	8	9
IC106	1	0	0	0	0	0	0	0	0
	2	0.2	0.2	0.2	0.2	0.2	0.2	0.2	0.2
	3	12VB	12VB	12VB	12VB	12VB	12VB	12VB	12VB
	4	1.8	1.8	1.8	1.8	1.8	1.8	1.8	1.8
	5	12VB	12VB	12VB	12VB	12VB	12VB	12VB	12VB
	6	12	12	12	12	12	12	12	12
	7	NC	NC	NC	NC	NC	NC	NC	NC
	8	GND	GND	GND	GND	GND	GND	GND	GND
	9	10.2	10.2	10.2	10.2	10.2	10.2	10.2	10.2
	10	1.2	1.2	1.2	1.2	1.2	1.2	1.2	1.2
	11	12	12	12	12	12	12	12	12
	12	1.7	1.7	1.7	1.7	1.7	1.7	1.7	1.7
	13	12VB	12VB	12VB	12VB	12VB	12VB	12VB	12VB
	14	9.8	0	0	0	0	0	0	0
	15	GND	GND	GND	GND	GND	GND	GND	GND
	16	12VB	12VB	12VB	12VB	12VB	12VB	12VB	12VB
IC108	1	0.3	0.3	0.3	0.3	0.3	0.3	0.3	
	2	GND	GND	GND	GND	GND	GND	GND	
	3	GND	GND	GND	GND	GND	GND	GND	
	4	0.4	0.4	0.4	0.4	0.4	0.4	0.4	
	5	0.4	0.4	0.4	0.4	0.4	0.4	0.4	
	6	GND	GND	GND	GND	GND	GND	GND	
	7	GND	GND	GND	GND	GND	GND	GND	
	8	GND	GND	GND	GND	GND	GND	GND	
IC109	9	8.2	8.2	8.2	8.2	8.2	8.2	8.2	
	10	5.5	6	6	6	6	6	6	
	11	9.8	9.8	9.8	9.8	9.8	9.8	9.8	
	12	0.5	0.5	0.5	0.5	0.5	0.5	0.5	
	13	0.3	0.3	0.3	0.3	0.3	0.3	0.3	
	14	0.3	0.3	0.3	0.3	0.3	0.3	0.3	
	15	0.3	0.3	0.3	0.3	0.3	0.3	0.3	
	16	12VB	12VB	12VB	12VB	12VB	12VB	12VB	
	1	GND	GND	GND	GND	GND	GND	GND	
	2	11.2	11.2	11.2	11.2	11.2	11.2	11.2	
	3	11.6	11.6	11.6	11.6	11.6	11.6	11.6	
	4	11.9	11.9	11.9	11.9	11.9	11.9	11.9	
	5	11.3	11.3	11.3	11.3	11.3	11.3	11.3	
	6	0.6	0	0	0	0	0	0	
	7	0	0	0	0	0	0	0	
	8	GND	GND	GND	GND	GND	GND	GND	
9	GND	GND	GND	GND	GND	GND	GND		
10	0.7	0.7	0.7	0.7	0.7	0.7	0.7		
11	0.4	0.4	0.4	0.4	0.4	0.4	0.4		
12	10.5	10.5	10.5	10.5	10.5	10.5	10.5		
13	9.1	9.1	9.1	9.1	9.1	9.1	9.1		
14	12VB	12VB	12VB	12VB	12VB	12VB	12VB		
IC118	1	5.4	0	0	0	0	0	0	
	2	2.8	0	2.8	2.8	2.8	2.8	2.8	
	3	0	5.4	5.4	5.4	5.4	5.4	5.4	
	4	0	0	0	0	0	0	0	
	5	5.4	0	0	0	0	0	0	
	6	12VB	12VB	12VB	12VB	12VB	12VB	12VB	
	7	5.7	5.7	5.7	5.7	5.7	5.7	5.7	
	8	GND	GND	GND	GND	GND	GND	GND	
IC120	1	5.1	5.1	5.1	5.1	5.1	5.1	5.1	
	2	5.1	5.1	5.1	5.1	5.1	5.1	5.1	
	3	5.1	5.1	5.1	5.1	5.1	5.1	5.1	
	4	5.1	5.1	5.1	5.1	5.1	5.1	5.1	
	5	0.4	0.4	0.4	0.4	0.4	0.4	0.4	
	6	8.3	8.3	8.3	8.3	8.3	8.3	8.3	
	7	GND	GND	GND	GND	GND	GND	GND	
	8	12VB	2VB	2VB	2VB	2VB	2VB	2VB	
	9	12	12	12	12	12	12	12	
	10	4.8	4.8	4.8	4.8	4.8	4.8	4.8	
	11	5.1	5.1	5.1	5.1	5.1	5.1	5.1	
	12	0.5	0.5	0.5	0.5	0.5	0.5	0.5	
	13	0.4	0.4	0.4	0.4	0.4	0.4	0.4	
	14	12VB	12VB	12VB	12VB	12VB	12VB	12VB	

IC	PAL			SECAM			NTSC		
	1	2	3	4	5	6	7	8	9
IC121	1	0	5.1	5.1	5.1	5.1	5.1	5.1	5.1
	2	5.1	5.1	5.1	5.1	5.1	5.1	5.1	5.1
	3	0	0	0	0	0	0	0	0
	4	5.1	0	0	0	0	0	0	0
	5	5.1	0	0	0	0	0	0	0
	6	GND	GND	GND	GND	GND	GND	GND	GND
	7	GND	GND	GND	GND	GND	GND	GND	GND
	8	GND	GND	GND	GND	GND	GND	GND	GND
	9	2	2	2	2	2	2	2	2
	10	2	2	2	2	2	2	2	2
	11	2	2	2	2	2	2	2	2
	12	5.1	5.1	5.1	5.1	5.1	5.1	5.1	5.1
	13	0	4.8	4.8	4.8	4.8	4.8	4.8	4.8
	14	5.1	5.1	5.1	5.1	5.1	5.1	5.1	5.1
	15	5.1	5.1	5.1	5.1	5.1	5.1	5.1	5.1
	16	12VB	12VB	12VB	12VB	12VB	12VB	12VB	12VB
IC122	1	4.8	4.8	4.8	4.8	4.8	4.8	4.8	
	2	4.8	4.8	4.8	4.8	4.8	4.8	4.8	
	3	4.8	4.8	4.8	4.8	4.8	4.8	4.8	
	4	GND	GND	GND	GND	GND	GND	GND	
	5	5.1	5.1	5.1	5.1	5.1	5.1	5.1	
	6	5.1	5.1	5.1	5.1	5.1	5.1	5.1	
	7	5.1	5.1	5.1	5.1	5.1	5.1	5.1	
	8	12VB	12VB	12VB	12VB	12VB	12VB	12VB	
IC123	1	0	0.6	0.6	0.6	0.6	0.6	0.6	
	2	2.5	2.5	2.5	2.5	2.5	2.5	2.5	
	3	1.7	1.7	1.7	1.7	1.7	1.7	1.7	
	4	GND	GND	GND	GND	GND	GND	GND	
	5	5.1	5.1	5.1	5.1	5.1	5.1	5.1	
	6	5.1	5.1	5.1	5.1	5.1	5.1	5.1	
	7	5.1	5.1	5.1	5.1	5.1	5.1	5.1	
	8	12VB	12VB	12VB	12VB	12VB	12VB	12VB	
	1	3	3	3	3	3	3	3	
	2	3	3	3	3	3	3	3	
	3	0	2.9	2.9	2.9	2.9	2.9	2.9	
	4	GND	GND	GND	GND	GND	GND	GND	
	5	5.3	4.6	4.6	4.6	4.6	4.6	4.6	
	6	5	5	5	5	5	5	5	
	7	10.4	0	0	0	0	0	0	
	8	12VB	12VB	12VB	12VB	12VB	12VB	12VB	
<b>TRANSISTOR</b>									
Q136	1	12VB	12VB	12VB	12VB	12VB	12VB	12VB	
	2	5.7	5.7	5.7	5.7	5.7	5.7	5.7	
	3	5.1	5.1	5.1	5.1	5.1	5.1	5.1	
	4	10.5	10.5	10.5	10.5	10.5	10.5	10.5	
	5	5.7	5.7	5.7	5.7	5.7	5.7	5.7	
	6	5.1	5.1	5.1	5.1	5.1	5.1	5.1	
	7	5.7	5.7	5.7	5.7	5.7	5.7	5.7	
	8	5.1	5.1	5.1	5.1	5.1	5.1	5.1	
Q137	1	12VB	12VB	12VB	12VB	12VB	12VB	12VB	
	2	5.7	5.7	5.7	5.7	5.7	5.7	5.7	
	3	5.1	5.1	5.1	5.1	5.1	5.1	5.1	
	4	10.5	10.5	10.5	10.5	10.5	10.5	10.5	
	5	5.7	5.7	5.7	5.7	5.7	5.7	5.7	
	6	5.1	5.1	5.1	5.1	5.1	5.1	5.1	
	7	5.7	5.7	5.7	5.7	5.7	5.7	5.7	
	8	5.1	5.1	5.1	5.1	5.1	5.1	5.1	
	9	10.5	10.5	10.5	10.5	10.5	10.5	10.5	
	10	5.7	5.7	5.7	5.7	5.7	5.7	5.7	
	11	5.1	5.1	5.1	5.1	5.1	5.1	5.1	
	12	5.7	5.7	5.7	5.7	5.7	5.7	5.7	
	13	5.1	5.1	5.1	5.1	5.1	5.1	5.1	
	14	10.5	10.5	10.5	10.5	10.5	10.5	10.5	
Q138	1	12VB	12VB	12VB	12VB	12VB	12VB	12VB	
	2	5.7	5.7	5.7	5.7	5.7	5.7	5.7	
	3	5.1	5.1	5.1	5.1	5.1	5.1	5.1	
	4	10.5	10.5	10.5	10.5	10.5	10.5	10.5	
	5	5.7	5.7	5.7	5.7	5.7	5.7	5.7	
Q132	B	6	6	6	6	6	6	6	
	C	1.7	1.7	1.7	1.7	1.7	1.7	1.7	
	9	12	12	12	12	12	12	12	
	10	4.8	4.8	4.8	4.8	4.8	4.8	4.8	
	11	5.1	5.1	5.1	5.1	5.1	5.1	5.1	

• All voltages are in V (volt).  
• NC: No connection.

CROSS-REFERENCE OF \* MARKS ON B (2/3) BOARD

PVM-8042Q (U/C)	PVM-8045Q (U/C)	PVM-9042QM (AEP)	PVM-9042QM (AUS)	PVM-9045QM (AEP)	PVM-9045QM (AUS)	PVM-9045PM(BRZ)
C135	88P	CHIP	NOT USED	NOT USED	NOT USED	NOT USED
C190	150P	CHIP	NOT USED	NOT USED	NOT USED	NOT USED
C193	47 16V	CHIP	NOT USED	NOT USED	NOT USED	NOT USED
C197	47 16V	CHIP	NOT USED	NOT USED	NOT USED	NOT USED
C308	0.1 25V	CHIP	NOT USED	NOT USED	NOT USED	NOT USED
C309	0.1 25V	CHIP	NOT USED	NOT USED	NOT USED	NOT USED
C310	0.1 25V	CHIP	NOT USED	NOT USED	NOT USED	NOT USED
CN103	B to B 12P	NOT USED	NOT USED	NOT USED	NOT USED	NOT USED
D108	MA111	NOT USED	NOT USED	NOT USED	NOT USED	NOT USED
D116	NOT USED	MA111	NOT USED	NOT USED	NOT USED	NOT USED
D121	MA111	NOT USED	NOT USED	NOT USED	NOT USED	NOT USED
D185	MA151WA	NOT USED	NOT USED	NOT USED	NOT USED	NOT USED
D342	MA151WA	NOT USED	NOT USED	NOT USED	NOT USED	NOT USED
D390	MA157	NOT USED	NOT USED	NOT USED	NOT USED	NOT USED
IC128	LM358DR	NOT USED	NOT USED	NOT USED	NOT USED	NOT USED
JR113	NOT USED	SHORT 0	NOT USED	NOT USED	NOT USED	NOT USED
Q129	DTC144EK	NOT USED	NOT USED	NOT USED	NOT USED	NOT USED
R130	100K	CHIP	NOT USED	NOT USED	NOT USED	NOT USED
R148	6.8K	CHIP	NOT USED	NOT USED	NOT USED	NOT USED
R161	47K	CHIP	NOT USED	NOT USED	NOT USED	NOT USED
R182	20K	RN-CP	22K	CHIP-CP	NOT USED	NOT USED
R389	47K	CHIP	NOT USED	NOT USED	NOT USED	NOT USED
R1040	100	CHIP	NOT USED	NOT USED	NOT USED	NOT USED
R1280	330K	CHIP	NOT USED	NOT USED	NOT USED	NOT USED
R1285	NOT USED	2.2K	CHIP	NOT USED	NOT USED	NOT USED
R1339	100K	CHIP	NOT USED	NOT USED	NOT USED	NOT USED
R1340	100K	CHIP	NOT USED	NOT USED	NOT USED	NOT USED
R1341	390K	CHIP	NOT USED	NOT USED	NOT USED	NOT USED
R13						





**B MOUNT (3/3) VOLTAGES**

IC116	IC		
	PAL	SECAM	NTSC
1	1.8	1.8	1.8
2	1.1	1.1	1.1
3	1.7	1.5	1.5
4	1	0	0
5	1.6	1.8	1.8
6	GND	GND	GND
7	GND	GND	GND
8	NC	NC	NC
9	NC	NC	NC
10	1.8	1.8	1.8
11	0.9	0.9	0.9
12	1.8	1.8	1.8
13	1.8	1.8	1.8
14	12VA	12VA	12VA
1	4.3	4.3	4.3
2	4.3	4.3	4.3
3	5.2	5.2	5.2
4	GND	GND	GND
5	8.7	8.7	8.7
6	2.9	2.9	2.9
7	4.8	7.1	7.1
8	3.1	3.1	3.1
9	GND	GND	GND
10	5.6	5.6	5.6
11	5.7	5.7	5.7
12	5.6	5.6	5.6
13	GND	GND	GND
14	GND	GND	GND
15	GND	GND	GND
16	0	0	0
17	0	0	0
18	0	0	0
19	GND	GND	GND
20	1.3	1.3	1.3
21	0	0	0
22	0.4	0.6	0.6
23	0.2	0.2	0.2
24	0.2	0.2	0.2
25	4.2	4.2	4.2
26	4.7	4.7	4.7
27	4.5	4.5	4.5
28	6.1	6.8	6.8
29	GND	GND	GND
30	1.7	1.5	1.5
31	12VA	12VA	12VA
32	5.9	5.9	5.9
33	4.4	4.4	4.4
34	6	6.3	6.3
35	GND	GND	GND
36	1.8	1.5	1.5
37	12VA	12VA	12VA
38	6	6	6
39	6.2	7.5	7.5
40	GND	GND	GND
41	1.7	1.5	1.5
42	12VA	12VA	12VA
43	12VA	12VA	12VA
44	6.2	6.2	6.2
45	0	0	0
46	4.7	5.1	5.1
47	6.4	6.4	6.4
48	6.4	6.4	6.4

IC125	PAL SECAM NTSC		
	1	1.8	1.8
2	1.8	1.8	1.8
3	1.8	1.8	1.8
4	1.8	1.8	1.8
5	0.7	0.7	0.7
6	0.7	0.7	0.7
7	GND	GND	GND
8	1.7	1.7	1.7
9	1.7	1.7	1.7
10	1.7	1.7	1.7
11	1.7	1.7	1.7
12	0.7	0.7	0.7
13	0.7	0.7	0.7
14	12VA	12VA	12VA
1	1.8	1.8	1.8
2	1.6	1.6	1.6
3	NC	NC	NC
4	1.6	1.6	1.6
5	1.6	1.6	1.6
6	GND	GND	GND
7	GND	GND	GND
8	GND	GND	GND
9	GND	GND	GND
10	10.7	10.7	10.7
11	10.7	10.7	10.7
12	1.8	1.8	1.8
13	0	1.7	1.7
14	1.8	1.8	1.8
15	1.8	1.8	1.8
16	12VA	12VA	12VA
1	6.1	5.8	5.8
2	1.7	1.7	1.7
3	1.7	1.7	1.7
4	GND	GND	GND
5	1.7	1.7	1.7
6	1.7	1.7	1.7
7	6.1	5.9	5.9
8	10.2	10.2	10.2

**TRANSISTOR**

Q109	PAL SECAM NTSC			
	B	2.5	2.5	2.5
C	0.5	1.1	1.1	
E	GND	GND	GND	
Q146 <td>B</td> <td>0.2</td> <td>0.2</td> <td>0.2</td>	B	0.2	0.2	0.2
C	112	112	112	
E	GND	GND	GND	
Q147 <td>B</td> <td>118.3</td> <td>116.9</td> <td>116.9</td>	B	118.3	116.9	116.9
E	112.2	112.4	112.4	
C	120.3	119.7	119.7	
Q148 <td>B</td> <td>82</td> <td>84.4</td> <td>84.4</td>	B	82	84.4	84.4
C	87.5	91.3	91.3	
E	89.2	94.4	94.4	
Q149 <td>B</td> <td>88.5</td> <td>89.5</td> <td>89.5</td>	B	88.5	89.5	89.5
C	2.9	2.9	2.9	
E	93.2	93.2	93.2	
Q151 <td>B</td> <td>83.5</td> <td>85.2</td> <td>85.2</td>	B	83.5	85.2	85.2
C	116.2	117.1	117.1	
E	94.5	94.5	94.5	
Q152 <td>B</td> <td>98.9</td> <td>99.8</td> <td>99.8</td>	B	98.9	99.8	99.8
C	3	2.7	2.7	
E	92.3	93.4	93.4	
Q154 <td>B</td> <td>90</td> <td>92.3</td> <td>92.3</td>	B	90	92.3	92.3
C	99.5	99.2	99.2	
E	101.2	105	105	
Q155 <td>B</td> <td>98.9</td> <td>99.7</td> <td>99.7</td>	B	98.9	99.7	99.7
C	3	2.5	2.5	
E	94.5	95.8	95.8	

Q165	PAL SECAM NTSC			
	B	1.1	0.8	0.8
C	GND	GND	GND	
E	1.8	1.5	1.5	
Q166 <td>B</td> <td>1.1</td> <td>0.8</td> <td>0.8</td>	B	1.1	0.8	0.8
C	GND	GND	GND	
E	1.8	1.5	1.5	
Q167 <td>B</td> <td>1.1</td> <td>0.7</td> <td>0.7</td>	B	1.1	0.7	0.7
C	GND	GND	GND	
E	1.7	1.4	1.4	
Q168 <td>B</td> <td>1.6</td> <td>1.2</td> <td>1.2</td>	B	1.6	1.2	1.2
C	GND	GND	GND	
E	2.3	1.8	1.8	
Q170 <td>B</td> <td>2.4</td> <td>2.1</td> <td>2.1</td>	B	2.4	2.1	2.1
C	12VA	12VA	12VA	
E	1.7	1.5	1.5	
Q172 <td>B</td> <td>2.4</td> <td>2.1</td> <td>2.1</td>	B	2.4	2.1	2.1
C	12VA	12VA	12VA	
E	1.7	1.5	1.5	
Q173 <td>B</td> <td>1.8</td> <td>1.8</td> <td>1.8</td>	B	1.8	1.8	1.8
C	GND	GND	GND	
E	2.3	2.3	2.3	
Q157 <td>B</td> <td>2.3</td> <td>2.3</td> <td>2.3</td>	B	2.3	2.3	2.3
C	89	89	89	
E	1.7	1.8	1.8	
Q158 <td>B</td> <td>4</td> <td>3.3</td> <td>3.3</td>	B	4	3.3	3.3
C	98.9	99.8	99.8	
E	1.8	1.5	1.5	
Q159 <td>B</td> <td>2.3</td> <td>1.9</td> <td>1.9</td>	B	2.3	1.9	1.9
C	98.9	99.7	99.7	
E	1.8	1.4	1.4	
Q161 <td>B</td> <td>0</td> <td>0</td> <td>0</td>	B	0	0	0
C	0.5	0.5	0.5	
E	GND	GND	GND	
Q189 <td>B</td> <td>4.6</td> <td>5.1</td> <td>5.1</td>	B	4.6	5.1	5.1
C	2.7	2.7	2.7	
E	3.4	3.3	3.3	
C	4	6.8	6.8	
E	0.6	0.6	0.6	
C	6	4	3.3	3.3
E	2	2	2	
Q201 <td>B</td> <td>2</td> <td>2</td> <td>2</td>	B	2	2	2
C	GND	GND	GND	
E	2.6	2.6	2.6	
Q202 <td>B</td> <td>2</td> <td>2</td> <td>2</td>	B	2	2	2
C	GND	GND	GND	
E	2.6	2.6	2.6	
Q203 <td>B</td> <td>2</td> <td>2</td> <td>2</td>	B	2	2	2
C	GND	GND	GND	
E	2.6	2.6	2.6	
Q204 <td>B</td> <td>2</td> <td>2</td> <td>2</td>	B	2	2	2
C	GND	GND	GND	
E	2.6	2.6	2.6	
Q205 <td>B</td> <td>1.7</td> <td>1.7</td> <td>1.7</td>	B	1.7	1.7	1.7
C	GND	GND	GND	
E	2.3	2.3	2.3	
Q206 <td>B</td> <td>1.2</td> <td>1.2</td> <td>1.2</td>	B	1.2	1.2	1.2
C	GND	GND	GND	
E	1.9	1.9	1.9	
Q210 <td>B</td> <td>100</td> <td>100.5</td> <td>100.5</td>	B	100	100.5	100.5
C	116.2	116.7	116.7	
E	94.5	95.5	95.5	
Q211 <td>B</td> <td>100</td> <td>100.5</td> <td>100.5</td>	B	100	100.5	100.5
C	116.4	116.7	116.7	
E	96.5	95.5	95.5	
Q212 <td>G</td> <td>1.4</td> <td>1.4</td> <td>1.4</td>	G	1.4	1.4	1.4
D	1	1	1	
S	1	1	1	

• All voltages are in V (volt).  
• NC: No connection.

**CROSS-REFERENCE OF \* MARKS ON B (3/3) BOARD**

PVM-8042Q (U/C)
PVM-8045Q (U/C)
PVM-9042QM (AEP)
PVM-9042QM (AUS)
PVM-9045QM (AEP)
PVM-9045QM (AUS)
PVM-9045PM(BRZ)
TP114 NOT USED
1-535-877-22 CHIP CHECKER

**B (3/3) BOARD WAVEFORMS**

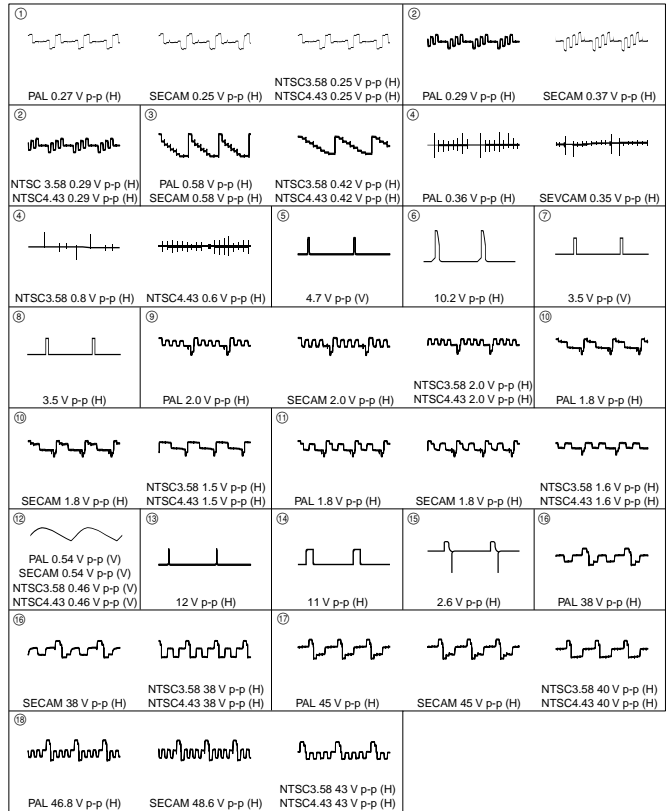

B (3/3) B (3/3)

B (3/3) BOARD

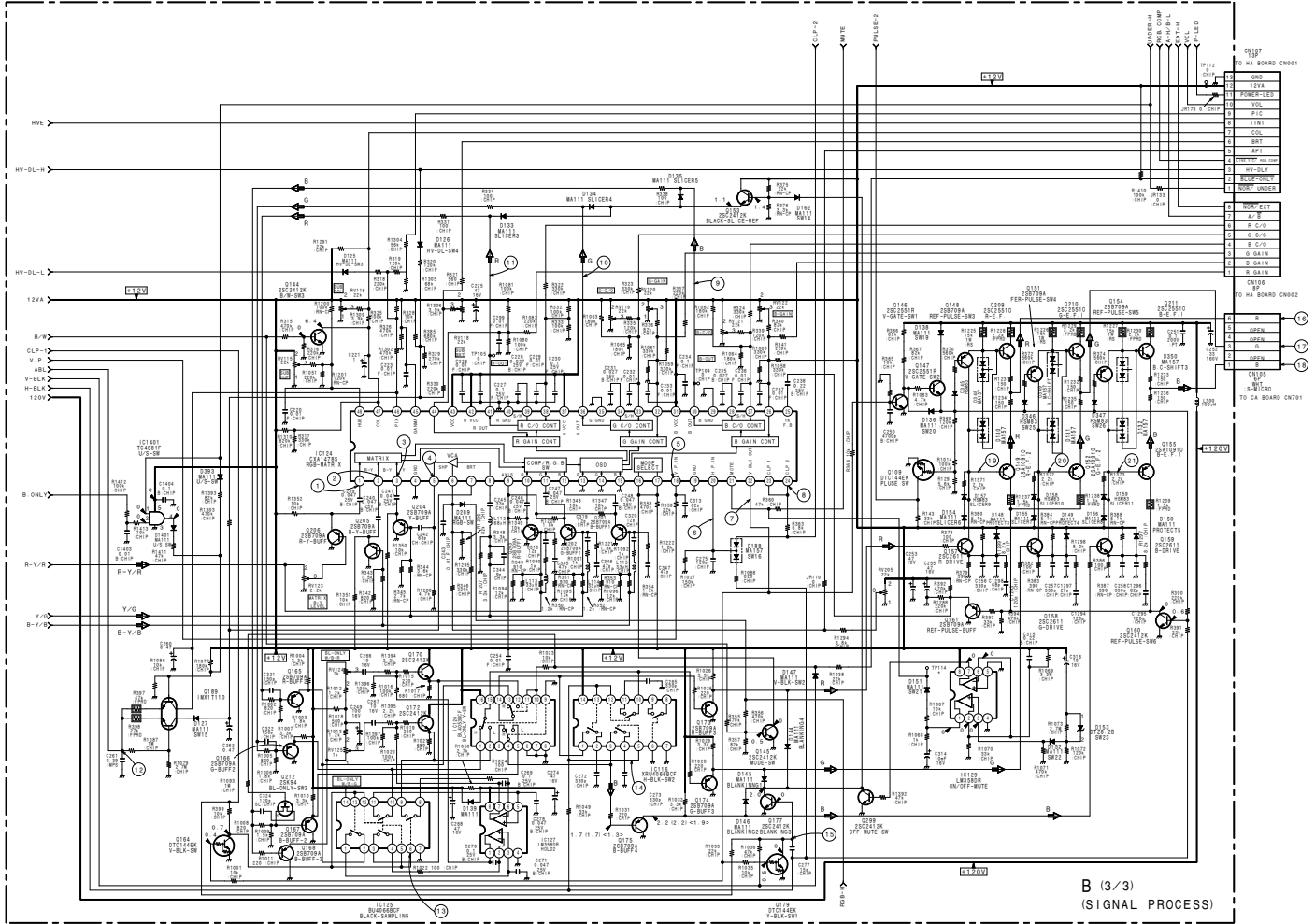

S/MIC Chassis  
A B C D E F G H  
10-19 10-19  
B (3/3) (SIGNAL PROCESS)  
B-1009065-10-C-3



HA, PA HA, PA

HA BOARD

HA BOARD

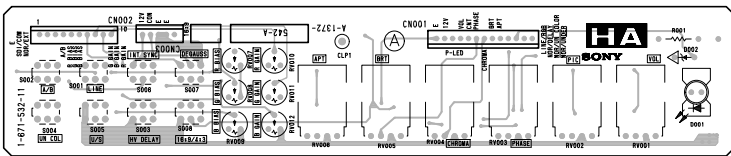

HA -A SIDE-  
SUFFIX: -11

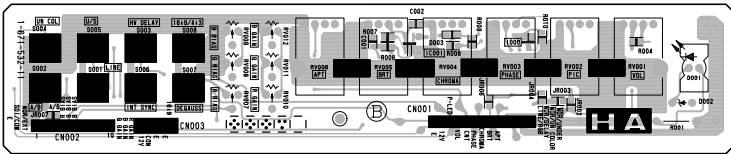

HA -B SIDE-  
SUFFIX: -11

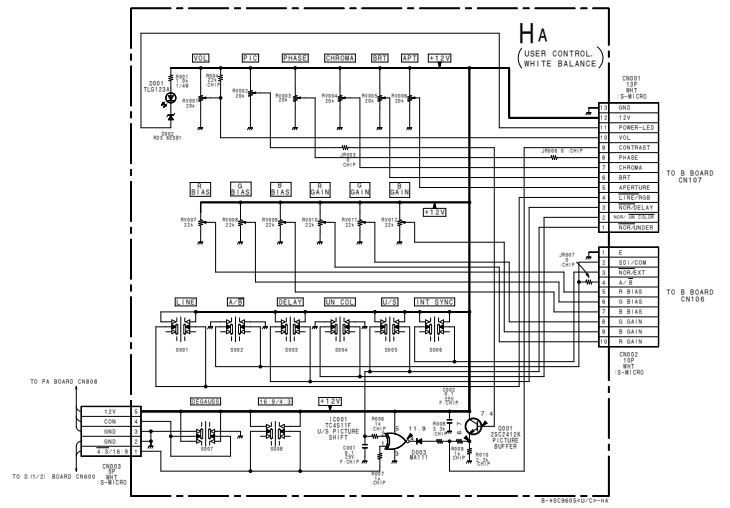

PA BOARD

PA BOARD

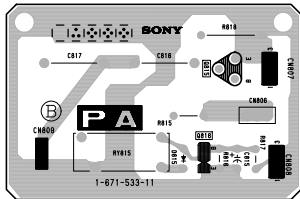

PA -B SIDE-  
SUFFIX: -11

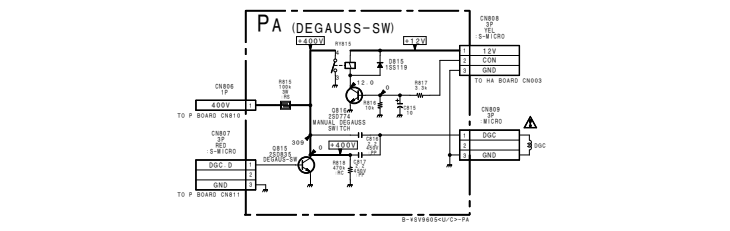

S MIC Chassis

10-21

10-21

A | B | C | D | E | F | G | H

CA, X CA, X

CA BOARD

X BOARD

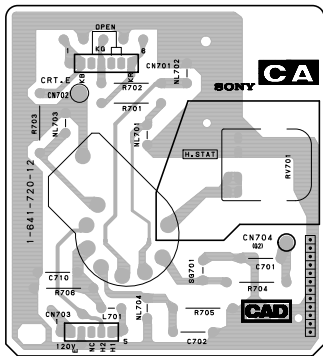

X - B SIDE-  
SUFFIX: -12

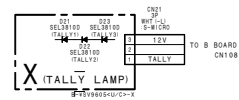

CA - B SIDE-  
SUFFIX: -12

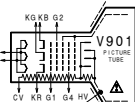

A32JW108X (PWB-94420 SU/C) PWB-94420M (AEPI)  
T862 HV  
W20JW108X (PWB-94420 SU/C) PWB-94420M (AUS) PWB-94420M (AEPI)

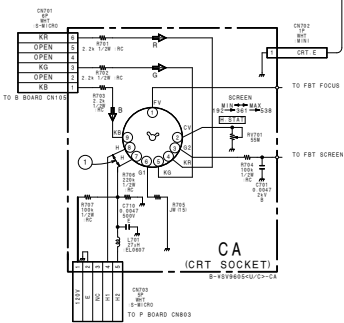

P BOARD WAVEFORMS

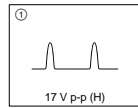

A | B | C | D | E | F | G | H

10-22

10-22

S MIC Chassis

The material contained in this manual consists of information that is the property of Sony Corporation and is intended solely for use by the purchasers of the equipment described in this manual.

Sony Corporation expressly prohibits the duplication of any portion of this manual or the use thereof for any purpose other than the operation or maintenance of the equipment described in this manual without the express written permission of Sony Corporation.

