

SERVICE MANUAL

<u>MODEL</u>	<u>DEST.</u>	<u>CHASSIS NO.</u>	<u>MODEL</u>	<u>DEST.</u>	<u>CHASSIS NO.</u>
<i>PVM-14M2MDU</i>	<i>US Canadian</i>	<i>SCC-N59B-A</i>	<i>PVM-20M2MDU</i>	<i>US Canadian</i>	<i>SCC-N59A-A</i>
<i>PVM-14M2MDE</i>	<i>AEP</i>	<i>SCC-N33F-A</i>	<i>PVM-20M2MDE</i>	<i>AEP</i>	<i>SCC-N33E-A</i>
<i>PVM-14M2MDA</i>	<i>Australian</i>	<i>SCC-N17E-A</i>	<i>PVM-20M2MDA</i>	<i>Australian</i>	<i>SCC-N17D-A</i>

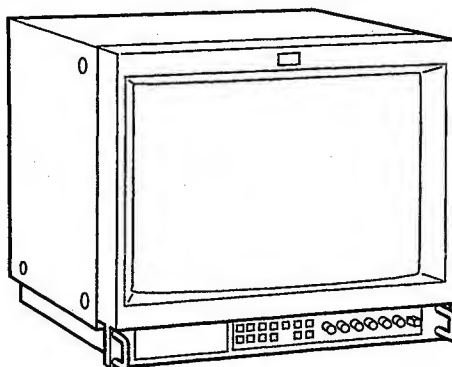

TRINITRON® COLOR VIDEO MONITOR

SONY®

SPECIFICATIONS

Video signal

For PVM-14M2MDU/14M2MDE/14M2MDA/ 20M2MDU/20M2MDE/20M2MDA:

Color system	NTSC, PAL
Resolution	600 TV lines
Aperture correction	0 dB to +6 dB
Frequency response	
LINE	10 MHz \pm 3 dB (Y signal)
RGB	10 MHz \pm 3 dB
Synchronization	AFC time constant 1.0 msec.

Picture performance

For PVM-14M2MDU/14M2MDE/14M2MDA:

Normal scan	7 % over scan of CRT effective screen area
Under scan	5 % underscan of CRT effective screen area
Over scan	20 % over scan of CRT effective screen area
H. linearity	Less than 4.0 % (typical)
V. linearity	Less than 4.0 % (typical)
Convergence	
Central area:	Less than 0.4 mm (typical)
Peripheral area:	Less than 0.5 mm (typical)
Raster size stability	H: 1.0%, V: 1.5%
High voltage regulation	3.5 %
Color temperature	D65/D56/D93, selectable USER (3,200K-10,000K, factory setting is D65)

For PVM-20M2MDU/20M2MDE/20M2MDA

Normal scan	7 % over scan of CRT effective screen area
Under scan	5 % underscan of CRT effective screen area
Over scan	20 % over scan of CRT effective screen area
H. linearity	Less than 5.0 % (typical)
V. linearity	Less than 5.0 % (typical)
Convergence	
Central area:	Less than 0.6 mm (typical)
Peripheral area:	Less than 1.0 mm (typical)
Raster size stability	H: 1.0%, V: 1.5%
High voltage regulation	4.0 %
Color temperature	D65/D56/D93, selectable USER (3,200K-10,000K, factory setting is D65)

Inputs (common to all models)

LINE A	
VIDEO IN	BNC connector, 1Vp-p \pm 6 dB, sync negative
AUDIO IN	Phono jack (\times 1), -5 dBu ^a , more than 47 kilo-ohms
LINE B	
Y/C IN	4-pin mini-DIN (\times 1) <i>See the pin assignment on page 37.</i>
AUDIO IN	Phono jack (\times 1), -5 dBu ^a , more than 47 kilo-ohms
RGB/COMPONENT A/B	
R/R-Y,G/Y,B/B-Y IN:	BNC connector (\times 3) R, G, B channels: 0.7 Vp-p, \pm 6 dB Sync on green: 0.3 Vp-p, negative R-Y, B-Y channels: 0.7 Vp-p, \pm 6 dB Y channel: 0.7 Vp-p, \pm 6 dB (Standard color bar signal of 75% chrominance)
AUDIO IN	Phono jack (\times 1), -5 dBu ^a , more than 47 kilo-ohms
EXT SYNC IN	BNC connector (\times 1) 4 Vp-p, \pm 6 dB, sync negative
REMOTE	D SUB 9 PIN (\times 1), 8 PIN MIN DIN (\times 1) <i>See the pin assignment on page 37.</i>

a) 0 dBu = 0.775 Vr.m.s.

Outputs (common to all models)

LINE A	
VIDEO OUT	BNC connector (\times 1) loop-through, Automatic 75 ohms termination
AUDIO OUT	Phono jack loop-through
LINE B	
Y/C OUT	4-pin mini-DIN (\times 1) loop-through, Automatic 75 ohms termination
AUDIO OUT	Phono jack (\times 1) loop-through
RGB/COMPONENT A	
R/R-Y,G/Y,B/B-Y OUT:	BNC connector (\times 3) loop-through Automatic 75 ohms termination
AUDIO OUT	Phono jack (\times 1) loop-through
EXT SYNC OUT	BNC connector (\times 1) Automatic 75 ohms termination
DC OUT	8 V/0.8A
Speaker output	Output level: 0.8 W

General (common to all models)

Classification of equipment

- Evaluated to EN60601-1, EN60601-1-2, UL2601-1, CSA601.1
- Type of protection against electric shock
Class I equipment
- Degree of protection against harmful ingress of water
Ordinary equipment
- Degree of safety of application in the presence of a flammable anaesthetic mixture
Not protected equipment
- Mode of operation
Continuous operation
- Information concerning type and frequency of technical maintenance
Not need maintenance equipment
- Main power switch
Functional switch

CRT P-22 phosphor

Operating conditions

0 to +40°C (32 to 104°F) Temperature
700 to 1,060 hPa Pressure
30 to 85% (no condensation) Humidity

Transport and Storage conditions

-10 to +40°C (14 to 104°F) Temperature
700 to 1,060 hPa Pressure
0 to 90% Humidity

Accessories supplied

AC power cord (1)
AC plug holder (1)
Side Cover (2)
Control panel cover (1)
Panel hinge (2)
Remote control connector 8-pin mini
DIN (1)
Interface Manual for Programmers
(1)
Instructions for Use (1)

For PVM-14M2MDU:

Power requirements 1.2 ~ 0.5A
100 to 240 V AC, 50/60Hz¹⁾
Dimensions (w/h/d) Approx. 346 × 340 × 431 mm
(13⁵/₈ × 13¹/₂ × 17 inches)
not incl. projecting parts and controls
Mass Approx. 16.7kg (36 lb 13 oz)

For PVM-14M2MDE/14M2MDA:

Power requirements 1.2 ~ 0.5A
100 to 240 V AC, 50/60Hz¹⁾
Dimensions (w/h/d) Approx. 346 × 340 × 431 mm
(13⁵/₈ × 13¹/₂ × 17 inches)
not incl. projecting parts and controls
Mass Approx. 16.7kg (36 lb 13 oz)

For PVM-20M2MDU:

Power requirements 1.5 ~ 0.6A
100 to 240 V AC, 50/60Hz¹⁾
Dimensions (w/h/d) Approx. 450 × 458 × 503 mm
(17³/₄ × 18¹/₈ × 19⁷/₈ inches)
not incl. projecting parts and controls
Mass Approx. 30.0 kg (66 lb 2 oz)

For PVM-20M2MDE/20M2MDA:

Power requirements 1.5 ~ 0.6A
100 to 240 V AC, 50/60Hz¹⁾
Dimensions (w/h/d) Approx. 450 × 458 × 503 mm
(17³/₄ × 18¹/₈ × 19⁷/₈ inches)
not incl. projecting parts and controls
Mass Approx. 30.0 kg (66 lb 2 oz)

Design and specifications are subject to change without notice.

1) Use a proper power cord for your local power supply. (See page 22.)

Pin assignment

Y/C IN connector (4-pin mini-DIN)

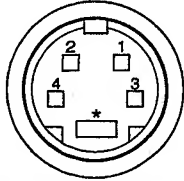

Pin No.	Signal	Description
1	Y-input	1 Vp-p, sync negative, 75 ohms
2	CHROMA subcarrier-input	300m Vp-p (PAL)/286m Vp-p (NTSC), burst Delay time between Y and C: within 0 ± 100 nsec., 75 ohms
3	GND for Y-input	GND
4	GND for CHROMA-input	GND

REMOTE 1 (8-pin mini DIN)

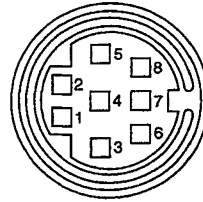

Pin No.	Signal
1	REMOTE ON/OFF
2	LINE A
3	GND
4	LINE B
5	TALLY
6	OVER SCAN
7	RGB A
8	RGB B

RS-232C (D-sub 9-pin)

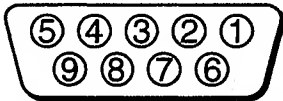

Pin No.	Signal
1	—
2	RX
3	TX
4	—
5	GND
6	—
7	RTS
8	CTS
9	—

**SAFETY CHECK-OUT
(US Model only)**

After correcting the original service problem, perform the following safety checks before releasing the set to the customer:

Check metal trim, "metallized" knobs, screws, and all other exposed metal parts for AC leakage. Check leakage as described below.

LEAKAGE

The AC leakage from any exposed metal part to earth ground and from all exposed metal parts to any exposed metal part having a return to chassis, must not exceed 0.5mA. Leakage current can be measured by any one of three methods.

1. A commercial leakage tester; such as the Simpson 229 or RCA WT-540A. Follow the manufacturers' instructions to use these instruments.
2. A battery-operated AC milliammeter. The Data Precision 245 digital multimeter is suitable for this job.
3. Measuring the voltage drop across a resistor by means of a VOM or battery-operated AC voltmeter. The "limit" indication is 0.75V, so analog meters must have an accurate low-voltage scale. The Simpson 250 and Sanwa SH-63Trd are examples of a passive VOM that is suitable. Nearly all battery operated digital multimeters that have a 2V AC range are suitable. (See Fig. A)

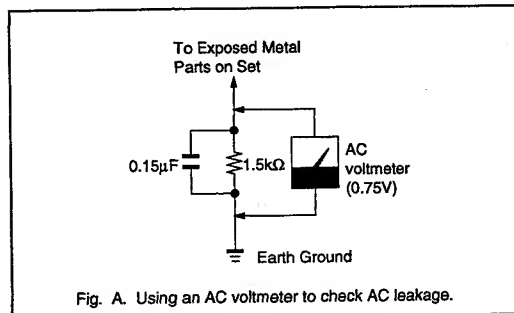

Fig. A. Using an AC voltmeter to check AC leakage.

(CAUTION)

SHORT CIRCUIT THE ANODE OF THE PICTURE TUBE AND THE ANODE CAP TO THE METAL CHASSIS, CRT SHIELD, OR CARBON PRINTED ON THE CRT, AFTER REMOVING THE ANODE.

WARNING!!

AN ISOLATION TRANSFORMER SHOULD BE USED DURING ANY SERVICE TO AVOID POSSIBLE SHOCK HAZARD, BECAUSE OF LIVE CHASSIS. THE CHASSIS OF THIS RECEIVER IS DIRECTLY CONNECTED TO THE AC POWER LINE.

SAFETY-RELATED COMPONENT WARNING!!

COMPONENTS IDENTIFIED BY SHADING AND MARK Δ ON THE SCHEMATIC DIAGRAMS, EXPLODED VIEWS AND IN THE PARTS LIST ARE CRITICAL TO SAFE OPERATION. REPLACE THESE COMPONENTS WITH SONY PARTS WHOSE PART NUMBERS APPEAR AS SHOWN IN THIS MANUAL OR IN SUPPLEMENTS PUBLISHED BY SONY. CIRCUIT ADJUSTMENTS THAT ARE CRITICAL TO SAFE OPERATION ARE IDENTIFIED IN THIS MANUAL. FOLLOW THESE PROCEDURES WHENEVER CRITICAL COMPONENTS ARE REPLACED OR IMPROPER OPERATION IS SUSPECTED.

(ATTENTION)

APRES AVOIR DECONNECTE LE CAP DE L'ANODE, COURT-CIRCUITER L'ANODE DE TUBE CATHODIQU ET CELUI DE L'ANODE DU CAP AU CHASSIS METALLIQUE DE L'APPAREIL OU AU COUCHE DE CARBONE PEINTE SUR LE TUBE CATHODIQUE OU AU BLINDAGE DU TUBE CATHODIQUE.

ATTENTION!!

AFIN D'EVITER TOUT RISQUE D'ELECTROCUTION PROVENANT D'UN CHASSIS SOUS TENSION, UN TRANSFORMATEUR D'ISOLEMENT DOIT ETRE UTILISE LORS DE TOUT DEPANNAGE. LE CHASSIS DE CE RECEPTEUR EST DIRECTEMENT RACCORDE A L'ALIMENTATION SECTEUR.

ATTENTION AUX COMPOSANTS RELATIFS A LA SECURITE!!

LES COMPOSANTS IDENTIFIES PAR UNE TRAME ET PAR UNE MAPQUE Δ SUR LES SCHEMAS DE PRINCIPE, LES VUES EXPLOSEES ET LES LISTES DE PIECES CONT D'UNE IMPORTANCE CRITIQUE POUR LA SECURITE DU FONCTIONNEMENT. NE LES REMPLACER QUE PAR DES COMPOSANTS SONY DONT LE NUMERO DE PIECE EST INDIQUE DANS LE PRESENT MANUEL OU DANS DES SUPPLEMENTS PUBLIES PAR SONY. LES REGLAGES DE CIRCUIT DONT L'IMPORTANCE EST CRITIQUE POUR LA SECURITE DU FONCTIONNEMENT SONT IDENTIFIES DANS LE PRESENT MANUEL. SUIVRE CES PROCEDURES LORS DE CHAQUE REMPLACEMENT DE COMPOSANTS CRITIQUES, OU LORSQU'UN MAUVAIS FONCTIONNEMENT EST SUSPECTE.

TABLE OF CONTENTS

1. GENERAL

Warning	1-1
Precautions	1-2
Features	1-2
Location and Function of Parts and Controls	1-3
Using On-Screen Menus	1-5
Power Sources	1-7
Attaching the Side Covers	1-7
Attaching the Control Panel Cover	1-7

2. DISASSEMBLY

2-1. Top and Rear Covers Removal	2-1
2-2. I/O Terminal Board Assy Removal	2-1
2-3. Service Position	2-1
2-4. H and J Boards Removal	2-2
2-5. Picture Tube and X Board Removal	2-3

3. SET-UP ADJUSTMENTS

3-1. Preparations (1)	3-1
3-2. Preparation (2). Initialization	3-5
3-3. Writing Model Data	3-5
3-4. Picture Output	3-6
3-5. Landing Adjustment	3-6
3-6. Convergence Adjustment (1)	3-7
3-7. Deflection Yoke Neck Rotation Adjustment	3-8
3-8. Convergence Adjustment (2)	3-9
3-9. G2 Adjustment	3-9
3-10. White Balance Adjustment	3-10
3-11. Sub Brt Adjustmet	3-10
3-12. Focus Adjustment	3-10

4. SAFETY RELATED ADJUSTMENT

4-1. Confirmation of +B Maximum	4-1
4-2. Confirmation of Hold-Down Circuit	4-1

5. CIRCUIT ADJUSTMENTS

5-1. A Board Adjustment	5-1
5-2. G and GA Boards Adjustment	5-9

6. DIAGRAMS

6-1. Block Diagrams	6-1
6-2. Frame Schematic Diagram	6-13
6-3. Circuit Boards Location	6-15
6-4. Schematic Diagrams and Printed Wiring Boards	6-16
Schematic Diagrams	
• H Board	6-18
• A (1/3) Board	6-25
• A (2/3) Board	6-30
• A (3/3) Board	6-35
• M Board	6-39
• G Board	6-39
• GA Board	6-39
• J Board	6-40
• X Board	6-40
• Q Board	6-41
• S Board (U/C model)	6-42
• C Board (14inch)	6-46
• C Board (20inch)	6-49
6-5. Semiconductors	6-52

7. EXPLODED VIEWS

7-1. Chassis [14M2MDU/E/A]	7-1
7-2. Picture Tube [14M2MDU/E/A]	7-2
7-3. Chassis [20M2MDU/E/A]	7-3
7-4. Picture tube [20M2MDU/E/A]	7-4

8. ELECTRICAL PARTS LIST

• A Board (14inch)	8-1
• A Board (20inch)	8-12
• M Board	8-24
• G Board	8-25
• GA Board	8-26
• C Board (20inch)	8-26
• C Board (14inch)	8-27
• H Board	8-28
• J Board	8-29
• X Board	8-29
• S Board	8-29
• Q board	8-29

SECTION 1 GENERAL

The operating instructions mentioned here are partial abstracts from the Operating Instruction Manual. The page numbers of the Operating Instruction Manual remain as in the manual.

English

WARNING

Owner's Record

The model and serial numbers are located at the rear. Record these numbers in the spaces provided below. Refer to these numbers whenever you call upon your Sony dealer regarding this product.

Model No. _____
Serial No. _____

To prevent fire or shock hazard, do not expose the unit to rain or moisture.

Dangerously high voltages are present inside the unit. Do not open the cabinet. Refer servicing to qualified personnel only.

In the event of a malfunction or when maintenance is necessary, consult an authorized Sony dealer.

This unit contains substances which can pollute the environment if disposed carelessly. Please contact our nearest representative office or your local environmental office in case of disposal of this unit.

Power Switch

The power switch is a functional switch only. To isolate the set from the mains supply remove the mains plug from the wall socket.

FOR CUSTOMERS IN THE UNITED KINGDOM

WARNING THIS APPARATUS MUST BE EARTHED

IMPORTANT
The wires in this mains lead are coloured in accordance with the following code:

GREEN-AND-YELLOW — EARTH
BLUE — LIVE
BROWN — NEUTRAL

As the colours of the wires in the mains lead of this apparatus may not correspond with the coloured markings identifying the terminals in your plug **PROCEED AS FOLLOWS:**

The wire coloured **GREEN AND YELLOW** must be connected to the terminal on the plug marked with the letter **E** or by the safety earth symbol \perp or coloured **GREEN** or **GREEN-AND-YELLOW**.

The wire coloured **BROWN** must be connected to the terminal marked with the letter **L** or coloured **RED**.
The wire coloured **BLUE** must be connected to the terminal marked with the letter **N** or coloured **BLACK**.

Ensure that your equipment is connected correctly — If you are in any doubt consult a qualified electrician.

FOR THE CUSTOMERS IN THE USA

This equipment has been tested and found to comply with the limits for a Class A digital device, pursuant to Part 15 of the FCC Rules. These limits are designed to provide reasonable protection against harmful interference when the equipment is operated in a commercial environment. This equipment generates, uses, and can radiate radio frequency energy and, if not installed and used in accordance with the instruction manual, may cause harmful interference to radio communications. Operation of this equipment in a residential area is likely to cause harmful interference in which case the user will be required to correct the interference at his own expense.

You are cautioned that any changes or modifications not expressly approved in this manual could void your authority to operate this equipment.

ATTENTION — When the product is installed in a rack:

a) **Elevated operating ambient temperature**
If installed in a closed or multi-unit rack assembly, the operating ambient temperature of the rack environment may be greater than room ambient. Therefore, consideration should be given to installing the equipment in an environment compatible with the manufacturer's maximum rated ambient temperature of 0 to +40° (Tmtr).

b) **Reduced air flow**
Installation of the equipment in a rack should be such that the amount of air flow required for safe operation of the equipment is not compromised.

c) **Mechanical loading**
Mounting of the equipment in the rack should be such that a hazardous condition is not achieved due to uneven mechanical loading.

d) **Circuit overloading**
Consideration should be given to the connection of the equipment to the supply circuit and the effect that overloading of circuits might have on overcurrent protection and supply wiring. Appropriate consideration of equipment nameplate ratings should be used when addressing this concern.

e) **Reliable earthing**
Reliable earthing of rack-mounted equipment should be maintained. Particular attention should be given to supply connections other than direct connections to the branch circuit (e.g., use of power strips).

Be sure to connect the AC power cord to a grounded outlet.

Warning

Important safeguards/notifications for use in the medical environments

1. All the equipments connected to this unit shall be certified according to Standard IEC601-1, IEC950, IEC65 or other IEC/ISO Standards applicable to the equipments.
2. When this unit is used together with other equipment in the patient area*, the equipment shall be either powered by an isolation transformer or connected via an additional protective earth terminal to system ground unless it is certified according to Standard IEC601-1 and IEC601-1-1.
* Patient Area

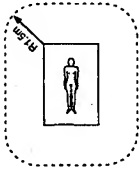

3. The leakage current could increase when connected to other equipment.

4. The operator should take precautions to avoid touching the rear panel input and output circuitry and the patient at the same time.

5. Model PYM-14M2MDU/14M2MDE/14M2MDA/20M2MDU/20M2MDE/20M2MDA is a video monitor intended for use in a medical environment to display video pictures from cameras or other video system.

Symbols on the unit

Symbol	Location	The symbol indicates
	Front panel	Main power switch. Press to turn the monitor on or off.
	Rear panel	The equipotential terminal which brings the various parts of a system to the same potential.
	Rear panel	Functional earth terminal
	Rear panel	Alternating current
	Rear panel	Attention, consult ACCOMPANYING DOCUMENTS

Warning on power connection

Use a proper power cord for your local power supply.

Plug type	United States	Canada	Continental Europe	Japan
Ferrule end	HOSPITAL GRADE E41395	HOSPITAL GRADE LL83182	LP-34A LS-60	VM1050 VM1010
Cord type	E41395-A	LL76662	H05VV-F 10A/250V	PVC/TF 12A/125V
Minimum cord set rating	10A/125V	10A/125V	10A/250V	12A/125V
Safety approval	UL	CSA	VDE	DENTOFI

English

Table of contents

Precautions	23
Features	24
Location and Function of Parts and Controls	25
Front Panel	25
Rear Panel	27
Using On-Screen Menus	29
Power Sources	33
Attaching the Side Covers	34
Attaching the Control Panel Cover	34
Specifications	35

Precautions

On safety

- Operate the unit on 100 - 240 V AC only.
- The nameplate indicating operating voltage, power consumption, etc. is located on the rear.
- Should any solid object or liquid fall into the cabinet, unplug the unit and have it checked by qualified personnel before operating it any further.
- Unplug the unit from the wall outlet if it is not to be used for several days or more.
- To disconnect the AC power cord, pull it out by grasping the plug. Never pull the cord itself.
- The socket-outlet shall be installed near the equipment and shall be easily accessible.

On installation

- Allow adequate air circulation to prevent internal heat build-up.
- Do not place the unit on surfaces (rugs, blankets, etc.) or near materials (curtains, draperies) that may block the ventilation holes.
- Do not install the unit in a location near heat sources such as radiators or air ducts, or in a place subject to direct sunlight, excessive dust, mechanical vibration or shock.

On cleaning

To keep the unit looking brand-new, periodically clean it with a mild detergent solution. Never use strong solvents such as thinner or benzene, or abrasive cleansers since they will damage the cabinet. As a safety precaution, unplug the unit before cleaning it.

On packing

Do not throw away the carton and packing materials. They make an ideal container which to transport the unit.

If you have any questions about this unit, contact your authorized Sony dealer.

Features

Picture

Trinitron® picture tube

Trinitron tube provides a high resolution picture. Horizontal resolution is more than 600 TV lines at the center of the picture.

Comb filter

When NTSC video signals are received, a comb filter activates to increase the resolution, resulting in fine picture detail without color spill or color noise.

Beam current feedback circuit

The built-in beam current feedback circuit assures stable white balance.

Inputs

Two color systems available

The monitor can display PAL, and NTSC signals. The appropriate color system is selected automatically.

Analog RGB/component input connectors

Analog RGB or component (Y, R-Y and B-Y) signals from video equipment can be input through these connectors. Press the RGB/COMPONENT A/B select button on the front panel and select RGB or component signals from the on-screen menu.

Y/C input connector (S input connector)

The video signal, split into the chrominance signal (C) and the luminance signal (Y), can be input through this connector, eliminating the interference between the two signals, which tends to occur in a composite video signal, assuring video quality.

External sync input connectors

When the external RGB or component signal is input and sync signal is set to external in the on-screen menu, the monitor can be operated on the sync signal supplied from an external sync generator.

Automatic termination

(only terminals with the ∇ mark)

The BNC input connectors on the rear panel are terminated at 75 ohms inside, when no cable is connected to the loop-through output connectors. When a cable is connected to an output connector, the 75-ohm termination is automatically released.

Functions

On-screen menus

You can set color temperature, CHROMA SET UP, and other settings by using the on-screen menus.

Overscan mode

The display size is enlarged by approximately 20% and the center part of the screen is easier to watch.

Underscan mode

The signal normally scanned outside of the screen can be monitored in the underscan mode.

Note

When the monitor is in the underscan mode, the dark RGB scanning lines may appear on the top edge of the screen. These are caused by an internal test signal, rather than the input signal.

Split function

The display splits into two parts (upper and lower). The upper part of the screen monitors the signal fed through the RGB/COMPONENT A input connectors and lower part of the screen monitors the signal fed through the RGB/COMPONENT B input connectors. You can compare the two screens.

Auto/manual degaussing

Degaussing of the screen can be performed automatically when the power is turned on, or manually by pressing the DEGAUSS button.

Five menu languages

You can select the language used for on-screen menus from the five languages.

Side cover(s) and control panel cover

The side covers that protect the ventilation holes from splashes (of medicines, etc.) as much as possible and a control panel cover that protects the control buttons on the front panel from undesired touching are supplied.

EIA standard 19-inch rack mounting

By using an MB-502B (for PVM-14M2MDU/14M2MDE/14M2MDA) or SLR-103A (for PVM-20M2MDU/20M2MDE/20M2MDA) Mounting Bracket (not supplied), the monitor can be mounted in an EIA standard 19-inch rack. For details on mounting, see the instruction manual of the mounting bracket kit.

1) Trinitron is a registered trademark of Sony Corporation.

Location and Function of Parts and Controls

Front Panel

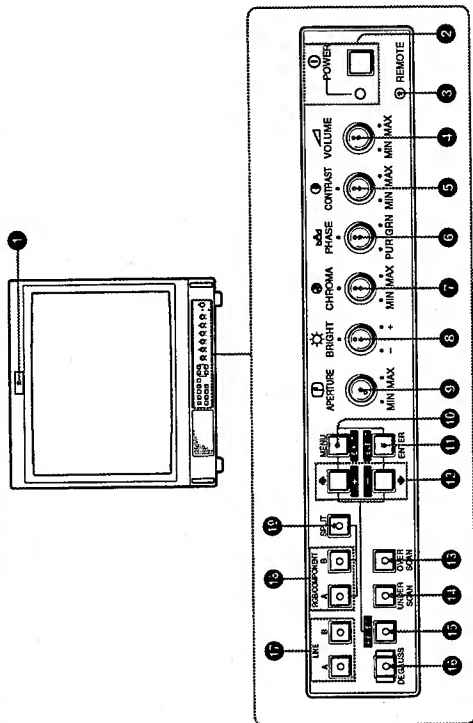

- 1 **Tally indicator**
This indicator lights up. The tally connection is needed.
For the pin assignment, see "Specifications" on page 37.
 - 2 **POWER switch and indicator**
Depress to turn the monitor on. The indicator will light up in green. To turn the power off, press this again.
 - 3 **REMOTE indicator**
This indicator lights up in the conditions below:
— When PRESET is set to ON in the menu.
— When REMOTE (RS-232C) is set to REMOTE ONLY or REMOTE & LOCAL in the menu, or
— When REMOTE ON is set via the REMOTE 1 terminal.
 - 4 **VOLUME control**
Turn this control clockwise or counterclockwise to obtain the desired volume.
 - 5 **CONTRAST control**
Turn clockwise to make the contrast stronger and counterclockwise to make it weaker.
 - 6 **PHASE control**
This control is effective only for the NTSC color system. Turn clockwise to make the skin tones greenish and counterclockwise to make them purplish.
 - 7 **CHROMA (chrominance) control**
Turn clockwise to make the color intensity stronger and counterclockwise to make it weaker.
 - 8 **BRIGHT (brightness) control**
Turn clockwise for more sharpness and counterclockwise for less.
When the control is set to MIN, the picture becomes flat without need for corrections.
 - 9 **APERTURE control**
Turn clockwise for more sharpness and counterclockwise for less.
When the control is set to MIN, the picture becomes flat without need for corrections.
- Note**
The APERTURE, CHROMA, PHASE control settings have no effect on the pictures of RGB signals. The PHASE control setting has no effect on the pictures of component signals.
- 10 **MENU (EXIT) button**
Press to make the menu appear.
Press to return to the previous screen in the menu.
 - 11 **ENTER (SELECT) button**
Press to decide a selected item in the menu.

Location and Function of Parts and Controls

- 12 **(+) / (-) buttons**
Press to move the cursor (▶) or adjust selected value in the menus.
 - 13 **OVERSCAN button**
Press (light on) for overscanning. The display size is extended by approximately 20% so that the center of screen is easier to watch. By pressing the button again, the display returns to the normal size (light off).
 - 14 **UNDERSCAN button**
Press (light on) for underscanning. The display size is reduced by approximately 5% so that four corners of the raster are visible. By pressing the button again, the display returns to the normal size (light off).
 - 15 **RESET button**
During menu adjustments, press to reset the setting in the menu.
 - 16 **DEGAUSS button**
Press this button momentarily. The screen will be demagnetized.
Wait for 10 minutes or more before activating this button again.
- Note**
The picture rolls vertically while the screen is being demagnetized.
- 17 **LINE A/B select buttons**
Press to select a signal (light on).
A: Press to monitor the signal fed through the LINE A input connectors.
B: Press to monitor the signal fed through the LINE B input connectors.
 - 18 **RGB/COMPONENT A/B select buttons**
Press to select a signal (light on).
A: Press to monitor the signal fed through the RGB/COMPONENT A input connectors.
B: Press to monitor the signal fed through the RGB/COMPONENT B input connectors.
 - 19 **SPLIT button**
When you select RGB signals fed through the RGB/COMPONENT A and RGB/COMPONENT B input connectors, press this button (light on) to split the display into two parts (upper and lower), and monitor the both RGB signals simultaneously.
- Note**
Make sure the signals fed through the RGB/COMPONENT A and RGB/COMPONENT B input connectors are synchronized.

Location and Function of Parts and Controls

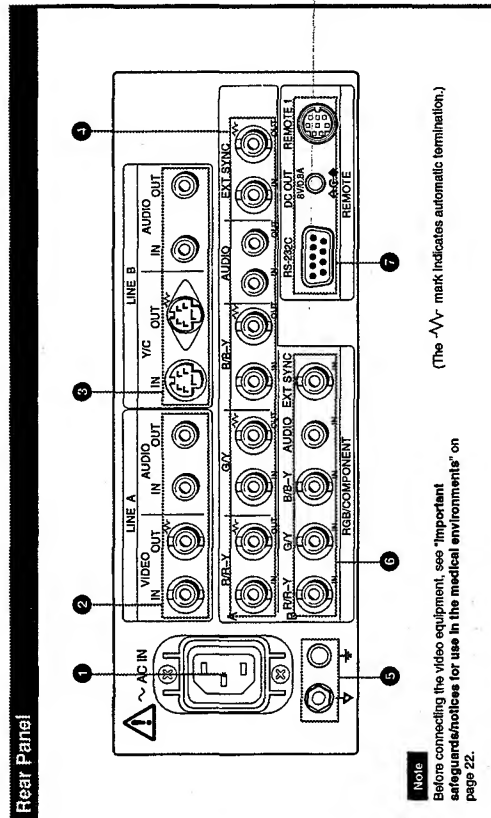

- 4 RGB/COMPONENT A connectors**
RGB signal or component signal input connectors and their loop-through output connectors.
To monitor the input signal fed through these connectors, press the RGB/COMPONENT A select button (light on) on the front panel.
Then select one out of four items in the RGB A SYSTEM menu to set the RGB or COMP (component) signal and the INT SYNC (internal sync) or EXT SYNC (external sync) signal.
For the operation through the menus, see pages 29 to 32.
- 5 Ground (∇/\pm) terminal**
Connect a GND cable.
- 6 RGB/COMPONENT B connectors**
RGB signal or component signal input connectors. To monitor the input signal fed through these connectors, press the RGB/COMPONENT B select button (light on) on the front panel.
Then select one out of four items in the RGB B SYSTEM menu to set the RGB or COMP (component) signal and the INT SYNC (internal sync) or EXT SYNC (external sync) signal.
For the operation through the menus, see pages 29 to 32.
- R/R-Y IN, G/Y IN, B/B-Y IN (BNC)**
When "RGB-INT SYNC" or "COMP-INT SYNC" is selected in the RGB A SYSTEM menu, the monitor operates on the sync signal from the G/Y channel.
To monitor the RGB signal
Connect to the analog RGB signal output connectors of a video camera.
To monitor the component signal
Connect to the R-Y/Y/B-Y component signal output connectors of a Sony Betacam equipment.
- R/R-Y IN, G/Y IN, B/B-Y IN (BNC)**
When "RGB-INT SYNC" or "COMP-INT SYNC" is selected in the RGB B SYSTEM menu, the monitor operates on the sync signal from the G/Y channel.
To monitor the RGB signal
Connect to the analog RGB signal output connectors of a video camera.
To monitor the component signal
Connect to the R-Y/Y/B-Y component signal output connectors of a Sony Betacam equipment.
- R/R-Y OUT, G/Y OUT, B/B-Y OUT (BNC)**
Loop-through outputs of the R/R-Y IN, G/Y IN, B/B-Y IN connectors.
When the cables are connected to these connectors, the 75-ohms termination of the inputs is automatically released, and the signal inputs to the R/R-Y IN, G/Y IN, B/B-Y IN connectors are output from these connectors.
To output the analog RGB signal
Connect to the analog RGB signal input connectors of a video printer or another monitor.
To output the component signal
Connect to the R-Y/Y/B-Y component signal input connectors of a Sony Betacam equipment.
- AUDIO IN (phono jack)**
Connect to the audio output connector of video equipment when the analog RGB or component signal is input.
- EXT SYNC (external sync) IN (BNC)**
When this monitor operates on an external sync signal, connect the signal from a sync generator to this connector.
To use the sync signal fed through this connector, select "RGB-EXT SYNC" or "COMP-EXT SYNC" in the RGB B SYSTEM menu.
- REMOTE connectors**
RS-232C (D-sub 9-pin)
Connect to the RS-232C control connector of other equipment. You can operate the monitor with the control command from the equipment.
For the details, see the supplied Interface Manual for Programmers.
- REMOTE 1 (8-pin mini DIN)**
Connect to the tally output connector of a control console, effects, etc. The tally indicator on the front panel will be turned on and off by the connected equipment.
You can also connect a remote controller using this connector.
For the pin assignments of these connectors, see "Specifications" on page 37.
- DC OUT 8V/0.8A connector**
You can use this connector as a power source for the other equipment.
DC 8V/0.8A is output.

- 1 AC IN socket**
Connect the supplied AC power cord to this socket. ~V- means Alternating Current.
- 2 LINE A connectors**
Line input connectors for the composite video and audio signals and their loop-through output connectors.
To monitor the input signal fed through these connectors, press LINE A select button (light on) on the front panel.
- VIDEO IN (BNC)**
Connect to the video output connector of a video equipment, such as a VTR or a color video camera. For a loop-through connection, connect to the video output connector of another monitor.
- VIDEO OUT (BNC)**
Loop-through output of the VIDEO IN connector. Connect to the video input connector for a VTR or another monitor.
When the cable is connected to this connector, the 75-ohms termination of the input is automatically released, and the signal input to the VIDEO IN connector is output from this connector.
- AUDIO IN (phono jack)**
Connect to the audio output connector of a VTR or to a microphone through a suitable microphone amplifier. For a loop-through connection, connect to the audio output connector of another monitor.
- AUDIO OUT (phono jack)**
Loop-through output of the AUDIO IN connector. Connect to the audio input connector of a VTR or another monitor.
- LINE B connectors**
Separated Y/C input connectors, audio input connectors, and corresponding loop-through output connectors.
To monitor the input signal fed through these connectors, press LINE B select button (light on) on the front panel.
- Y/C IN (4-pin mini DIN)**
Connect to the Y/C separate output connector of a VTR, video camera or other video equipment.
- Y/C OUT (4-pin mini DIN)**
Loop-through output of the Y/C IN connector. Connect to the Y/C separate input connector of a VTR or another monitor.
When the cable is connected to this connector, the 75-ohms termination of the input is automatically released, and the signal input to the Y/C IN connector is output from this connector.
- AUDIO IN (phono jack)**
Connect to the audio output connector of a VTR or to a microphone through a suitable microphone amplifier. For a loop-through connection, connect to the audio output connector of another monitor.
- AUDIO OUT (phono jack)**
Loop-through output of the AUDIO IN connector. Connect to the audio input connector of a VTR or another monitor.

Using On-Screen Menus

Menu Configuration

The flow chart shows the different levels of on-screen menus that you can use to make various adjustments and settings.

For details of each menu, see pages 30 to 32.

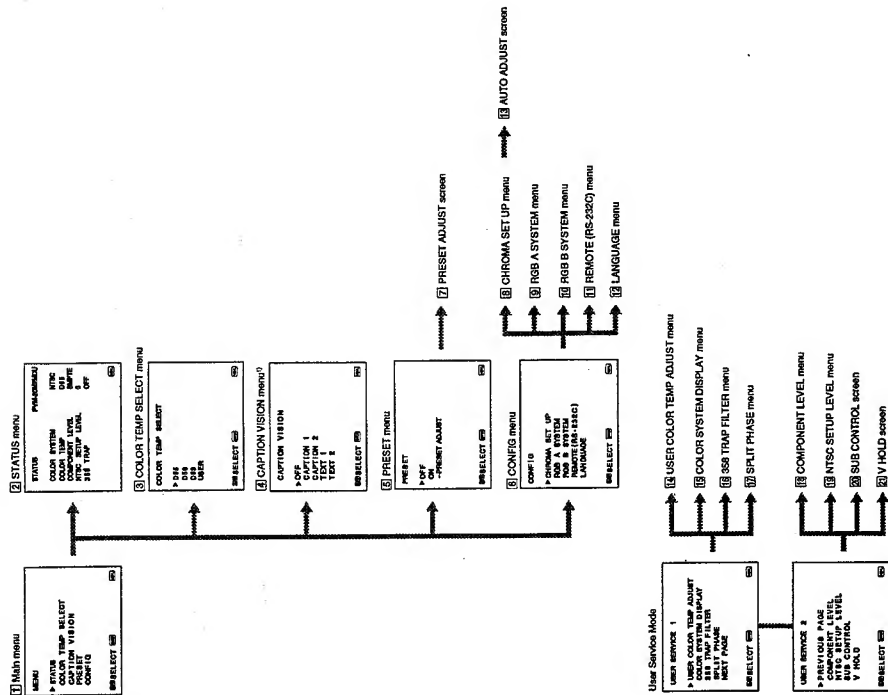

1) CAPTION VISION in the Main menu is designed for an exclusive use with the PVM-20M2MDU and 14M2MDU models.

Using On-Screen Menus

Operating through Menus

There are five buttons for menu operations on the front panel of the monitor. To display the main menu, first press MENU (EXIT). The buttons you can use appear at the bottom of the menu screen.

Functions of the buttons

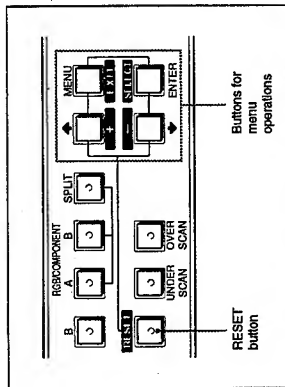

Button	To select menu item	To adjust selected menu item
MENU	return to the previous menu.	return to the previous menu.
ENTER	select an item.	select an item.
↑	move the cursor upwards.	increase selected value.
↓	move the cursor downwards.	decrease selected value.
RESET		reset current adjustment value to the factory setting.

(The above items in white type correspond to the marks in the menu.)

For PVM-14M2MDE/14M2MDA/20M2MDE/20M2MDA:

For the first time when the monitor is turned on, the LANGUAGE menu (14) will appear on the screen. So, select the language you want to use.



- 1 Move the cursor (▶) to the desired language by pressing the ←/→ or ↑/↓ button.
- 2 Press the MENU (EXIT) button.

Note

Unless you press the MENU (EXIT) button in the procedure above, the LANGUAGE menu will always appear whenever you turn on the monitor.

The Contents of Menu Items

The following sentences show the details of each menu items.

[] indicates the factory setting position.

- 1 **Main menu**
Select an item and press the ENTER (SELECT) button to go to the following menu.
- 2 **STATUS menu**
Shows the current settings.
- 3 **COLOR TEMP SELECT menu**
Select the color temperature from among D65, D56, D93 and USER. USER is set to D65 in the factory setting. You can adjust or change the color temperature in USER mode (a measuring instrument is needed). [D65]

Note

The color temperature of the USER mode can be adjusted in the range from 3200K to 10000K. You can adjust the color temperature of the USER mode in the USER COLOR TEMP ADJUST menu (14) of the user service mode. For the details, see USER COLOR TEMP ADJUST menu (14) on page 31.

- 4 **CAPTION VISION menu**
This menu is provided only for PVM-20M2MDU/14M2MDU.
The monitor can display the signal with Caption Vision. To display it, select the caption type in this menu. [OFF]

Using On-Screen Menus

- [17] SPLIT PHASE menu**
When the SPLIT function is activated, if the lower side picture (the signal fed through the RGB/COMPONENT B input connectors) has some discrepancy of location with the upper side picture, adjust the SPLIT PHASE menu.
Each time you press the \blacktriangle (+) button, the lower side picture moves left. [MIN]

Note
When the adjustment is made in the menu, the skew error will occur on the top of the lower side picture.

- [18] COMPONENT LEVEL menu**
Select the component level from among three modes.
NTSC SMPTE: for 1000/1000/0 signal
BETA 7.5: for 1000/7.5/7.5 signal
BETA 0: for 1000/7.5/0 signal
For PVM-20M2MDE/20M2MDA/14M2MDE/14M2MDA [N10/SMPTE]
For PVM-20M2MDU/14M2MDU [BETA 0]
- [19] NTSC SETUP LEVEL menu**
Select the NTSC setup level from two modes. The 7.5 setup level is mainly used in north America. The 0 setup level is mainly used in Japan.
For PVM-20M2MDE/20M2MDA/14M2MDE/14M2MDA [0]
For PVM-20M2MDU/14M2MDU [7.5]

- [20] SUB CONTROL screen**
You can finely adjust the controls on the front panel. CONTRAST, PHASE, CHROMA and BRIGHT controls have clicks at the center of their adjustment range. You can adjust the setting of the click position with this feature.

- [21] V HOLD screen**
Adjust the vertical hold if the picture rolls vertically.
- Note**
If the rolling of the picture prevents you from watching the screen, select an input that has nothing connected.

- [13] AUTO ADJUST screen**
Select the color bar signal (full, SMPTE, EIA) and press the ENTER (SELECT) button to start automatic adjustment for CHROMA and PHASE. For these adjustments to be valid, you must select ON in CHROMA SET UP menu ([8]).

User Service Mode

The user service mode is useful when adjusting the settings and controls except for the above.
To enter the user service mode, press and hold the MENU (EXIT) button until the following USER SERVICE 1 appears.

To move to the second page of the mode, select "NEXT PAGE", and to return to the first page, select "PREVIOUS PAGE".

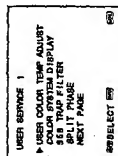
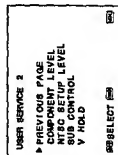

- [14] USER COLOR TEMP ADJUST menu**
The value of adjustment in this menu works only when "USER" is selected in the COLOR TEMP SELECT menu ([3]).

- ADJUST GAIN:**
Adjusts the color balance (gain) of the USER mode.
ADJUST BIAS:
Adjusts the color balance (bias) of the USER mode.
COLOR TEMP RANGE:
When you adjust the color temperature in the USER mode, select a color temperature range before adjusting ADJUST GAIN and ADJUST BIAS. If the adjusted color temperature is between 3200K and 5000K, select "3200K-5000K". If the adjusted color temperature is between 5000K and 10000K, select "5000K-10000K".

- USER COPY:**
Selects the color temperature of the USER mode from among D65, D56 and D93.

- [15] COLOR SYSTEM DISPLAY menu**
Select the color system display mode. In AUTO, the kind of color system being used appears on the screen each time you change the signal input. [AUTO]

- [16] TRAP FILTER menu**
Color spill or color noise may be eliminated if you select ON (NTSC signal only). Normally set it to OFF. [OFF]

- [5] PRESET menu**
You can preset each control to a desired level and set it. If you set PRESET to ON, the REMOTE indicator lights up and the controls on the front panel do not work. The monitor operates with the internal memory settings. For adjustment, select the PRESET ADJUST screen. [OFF]

- [6] CONFIG menu**
Select an item for adjustment of the monitor. [OFF]

- [7] PRESET ADJUST screen**
Adjust CONTRAST, BRIGHT, CHROMA, PHASE, VOLUME, APERTURE in the PRESET menu.

- [8] CHROMA SET UP menu**
Set to ON to adjust the internal decoder for CHROMA and PHASE (NTSC signal only) after AUTO ADJUST screen ([3]). [OFF]

- [9] RGB A SYSTEM menu**
To monitor the signal fed through the RGB/COMPONENT A connectors, set the RGB or COMP (component) signal and the INT SYNC (internal sync) or EXT SYNC (external sync) signal in this menu. [RGB-EXT SYNC]

- [10] RGB B SYSTEM menu**
To monitor the signal fed through the RGB/COMPONENT B connectors, set the RGB or COMP (component) signal and the INT SYNC (internal sync) or EXT SYNC (external sync) signal in this menu. [RGB-EXT SYNC]

- [11] REMOTE (RS-232C) menu**
Select one out of following three modes.
REMOTE OFF:
You can adjust settings and controls by the buttons and controls on the front panel.
The RS-232C connector does not function.
REMOTE ONLY:
You can adjust settings and controls through the RS-232C connector.
Buttons and controls on the front panel, except the menu operation ones, do not function.

- REMOTE & LOCAL:**
You can adjust settings and controls both through the RS-232C connector and the front panel buttons.
Controls on the front panel do not function. [REMOTE OFF]

- [12] LANGUAGE menu**
You can select the language used for on-screen menus from the following five languages (English, German, French, Italian, Spanish). [ENGLISH]

Power Sources

House Current

Connect the supplied AC power cord to the AC IN socket on the rear panel and to a wall outlet.

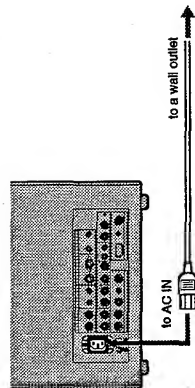

To connect an AC power cord securely with the AC plug holder

1

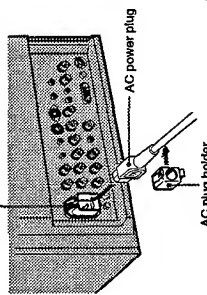

Plug the power cord into the AC IN socket. Then, attach the AC plug holder (supplied) on top of the AC power cord.

2

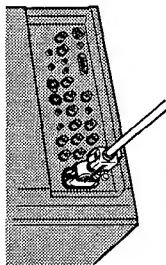

Slide the AC plug holder over the cord until it connects with the attached holder.

To remove the AC power cord

Pull out AC plug holder by squeezing the up and down sides.

Attaching the Side Covers

In order to protect the ventilation holes from medicines, etc., attach the side covers (supplied) as shown below.

1

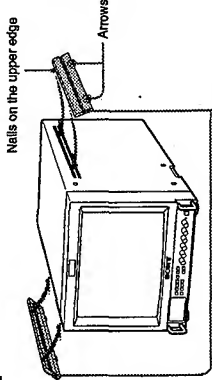

Making sure the arrows on the side cover are facing down, hook the nails on the upper edge into the ventilation holes.

NOTE

Attach the side covers to all their ventilation holes.

2

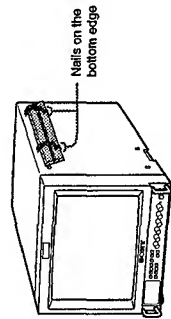

Push up the nails on the bottom edge and fit the cover into the lowest ventilation holes. Attach the both covers to the left and right sides.

Attaching the Control Panel Cover

In order to protect the control buttons on the front panel from undesired touching, attach the supplied control panel cover.

1

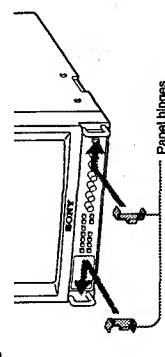

Attach the panel hinges to the left and right grips from the inner side.

2

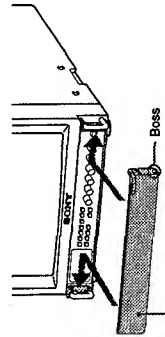

Fit the bosses on the both sides of the control panel cover into the lower holes of the panel hinges with bending the control panel cover a little.

SECTION 2 DISASSEMBLY

2-1. TOP AND REAR COVERS REMOVAL

(1) 14M2MDU/E/A

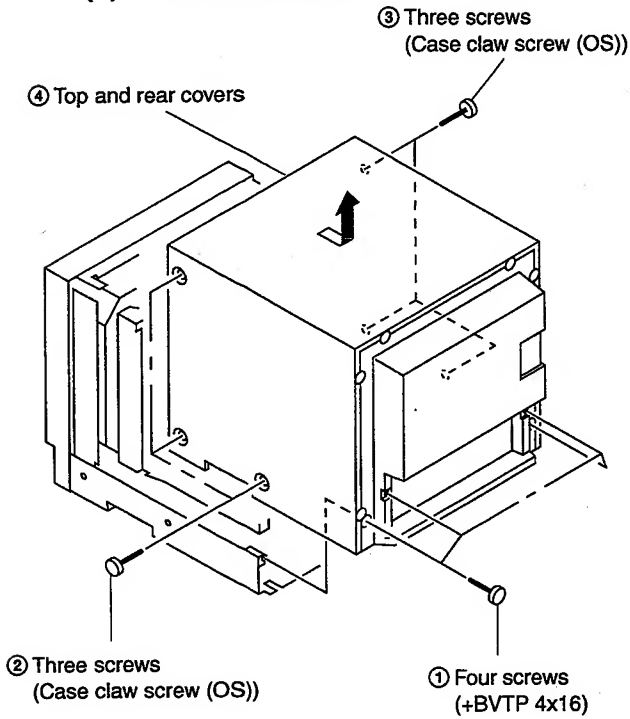

(2) 20M2MDU/E/A

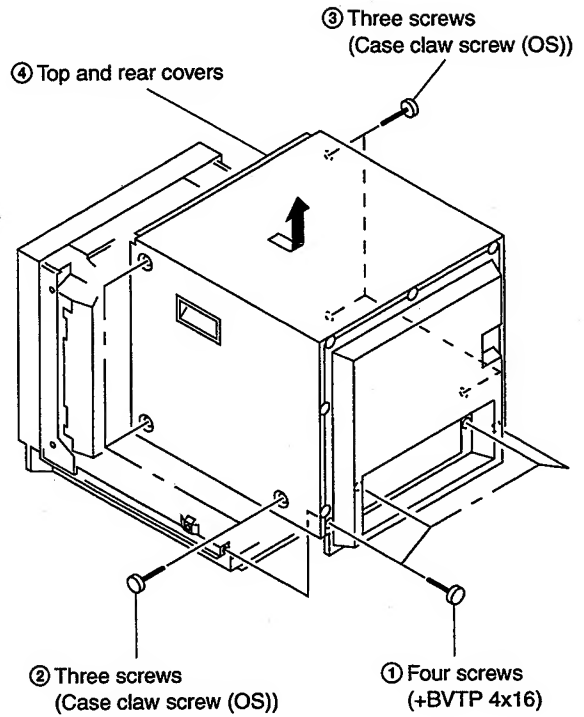

2-2. I/O TERMINAL BOARD ASSY REMOVAL

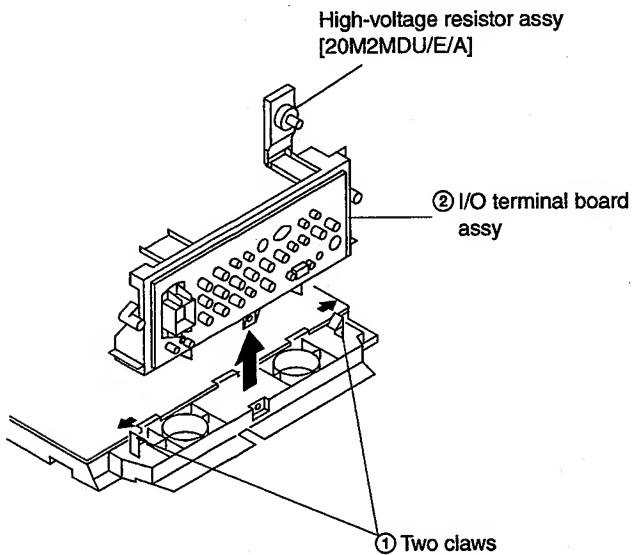

2-3. SERVICE POSITION

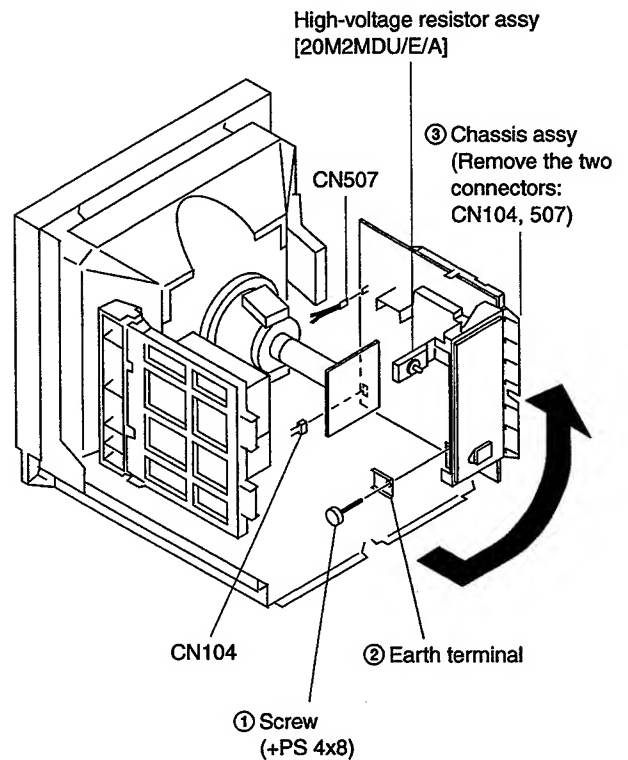

2-4. H AND J BOARDS REMOVAL

(1) 14M2MDU/E/A

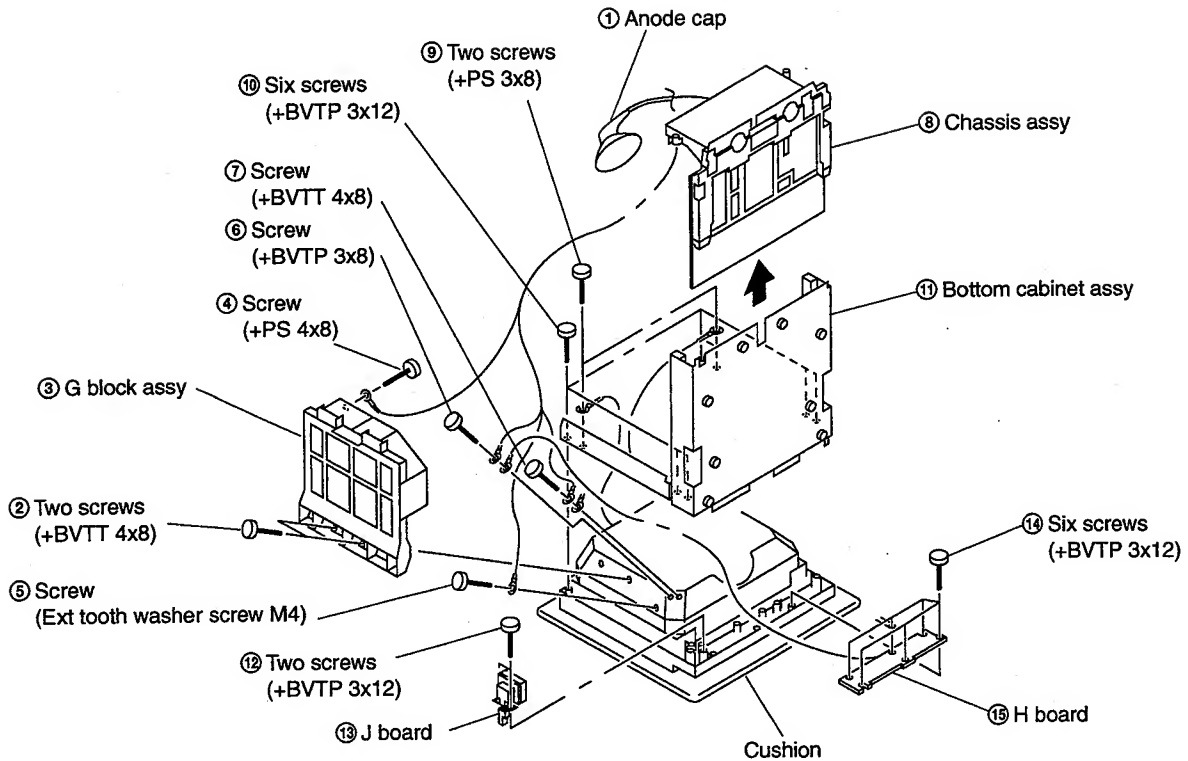

(2) 20M2MDU/E/A

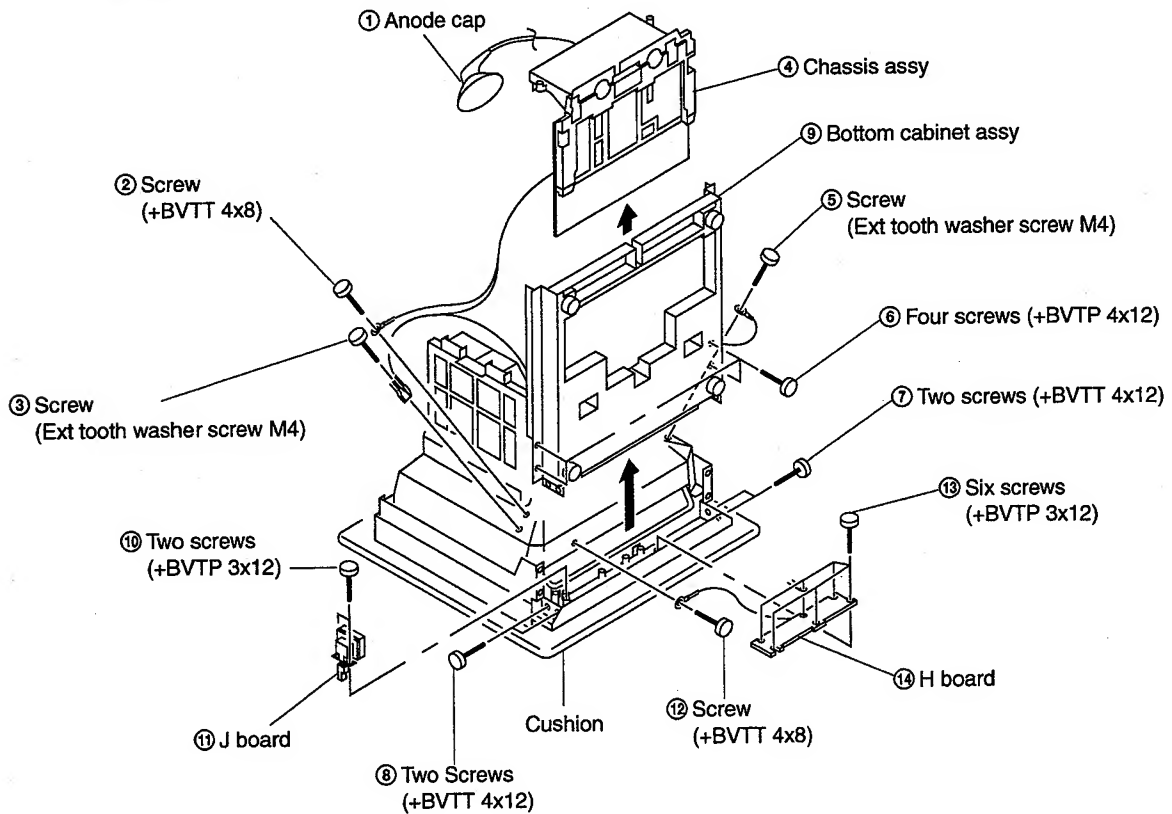

2-5. PICTURE TUBE AND X BOARD REMOVAL

(1) 14M2MDU/E/A

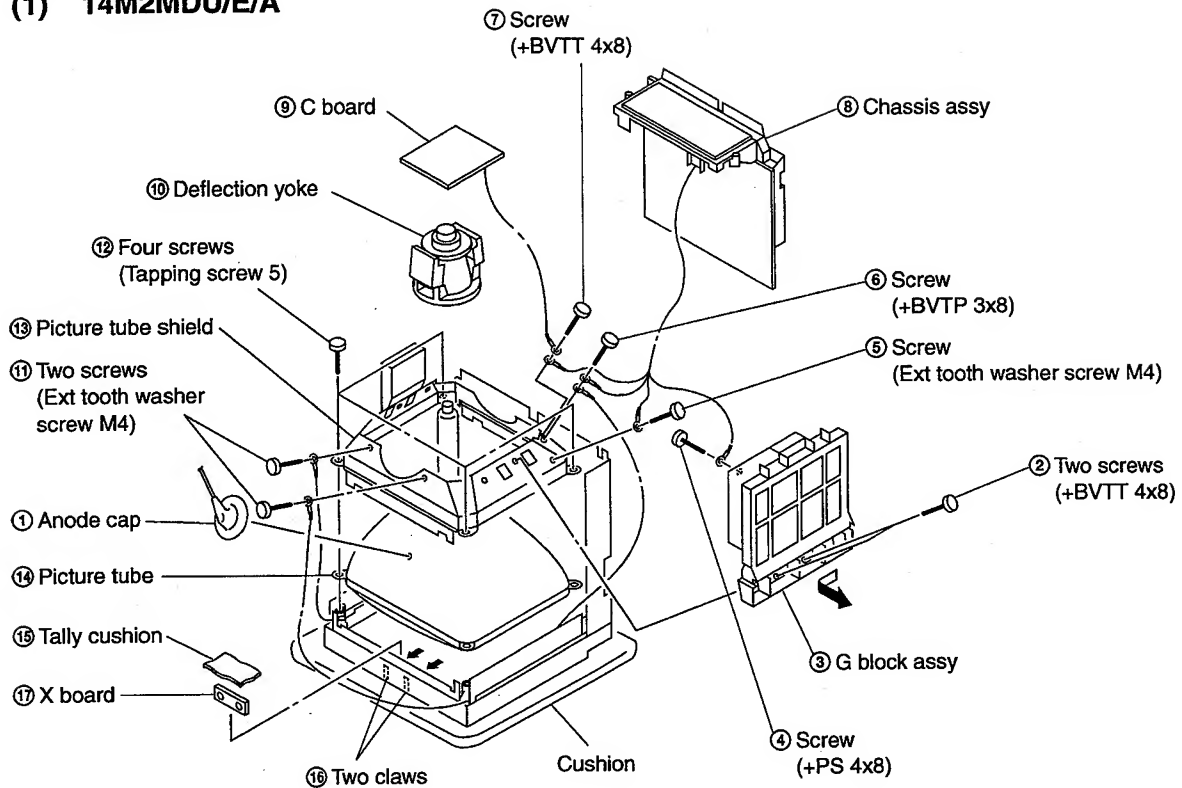

(2) 20M2MDU/E/A

•Remove the chassis assy and bottom cabinet assy. (Refer to 2-4. (2))

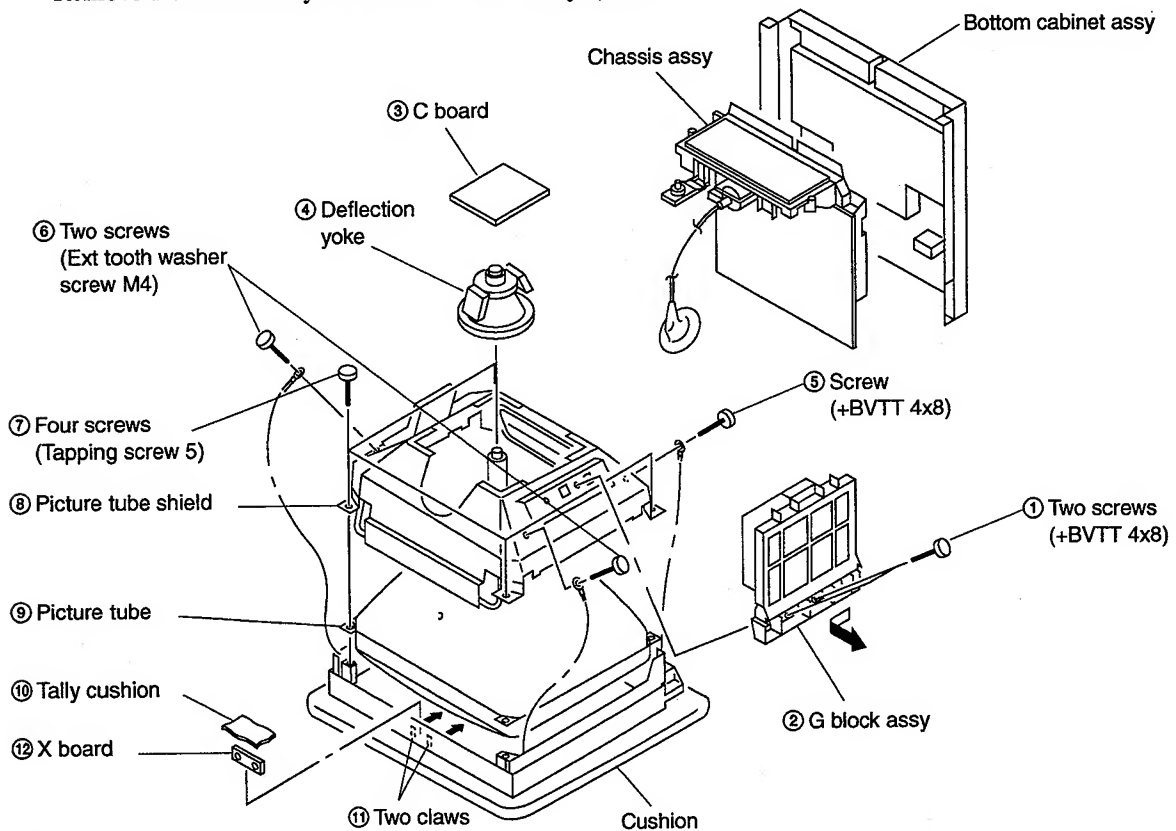

• **REMOVAL OF ANODE-CAP**

NOTE : Short circuit the anode of the picture tube and the anode cap to the metal chassis, CRT shield or carbon paint on the CRT, after removing the anode.

• **REMOVING PROCEDURES**

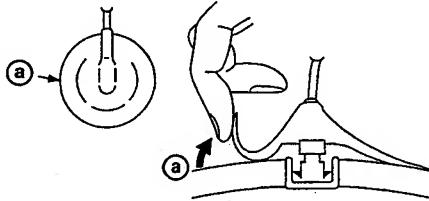

① Turn up one side of the rubber cap in the direction indicated by the arrow (a).

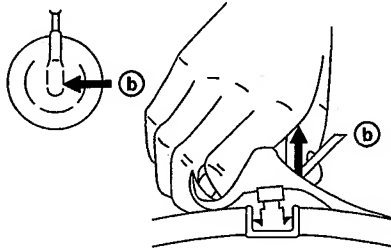

② Using a thumb pull up the rubber cap firmly in the direction indicated by the arrow (b).

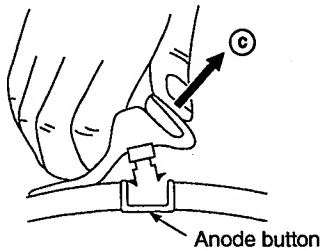

③ When one side of the rubber cap is separated from the anode button, the anode-cap can be removed by turning up the rubber cap and pulling up it in the direction of the arrow (c).

• **HOW TO HANDLE AN ANODE-CAP**

- ① Don't hurt the surface of anode-caps with shaped material!
- ② Don't press the rubber hardly not to hurt inside of anode-caps!
A material fitting called as shatter-hook terminal is built in the rubber.
- ③ Don't turn the foot of rubber over hardly!
The shatter-hook terminal will stick out or hurt the rubber.

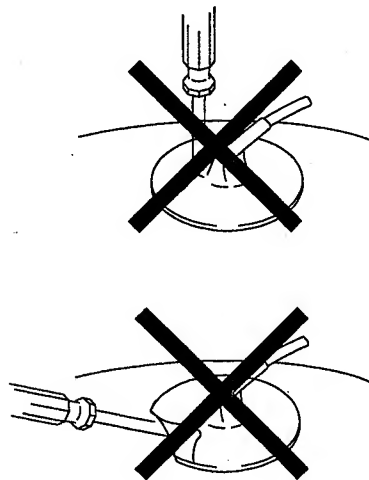

SECTION 3

SET-UP ADJUSTMENTS

3-1. PREPARATIONS (1)

SERVICE MODE

This set is provided with a switch for service on the front panel that can be used to make various adjustments. The operation method of this switch is explained in detail below.

1. Entering the service mode I

① Service mode I

While the menu is displayed, press the [ENTER] and [DEGAUSS] keys simultaneously.

② Service mode II

While the service mode I is displayed, press the [U/S] and [ENTER] keys simultaneously.

2. Service mode display

Range of Service Mode Display

(1)	(5)	(4)	(3)	(6)
(2)				

- (1) The service items are largely classified into 16 types displayed by titles.
- (2) The names of the service items or READ/WRITE guidance, etc., are displayed. The names are displayed to the left and the guidance to the right.
- (3) This is the serial number for each of the service items. 1-107.
- (4) This is the adjustment data for the service items that are now stored in the RAM. Adjustments can be made by changing these values, but as long as nothing is written to the ROM the adjustment values will be erased by turning off the power or by reading, so please be careful.
- (5) When the adjustment data that is now displayed is identical with the data in the ROM, the cursor (▶) is displayed.
- (6) The present status is displayed.
 [*]: Writing to the ROM. Make sure not to turn off the power while this display is on.
 [?]: ROM reading error. In this case, an image is output with the standard adjustment data that the microcomputer itself possesses.
 [⌂]: Problem in the I²C bus.

3. Ending the service mode

In the case of the service mode I, press the [ENTER] and [DEGAUSS] keys simultaneously while the service mode is displayed.

In the case of the service mode II, press the [U/S] and [ENTER] keys simultaneously.

4. Easy ON/OFF of the service mode

If once entering the service mode after having turned on the power, easy ON/OFF is possible by once more pressing the A, B or C switch on the front panel (the LED lights) as long as the power is not turned off or as long as the service mode is not finished.

(No function in service mode II)

5. Change of position of the service mode display

If the switch is continuously pressed when turning on in the above easy mode, the display position moves in the V direction. This method is used when the display is outside of the effective screen area.

6. Change of service items

The items are returned with the [MENU] key and forwarded with the [ENTER] key. When a key is continuously pressed, the operation will be repeated.

7. Change of service data

The service data is made larger with the [↑] key and smaller with the [↓] key. When continuously pressing the keys, the operation will be repeated.

8. Reading of service data

When reading data from the ROM to the RAM, press the [RESET] key once and check that the READ display is shown in the guidance, and then press the [RESET] key once again. The adjustment data that is written will return to its previous state, so please be careful.

9. Writing of service data

When writing data from the RAM to the ROM, press the [DEGAUSS] key once and check that the WRITE display shown in the guidance, and then press the [DEGAUSS] key once again. Not only the displayed data will be written, but all data, so please be careful.

10. Carrying out FACTORY RESETTING

In case the adjustment data has been destroyed for some reason, and you keep pressing the [B/O] key at the beginning of the above reading, the READ guidance will change to FACTORY RESET guidance in approximately 3 seconds so that the factory resetting can be carried out. By once again pressing the [RESET] key after this, resetting will be carried out ([*] will be displayed as status) and factory resetting will be executed. However, in case the data available at the time of shipment from the factory has been destroyed, or if the ROM has been replaced, etc., or if factory setting mentioned later on has been carried out, factory resetting is executed.

11. Carrying out FACTORY SETTING

Make sure to make possible the above factory resetting by making a copy of the adjustment data when replacing the ROM. If you keep pressing the [DEGAUSS] key at the beginning of the above writing, the WRITE guidance will change into FACTORY RESET guidance after approximately 3 seconds. By once again pressing the [DEGAUSS] key after this, setting will be carried out ([*] will be displayed as status) and the data will be copied. By carrying out this operation, the selection items of the menu and the adjustment values will be reset to the standard conditions, so please be careful. If this operation is carried out once, it cannot be carried out again, but the FACTORY SET FLAG (No. 107) in the service mode can be set to 1.

1. SERVICE MAP I

※ Signify (The setting is vary with the destination.)
Refer to the "Table 3-1-2 SERVICE MAP I (2)."

Table 3-1-1 SERVICE MAP I (1)

No.	SERVICE ITEM		MAX	STD	No.	SERVICE ITEM		MAX	STD
1	NOR 50 DEF	H FREQUENCY	255	85	55	C/T2 D??	GAIN <GREEN>	1023	700
2		VIDEO PHASE	255	140	56		GAIN <BLUE>	1023	500
3		V SIZE	255	170	57	C/T3 D??	3200K SW	1	0
4	NOR 60 DEF	H FREQUENCY	255	96	58		BIAS <RED>	1023	500
5		VIDEO PHASE	255	128	59		BIAS <GREEN>	1023	300
6		V SIZE	255	170	60		BIAS <BLUE>	1023	400
7	NOR DEF	V CENTER	255	128	61		GAIN <RED>	1023	700
8		H SIZE	255	100	62		GAIN <GREEN>	1023	700
9		PIN PHASE	255	128	63		GAIN <BLUE>	1023	700
10		PIN AMP	255	128	64	USER C/T ORG	3200K SW	1	0
11		LOWER PIN AMP	255	128	65		BIAS <RED>	1023	600
12		UPPER PIN AMP	255	128	66		BIAS <GREEN>	1023	300
13		SEXY	255	128	67		BIAS <BLUE>	1023	300
14		V LINEARITY	255	128	68		GAIN <RED>	1023	800
15		V BOW	63	35	69		GAIN <GREEN>	1023	700
16		LOWER V BOW	63	20	70		GAIN <BLUE>	1023	500
17		V ANGLE	63	20	71	W/B	SUB CON <NORMAL>	255	178
18	U/S DEF	V SIZE <50>	255	140	72		SUB CON <O/S>	255	178
19		V SIZE <60>	255	140	73		SUB BRIGHT	255	69
20		H SIZE	255	128	74	OTHER	LANDING	255	64
21		PIN PHASE	255	128	75		SPLIT PHASE	255	0
22		PIN AMP	255	100	76		DEGAUSS DELAY	127	0
23	O/S DEF	V SIZE <50>	255	190	77		V HOLD	255	128
24		V SIZE <60>	255	190	78		H BLANKING	255	73
25		H SIZE	255	128	79		O/S H BLANKING START	255	73
26		PIN PHASE	255	128	80		O/S H BLANKING END	255	76
27		PIN AMP	255	150	81		V BLANKING <50>	255	82
28	COMPONENT	SUB PHASE	255	130	82		O/S UPPER V BLK <50>	255	14
29		SUB CHROMA <NORMAL>	255	182	83		O/S LOWER V BLK <50>	255	177
30		SUB CHROMA <SMPTE>	255	170	84		V BLANKING <60>	255	161
31		R-Y LEVEL	255	163	85		O/S UPPER V BLK <60>	255	19
32	NTSC	BURST GATE PULSE WIDTH	255	52	86		O/S LOWER V BLK <60>	255	230
33		CRYSTAL	255	59	87		HP POSITION	255	145
34		PHASE	255	80	88		HP WIDTH	255	148
35		B-Y PHASE	255	162	89	SYSTEM	358 TRAP FILTER	1	0
36		CHROMA	255	98	90		CAPTION VISION	7	0
37		R-Y LEVEL	255	98	91		COMPONENT LEVEL	3	※
38	PAL	CRYSTAL	255	82	92		NTSC SETUP LEVEL	1	※
39		PHASE	255	110	93		CHROMA SET UP	1	0
40		B-Y PHASE	255	122	94		COLOR SYSTEM DISPLAY	3	0
41		CHROMA	255	109	95		COLOR TEMPERATURE	3	0
42		R-Y LEVEL	255	121	96		USER PRESET	1	0
43	C/T1 D??	3200K SW	1	0	97		LANGUAGE	7	0
44		BIAS <RED>	1023	600	98		RGB MODE A	3	1
45		BIAS <GREEN>	1023	300	99		RGB MODE B	3	1
46		BIAS <BLUE>	1023	300	100		AGING MODE	1	0
47		GAIN <RED>	1023	800	101		REMOTE MODE KEY	1	0
48		GAIN <GREEN>	1023	700	102		MODEL	31	※
49		GAIN <BLUE>	1023	500	103		COLOR TEMP DISP 1	127	65
50	C/T2 D??	3200K SW	1	0	104		COLOR TEMP DISP 2	127	56
51		BIAS <RED>	1023	700	105		COLOR TEMP DISP 3	127	93
52		BIAS <GREEN>	1023	300	106		REMOTE ADDRESS	63	1
53		BIAS <BLUE>	1023	200	107		FACTORY SET FLAG	1	0
54		GAIN <RED>	1023	800					

Table 3-1-2 SERVICE MAP I (2)

Model Name	Component level	NTSC Set-up level	Model
PVM-20M2MDU	1	1	0
PVM-20M2MDE	2	0	2
PVM-20M2MDA	2	0	3
PVM-14M2MDU	1	1	4
PVM-14M2MDE	2	0	6
PVM-14M2MDA	2	0	7

2. SERVICE MAP II

Table 3-1-3 SERVICE MAP II

	SERVICE ITEM	MAX	STD	
			14inch	20inch
1	W/B NTSC R-Y	255	174	171
2	W/B NTSC B-Y	255	161	158
3	W/B PAL R-Y	255	176	180
4	W/B PAL B-Y	255	160	158
5	W/B COMPONENT A R-Y	255	161	174
6	W/B COMPONENT A B-Y	255	156	178
7	W/B COMPONENT B R-Y	255	161	174
8	W/B COMPONENT B B-Y	255	156	178
9	W/B RGB A R-Y	255	114	127
10	W/B RGB A B-Y	255	131	134
11	W/B RGB B R-Y	255	114	127
12	W/B RGB B B-Y	255	131	134
13	LINE A CONTRAST	100	50	50
14	LINE A BRIGHT	100	50	50
15	LINE B CONTRAST	100	50	50
16	LINE B BRIGHT	100	50	50
17	RGB A CONTRAST	100	50	50
18	RGB A BRIGHT	100	50	50
19	RGB B CONTRAST	100	50	50
20	RGB B BRIGHT	100	50	50

3-2. PREPARATION (2). INITIALIZATION

* Supply composite video or component signals as shown in Table 3-2.

Table 3-2

Signal		Details of signal	Standard level P-W
Composite video	358NT	100% white	0.714V
		75% white	0.536V
	PAL	100% white	0.7V
		75% white	0.525V
Component	BETA0	100% white Y	0.7V
		75% white Y	0.525V
		75% color B-Y, R-Y (P-P for this item only)	0.7V
	SMPTE	100% white Y	0.7V
		75% white Y	0.525V
		75% color B-Y, R-Y (P-P for this item only)	0.525V
Voice/sound		-5dBs	0.436Vrms

* In this chapter, indicates the control items in the service mode.

Example: 60 H-FREQ

* Before turning off the power after adjustment in the service mode, write the adjustment data. When the power is turned off before writing, adjusted data will all be lost.

3-3. WRITING MODEL DATA

1. Write model data on respective models in the service mode at the location of No.102 MODEL in accordance with Table 3-3.

Table 3-3

Model	Model data
PVM-20M2MDU	0
PVM-20M2MDE	2
PVM-20M2MDA	3
PVM-14M2MDU	4
PVM-14M2MDE	6
PVM-14M2MDA	7

2. Write the following data in the service mode at the location of No.103 COLOR TEMP DISP 1.

COLOR TEMP DISP 1

65

3. Write the following data in the service mode at the location of No.104 COLOR TEMP DISP 2.

COLOR TEMP DISP 2

56

4. Write the following data in the service mode at the location of No.105 COLOR TEMP DISP 3.

COLOR TEMP DISP 3

93

* Standard inspection state

Unless otherwise specified in this manual, make adjustment under the following conditions:

APERTURE	MIN	(Turn FLAT fully counterclockwise.)
BRIGHT	50%	(Center click)
CHROMA	50%	(Center click)
PHASE	50%	(Center click)
CONTRAST	80%	(Center click)
VOLUME	50%	

3-4. PICTURE OUTPUT

1. AC input voltage setting

1. Input VIDEO signals and AUDIO signals to respective terminals on the connector panel.
2. Set the sliduck AC voltage as shown in Table 3-4.

Table 3-4

Group of models	Voltage
PVM-20M2MDU PVM-14M2MDU	AC 120±3V (Same as above)
PVM-20M2MDE PVM-20M2MDA PVM-14M2MDE PVM-14M2MDA	AC 220±3V (Same as above)

3-5. LANDING ADJUSTMENT

1. CONT ... MAX
BRT ... Conspicuous position
2. Roughly adjust the white balance, G2, and convergence.
3. Switch the rotary SW of the single color switch to change the color into green only.
4. Adjust the purity knob so that the green will come to the center of the screen. Make R and B almost identical. (Fig. 3-1)
5. Switch to B only, R only, and G only and verify each. (Figs.3-1, 3-2, and 3-3)
6. Bring the deflection yoke gradually forward and adjust the deflection yoke so that R and B on both sides of the screen will be green. (Fig.3-2 n Fig. 3-3)
7. If the deflection yoke comes forward too much, the pattern shown in Fig.3-4 will appear. If so, move the deflection yoke backward. (Fig.3-4 n Fig.3-3)
8. Switch the single color switch to B and verify the single color. (Fig.3-6)
9. Switch the single color switch to R and verify the single color. (Fig.3-9)
10. When two colors are mixed, set the mixed color as the standard, and repeat operations 6 and 7.
11. Switch to an all-white signal and check the uniformity.
12. When the deflection yoke position is determined, fasten it with the fixture.

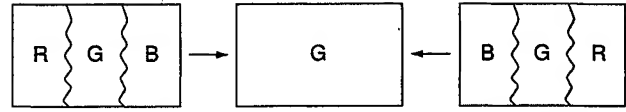
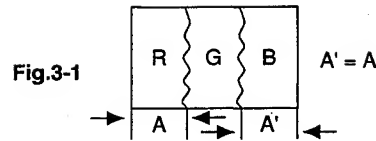

Fig.3-2

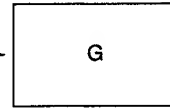

Fig.3-3

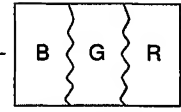

Fig.3-4

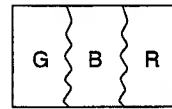

Fig.3-5

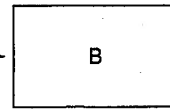

Fig.3-6



Fig.3-7



Fig.3-8



Fig.3-9



Fig.3-10

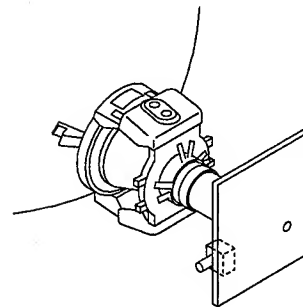

14inch

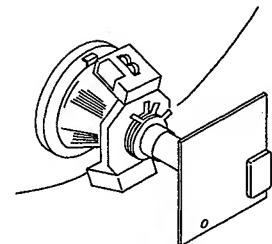

20inch

Fig.3-11

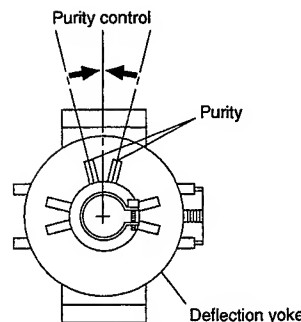

14inch

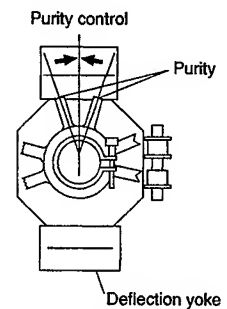

20inch

Fig.3-12

3-6. CONVERGENCE ADJUSTMENT (1)

1. Input a dot pattern signal.
CONT..... Conspicuous position
BRT MIN
2. Align the horizontal R, G, and B dots at the center of the screen with the H-START VR.
- * When H-CENT is changed after H-STAT adjustment, re-adjust H-STAT. (H-STAT will change by means of H-CENT VR.)
3. Align the vertical location of R, G, and B in the center of the screen with the V-STAT Mg. (Fig.3-13, 3-14)
- * After V-STAT adjustment, paint-lock the knob.

V-STAT Mg knob

While keeping the angles A and B equal ($I = I'$), align the vertical convergence.

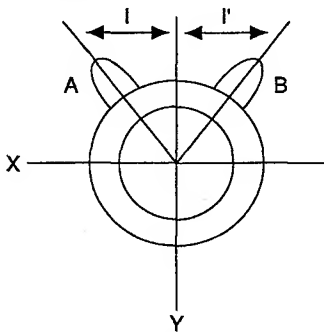

Fig. 3-13 Good example

If the A and B knobs are not symmetrical ($I \neq I'$), the focus may deteriorate, beam striking or other adverse effects may occur.

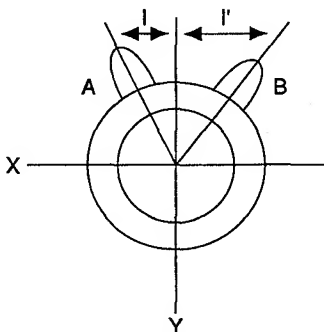
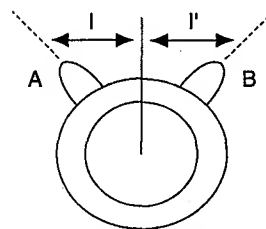

Fig. 3-14 Bad example

4. For HMC, use the BMC Mg to adjust the R and B dots so that they will be symmetrical horizontally with respect to the G dot.



6-pole magnet

Change the opening degree of the BMC Mg to control the HMC.

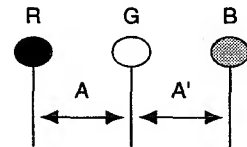

Control the BMC Mg so that $A=A'$. Maintain $I=I'$ when moving the Mg.

Fig. 3-15

5. For VMC, use the MBC Mg to adjust the R and B dots so that they will be symmetrical vertically with respect to the G dot.

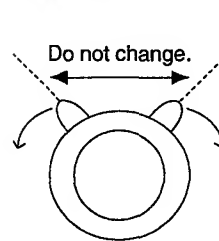

6-pole Mg

For VMC control, turn knob to the right or left without changing their opening degree of the BMC Mg.

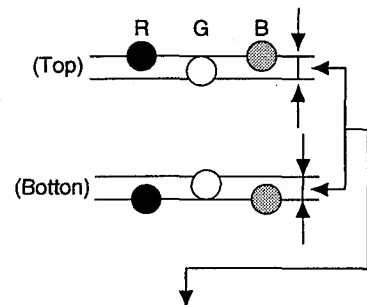

Make adjustment so that the gap will be the same at the top and bottom.

Fig. 3-16

6. Repeat adjustments 2. to 5.
- * The above adjustment may affect the landing, so after adjustment, check the landing again.
7. Paint-lock the knobs after adjustment.

3-7. DEFLECTION YOKE NECK ROTATION ADJUSTMENT

1. If there is nonconvergence on both sides of the X or Y axis of the screen, turn the neck of the deflection yoke in the direction of the arrow to hold the nonconvergence for the entire CRT screen within the tolerance.

- (1) Reverse cross misconvergence pattern (2) Regular cross misconvergence pattern

Move the deflection yoke downward.

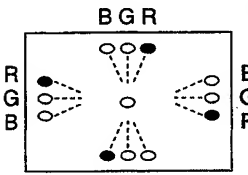

Fig. 3-17

Move the deflection yoke upward.

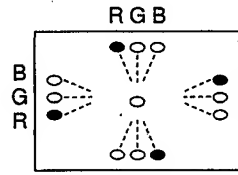

Fig. 3-18

- (3) Pattern of left-sided deflection yoke

Move the deflection yoke to the right when viewed from the CRT screen.

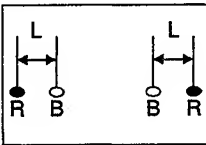

Fig. 3-19

- (4) Pattern of right-sided deflection yoke

Move the deflection yoke to the left when viewed from the CRT screen.

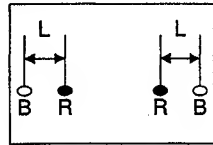

Fig. 3-20

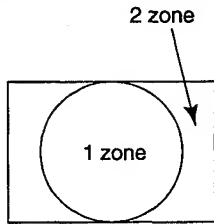

Fig. 3-21

2. Insert the wedge between the deflection yoke and CRT funnel to lock the deflection yoke. (Fig.3-22)



Fig. 3-22

3. The following patterns cannot be corrected by turning the neck. (Figs.3-23, 3-24, and 3-25)

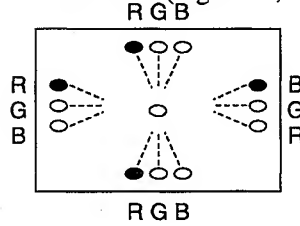

* Gun rotation

The X-axis and Y-axis beams are distorted on both sides.

Fig. 3-23

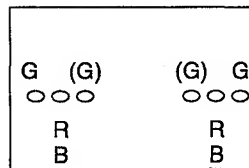

* HCR Large (Small)

The horizontal portion of the G raster is wider (narrower) than that of the RB raster on both sides of the screen.

Fig. 3-24

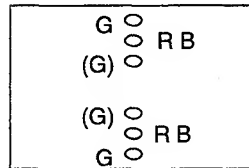

* VCR Large (Small)

The vertical portion of the G raster is wider (narrower) than that of the RB raster on both sides of the screen.

Fig. 3-25

3-8. CONVERGENCE ADJUSTMENT (2)

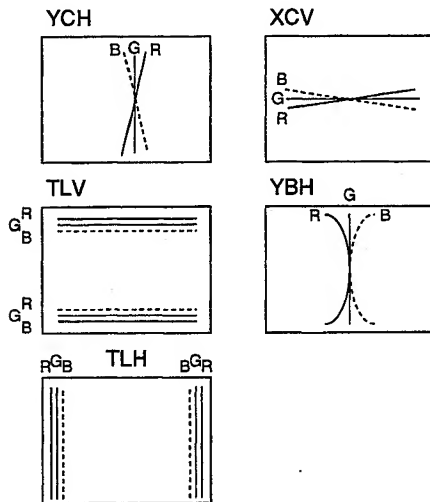

Fig. 3-26 Convergence compensation VR,coil, and compensator

Note : When adjustment is insufficient, use permalloy for perfect adjustment.

1. 14 inch Models

1. Input a cross-hatch signal.
2. Make adjustment with the TLV, YCH VR, and XCV coils of the deflection yoke to minimize nonconvergence.
3. When the nonconvergence of the TILT component is included in the horizontal convergence, insert the TLH compensator into the deflection yoke for adjustment. (Fig.3-26)

2. 20 inch Models

1. Input a cross-hatch signal.
2. Make adjustment with the XCV coil of the deflection yoke to minimize nonconvergence.
3. When the nonconvergence of the TILT component is included in the vertical convergence, insert the TLV compensator into the deflection yoke for adjustment. (Fig.3-26)

3-9. G2 ADJUSTMENT

1. Input a 525 monoscope signal.
2. Connect the probe of the oscilloscope to TP403 on the A board.
3. Measure the lowest reference pulse of the three.
4. Make adjustment with SCREEN VR so that the left end of the waveform will be $1.35V \pm 0.05V$.

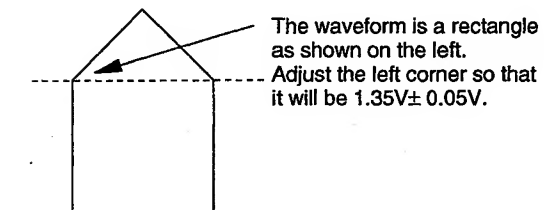
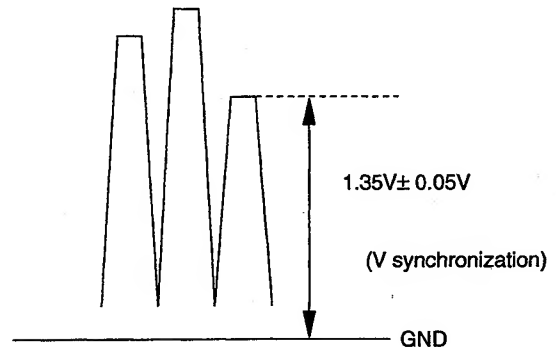

Fig. 3-27

3-10. WHITE BALANCE ADJUSTMENT

1. Input a 525 monoscope signal. (Input from LINE A or B with no burst.)
2. Set as follows:
CONT 0%
BRT 50%
3. Adjust **[SUB-BRIGHT]** in the service mode so that the 20-tone gray scale will be as follows:
0 and 5 IRE → Cut off
10 IRE → Slight glow
4. Input 525 all-white (COMPOSITE signal without burst).
5. Set CONT VR to 80%.
6. Adjust the all-white luminance so that the screen luminance will be 3 NIT.
7. Press MENU and select COL TEMP SELECT.
8. Select 6500K.
Set **[3200K SW]** to "0" for both T1, T2 and T3.
9. Put the unit into the service mode.
10. Adjust to the standard values with <RED> and <BLUE> of **[CT1 6500K BIAS]** . (Refer to NOTE:)
11. Switch the all-white signal luminance to 100 IRE.
12. Adjust to the standard values with <RED> and <BLUE> of **[CT1 6500K GAIN]** . (Refer to NOTE:)
13. Repeat adjustment (10, 11, and 12) until the adjustment is complete, and then write the adjustment data.
14. Press MENU and select COL TEMP SELECT.
15. Select 5600K.
16. Adjust **[CT2 5600K BIAS]** **[CT2 5600K GAIN]** in the same manner as adjustments 10. to 13..
17. The adjustment is complete, and then write the adjustment data.
18. Press MENU and select COL TEMP SELECT.
19. Select 9300K.
20. Adjust **[CT3 9300K BIAS]** **[CT3 9300K GAIN]** in the same manner as adjustments 10. to 13.. (Refer to NOTE:)
21. The adjustment is complete, and then write the adjustment data.

NOTE : Set cut-off to 3NIT.

Fix as follows : <GREEN>

BIAS GREEN ... "300"

GAIN GREEN ... "700"

<Standard Values>

COL TEMP 1 ... 6500K + 8MPCD

COL TEMP 2 ... 5600K + 8MPCD

COL TEMP 3 ... 9300K + 8MPCD

3-11. SUB BRT ADJUSTMENT

1. Input a 525 monoscope signal.
2. Set as follows :
CONT.... Min
BRT 50%
3. Select **[SUB BRIGHT]** in the service mode.
4. Adjust **[SUB BRIGHT]** so that 10 IRE glows slightly and 0 IRE is cut off.

3-12. FOCUS ADJUSTMENT

1. 20 inch Models

1. Input a 525 monoscope signal.
2. Adjust the focus to optimize the focus on the characters "30" at the center of the screen with FOCUS PACK VR.
3. Switch to an all-white signal and check the uniformity.
4. After focus adjustment, paint-lock the FOCUS PACK VR knob.

2. 14 inch Models

1. Input a 525 dot signal.
2. Make adjustment so that the center dot and center of the dots on both sides are not separated with using RV707 on C board.
3. Check that the resolution is more than 600 lines by means of a digital monoscope signal.
4. Change an all-white signal, and check that the magenta ring is un conspicuous by means.

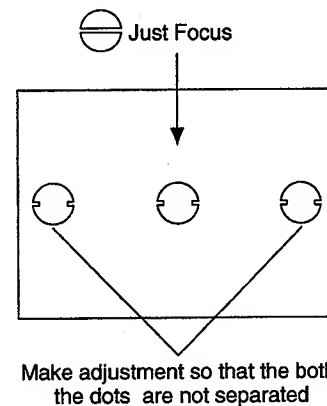

Fig. 3-28

SECTION 4

SAFETY RELATED ADJUSTMENT

When the parts (with a \boxtimes , \boxdot mark on the circuit diagram) shown below are replaced, confirm the matters described in items 4-1 and 4-2 shown below.

- \boxtimes R1536
- \boxdot R551, R506, R519, R518, R516, R515, R508, R517, R1536, R1560, R1537, C549, C512, C513, C523, C592, D501, D533, Q500, Q511, IC500, and IC507

When the following parts are replaced, check the +B voltage: IC600, IC602, D610, C615, C631, C621, C632, and T603

Confirmation procedure

1. Input 120 VAC.
2. Input a monoscope signal, and minimize CONTRAST and BRIGHT.
3. Check that the voltage of the CN605 ① pin is 115.7 VDC.

4-1. CONFIRMATION OF +B MAXIMUM

Standard : Less than 115.7 VDC (CN605 pin ①)
Check Condition Input voltage : 130 VAC

Note : Use NF Power Supply or make sure that distortion factor is 3% or less.

Input signal : Monoscope
Controls : BRT & CONT → Normal

4-2. CONFIRMATION OF HOLD-DOWN CIRCUIT

Check Condition Input voltage : 130 VAC
Input signal : White & Dot
Controls : BRT & Cont → Max. & Min.

4-2-1. Hold-Down Circuit (+B)

- a) Adjust the beam current to $1000 \pm 50 \mu\text{A}$ (20 inch), $600 \pm 50 \mu\text{A}$ (14 inch) with the pin ④ of CN605 with the external DC power supply (less than 130.0 VDC (20 inch), 127.0 VDC (14 inch)) to the point just before the hold-down circuit works.
Input Signal : White
- b) Adjust the beam current to $100 \pm 20 \mu\text{A}$ (20 inch), $80 \pm 20 \mu\text{A}$ (14 inch) with the pin ④ of CN605 with the external DC power supply (less than 131.0 VDC (20 inch), 127.0 VDC (14 inch)) to the point just before the hold-down circuit works.
Input Signal : Dot

4-2-2. Hold-Down Circuit (3rd Wire voltage of FBT)

- Check item : Check of pin ⑪ of IC500 voltage : more than 110.0 VDC
- a) Adjust the beam current to $1000 \pm 50 \mu\text{A}$ (20 inch), $600 \pm 50 \mu\text{A}$ (14 inch) with the pin ⑪ of IC500 with the external DC power supply (less than 141.0 VDC) to the point just before the hold-down circuit works.
Input Signal : White
 - b) Adjust the beam current to $100 \pm 20 \mu\text{A}$ (20 inch), $80 \pm 20 \mu\text{A}$ (14 inch) with the pin ⑪ of IC500 with the external DC power supply (less than 143.0 VDC (20 inch), 141.0 VDC (14 inch)) to the point just before the hold-down circuit works.
Input Signal : Dot

G board

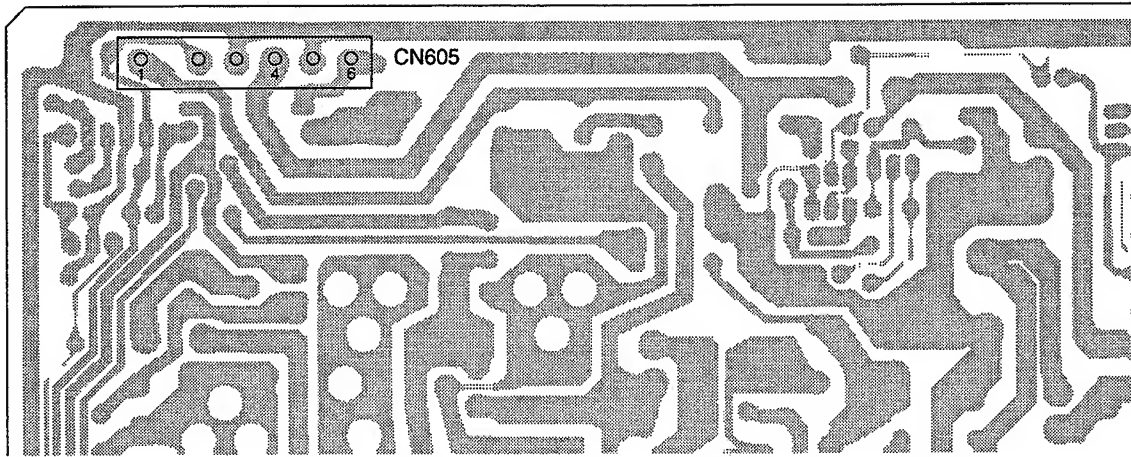

A board (A side)

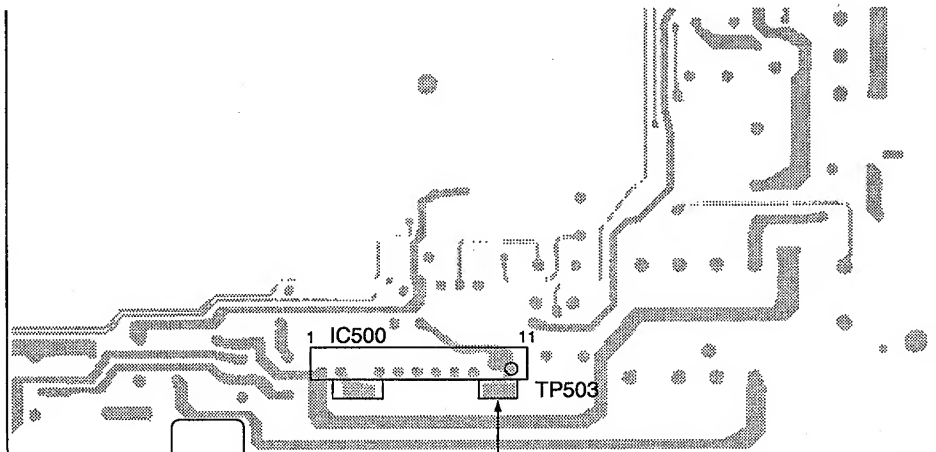

dijital multimeter

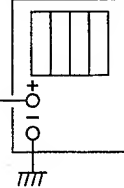

A board (B side)

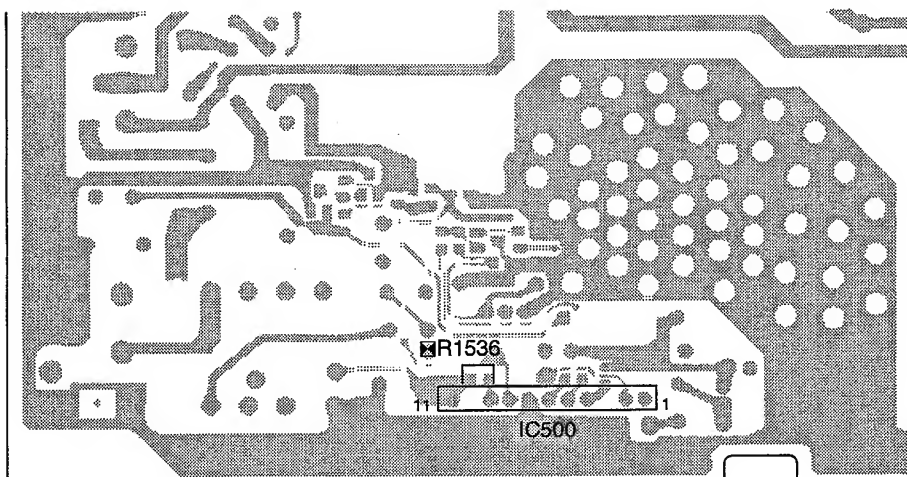

SECTION 5 CIRCUIT ADJUSTMENTS

5-1. A BOARD ADJUSTMENT

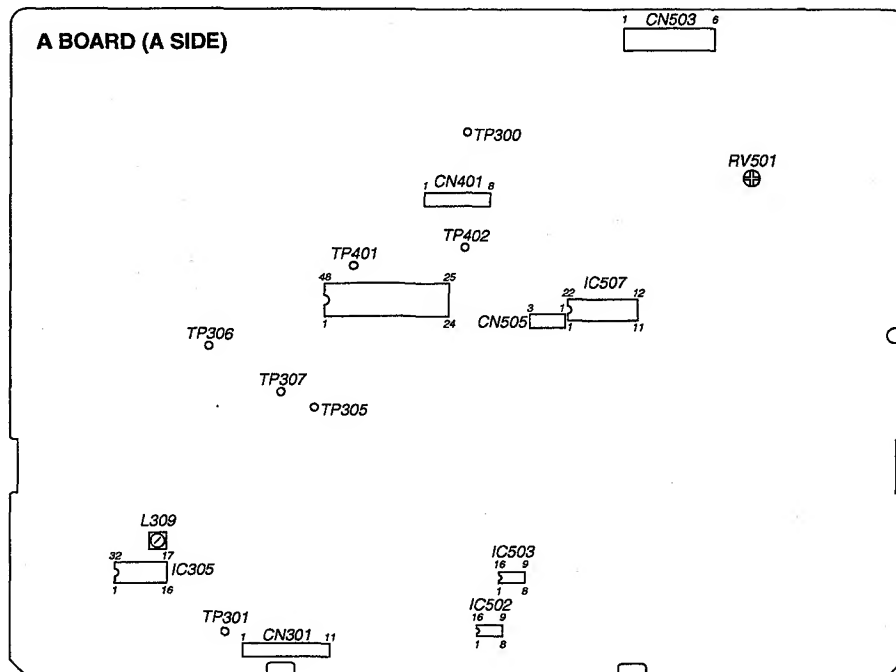

1. PREPARATION/SIGNAL SPECIFICATIONS

1. Signal specifications

* Supply a composite video or component signals from the CN301 connector. Refer to Table 5-1 to take into consideration the effect on the Q board.

The level of the signal to supply should equal to values shown in Table 5-1 plus/minus 2% max.

Table 5-1

Signal		Details of signal	Standard level (Pedestal white)	Reduction rate %	Connector supply level (P-W)
Composite video (75% color bar)	358NT	100% white	0.714V	93%	0.664V
		75% white	0.536V	93%	0.498V
		Burst (Green section) (P-P for this item only)	286mV (632mV)	94% (94%)	269mV (594mV)
	PAL	100% white	0.7V	94%	0.651V
75% white		0.525V	94%	0.488V	
PAL burst (Green section) (P-P for this item only)		300mV (664mV)	94% (94%)	282mV (624mV)	
Component (75% color bar)	BETA 0	100% white	0.7V	94.8%	0.664V
		75% white	0.525	94.8%	0.498V
	SMPTE	75% color B-Y, R-Y (P-P for this item only)	0.7V	94.8%	0.664V
		100% white 75% white 75% color B-Y, R-Y (P-P for this item only)	0.7V 0.525V 0.525	94.8% 94.8% 94.8%	0.664V 0.498V 0.498V

2. Preparation

* In this chapter, indicates the control items in the service mode.

Example: 60 H-FRQ

- Write the applicable model data at the location of NO.102 MODEL in the service mode.

PVM-20M2MDU 0
PVM-20M2MDE 2
PVM-20M2MDA 3
PVM-14M2MDU 4
PVM-14M2MDE 6
PVM-14M2MDA 7

2. ADJUSTMENT OF DEFLECTION SYSTEM

1. Adjustment of horizontal oscillation frequency

1. Input a 525 monoscope signal.
2. Set as follows :
CONT ... 80%
BRT 50%
3. Set the unit in the service mode.
4. Connect the IC507 ①PIN on the A board to GND via the 100 μ /16V chemical capacitor. (Use CN505③PIN for GND.) Or insert the H-FREQ jig into CN505.

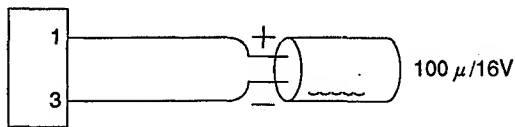

Fig.5-1 H-FREQ jig

5. Adjust 60H-FREQ so that the slanting lines on the screen will be vertical. (Fig.5-2)
6. Input a 625 monoscope signal.
7. Adjust 50H-FREQ so that the slanting lines on the screen will be vertical. (Fig.5-2)

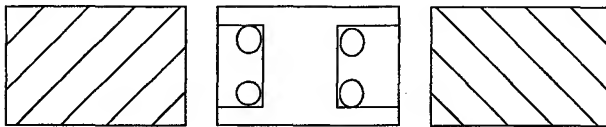

Fig.5-2

2. H BLANKING adjustment

1. Input a 525 monoscope signal.
2. Set as follows :
CONT ... 80%
BRT 50%
3. Set the unit in the service mode.
4. Observe the anode of TP300 or D516 with an oscilloscope, and adjust H-BLANKING so that the waveform will be as shown in Fig.5-3.

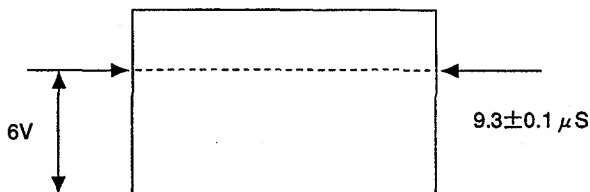

Fig.5-3

3. O/S H BLANKING adjustment

1. Input a 525 monoscope signal.
2. Set the unit in the OVER SCAN mode.
3. Set as follows :
CONT ... 80%
BRT 50%
4. Set the unit in the service mode.
5. Observe the anode of TP307 and TP300 or D516 with an oscilloscope, and adjust O/S H-BLK START and O/S H-BLK END so that the waveform will be as shown in Fig.5-4.

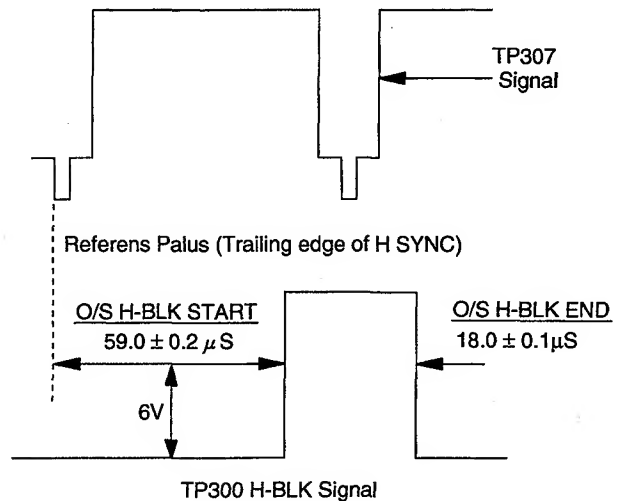

Fig.5-4

4. Picture phase adjustment

1. Input a 525 monoscope signal.
2. Set the unit in the UNDER SCAN mode.
3. Set as follows :
CONT ... Min.
BRT Max.
4. Set the unit in the service mode.
5. Adjust **[USH SIZE]** so that the white frame of the monoscope will be approx. 1 cm to the inside of the effective screen.
6. Turn RV501 (H-CENT) so that $B = B'$.
7. Adjust **[60 VIDEO PHASE]** so that the signal area will be in the center ($A = A'$) of the deflection area. (Fig.5-5)
8. Input a 625 monoscope signal.
9. Adjust **[50 VIDEO PHASE]** in the same manner.

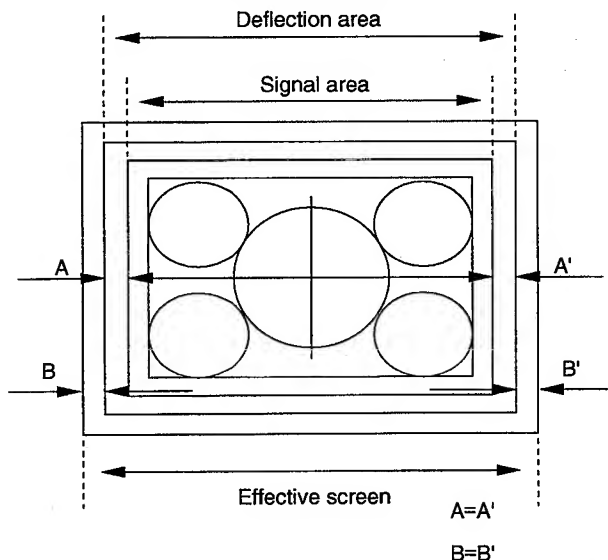

Fig.5-5

5. V BLANKING adjustment

1. Input a 525 monoscope signal.
2. Set the unit in the UNDER SCAN mode.
3. Set as follows :
CONT ... Min.
BRT ... Max.
4. Set the unit in the service mode.
5. Adjust **[V-BLANKING <60>]** so that the white frame in the upper section of the monoscope will be about to be blanked.

Note : Blanking up to the point 1H away from the white frame is permissible, but the adjusting center should be up to the point 0.5H away from the frame.

6. Input a 625 monoscope signal.
7. In the same way as 5. shown above, adjust **[V-BLANKING <50>]**.

6. Vertical deflection adjustment

1. Input a 525 monoscope signal.
2. Set as follows :
CONT 80%
BRT 50%
3. Set the unit in the service mode.
4. Roughly adjust **[NOR 60 V.SIZE]** so that the size will be 12 frames.
Adjust V.LIN with **[V.LIN]**.
Adjust CENT with **[V.CENT]**.
V.CENT must be reviewed after adjustment of V.LIN.
Adjust **[NOR 60 V.SIZE]** so that it will equal the standard value.
5. Input a 625 signal.
6. Adjust **[NOR 50 V.SIZE]** so that the SIZE will equal the standard value.

Table 5-2 NORMAL V. SIZE standard

	525	625
4 : 3	11.75±0.2 frames	11.2±0.2 frames

7. Horizontal deflection adjustment (Normal scan adjustment)

1. Input a 525 monoscope signal.
2. Set as follows :
CONT ... 80%
BRT 50%
3. Set the unit in the service mode.
4. Rough adjustment of H.SIZE
Roughly adjust **[NOR H.SIZE]** so that H.SIZE will be 15.75 frames.
5. Adjust the horizontal deflection by means of **[NOR PIN AMP]**, **[NOR PIN PHASE]**, **[NOR U.PIN AMP]**, **[SEXY]**, **[V BOW]**, **[V ANGL]**, **[NOR H SIZE]**, **[L PIN AMP]**, and **[L V BOW]**.
(While correcting a distorted parallelogram and curvature with V.ANGL and BOW, make adjustment so that the horizontal and vertical lines of the screen will be straight.)
6. Input a 625 monoscope signal.
7. Confirm that the screen is normal.

Table 5-3 NORMAL H. SIZE standard

	525	625
4 : 3	15.75±0.2 frames	15.0±0.2 frames

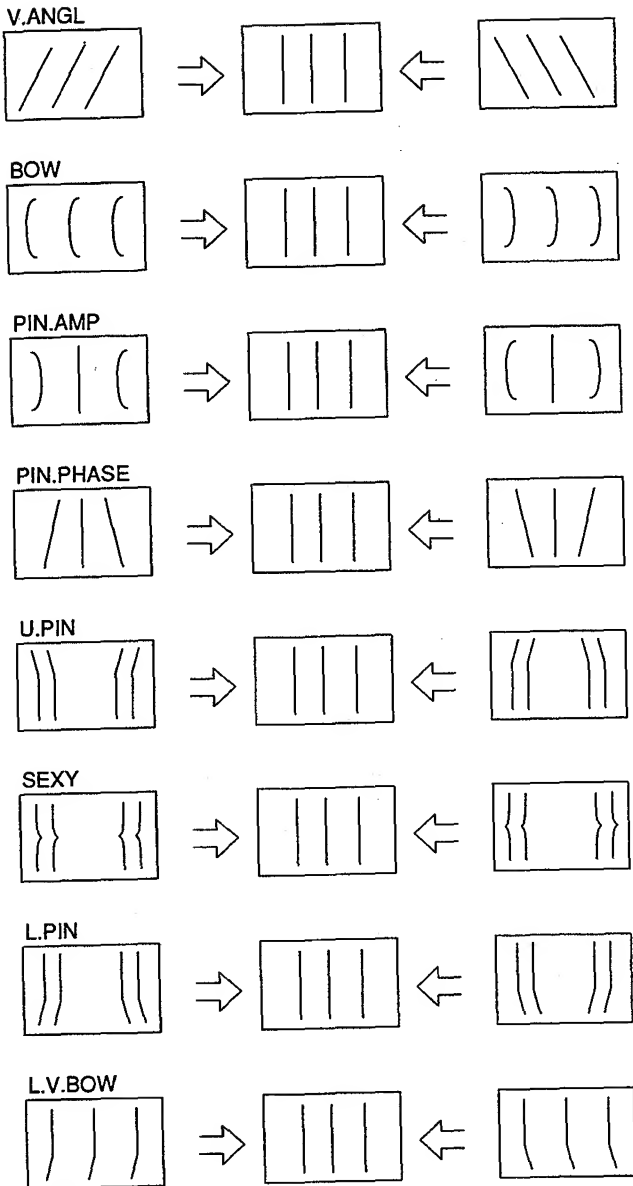

Fig.5-6

8. UNDER SCAN adjustment

1. Input a 525 monoscope signal.
2. Set as follows :
CONT 80%
BRT 50%
3. Set the unit in the U/S mode.
4. Set the unit in the service mode.
5. Adjust **[U/S V SIZE <60>]** so that UNDER V.SIZE will be within the standard.
6. Adjust **[U/S H SIZE]** so that UNDER H.SIZE will be within the standard.
7. Adjust **[U/S PIN AMP]** and **[U/S PIN-PHASE]**. (Adjust tracking according to 5., 6., and 7.)
8. After adjustment, the white frame of the monoscope shall not be out of the effective screen.

9. Input a 625 monoscope signal.

10. Adjust **[U/S V SIZE <50>]** becomes within the standard value.

Table 5-4
Standard values for 14 inch

	525	625
U/S H-SIZE	252 ± 2mm	252 ± 2mm
U/S V-SIZE	188 ± 2mm	188 ± 2mm

Table 5-5
Standard values for 20 inch

	525	625
U/S H-SIZE	364 ± 3mm	364 ± 3mm
U/S V-SIZE	272 ± 3mm	272 ± 3mm

9. OVER SCAN adjustment

1. Input a 525 monoscope signal.
2. Set as follows :
CONT ... 80%
BRT 50%
3. Set the unit in the O/S mode.
4. Set the unit in the service mode.
5. Adjust **[O/S H SIZE]** so that H.SIZE becomes 13.6 frames and **[O/S V SIZE <60>]** so that V.SIZE becomes 10.2 frames.
6. Adjust horizontal deflection section with **[O/S PIN AMP]** and **[O/S PIN PHASE]**.
7. Input a 625 monoscope signal.
8. Adjust **[O/S V SIZE <50>]** becomes within the standard value.

Table 5-6 Standard value

	525	625
O/S H-SIZE	13.6 ± 0.2 frame	13.0 ± 0.2 frame
O/S V-SIZE	10.2 ± 0.2 frame	9.8 ± 0.2 frame

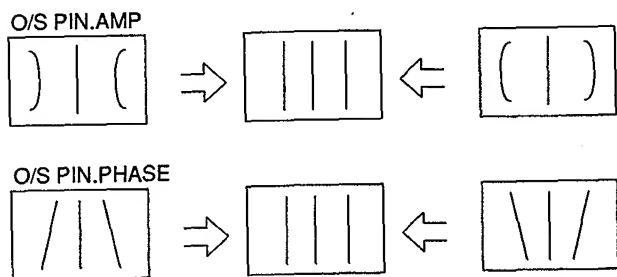

Fig.5-7

10. Writing adjustment results

Write the adjustment results.

Note: Do not turn off the power before writing the adjustment results; otherwise, they will all be lost.

3. Signal system adjustment

1. SUB PHASE adjustment

1. Input a component color bar (R-Y) and EXT SYNC. (BETA 0 level signal)
2. Set the unit in the EXT SYNC mode for component input.
3. Connect the probe of an oscilloscope to IC404 ③⑩ PIN or TP402.
4. Set the unit in the service mode.
5. Adjust **SUB PHASE** so that the output waveform will be minimum (15 mVp-p or less). (Fig.5-8)

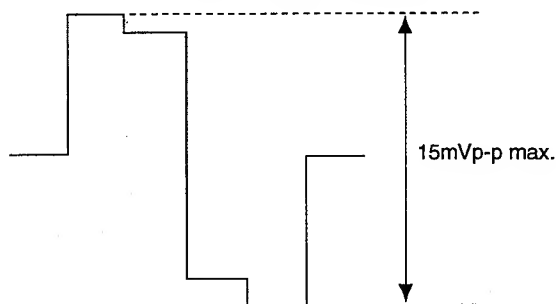
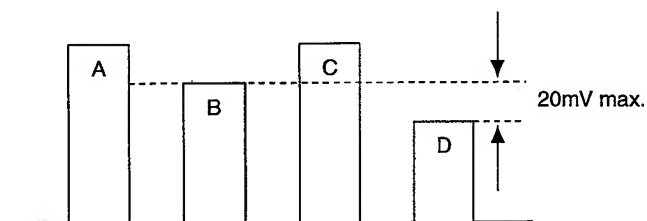

Fig. 5-8

2. SUB CHROMA adjustment

1. Input component color bars (R-Y, Y, and B-Y). (BETA 0 level signal)
2. Set COMPONENT LEVEL to BETA 0 via MENU.
3. Connect the probe of an oscilloscope to IC404 ③⑩ PIN or TP402.
4. Set the unit in the service mode.
5. Adjust **SUB CHROMA NORMAL** so that the peaks of waveforms will be flush with each other as shown in Fig.5-9.



Make B flush with D

Fig. 5-9

3. R-Y LEVEL adjustment

1. Input component color bars (R-Y, Y, and B-Y). (BETA 0 level signal)
2. Set COMPONENT LEVEL to BETA 0 via MENU.
3. Connect the probe of an oscilloscope to IC404 ③⑩ PIN or TP401.
4. Set the unit in the service mode.
5. Adjust **R-Y LEVEL COMPONENT** so that the peaks of waveforms will be flush with each other as shown in Fig.5-10.

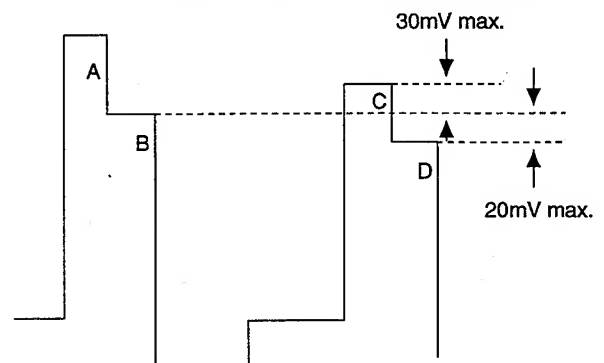

Make adjustment so that B = D as shown above. (20 mV max.)
Check that the difference between B and C is 30 mV or less.

Fig. 5-10

4. SMPTE SUB COL adjustment

1. Input component color bars (R-Y, Y, and B-Y). (SMPTE level signal)
2. Set COMPONENT LEVEL to N10/SMPTE via MENU.
3. Connect the probe of an oscilloscope to IC404 ③⑩ PIN or TP402.
4. Set the unit in the service mode.
5. Adjust **SUB CHROMA SMPTE** so that the levels of B and D will be the same. (Fig.5-11)

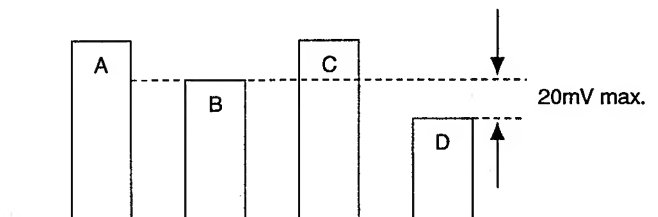

Make B flush with D

Fig. 5-11

5. Adjustment of burst gate pulse width

1. Input an NTSC color bar.
2. Connect the probe of an oscilloscope to TP301 (COMP-SYNC) and Q363 (E) or IC305 ①PIN. (Exercise care since IC305 (1) PIN is a high-impedance line.)
3. Set the unit in the service mode.
4. Adjust **BGP WIDTH** so that the output waveforms will be as shown in Fig.5-12.

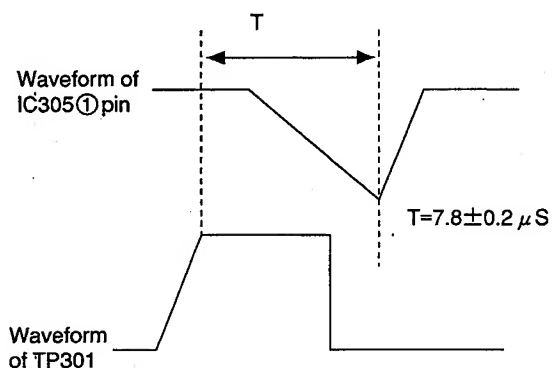

Fig. 5-12

6. VXO adjustment

6-1. X'tal 358

- 1) Input an NTSC color bar.
- 2) Connect a frequency counter to IC305 ②PIN.
- 3) Set the unit in the service mode.
- 4) Connect IC305 ①PIN as shown in Fig.5-13.
- 5) Adjust **NTSC CRYSTAL** so that the counter reading will be within the standard values shown below. (Adjustment may be made at a point at which the color flickering stops.)

X'tal 358 standard value: 3579545±20 Hz

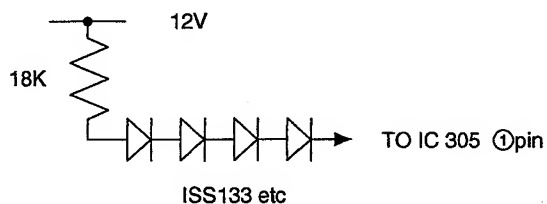

(Arrange four diodes as close as possible to ①PIN at the shortest possible distance.)

Fig. 5-13

6-2. X'tal 443

- 1) Input a PAL color bar.
 - 2) Connect a frequency counter to IC305 ②PIN.
 - 3) Set the unit in the service mode.
 - 4) Connect IC305 ①PIN in the same way as 6-1. 4) in 6. VXO adjustment.
 - 5) Adjust **NTSC 443 CRYSTAL** in the same way as 6-1. 5) in 6. VXO adjustment.
- X'tal 443 standard value: 4433619±20 Hz

7. NTSC . PAL color demodulation adjustment

7-1. NT358PHASE (NORMAL)

- 1) Input an NTSC color bar.
- 2) Connect the probe of an oscilloscope to TP306.
- 3) Set the unit in the service mode.
- 4) Adjust **PHASE NTSC 358 NOR** so that the burst section of the output waveform will be straight. (Fig.5-14)

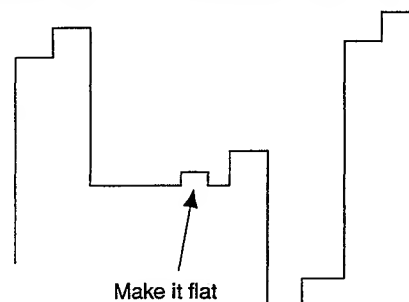

Fig. 5-14

7-2. NT 358 B-Y PHASE

Note : Make adjustment after PHASE adjustment and before CHROMA adjustment.

- 1) Input an NTSC color bar. (Input only the R-Y component. B-Y and Y should be OFF.)
- 2) Connect the probe of an oscilloscope to TP305.
- 3) Set the unit in the service mode.
- 4) Adjust **B-Y PHASE NTSC 358** so that the color components will be straight.

7-3. NT 358 CHROMA (NORMAL)

- 1) Input an NTSC color bar.
- 2) Connect the probe of an oscilloscope to IC404 ③⑨ PIN or TP402.
- 3) Set the unit in the service mode.
- 4) Adjust **CHROMA NTSC 358 NOR** so that the peaks of waveforms will be flush with each other as shown in Fig.5-15.

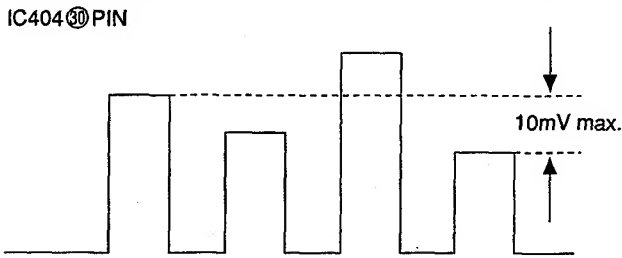

Make adjustment so that the 1st and 4th peaks are at the same level.

Fig. 5-15

7-4. NTSC 358 R-Y LEVEL

- 1) Input an NTSC 358 color bar.
- 2) Connect the probe of an oscilloscope to IC404 ④① PIN or TP401.
- 3) Set the unit in the service mode.
- 4) Adjust **R-Y LEVEL NTSC 358** so that the peaks of waveforms will be flush with each other as shown in Fig.5-16.

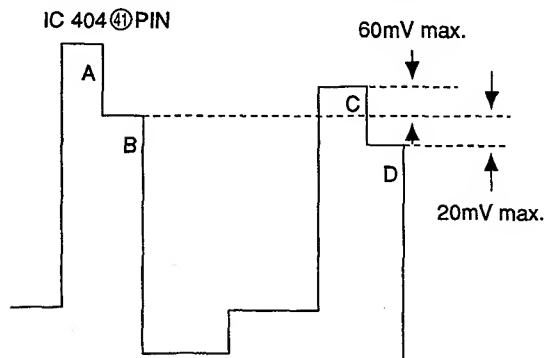

Make adjustment so that B=D as shown above. (20mV max.)
Check that the difference between B and C is less than 60mV.

Fig. 5-16

7-5. PAL PHASE (NORMAL)

- 1) Input a PAL SP color bar.
- 2) Connect the probe of an oscilloscope to TP306.
- 3) Set the unit in the service mode.
- 4) Adjust **PHASE PAL NOR** so that the waveform of the B-Y anti-PAL signal will be "0."

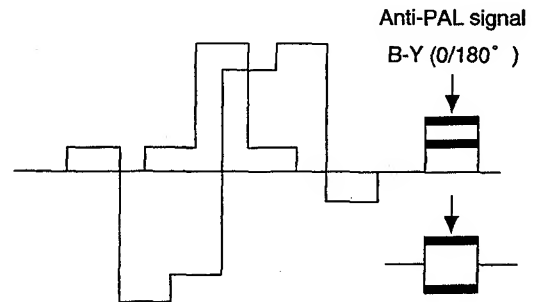

*The signal waveform differs slightly every hour.
Adjust it to "0."

Fig. 5-17 R-Y OUT

7-6. PAL B-Y PHASE

- 1) Input a PAL SP color bar.
- 2) Connect the probe of an oscilloscope to TP305.
- 3) Set the unit in the service mode.
- 4) Adjust **B-Y PHASE PAL** so that the waveform of the R-Y anti-PAL signal will be "0." (Fig.5-18)

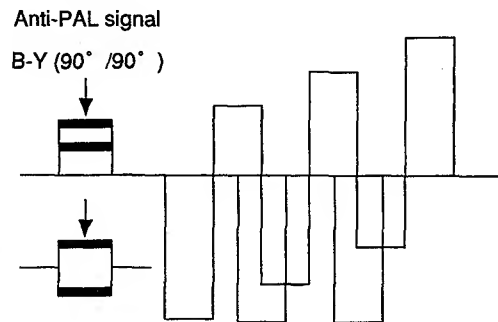

*The signal waveform differs slightly every hour.
Adjust it to "0."

Fig. 5-18 B-Y OUT

7-7. PAL CHROMA (NORMAL)

- 1) Input a PAL color bar.
- 2) Connect the probe of an oscilloscope to IC404 ⑩PIN or TP402.
- 3) Set the unit in the service mode.
- 4) Adjust **CHROMA PAL NOR** so that the peaks of waveforms will be flush with each other. (Fig.5-19)

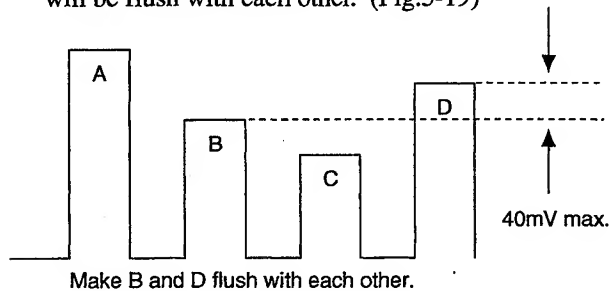

Fig. 5-19

7-8. PAL R-Y LEVEL

Note : Be sure to set ACC in the ON position before this adjustment.

- 1) Input a PAL color bar.
- 2) Connect the probe of an oscilloscope to IC404 ④PIN or TP401.
- 3) Set the unit in the service mode.
- 4) Adjust **R-Y LEVEL PAL** so that the peaks of waveforms will be flush with each other as shown Fig.5-20.

IC404 ④PIN

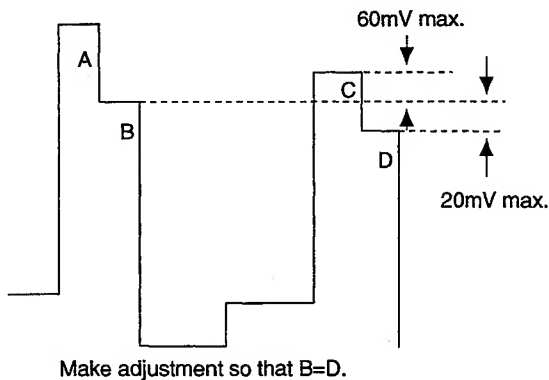

Fig. 5-20

8. W/B plunge correction

8-1. Adjustment of NTSC composite

- 1) Input the 525 all white (with burst) cut-off signal to LINE A.
- 2) Select LINE A input.
- 3) Adjust the brightness becomes 3 cd/m² with CONT and BRT VR.
- 4) Turn CHROMA VR to MIN, and measure the color temperature.
- 5) Turn CHROMA VR to MAX, and make adjustment with **NTSCB-Y** and **NTSCR-Y** so that the color temperature will be the same as the value measured in item 4).
Standard adjustment: The difference should be within 2 JND when CHROMA MIN → MAX .

8-2. Adjustment of PAL composite

- 1) Input the 625 all white (with burst) cut-off signal.
- 2) Repeat the operations 8-1. 2), 3), and 4).
- 3) Turn CHROMA VR to MAX, and make adjustment with **PALB-Y** and **PALR-Y** so that the color temperature will be the same as the value measured in item 4).
Standard adjustment: The difference should be within 2 JND when CHROMA MIN → MAX .

8-3. Adjustment of COMPONENT

- 1) Input the 525 all white cut-off signal to RGB A CH Y. NTSC all white (with burst) may be input.
- 2) Select COMPONENT A CH.
- 3) Repeat the operations 8-1. 3) and 4).
- 4) Turn CHROMA VR to MAX, and make adjustment with **COMPONENT A B-Y** and **COMPONENT A R-Y** so that the color temperature will be the same as the value measured in item 4).
Standard adjustment: The difference should be within 2 JND when CHROMA MIN Æ MAX .
- 5) Input the 525 all white cut-off signal to RGB CH Y. NTSC all white (with burst) may be input.
- 6) Select COMPONENT B CH
- 7) Repeat the operations 8-1. 3) and 4).
- 8) Turn CHROMA VR to MAX, and make adjustment with **COMPONENT B B-Y** and **COMPONENT B R-Y** so that the color temperature will be the same as the value measured in item 4).
Standard adjustment: The difference should be within 2 JND when CHROMA MIN → MAX .

9. Adjustment of SUB CONT

- 1) Input the window signal.
- 2) Enter the Normal mode.
- 3) Attach a luminance meter to the window of the CRT surface.
- 4) Make adjustment so that the values will be as shown in Table 5-7 with **[SUB CON <NORM>]**.
- 5) Enter the O/S mode.
- 6) Make adjustment so that the values will be as shown in Table 5-7 with **[SUB CON <O/S>]**.

Table 5-7 Unit (cd/m²)

	14 inch	20 inch
SUB CON <NORM>	170±20	150±20
SUB CON <O/S>	170±20	150±20

10. Fine adjustment of CONT/BRT level of each input

When the same signal is input to each input terminal, the CONT/BRT level may change slightly. In that case, fine adjustment of CONTRAST/BRIGHTNESS can be made for each input terminal.

11. Writing the result of adjustment

Write the result of adjustment in the memory.

5-2. G AND GA BOARDS ADJUSTMENT

1. Checking the output lines

Checking that the output lines meet the standards below.

G Board	15V	14.7 ± 0.7V
	5V(A)	5.0 ± 0.4V
	- 15V	- 15.9 ± 1.0V
GA Board	8V	8.0 ± 0.3V

SECTION 6 DIAGRAMS

6-1. BLOCK DIAGRAMS

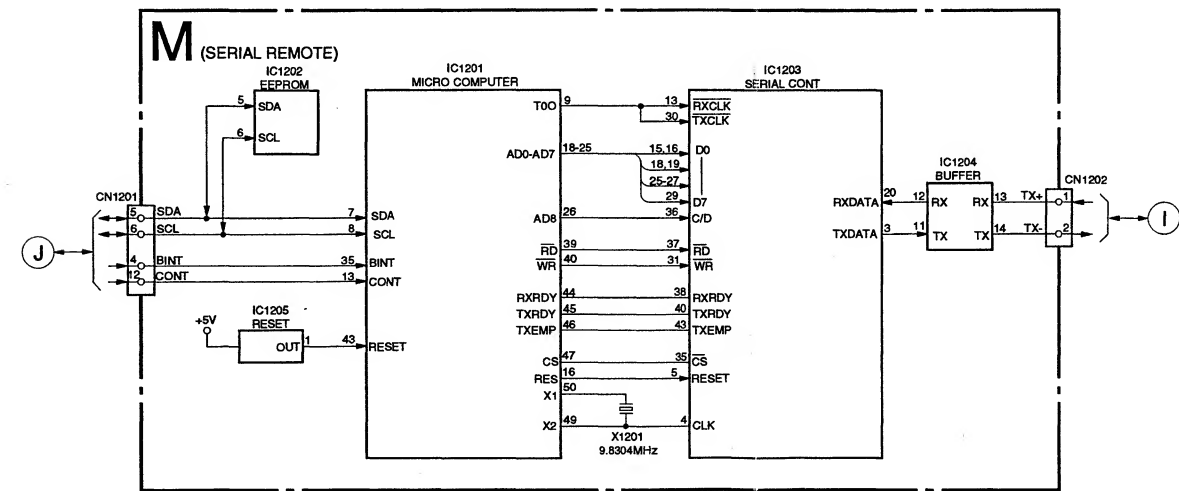
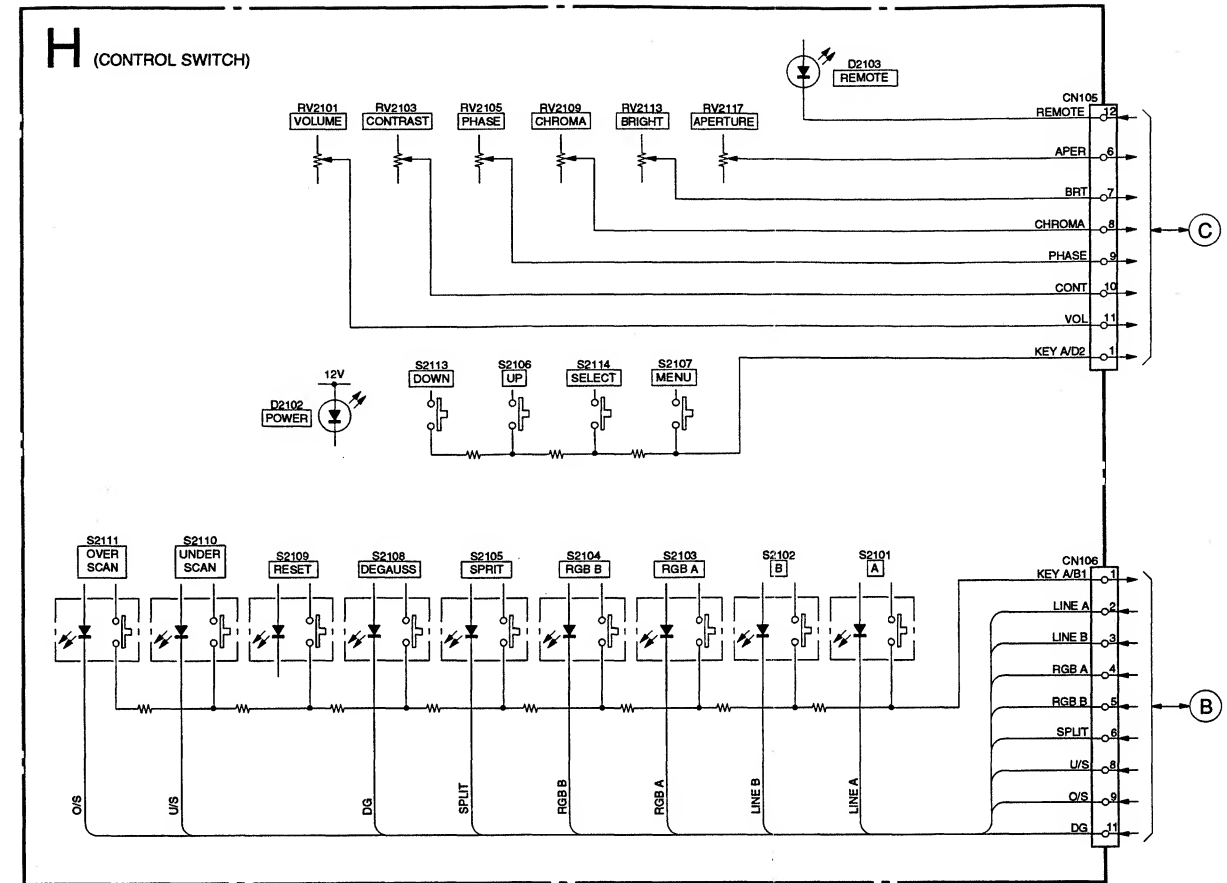
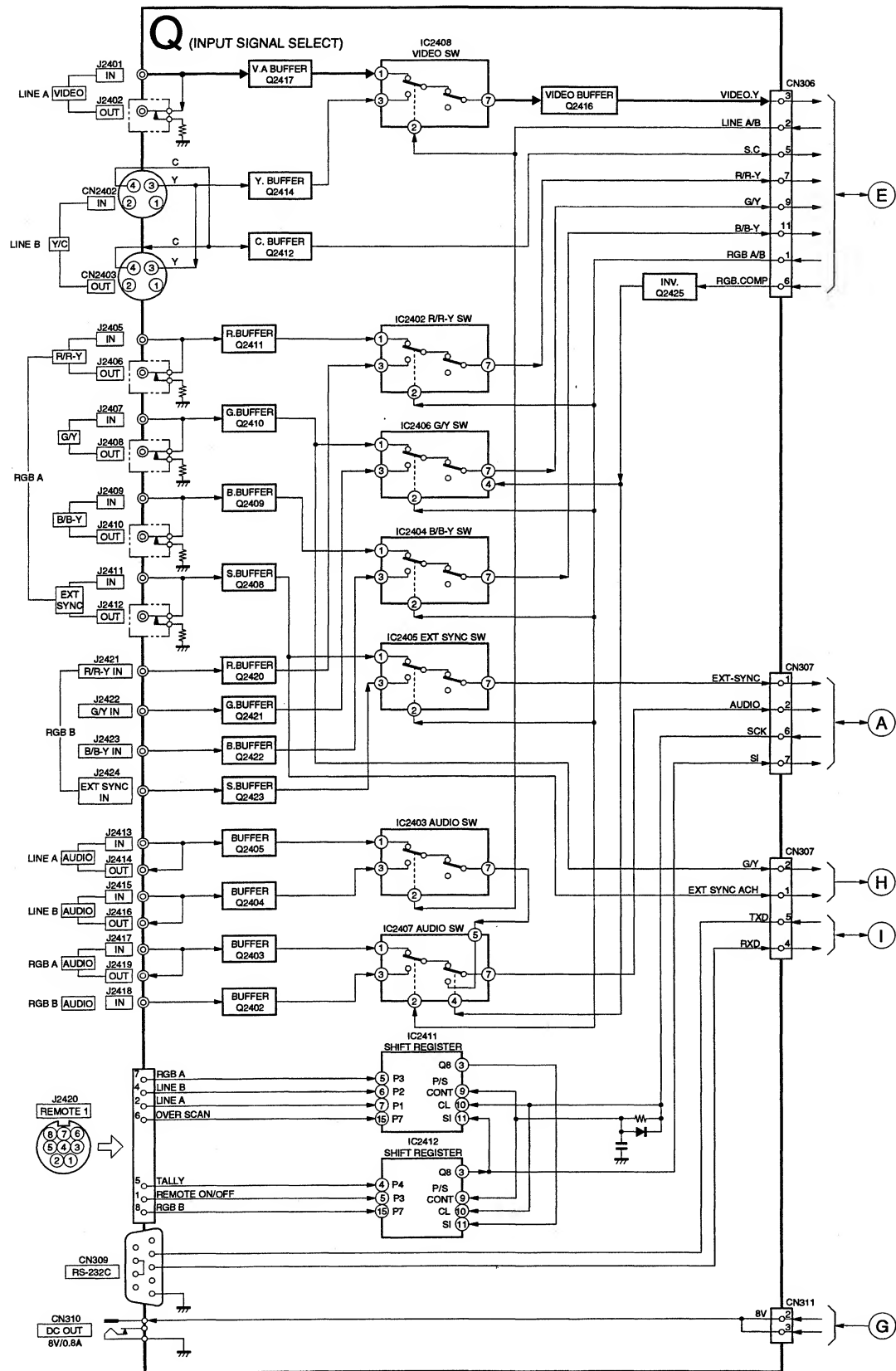

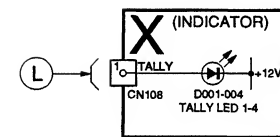
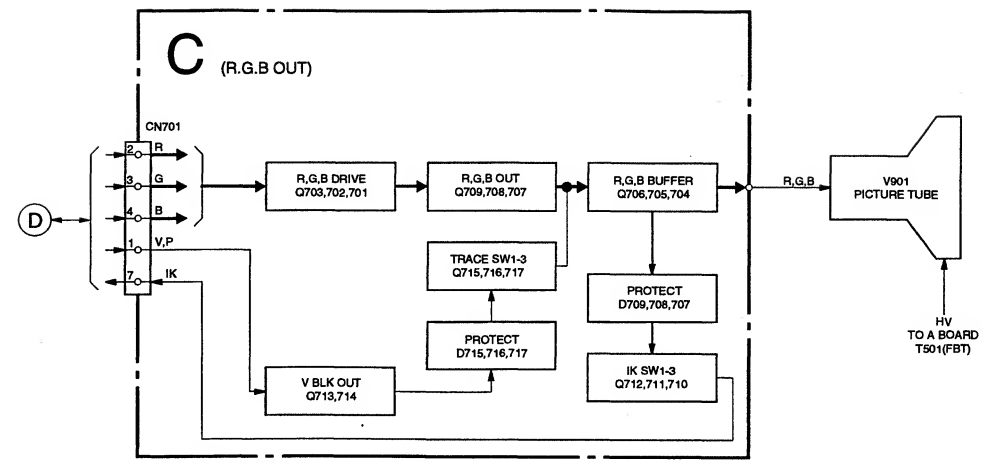
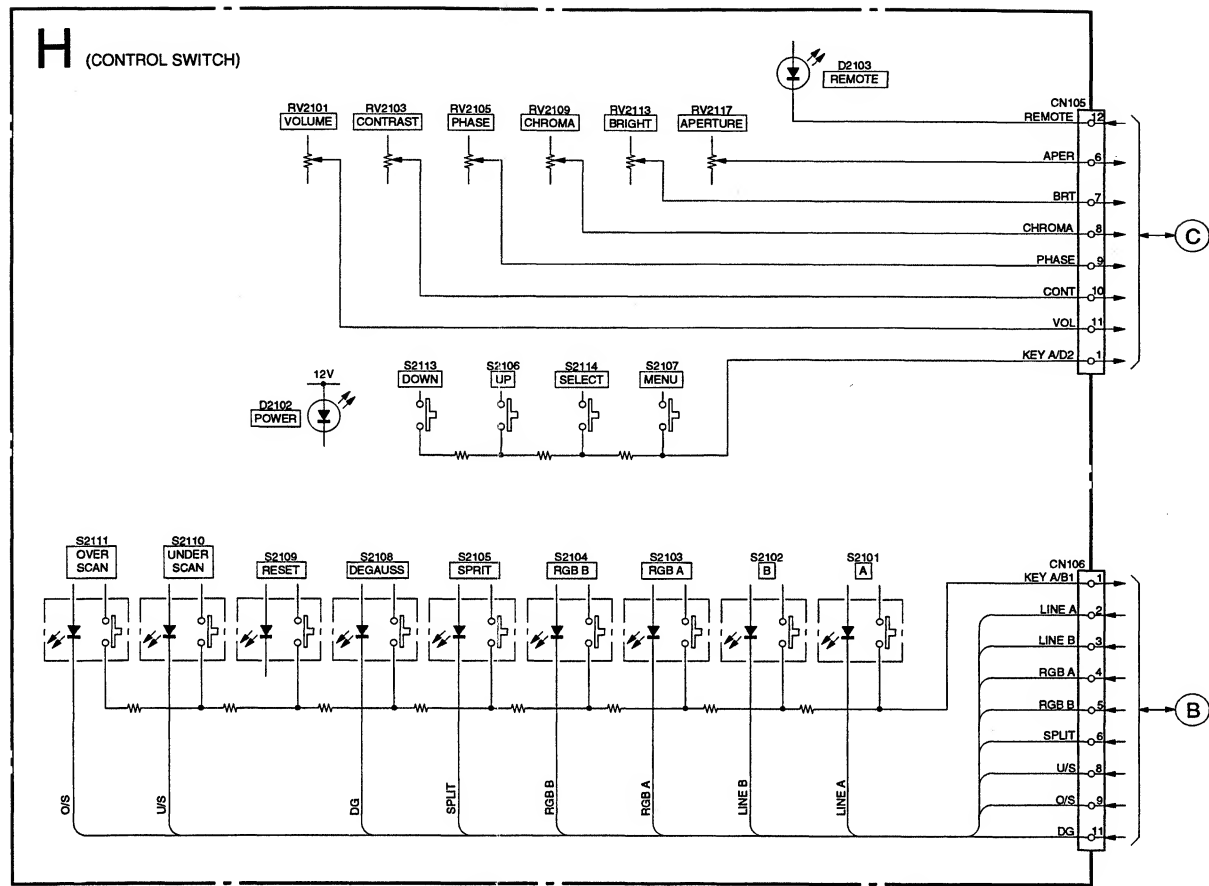

U/C MODEL ONLY

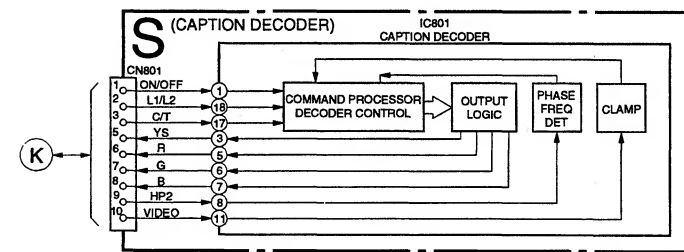
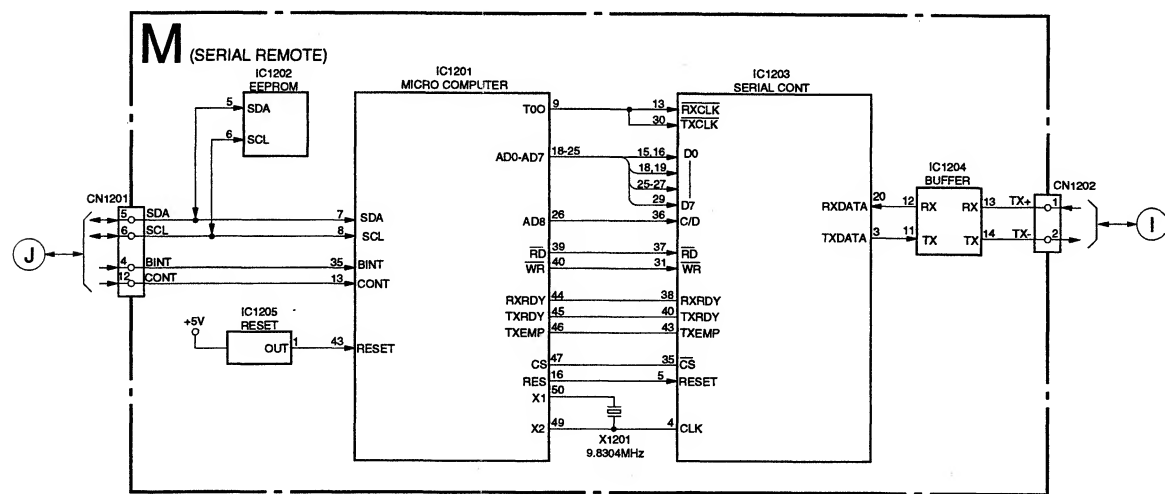

A (VIDEO,AUDIO,DEFLECTION)

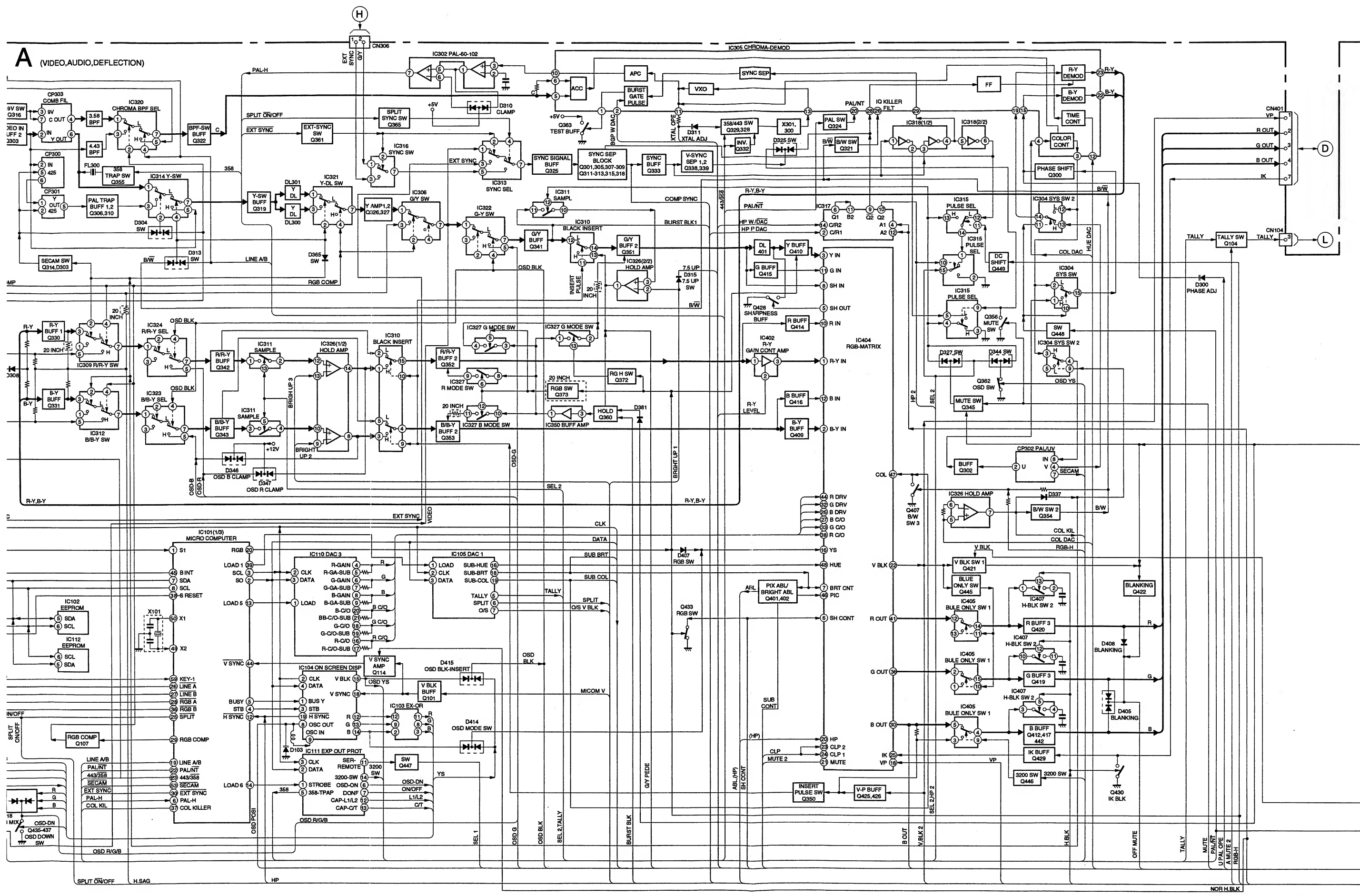

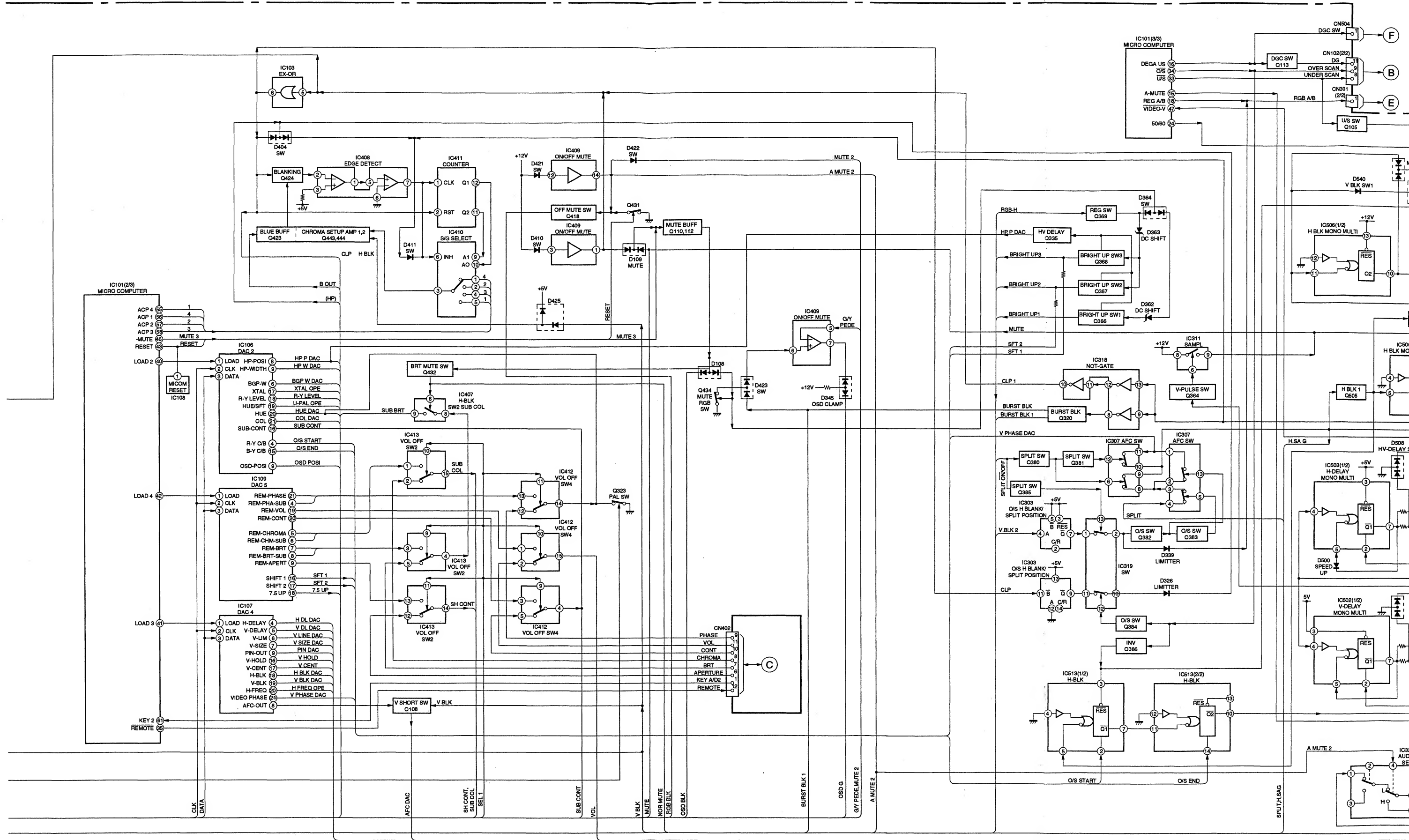

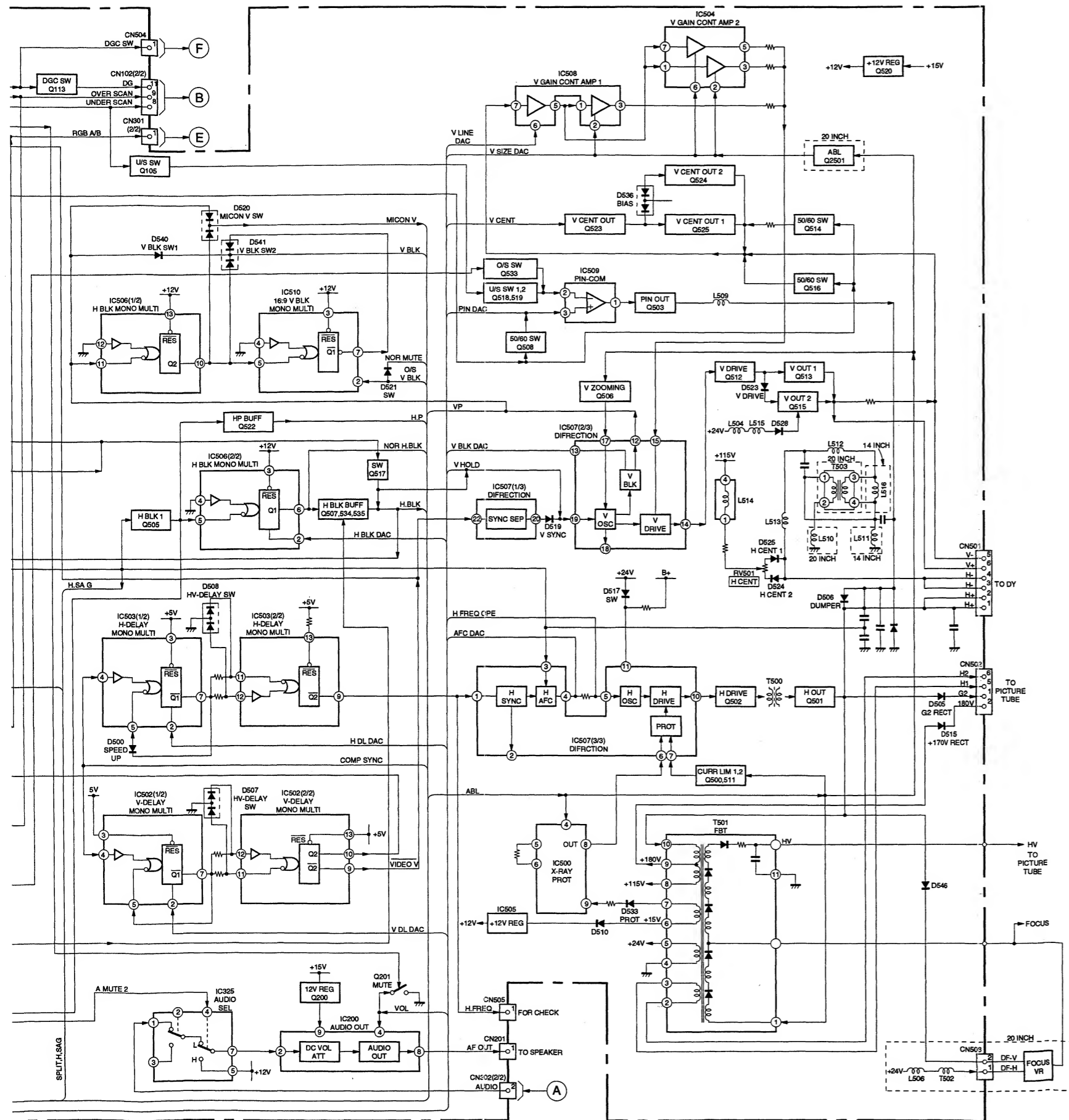

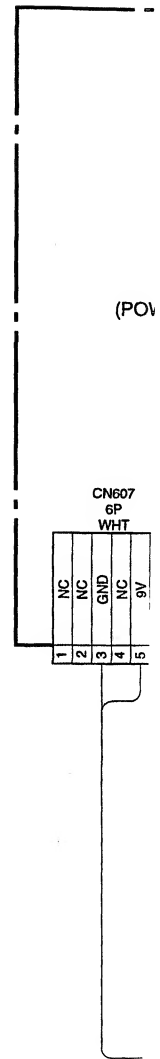
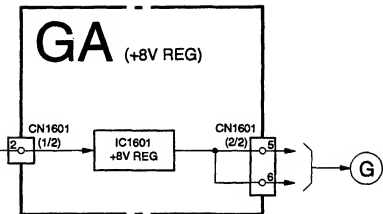
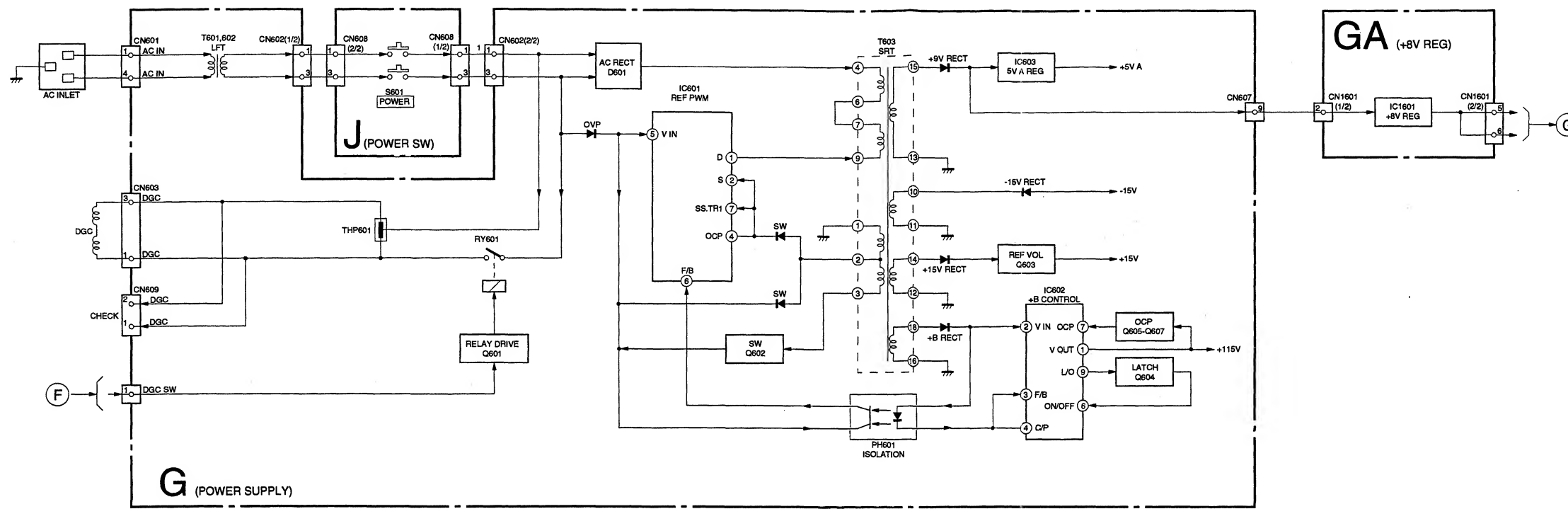

6-2. FRAME SCHEMATIC DIAGRAM

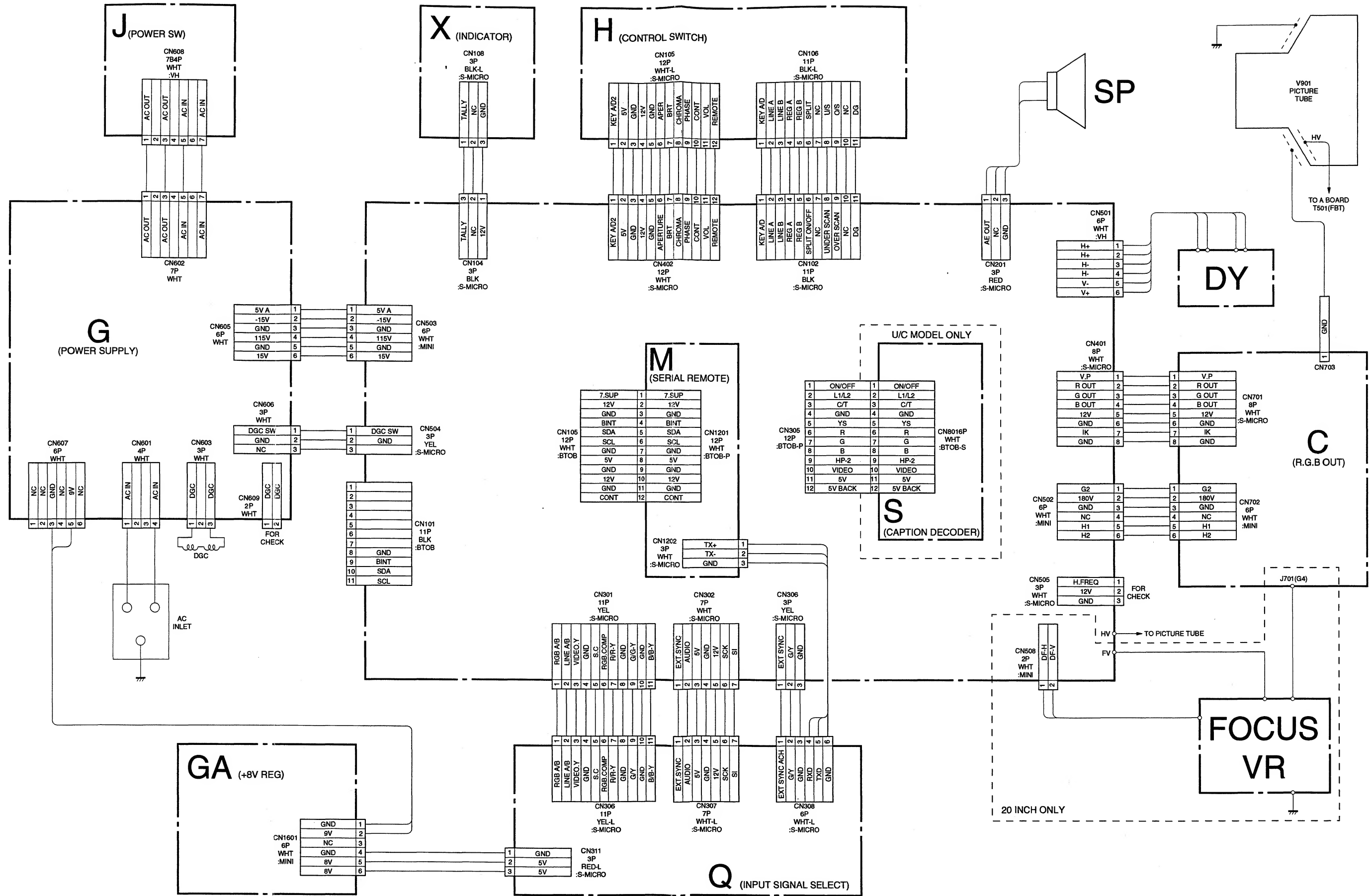



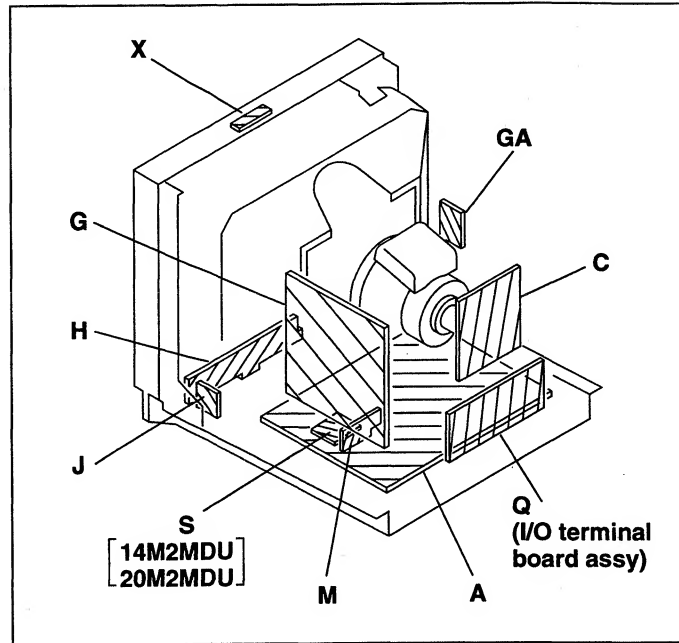





6-3. CIRCUIT BOARDS LOCATION





6-4. SCHEMATIC DIAGRAMS AND PRINTED WIRING BOARDS

Note:

- All capacitors are in μF unless otherwise noted. pF: $\mu\mu\text{F}$
- Capacitors without voltage indication are all 50V.
- All resistors are in ohms, 1/4W in resistance, 1/10W in chip resistance.
k Ω = 1000 Ω , M Ω = 1000k Ω
-  : nonflammable resistor.
-  : fusible resistor.
-  : internal component.
-  : panel designation and adjustment for repair.
- All variable and adjustable resistors have characteristic curve B, unless otherwise noted.
- # marked in these schematic diagrams signifies not mounted.
- The components identified by  in this basic schematic diagram have been carefully factory-selected for each set in order to satisfy regulations regarding X-ray radiation. Should replacement be required, replace only with the value originally used.
- When replacing components identified by , make the necessary adjustments indicated. If results do not meet the specified value, change the component identified by  and repeat the adjustment until the specified value is achieved. (Refer to R1536 adjustment on Page 4-1)
- When replacing the part in below table, be sure to perform the related adjustment.

Part replaced ()	Adjustment ()
C512, C513, C523, C549, C592, D501, D533, IC500, IC507, Q500, Q511, R506, R508, R515, R516, R517, R518, R519, R551, R1536, R1537, R1560 (A BOARD)	R1536 (HOLD-DOWN)

- Voltage value is the reference value between it and the earth, when color bar signal is received from color bar generator (digital multi-meter used : 10M ohms/V DC).
- Unit of voltage values is V (volt).
- No mark : with PAL color-bar signal received or common voltage.
- For the respective voltage ratings in NTSC 3.58, NTSC 4.43, S-VIDEO, and ANALOG RGB modes, see the table.
-  : B + line, B - line. (Actual measured value may be different).
- Circled numbers are waveform references.
-  : Signal Path.

Reference information

RESISTOR	: RN	METAL FILM
	: RC	SOLID
	: FPRD	NONFRAMMABLE CARBON
	: FUSE	NONFLAMMABLE FUSIBLE
	: RS	NONFLAMMABLE METAL OXIDE
	: RB	NONFLAMMABLE CEMENT
	: RW	NONFLAMMABLE WIREWOUND
	: ※	ADJUSTMENT RESISTOR
COIL	: LF-8L	MICRO INDUCTOR
CAPACITOR	: TA	TANTALUM
	: PS	STYROL
	: PP	POLYPROPYLENE
	: PT	MYLAR
	: MPS	METALIZED POLYESTER
	: MPP	METALIZED POLYPROPYLENE
	: ALB	BIPOLAR
	: ALT	HIGH TEMPERATURE
	: ALR	HIGH RIPPLE

Note: The component identified by shading and mark  are critical for safety. Replace only with part number specified.

Note: Les composants identifiés par une trame et une marque  sont critiques pour la sécurité. Ne les remplacer que par une pièce portant le numéro spécifié.

H [CONTROL SWITCH]

- H BOARD -

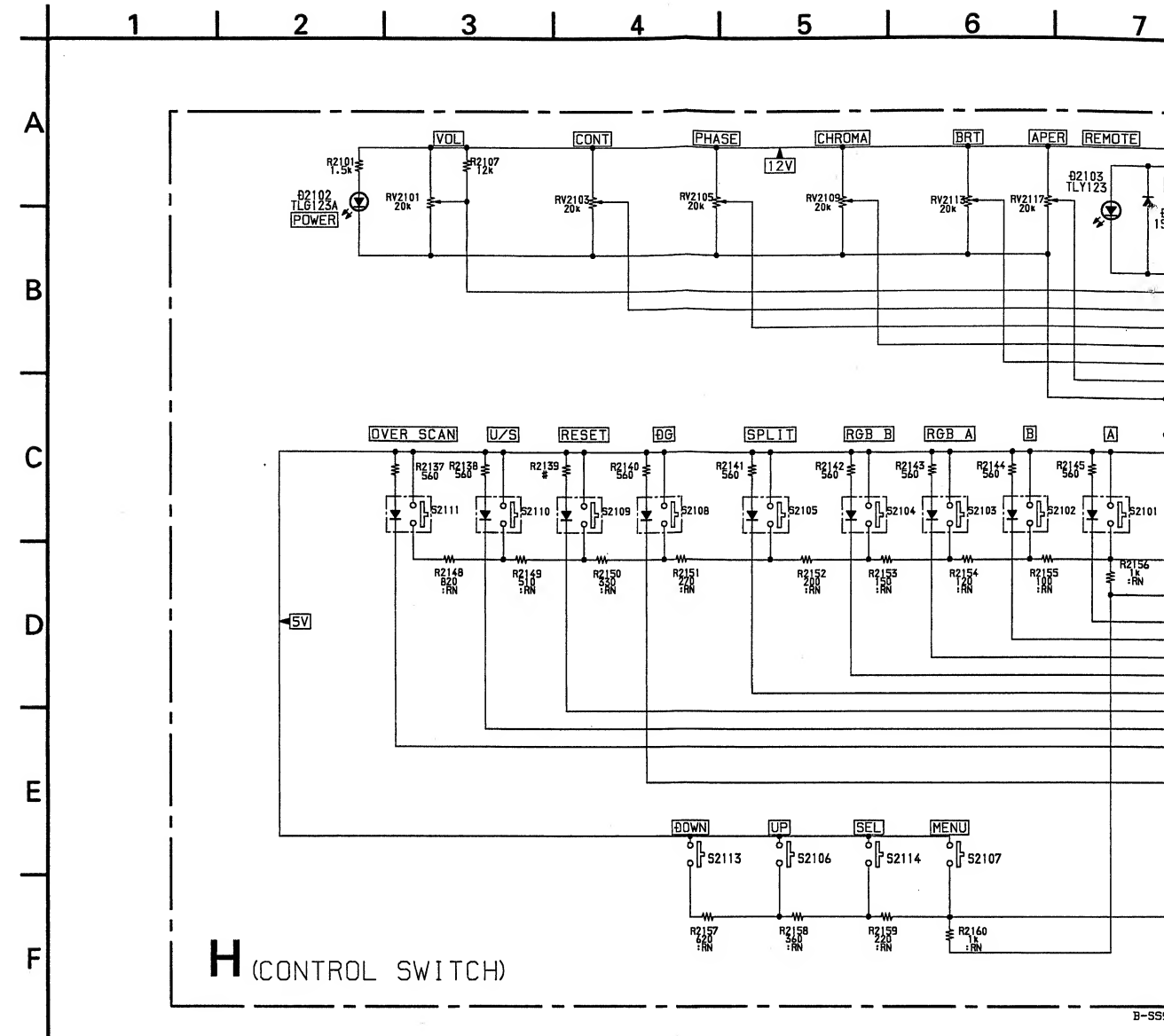
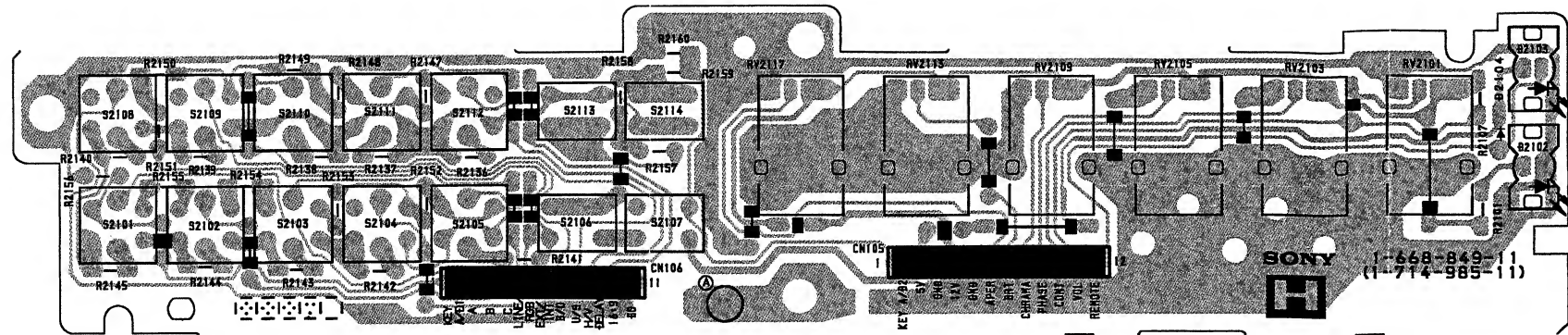

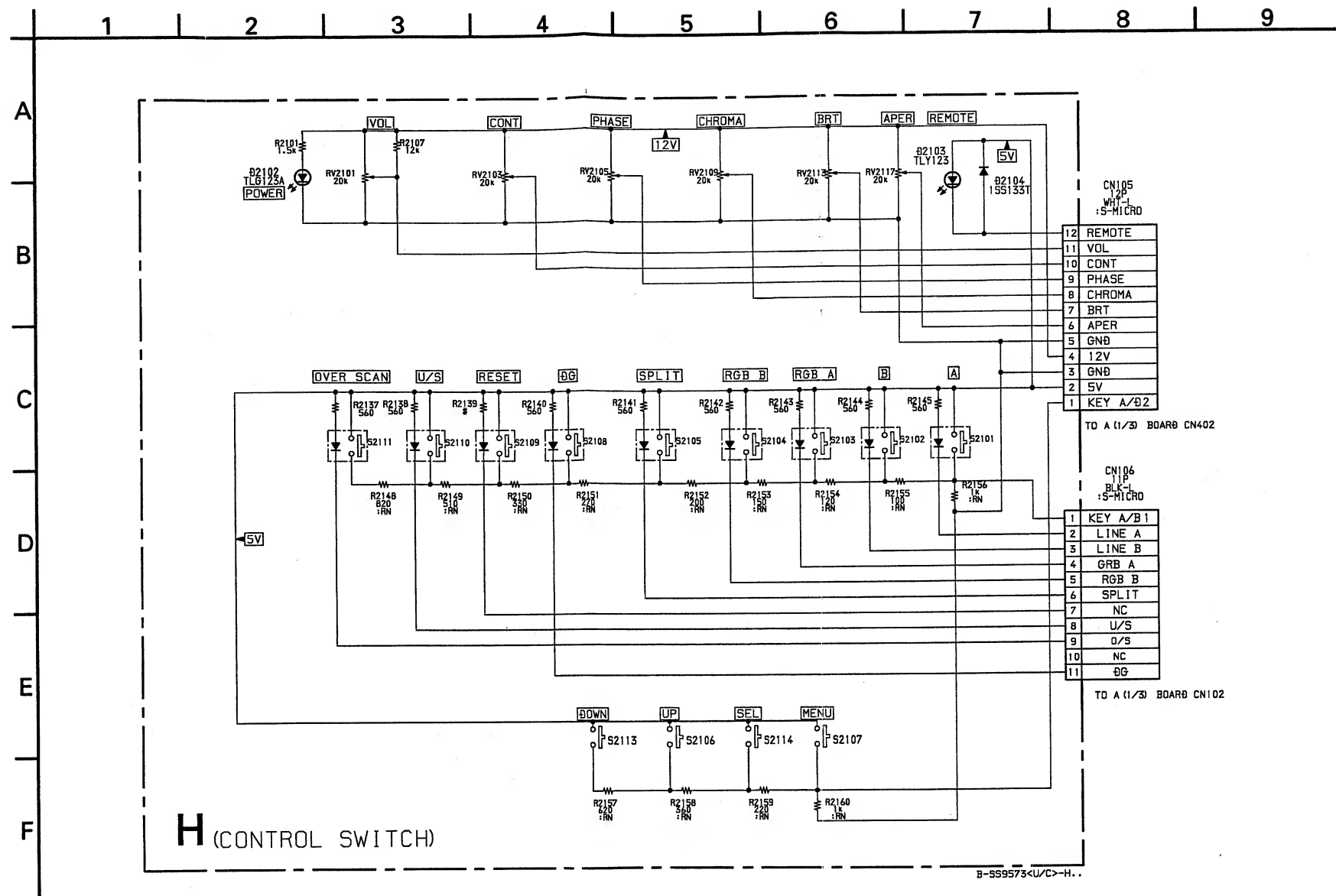
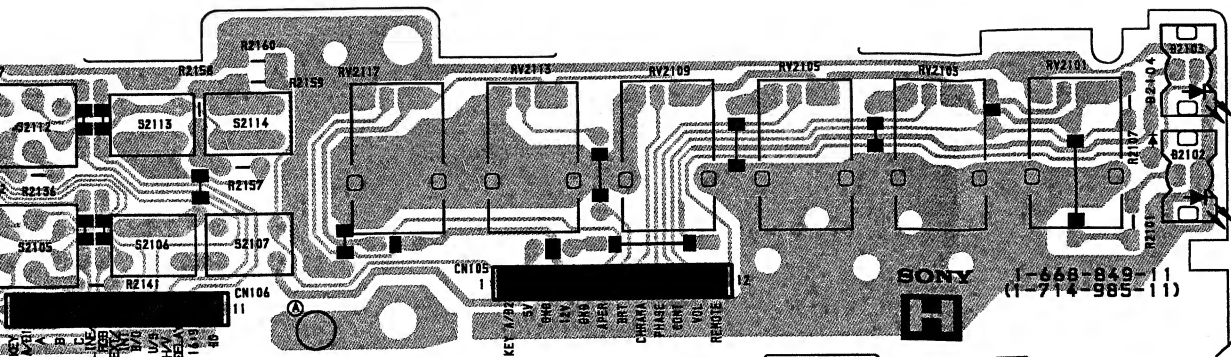

A

MICON, RGB-MATRIX, DAC,
ON SCREEN DISPLAY, ON/OFF-MUTE,
VOL OFF SW, RGB SW

CHROMA DEMOD, SYSTEM SW,
SYNC SELECT, B/B-Y SW, R/R-Y SW,
G/Y SW, AUDIO SELECT, HOLD AMP

H/V OUT, DEFLECTIN SYSTEM,
AUDIO OUT

- A BOARD - <A Side>

**A BOARD
(A SIDE)**

IC	TRANSISTOR	Q524 A-6	Q534 E-5	Q535 E-5
IC101	A-2	DIODE		
IC102	B-1			
IC103	C-1	D100	D-5	
IC104	B-2	D104	B-1	
IC105	B-3	D105	B-1	
IC106	C-3	D108	D-5	
IC107	C-2	D109	A-1	
IC109	B-3	D114	F-2	
IC110	C-3	D300	G-2	
IC111	B-2	D301	D-2	
IC112	B-1	D305	G-3	
IC200	A-5	D308	F-2	
IC302	G-3	D313	G-5	
IC303	F-1	D314	C-1	
IC304	F-1	D326	E-2	
IC305	F-2	D327	D-3	
IC306	F-3	D332	F-3	
IC307	F-1	D338	F-3	
IC309	F-3	D360	C-3	
IC310	D-3	D361	C-3	
IC311	D-3	D362	F-2	
IC312	F-3	D365	F-4	
IC313	F-2	D381	C-2	
IC314	G-4	D406	C-1	
IC315	D-2	D414	C-4	
IC316	E-1	D415	D-5	
IC317	D-1	D416	D-4	
IC318	D-2	D417	D-4	
IC319	F-2	D418	D-4	
IC320	F-5	D423	C-6	
IC321	F-5	D424	B-5	
IC322	F-5	D502	D-9	
IC323	F-5	D504	D-8	
IC324	F-4	D505	F-9	
IC325	F-4	D506	D-9	
IC326	D-2	D510	T-6	
IC327	C-3	D512	D-9	
IC350	D-2	D514	F-7	
IC402	D-4	D515	F-9	
IC404	D-4	D520	E-6	
IC405	C-5	D521	C-6	
IC407	C-5	D522	D-6	
IC408	C-6	D524	C-8	
IC409	C-5	D525	C-9	
IC410	B-4	D527	B-8	
IC411	B-5	D528	A-9	
IC412	B-4	D529	A-8	
IC413	B-4	D530	A-9	
IC500	G-8	D533	G-8	
IC502	G-6	D535	B-6	
IC503	F-6	D538	D-6	
IC504	C-7	D540	F-6	
IC505	E-6	D541	F-3	
IC506	E-6	D543	G-5	
IC507	D-7	VARIABLE RESISTOR		
IC508	C-7	RV501	B-8	
IC509	C-7			
IC510	F-3			
IC513	F-2			

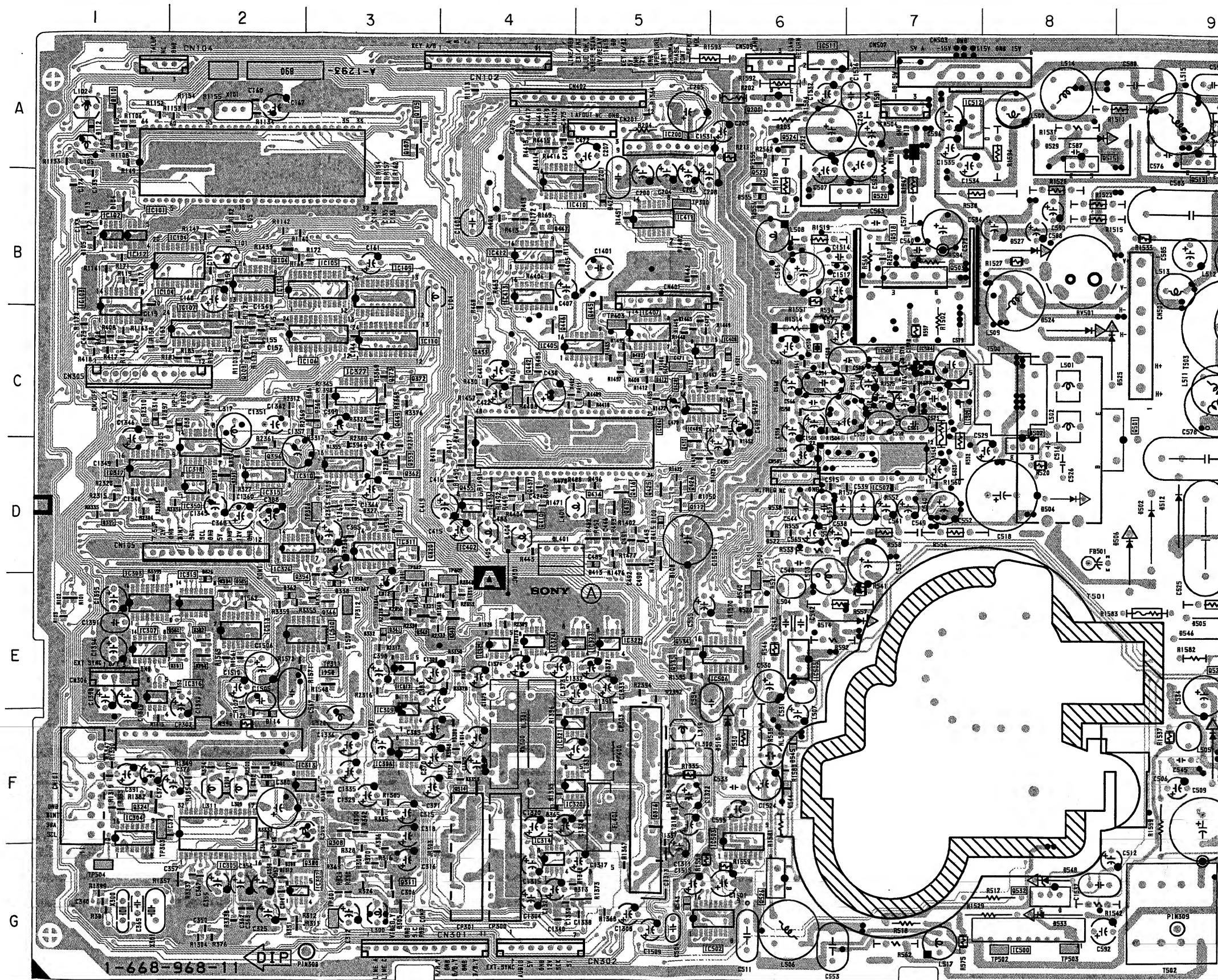

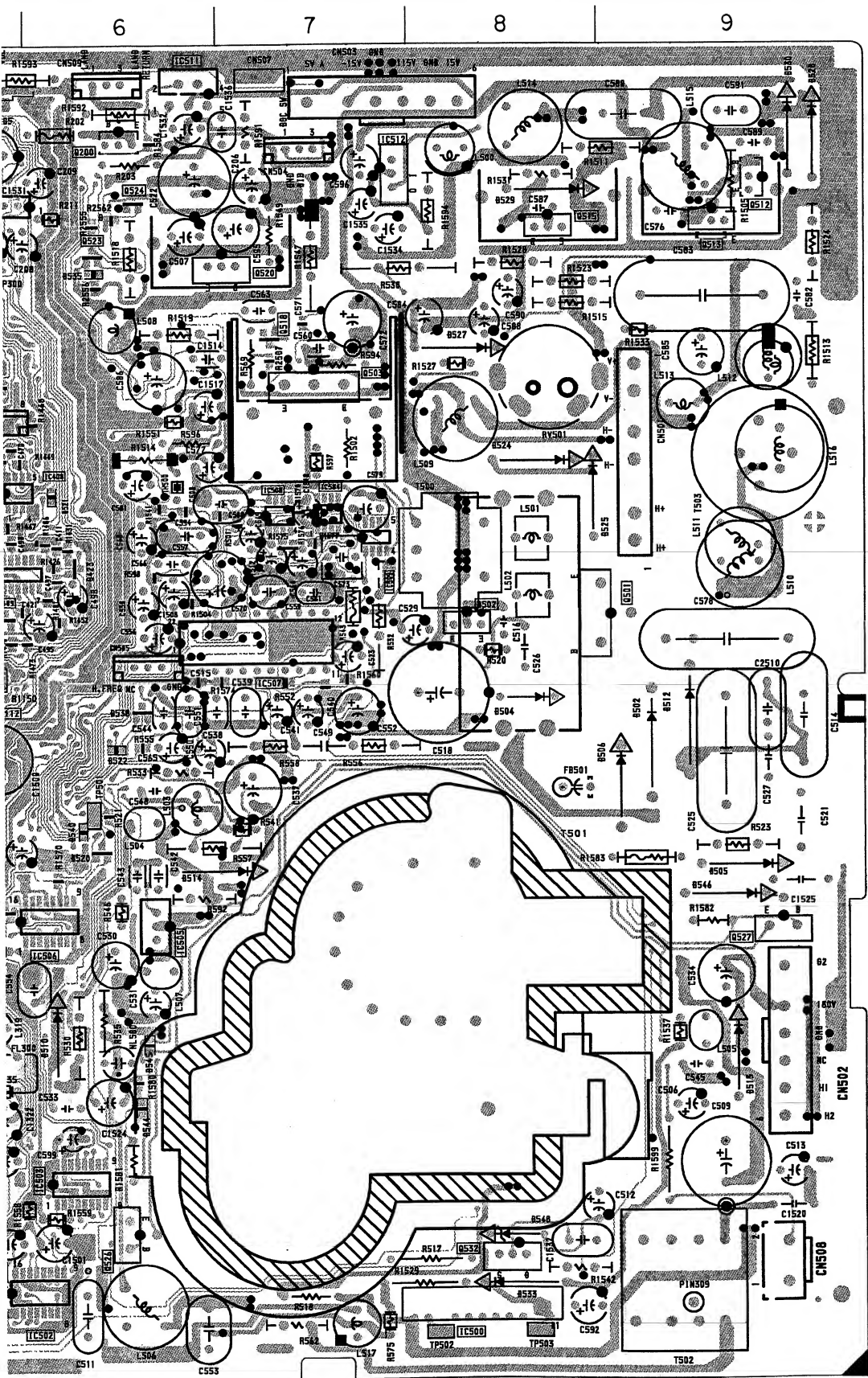

<B Side>

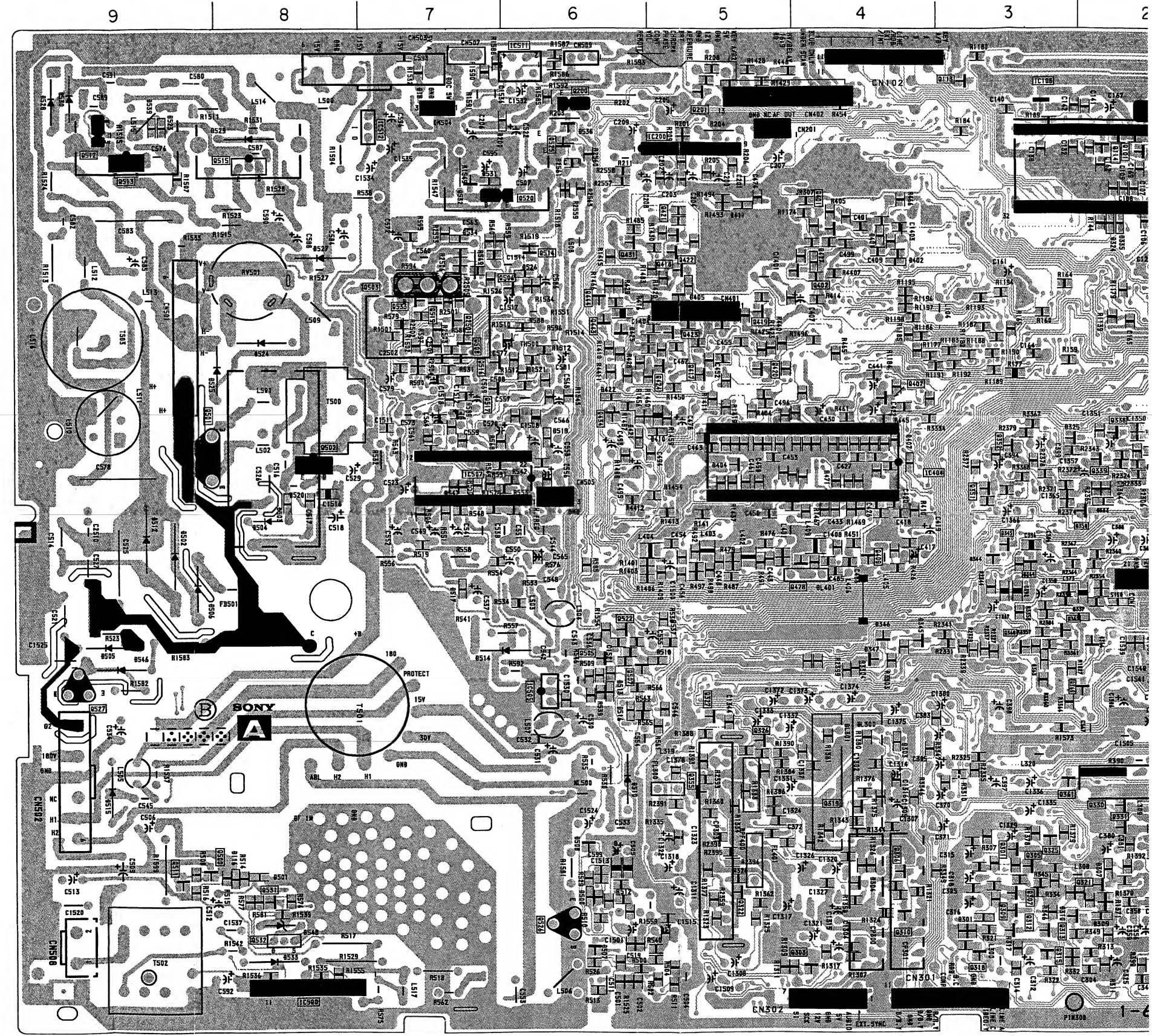

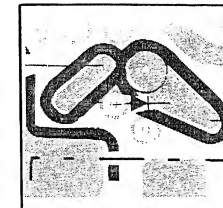

NOTE:
The circuit indicated as left contains high voltage of over 600 Vp-p. Care must be paid to prevent an electric shock in inspection or repairing.

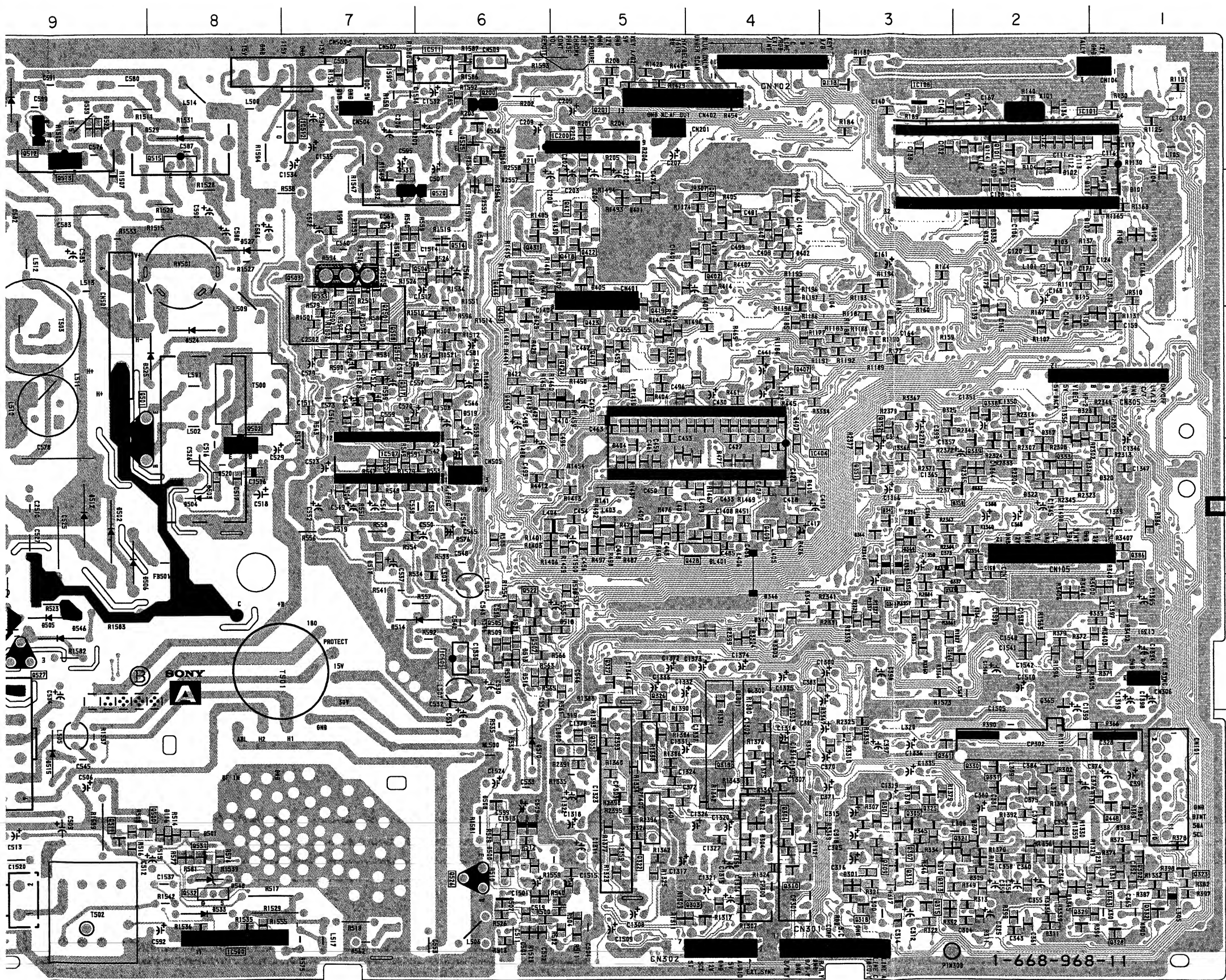

**A BOARD
(B SIDE)**

IC		Q407 C-4	D324 B-2
IC101 A-2	Q409 D-4	D325 C-3	
IC108 A-3	Q417 C-5	D333 D-2	
IC200 A-5	Q418 B-5	D335 B-2	
IC404 D-4	Q419 C-5	D337 E-2	
IC500 G-8	Q420 C-5	D339 E-1	
IC505 E-6	Q421 B-5	D344 D-3	
IC507 D-7	Q422 B-5	D345 E-4	
	Q423 C-5	D346 E-4	
	Q424 C-5	D347 E-4	
	Q428 D-4	D363 E-3	
	Q431 B-6	D364 E-2	
	Q434 C-6	D401 B-4	
	Q443 C-6	D404 D-5	
	Q444 B-6	D405 B-5	
	Q448 F-1	D407 D-4	
	Q500 F-9	D410 C-5	
	Q501 C-9	D411 B-5	
	Q502 D-8	D421 C-6	
	Q503 B-7	D422 C-6	
	Q505 E-6	D425 C-6	
	Q506 B-6	D427 B-4	
	Q507 E-6	D500 G-6	
	Q508 C-7	D501 F-8	
	Q511 F-9	D502 D-9	
	Q512 A-9	D503 D-8	
	Q513 A-9	D504 D-8	
	Q514 B-6	D505 E-9	
	Q515 A-8	D506 D-9	
	Q516 C-7	D507 G-6	
	Q517 C-7	D508 F-6	
	Q519 B-7	D510 F-6	
	Q520 B-7	D512 D-9	
	Q522 E-6	D513 E-6	
	Q525 A-6	D514 E-7	
	Q533 B-7	D515 F-9	
	Q2501 C-7	D516 E-6	
		D517 D-7	
		D518 E-5	
		D519 C-6	
		D523 A-9	
		D524 C-8	
		D525 C-9	
		D526 B-6	
		D527 B-8	
		D528 A-9	
		D529 A-8	
		D530 A-9	
		D531 B-7	
		D532 B-7	
		D533 G-8	
		D534 B-7	
		D536 A-6	
		D539 A-9	
		DIODE	
		D101 B-1	
		D102 B-2	
		D103 B-2	
		D107 B-1	
		D111 B-1	
		D115 B-2	
		D116 F-8	
		D200 A-6	
		D301 G-3	
		D303 F-4	
		D304 F-4	
		D307 F-2	
		D309 G-2	
		D310 G-3	
		D311 G-2	
		D315 D-2	
		D317 C-2	
		D320 D-2	
		D322 D-2	
		D323 C-2	
		VARIABLE RESISTOR	
		RV501 B-8	

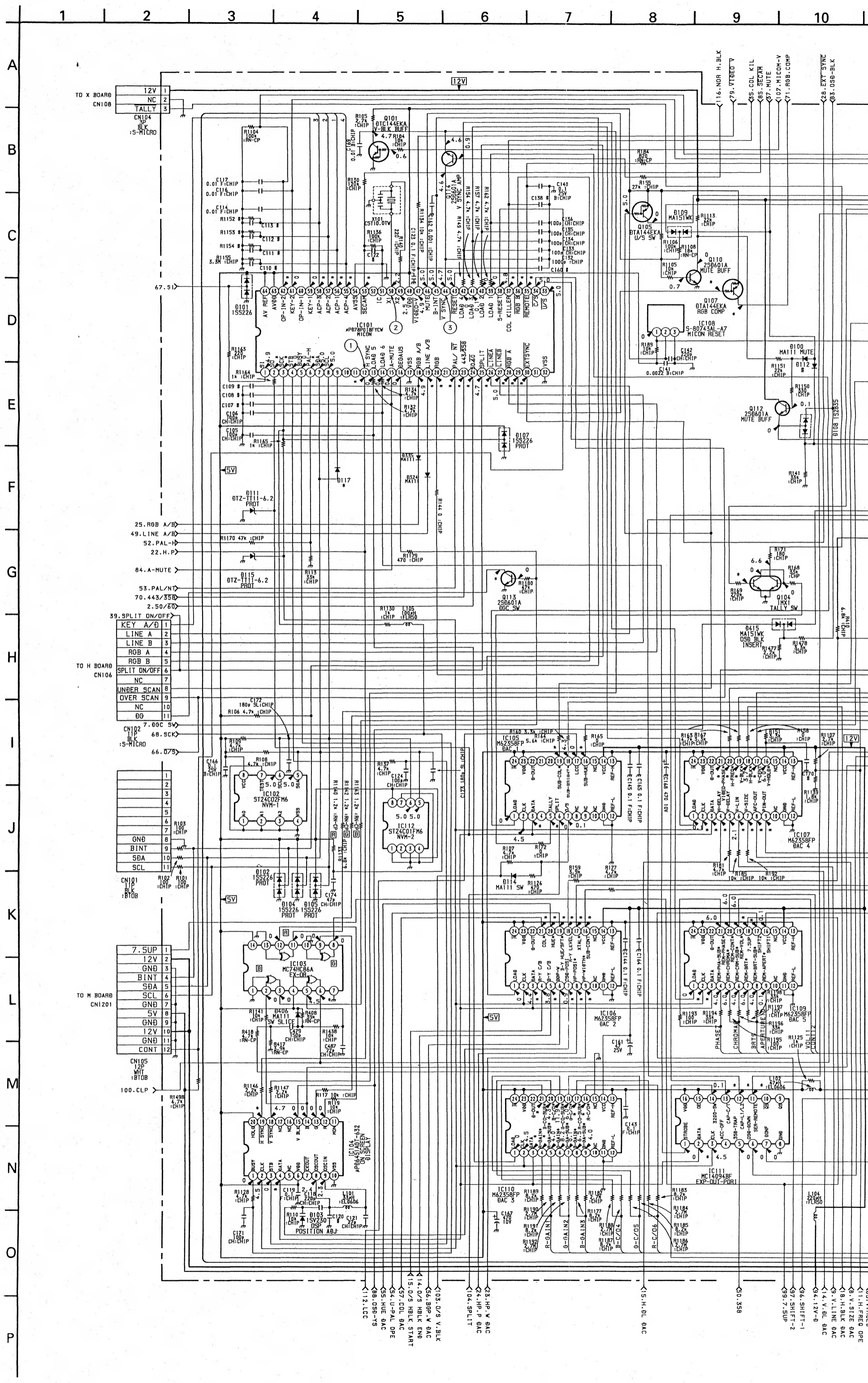

TO X BOARD
CN108

TO H BOARD
CN106

TO M BOARD
CN1201

- 12V
- NC
- TALLY

- KEY A/D
- LINE A
- LINE B
- RGB A
- RGB B
- SPLIT ON/OFF
- NC
- UNDER SCAN
- OVER SCAN
- NC
- OG

- 7. SUP
- 12V
- GND
- BINT
- SBA
- SCL
- GND
- 5V
- GND
- 12V
- GND
- CONT

100. CLP



A (1/3)
 (MICON, RGB-MATRIX,
 DAC, ON SCREEN DISPLAY,
 ON/OFF-MUTE, VOL OFF SW,
 RGB SW)

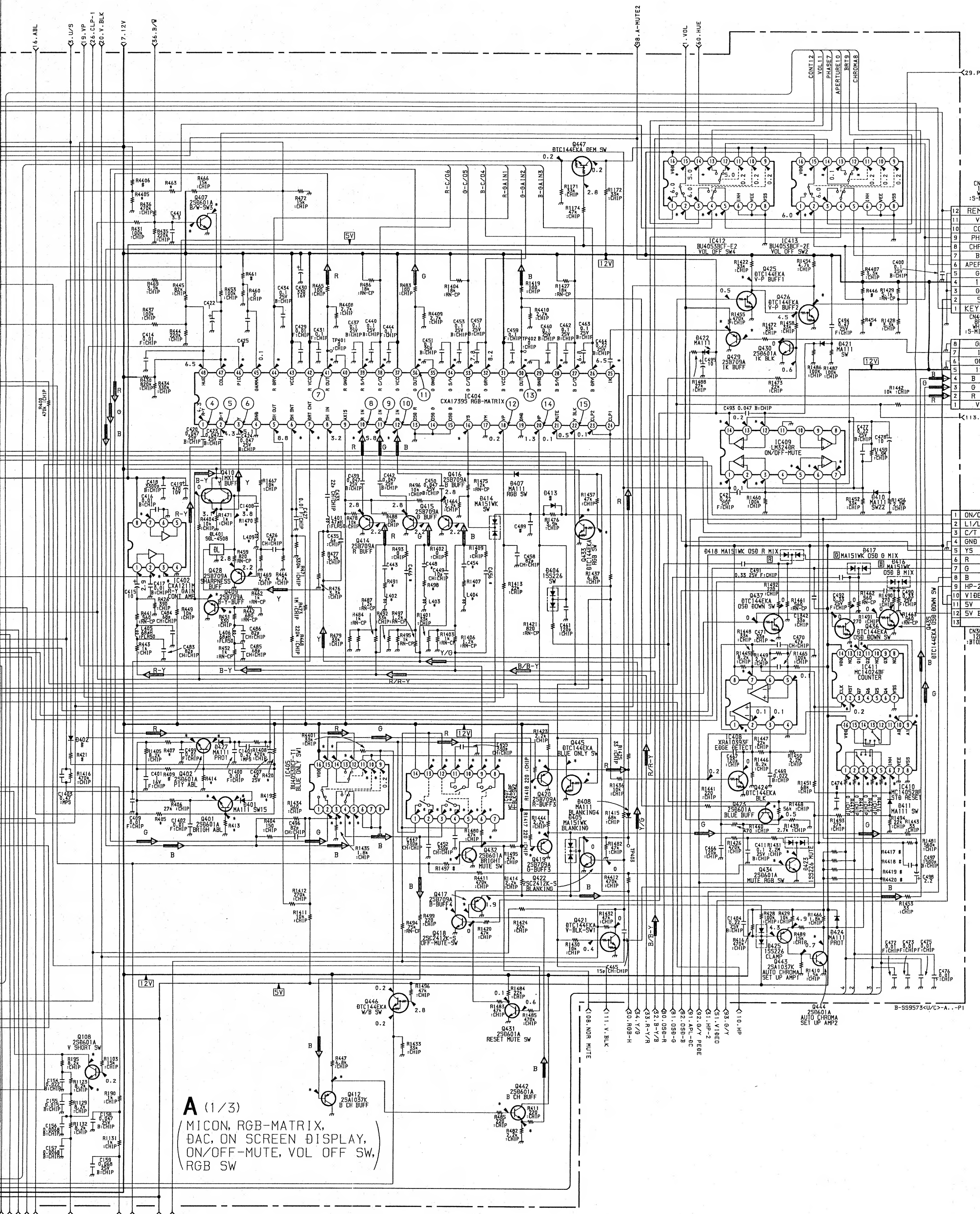

A (1/3)
 (MICON, RGB-MATRIX,
 DAC, ON SCREEN DISPLAY,
 ON/OFF-MUTE, VOL OFF SW,
 RGB SW

- 12 REM
- 11 VI
- 10 CO
- 9 PH
- 8 CHR
- 7 BI
- 6 APER
- 5 T
- 4 G
- 3 G
- 2 S
- 1 KEY
- 8 ON/O
- 7 LI/L
- 6 C/T
- 5 YS
- 4 G
- 3 G
- 2 HP-2
- 1 VIDE
- 12 SV B
- 13
- CN30
- BT0B

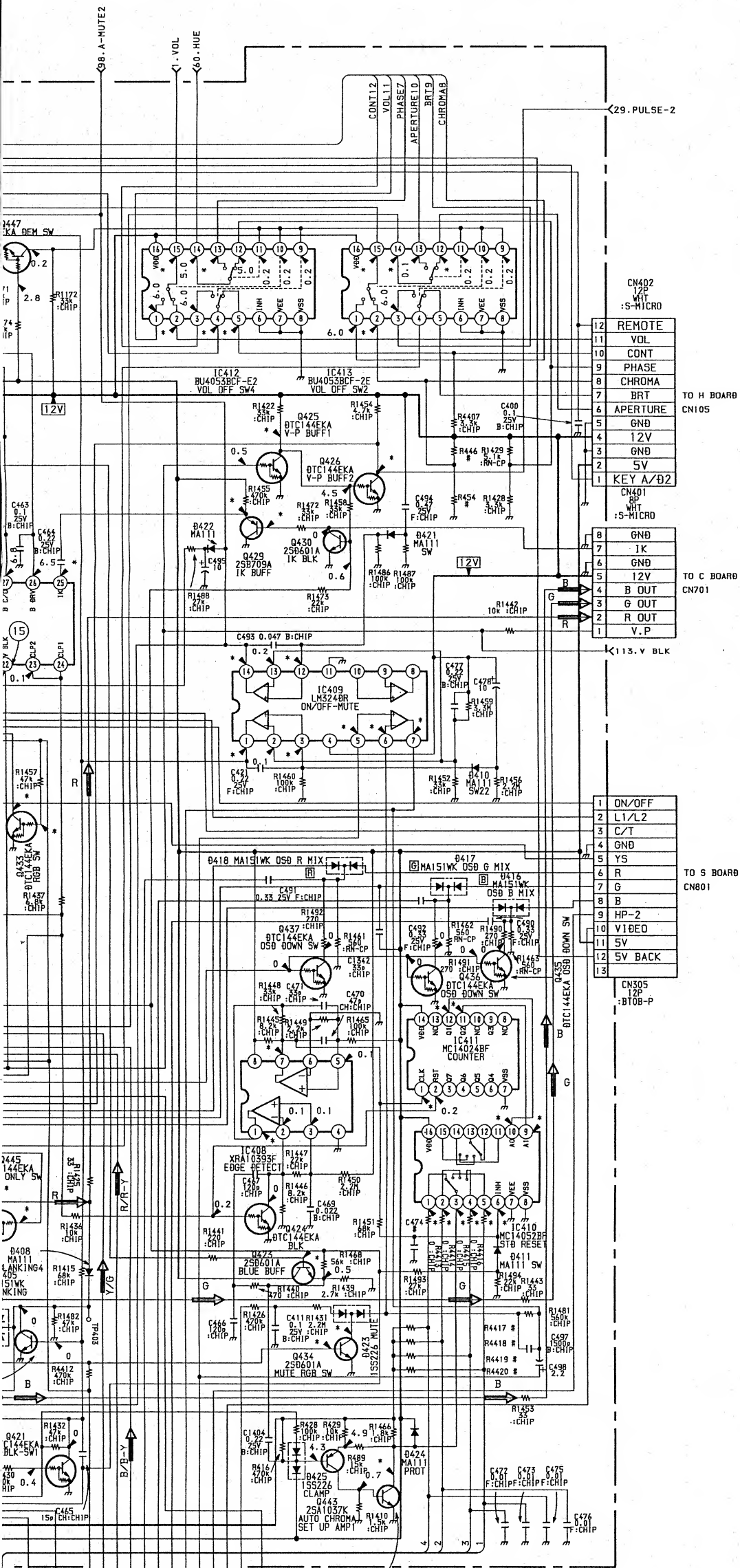

A (1/3) BOARD WAVEFORMS

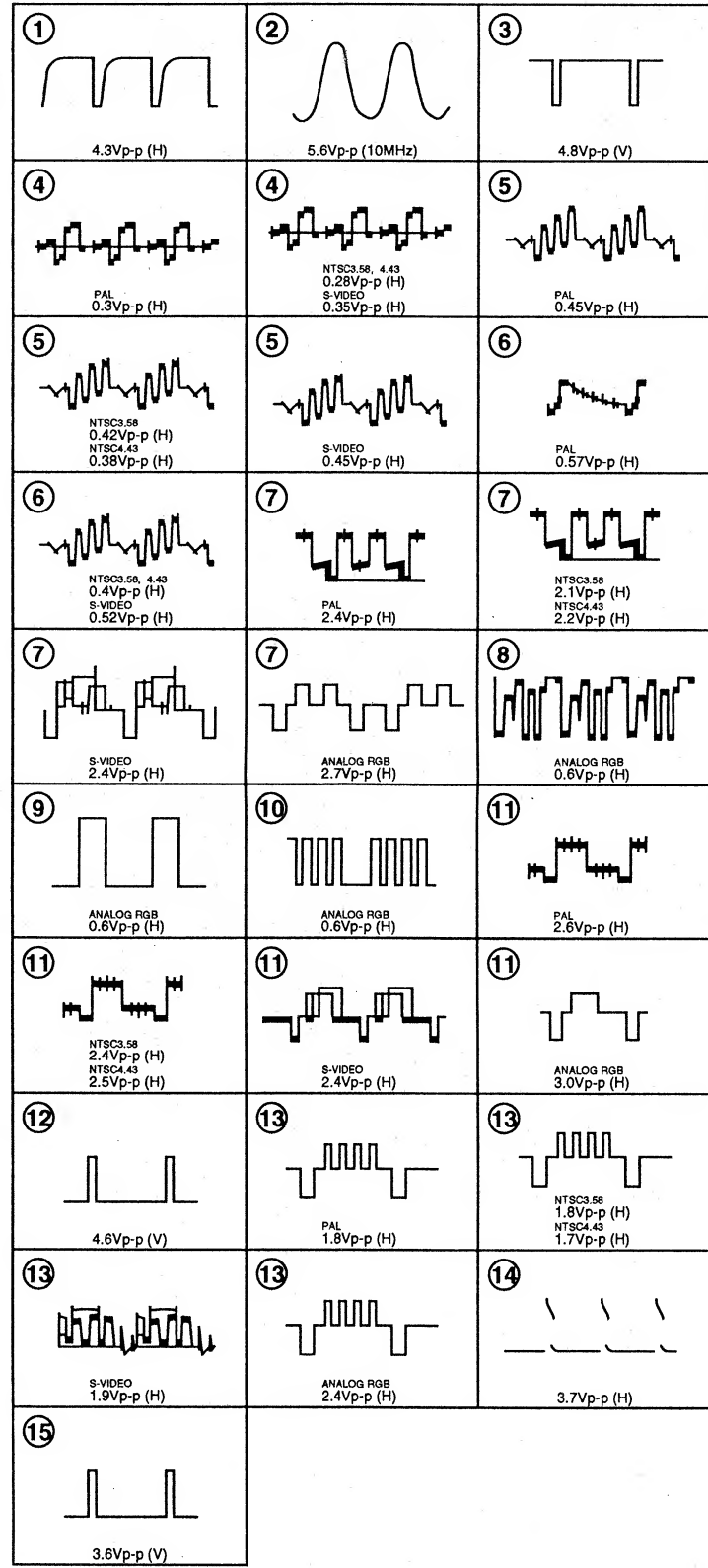

A (1/3) BOARD * MARK LIST

IC	PAL	NTSC
IC101 ②	2.3	3.58
③	4.5	4.5
④	4.1	0
⑤	3.4	3.5
⑥	0	0
⑦	0	0
⑧	4.9	0
⑨	5.0	0
⑩	5.0	0
⑪	0.1	0.1
⑫	5.0	5.0
⑬	5.0	5.0
⑭	4.2	4.6
⑮	4.0	4.6
⑯	0.3	0.1
⑰	4.2	4.3
⑱	4.0	3.6
⑲	0.5	1.0
⑳	3.0	2.6
㉑	3.6	2.9
㉒	4.0	4.0
IC103 ④	0.2	0.2
IC104 ④	2.3	2.2
⑤	3.5	3.5
IC105 ③	2.3	2.2
④	0	0.1
⑤	2.6	2.7
⑥	5.4	5.4
IC106 ③	2.3	2.2
④	5.4	5.4
⑤	2.4	2.4
⑥	7.8	7.8
⑦	5.1	5.1
⑧	0.1	10.5
⑨	3.1	2.6
⑩	2.4	2.1
⑪	6.3	11.9
⑫	3.6	4.8
⑬	0.8	0.4
IC107 ②	4.6	4.5
③	2.3	2.2
④	2.8	2.8
⑤	1.5	1.4
⑥	2.9	2.9
⑦	2.6	2.6
⑧	2.9	2.9
⑨	2.6	2.8
⑩	3.2	5.4
⑪	4.5	5.0
⑫	6.3	6.1
IC109 ②	4.6	4.5
③	2.3	2.2
④	11.9	11.9
⑤	11.9	0.1
IC110 ②	2.3	2.2
③	7.2	7.2
④	5.8	5.8
⑤	11.9	11.9
⑥	0	7.9
⑦	3.7	3.5
IC111 ②	2.3	2.2
③	0.3	0.3
④	0.2	0.1
⑤	0	5.0
⑥	5.0	5.0
IC402 ②	3.1	2.9
③	0	2.3
④	2.9	2.9
IC404 ⑥	3.0	3.0
⑦	4.9	4.9
⑧	5.6	5.6
⑨	5.6	5.6
⑩	0	0
⑪	3.8	4.0
⑫	7.1	8.0
⑬	1.4	1.2
⑭	7.0	8.1
⑮	1.4	1.2
⑯	7.8	7.7
⑰	6.9	7.8
⑱	1.2	1.0
⑲	7.2	7.2
㉑	7.2	7.2
㉒	6.6	6.6
㉓	6.6	6.6
IC405 ①	1.6	1.1
②	1.4	0.9
③	1.2	0.9
④	1.4	1.0
⑤	1.3	1.0
⑥	0.5	0.6
⑦	0.5	0.6
⑧	1.2	0.8

A (1/3) BOARD * MARK LIST

	20INCH MODEL	14INCH MODEL
C443	39p :CHIP	47p CH:CHIP
C446	12p CH:CHIP	6p :CHIP
C448	39p :CHIP	47p CH:CHIP
C454	39p :CHIP	47p CH:CHIP
C456	12p CH:CHIP	6p :CHIP
C1408	39p :CHIP	68p CH:CHIP
L402	82μH :CHIP	100μH :CHIP
L403	82μH :CHIP	100μH :CHIP
L404	82μH :CHIP	100μH :CHIP
L409	82μH :CHIP	68μH :CHIP
R405	1M :CHIP	#
R407	33k :CHIP	15k :CHIP
R413	1M :CHIP	5.1k :RN-CP
R414	0 :CHIP	8.2k :RN-CP
R419	#	4.7k :CHIP
R420	#	33k RN:CHIP
R463	3.9k :CHIP	4.7k :CHIP
R491	3.9k :CHIP	3.3k :CHIP
R498	3.9k :CHIP	3.3k :CHIP
R1407	3.9k :CHIP	3.3k :CHIP
R1470	3.3k :CHIP	2.2k :CHIP
R4405	6.8k :CHIP	5.6k :CHIP

A (1/3) BOARD * MARK VOLTAGE

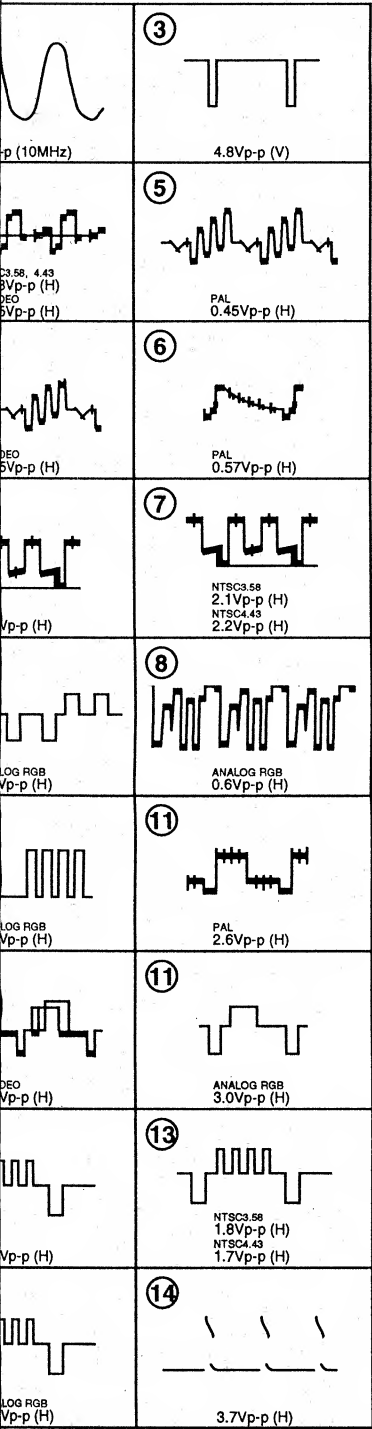

14INCH MODEL

CH:CHIP
CHIP
CH:CHIP
CH:CHIP
CHIP
CH:CHIP
μH :CHIP
μH :CHIP
μH :CHIP
H :CHIP
CHIP
CHIP
RN:CHIP
RN:CHIP
CHIP
RN:CHIP
CHIP
CHIP
CHIP
CHIP

	PAL	NTSC 3.58	NTSC 4.43	S-VIDEO	ANALOG RGB
IC101 ②	2.3	2.2	2.2	2.0	2.3
③	4.5	4.5	4.4	4.4	4.5
⑥	4.1	0	0.1	0	0
⑩	3.4	3.5	3.5	3.1	3.5
⑫	0	0	0	4.8	0
⑮	0	0	0	0	4.9
⑰	4.9	0	0	0	0
⑲	5.0	0	5.0	0	0
⑳	5.0	0	0	0	0
㉑	0.1	0.1	0.1	4.9	0.1
㉒	5.0	5.0	5.0	0	5.0
㉓	5.0	5.0	5.0	4.9	0.1
㉔	5.0	5.0	5.0	5.0	0.1
㉕	4.2	4.6	5.0	3.9	3.9
㉖	4.0	4.6	5.0	3.6	3.7
㉗	0.3	0.1	0.7	0.1	0.1
㉘	4.2	4.3	4.2	4.2	4.3
㉙	4.0	3.6	3.7	3.9	4.0
㉚	0.5	1.0	0.8	3.1	1.9
㉛	3.0	2.6	2.3	3.8	2.2
㉜	3.6	2.9	3.2	3.9	4.0
㉝	4.0	4.0	4.0	2.9	4.0
IC103 ⑥	0.2	0.2	0.2	0	0
IC104 ④	2.3	2.2	2.2	2.0	2.3
⑩	3.5	3.5	3.5	3.1	3.5
IC105 ③	2.3	2.2	2.2	0	2.3
⑤	0	0.1	0	11.8	0
⑩	2.6	2.7	2.6	2.8	2.6
⑫	5.4	5.4	5.4	6.6	8.1
IC106 ①	2.3	2.2	2.2	2.1	2.3
⑤	5.4	5.4	5.4	4.1	5.4
⑦	2.4	2.4	2.4	0.6	2.4
⑩	7.8	7.8	7.7	5.5	7.8
⑫	5.1	5.1	5.1	4.0	5.1
⑮	0.1	10.5	10.5	10.9	10.5
⑰	3.1	2.6	3.1	2.7	2.5
⑲	2.4	2.1	2.2	2.1	3.2
㉑	6.3	11.9	9.0	10.7	3.7
㉒	3.6	4.8	3.6	4.3	9.5
㉔	0.8	0.4	0.3	2.4	3.1
IC107 ②	4.6	4.5	4.5	4.4	4.5
④	2.3	2.2	0	2.1	0
⑥	2.8	2.8	2.8	3.3	2.8
⑧	1.5	1.4	1.4	2.3	1.4
⑩	2.9	2.9	2.9	2.1	2.9
⑫	2.6	2.6	2.6	2.9	2.6
⑮	2.9	2.9	2.9	2.6	2.9
⑰	2.6	2.8	2.8	2.8	2.8
⑲	3.2	5.4	5.4	5.3	5.4
㉑	4.5	5.0	5.0	3.7	5.0
㉒	6.3	6.1	6.1	6.0	6.1
IC109 ②	4.6	4.5	4.5	4.4	4.4
④	2.3	2.2	2.2	2.1	2.3
⑥	11.9	11.9	11.9	11.9	0.1
⑩	11.9	0.1	0	0.1	11.8
IC110 ⑤	2.3	2.2	2.2	2.0	2.2
⑦	7.2	7.2	7.2	8.3	7.2
⑩	5.8	5.8	5.8	6.2	5.8
⑫	11.9	11.9	11.9	7.8	11.9
⑮	0	7.9	7.9	7.8	7.9
⑰	3.7	3.5	3.5	3.5	3.6
IC111 ②	2.3	2.2	2.2	2.0	2.2
④	0.3	0.3	0.3	0	0.3
⑩	0.2	0.1	0.1	0.1	0.1
⑫	0	5.0	5.0	0	5.0
⑮	5.0	5.0	5.0	0	5.0
IC402 ②	3.1	2.9	3.0	3.0	3.6
④	0	2.3	0	2.2	2.2
⑥	2.9	2.9	0	2.9	2.9
IC404 ⑥	3.0	3.0	3.0	4.5	0
⑧	4.9	4.9	4.9	4.7	6.1
⑩	5.6	5.6	5.6	5.6	5.8
⑫	5.6	5.6	5.6	5.6	5.8
⑮	0	0	0	0	4.4
⑰	3.8	4.0	4.2	4.0	3.6
⑲	7.1	8.0	8.0	7.7	7.9
㉑	1.4	1.2	1.1	1.2	1.4
㉒	7.0	8.1	7.8	7.8	7.8
㉔	1.4	1.2	1.1	1.2	1.5
㉕	7.8	7.7	7.8	8.0	7.7
㉖	6.9	7.8	7.7	7.6	7.6
㉘	1.2	1.0	1.0	1.2	1.3
㉙	7.2	7.2	7.2	8.3	7.2
㉚	7.2	7.2	7.2	6.9	7.0
㉜	6.6	6.6	6.6	5.5	0
IC405 ①	1.6	1.1	1.3	1.4	1.6
②	1.4	0.9	0	1.2	1.5
③	1.2	0.9	0	1.1	1.2
④	1.4	1.0	0	1.2	1.4
⑤	1.3	1.0	0	1.2	1.4
⑥	0.5	0.6	1.0	0.3	0.2
⑦	0.5	0.6	1.3	0.3	0.2
⑧	1.2	0.8	1.1	1.2	1.3

	PAL	NTSC 3.58	NTSC 4.43	S-VIDEO	ANALOG RGB
IC405 ⑩	1.4	0.9	1.3	1.3	1.4
⑫	1.2	0.8	1.2	1.2	1.3
⑮	1.4	1.0	1.3	1.2	1.5
IC407 ①	1.2	0.9	1.2	1.2	1.3
②	0.4	0.5	0.3	0.4	0.5
④	1.4	1.0	1.3	1.2	1.4
⑥	0.6	0.7	0.5	0.5	0.7
⑧	2.0	2.0	2.0	2.0	2.0
⑩	11.7	11.6	11.3	11.7	11.2
⑫	5.5	5.5	5.5	5.4	8.5
⑮	5.5	5.5	5.5	5.4	8.4
⑰	1.4	1.0	1.3	1.2	1.5
⑲	0.6	0.7	0.6	0.5	0.6
㉑	2.0	2.0	2.0	2.0	2.0
㉒	2.0	2.0	2.0	2.0	2.0
IC408 ①	3.1	2.9	3.1	3.7	3.4
③	4.1	3.9	4.1	4.2	4.1
IC409 ①	0	9.0	9.4	0	7.5
③	0	0.4	0.3	0.3	1.6
⑤	5.9	6.3	0	5.9	5.9
⑦	5.9	6.3	6.0	5.9	5.9
⑨	5.9	6.3	6.0	5.9	5.9
⑫	0.1	0.5	1.2	0.1	0
⑮	0	6.6	6.9	0	10.7
IC410 ①	3.8	4.0	4.0	0	3.9
②	3.0	2.4	3.1	0	4.0
④	1.3	1.4	1.6	2.3	1.5
⑥	3.5	3.0	3.8	3.9	3.9
⑧	0.6	1.1	1.1	3.1	1.7
⑩	4.0	4.0	3.9	0	0
⑫	0	1.9	1.8	2.5	1.4
⑮	2.0	2.3	2.0	1.8	3.0
IC411 ①	4.1	3.9	3.8	4.2	4.1
③	1.8	1.9	1.8	2.5	1.3
⑤	2.0	2.3	2.1	1.8	3.0
IC412 ②	0.4	0.4	0.4	5.9	0.6
④	8.9	8.9	8.9	8.9	8.3
⑥	9.0	9.0	8.9	8.9	8.3
⑧	6.0	6.0	6.0	6.0	0
⑩	0.4	0.4	0.4	5.9	0.5
IC413 ②	7.9	8.0	8.0	0	6.9
④	0	5.5	5.5	5.4	0
⑥	5.5	5.5	5.5	5.4	8.6
⑧	3.1	3.1	3.1	0	5.1
⑩	3.1	3.1	3.1	6.0	5.1
⑫	7.9	8.0	7.9	6.3	6.9
Q102 B	10.9	10.9	10.9	10.7	10.9
C	8.1	8.1	8.1	0	8.1
E	11.5	11.5	11.5	11.3	11.5
Q104.1B	-0.2	-0.2	0	0	-0.2
Q107 B	5.0	5.0	5.0	5.0	0.1
C	0	0	0	0	5.0
Q108 C	2.6	2.6	2.6	2.9	2.6
E	2.6	2.6	2.6	2.9	2.6
Q113 C	4.1	4.2	4.2	3.8	4.0
Q401 B	1.1	1.5	1.6	1.2	1.0
C	7.5	6.0	5.2	8.4	10.0
E	1.4	3.2	3.4	3.1	1.0
Q402 B	0.5	0.5	0.5	2.4	0.5
C	9.5	8.1	7.4	10.4	6.9
E	1.4	3.2	3.3	3.2	1.0
Q407 B	0	0	0	0	0.6
C	6.6	6.6	6.6	5.4	0
Q409 B	1.9	1.6	1.6	1.7	1.6
E	2.0	2.2	2.2	2.3	2.2
Q412 B	1.3	1.0	1.3	1.1	1.4
E	2.0	1.7	1.9	1.8	2.0
Q417 B	1.4	1.2	1.2	1.2	1.4
Q418 C	2.1	1.7	1.7	1.7	2.0
Q419 B	1.4	1.2	1.1	1.2	1.5
E	2.0	1.7	1.7	1.8	2.0
Q420 B	1.2	1.0	1.0	1.2	1.3
E	1.8	1.6	1.6	1.8	1.9
Q422 C	2.1	1.7	1.7	1.8	2.0
Q423 B	0.5	0.4	0.4	0.4	0.2
Q425 C	4.5	4.5	4.5	4.7	4.5
Q426 C	0.8	0.7	0.7	0.7	0
Q429 B	0.1	0.4	0.4	0.1	0.1
E	0	-1.2	-1.2	0.4	0.4
Q432 B	-0.3	-3.4	-2.7	-0.1	-3.9
C	11.9	11.8	11.8	12.0	11.6
Q433 B	0	0	0	0	2.7
C	3.0	3.0	3.0	4.5	0
Q434 B	-0.1	0	0	-0.1	0.4
C	3.6	4.5	4.8	2.9	0
Q441 G	-1.1	1.7	-4.8	0	-0.7
D	2.0	-8.1	1.9	1.8	2.0
S	2.0	1.6	1.9	1.8	2.0
Q442 B	1.3	1.1	1.1	1.1	2.1
E	0.9	0.7	0.7	0.7	1.5
Q444 C	1.2	1.2	1.4	2.2	1.3
Q445 C	0.4	1.4	1.3	0.3	0.4

MARK VOLTAGE

NTSC 4.43	S-VIDEO	ANALOG RGB
2.2	2.0	2.3
4.4	4.4	4.5
0.1	0	0
3.5	3.1	3.5
0	4.8	0
0	0	4.9
0	0	0
5.0	0	0
0	0	0
0.1	4.9	0.1
5.0	0	5.0
5.0	4.9	0.1
5.0	5.0	0.1
5.0	3.9	3.9
5.0	3.6	3.7
0.7	0.1	0.1
4.2	4.2	4.3
3.7	3.9	4.0
0.8	3.1	1.9
2.3	3.8	2.2
3.2	3.9	4.0
4.0	2.9	4.0
0.2	0	0
2.2	2.0	2.3
3.5	3.1	3.5
2.2	0	2.3
0	11.8	0
2.6	2.8	2.6
5.4	6.6	8.1
2.2	2.1	2.3
5.4	4.1	5.4
2.4	0.6	2.4
7.7	5.5	7.8
5.1	4.0	5.1
10.5	10.9	10.5
3.1	2.7	2.5
2.2	2.1	3.2
9.0	10.7	3.7
3.6	4.3	9.5
0.3	2.4	3.1
4.5	4.4	4.5
0	2.1	0
2.8	3.3	2.8
1.4	2.3	1.4
2.9	2.1	2.9
2.6	2.9	2.6
2.9	2.6	2.9
2.8	2.8	2.8
5.4	5.3	5.4
5.0	3.7	5.0
6.1	6.0	6.1
4.5	4.4	4.4
2.2	2.1	2.3
11.9	11.9	0.1
0	0.1	11.8
2.2	2.0	2.2
7.2	8.3	7.2
5.8	6.2	5.8
11.9	7.8	11.9
7.9	7.8	7.9
3.5	3.5	3.6
2.2	2.0	2.2
0.3	0	0.3
0.1	0.1	0.1
5.0	0	5.0
5.0	0	5.0
3.0	3.0	3.6
0	2.2	2.2
0	2.9	2.9
3.0	4.5	0
4.9	4.7	6.1
5.6	5.6	5.8
5.6	5.6	5.8
0	0	4.4
4.2	4.0	3.6
8.0	7.7	7.9
1.1	1.2	1.4
7.8	7.8	7.8
1.1	1.2	1.5
7.8	8.0	7.7
7.7	7.6	7.6
1.0	1.2	1.3
7.2	8.3	7.2
7.2	6.9	7.0
6.6	5.5	0
1.3	1.4	1.6
0	1.2	1.5
0	1.1	1.2
0	1.2	1.4
0	1.2	1.4
1.0	0.3	0.2
1.3	0.3	0.2
1.1	1.2	1.3

	PAL	NTSC 3.58	NTSC 4.43	S-VIDEO	ANALOG RGB
IC405 ⑩	1.4	0.9	1.3	1.3	1.4
⑩	1.2	0.8	1.2	1.2	1.3
⑩	1.4	1.0	1.3	1.2	1.5
IC407 ①	1.2	0.9	1.2	1.2	1.3
②	0.4	0.5	0.3	0.4	0.5
③	1.4	1.0	1.3	1.2	1.4
④	0.6	0.7	0.5	0.5	0.7
⑤	2.0	2.0	2.0	2.0	2.0
⑥	11.7	11.6	11.3	11.7	11.2
⑦	5.5	5.5	5.5	5.4	8.5
⑧	5.5	5.5	5.5	5.4	8.4
⑨	1.4	1.0	1.3	1.2	1.5
⑩	0.6	0.7	0.6	0.5	0.6
⑪	2.0	2.0	2.0	2.0	2.0
⑫	2.0	2.0	2.0	2.0	2.0
IC408 ①	3.1	2.9	3.1	3.7	3.4
②	4.1	3.9	4.1	4.2	4.1
IC409 ①	0	9.0	9.4	0	7.5
②	0	0.4	0.3	0.3	1.6
③	5.9	6.3	0	5.9	5.9
④	5.9	6.3	6.0	5.9	5.9
⑤	5.9	6.3	6.0	5.9	5.9
⑥	0.1	0.5	1.2	0.1	0
⑦	0	6.6	6.9	0	10.7
IC410 ①	3.8	4.0	4.0	0	3.9
②	3.0	2.4	3.1	0	4.0
③	1.3	1.4	1.6	2.3	1.5
④	3.5	3.0	3.8	3.9	3.9
⑤	0.6	1.1	1.1	3.1	1.7
⑥	4.0	4.0	3.9	0	0
⑦	0	1.9	1.8	2.5	1.4
⑧	2.0	2.3	2.0	1.8	3.0
IC411 ①	4.1	3.9	3.8	4.2	4.1
②	1.8	1.9	1.8	2.5	1.3
③	2.0	2.3	2.1	1.8	3.0
IC412 ②	0.4	0.4	0.4	5.9	0.6
③	8.9	8.9	8.9	8.9	8.3
④	9.0	9.0	8.9	8.9	8.3
⑤	6.0	6.0	6.0	6.0	0
⑥	0.4	0.4	0.4	5.9	0.5
IC413 ②	7.9	8.0	8.0	0	6.9
③	0	5.5	5.5	5.4	0
④	5.5	5.5	5.5	5.4	8.6
⑤	3.1	3.1	3.1	0	5.1
⑥	3.1	3.1	3.1	6.0	5.1
⑦	7.9	8.0	7.9	6.3	6.9
Q102 B	10.9	10.9	10.9	10.7	10.9
C	8.1	8.1	8.1	0	8.1
E	11.5	11.5	11.5	11.3	11.5
Q104.1B	-0.2	-0.2	0	0	-0.2
Q107 B	5.0	5.0	5.0	5.0	0.1
C	0	0	0	0	5.0
Q108 C	2.6	2.6	2.6	2.9	2.6
E	2.6	2.6	2.6	2.9	2.6
Q113 C	4.1	4.2	4.2	3.8	4.0
Q401 B	1.1	1.5	1.6	1.2	1.0
C	7.5	6.0	5.2	8.4	10.0
E	1.4	3.2	3.4	3.1	1.0
Q402 B	0.5	0.5	0.5	2.4	0.5
C	9.5	8.1	7.4	10.4	6.9
E	1.4	3.2	3.3	3.2	1.0
Q407 B	0	0	0	0	0.6
C	6.6	6.6	6.6	5.4	0
Q409 B	1.9	1.6	1.6	1.7	1.6
E	2.0	2.2	2.2	2.3	2.2
Q412 B	1.3	1.0	1.3	1.1	1.4
E	2.0	1.7	1.9	1.8	2.0
Q417 B	1.4	1.2	1.2	1.2	1.4
Q418 C	2.1	1.7	1.7	1.7	2.0
Q419 B	1.4	1.2	1.1	1.2	1.5
E	2.0	1.7	1.7	1.8	2.0
Q420 B	1.2	1.0	1.0	1.2	1.3
E	1.8	1.6	1.6	1.8	1.9
Q422 C	2.1	1.7	1.7	1.8	2.0
Q423 B	0.5	0.4	0.4	0.4	0.2
Q425 C	4.5	4.5	4.5	4.7	4.5
Q426 C	0.8	0.7	0.7	0.7	0
Q429 B	0.1	0.4	0.4	0.1	0.1
E	0	-1.2	-1.2	0.4	0.4
Q432 B	-0.3	-3.4	-2.7	-0.1	-3.9
C	11.9	11.8	11.8	12.0	11.6
Q433 B	0	0	0	0	2.7
C	3.0	3.0	3.0	4.5	0
Q434 B	-0.1	0	0	-0.1	0.4
C	3.6	4.5	4.8	2.9	0
Q441 G	-1.1	1.7	-4.8	0	-0.7
D	2.0	-8.1	1.9	1.8	2.0
S	2.0	1.6	1.9	1.8	2.0
Q442 B	1.3	1.1	1.1	1.1	2.1
E	0.9	0.7	0.7	0.7	1.5
Q444 C	1.2	1.2	1.4	2.2	1.3
Q445 C	0.4	1.4	1.3	0.3	0.4

A BOARD IC305 M51279FP

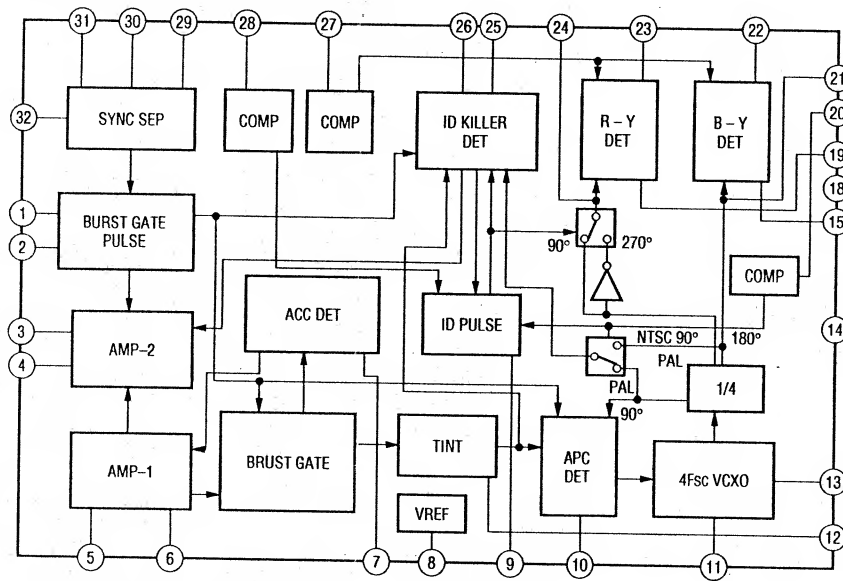

A (2/3) BOARD * MARK VOLTAGE

	PAL	NTSC 3.58	NTSC 4.43	S-VIDEO	ANALOG RGB
IC302 ①	2.9	2.9	0.3	2.9	2.9
②	5.3	4.5	4.5	4.5	4.5
③	10.5	0	0	0	0
IC304 ④	2.2	2.2	2.2	2.2	2.2
⑤	9.4	9.4	9.4	9.4	9.4
⑥	7.3	2.5	2.5	2.6	2.5
⑦	7.3	2.5	2.6	2.6	2.5
⑧	1.9	2.2	2.2	2.2	2.2
⑨	2.5	2.2	2.2	2.3	2.2
IC305 ⑩	2.8	2.8	0	2.8	2.8
⑪	2.5	2.5	2.4	2.4	1.3
⑫	4.1	4.1	4.1	4.2	4.5
⑬	0.4	0	0	0	0.1
⑭	2.6	2.5	2.4	2.5	2.7
⑮	0	0.8	0.8	0.9	0.9
⑯	2.1	1.9	1.9	1.9	2.7
IC306 ⑰	8.1	8.1	8.1	8.1	0
⑱	0	0	0.1	0.1	4.4
IC309 ⑲	3.6	3.6	3.6	3.6	3.6
⑳	0	0	0	0	4.4
IC310 ㉑	6.2	6.2	6.2	6.2	5.9
㉒	6.3	6.2	6.2	6.2	5.9
㉓	5.9	6.0	6.3	5.9	5.9
IC311 ㉔	6.2	6.2	6.2	6.2	5.9
㉕	6.2	6.3	6.2	6.2	5.9
㉖	0.4	0.4	0.4	0.5	0.7
㉗	3.3	2.9	2.9	2.9	0
㉘	5.9	5.9	6.2	5.8	5.9
㉙	0.4	0.4	0.4	0.5	0.7
IC312 ㉚	3.6	3.6	3.6	3.6	3.6
㉛	0	0	12.0	0.1	4.5
IC313 ㉜	0	0	6.3	6.3	6.3
IC314 ㉝	0	7.6	0	3.0	0
㉞	0	0	0	2.9	0.1
IC315 ㉟	0.4	0.4	0.4	0.4	0.6
㊱	0.6	0.6	0.6	0.6	0.6
㊲	9.4	9.3	9.2	9.3	9.4
㊳	2.5	2.5	2.5	2.5	7.2
㊴	0.4	0.4	0.4	0.4	0.6
㊵	0.4	0.4	0.4	0.4	0.6
IC317 ㊶	2.0	2.0	2.1	2.0	12.0
㊷	12.0	12.0	12.0	12.0	12.0
㊸	10.7	10.6	10.6	10.5	10.7
㊹	9.4	9.4	9.4	9.1	9.4
IC318 ㊺	11.5	0	11.4	11.4	11.4
IC320 ㊻	6.3	6.3	6.3	6.3	0
㊼	3.0	0	3.1	0	0
㊽	0	0	0	3.3	0
IC321 ㊾	0	0.1	0	2.9	0
㊿	0	0	0	0.1	2.7
IC322 ①	5.8	6.0	6.3	5.9	5.9
IC323 ②	6.2	6.2	6.2	6.2	5.9
③	0	5.6	5.6	5.6	5.6
IC324 ④	6.2	6.2	6.2	6.2	5.9
IC326 ⑤	5.9	6.0	6.3	5.9	5.9
⑥	5.9	5.9	6.2	5.8	5.9
⑦	5.9	5.9	6.2	5.8	5.9
⑧	1.7	1.6	1.6	2.1	2.1
⑨	2.4	2.3	2.3	2.3	4.6

	PAL	NTSC 3.58	NTSC 4.43	S-VIDEO	ANALOG RGB
IC326 ⑩	0	10.8	0	-0.1	0
⑪	6.3	6.3	6.3	6.2	5.9
⑫	6.3	6.3	6.3	6.2	5.9
⑬	6.3	6.2	6.2	6.2	5.9
⑭	6.2	6.2	6.2	6.2	5.9
⑮	6.2	6.2	6.3	6.2	5.9
⑯	6.2	6.2	6.2	6.2	5.9
IC350 ⑰	6.6	6.4	6.3	6.1	6.9
⑱	6.2	6.2	6.3	6.0	6.4
⑲	6.2	6.2	6.3	6.0	6.4
Q300 ⑳	2.5	2.2	2.2	2.2	2.2
C	10.2	10.4	10.5	10.4	10.5
E	1.9	1.6	1.6	1.6	1.6
Q301 E	8.6	8.2	8.3	8.5	9.8
Q303 E	5.7	5.7	5.7	5.5	5.7
Q304 B	6.3	6.3	6.4	6.2	6.3
E	5.7	5.7	5.7	5.5	5.7
Q305 B	8.6	8.2	8.3	8.5	9.8
E	7.9	7.6	7.7	7.9	9.1
Q307 E	1.4	1.1	1.2	1.4	2.7
Q309 B	1.4	1.1	1.2	1.4	2.6
C	0.1	0.2	0.1	0.1	0
E	0.7	1.7	1.8	0	1.8
Q312 B	0.7	1.7	1.8	0	1.8
C	8.2	8.6	8.3	8.3	8.1
Q313 B	8.2	8.6	8.3	8.2	8.1
C	3.3	2.9	3.1	3.2	3.3
E	8.8	9.3	9.0	8.9	8.7
Q314 B	11.9	11.9	11.9	11.9	11.9
C	0	0	0	0	0
Q315 B	3.3	2.9	3.1	3.2	3.3
E	3.9	3.5	3.8	3.8	4.0
Q318 B	12.1	11.7	11.9	12.1	12.1
C	1.0	1.2	1.0	1.0	0.9
Q322 B	2.4	2.3	2.3	5.6	2.4
E	1.8	1.8	1.8	5.0	1.8
Q323 B	5.0	0	0	0	0
C	0	3.5	3.5	3.5	3.6
Q324 B	4.1	0	0	0	0
C	0	0.8	0.8	0.8	0.9
Q332 B	4.9	0	4.9	0	0
C	0	4.4	0	4.3	4.4
Q333 B	1.7	1.9	1.8	1.7	1.7
E	1.5	1.7	1.5	1.5	1.4
Q336 G	4.7	4.6	4.7	4.2	4.8
D	4.3	4.3	4.3	4.5	4.3
Q339 B	12.3	12.5	12.4	12.5	12.3
Q354 B	12.0	0	0	0	0
E	12.0	0	0	0	-0.2
Q358 E	2.2	0	2.2	2.2	2.2
Q360 1	6.2	6.2	6.3	6.1	6.4
3	6.2	6.2	6.3	6.0	6.4
5	1.3	2.2	4.1	5.3	3.8
Q362 C	9.0	9.0	9.5	9.2	8.5
Q364 C	3.3	2.9	2.9	2.8	2.9
Q365 B	0.4	0.3	0.3	0.4	0.4
Q369 B	0.8	0.8	0.8	0.9	4.9
Q372 B	0	0	0	0	4.9
C	11.7	11.8	11.8	11.7	0

A (2/3) BOARD * MARK LIST

	20INCH MODEL	14INCH MODEL
C1302	390p :CHIP	470p CH:CHIP
Q373	DTC144EKA	#
R354	820k :CHIP	1.2M :CHIP
R2357	#	56k :CHIP
R2367	100k :CHIP	120k :CHIP
R3350	330k :CHIP	820k :CHIP
R3351	560k :CHIP	820k :CHIP
R3353	390k :CHIP	#
R3365	120k :CHIP	#
R3366	68k :CHIP	#
R3367	68k :CHIP	#
R3368	22k :CHIP	#
R3369	47k :CHIP	#
R3380	1M :CHIP	#
R3398	36k RN-CP	27k :RN-CP

A (2/3) BOARD WAVEFORMS

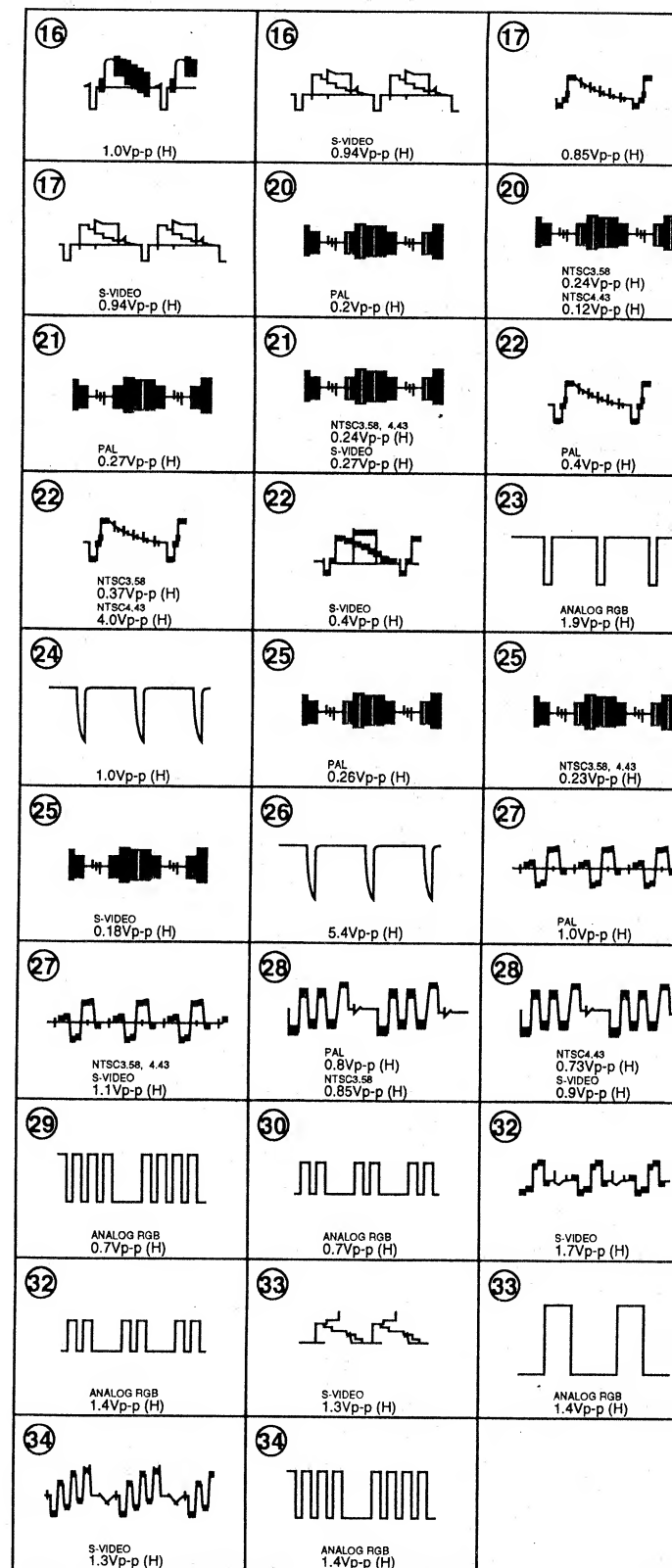

A
B
C
D
E
F
G
H
I
J
K
L
M
N
O
P

BOARD WAVEFORMS

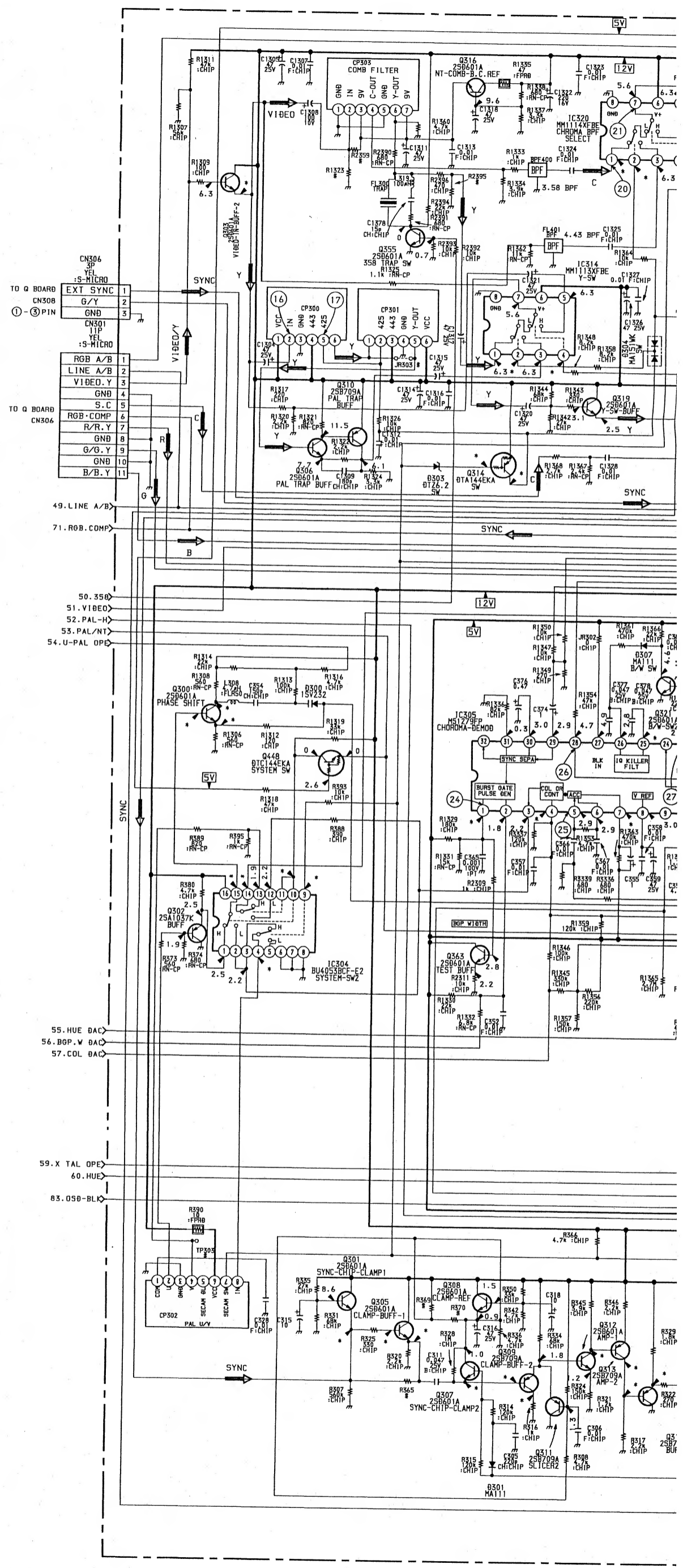
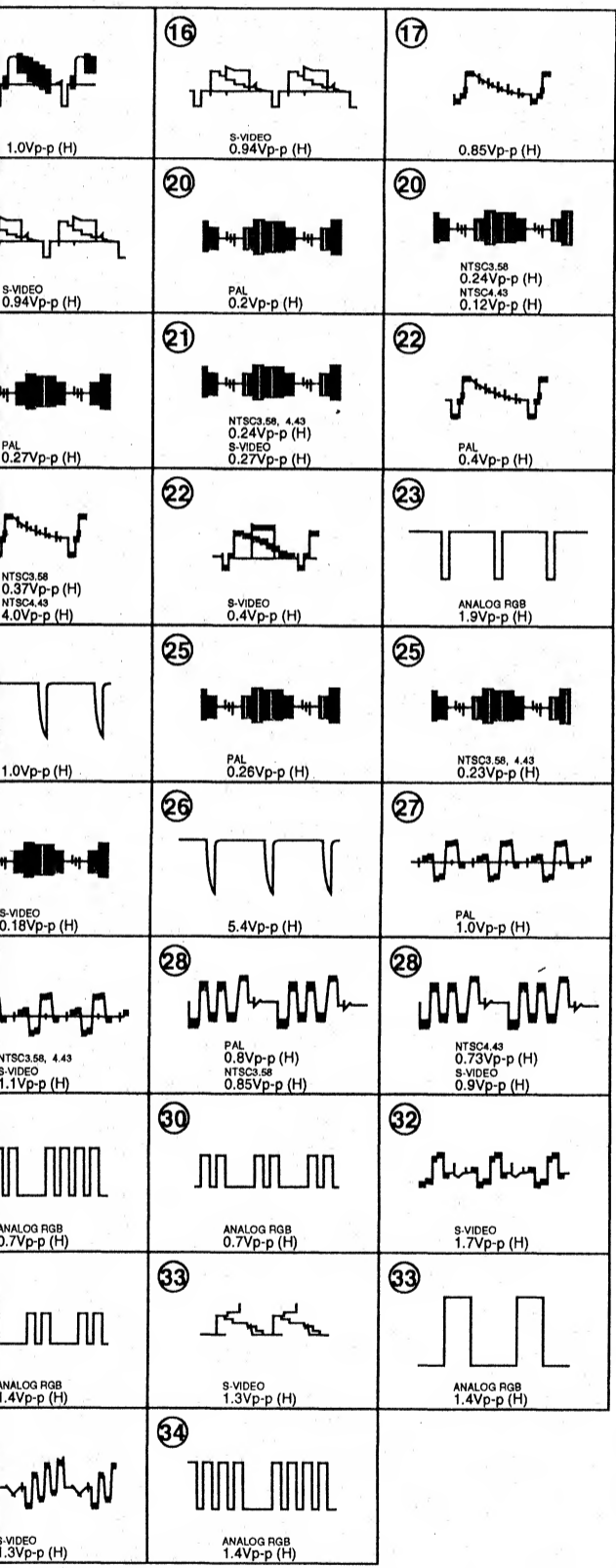

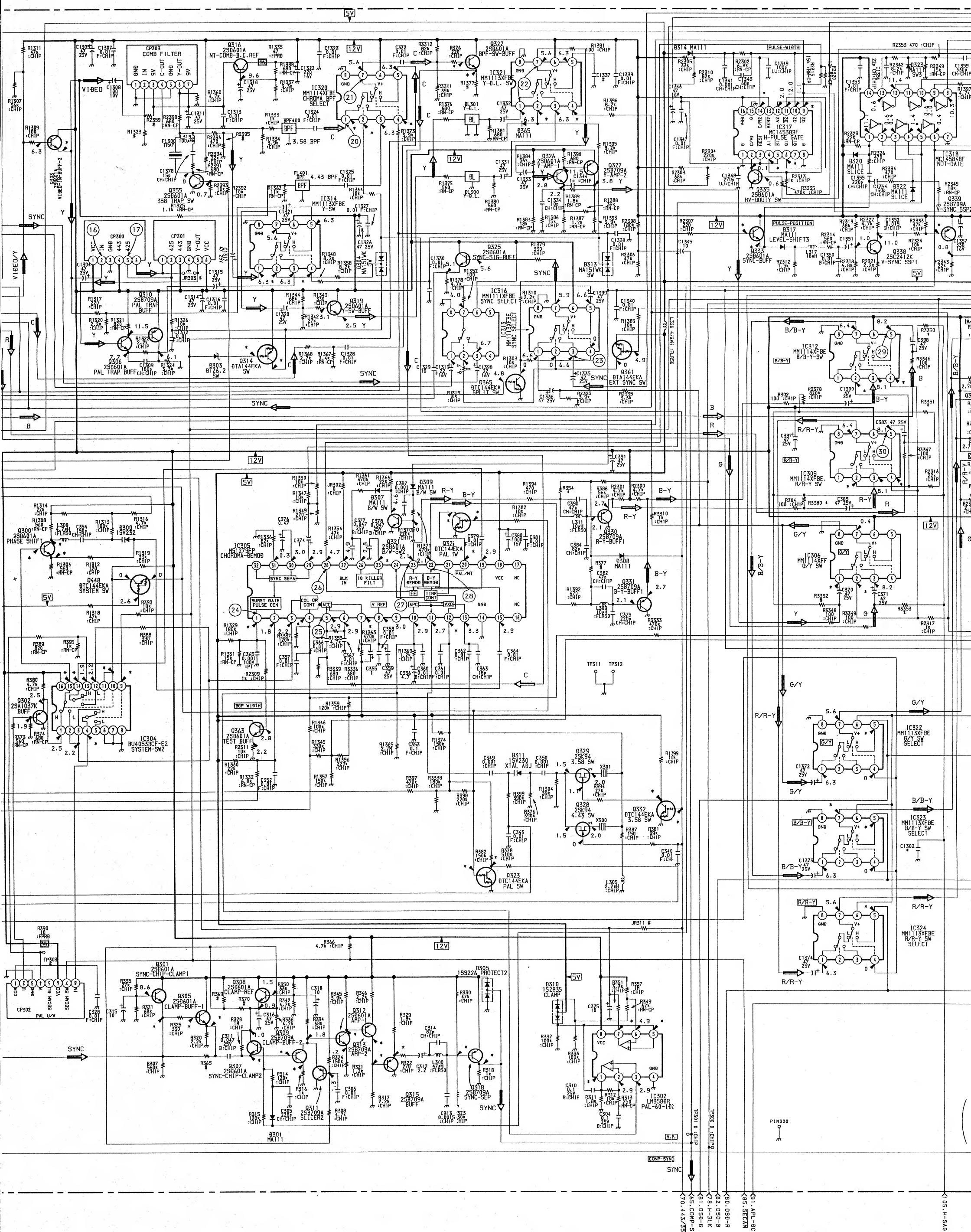

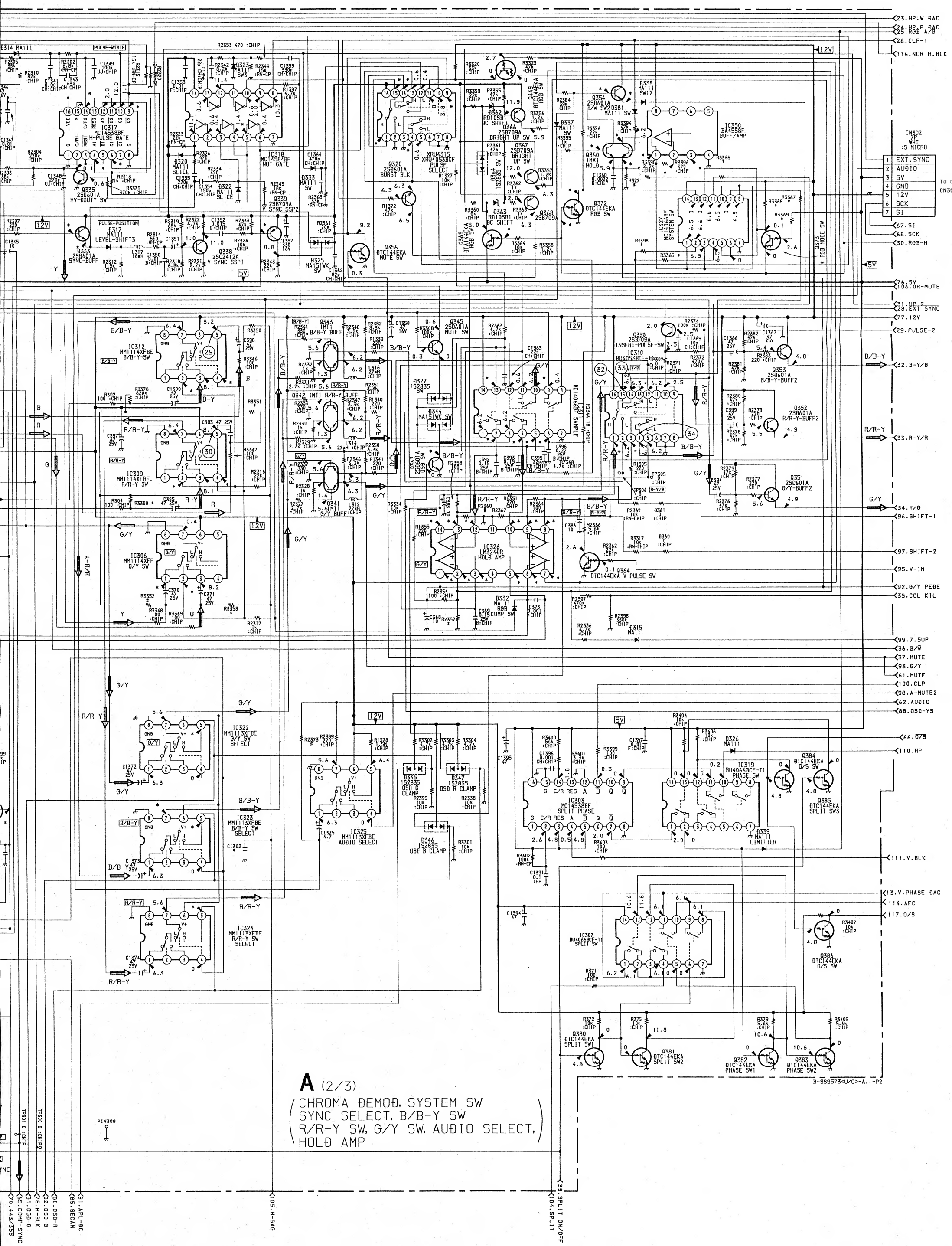

A (2/3)
 (CHROMA DEMOD. SYSTEM SW
 SYNC SELECT, B/B-Y SW
 R/R-Y SW, G/Y SW, AUDIO SELECT,
 HOLD AMP)

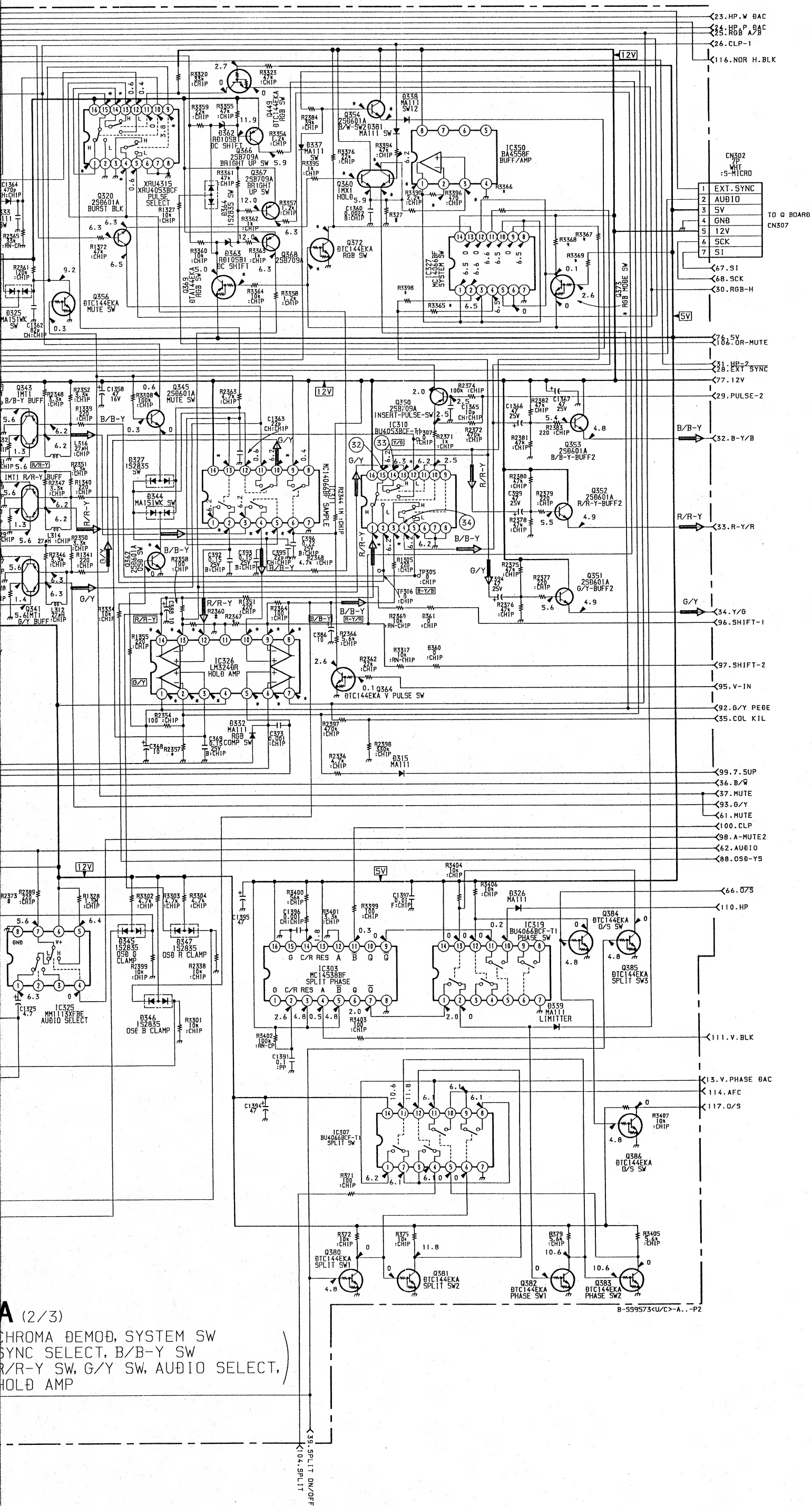

A (2/3)
 CHROMA DEMOD. SYSTEM SW
 SYNC SELECT, B/B-Y SW
 R/R-Y SW, G/Y SW, AUDIO SELECT,
 HOLD AMP

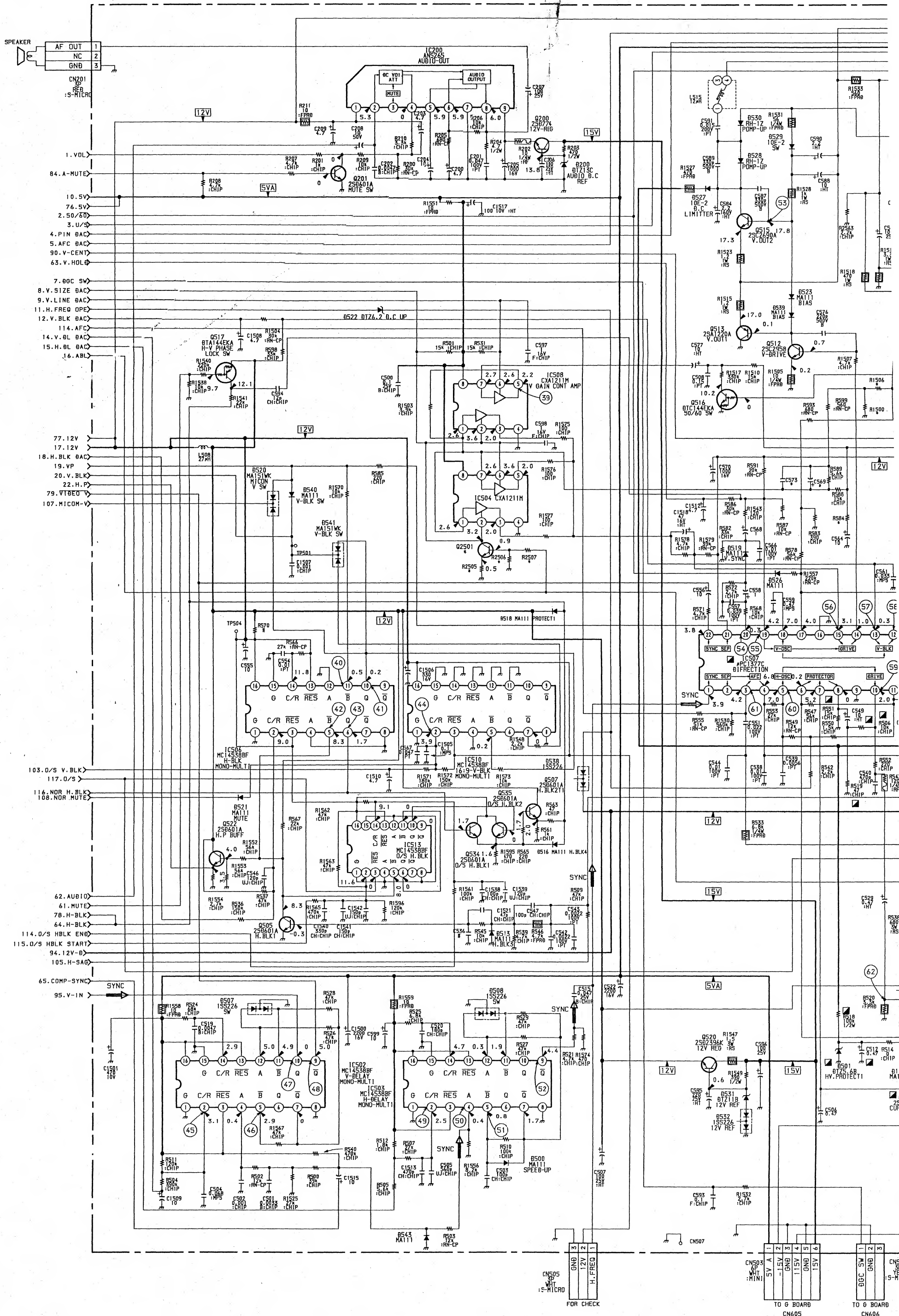

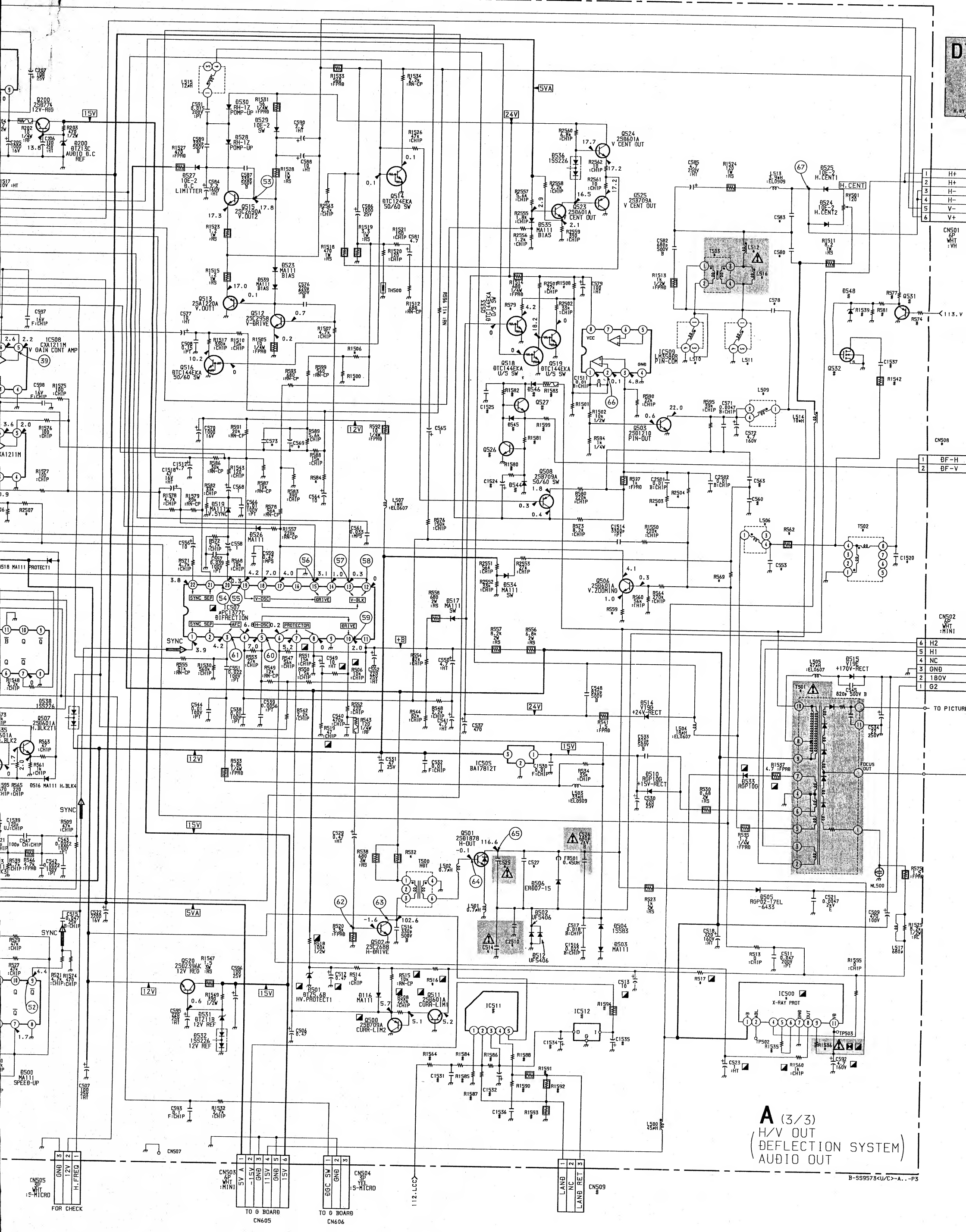

A (3/3)
 H/V OUT
 (DEFLECTION SYSTEM)
 AUDIO OUT

- | | |
|---|----|
| 1 | H+ |
| 2 | H- |
| 3 | H- |
| 4 | H- |
| 5 | V- |
| 6 | V+ |
- CN501
CP
WHT
:VH
- | | |
|---|------|
| 1 | DF-H |
| 2 | DF-V |
- CN508
- | | |
|---|------|
| 6 | H2 |
| 5 | H1 |
| 4 | NC |
| 3 | GND |
| 2 | 180V |
| 1 | G2 |
- TO PICTURE
- | | |
|---|------|
| 1 | WHT |
| 2 | MINI |
- CN502

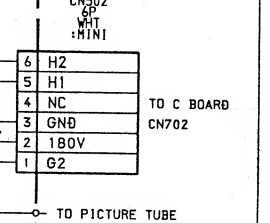
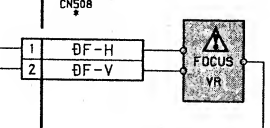
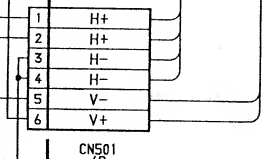
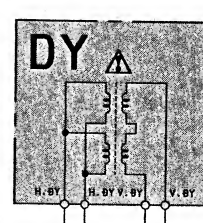
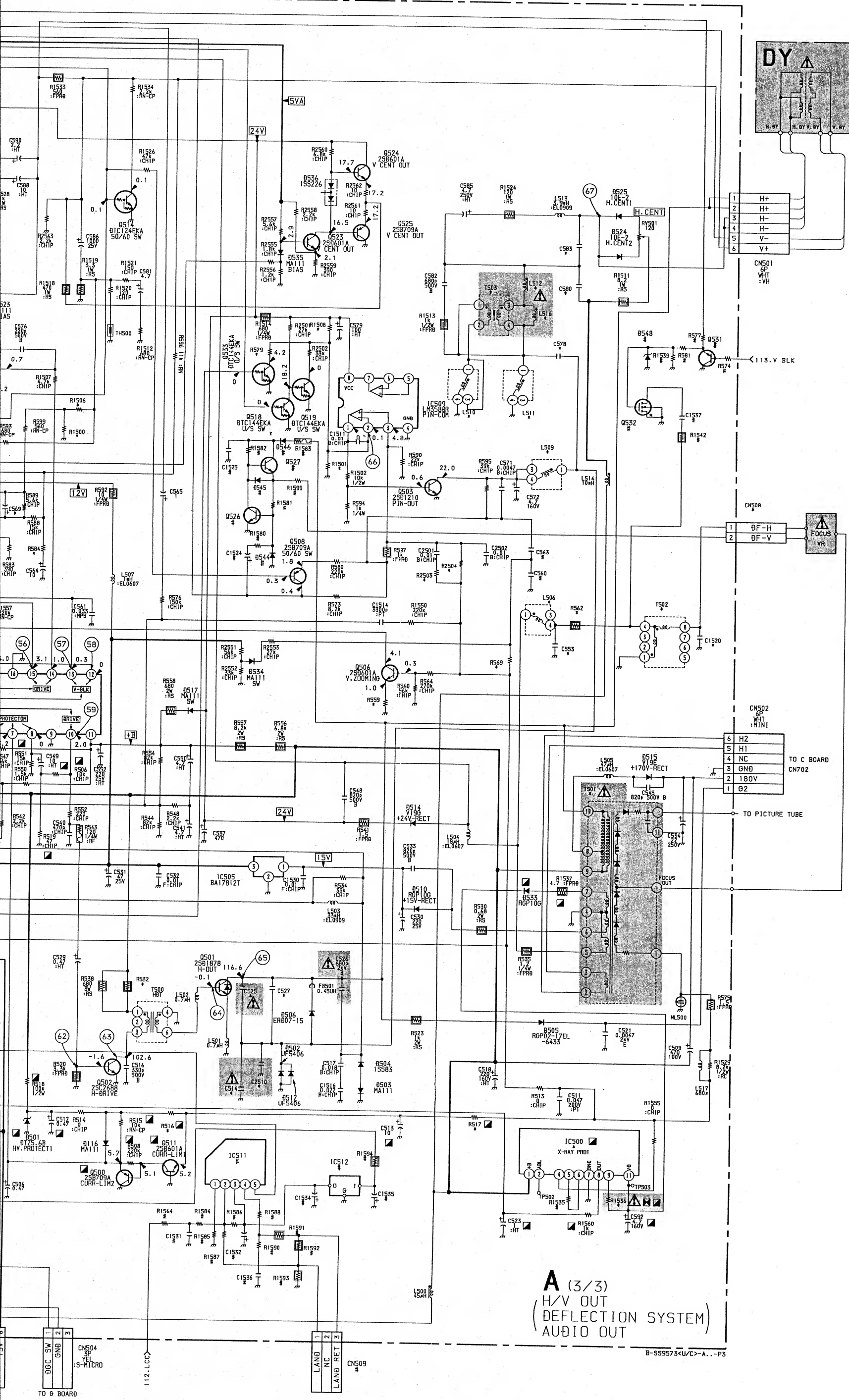

A (3/3)
H/V OUT
(DEFLECTION SYSTEM)
AUDIO OUT

B-S59573(U/C)-A...-P3

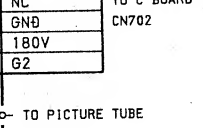
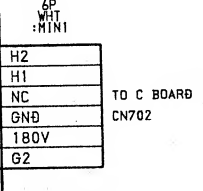
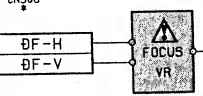
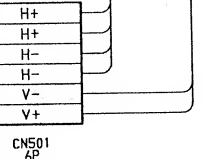
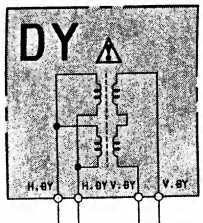
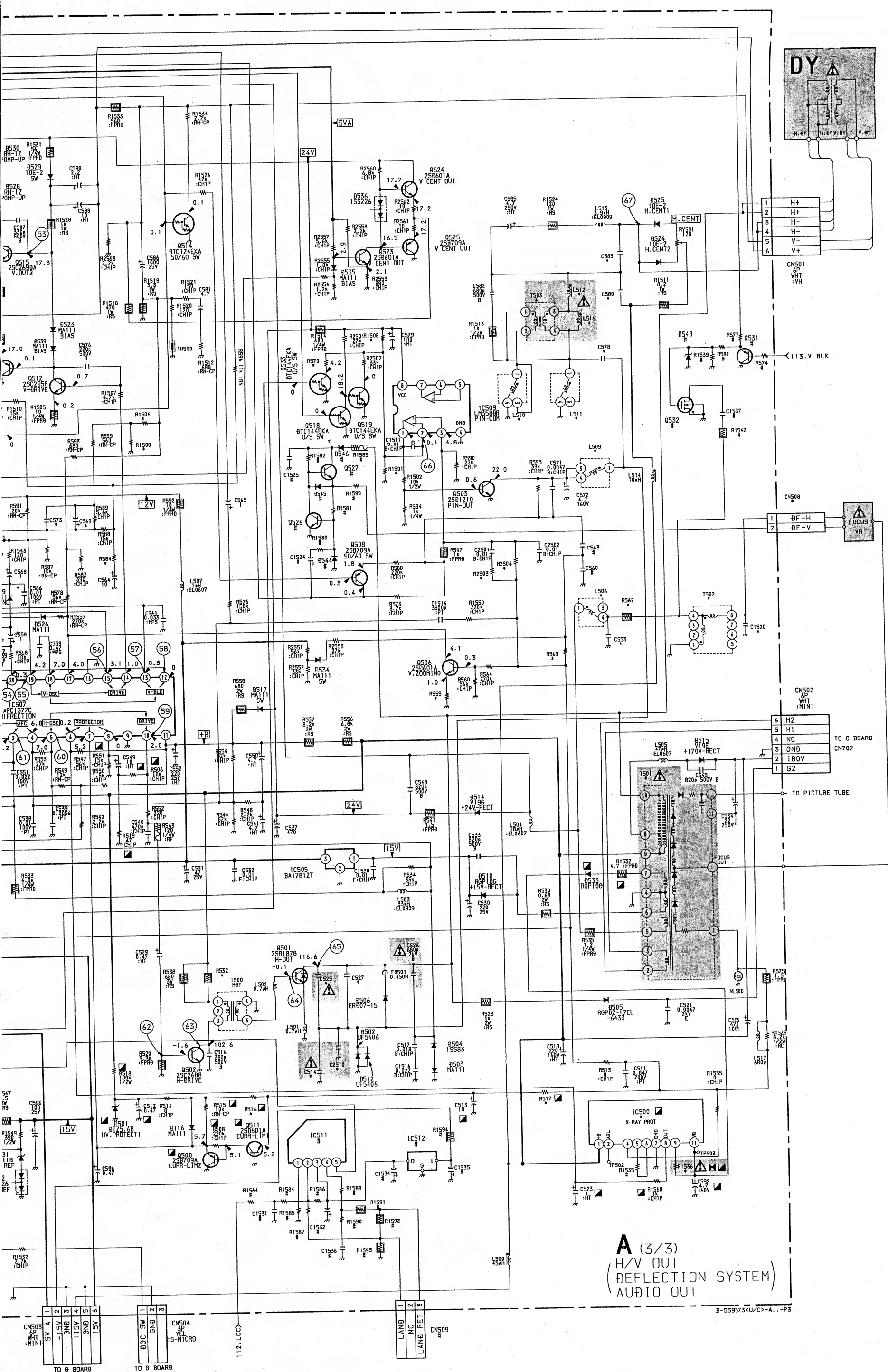

A (3/3)
 H/V OUT
 (DEFLECTION SYSTEM)
 AUDIO OUT

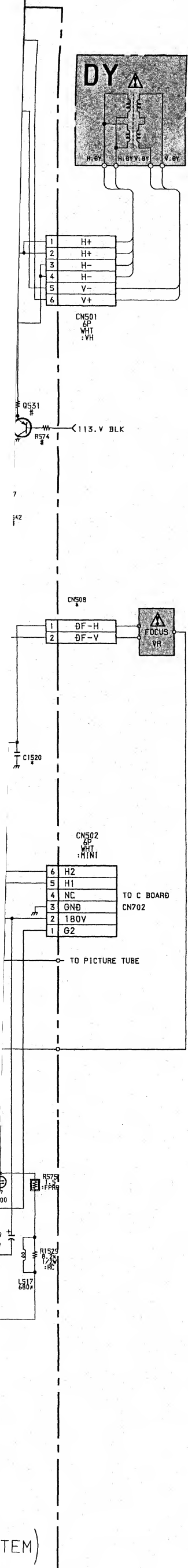

A (3/3) BOARD WAVEFORMS

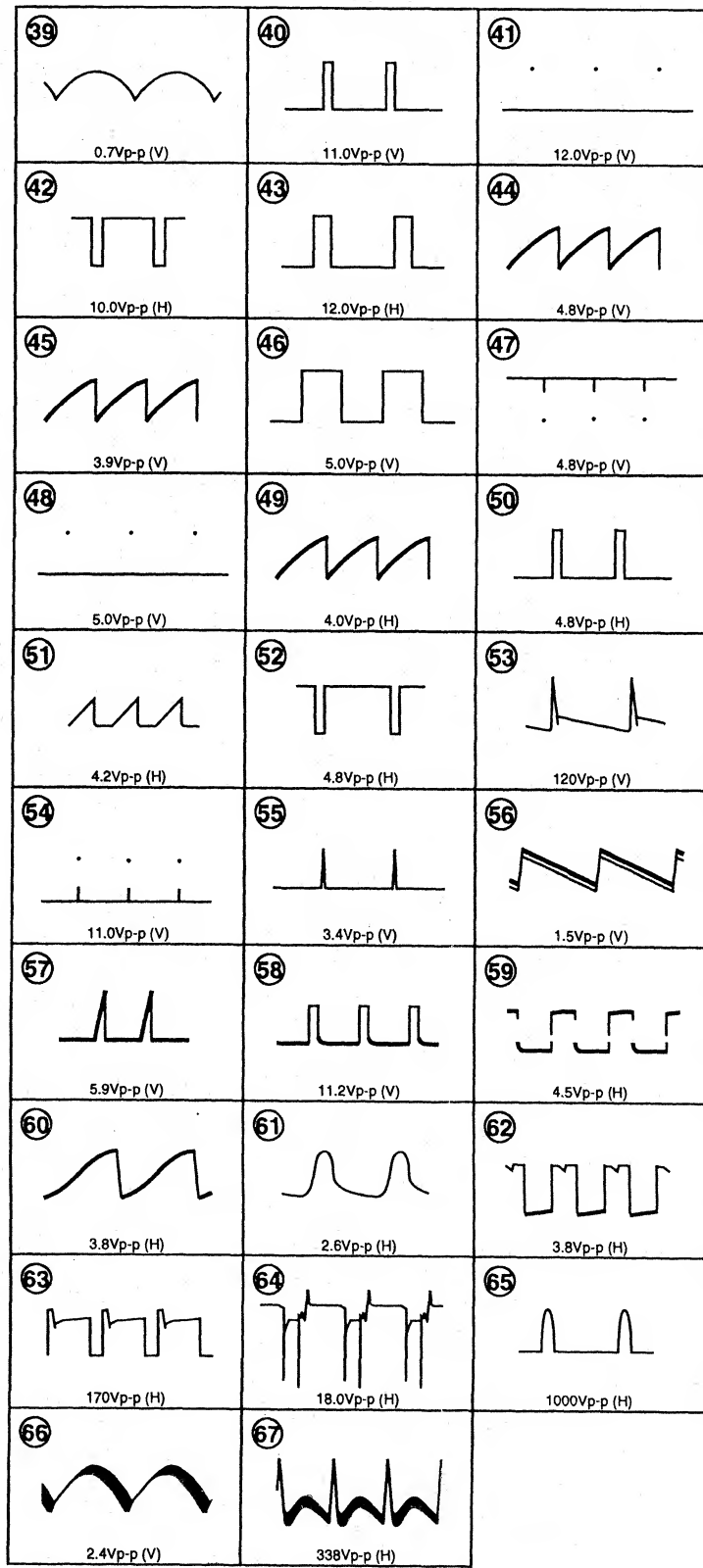

A (3/3) BOARD * MARK LIST

	20INCH MODEL	14INCH MC
C514	0.022 630V :PP	0.01 630V :PP
C525	0.012 2kV :PP	0.01 2kV :PP
C527	#	470p 2kV
C553	0.082 200V :PT	#
C569	3.3 25V :TA	4.7 25V :TA
C573	1 :MPS	0.47 :MPS
C578	1.0 200V :PP	1.4 200V :PP
C580	0.33 200V :PP	0.24 200V :PP
C583	1.5 200V :PP	1.8 200V :PP
C1520	150p 2kV B	#
C2510	#	0.0015 630V :P
CN508	2P WHT :MINI	#
IC500	H8D7249	H8D7248
L506	COIL, DUST CORE	#
L509	HCC	DYNAMIC CONV
L510	:PMC	#
L511	#	COIL
L512	90μH	45μH
L516	#	:HLC
Q2501	2SD601A	#
R516	100k :CHIP	180k :CHIP
R517	20k 1/2W :RN	10k 1/2W :RN
R532	680 3W :RS	3.3k 3W :RS
R559	330k :CHIP	220k :CHIP
R562	22 1/4W :FPRD	#
R569	47k 1/2W	18k 1/2W
R579	15k :CHIP	22k :CHIP
R584	10k :CHIP	8.2k :CHIP
R1500	820 :RN-CP	680 :RN-CP
R1501	8.2k :CHIP	12k :CHIP
R1506	470 :CHIP	220 :CHIP
R1508	39k :CHIP	27k :CHIP
R1596	62k :RN-CP	75k :RN-CP
R2503	100k :CHIP	47k :CHIP
R2504	150k :CHIP	100k :CHIP
R2505	470k :CHIP	#
R2506	120k :CHIP	#
R2507	220k :CHIP	#
T501	1-453-234-11	1-453-233-11
T502	DFT	#
T503	HLC	#

A (3/3) BOARD WAVEFORMS

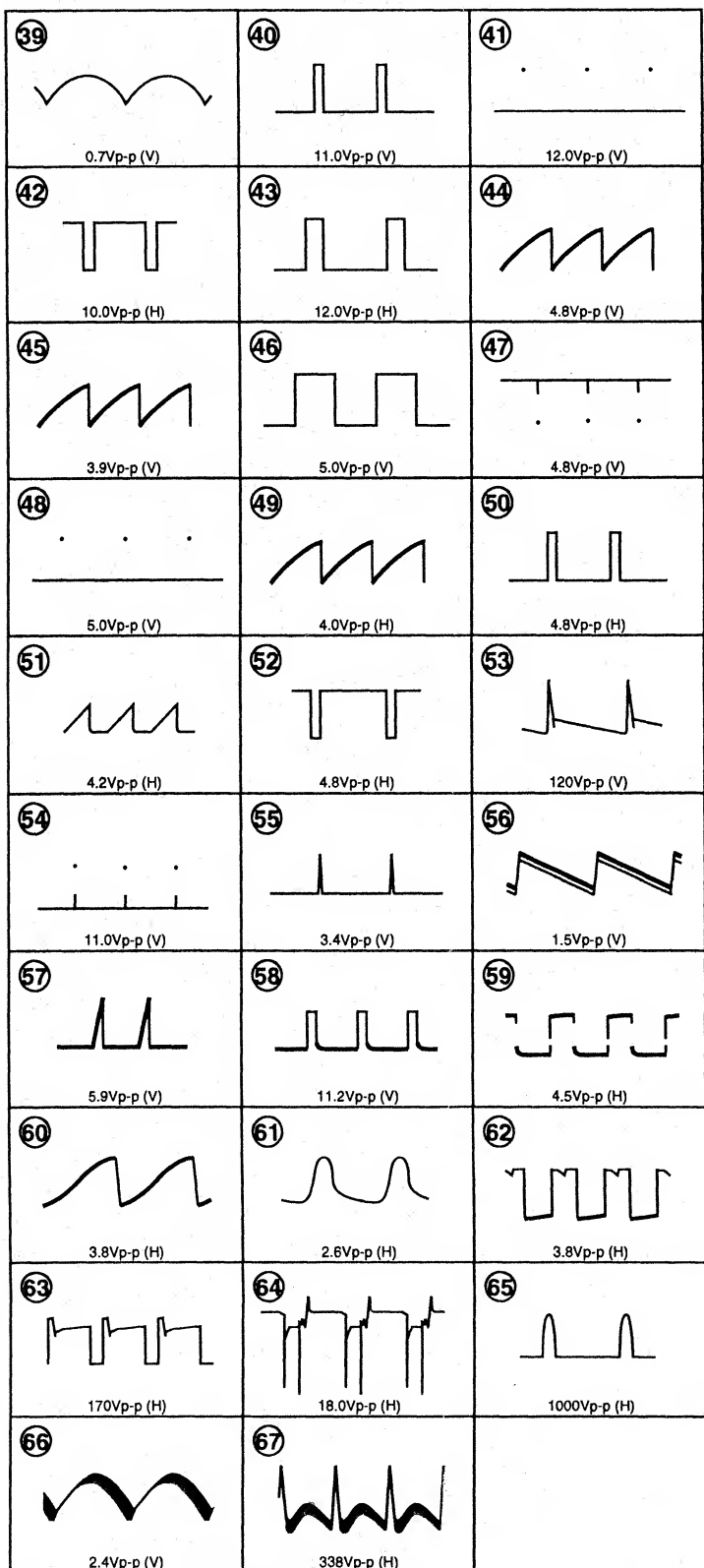

A (3/3) BOARD * MARK LIST

	20INCH MODEL	14INCH MODEL
C514	0.022 630V :PP	0.01 630V :PP
C525	0.012 2kV :PP	0.01 2kV :PP
C527	#	470p 2kV
C553	0.082 200V :PT	#
C569	3.3 25V :TA	4.7 25V :TA
C573	1 :MPS	0.47 :MPS
C578	1.0 200V :PP	1.4 200V :PP
C580	0.33 200V :PP	0.24 200V :PP
C583	1.5 200V :PP	1.8 200V :PP
C1520	150p 2kV B	#
C2510	#	0.0015 630V :PP
CN508	2P WHT :MINI	#
IC500	H8D7249	H8D7248
L506	COIL, DUST CORE	#
L509	HCC	DYNAMIC CONVERSION
L510	:PMC	#
L511	#	COIL
L512	90μH	45μH
L516	#	:HLC
Q2501	2SD601A	#
R516	100k :CHIP	180k :CHIP
R517	20k 1/2W :RN	10k 1/2W :RN
R532	680 3W :RS	3.3k 3W :RS
R559	330k :CHIP	220k :CHIP
R562	22 1/4W :FPRD	#
R569	47k 1/2W	18k 1/2W
R579	15k :CHIP	22k :CHIP
R584	10k :CHIP	8.2k :CHIP
R1500	820 :RN-CP	680 :RN-CP
R1501	8.2k :CHIP	12k :CHIP
R1506	470 :CHIP	220 :CHIP
R1508	39k :CHIP	27k :CHIP
R1536	62k :RN-CP	75k :RN-CP
R2503	100k :CHIP	47k :CHIP
R2504	150k :CHIP	100k :CHIP
R2505	470k :CHIP	#
R2506	120k :CHIP	#
R2507	220k :CHIP	#
T501	1-453-234-11	1-453-233-11
T502	DFT	#
T503	HLC	#

A
B
C
D
E
F
G
H
I
J
K
L
M
N
O
P

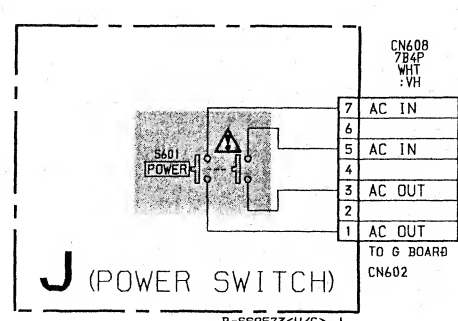
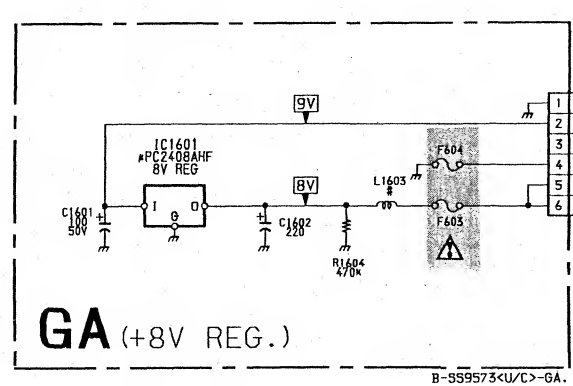
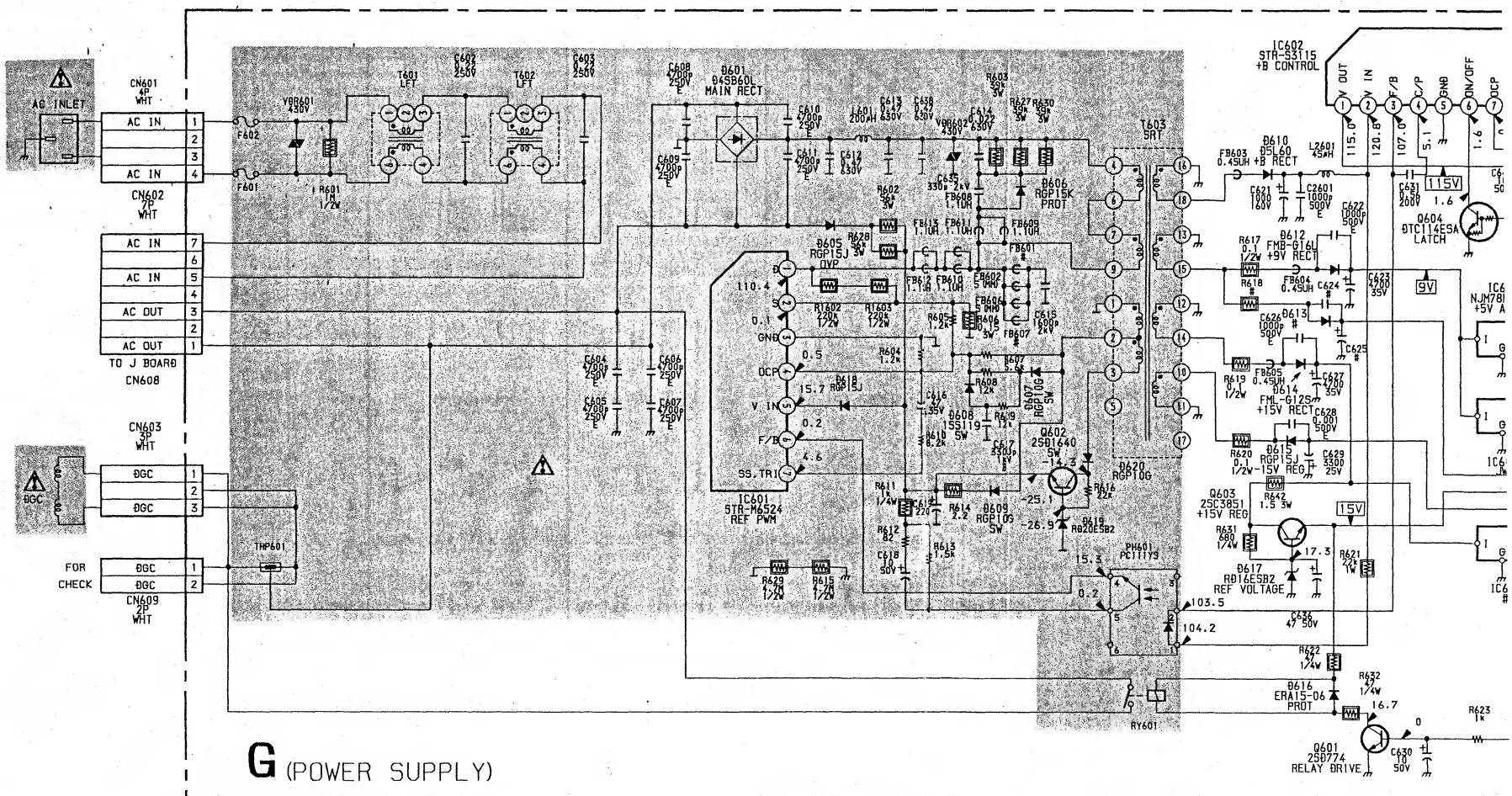
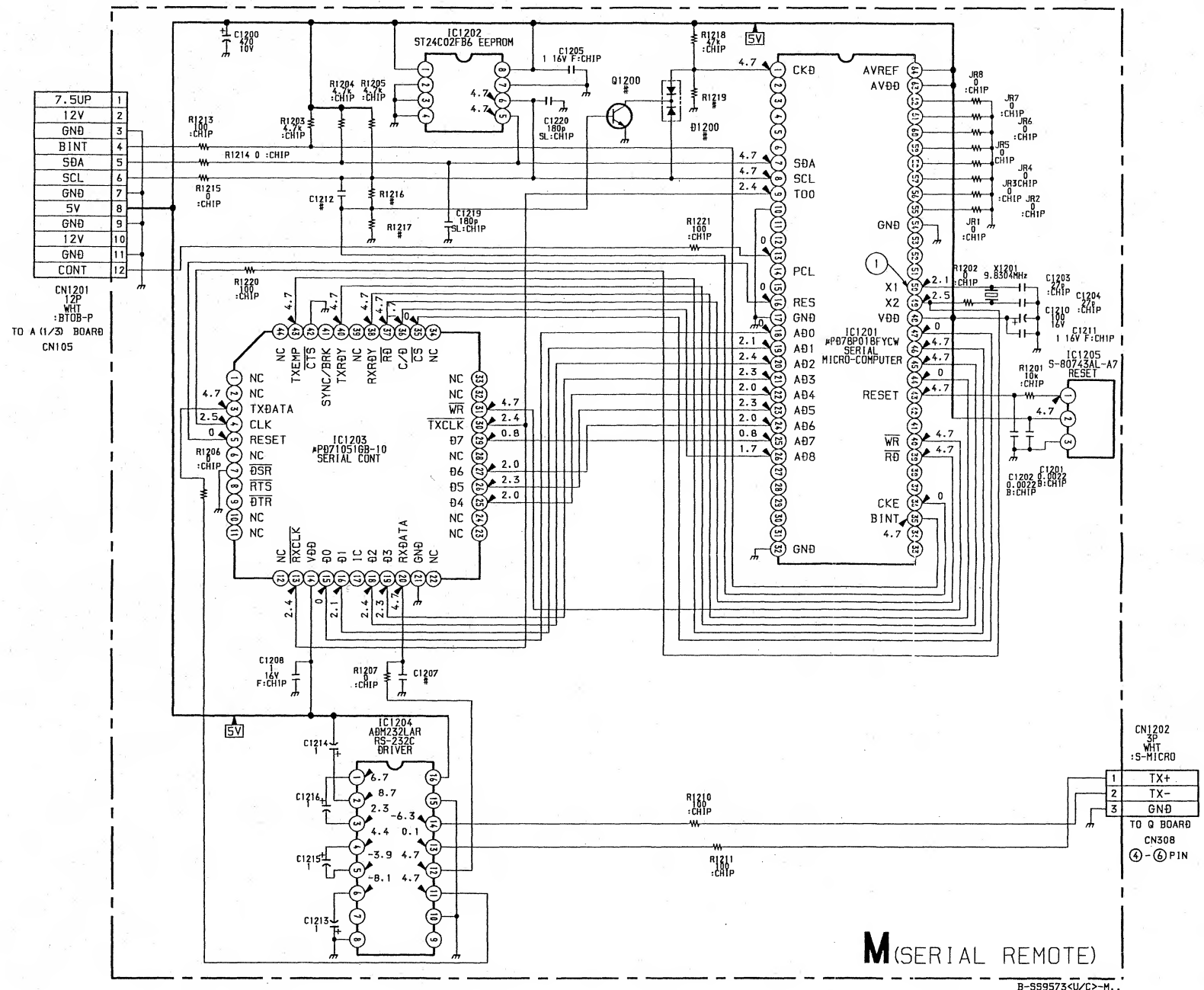
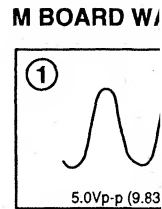

M BOARD WAVEFORM

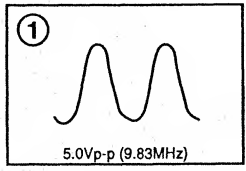

Q BOARD WAVEFORMS

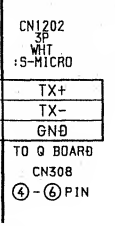
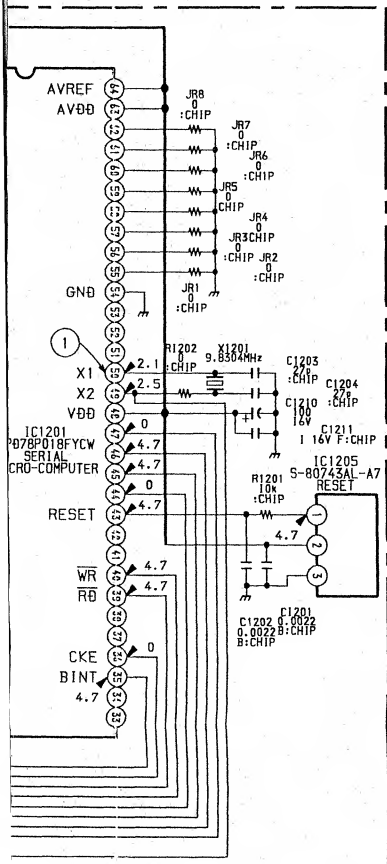
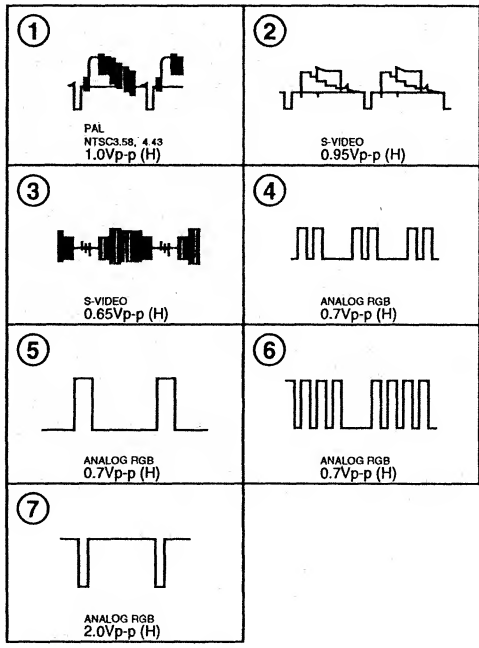

M (SERIAL REMOTE)

B-559573<U/C>-M..

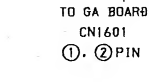
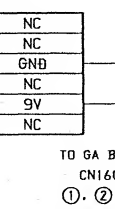
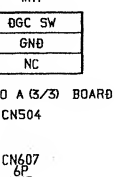
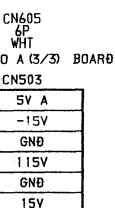
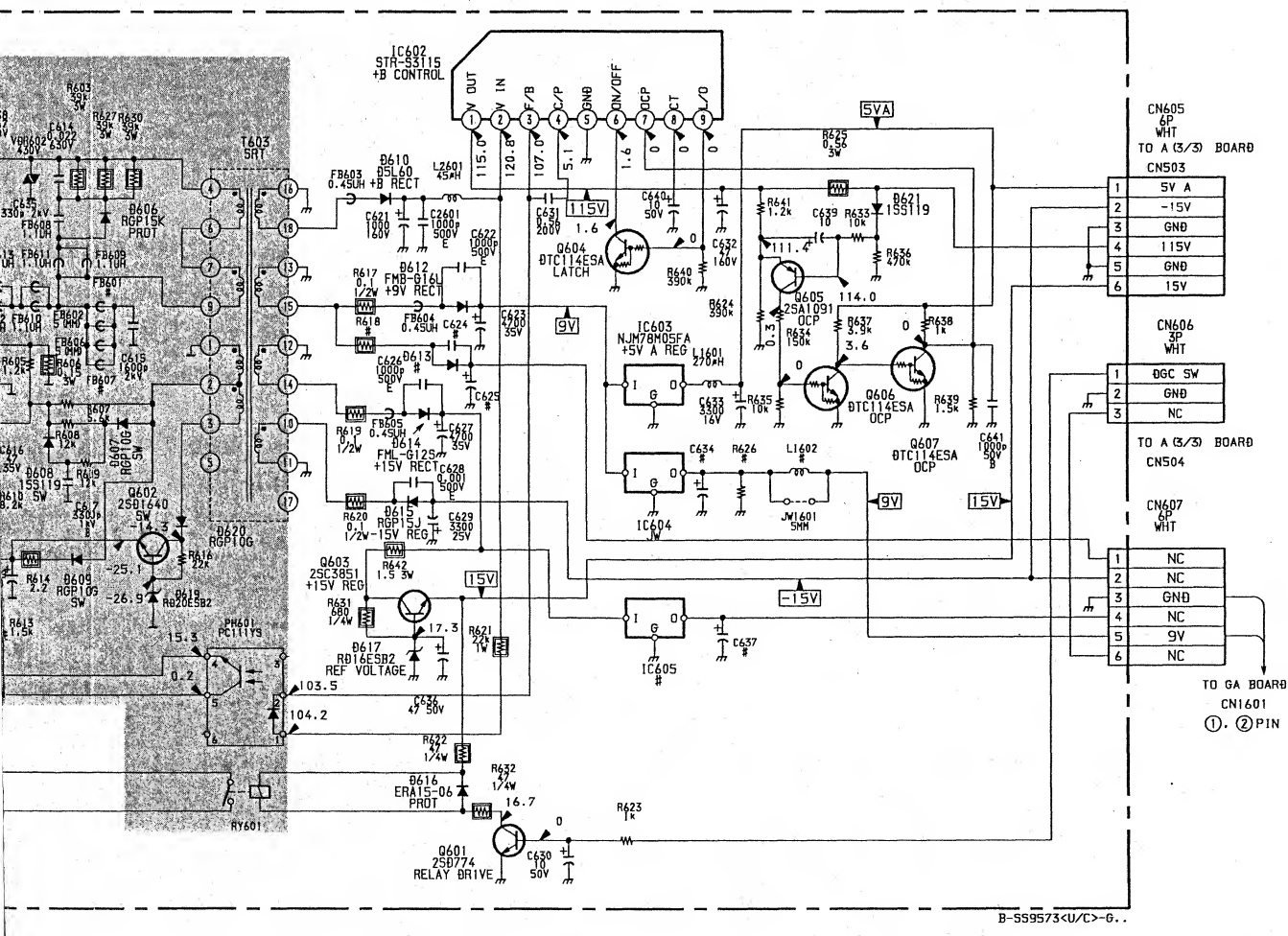

B-559573<U/C>-G..

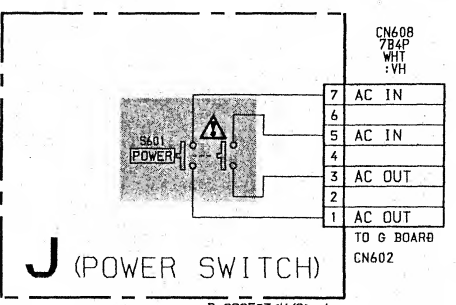

B-559573<U/C>-J..

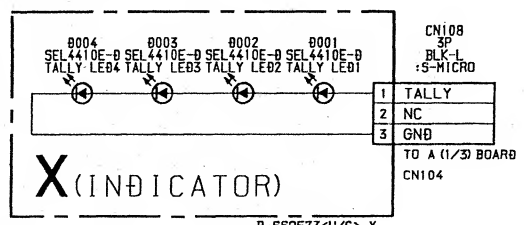

B-559573<U/C>-X..

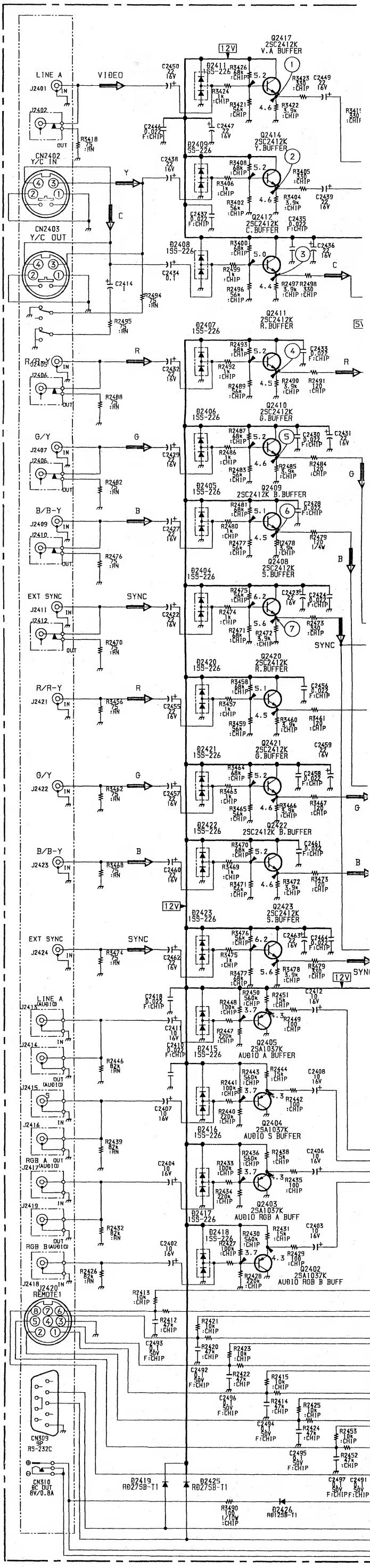

WAVEFORM

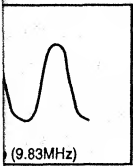

Q BOARD WAVEFORMS

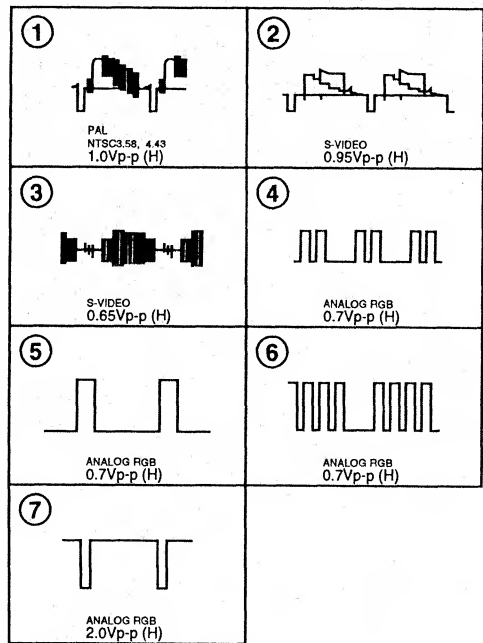

Q (SIGNAL IN/OUT, AUDIO IN/OUT)

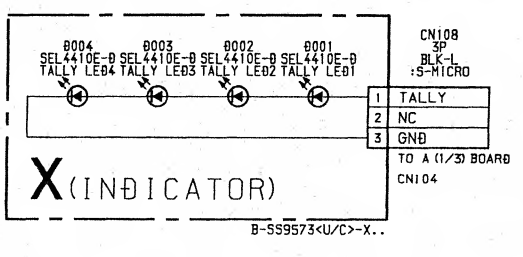
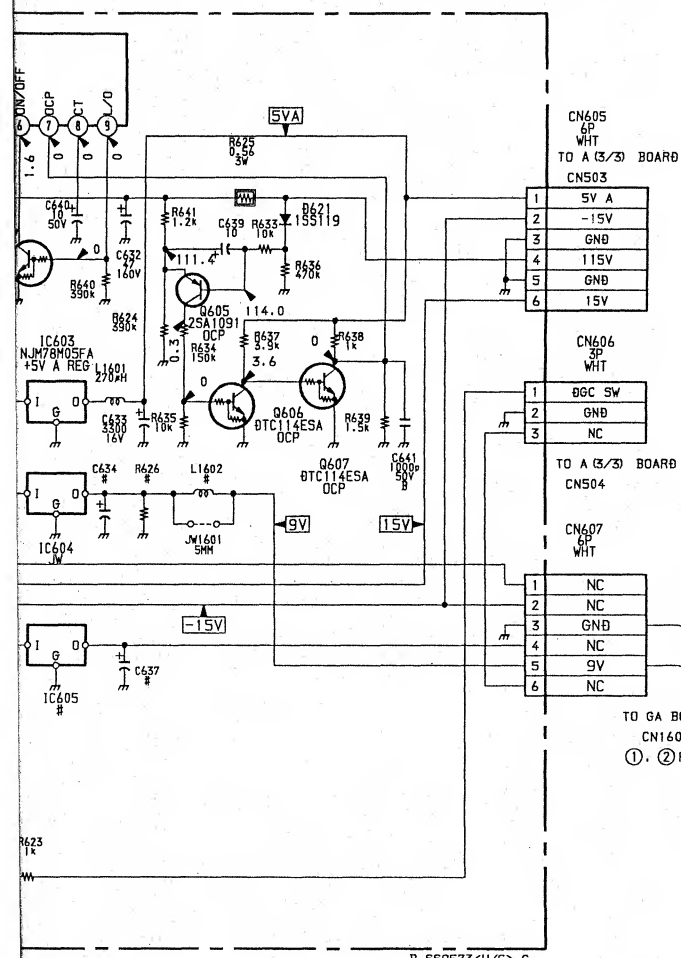
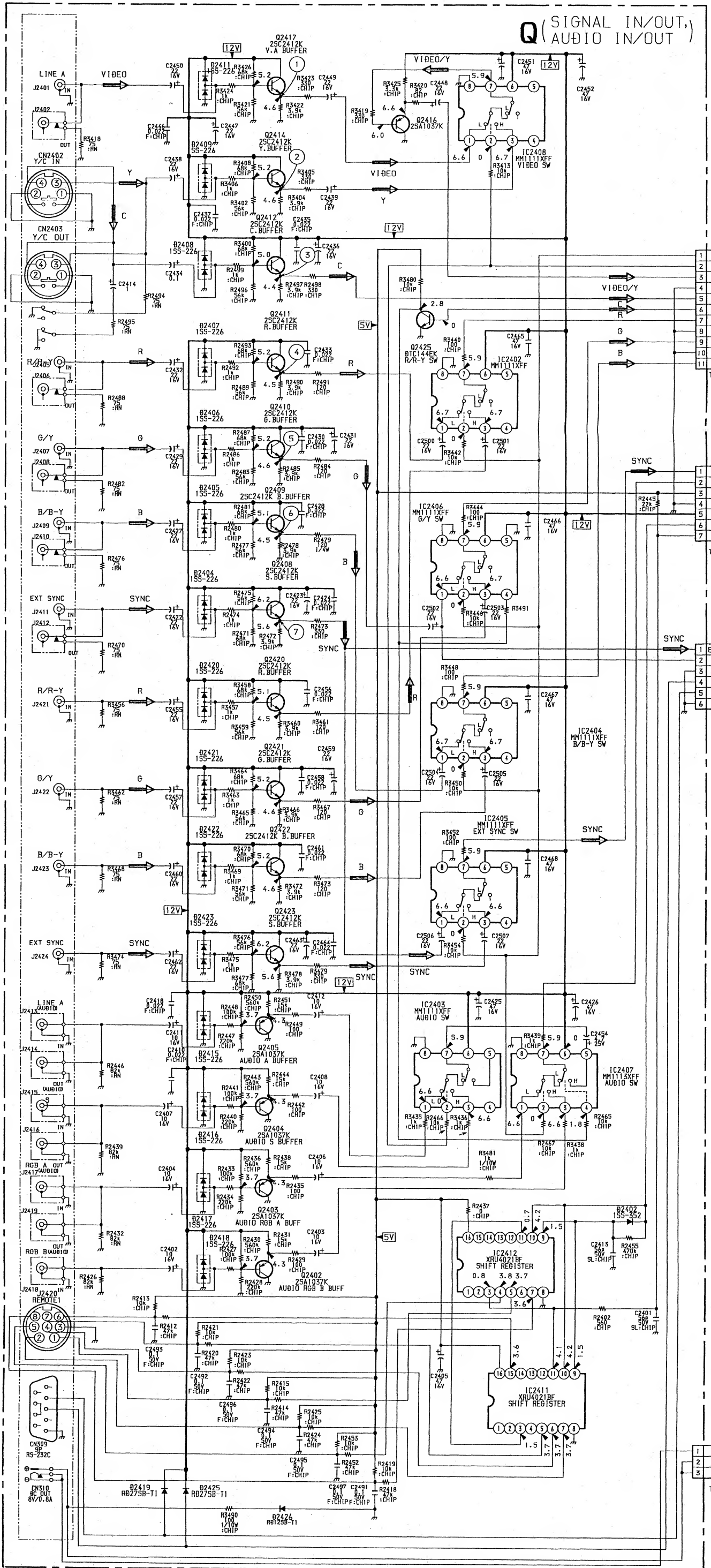

BOARD WAVEFORM

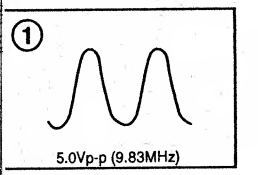

Q BOARD WAVEFORMS

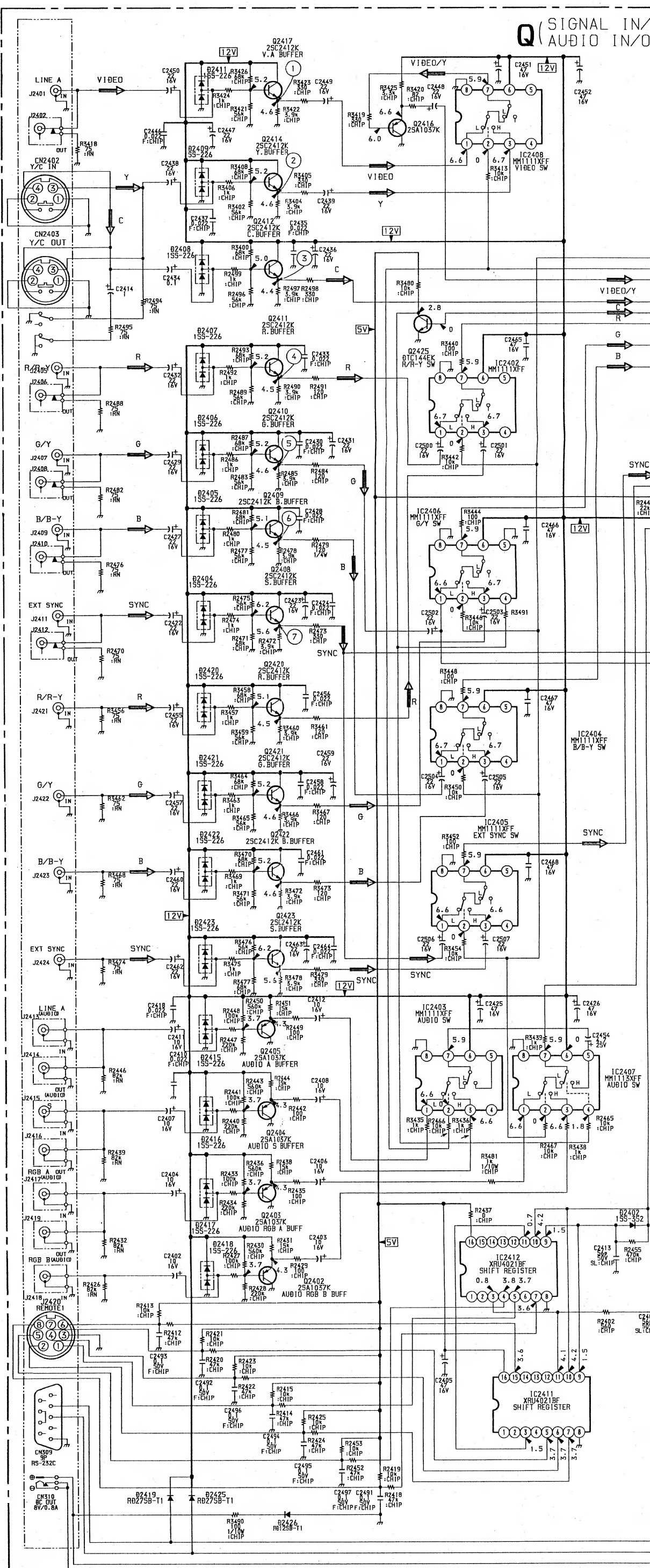
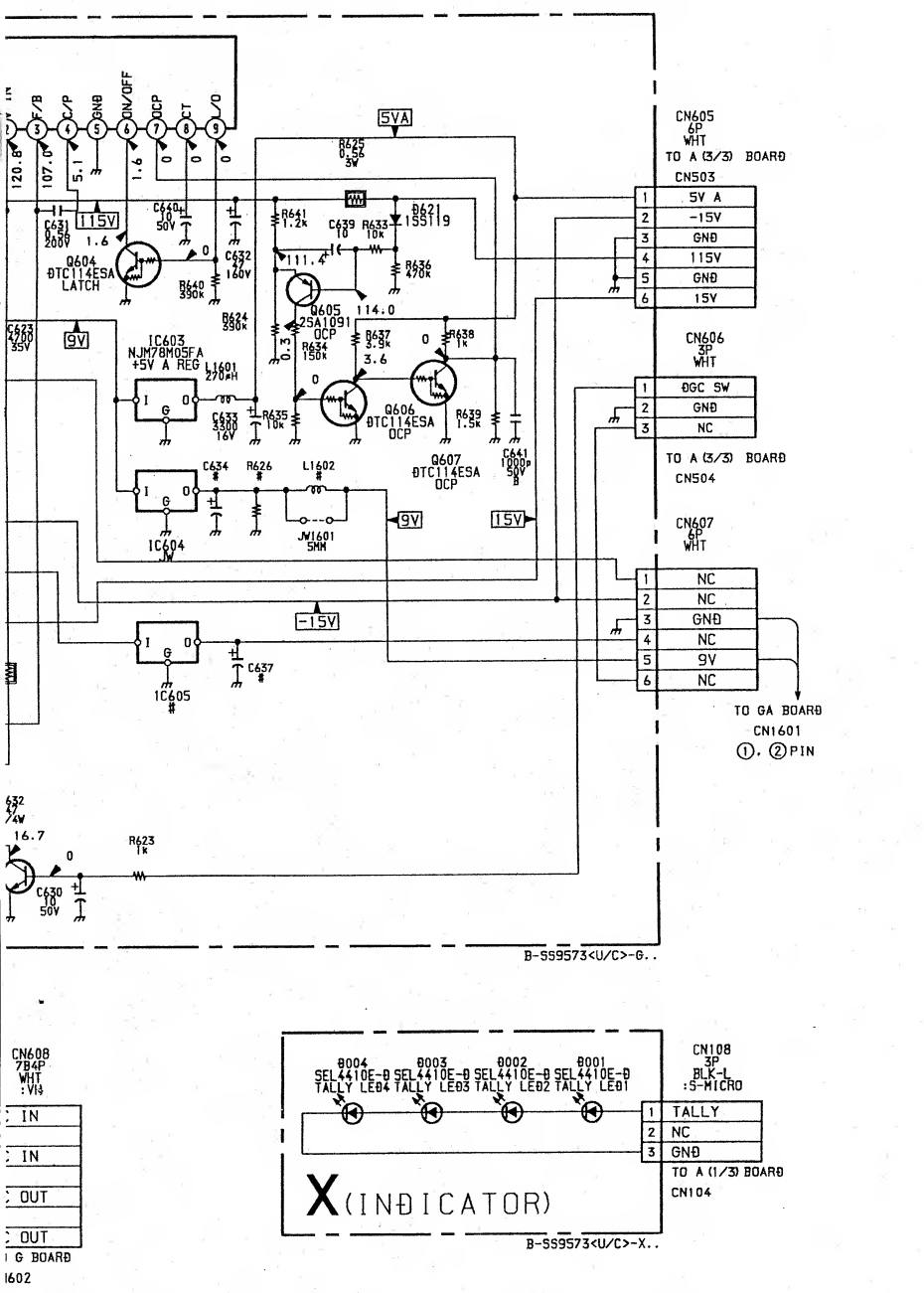
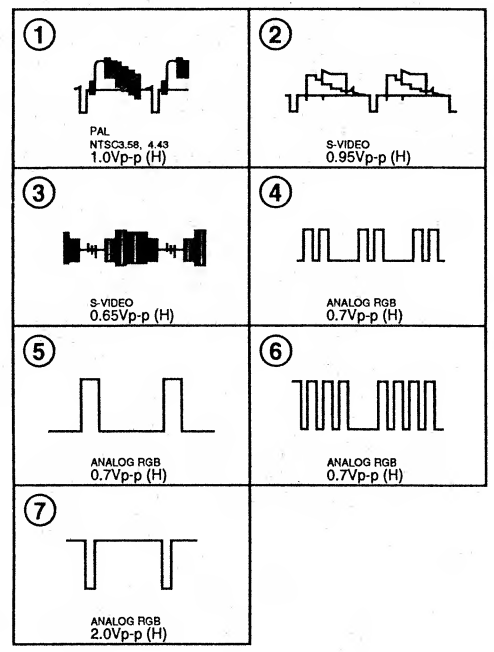

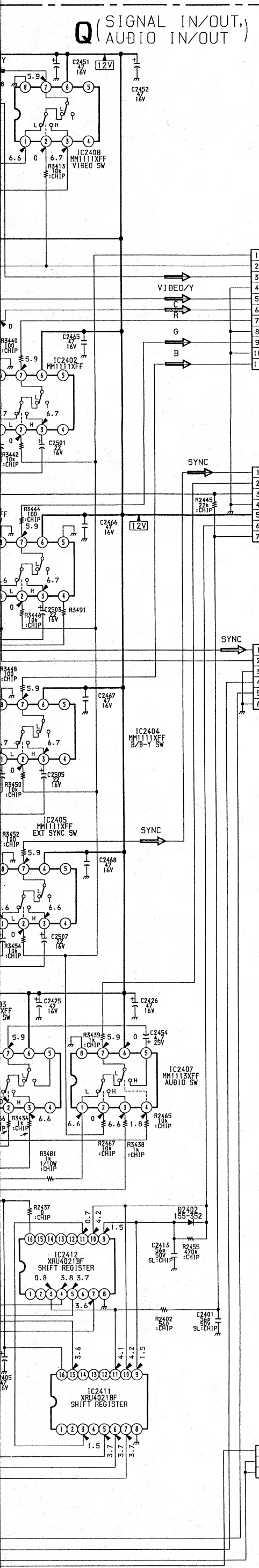

U/C MODEL ONLY

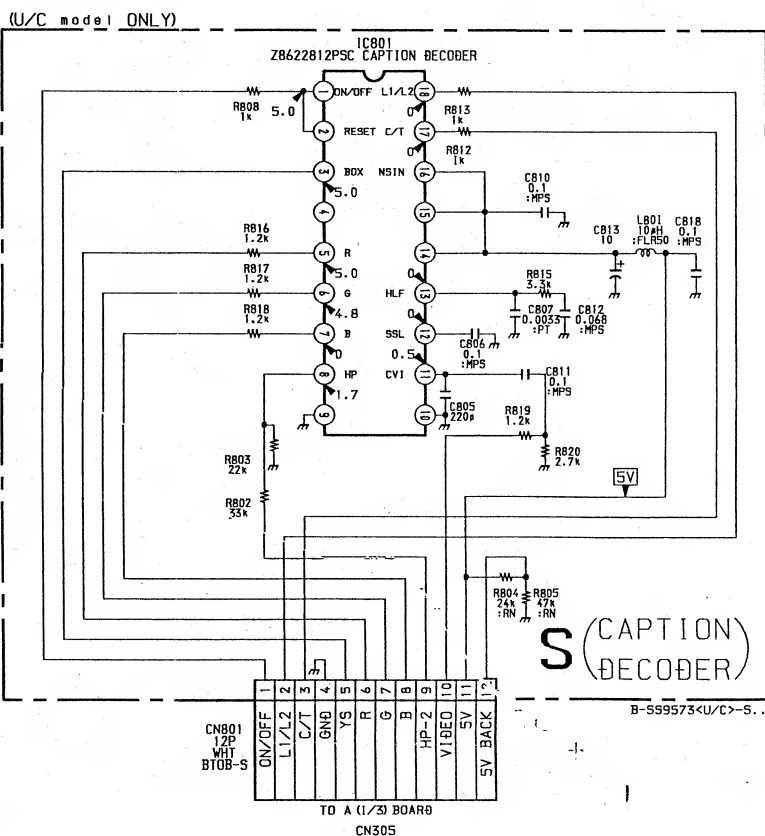

S BOARD IC801 Z8622812PSC

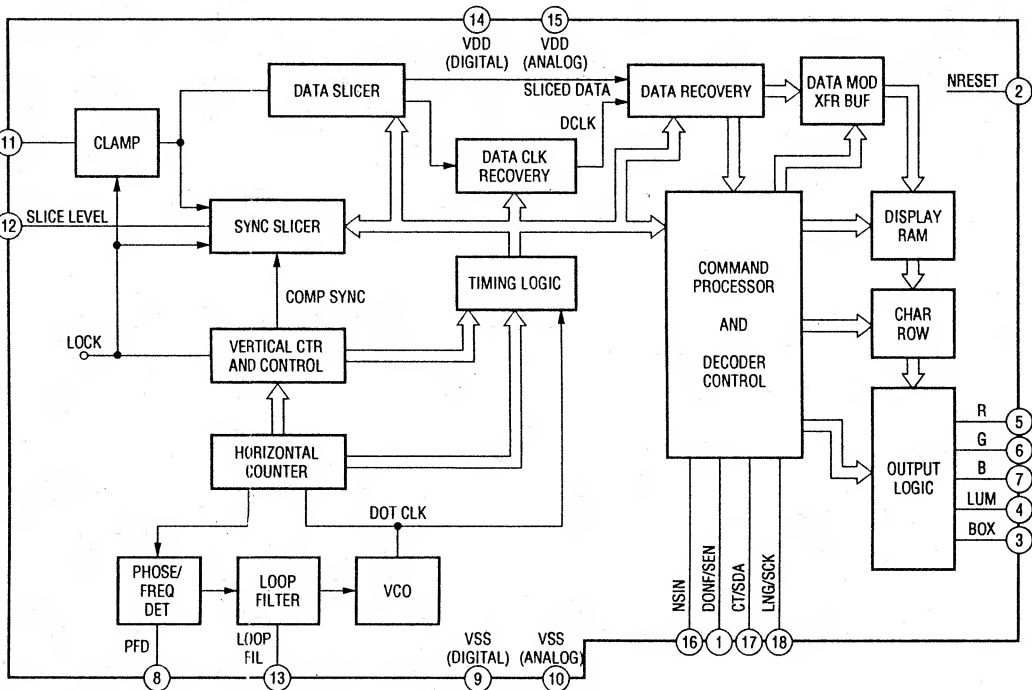

G BOARD IC602 STR-S3115

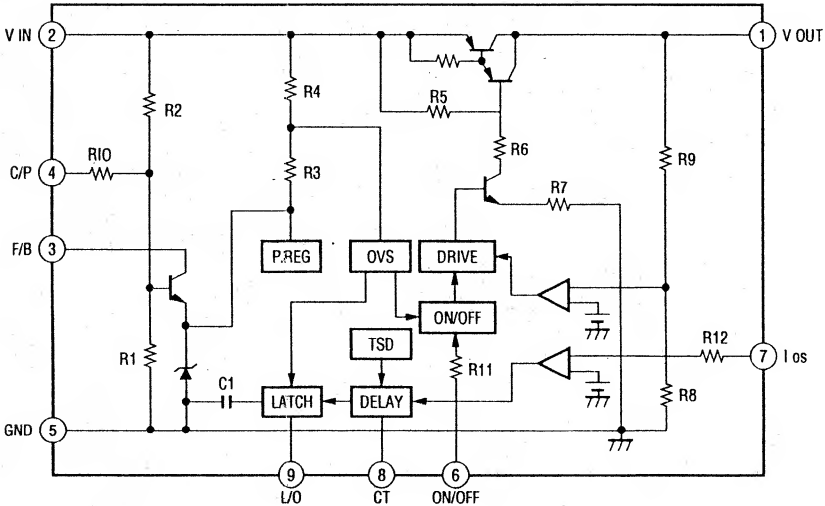

G [POWER SUPPLY]

GA [+8V REG]

J [POWER SWITCH]

X [INDICATOR]

M [S]

- G BOARD -

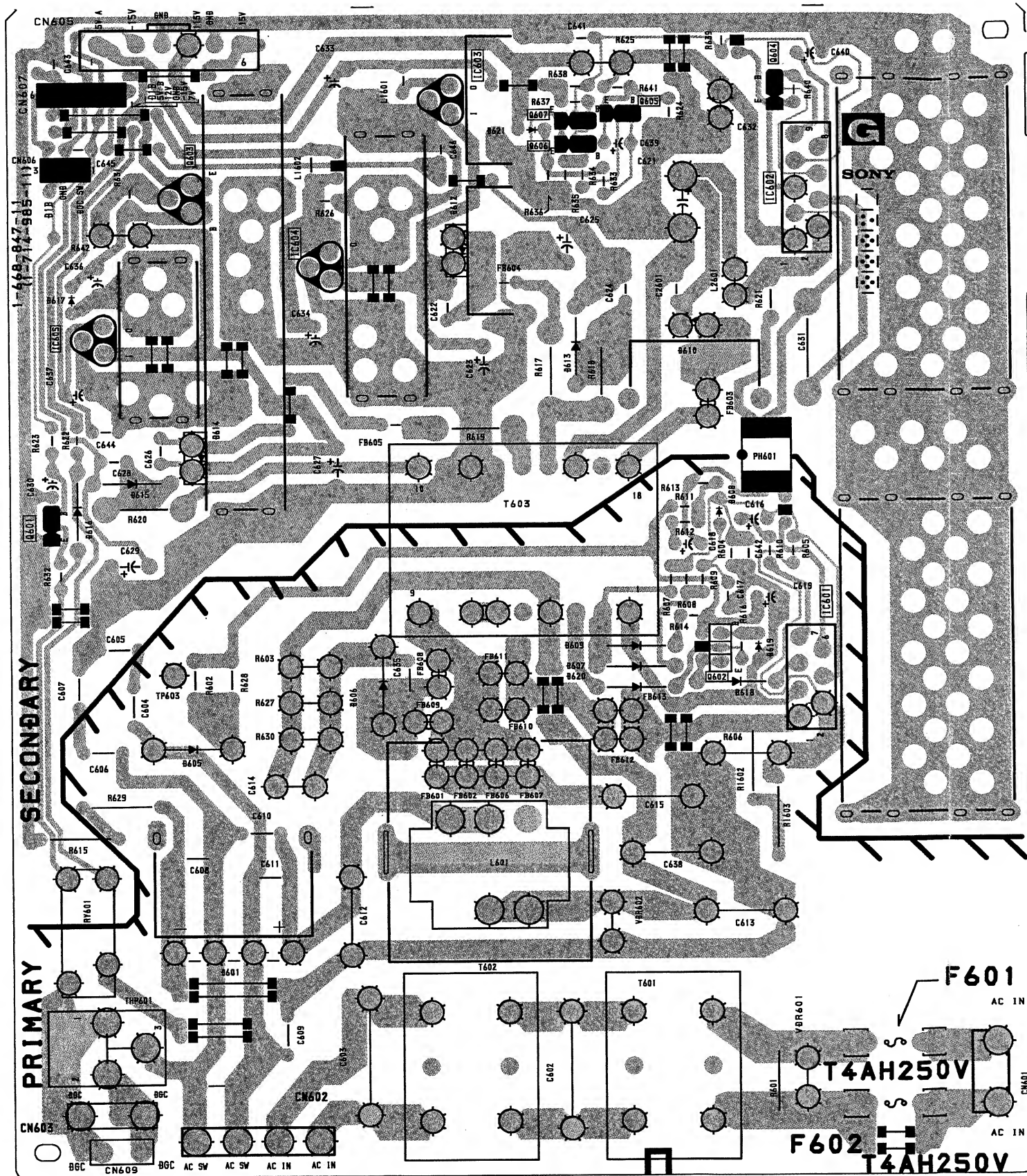

- GA BOARD -

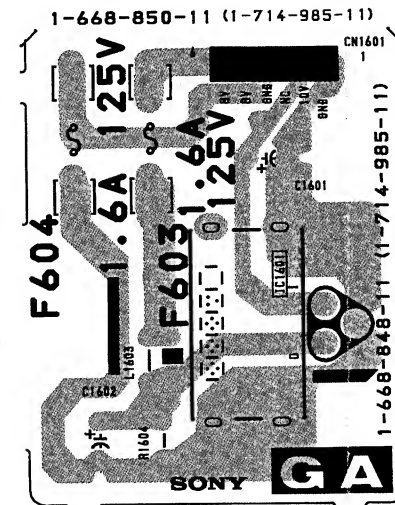

- M BO



- Q BOARD -

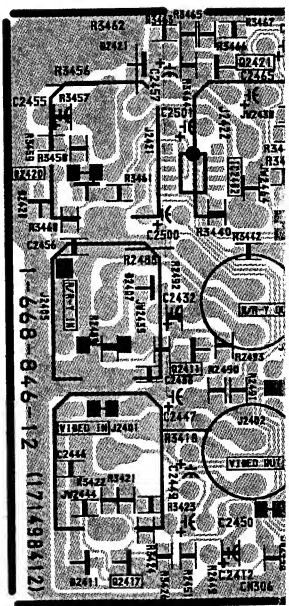

- J BOARD -

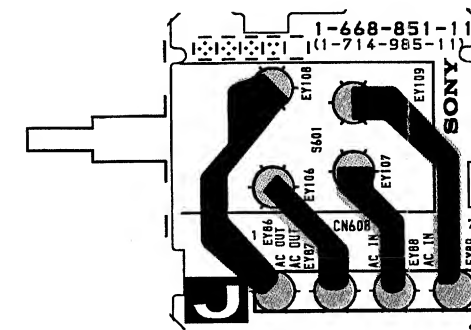

- X BOARD -

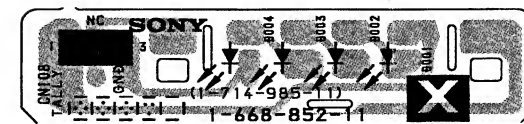

GA

[+8V REG]

J

[POWER SWITCH]

X

[INDICATOR]

M

[SERIAL REMOTE]

Q

[SIGNAL IN/OUT, AUDIO IN/OUT]

S

[CAPTION DECODER]

- GA BOARD -

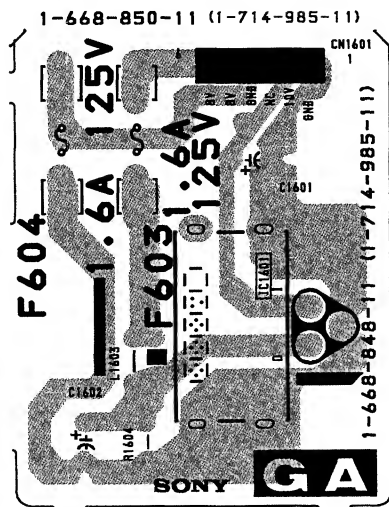

- M BOARD - <A Side>

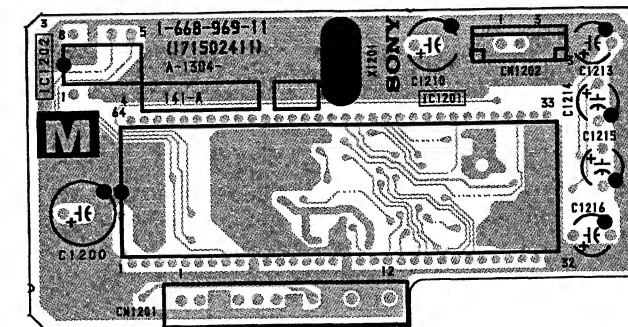

<B Side>

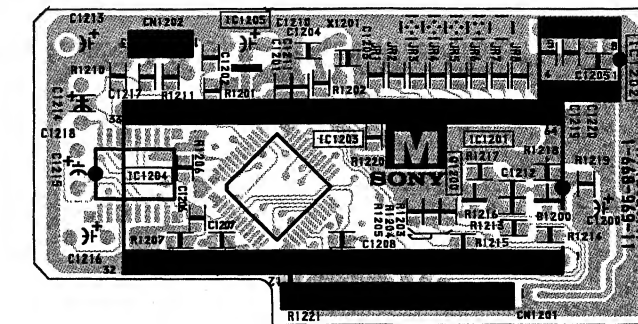

- Q BOARD -

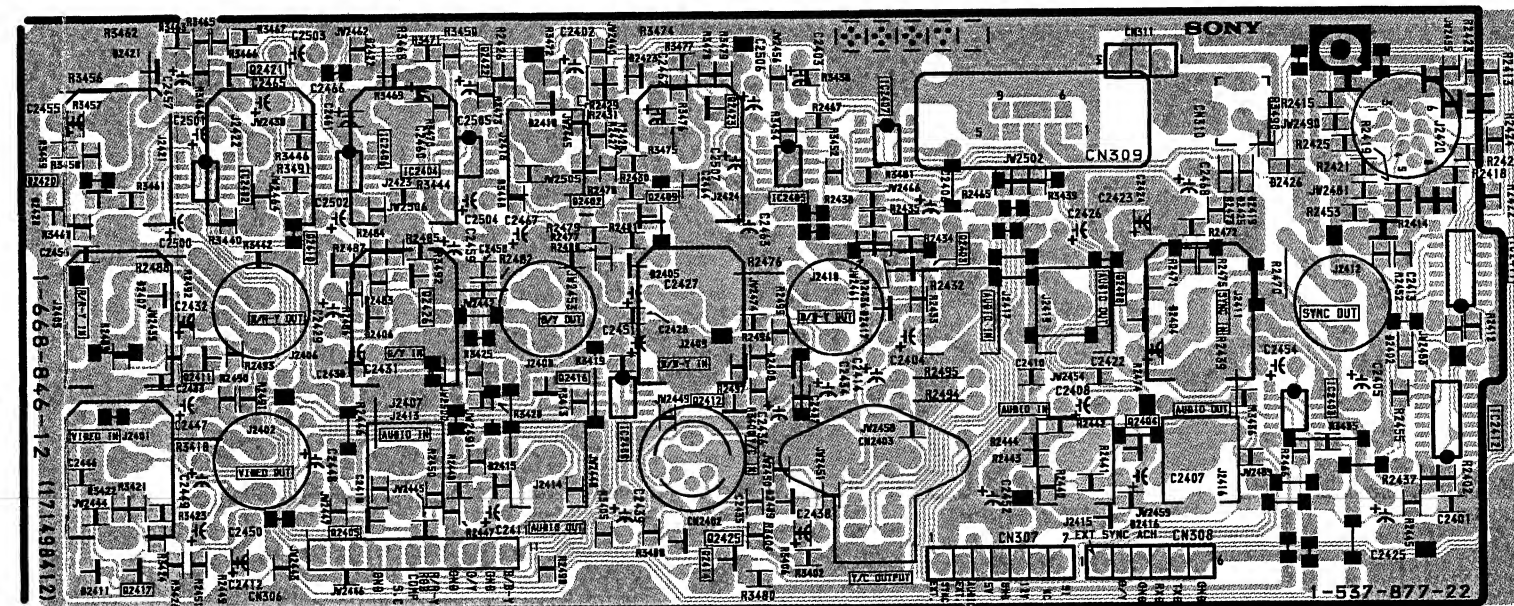

- J BOARD -

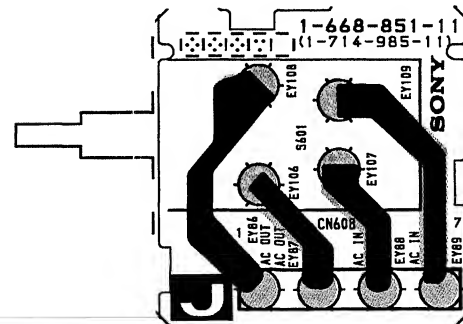

- X BOARD -

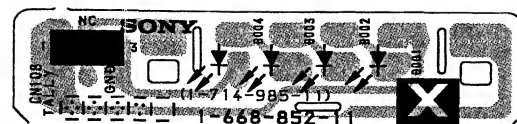

- S BOARD -

U/C MODEL ONLY

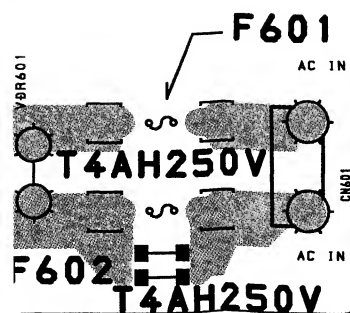
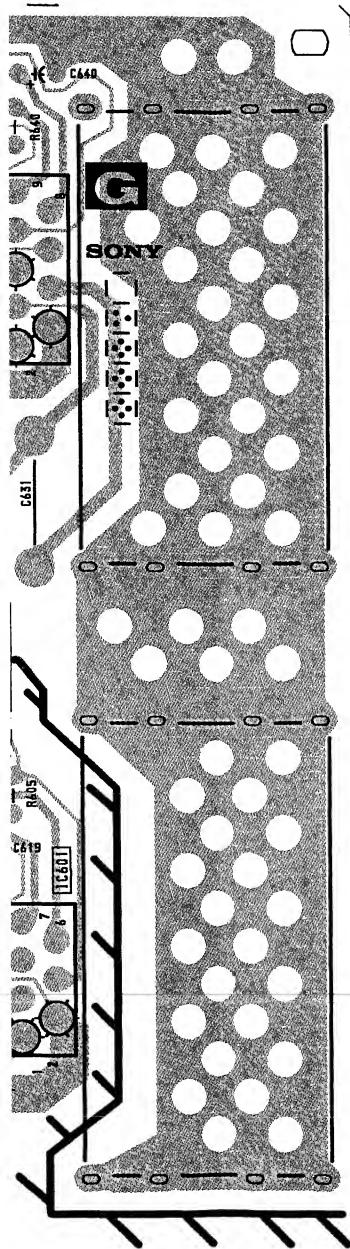
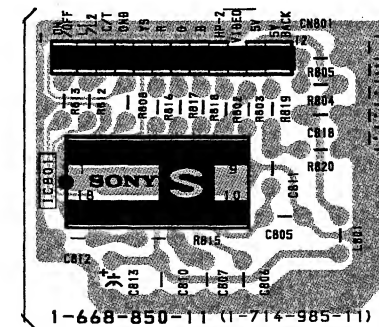

Schematic diagram

C board (14inch) →

1 2 3 4 5 6 7 8 9 10

A
B
C
D
E
F
G
H

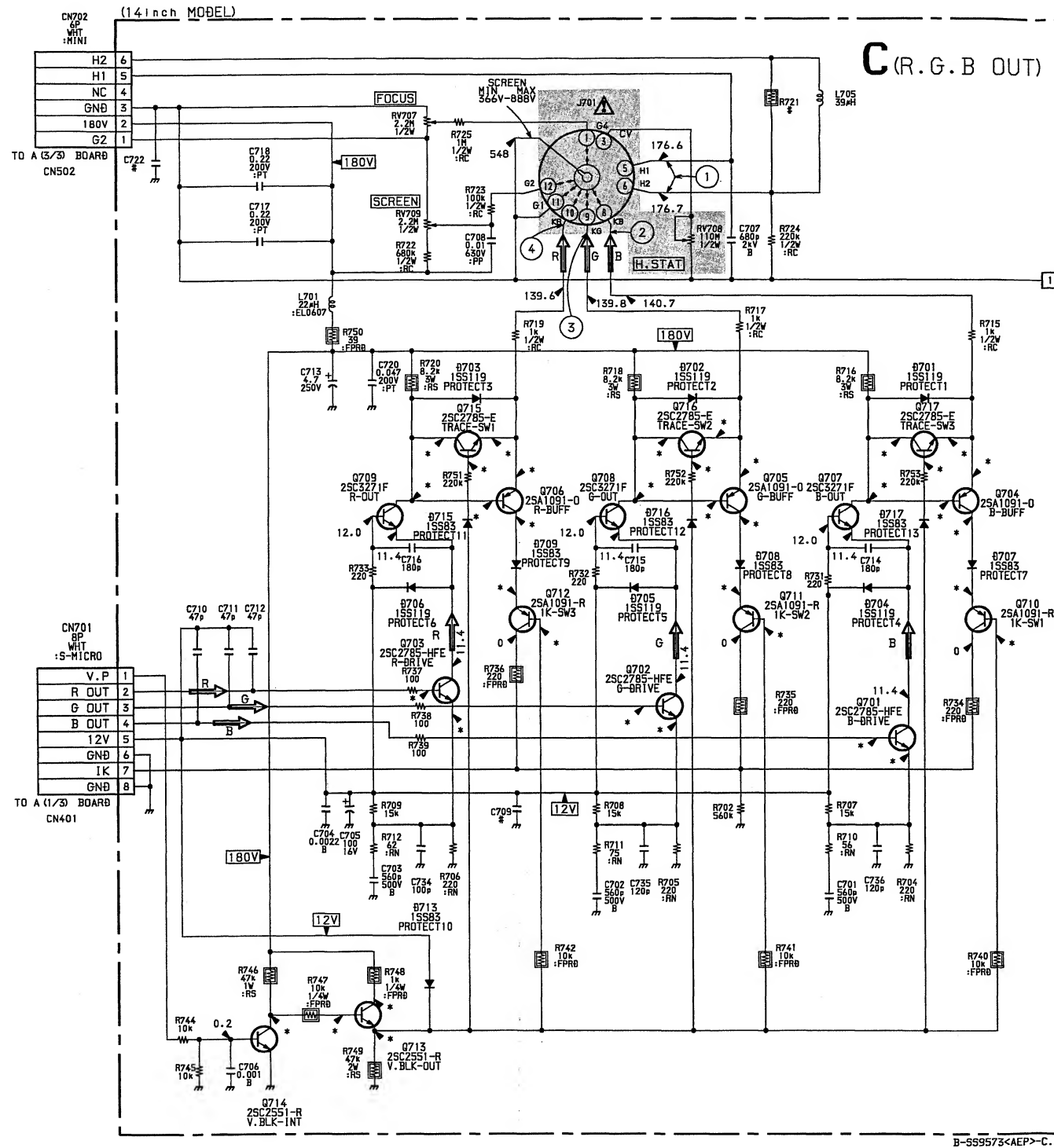

C BOARD * MARK VOLTAGE (14inch)

	PAL	NTSC 3.58	NTSC 4.43	S-VIDEO	ANALOG RGB
Q701 B	2.0	1.73	1.8	1.8	2.0
E	1.4	1.1	1.1	1.2	1.4
Q702 B	2.0	1.7	1.7	1.8	2.0
E	1.5	1.1	1.1	1.2	1.4
Q703 B	1.9	1.6	1.6	1.8	1.9
E	1.3	1.0	1.0	1.2	1.3
Q704 B	143.6	153.9	153.4	144.9	143.8
C	129.0	135.4	134.5	31.2	111.5
E	139.7	150.3	149.6	140.4	140.1
Q705 B	141.7	154.9	154.2	145.0	141.8
C	124.9	132.3	130.4	60.4	106.6
E	138.3	151.3	150.6	140.7	138.5
Q706 B	149.7	160.4	159.8	144.9	148.6
C	134.5	141.2	141.1	103.2	114.7
E	146.2	157.1	156.4	140.8	145.0
Q707 C	143.8	154.0	153.4	144.9	143.7
Q708 C	141.9	155.2	154.3	145.0	141.8
Q709 C	149.8	160.6	159.9	144.9	148.5
Q710 B	172.8	174.3	173.9	167.0	173.5
E	160.9	162.9	162.2	154.0	161.2
Q711 B	172.8	174.3	173.9	167.0	173.5
E	160.6	162.3	161.8	154.1	161.3
Q712 B	172.9	174.0	174.2	167.0	173.5
E	161.6	164.1	164.8	154.5	161.4
Q713 B	172.8	173.9	173.9	166.8	173.5
C	184.2	184.7	184.6	176.6	183.8
E	173.3	174.3	174.3	167.2	173.9
Q714 C	173.6	174.5	174.4	167.4	174.1
Q715 B	146.7	157.6	157.0	140.3	145.7
C	149.5	160.6	159.9	144.9	148.5
E	146.1	157.2	156.5	140.7	145.0
Q716 B	139.2	152.5	151.5	140.7	139.4
C	141.7	155.2	154.2	145.1	141.8
E	138.2	151.4	150.5	140.6	138.4
Q717 B	140.9	151.7	150.8	140.6	141.2
C	143.6	154.1	153.4	144.9	143.8
E	139.8	150.5	149.6	140.4	140.0

C BOARD WAVEFORMS (14inch)

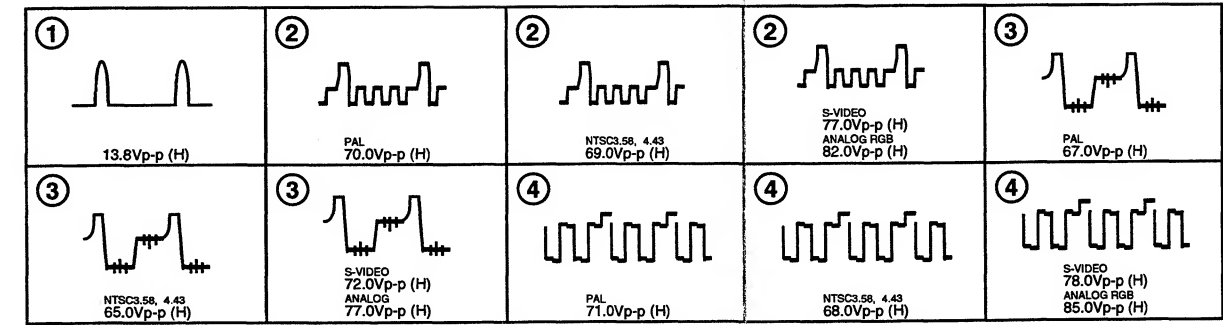

8 9 10

C (R.G.B OUT)

- C BOARD -

C BOARD * MARK VOLTAGE (14inch)

		PAL	NTSC 3.58	NTSC 4.43	S-VIDEO	ANALOG RGB
Q701	B	2.0	1.73	1.8	1.8	2.0
	E	1.4	1.1	1.1	1.2	1.4
Q702	B	2.0	1.7	1.7	1.8	2.0
	E	1.5	1.1	1.1	1.2	1.4
Q703	B	1.9	1.6	1.6	1.8	1.9
	E	1.3	1.0	1.0	1.2	1.3
Q704	B	143.6	153.9	153.4	144.9	143.8
	C	129.0	135.4	134.5	31.2	111.5
	E	139.7	150.3	149.6	140.4	140.1
Q705	B	141.7	154.9	154.2	145.0	141.8
	C	124.9	132.3	130.4	60.4	106.6
	E	138.3	151.3	150.6	140.7	138.5
Q706	B	149.7	160.4	159.8	144.9	148.6
	C	134.5	141.2	141.1	103.2	114.7
	E	146.2	157.1	156.4	140.8	145.0
Q707	C	143.8	154.0	153.4	144.9	143.7
Q708	C	141.9	155.2	154.3	145.0	141.8
Q709	C	149.8	160.6	159.9	144.9	148.5
Q710	B	172.8	174.3	173.9	167.0	173.5
	E	160.9	162.9	162.2	154.0	161.2
Q711	B	172.8	174.3	173.9	167.0	173.5
	E	160.6	162.3	161.8	154.1	161.3
Q712	B	172.9	174.0	174.2	167.0	173.5
	E	161.6	164.1	164.8	154.5	161.4
Q713	B	172.8	173.9	173.9	166.8	173.5
	C	184.2	184.7	184.6	176.6	183.8
	E	173.3	174.3	174.3	167.2	173.9
Q714	C	173.6	174.5	174.4	167.4	174.1
Q715	B	146.7	157.6	157.0	140.3	145.7
	C	149.5	160.6	159.9	144.9	148.5
	E	146.1	157.2	156.5	140.7	145.0
Q716	B	139.2	152.5	151.5	140.7	139.4
	C	141.7	155.2	154.2	145.1	141.8
	E	138.2	151.4	150.5	140.6	138.4
Q717	B	140.9	151.7	150.8	140.6	141.2
	C	143.6	154.1	153.4	144.9	143.8
	E	139.8	150.5	149.6	140.4	140.0

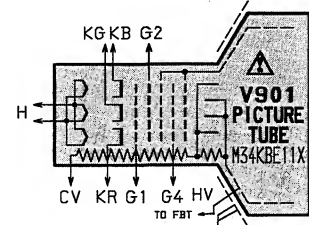
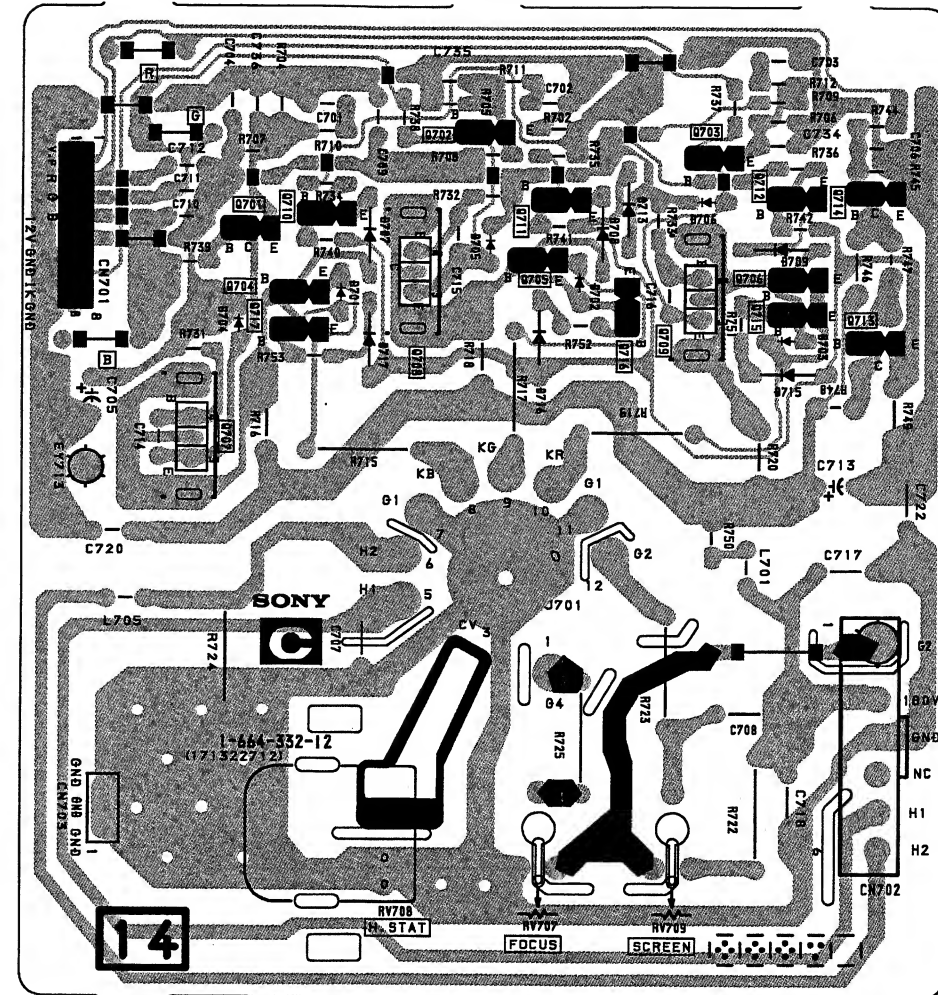

C BOARD WAVEFORMS (14inch)

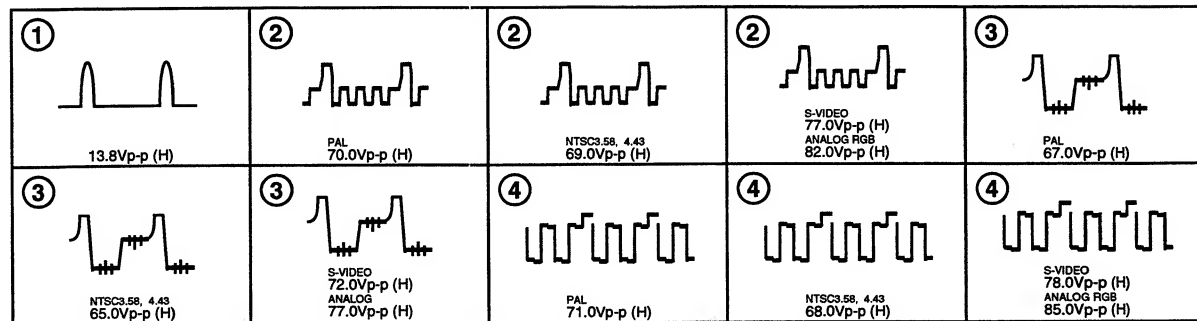

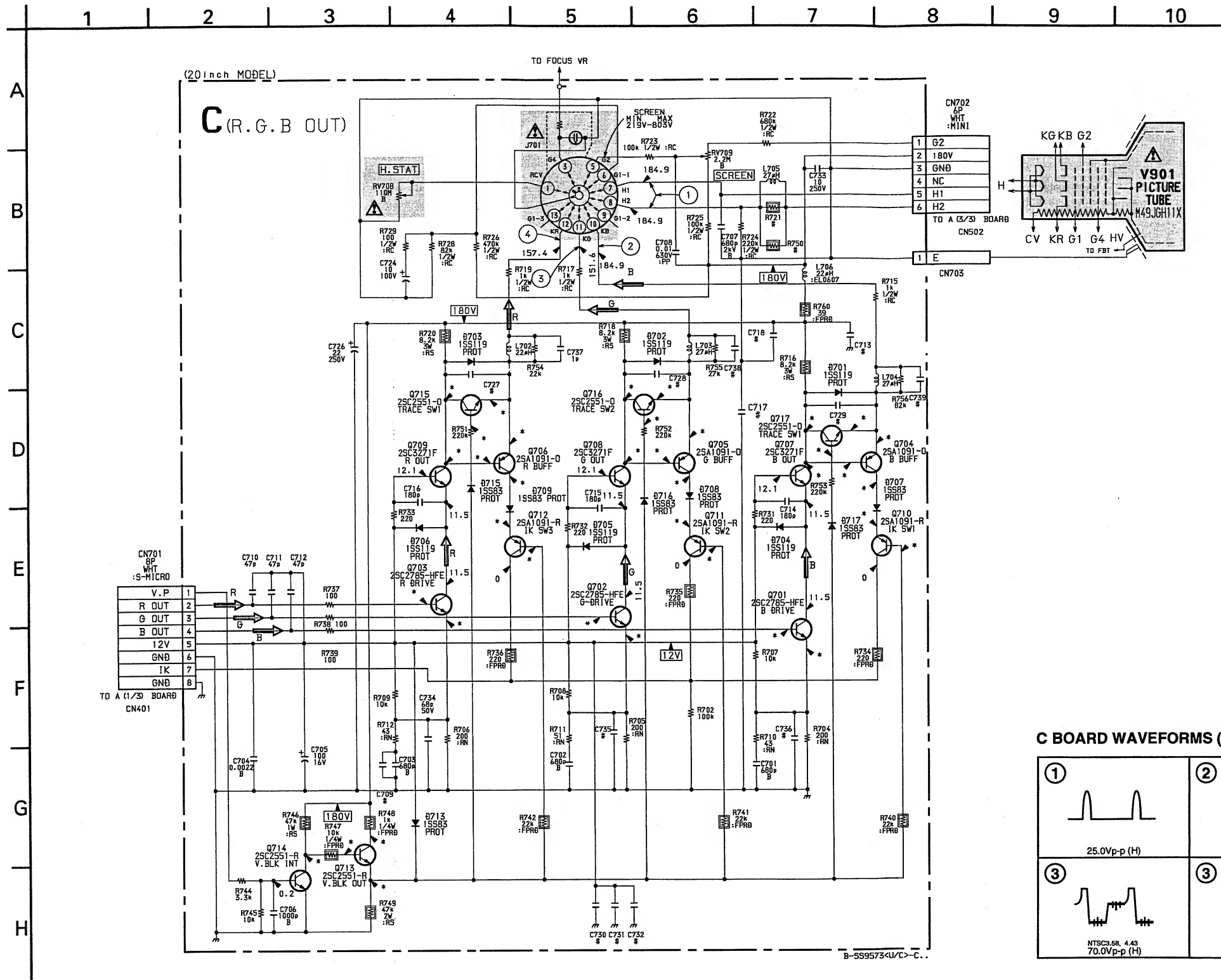

C BOARD * MARK VOLTAGE (20inch)

	PAL	NTSC	NTSC	S-VIDEO	ANALOG
Q701 B	2.0	3.58	4.43	1.8	2.0
E	1.4	1.1	1.1	1.2	1.4
Q702 B	2.0	1.7	1.7	1.8	2.0
E	1.5	1.1	1.1	1.2	1.4
Q703 B	1.9	1.6	1.6	1.8	1.9
E	1.3	1.0	1.0	1.2	1.3
Q704 B	143.6	153.9	153.4	144.9	143.8
E	129.0	135.4	134.5	31.2	111.5
Q705 B	139.7	150.3	149.6	140.4	140.1
E	141.7	154.9	154.2	145.0	141.8
C	124.9	132.3	130.4	60.4	106.6
Q706 B	138.3	151.3	150.6	140.7	138.5
E	149.7	160.4	159.8	144.9	148.6
C	134.5	141.2	141.1	103.2	114.7
E	146.2	157.1	156.4	140.8	145.0
Q707 C	143.8	154.0	153.4	144.9	143.7
Q708 C	141.9	155.2	154.3	145.0	141.8
Q709 C	149.8	160.6	159.9	144.9	148.5
Q710 B	172.8	174.3	173.9	167.0	173.5
E	160.9	162.9	162.2	154.0	161.2
Q711 B	172.8	174.3	173.9	167.0	173.5
E	160.6	162.3	161.8	154.1	161.3
Q712 B	172.9	174.0	174.2	167.0	173.5
E	161.6	164.1	164.8	154.5	161.4
Q713 B	172.8	173.9	173.9	166.8	173.5
C	184.2	184.7	184.6	176.6	183.8
E	173.3	174.3	174.3	167.2	173.9
Q714 C	173.6	174.5	174.4	167.4	174.1
Q715 B	146.7	157.6	157.0	140.3	145.7
C	149.5	160.6	159.9	144.9	148.5
E	146.1	157.2	156.5	140.7	145.0
Q716 B	139.2	152.5	151.5	140.7	139.4
C	141.7	155.2	154.2	145.1	141.8
E	138.2	151.4	150.5	140.6	138.4
Q717 B	140.9	151.7	150.8	140.6	141.2
C	143.6	154.1	153.4	144.9	143.8
E	139.8	150.5	149.6	140.4	140.0

C BOARD WAVEFORMS (20inch)

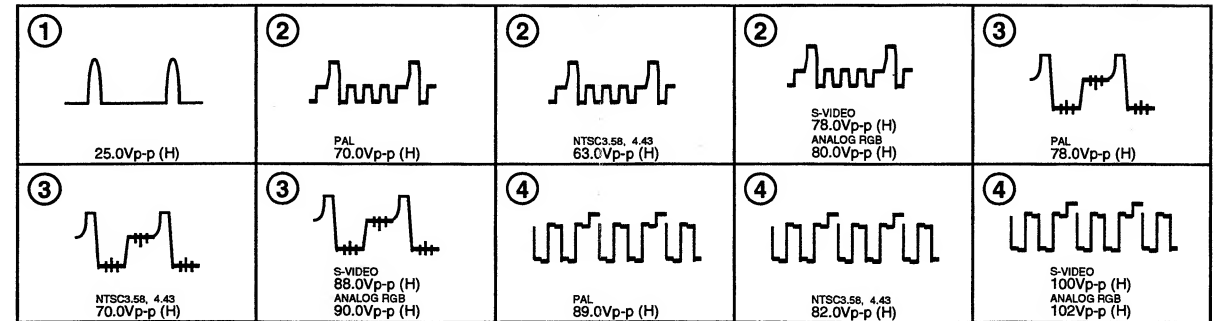

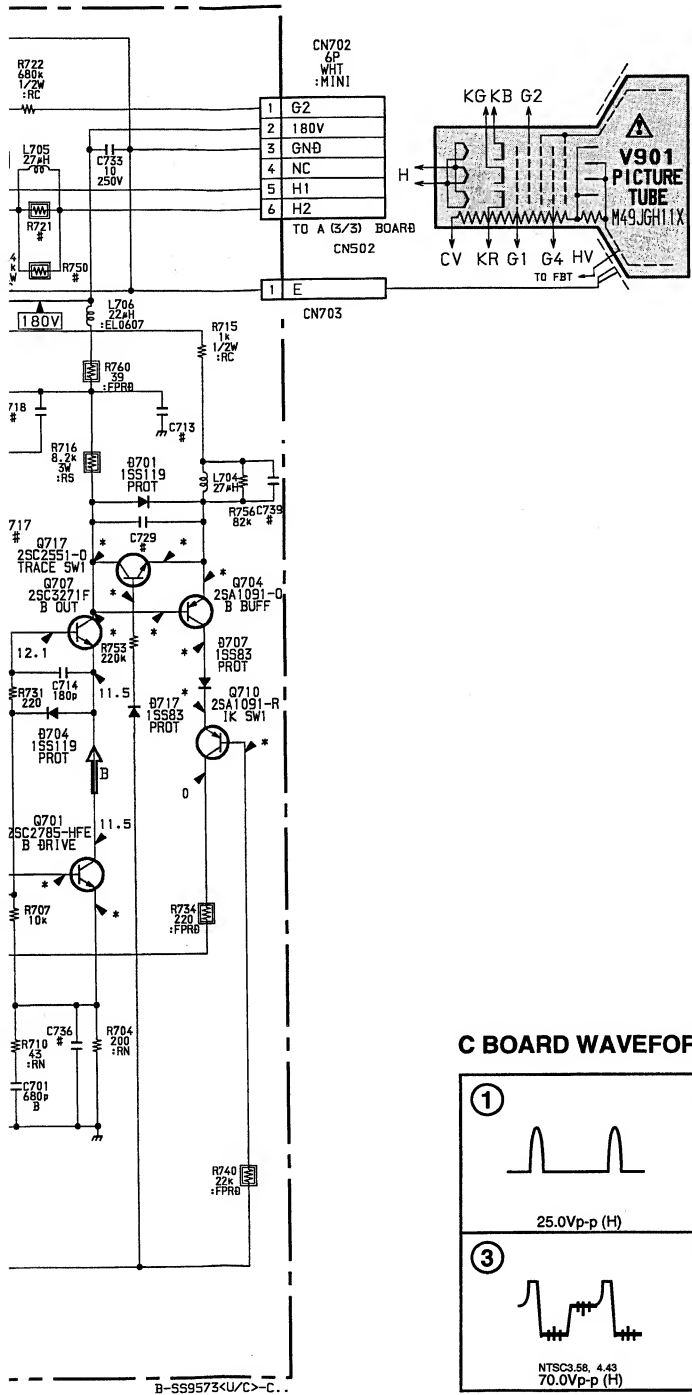

C BOARD * MARK VOLTAGE (20inch)

		PAL	NTSC 3.58	NTSC 4.43	S-VIDEO	ANALOG RGB
Q701	B	2.0	1.73	1.8	1.8	2.0
	E	1.4	1.1	1.1	1.2	1.4
Q702	B	2.0	1.7	1.7	1.8	2.0
	E	1.5	1.1	1.1	1.2	1.4
Q703	B	1.9	1.6	1.6	1.8	1.9
	E	1.3	1.0	1.0	1.2	1.3
Q704	B	143.6	153.9	153.4	144.9	143.8
	C	129.0	135.4	134.5	31.2	111.5
	E	139.7	150.3	149.6	140.4	140.1
Q705	B	141.7	154.9	154.2	145.0	141.8
	C	124.9	132.3	130.4	60.4	106.6
	E	138.3	151.3	150.6	140.7	138.5
Q706	B	149.7	160.4	159.8	144.9	148.6
	C	134.5	141.2	141.1	103.2	114.7
	E	146.2	157.1	156.4	140.8	145.0
Q707	C	143.8	154.0	153.4	144.9	143.7
Q708	C	141.9	155.2	154.3	145.0	141.8
Q709	C	149.8	160.6	159.9	144.9	148.5
Q710	B	172.8	174.3	173.9	167.0	173.5
	E	160.9	162.9	162.2	154.0	161.2
Q711	B	172.8	174.3	173.9	167.0	173.5
	E	160.6	162.3	161.8	154.1	161.3
Q712	B	172.9	174.0	174.2	167.0	173.5
	E	161.6	164.1	164.8	154.5	161.4
Q713	B	172.8	173.9	173.9	166.8	173.5
	C	184.2	184.7	184.6	176.6	183.8
	E	173.3	174.3	174.3	167.2	173.9
Q714	C	173.6	174.5	174.4	167.4	174.1
Q715	B	146.7	157.6	157.0	140.3	145.7
	C	149.5	160.6	159.9	144.9	148.5
	E	146.1	157.2	156.5	140.7	145.0
Q716	B	139.2	152.5	151.5	140.7	139.4
	C	141.7	155.2	154.2	145.1	141.8
	E	138.2	151.4	150.5	140.6	138.4
Q717	B	140.9	151.7	150.8	140.6	141.2
	C	143.6	154.1	153.4	144.9	143.8
	E	139.8	150.5	149.6	140.4	140.0

C BOARD WAVEFORMS (20inch)

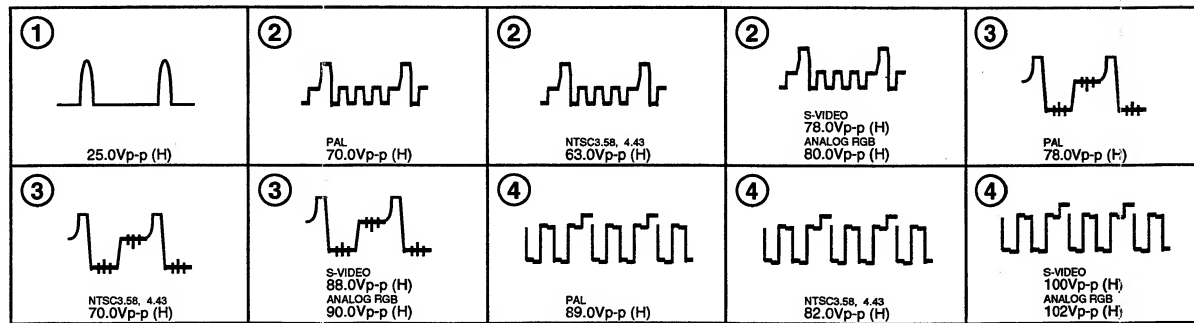

C [R.G.B OUT]

- C BOARD -

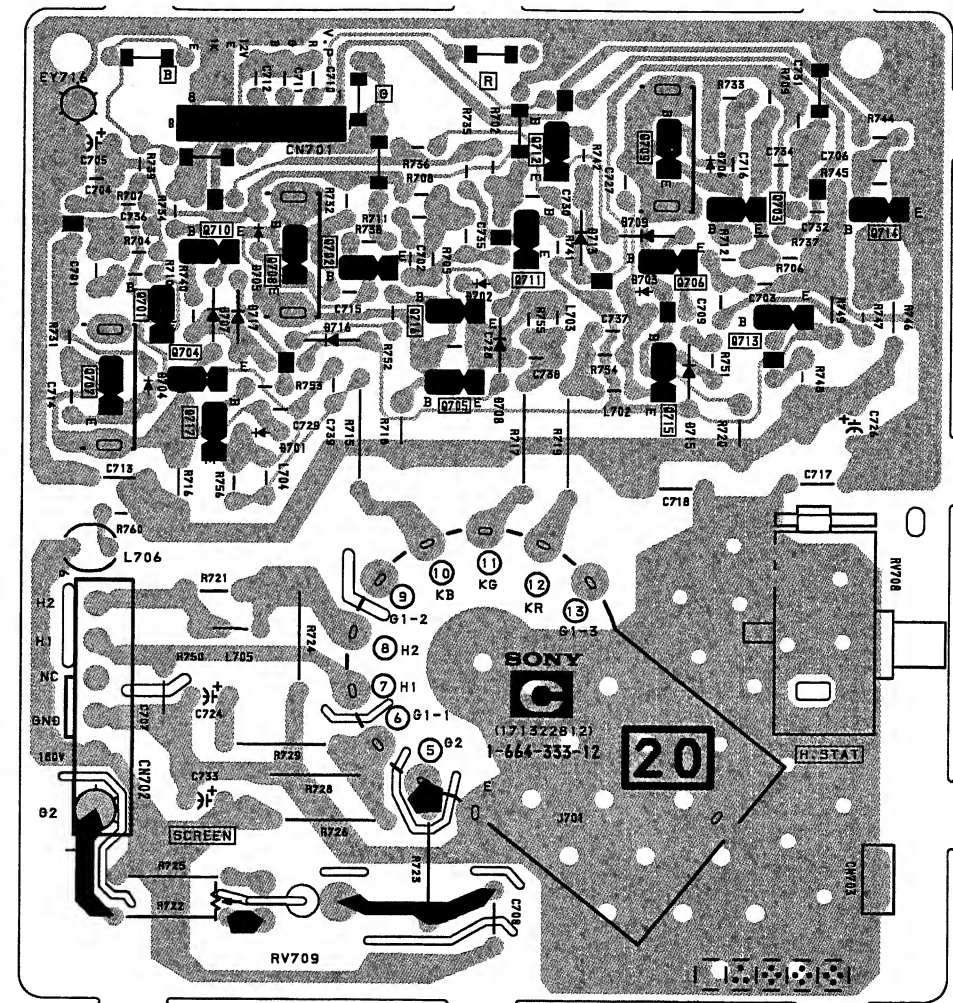

Schematic diagram

← C board (20inch)

6-5. SEMICONDUCTORS

ADM232LAR-REEL
XRU4021BF
XRU4053BCF

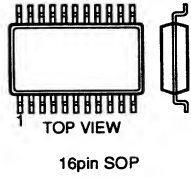

H8D7249

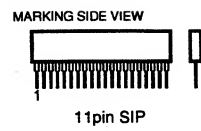

MC14052BF
MC14538BF

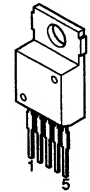

MC14094BF

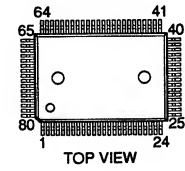

M51279FP



M62358FP-E1

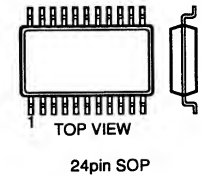

NJM78M05FA
μPC2408AHF

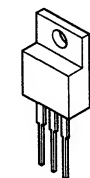

S-80743AL-A7-S

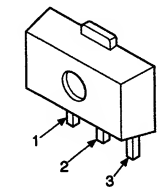

CXA1739S

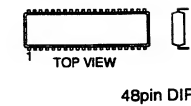

STR-M6524

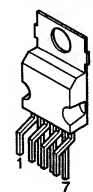

STR-S3115

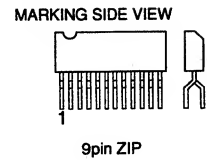

μPC1377C



μPD6451AGT-632-E2

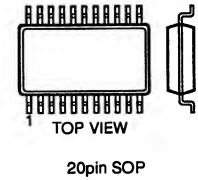

μPD71051GB-10

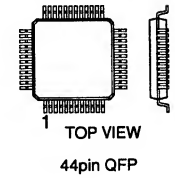

μPD78P018FYCW

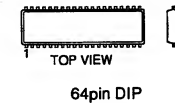

XRA17812T

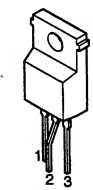

Z8622812PSC

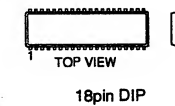

DTA144EKA-T146
DTC124EKA-T146
DTC144EKA-T146
2SA1037K-T-146-Q
2SA1162-G
2SB709A-R
2SC1623-L5L6
2SC2412K-T-146-QR
2SC2412K-T-146-S
2SD601A-S

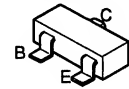

DTC114ESA
2SC2785-HFE

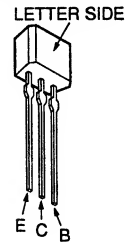

IMT1US

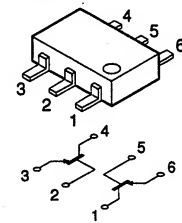

IMX1

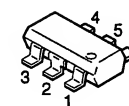

2SA1091-0
2SC2551-0

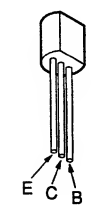

2SA1220A
2SC2611
2SC688-LK
2SC2690A-Q
2SC3271F-N
2SD1640Q
2SD1640Q, R

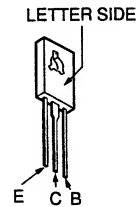

2SC2958
2SD774-34

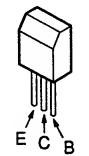

2SC3851-G
2SD2396K

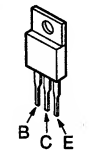

2SD1210 (LK)

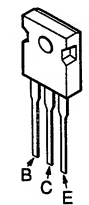

2SD1878-CA

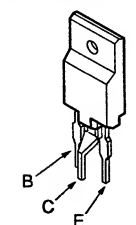

2SK94
2SK94-X2X3X4

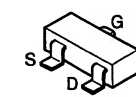

DTZ-TT11-11B
DTZ-TT11-13C
DTZ-TT11-5.6B
DTZ-TT11-6.2
DTZ11B
DTZ13C
DTZ5.6B
DTZ6.2
MA111

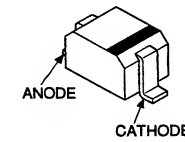

D4SB60L

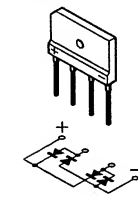

D5L60
FMB-G16L
FML-G12S

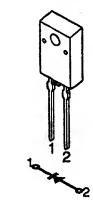

EGP20G
EL1Z
ERD07-15
RGP02-17EL-6433
RGP10GPKG23
RGP15J-6040
RGP15K-6179
UF5406
10E2
1SS83

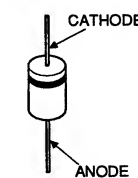

ERA15-06
RD16ES-B2
RD16ES-B3
RD20ES-B2
1SS119-25
1SS133T-77

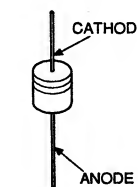

ERC38-06
V19E
V19G

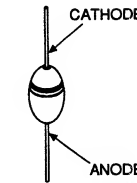

MA151WK
1SS184

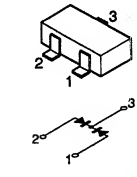

PC111YS

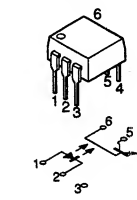

RD10SB1

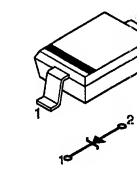

RH-1A
RH-1Z

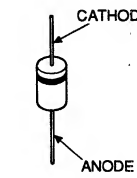

1SS226

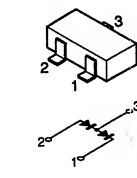

1SV230TPH3
1SV232-TPH3

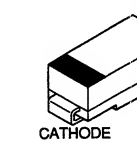

1S2835
1S2836

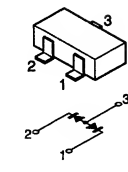

SEL4410E-D
SLP281C-50
TLG123A
TLY123

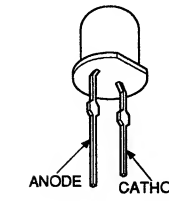

ANODE
CATHODE

2SA1220A
2SC2611
2SC688-LK
2SC2690A-Q
2SC3271F-N
2SD1640Q
2SD1640Q, R

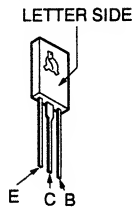

2SC2958
2SD774-34

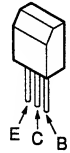

2SC3851-G
2SD2396K

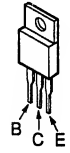

2SD1210 (LK)



2SD1878-CA

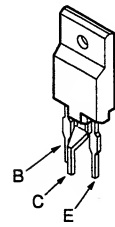

2SK94
2SK94-X2X3X4

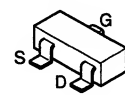

DTZ-TT11-11B
DTZ-TT11-13C
DTZ-TT11-5.6B
DTZ-TT11-6.2
DTZ11B
DTZ13C
DTZ5.6B
DTZ6.2
MA111

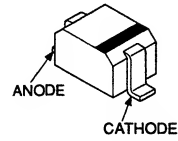

D4SB60L

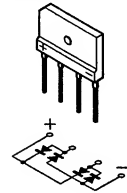

D5L60
FMB-G16L
FML-G12S

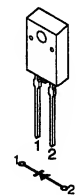

EGP20G
EL1Z
ERD07-15
RGP02-17EL-6433
RGP10GPKG23
RGP15J-6040
RGP15K-6179
UF5406
10E2
1SS83

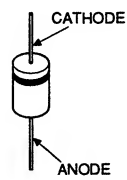

ERA15-06
RD16ES-B2
RD16ES-B3
RD20ES-B2
1SS119-25
1SS133T-77

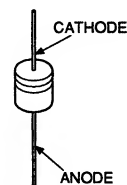

ERC38-06
V19E
V19G

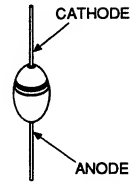

MA151WK
1SS184

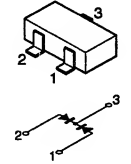

PC111YS

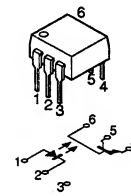

RD10SB1

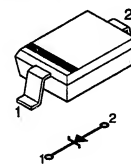

RH-1A
RH-1Z

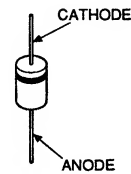

1SS226

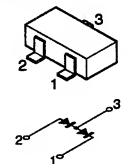

1SV230TPH3
1SV232-TPH3

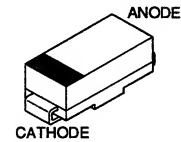

1S2835
1S2836

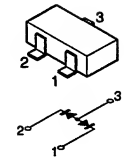

SEL4410E-D
SLP281C-50
TLG123A
TLY123

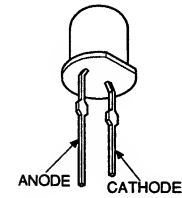

SECTION 7 EXPLODED VIEWS

The components identified by shading and mark Δ are critical for safety. Replace only with part number specified.

Les composants identifiés par une trame et une marque Δ sont critiques pour la sécurité. Ne les remplacer que par une pièce portant le numéro spécifié.

NOTE:

• Items with no part number and no description are not stocked because they are seldom required for routine service.

• The construction parts of an assembled part are indicated with a collation number in the remark column.

• Items marked " * " are not stocked since they are seldom required for routine service. Some delay should be anticipated when ordering these items.

7-1. CHASSIS [14M2MDU/E/A]

- : 7-685-648-79 +BVTP 3X12
- : 7-682-661-01 +PS 4X8
- ▲ : 7-685-646-79 +BVTP 3X8
- ◆ : 7-685-663-79 +BVTP 4X16
- ▼ : 7-685-881-09 +BVTT 4X8

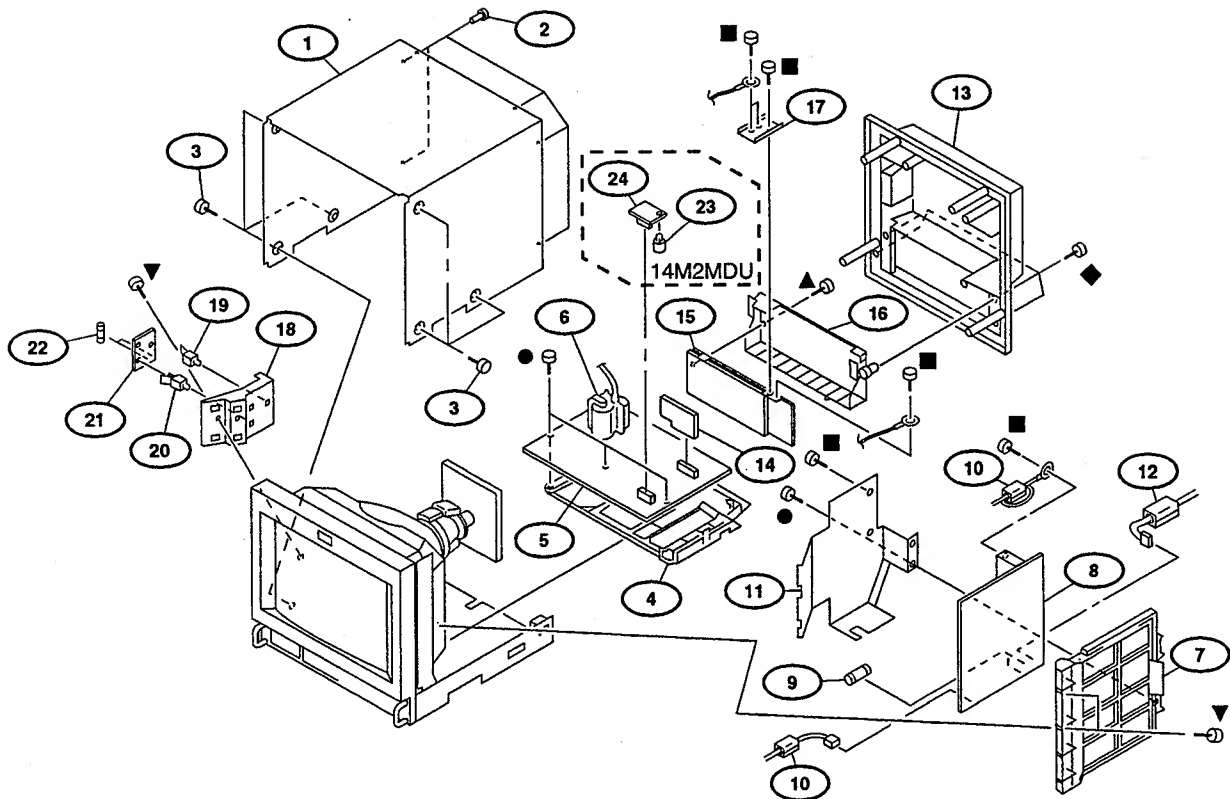

REF. NO.	PART NO.	DESCRIPTION	REMARK	REF. NO.	PART NO.	DESCRIPTION	REMARK
1	X-4035-200-2	COVER ASSY, TOP		13	4-055-635-01	COVER, REAR	
2	4-391-825-01	RIVET, NYLON		14	*A-1304-141-A	M BOARD, COMPLETE	
3	4-847-802-11	SCREW (OS), CASE, CLAW		15	1-537-877-21	TERMINAL BOARD ASSY, I/O	
4	*4-043-690-01	BRACKET, MAIN		16	4-043-688-81	PANEL, CONNECTOR	
5	*A-1298-296-A	A BOARD, COMPLETE		17	*4-058-363-01	TERMINAL, EARTH	
6	Δ 1-453-233-11	TRANSFORMER ASSY, FLYBACK		18	*4-391-842-06	BRACKET, HVR	
7	*4-043-689-01	BRACKET, G		19	*4-321-929-00	HOLDER, PC BOARD	
8	*A-1316-349-A	G BOARD, COMPLETE		20	*3-703-141-00	HOLDER, PWB	
9	Δ 1-576-231-11	FUSE (H.B.C.) 4A/250V		21	*A-1316-350-A	GA BOARD, COMPLETE	
10	1-543-827-11	CLAMP, SLEEVE FERRITE		22	Δ 1-532-742-11	FUSE, GLASS TUBE 1.6A/125V	
11	*4-062-488-01	SHIELD, G PWB		23	*3-687-542-41	SPACER, PC BOARD SPACE (14M2MDU)	
12	1-543-653-11	CORE ASSY, BEAD(DIVISION TYPE)		24	*A-1390-779-A	S BOARD, COMPLETE (14M2MDU)	

7-2. PICTURE TUBE [14M2MDU/E/A]

- : 7-685-648-79 +BVTP 3X12
- : 7-682-648-09 +PS 3X8
- : 7-682-563-09 +B 4X12

The components identified by shading and mark Δ are critical for safety. Replace only with part number specified.

Les composants identifiés par une trame et une marque Δ sont critiques pour la sécurité. Ne les remplacer que par une pièce portant le numéro spécifié.

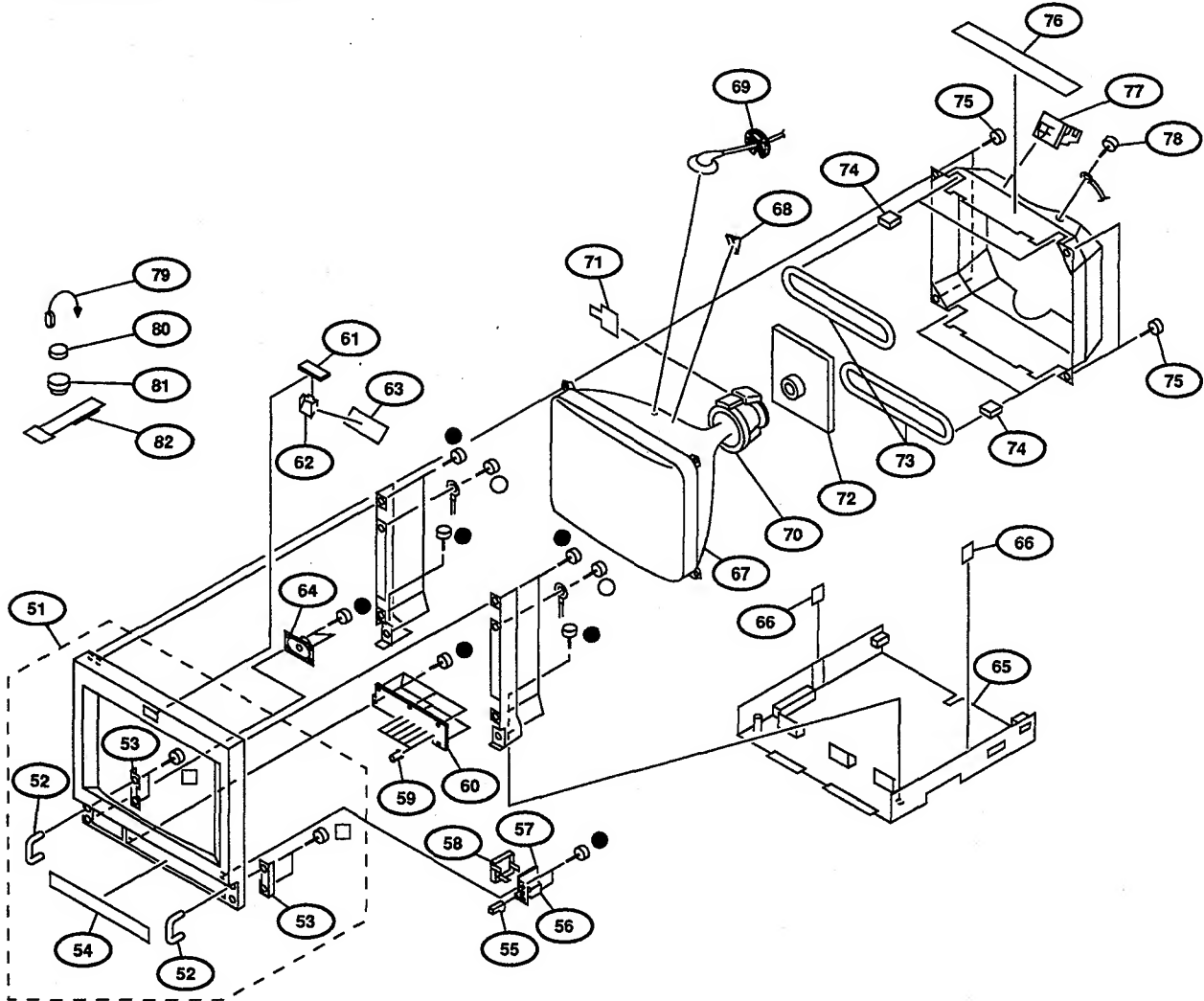

REF. NO.	PART NO.	DESCRIPTION	REMARK	REF. NO.	PART NO.	DESCRIPTION	REMARK
51	X-4035-199-1	BEZEL ASSY		67	A-8-738-342-05	PICTURE TUBE 14MG(DARK) (M34KBE11X)	
52	4-052-200-11	HANDLE, PROTECTOR	52-54	68	3-703-961-01	SPACER, DY	
53	*4-043-679-01	REINFORCEMENT, HANDLE		69	3-704-372-01	HOLDER, HV CABLE	
54	*4-057-975-41	LABEL, CONTROL		70	A-8-451-472-11	DEFLECTION YOKE Y14MGAT	
55	4-043-683-01	BUTTON, POWER SWITCH		71	X-2105-533-1	PLATE ASSY, CORRECTION, TLH	
56	Δ 1-692-921-11	SWITCH, PUSH (A.C. POWER)		72	*A-1331-764-A	C BOARD, COMPLETE	
57	*A-1388-204-A	J BOARD, COMPLETE		73	Δ 1-426-442-21	COIL, DEMAGNETIZATION	
58	4-043-681-01	COVER, AC SWITCH		74	*4-316-015-00	HOLDER, WIRE	
59	4-043-802-11	KNOB, CONTROL		75	4-365-808-01	SCREW (5), TAPPING	
60	*A-1372-410-A	H BOARD, COMPLETE		76	4-391-833-01	CLOTH, PROTECTION	
61	*A-1390-778-A	X BOARD, COMPLETE		77	4-033-681-01	HOLDER, LEAD	
62	*4-043-682-01	REFLECTOR, LED		78	4-389-025-01	SCREW (M4) (EXT TOOTH WASHER)	
63	4-044-606-01	CUSHION, TALLY		79	4-308-870-00	CLIP, LEAD WIRE	
64	1-544-063-12	SPEAKER		80	1-452-032-00	MAGNET, DISK ; 10mmφ	
65	X-4031-711-1	CABINET ASSY, BOTTOM		81	1-452-094-00	MAGNET, ROTATABLE DISK ; 15mmφ	
66	4-042-608-01	NUT, PLATE		82	4-051-736-21	PIECE A(90), CONV. CORRECT	

7-3. CHASSIS [20M2MDU/E/A]

- : 7-685-648-79 +BVTP 3X12
- : 7-682-661-01 +PS 4X8
- ▲ : 7-685-646-79 +BVTP 3X8
- ◆ : 7-685-663-79 +BVTP 4X16
- ▼ : 7-685-881-09 +BVTT 4X8

The components identified by shading and mark Δ are critical for safety. Replace only with part number specified.

Les composants identifiés par une trame et une marque Δ sont critiques pour la sécurité. Ne les remplacer que par une pièce portant le numéro spécifié.

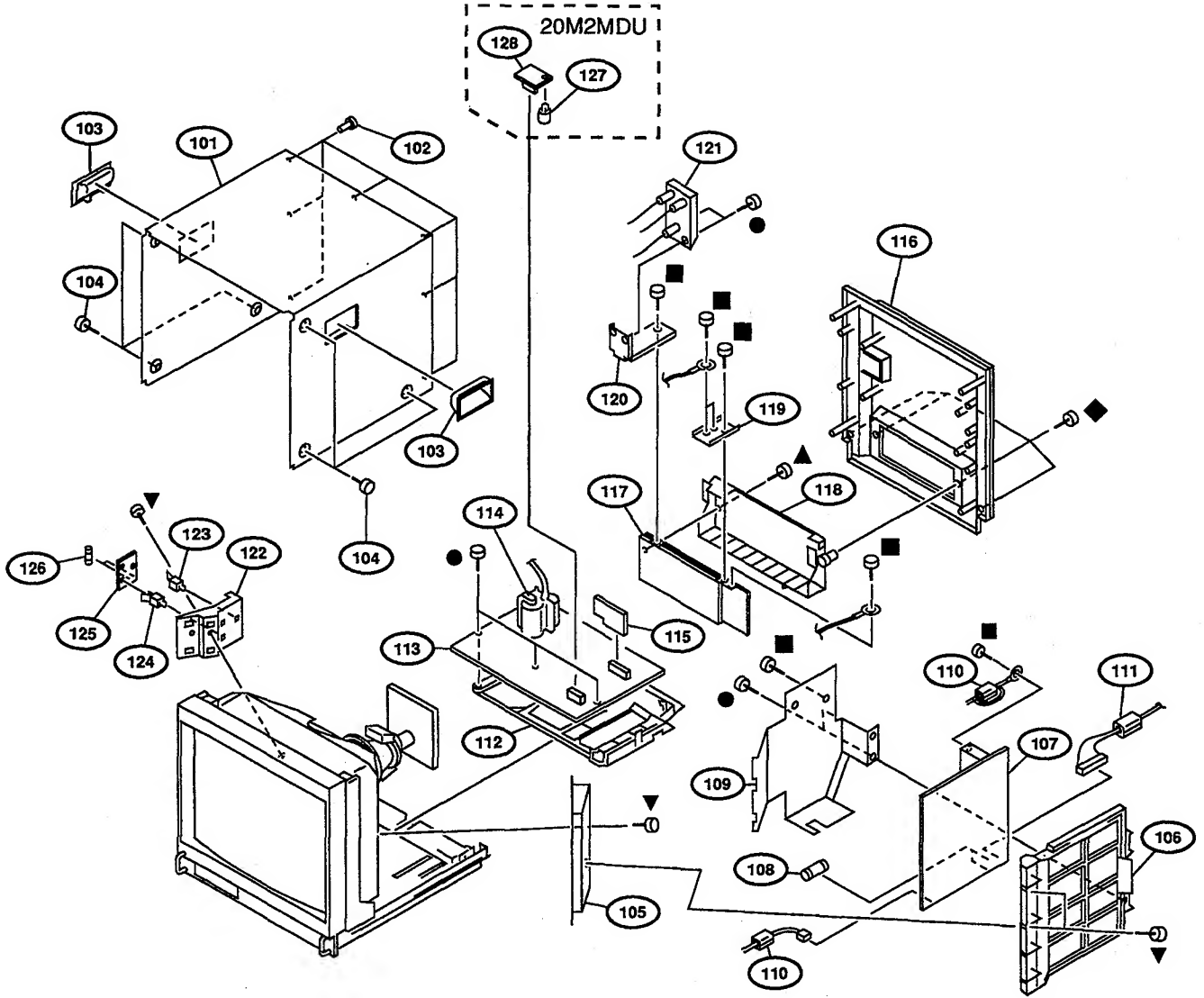

REF. NO.	PART NO.	DESCRIPTION	REMARK	REF. NO.	PART NO.	DESCRIPTION	REMARK
101	4-057-973-41	COVER, TOP		116	4-043-677-11	COVER, REAR	
102	4-391-825-01	RIVET, NYLON		117	1-537-877-21	TERMINAL BOARD ASSY, I/O	
103	4-043-825-11	HANDLE		118	4-043-688-81	PANEL, CONNECTOR	
104	4-847-802-11	SCREW (OS), CASE, CLAW		119	*4-058-363-01	TERMINAL, EARTH	
105	X-4391-825-1	HOOK ASSY, F		120	4-057-971-01	BRACKET, FOCUS VOLUME	
106	*4-043-689-01	BRACKET, G		121	Δ 1-238-368-11	RESISTOR ASSY, HIGH-VOLTAGE	
107	*A-1316-349-A	G BOARD, COMPLETE		122	*4-391-842-06	BRACKET, HVR	
108	Δ 1-576-231-11	FUSE (H.B.C.) 4A/250V		123	*4-321-929-00	HOLDER, PC BOARD	
109	*4-062-488-01	SHIELD, G PWB		124	*3-703-141-00	HOLDER, PWB	
110	1-543-827-11	CLAMP, SLEEVE FERRITE		125	*A-1316-350-A	GA BOARD, COMPLETE	
111	1-543-653-11	CORE ASSY, BEAD(DIVISION TYPE)		126	Δ 1-532-742-11	FUSE, GLASS TUBE 1.6A/125V	
112	*4-043-690-01	BRACKET, MAIN		127	*3-687-542-41	SPACER, PC BOARD SPACE (20M2MDU)	
113	*A-1298-297-A	A BOARD, COMPLETE		128	*A-1390-779-A	S BOARD, COMPLETE (20M2MDU)	
114	Δ 1-453-234-11	TRANSFORMER ASSY FLYBACK					
115	*A-1304-141-A	M BOARD, COMPLETE					

7-4. PICTURE TUBE [20M2MDU/E/A]

- : 7-685-648-79 +BVTP 3X12
- △ : 7-685-663-71 +BVTP 4X16
- : 7-682-563-09 +B 4X12
- ★ : 7-685-883-09 +BVTT 4X12
- ◇ : 7-685-664-79 +P 4X20
- ▽ : 7-685-661-14 +BVTP 4X12

The components identified by shading and mark △ are critical for safety. Replace only with part number specified.

Les composants identifiés par une trame et une marque △ sont critiques pour la sécurité. Ne les remplacer que par une pièce portant le numéro spécifié.

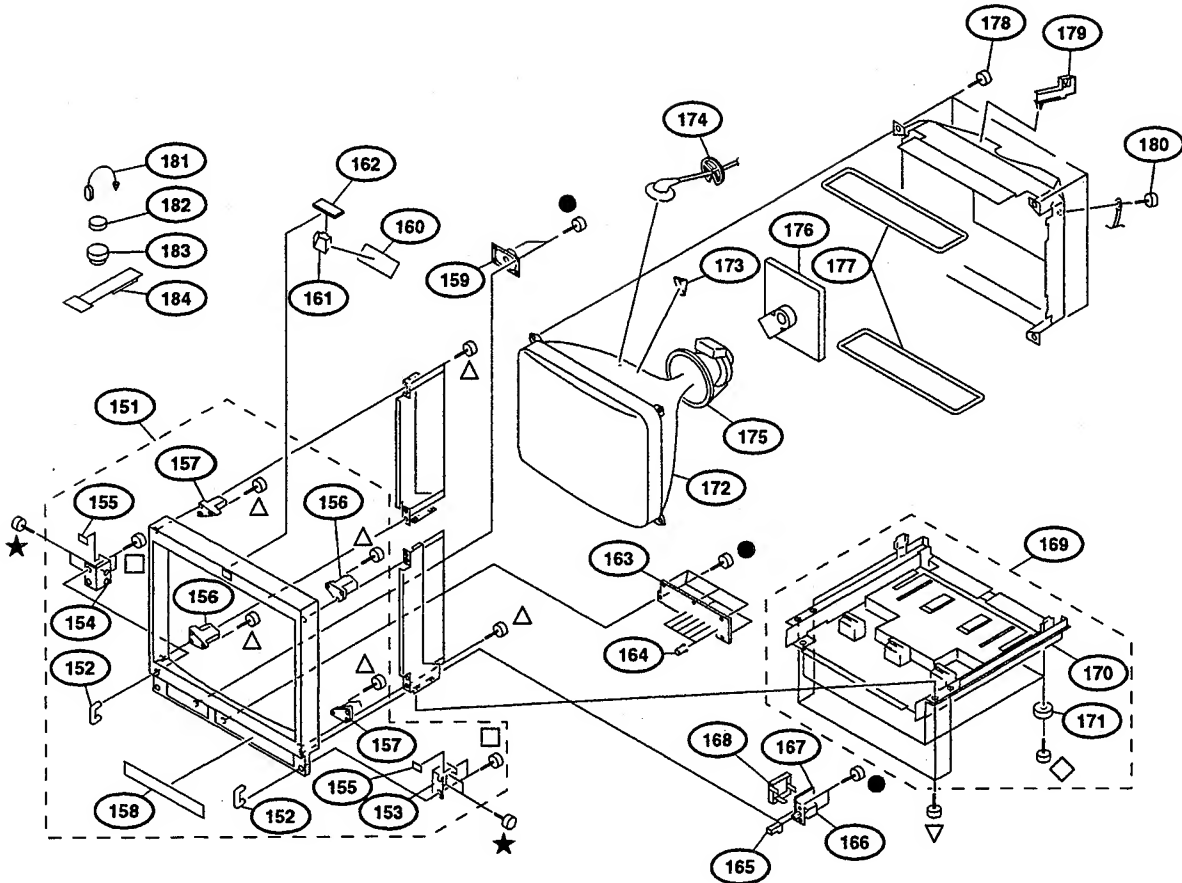

REF. NO.	PART NO.	DESCRIPTION	REMARK	REF. NO.	PART NO.	DESCRIPTION	REMARK
151	X-4035-198-1	BEZEL ASSY	152-158	168	4-043-681-01	COVER, AC SWITCH	
152	4-052-200-11	HANDLE, PROTECTOR		169	*X-4032-770-1	CABINET ASSY, BOTTOM	170,171
153	*4-043-670-01	REINFORCEMENT (R), HANDLE		170	*4-043-674-03	CABINET, BOTTOM	
154	*4-043-669-01	REINFORCEMENT (L), HANDLE		171	4-901-947-01	LEG	
155	*4-043-797-01	PLATE, BLIND		172	△ 8-736-135-05	PICTURE TUBE 20FZ5 (DARK) (M49JGH11X)	
156	*4-043-672-01	BRACKET (A), PICTURE TUBE		173	3-703-961-01	SPACER, DY	
157	*4-043-673-01	BRACKET (B), PICTURE TUBE		174	3-704-372-01	HOLDER, HV CABLE	
158	*4-057-975-41	LABEL, CONTROL		175	△ 1-451-349-12	DEFLECTION YOKE (Y20FZA)	
159	1-544-063-12	SPEAKER		176	*A-1331-763-A	C BOARD, COMPLETE	
160	4-044-606-01	CUSHION, TALLY		177	△ 1-426-505-11	COIL, DEMAGNETIZATION	
161	*4-043-671-01	REFLECTOR, LED		178	4-365-808-01	SCREW (5), TAPPING	
162	*A-1390-778-A	X BOARD, COMPLETE		179	*4-387-284-01	HOLDER, LEAD	
163	*A-1372-410-A	H BOARD, COMPLETE		180	4-389-025-01	SCREW (M4) (EXT TOOTH WASHER)	
164	4-043-802-11	KNOB, CONTROL		181	4-308-870-00	CLIP, LEAD WIRE	
165	4-043-683-01	BUTTON, POWER SWITCH		182	1-452-032-00	MAGNET, DISK ; 10mmφ	
166	△ 1-692-921-11	SWITCH, PUSH (A.C. POWER)		183	1-452-094-00	MAGNET, ROTABLE DISK ; 15mmφ	
167	*A-1388-204-A	J BOARD, COMPLETE		184	4-051-736-21	PIECE A(90), CONV. CORRECT	

SECTION 8 ELECTRICAL PARTS LIST



NOTE:

Les composants identifiés par une trame et une marque Δ sont critiques pour la sécurité. Ne les remplacer que par une pièce portant le numéro spécifié.

The components identified by shading and mark Δ are critical for safety. Replace only with part number specified.

• The components identified by \square in this manual have been carefully factory-selected for each set in order to satisfy regulations regarding X-ray radiation. Should replacement be required, replace only with the value originally used.

• Items marked " * " are not stocked since they are seldom required for routine service. Some delay should be anticipated when ordering these items.

• All variable and adjustable resistors have characteristic curve B, unless otherwise noted.

RESISTORS

- All resistors are in ohms
- F : nonflammable

When indicating parts by reference number, please include the board name.

• CAPACITORS

PF : $\mu\mu$ F

• There are some cases the reference number on one board overlaps on the other board. Therefore, when ordering parts by the reference number, please include the board name.

REF. NO.	PART NO.	DESCRIPTION	REMARK	REF. NO.	PART NO.	DESCRIPTION	REMARK
* A-1298-296-A	A BOARD, COMPLETE (14inch model)	*****		C174	1-163-243-11	CERAMIC CHIP 47PF	5% 50V
				C200	1-126-963-11	ELECT 4.7MF	20% 50V
	1-540-044-11	SOCKET, IC		C201	1-137-353-11	MYLAR 0.047MF	10% 100V
* 4-043-994-01	PLATE (CF), SHIELD			C202	1-163-017-00	CERAMIC CHIP 0.0047MF	10% 50V
* 4-058-301-01	RING, SHORT			C203	1-126-963-11	ELECT 4.7MF	20% 50V
4-382-854-11	SCREW (M3X10), P, SW (+)			C204	1-126-964-11	ELECT 10MF	20% 50V
7-682-948-01	SCREW +PSW 3X8			C205	1-126-767-11	ELECT 1000MF	20% 16V
7-685-663-79	SCREW +BVTP 4X16 TYPE2 IT-3			C206	1-128-526-11	ELECT 100MF	20% 25V
	<BAND PASS FILTER>			C207	1-104-665-11	ELECT 100MF	20% 25V
BPF400	1-236-363-11	FILTER, BAND PASS		C208	1-126-964-11	ELECT 10MF	20% 50V
	<CAPACITOR>			C209	1-126-963-11	ELECT 4.7MF	20% 50V
C105	1-163-251-11	CERAMIC CHIP 100PF	5% 50V	C304	1-164-004-11	CERAMIC CHIP 0.1MF	10% 25V
C106	1-163-251-11	CERAMIC CHIP 100PF	5% 50V	C305	1-163-259-91	CERAMIC CHIP 220PF	5% 50V
C114	1-163-031-11	CERAMIC CHIP 0.01MF	50V	C306	1-163-031-11	CERAMIC CHIP 0.01MF	50V
C116	1-163-031-11	CERAMIC CHIP 0.01MF	50V	C310	1-164-004-11	CERAMIC CHIP 0.1MF	10% 25V
C117	1-163-031-11	CERAMIC CHIP 0.01MF	50V	C311	1-163-809-11	CERAMIC CHIP 0.047MF	10% 25V
C118	1-163-259-91	CERAMIC CHIP 220PF	5% 50V	C312	1-126-961-11	ELECT 2.2MF	20% 50V
C119	1-165-319-11	CERAMIC CHIP 0.1MF	50V	C313	1-163-145-00	CERAMIC CHIP 0.0015MF	5% 50V
C121	1-163-237-11	CERAMIC CHIP 27PF	5% 50V	C314	1-163-249-11	CERAMIC CHIP 82PF	5% 50V
C123	1-165-319-11	CERAMIC CHIP 0.1MF	50V	C315	1-126-964-11	ELECT 10MF	20% 50V
C124	1-163-251-11	CERAMIC CHIP 100PF	5% 50V	C316	1-104-664-11	ELECT 47MF	20% 25V
C132	1-163-141-00	CERAMIC CHIP 0.001MF	5% 50V	C318	1-126-964-11	ELECT 10MF	20% 50V
C133	1-163-251-11	CERAMIC CHIP 100PF	5% 50V	C325	1-126-964-11	ELECT 10MF	20% 50V
C134	1-163-251-11	CERAMIC CHIP 100PF	5% 50V	C328	1-163-031-11	CERAMIC CHIP 0.01MF	50V
C135	1-163-251-11	CERAMIC CHIP 100PF	5% 50V	C340	1-163-031-11	CERAMIC CHIP 0.01MF	50V
C136	1-163-251-11	CERAMIC CHIP 100PF	5% 50V	C343	1-163-031-11	CERAMIC CHIP 0.01MF	50V
C140	1-164-004-11	CERAMIC CHIP 0.1MF	10% 25V	C349	1-163-141-00	CERAMIC CHIP 0.001MF	5% 50V
C141	1-164-161-11	CERAMIC CHIP 0.0022MF	10% 50V	C350	1-163-141-00	CERAMIC CHIP 0.001MF	5% 50V
C142	1-163-259-91	CERAMIC CHIP 220PF	5% 50V	C352	1-163-031-11	CERAMIC CHIP 0.01MF	50V
C143	1-165-319-11	CERAMIC CHIP 0.1MF	50V	C353	1-165-319-11	CERAMIC CHIP 0.1MF	50V
C144	1-165-319-11	CERAMIC CHIP 0.1MF	50V	C354	1-163-121-00	CERAMIC CHIP 150PF	5% 50V
C145	1-165-319-11	CERAMIC CHIP 0.1MF	50V	C355	1-126-960-11	ELECT 1MF	20% 50V
C154	1-163-037-11	CERAMIC CHIP 0.022MF	10% 50V	C356	1-126-963-11	ELECT 4.7MF	20% 50V
C155	1-163-023-00	CERAMIC CHIP 0.015MF	10% 50V	C357	1-163-031-11	CERAMIC CHIP 0.01MF	50V
C156	1-163-019-00	CERAMIC CHIP 0.0068MF	10% 50V	C358	1-163-031-11	CERAMIC CHIP 0.01MF	50V
C157	1-163-019-00	CERAMIC CHIP 0.0068MF	10% 50V	C359	1-104-664-11	ELECT 47MF	20% 25V
C158	1-163-809-11	CERAMIC CHIP 0.047MF	10% 25V	C360	1-164-232-11	CERAMIC CHIP 0.01MF	10% 50V
C159	1-164-344-11	CERAMIC CHIP 0.068MF	10% 25V	C361	1-163-031-11	CERAMIC CHIP 0.01MF	50V
C161	1-104-664-11	ELECT 47MF	20% 25V	C362	1-163-031-11	CERAMIC CHIP 0.01MF	50V
C162	1-163-141-00	CERAMIC CHIP 0.001MF	5% 50V	C363	1-163-099-00	CERAMIC CHIP 18PF	5% 50V
C164	1-165-319-11	CERAMIC CHIP 0.1MF	50V	C364	1-163-031-11	CERAMIC CHIP 0.01MF	50V
C165	1-165-319-11	CERAMIC CHIP 0.1MF	50V	C365	1-106-343-00	MYLAR 0.001MF	10% 100V
C166	1-164-004-11	CERAMIC CHIP 0.1MF	10% 25V	C366	1-163-031-11	CERAMIC CHIP 0.01MF	50V
C167	1-126-925-11	ELECT 470MF	20% 10V	C367	1-163-031-11	CERAMIC CHIP 0.01MF	50V
C168	1-126-925-11	ELECT 470MF	20% 10V	C368	1-124-261-00	ELECT 10MF	20% 50V
C169	1-164-232-11	CERAMIC CHIP 0.01MF	10% 50V	C369	1-164-298-11	CERAMIC CHIP 0.15MF	10% 25V
C171	1-163-251-11	CERAMIC CHIP 100PF	5% 50V	C370	1-104-664-11	ELECT 47MF	20% 25V
C172	1-163-123-00	CERAMIC CHIP 180PF	5% 50V	C371	1-104-664-11	ELECT 47MF	20% 25V
C173	1-163-123-00	CERAMIC CHIP 180PF	5% 50V	C372	1-163-031-11	CERAMIC CHIP 0.01MF	50V
				C373	1-163-141-00	CERAMIC CHIP 0.001MF	5% 50V
				C374	1-126-960-11	ELECT 1MF	20% 50V
				C375	1-163-259-91	CERAMIC CHIP 220PF	5% 50V
				C376	1-126-959-11	ELECT 0.47MF	20% 50V

A

Les composants identifiés par une trame et une marque Δ sont critiques pour la sécurité. Ne les remplacer que par une pièce portant le numéro spécifié.

The components identified by shading and mark Δ are critical for safety. Replace only with part number specified.

REF. NO.	PART NO.	DESCRIPTION	REMARK
C377	1-163-809-11	CERAMIC CHIP 0.047MF	10% 25V
C378	1-163-809-11	CERAMIC CHIP 0.047MF	10% 25V
C379	1-163-031-11	CERAMIC CHIP 0.01MF	50V
C380	1-126-767-11	ELECT 1000MF	20% 16V
C381	1-163-031-11	CERAMIC CHIP 0.01MF	50V
C382	1-163-243-11	CERAMIC CHIP 47PF	5% 50V
C383	1-104-664-11	ELECT 47MF	20% 25V
C384	1-163-249-11	CERAMIC CHIP 82PF	5% 50V
C385	1-104-664-11	ELECT 47MF	20% 25V
C386	1-124-261-00	ELECT 10MF	20% 50V
C387	1-163-141-00	CERAMIC CHIP 0.001MF	5% 50V
C388	1-124-261-00	ELECT 10MF	20% 50V
C390	1-163-243-11	CERAMIC CHIP 47PF	5% 50V
C391	1-104-664-11	ELECT 47MF	20% 25V
C392	1-164-298-11	CERAMIC CHIP 0.15MF	10% 25V
C393	1-164-298-11	CERAMIC CHIP 0.15MF	10% 25V
C394	1-104-664-11	ELECT 47MF	20% 25V
C395	1-163-235-11	CERAMIC CHIP 22PF	5% 50V
C396	1-164-299-11	CERAMIC CHIP 0.22MF	10% 25V
C397	1-104-664-11	ELECT 47MF	20% 25V
C398	1-104-664-11	ELECT 47MF	20% 25V
C399	1-104-664-11	ELECT 47MF	20% 25V
C400	1-164-004-11	CERAMIC CHIP 0.1MF	10% 25V
C401	1-164-346-11	CERAMIC CHIP 1MF	16V
C407	1-104-664-11	ELECT 47MF	20% 25V
C409	1-163-031-11	CERAMIC CHIP 0.01MF	50V
C411	1-164-004-11	CERAMIC CHIP 0.1MF	10% 25V
C414	1-163-031-11	CERAMIC CHIP 0.01MF	50V
C415	1-126-964-11	ELECT 10MF	20% 50V
C416	1-164-232-11	CERAMIC CHIP 0.01MF	10% 50V
C417	1-164-232-11	CERAMIC CHIP 0.01MF	10% 50V
C418	1-164-182-11	CERAMIC CHIP 0.0033MF	10% 50V
C419	1-126-925-11	ELECT 470MF	20% 10V
C420	1-163-809-11	CERAMIC CHIP 0.047MF	10% 25V
C421	1-164-222-11	CERAMIC CHIP 0.22MF	25V
C422	1-126-960-11	ELECT 1MF	20% 50V
C423	1-163-809-11	CERAMIC CHIP 0.047MF	10% 25V
C424	1-163-809-11	CERAMIC CHIP 0.047MF	10% 25V
C426	1-163-243-11	CERAMIC CHIP 47PF	5% 50V
C427	1-163-031-11	CERAMIC CHIP 0.01MF	50V
C429	1-163-031-11	CERAMIC CHIP 0.01MF	50V
C430	1-104-661-91	ELECT 330MF	20% 16V
C431	1-165-319-11	CERAMIC CHIP 0.1MF	50V
C433	1-163-235-11	CERAMIC CHIP 22PF	5% 50V
C434	1-164-004-11	CERAMIC CHIP 0.1MF	10% 25V
C435	1-163-089-00	CERAMIC CHIP 6PF	0.25PF 50V
C437	1-164-004-11	CERAMIC CHIP 0.1MF	10% 25V
C439	1-163-809-11	CERAMIC CHIP 0.047MF	10% 25V
C440	1-164-004-11	CERAMIC CHIP 0.1MF	10% 25V
C441	1-126-962-11	ELECT 3.3MF	20% 50V
C442	1-163-809-11	CERAMIC CHIP 0.047MF	10% 25V
C443	1-163-243-11	CERAMIC CHIP 47PF	5% 50V
C444	1-165-319-11	CERAMIC CHIP 0.1MF	50V
C446	1-163-089-00	CERAMIC CHIP 6PF	0.25PF 50V
C447	1-163-263-11	CERAMIC CHIP 330PF	5% 50V
C448	1-163-243-11	CERAMIC CHIP 47PF	5% 50V
C449	1-163-227-11	CERAMIC CHIP 10PF	0.5PF 50V
C450	1-163-809-11	CERAMIC CHIP 0.047MF	10% 25V
C451	1-164-004-11	CERAMIC CHIP 0.1MF	10% 25V
C452	1-163-263-11	CERAMIC CHIP 330PF	5% 50V
C453	1-164-004-11	CERAMIC CHIP 0.1MF	10% 25V
C454	1-163-243-11	CERAMIC CHIP 47PF	5% 50V
C455	1-163-263-11	CERAMIC CHIP 330PF	5% 50V
C456	1-163-089-00	CERAMIC CHIP 6PF	0.25PF 50V
C457	1-164-004-11	CERAMIC CHIP 0.1MF	10% 25V
C458	1-163-249-11	CERAMIC CHIP 82PF	5% 50V
C459	1-165-319-11	CERAMIC CHIP 0.1MF	50V
C460	1-164-004-11	CERAMIC CHIP 0.1MF	10% 25V
C461	1-163-119-00	CERAMIC CHIP 120PF	5% 50V

REF. NO.	PART NO.	DESCRIPTION	REMARK
C462	1-164-004-11	CERAMIC CHIP 0.1MF	10% 25V
C463	1-164-004-11	CERAMIC CHIP 0.1MF	10% 25V
C464	1-164-299-11	CERAMIC CHIP 0.22MF	10% 25V
C465	1-163-231-11	CERAMIC CHIP 15PF	5% 50V
C466	1-163-119-00	CERAMIC CHIP 120PF	5% 50V
C467	1-163-119-00	CERAMIC CHIP 120PF	5% 50V
C469	1-163-037-11	CERAMIC CHIP 0.022MF	10% 50V
C470	1-163-243-11	CERAMIC CHIP 47PF	5% 50V
C471	1-163-105-00	CERAMIC CHIP 33PF	5% 50V
C472	1-163-031-11	CERAMIC CHIP 0.01MF	50V
C473	1-163-031-11	CERAMIC CHIP 0.01MF	50V
C475	1-163-031-11	CERAMIC CHIP 0.01MF	50V
C476	1-163-031-11	CERAMIC CHIP 0.01MF	50V
C477	1-164-299-11	CERAMIC CHIP 0.22MF	10% 25V
C478	1-126-964-11	ELECT 10MF	20% 50V
C479	1-163-121-00	CERAMIC CHIP 150PF	5% 50V
C483	1-163-249-11	CERAMIC CHIP 82PF	5% 50V
C484	1-163-113-00	CERAMIC CHIP 68PF	5% 50V
C485	1-163-113-00	CERAMIC CHIP 68PF	5% 50V
C486	1-163-249-11	CERAMIC CHIP 82PF	5% 50V
C487	1-163-235-11	CERAMIC CHIP 22PF	5% 50V
C490	1-164-336-11	CERAMIC CHIP 0.33MF	25V
C491	1-164-336-11	CERAMIC CHIP 0.33MF	25V
C492	1-164-336-11	CERAMIC CHIP 0.33MF	25V
C493	1-104-760-11	CERAMIC CHIP 0.047MF	10% 50V
C494	1-164-005-11	CERAMIC CHIP 0.47MF	25V
C495	1-126-964-11	ELECT 10MF	20% 50V
C496	1-163-249-11	CERAMIC CHIP 82PF	5% 50V
C497	1-163-011-11	CERAMIC CHIP 0.0015MF	10% 50V
C498	1-126-961-11	ELECT 2.2MF	20% 50V
C499	1-163-031-11	CERAMIC CHIP 0.01MF	50V
C500	1-164-004-11	CERAMIC CHIP 0.1MF	10% 25V
C501	1-164-182-11	CERAMIC CHIP 0.0033MF	10% 50V
C502	1-163-141-00	CERAMIC CHIP 0.001MF	5% 50V
C503	1-163-251-11	CERAMIC CHIP 100PF	5% 50V
C504	1-136-495-11	FILM 0.068MF	5% 50V
C505	1-163-199-00	CERAMIC CHIP 560PF	5% 50V
C506	1-126-959-11	ELECT 0.47MF	20% 50V
C507	1-128-526-11	ELECT 100MF	20% 25V
C508	1-130-497-00	MYLAR 0.15MF	5% 50V
C509	1-128-566-11	ELECT 470MF	20% 100V
C511	1-107-368-11	FILM 0.047MF	10% 200V
C512	1-126-959-11	ELECT 0.47MF	20% 50V
C513	1-124-261-00	ELECT 10MF	20% 50V
C514	Δ 1-130-338-91	FILM 0.01MF	5% 630V
C515	1-163-809-11	CERAMIC CHIP 0.047MF	10% 25V
C516	1-102-030-00	CERAMIC 330PF	10% 500V
C517	1-163-024-00	CERAMIC CHIP 0.018MF	10% 50V
C518	1-107-947-11	ELECT 220MF	20% 160V
C519	1-163-017-00	CERAMIC CHIP 0.0047MF	10% 50V
C520	1-163-257-11	CERAMIC CHIP 180PF	5% 50V
C521	1-162-114-00	CERAMIC 0.0047MF	2KV
C522	1-126-768-11	ELECT 2200MF	20% 16V
C523	1-107-902-11	ELECT 1MF	20% 50V
C525	Δ 1-136-079-11	FILM 0.01MF	3% 2KV
C526	Δ 1-162-116-91	CERAMIC 680PF	10% 2KV
C527	1-162-134-11	CERAMIC 470PF	10% 2KV
C529	1-107-901-11	ELECT 0.47MF	20% 50V
C530	1-104-666-11	ELECT 220MF	20% 25V
C531	1-104-664-11	ELECT 47MF	20% 25V
C532	1-163-031-11	CERAMIC CHIP 0.01MF	50V
C533	1-102-212-00	CERAMIC 820PF	10% 500V
C534	1-107-662-11	ELECT 22MF	20% 250V
C537	1-126-971-11	ELECT 470MF	20% 50V
C538	1-137-150-11	MYLAR 0.01MF	10% 100V
C539	1-130-480-00	FILM 0.0056MF	5% 50V
C540	1-163-133-00	CERAMIC CHIP 470PF	5% 50V
C541	1-107-905-11	ELECT 4.7MF	20% 50V
C542	1-136-481-11	MYLAR 0.0022MF	10% 100V



REF. NO.	PART NO.	DESCRIPTION	REMARK	REF. NO.	PART NO.	DESCRIPTION	REMARK	
C543	1-136-481-11	MYLAR	0.0022MF 10%	100V	C1321	1-104-664-11	ELECT 47MF 20%	25V
C544	1-137-150-11	MYLAR	0.01MF 10%	100V	C1322	1-126-934-11	ELECT 220MF 20%	16V
C545	1-102-212-00	CERAMIC	820PF 10%	500V	C1323	1-163-031-11	CERAMIC CHIP 0.01MF	50V
C546	1-163-119-00	CERAMIC CHIP	120PF 5%	50V	C1324	1-163-031-11	CERAMIC CHIP 0.01MF	50V
C547	1-163-251-11	CERAMIC CHIP	100PF 5%	50V	C1325	1-163-031-11	CERAMIC CHIP 0.01MF	50V
C548	1-102-212-00	CERAMIC	820PF 10%	500V	C1326	1-104-664-11	ELECT 47MF 20%	25V
C549	1-107-906-11	ELECT	10MF 20%	50V	C1327	1-163-031-11	CERAMIC CHIP 0.01MF	50V
C550	1-107-905-11	ELECT	4.7MF 20%	50V	C1328	1-163-031-11	CERAMIC CHIP 0.01MF	50V
C551	1-106-375-12	MYLAR	0.022MF 10%	100V	C1329	1-126-964-11	ELECT 10MF 20%	50V
C552	1-107-889-11	ELECT	220MF 20%	25V	C1330	1-163-031-11	CERAMIC CHIP 0.01MF	50V
C554	1-130-736-11	FILM	0.01MF 5%	50V	C1331	1-104-664-11	ELECT 47MF 20%	25V
C555	1-126-964-11	ELECT	10MF 20%	50V	C1332	1-104-664-11	ELECT 47MF 20%	25V
C556	1-126-964-11	ELECT	10MF 20%	50V	C1333	1-104-664-11	ELECT 47MF 20%	25V
C557	1-106-381-12	MYLAR	0.039MF 10%	100V	C1334	1-163-227-11	CERAMIC CHIP 10PF 0.5PF	50V
C558	1-126-960-11	ELECT	1MF 20%	50V	C1335	1-104-664-11	ELECT 47MF 20%	25V
C559	1-136-173-00	FILM	0.47MF 5%	50V	C1336	1-104-664-11	ELECT 47MF 20%	25V
C561	1-136-159-00	FILM	0.033MF 5%	50V	C1338	1-163-031-11	CERAMIC CHIP 0.01MF	50V
C564	1-126-964-11	ELECT	10MF 20%	50V	C1339	1-163-031-11	CERAMIC CHIP 0.01MF	50V
C565	1-126-960-11	ELECT	1MF 20%	50V	C1340	1-163-031-11	CERAMIC CHIP 0.01MF	50V
C566	1-137-150-11	MYLAR	0.01MF 10%	100V	C1341	1-163-275-11	CERAMIC CHIP 0.001MF 5%	50V
C567	1-136-499-11	FILM	0.047MF 5%	50V	C1342	1-163-105-00	CERAMIC CHIP 33PF 5%	50V
C568	1-126-960-11	ELECT	1MF 20%	50V	C1343	1-163-113-00	CERAMIC CHIP 68PF 5%	50V
C569	1-131-351-00	TANTALUM	4.7MF 10%	25V	C1344	1-163-083-00	CERAMIC CHIP 1PF 0.25PF	50V
C570	1-126-767-11	ELECT	1000MF 20%	16V	C1345	1-124-261-00	ELECT 10MF 20%	50V
C571	1-163-022-00	CERAMIC CHIP	0.012MF 10%	50V	C1346	1-124-589-11	ELECT 47MF 20%	16V
C572	1-104-709-11	ELECT	4.7MF 0	160V	C1347	1-163-031-11	CERAMIC CHIP 0.01MF	50V
C573	1-136-173-00	FILM	0.47MF 5%	50V	C1348	1-163-127-00	CERAMIC CHIP 270PF 5%	50V
C576	1-102-244-00	CERAMIC	220PF 10%	500V	C1349	1-163-117-00	CERAMIC CHIP 100PF 5%	50V
C577	1-107-906-11	ELECT	10MF 20%	50V	C1350	1-164-232-11	CERAMIC CHIP 0.01MF 10%	50V
C578	1-136-112-00	FILM	1.4MF 5%	200V	C1351	1-126-160-11	ELECT 1MF 20%	50V
C579	1-107-910-11	ELECT	100MF 20%	50V	C1352	1-163-023-00	CERAMIC CHIP 0.015MF 10%	50V
C580	1-136-756-11	FILM	0.24MF 5%	200V	C1353	1-163-031-11	CERAMIC CHIP 0.01MF	50V
C581	1-126-963-11	ELECT	4.7MF 20%	50V	C1354	1-163-121-00	CERAMIC CHIP 150PF 5%	50V
C582	1-102-002-00	CERAMIC	680PF 10%	500V	C1355	1-163-259-91	CERAMIC CHIP 220PF 5%	50V
C583	1-136-828-11	FILM	1.8MF 5%	200V	C1356	1-163-235-11	CERAMIC CHIP 22PF 5%	50V
C584	1-107-949-11	ELECT	2.2MF 20%	160V	C1357	1-104-661-91	ELECT 330MF 20%	16V
C585	1-107-960-11	ELECT	4.7MF 20%	250V	C1358	1-124-589-11	ELECT 47MF 20%	16V
C586	1-126-942-61	ELECT	1000MF 20%	25V	C1359	1-163-263-11	CERAMIC CHIP 330PF 5%	50V
C587	1-102-030-00	CERAMIC	330PF 10%	500V	C1360	1-164-161-11	CERAMIC CHIP 0.0022MF 10%	50V
C588	1-107-906-11	ELECT	10MF 20%	50V	C1362	1-163-249-11	CERAMIC CHIP 82PF 5%	50V
C589	1-102-030-00	CERAMIC	330PF 10%	500V	C1363	1-163-235-11	CERAMIC CHIP 22PF 5%	50V
C590	1-107-903-11	ELECT	2.2MF 20%	50V	C1364	1-163-133-00	CERAMIC CHIP 470PF 5%	50V
C591	1-107-365-11	FILM	0.015MF 10%	200V	C1365	1-163-227-11	CERAMIC CHIP 10PF 0.5PF	50V
C592	1-107-635-11	ELECT	4.7MF 20%	160V	C1366	1-104-664-11	ELECT 47MF 20%	25V
C593	1-165-319-11	CERAMIC CHIP	0.1MF 50V		C1367	1-104-664-11	ELECT 47MF 20%	25V
C594	1-163-229-11	CERAMIC CHIP	12PF 5%	50V	C1372	1-104-664-11	ELECT 47MF 20%	25V
C595	1-107-889-11	ELECT	220MF 20%	25V	C1373	1-104-664-11	ELECT 47MF 20%	25V
C596	1-104-665-11	ELECT	100MF 20%	25V	C1374	1-104-664-11	ELECT 47MF 20%	25V
C597	1-164-346-11	CERAMIC CHIP	1MF 16V		C1375	1-126-963-11	ELECT 4.7MF 20%	50V
C598	1-164-346-11	CERAMIC CHIP	1MF 16V		C1378	1-163-231-11	CERAMIC CHIP 15PF 5%	50V
C599	1-124-261-00	ELECT	10MF 20%	50V	C1391	1-136-165-00	FILM 0.1MF 5%	50V
C1300	1-104-664-11	ELECT	47MF 20%	25V	C1394	1-126-967-11	ELECT 47MF 20%	50V
C1302	1-163-133-00	CERAMIC CHIP	470PF 5%	50V	C1395	1-126-967-11	ELECT 47MF 20%	50V
C1304	1-104-664-11	ELECT	47MF 20%	25V	C1396	1-163-275-11	CERAMIC CHIP 0.001MF 5%	50V
C1305	1-104-664-11	ELECT	47MF 20%	25V	C1397	1-163-031-11	CERAMIC CHIP 0.01MF	50V
C1307	1-163-031-11	CERAMIC CHIP	0.01MF	50V	C1398	1-124-234-00	ELECT 22MF 20%	16V
C1308	1-126-933-11	ELECT	100MF 20%	10V	C1399	1-104-664-11	ELECT 47MF 20%	25V
C1309	1-163-257-11	CERAMIC CHIP	180PF 5%	50V	C1400	1-163-031-11	CERAMIC CHIP 0.01MF	50V
C1311	1-104-664-11	ELECT	47MF 20%	25V	C1401	1-136-173-00	FILM 0.47MF 5%	50V
C1312	1-163-031-11	CERAMIC CHIP	0.01MF	50V	C1402	1-163-031-11	CERAMIC CHIP 0.01MF	50V
C1313	1-163-031-11	CERAMIC CHIP	0.01MF	50V	C1403	1-136-173-00	FILM 0.47MF 5%	50V
C1314	1-104-664-11	ELECT	47MF 20%	25V	C1404	1-164-299-11	CERAMIC CHIP 0.22MF 10%	25V
C1315	1-104-664-11	ELECT	47MF 20%	25V	C1408	1-163-113-00	CERAMIC CHIP 68PF 5%	50V
C1316	1-163-031-11	CERAMIC CHIP	0.01MF	50V	C1500	1-126-768-11	ELECT 2200MF 20%	16V
C1317	1-104-664-11	ELECT	47MF 20%	25V	C1501	1-126-925-11	ELECT 470MF 20%	10V
C1318	1-104-664-11	ELECT	47MF 20%	25V	C1505	1-136-165-00	FILM 0.1MF 5%	50V
C1319	1-124-234-00	ELECT	22MF 20%	16V	C1506	1-104-661-91	ELECT 330MF 20%	16V
C1320	1-104-664-11	ELECT	47MF 20%	25V	C1507	1-163-141-00	CERAMIC CHIP 0.001MF 5%	50V

A

Les composants identifiés par une trame et une marque Δ sont critiques pour la sécurité. Ne les remplacer que par une pièce portant le numéro spécifique.

The components identified by shading and mark Δ are critical for safety. Replace only with part number specified.

REF. NO.	PART NO.	DESCRIPTION	REMARK
C1508	1-126-963-11	ELECT 4.7MF 20% 50V	
C1509	1-126-964-11	ELECT 10MF 20% 50V	
C1510	1-126-963-11	ELECT 4.7MF 20% 50V	
C1511	1-164-232-11	CERAMIC CHIP 0.01MF 10% 50V	
C1512	1-126-963-11	ELECT 4.7MF 20% 50V	
C1513	1-163-197-00	CERAMIC CHIP 470PF 5% 50V	
C1514	1-130-477-00	MYLAR 0.0033MF 5% 50V	
C1515	1-126-964-11	ELECT 10MF 20% 50V	
C1516	1-163-063-91	CERAMIC CHIP 0.022MF 10% 50V	
C1517	1-128-526-11	ELECT 100MF 20% 10V	
C1518	1-107-909-11	ELECT 47MF 20% 16V	
C1521	1-163-243-11	CERAMIC CHIP 47PF 5% 50V	
C1530	1-163-031-11	CERAMIC CHIP 0.01MF 50V	
C1538	1-163-251-11	CERAMIC CHIP 100PF 5% 50V	
C1539	1-163-119-00	CERAMIC CHIP 120PF 5% 50V	
C1540	1-163-263-11	CERAMIC CHIP 330PF 5% 50V	
C1541	1-163-121-00	CERAMIC CHIP 150PF 5% 50V	
C1542	1-163-121-00	CERAMIC CHIP 150PF 5% 50V	
C2501	1-164-232-11	CERAMIC CHIP 0.01MF 10% 50V	
C2502	1-164-232-11	CERAMIC CHIP 0.01MF 10% 50V	

C2510 Δ 1-130-061-91 FILM 0.0015MF 5% 630V

<CONNECTOR>

CN101	* 1-573-979-11	CONNECTOR, BOARD TO BOARD 11P	
CN102	* 1-564-514-11	PLUG, CONNECTOR 11P	
CN104	* 1-564-506-11	PLUG, CONNECTOR 3P	
CN105	* 1-766-745-11	CONNECTOR, BOARD TO BOARD 12P	
CN201	* 1-564-506-11	PLUG, CONNECTOR 3P	
CN301	* 1-564-514-11	PLUG, CONNECTOR 11P	
CN302	* 1-564-510-11	PLUG, CONNECTOR 7P	
CN305	1-779-070-21	PIN, CONNECTOR 12P	
CN306	* 1-564-506-11	PLUG, CONNECTOR 3P	
CN401	* 1-564-511-11	PLUG, CONNECTOR 8P	
CN402	* 1-564-515-11	PLUG, CONNECTOR 12P	
CN501	* 1-580-798-11	CONNECTOR PIN (DY) 6P	
CN502	* 1-573-964-11	PIN, CONNECTOR (PC BOARD) 6P	
CN503	* 1-573-964-11	PIN, CONNECTOR (PC BOARD) 6P	
CN504	* 1-564-506-11	PLUG, CONNECTOR 3P	
CN505	* 1-564-506-11	PLUG, CONNECTOR 3P	
CN507	1-695-915-11	TAB (CONTACT)	

<COMPOSITION CIRCUIT BLOCK>

CP300	1-236-366-11	MODULE, TRAP	
CP301	1-236-365-11	MODULE, TRAP	
CP302	1-808-654-21	MODULE	
CP303	1-466-162-61	FILTER BLOCK, COM (CFB-4)	

<DIODE>

D100	8-719-404-49	DIODE MA111	
D101	8-719-800-76	DIODE 1SS226	
D102	8-719-800-76	DIODE 1SS226	
D103	8-719-045-70	DIODE 1SV230TPH3	
D104	8-719-800-76	DIODE 1SS226	
D105	8-719-800-76	DIODE 1SS226	
D107	8-719-800-76	DIODE 1SS226	
D108	8-719-104-34	DIODE 1S2836	
D109	8-719-801-78	DIODE 1SS184	
D111	8-719-977-05	DIODE DTZ6.2	
D114	8-719-404-49	DIODE MA111	
D115	8-719-977-05	DIODE DTZ6.2	
D116	8-719-404-49	DIODE MA111	
D117	8-719-920-76	DIODE 1S2076	
D200	8-719-977-46	DIODE DTZ13C	
D300	8-719-025-07	DIODE 1SV232-TPH3	
D301	8-719-404-49	DIODE MA111	
D303	8-719-977-05	DIODE DTZ6.2	

REF. NO.	PART NO.	DESCRIPTION	REMARK
D304	8-719-801-78	DIODE 1SS184	
D305	8-719-800-76	DIODE 1SS226	
D307	8-719-404-49	DIODE MA111	
D308	8-719-404-49	DIODE MA111	
D309	8-719-404-49	DIODE MA111	
D310	8-719-104-34	DIODE 1S2836	
D311	8-719-045-70	DIODE 1SV230TPH3	
D313	8-719-801-78	DIODE 1SS184	
D314	8-719-404-49	DIODE MA111	
D315	8-719-404-49	DIODE MA111	
D317	8-719-404-49	DIODE MA111	
D320	8-719-404-49	DIODE MA111	
D322	8-719-404-49	DIODE MA111	
D323	8-719-404-49	DIODE MA111	
D324	8-719-404-49	DIODE MA111	
D325	8-719-801-78	DIODE 1SS184	
D326	8-719-404-49	DIODE MA111	
D327	8-719-104-34	DIODE 1S2836	
D332	8-719-404-49	DIODE MA111	
D333	8-719-404-49	DIODE MA111	
D335	8-719-404-49	DIODE MA111	
D337	8-719-404-49	DIODE MA111	
D338	8-719-404-49	DIODE MA111	
D339	8-719-404-49	DIODE MA111	
D344	8-719-801-78	DIODE 1SS184	
D345	8-719-104-34	DIODE 1S2836	
D346	8-719-104-34	DIODE 1S2836	
D347	8-719-104-34	DIODE 1S2836	
D360	1-216-295-91	SHORT 0	
D361	1-216-295-91	SHORT 0	
D362	8-719-158-40	DIODE RD10SB1	
D363	8-719-158-40	DIODE RD10SB1	
D364	8-719-104-34	DIODE 1S2836	
D365	8-719-404-49	DIODE MA111	
D381	8-719-404-49	DIODE MA111	
D401	8-719-404-49	DIODE MA111	
D404	8-719-800-76	DIODE 1SS226	
D405	8-719-801-78	DIODE 1SS184	
D406	8-719-404-49	DIODE MA111	
D407	8-719-404-49	DIODE MA111	
D408	8-719-404-49	DIODE MA111	
D410	8-719-404-49	DIODE MA111	
D411	8-719-404-49	DIODE MA111	
D414	8-719-801-78	DIODE 1SS184	
D415	8-719-801-78	DIODE 1SS184	
D416	8-719-801-78	DIODE 1SS184	
D417	8-719-801-78	DIODE 1SS184	
D418	8-719-801-78	DIODE 1SS184	
D421	8-719-404-49	DIODE MA111	
D422	8-719-404-49	DIODE MA111	
D423	8-719-800-76	DIODE 1SS226	
D424	8-719-404-49	DIODE MA111	
D425	8-719-800-76	DIODE 1SS226	
D427	8-719-404-49	DIODE MA111	
D500	8-719-404-49	DIODE MA111	
D501	8-719-977-03	DIODE DTZ5.6B	
D502	8-719-979-80	DIODE UF5406	
D503	8-719-404-49	DIODE MA111	
D504	8-719-901-83	DIODE 1SS83	
D505	8-719-028-72	DIODE RGP02-17EL-6433	
D506	8-719-033-83	DIODE ERD07-15	
D507	8-719-800-76	DIODE 1SS226	
D508	8-719-800-76	DIODE 1SS226	
D510	8-719-302-43	DIODE EL1Z	
D512	8-719-979-80	DIODE UF5406	
D513	8-719-404-49	DIODE MA111	
D514	8-719-971-20	DIODE ERC38-06	
D515	8-719-971-20	DIODE ERC38-06	



REF. NO.	PART NO.	DESCRIPTION	REMARK	REF. NO.	PART NO.	DESCRIPTION	REMARK
D516	8-719-404-49	DIODE MA111		IC315	8-759-932-67	IC BU4053BCF	
D517	8-719-404-49	DIODE MA111		IC316	8-759-432-78	IC MM1111XFBE	
D518	8-719-404-49	DIODE MA111		IC317	8-759-009-51	IC MC14538BF	
D519	8-719-404-49	DIODE MA111		IC318	8-759-009-67	IC MC14584BF	
D520	8-719-801-78	DIODE 1SS184		IC319	8-759-008-67	IC MC14066BF	
D521	8-719-404-49	DIODE MA111		IC320	8-759-358-46	IC MM1114XFBE	
D522	8-719-977-05	DIODE DTZ6.2		IC321	8-759-446-66	IC MM1113XFBE	
D523	8-719-404-49	DIODE MA111		IC322	8-759-446-66	IC MM1113XFBE	
D524	8-719-200-02	DIODE 10E-2		IC323	8-759-446-66	IC MM1113XFBE	
D525	8-719-200-02	DIODE 10E-2		IC324	8-759-446-66	IC MM1113XFBE	
D526	8-719-404-49	DIODE MA111		IC325	8-759-446-66	IC MM1113XFBE	
D527	8-719-200-02	DIODE 10E-2		IC326	8-759-060-00	IC BA10324AF	
D528	8-719-300-76	DIODE RH-1A		IC327	8-759-008-67	IC MC14066BF	
D529	8-719-200-02	DIODE 10E-2		IC350	8-759-909-71	IC BA4558F	
D530	8-719-300-76	DIODE RH-1A		IC402	8-752-053-21	IC CXA1211M	
D531	8-719-977-32	DIODE DTZ11B		IC404	8-752-067-05	IC CXA1739S	
D532	8-719-800-76	DIODE 1SS226		IC405	8-759-932-67	IC BU4053BCF	
D533	8-719-302-43	DIODE EL1Z		IC407	8-759-008-67	IC MC14066BF	
D534	8-719-404-49	DIODE MA111		IC408	8-759-510-73	IC BA10393F-E2	
D535	8-719-404-49	DIODE MA111		IC409	8-759-060-00	IC BA10324AF	
D536	8-719-800-76	DIODE 1SS226		IC410	8-759-009-06	IC MC14052BF	
D538	8-719-800-76	DIODE 1SS226		IC411	8-759-008-92	IC MC14024BF	
D539	8-719-404-49	DIODE MA111		IC412	8-759-932-67	IC BU4053BCF	
D540	8-719-404-49	DIODE MA111		IC413	8-759-932-67	IC BU4053BCF	
D541	8-719-801-78	DIODE 1SS184		IC500	8-749-010-07	IC H8D7248	
D543	8-719-404-49	DIODE MA111		IC502	8-759-009-51	IC MC14538BF	
		<DELAY LINE>		IC503	8-759-009-51	IC MC14538BF	
DL300	1-415-633-11	DELAY LINE, Y		IC504	8-752-053-21	IC CXA1211M	
DL301	1-415-632-11	DELAY LINE, Y		IC505	8-759-088-08	IC uPC7812AHF	
DL401	1-409-547-11	DELAY LINE		IC506	8-759-009-51	IC MC14538BF	
		<FERRITE BEAD>		IC507	8-759-100-60	IC uPC1377C	
FB501	1-410-396-41	FERRITE	0.45UH	IC508	8-752-053-21	IC CXA1211M	
		<FILTER>		IC509	8-759-998-98	IC LM358D	
FL300	1-236-547-11	TRAP, LC		IC510	8-759-009-51	IC MC14538BF	
FL401	1-236-364-11	FILTER, BAND PASS		IC513	8-759-009-51	IC MC14538BF	
		<IC>				<CHIP CONDUCTOR>	
IC101	*8-759-478-14	IC uPD78P018FYCW-MD1		JR302	1-216-295-91	SHORT	0
IC102	8-759-354-28	IC ST24C02FM6TR		JR307	1-216-295-91	SHORT	0
IC103	8-759-008-48	IC MC74HC86F		JR310	1-216-295-91	SHORT	0
IC104	8-759-262-59	IC uPD6451AGT-632-E2				<COIL>	
IC105	8-759-196-70	IC M62358FP-E1		L101	1-408-609-41	INDUCTOR 33UH	
IC106	8-759-196-70	IC M62358FP-E1		L102	1-408-611-31	INDUCTOR 47UH	
IC107	8-759-196-70	IC M62358FP-E1		L104	1-408-619-31	INDUCTOR 220UH	
IC108	8-759-042-02	IC S-80743AL-A7-S		L105	1-410-482-31	INDUCTOR 100UH	
IC109	8-759-196-70	IC M62358FP-E1		L300	1-410-478-11	INDUCTOR 47UH	
IC110	8-759-196-70	IC M62358FP-E1		L305	1-410-196-11	INDUCTOR CHIP 2.2UH	
IC111	8-759-009-22	IC MC14094BF		L308	1-410-466-41	INDUCTOR 4.7UH	
IC112	8-759-354-27	IC ST24C01FM6TR		L309	1-410-470-11	INDUCTOR 10UH	
IC200	8-759-420-04	IC AN5265		L311	1-410-470-11	INDUCTOR 10UH	
IC302	8-759-998-98	IC LM358D		L312	1-412-011-31	INDUCTOR CHIP 27UH	
IC303	8-759-009-51	IC MC14538BF		L314	1-412-011-31	INDUCTOR CHIP 27UH	
IC304	8-759-932-67	IC BU4053BCF		L316	1-412-011-31	INDUCTOR CHIP 27UH	
IC305	8-759-631-08	IC M51279FP		L317	1-410-090-41	INDUCTOR 18mH	
IC306	8-759-358-46	IC MM1114XFBE		L319	1-408-615-31	INDUCTOR 100UH	
IC307	8-759-008-67	IC MC14066BF		L320	1-410-682-31	INDUCTOR 470UH	
IC309	8-759-358-46	IC MM1114XFBE		L401	1-410-478-11	INDUCTOR 47UH	
IC310	8-759-932-67	IC BU4053BCF		L402	1-410-216-31	INDUCTOR CHIP 100UH	
IC311	8-759-008-67	IC MC14066BF		L403	1-410-216-31	INDUCTOR CHIP 100UH	
IC312	8-759-358-46	IC MM1114XFBE		L404	1-410-216-31	INDUCTOR CHIP 100UH	
IC313	8-759-446-66	IC MM1113XFBE		L405	1-408-613-31	INDUCTOR 68UH	
IC314	8-759-446-66	IC MM1113XFBE		L406	1-408-613-31	INDUCTOR 68UH	
				L409	1-410-214-31	INDUCTOR CHIP 68UH	
				L500	1-459-155-00	COIL (WITH CORE) 45UH	
				L501	1-407-365-00	COIL,CHOKE	
				L502	1-407-365-00	COIL,CHOKE	

A

Les composants identifiés par une trame et une marque Δ sont critiques pour la sécurité. Ne les remplacer que par une pièce portant le numéro spécifié.

The components identified by shading and mark Δ are critical for safety. Replace only with part number specified.

REF. NO.	PART NO.	DESCRIPTION	REMARK
L503	1-410-093-11	INDUCTOR 33mH	
L504	1-410-666-31	INDUCTOR 18UH	
L505	1-410-671-31	INDUCTOR 47UH	
L507	1-410-686-11	INDUCTOR 1mH	
L508	1-412-530-31	INDUCTOR 27UH	
L509	1-459-075-11	COIL,DYNAMIC CONVERSION CHOKE	
L511	1-459-105-21	INDUCTOR 0UH	
L512	1-459-155-00	COIL (WITH CORE) 45UH	
L513	1-412-447-11	INDUCTOR 3.9mH	
L514	1-459-104-00	COIL, DUST CORE	
L515	1-459-059-00	COIL,DUST CORE	
L516	Δ 1-416-162-11	COIL, HORIZONTAL LINEARITY	
L517	1-412-547-21	INDUCTOR 680UH	
<NEON LAMP>			
NL500	1-519-526-11	LAMP, NEON	
<TRANSISTOR>			
Q101	1-801-806-11	TRANSISTOR DTC144EKA-T146	
Q104	8-729-907-26	TRANSISTOR IMX1	
Q105	8-729-027-38	TRANSISTOR DTA144EKA-T146	
Q107	8-729-027-38	TRANSISTOR DTA144EKA-T146	
Q108	8-729-422-29	TRANSISTOR 2SD601A-S	
Q110	8-729-422-29	TRANSISTOR 2SD601A-S	
Q112	8-729-422-29	TRANSISTOR 2SD601A-S	
Q113	8-729-422-29	TRANSISTOR 2SD601A-S	
Q114	8-729-422-29	TRANSISTOR 2SD601A-S	
Q200	8-729-140-96	TRANSISTOR 2SD774-34	
Q201	8-729-422-29	TRANSISTOR 2SD601A-S	
Q300	8-729-422-29	TRANSISTOR 2SD601A-S	
Q301	8-729-422-29	TRANSISTOR 2SD601A-S	
Q302	8-729-216-22	TRANSISTOR 2SA1162-G	
Q303	8-729-422-29	TRANSISTOR 2SD601A-S	
Q305	8-729-422-29	TRANSISTOR 2SD601A-S	
Q306	8-729-422-29	TRANSISTOR 2SD601A-S	
Q307	8-729-422-29	TRANSISTOR 2SD601A-S	
Q308	8-729-422-29	TRANSISTOR 2SD601A-S	
Q309	8-729-422-37	TRANSISTOR 2SB709A-R	
Q310	8-729-422-37	TRANSISTOR 2SB709A-R	
Q311	8-729-422-37	TRANSISTOR 2SB709A-R	
Q312	8-729-422-29	TRANSISTOR 2SD601A-S	
Q313	8-729-422-37	TRANSISTOR 2SB709A-R	
Q314	8-729-027-38	TRANSISTOR DTA144EKA-T146	
Q315	8-729-422-37	TRANSISTOR 2SB709A-R	
Q316	8-729-422-29	TRANSISTOR 2SD601A-S	
Q318	8-729-422-37	TRANSISTOR 2SB709A-R	
Q319	8-729-422-29	TRANSISTOR 2SD601A-S	
Q320	8-729-422-29	TRANSISTOR 2SD601A-S	
Q321	8-729-422-29	TRANSISTOR 2SD601A-S	
Q322	8-729-422-29	TRANSISTOR 2SD601A-S	
Q323	1-801-806-11	TRANSISTOR DTC144EKA-T146	
Q324	1-801-806-11	TRANSISTOR DTC144EKA-T146	
Q325	8-729-422-29	TRANSISTOR 2SD601A-S	
Q326	8-729-422-29	TRANSISTOR 2SD601A-S	
Q327	8-729-422-37	TRANSISTOR 2SB709A-R	
Q328	8-729-141-53	TRANSISTOR 2SK94-X2X3X4	
Q329	8-729-141-53	TRANSISTOR 2SK94-X2X3X4	
Q330	8-729-422-37	TRANSISTOR 2SB709A-R	
Q331	8-729-422-37	TRANSISTOR 2SB709A-R	
Q332	1-801-806-11	TRANSISTOR DTC144EKA-T146	
Q333	8-729-422-29	TRANSISTOR 2SD601A-S	
Q335	8-729-422-29	TRANSISTOR 2SD601A-S	
Q338	8-729-120-28	TRANSISTOR 2SC1623-L5L6	
Q339	8-729-422-37	TRANSISTOR 2SB709A-R	
Q341	8-729-920-39	TRANSISTOR IMT1US	
Q342	8-729-920-39	TRANSISTOR IMT1US	
Q343	8-729-920-39	TRANSISTOR IMT1US	

REF. NO.	PART NO.	DESCRIPTION	REMARK
Q345	8-729-422-29	TRANSISTOR 2SD601A-S	
Q350	8-729-422-37	TRANSISTOR 2SB709A-R	
Q351	8-729-422-29	TRANSISTOR 2SD601A-S	
Q352	8-729-422-29	TRANSISTOR 2SD601A-S	
Q353	8-729-422-29	TRANSISTOR 2SD601A-S	
Q354	8-729-422-29	TRANSISTOR 2SD601A-S	
Q355	8-729-422-29	TRANSISTOR 2SD601A-S	
Q356	1-801-806-11	TRANSISTOR DTC144EKA-T146	
Q360	8-729-907-26	TRANSISTOR IMX1	
Q361	8-729-027-38	TRANSISTOR DTA144EKA-T146	
Q362	8-729-422-29	TRANSISTOR 2SD601A-S	
Q363	8-729-422-29	TRANSISTOR 2SD601A-S	
Q364	1-801-806-11	TRANSISTOR DTC144EKA-T146	
Q365	1-801-806-11	TRANSISTOR DTC144EKA-T146	
Q366	8-729-422-37	TRANSISTOR 2SB709A-R	
Q367	8-729-422-37	TRANSISTOR 2SB709A-R	
Q368	8-729-422-37	TRANSISTOR 2SB709A-R	
Q369	8-729-027-38	TRANSISTOR DTA144EKA-T146	
Q372	1-801-806-11	TRANSISTOR DTC144EKA-T146	
Q380	1-801-806-11	TRANSISTOR DTC144EKA-T146	
Q381	1-801-806-11	TRANSISTOR DTC144EKA-T146	
Q382	1-801-806-11	TRANSISTOR DTC144EKA-T146	
Q383	1-801-806-11	TRANSISTOR DTC144EKA-T146	
Q384	1-801-806-11	TRANSISTOR DTC144EKA-T146	
Q385	1-801-806-11	TRANSISTOR DTC144EKA-T146	
Q386	1-801-806-11	TRANSISTOR DTC144EKA-T146	
Q401	8-729-422-29	TRANSISTOR 2SD601A-S	
Q402	8-729-422-29	TRANSISTOR 2SD601A-S	
Q407	8-729-422-29	TRANSISTOR 2SD601A-S	
Q409	8-729-422-37	TRANSISTOR 2SB709A-R	
Q410	8-729-907-26	TRANSISTOR IMX1	
Q412	8-729-216-22	TRANSISTOR 2SA1162-G	
Q414	8-729-422-37	TRANSISTOR 2SB709A-R	
Q415	8-729-422-37	TRANSISTOR 2SB709A-R	
Q416	8-729-422-37	TRANSISTOR 2SB709A-R	
Q417	8-729-422-37	TRANSISTOR 2SB709A-R	
Q418	8-729-120-28	TRANSISTOR 2SC1623-L5L6	
Q419	8-729-422-37	TRANSISTOR 2SB709A-R	
Q420	8-729-422-37	TRANSISTOR 2SB709A-R	
Q421	1-801-806-11	TRANSISTOR DTC144EKA-T146	
Q422	8-729-120-28	TRANSISTOR 2SC1623-L5L6	
Q423	8-729-422-29	TRANSISTOR 2SD601A-S	
Q424	1-801-806-11	TRANSISTOR DTC144EKA-T146	
Q425	1-801-806-11	TRANSISTOR DTC144EKA-T146	
Q426	1-801-806-11	TRANSISTOR DTC144EKA-T146	
Q428	8-729-422-37	TRANSISTOR 2SB709A-R	
Q429	8-729-422-37	TRANSISTOR 2SB709A-R	
Q430	8-729-422-29	TRANSISTOR 2SD601A-S	
Q431	8-729-422-29	TRANSISTOR 2SD601A-S	
Q432	8-729-422-29	TRANSISTOR 2SD601A-S	
Q433	1-801-806-11	TRANSISTOR DTC144EKA-T146	
Q434	8-729-422-29	TRANSISTOR 2SD601A-S	
Q435	1-801-806-11	TRANSISTOR DTC144EKA-T146	
Q436	1-801-806-11	TRANSISTOR DTC144EKA-T146	
Q437	1-801-806-11	TRANSISTOR DTC144EKA-T146	
Q442	8-729-422-29	TRANSISTOR 2SD601A-S	
Q443	8-729-216-22	TRANSISTOR 2SA1162-G	
Q444	8-729-422-29	TRANSISTOR 2SD601A-S	
Q445	1-801-806-11	TRANSISTOR DTC144EKA-T146	
Q446	1-801-806-11	TRANSISTOR DTC144EKA-T146	
Q447	1-801-806-11	TRANSISTOR DTC144EKA-T146	
Q448	1-801-806-11	TRANSISTOR DTC144EKA-T146	
Q449	1-801-806-11	TRANSISTOR DTC144EKA-T146	
Q500	8-729-422-37	TRANSISTOR 2SB709A-R	
Q501	8-729-821-87	TRANSISTOR 2SD1878-CA	
Q502	8-729-119-80	TRANSISTOR 2SC2688-LK	
Q503	8-729-033-29	TRANSISTOR 2SD1210(LK)-MT2	
Q505	8-729-422-29	TRANSISTOR 2SD601A-S	



REF. NO.	PART NO.	DESCRIPTION	REMARK	REF. NO.	PART NO.	DESCRIPTION	REMARK
Q506	8-729-422-29	TRANSISTOR 2SD601A-S		R200	1-216-686-11	METAL CHIP 30K	0.50% 1/10W
Q507	8-729-422-29	TRANSISTOR 2SD601A-S		R201	1-216-049-91	RES,CHIP 1K	5% 1/10W
Q508	8-729-422-37	TRANSISTOR 2SB709A-R		R202	1-212-857-00	FUSIBLE 10	5% 1/4W F
Q511	8-729-422-29	TRANSISTOR 2SD601A-S		R203	1-260-095-11	CARBON 470	5% 1/2W
Q512	8-729-195-82	TRANSISTOR 2SC2958-L		R204	1-260-072-11	CARBON 4.7	5% 1/2W
Q513	8-729-122-03	TRANSISTOR 2SA1220A-P		R205	1-216-647-11	METAL CHIP 680	0.50% 1/10W
Q514	8-729-901-00	TRANSISTOR DTC124EK		R206	1-216-073-00	RES,CHIP 10K	5% 1/10W
Q515	8-729-106-92	TRANSISTOR 2SC2690A-Q		R207	1-216-065-91	RES,CHIP 4.7K	5% 1/10W
Q516	1-801-806-11	TRANSISTOR DTC144EKA-T146		R208	1-216-065-91	RES,CHIP 4.7K	5% 1/10W
Q517	8-729-027-38	TRANSISTOR DTA144EKA-T146		R209	1-216-073-00	RES,CHIP 10K	5% 1/10W
Q518	1-801-806-11	TRANSISTOR DTC144EKA-T146		R210	1-216-061-00	RES,CHIP 3.3K	5% 1/10W
Q519	1-801-806-11	TRANSISTOR DTC144EKA-T146		R211	1-249-393-11	CARBON 10	5% 1/4W F
Q520	8-729-021-82	TRANSISTOR 2SD2396K		R302	1-216-025-91	RES,CHIP 100	5% 1/10W
Q522	8-729-422-29	TRANSISTOR 2SD601A-S		R304	1-216-025-91	RES,CHIP 100	5% 1/10W
Q523	8-729-422-29	TRANSISTOR 2SD601A-S		R307	1-216-115-00	RES,CHIP 560K	5% 1/10W
Q524	8-729-422-29	TRANSISTOR 2SD601A-S		R308	1-216-065-91	RES,CHIP 4.7K	5% 1/10W
Q525	8-729-422-37	TRANSISTOR 2SB709A-R		R311	1-216-055-00	RES,CHIP 1.8K	5% 1/10W
Q533	1-801-806-11	TRANSISTOR DTC144EKA-T146		R312	1-216-073-00	RES,CHIP 10K	5% 1/10W
Q534	8-729-422-29	TRANSISTOR 2SD601A-S		R313	1-216-648-11	METAL CHIP 750	0.50% 1/10W
Q535	8-729-422-29	TRANSISTOR 2SD601A-S		R314	1-216-099-00	RES,CHIP 120K	5% 1/10W
		<RESISTOR>		R315	1-216-099-00	RES,CHIP 120K	5% 1/10W
R101	1-216-025-91	RES,CHIP 100	5% 1/10W	R316	1-216-049-91	RES,CHIP 1K	5% 1/10W
R102	1-216-025-91	RES,CHIP 100	5% 1/10W	R317	1-216-057-00	RES,CHIP 2.2K	5% 1/10W
R103	1-216-025-91	RES,CHIP 100	5% 1/10W	R318	1-216-049-91	RES,CHIP 1K	5% 1/10W
R104	1-216-073-00	RES,CHIP 10K	5% 1/10W	R320	1-216-057-00	RES,CHIP 2.2K	5% 1/10W
R105	1-216-059-00	RES,CHIP 2.7K	5% 1/10W	R321	1-216-051-00	RES,CHIP 1.2K	5% 1/10W
R106	1-216-065-91	RES,CHIP 4.7K	5% 1/10W	R322	1-216-035-00	RES,CHIP 270	5% 1/10W
R107	1-216-065-91	RES,CHIP 4.7K	5% 1/10W	R323	1-216-109-00	RES,CHIP 330K	5% 1/10W
R108	1-216-065-91	RES,CHIP 4.7K	5% 1/10W	R324	1-216-101-00	RES,CHIP 150K	5% 1/10W
R109	1-216-065-91	RES,CHIP 4.7K	5% 1/10W	R325	1-216-037-00	RES,CHIP 330	5% 1/10W
R110	1-216-073-00	RES,CHIP 10K	5% 1/10W	R326	1-216-033-00	RES,CHIP 220	5% 1/10W
R113	1-216-085-00	RES,CHIP 33K	5% 1/10W	R328	1-216-121-91	RES,CHIP 1M	5% 1/10W
R117	1-216-073-00	RES,CHIP 10K	5% 1/10W	R329	1-216-055-00	RES,CHIP 1.8K	5% 1/10W
R119	1-216-073-00	RES,CHIP 10K	5% 1/10W	R330	1-216-089-91	RES,CHIP 47K	5% 1/10W
R130	1-216-099-00	RES,CHIP 120K	5% 1/10W	R331	1-216-093-00	RES,CHIP 68K	5% 1/10W
R132	1-216-065-91	RES,CHIP 4.7K	5% 1/10W	R332	1-216-097-91	RES,CHIP 100K	5% 1/10W
R134	1-216-065-91	RES,CHIP 4.7K	5% 1/10W	R333	1-216-097-91	RES,CHIP 100K	5% 1/10W
R137	1-216-065-91	RES,CHIP 4.7K	5% 1/10W	R334	1-216-093-00	RES,CHIP 68K	5% 1/10W
R140	1-216-033-00	RES,CHIP 220	5% 1/10W	R335	1-216-083-00	RES,CHIP 27K	5% 1/10W
R141	1-216-085-00	RES,CHIP 33K	5% 1/10W	R336	1-216-065-91	RES,CHIP 4.7K	5% 1/10W
R144	1-216-295-91	SHORT 0		R342	1-216-065-91	RES,CHIP 4.7K	5% 1/10W
R149	1-216-065-91	RES,CHIP 4.7K	5% 1/10W	R345	1-216-063-91	RES,CHIP 3.9K	5% 1/10W
R151	1-216-061-00	RES,CHIP 3.3K	5% 1/10W	R346	1-216-057-00	RES,CHIP 2.2K	5% 1/10W
R154	1-216-065-91	RES,CHIP 4.7K	5% 1/10W	R349	1-216-694-11	METAL CHIP 62K	0.50% 1/10W
R155	1-216-083-00	RES,CHIP 27K	5% 1/10W	R350	1-216-085-00	RES,CHIP 33K	5% 1/10W
R157	1-216-065-91	RES,CHIP 4.7K	5% 1/10W	R351	1-216-061-00	RES,CHIP 3.3K	5% 1/10W
R158	1-216-295-91	SHORT 0		R354	1-216-123-11	RES,CHIP 1.2M	5% 1/10W
R159	1-216-063-91	RES,CHIP 3.9K	5% 1/10W	R357	1-216-121-91	RES,CHIP 1M	5% 1/10W
R160	1-216-061-00	RES,CHIP 3.3K	5% 1/10W	R366	1-216-065-91	RES,CHIP 4.7K	5% 1/10W
R162	1-216-065-91	RES,CHIP 4.7K	5% 1/10W	R371	1-216-025-91	RES,CHIP 100	5% 1/10W
R163	1-216-065-91	RES,CHIP 4.7K	5% 1/10W	R372	1-216-073-00	RES,CHIP 10K	5% 1/10W
R164	1-216-067-00	RES,CHIP 5.6K	5% 1/10W	R373	1-216-645-11	METAL CHIP 560	0.50% 1/10W
R165	1-216-295-91	SHORT 0		R374	1-216-647-11	METAL CHIP 680	0.50% 1/10W
R167	1-216-061-00	RES,CHIP 3.3K	5% 1/10W	R375	1-216-073-00	RES,CHIP 10K	5% 1/10W
R168	1-216-085-00	RES,CHIP 33K	5% 1/10W	R376	1-216-111-91	RES,CHIP 390K	5% 1/10W
R169	1-216-107-00	RES,CHIP 270K	5% 1/10W	R378	1-216-114-00	RES,CHIP 510K	5% 1/10W
R171	1-216-031-00	RES,CHIP 180	5% 1/10W	R379	1-216-067-00	RES,CHIP 5.6K	5% 1/10W
R172	1-216-295-91	SHORT 0		R380	1-216-065-91	RES,CHIP 4.7K	5% 1/10W
R177	1-216-214-00	RES,CHIP 4.7K	5% 1/8W	R381	1-216-689-11	RES,CHIP 39K	5% 1/10W
R181	1-216-065-91	RES,CHIP 4.7K	5% 1/10W	R382	1-216-101-00	RES,CHIP 150K	5% 1/10W
R184	1-216-649-11	METAL CHIP 820	0.50% 1/10W	R386	1-216-091-00	RES,CHIP 56K	5% 1/10W
R185	1-216-073-00	RES,CHIP 10K	5% 1/10W	R387	1-216-029-00	RES,CHIP 150	5% 1/10W
R189	1-216-073-00	RES,CHIP 10K	5% 1/10W	R388	1-216-039-00	RES,CHIP 390	5% 1/10W
R190	1-216-049-91	RES,CHIP 1K	5% 1/10W	R389	1-216-649-11	METAL CHIP 820	0.50% 1/10W
R192	1-216-073-00	RES,CHIP 10K	5% 1/10W	R390	1-249-393-11	CARBON 10	5% 1/4W F
R195	1-216-071-00	RES,CHIP 8.2K	5% 1/10W	R393	1-216-073-00	RES,CHIP 10K	5% 1/10W
				R394	1-216-083-00	RES,CHIP 27K	5% 1/10W
				R395	1-216-651-11	METAL CHIP 1K	0.50% 1/10W
				R397	1-216-113-00	RES,CHIP 470K	5% 1/10W

A

REF. NO.	PART NO.	DESCRIPTION	REMARK
R398	1-216-105-91	RES,CHIP	220K 5% 1/10W
R399	1-216-111-91	RES,CHIP	390K 5% 1/10W
R400	1-216-113-00	RES,CHIP	470K 5% 1/10W
R404	1-216-029-00	RES,CHIP	150 5% 1/10W
R406	1-216-083-00	RES,CHIP	27K 5% 1/10W
R407	1-216-077-00	RES,CHIP	15K 5% 1/10W
R408	1-216-689-11	METAL CHIP	39K 0.50% 1/10W
R410	1-216-069-00	RES,CHIP	6.8K 5% 1/10W
R411	1-216-033-00	RES,CHIP	220 5% 1/10W
R413	1-216-668-11	METAL CHIP	5.1K 0.50% 1/10W
R414	1-216-673-11	METAL CHIP	8.2K 0.50% 1/10W
R416	1-216-113-00	RES,CHIP	470K 5% 1/10W
R417	1-216-665-11	METAL CHIP	3.9K 0.50% 1/10W
R418	1-216-667-11	METAL CHIP	4.7K 0.50% 1/10W
R419	1-216-065-91	RES,CHIP	4.7K 5% 1/10W
R420	1-216-687-11	METAL CHIP	33K 0.50% 1/10W
R426	1-216-039-00	RES,CHIP	390 5% 1/10W
R428	1-216-097-91	RES,CHIP	100K 5% 1/10W
R429	1-216-073-00	RES,CHIP	10K 5% 1/10W
R430	1-216-119-00	RES,CHIP	820K 5% 1/10W
R431	1-216-097-91	RES,CHIP	100K 5% 1/10W
R434	1-216-109-00	RES,CHIP	330K 5% 1/10W
R435	1-216-105-91	RES,CHIP	220K 5% 1/10W
R436	1-216-113-00	RES,CHIP	470K 5% 1/10W
R437	1-216-097-91	RES,CHIP	100K 5% 1/10W
R441	1-216-645-11	METAL CHIP	560 0.50% 1/10W
R442	1-216-647-11	METAL CHIP	680 0.50% 1/10W
R443	1-216-049-91	RES,CHIP	1K 5% 1/10W
R444	1-216-105-91	RES,CHIP	220K 5% 1/10W
R445	1-216-095-00	RES,CHIP	82K 5% 1/10W
R447	1-216-069-00	RES,CHIP	6.8K 5% 1/10W
R449	1-216-073-00	RES,CHIP	10K 5% 1/10W
R451	1-216-037-00	RES,CHIP	330 5% 1/10W
R452	1-216-651-11	METAL CHIP	1K 0.50% 1/10W
R453	1-216-097-91	RES,CHIP	100K 5% 1/10W
R459	1-216-649-11	METAL CHIP	820 0.50% 1/10W
R460	1-216-295-91	SHORT	0
R462	1-216-651-11	METAL CHIP	1K 0.50% 1/10W
R463	1-216-065-91	RES,CHIP	4.7K 5% 1/10W
R464	1-216-065-91	RES,CHIP	4.7K 5% 1/10W
R465	1-216-025-91	RES,CHIP	100 5% 1/10W
R466	1-216-077-00	RES,CHIP	15K 5% 1/10W
R468	1-216-105-91	RES,CHIP	220K 5% 1/10W
R469	1-216-063-91	RES,CHIP	3.9K 5% 1/10W
R471	1-216-109-00	RES,CHIP	330K 5% 1/10W
R472	1-216-077-00	RES,CHIP	15K 5% 1/10W
R473	1-216-121-91	RES,CHIP	1M 5% 1/10W
R476	1-216-061-00	RES,CHIP	3.3K 5% 1/10W
R477	1-216-061-00	RES,CHIP	3.3K 5% 1/10W
R478	1-216-073-00	RES,CHIP	10K 5% 1/10W
R479	1-216-085-00	RES,CHIP	33K 5% 1/10W
R482	1-216-057-00	RES,CHIP	2.2K 5% 1/10W
R483	1-216-025-91	RES,CHIP	100 5% 1/10W
R484	1-216-651-11	METAL CHIP	1K 0.50% 1/10W
R485	1-216-033-00	RES,CHIP	220 5% 1/10W
R486	1-216-681-11	METAL CHIP	18K 0.50% 1/10W
R487	1-216-653-11	METAL CHIP	1.2K 0.50% 1/10W
R488	1-216-073-00	RES,CHIP	10K 5% 1/10W
R489	1-216-077-00	RES,CHIP	15K 5% 1/10W
R491	1-216-061-00	RES,CHIP	3.3K 5% 1/10W
R492	1-216-085-00	RES,CHIP	33K 5% 1/10W
R493	1-216-295-91	SHORT	0
R494	1-216-696-11	METAL CHIP	75K 0.50% 1/10W
R495	1-216-651-11	METAL CHIP	1K 0.50% 1/10W
R496	1-216-073-00	RES,CHIP	10K 5% 1/10W
R497	1-216-653-11	METAL CHIP	1.2K 0.50% 1/10W
R498	1-216-061-00	RES,CHIP	3.3K 5% 1/10W
R499	1-216-033-00	RES,CHIP	220 5% 1/10W

REF. NO.	PART NO.	DESCRIPTION	REMARK
R500	1-216-689-11	RES,CHIP	39K 5% 1/10W
R501	1-216-077-00	RES,CHIP	15K 5% 1/10W
R502	1-216-677-11	METAL CHIP	12K 0.50% 1/10W
R503	1-216-677-11	METAL CHIP	12K 0.50% 1/10W
R504	1-216-111-91	RES,CHIP	390K 5% 1/10W
R505	1-216-067-00	RES,CHIP	5.6K 5% 1/10W
R506	1-216-073-00	RES,CHIP	10K 5% 1/10W
R507	1-216-083-00	RES,CHIP	27K 5% 1/10W
R508	1-216-105-91	RES,CHIP	220K 5% 1/10W
R509	1-216-089-91	RES,CHIP	47K 5% 1/10W
R510	1-216-097-91	RES,CHIP	100K 5% 1/10W
R511	1-216-099-00	RES,CHIP	120K 5% 1/10W
R512	1-216-055-00	RES,CHIP	1.8K 5% 1/10W
R513	1-216-295-91	SHORT	0
R514	1-216-295-91	SHORT	0
R515	1-216-675-11	METAL CHIP	10K 0.50% 1/10W
R516	1-216-103-00	RES,CHIP	180K 5% 1/10W
R517	1-214-888-00	METAL	10K 1% 1/2W
R518	1-260-123-11	CARBON	100K 5% 1/2W
R519	1-216-017-91	RES,CHIP	47 5% 1/10W
R520	1-249-423-11	CARBON	3.3K 5% 1/4W F
R521	1-216-065-91	RES,CHIP	4.7K 5% 1/10W
R523	1-215-892-11	METAL OXIDE	1K 5% 2W F
R524	1-216-093-00	RES,CHIP	68K 5% 1/10W
R525	1-216-069-00	RES,CHIP	6.8K 5% 1/10W
R526	1-216-089-91	RES,CHIP	47K 5% 1/10W
R527	1-216-089-91	RES,CHIP	47K 5% 1/10W
R528	1-216-089-91	RES,CHIP	47K 5% 1/10W
R529	1-216-089-91	RES,CHIP	47K 5% 1/10W
R530	1-216-367-11	METAL OXIDE	0.68 5% 2W F
R531	1-216-077-00	RES,CHIP	15K 5% 1/10W
R532	1-215-920-11	METAL OXIDE	3.3K 5% 3W F
R533	1-247-723-11	CARBON	6.8K 5% 1/4W F
R534	1-216-085-00	RES,CHIP	33K 5% 1/10W
R535	1-249-448-11	CARBON	1.2 5% 1/4W F
R536	1-216-101-00	RES,CHIP	150K 5% 1/10W
R537	1-216-089-91	RES,CHIP	47K 5% 1/10W
R539	1-216-065-91	RES,CHIP	4.7K 5% 1/10W
R540	1-216-113-00	RES,CHIP	470K 5% 1/10W
R541	1-249-383-11	CARBON	1.5 5% 1/4W F
R542	1-216-057-00	RES,CHIP	2.2K 5% 1/10W
R543	1-212-883-00	FUSIBLE	120 5% 1/4W F
R544	1-216-095-00	RES,CHIP	82K 5% 1/10W
R545	1-216-073-00	RES,CHIP	10K 5% 1/10W
R546	1-249-425-11	CARBON	4.7K 5% 1/4W F
R547	1-216-091-00	RES,CHIP	56K 5% 1/10W
R548	1-216-057-00	RES,CHIP	2.2K 5% 1/10W
R549	1-216-677-11	METAL CHIP	12K 0.50% 1/10W
R550	1-216-053-00	RES,CHIP	1.5K 5% 1/10W
R551	1-216-077-00	RES,CHIP	15K 5% 1/10W
R552	1-216-033-00	RES,CHIP	220 5% 1/10W
R553	1-216-083-00	RES,CHIP	27K 5% 1/10W
R554	1-216-095-00	RES,CHIP	82K 5% 1/10W
R555	1-216-692-11	METAL CHIP	51K 0.50% 1/10W
R556	1-215-897-11	METAL OXIDE	6.8K 5% 2W F
R557	1-216-462-00	METAL OXIDE	8.2K 5% 2W F
R558	1-215-891-11	METAL OXIDE	680 5% 2W F
R559	1-216-105-91	RES,CHIP	220K 5% 1/10W
R560	1-216-091-00	RES,CHIP	56K 5% 1/10W
R561	1-216-049-91	RES,CHIP	1K 5% 1/10W
R563	1-216-017-91	RES,CHIP	47 5% 1/10W
R564	1-216-107-00	RES,CHIP	270K 5% 1/10W
R565	1-216-033-00	RES,CHIP	220 5% 1/10W
R566	1-216-685-11	METAL CHIP	27K 0.50% 1/10W
R567	1-216-081-00	RES,CHIP	22K 5% 1/10W
R568	1-216-073-00	RES,CHIP	10K 5% 1/10W
R569	1-260-114-11	CARBON	18K 5% 1/2W
R571	1-216-065-91	RES,CHIP	4.7K 5% 1/10W



REF. NO.	PART NO.	DESCRIPTION	REMARK	REF. NO.	PART NO.	DESCRIPTION	REMARK
R572	1-216-059-00	RES,CHIP	2.7K 5% 1/10W	R1188	1-216-131-11	RES,CHIP	2.7M 5% 1/10W
R573	1-216-071-00	RES,CHIP	8.2K 5% 1/10W	R1189	1-216-071-00	RES,CHIP	8.2K 5% 1/10W
R575	1-249-383-11	CARBON	1.5 5% 1/4W F	R1190	1-216-131-11	RES,CHIP	2.7M 5% 1/10W
R576	1-216-101-00	RES,CHIP	150K 5% 1/10W	R1191	1-216-071-00	RES,CHIP	8.2K 5% 1/10W
R578	1-216-693-11	METAL CHIP	56K 0.50% 1/10W	R1192	1-216-131-11	RES,CHIP	2.7M 5% 1/10W
R579	1-216-081-00	RES,CHIP	22K 5% 1/10W	R1193	1-216-025-91	RES,CHIP	100 5% 1/10W
R580	1-216-105-91	RES,CHIP	220K 5% 1/10W	R1194	1-216-085-00	RES,CHIP	33K 5% 1/10W
R582	1-216-085-00	RES,CHIP	33K 5% 1/10W	R1195	1-216-025-91	RES,CHIP	100 5% 1/10W
R583	1-216-039-00	RES,CHIP	390 5% 1/10W	R1196	1-216-085-00	RES,CHIP	33K 5% 1/10W
R584	1-216-071-00	RES,CHIP	8.2K 5% 1/10W	R1197	1-216-025-91	RES,CHIP	100 5% 1/10W
R585	1-216-033-00	RES,CHIP	220 5% 1/10W	R1198	1-216-085-00	RES,CHIP	33K 5% 1/10W
R586	1-216-686-11	METAL CHIP	30K 0.50% 1/10W	R1303	1-216-073-00	RES,CHIP	10K 5% 1/10W
R587	1-216-675-11	METAL CHIP	10K 0.50% 1/10W	R1304	1-216-689-11	RES,CHIP	39K 5% 1/10W
R588	1-216-077-00	RES,CHIP	15K 5% 1/10W	R1305	1-216-033-00	RES,CHIP	220 5% 1/10W
R589	1-216-067-00	RES,CHIP	5.6K 5% 1/10W	R1306	1-216-645-11	METAL CHIP	560 0.50% 1/10W
R590	1-216-081-00	RES,CHIP	22K 5% 1/10W	R1307	1-216-091-00	RES,CHIP	56K 5% 1/10W
R591	1-216-682-11	METAL CHIP	20K 0.50% 1/10W	R1308	1-216-645-11	METAL CHIP	560 0.50% 1/10W
R592	1-247-688-11	CARBON	10 5% 1/4W F	R1309	1-216-025-91	RES,CHIP	100 5% 1/10W
R593	1-216-647-11	METAL CHIP	680 0.50% 1/10W	R1310	1-216-057-00	RES,CHIP	2.2K 5% 1/10W
R594	1-247-713-11	CARBON	1K 5% 1/4W	R1311	1-216-089-91	RES,CHIP	47K 5% 1/10W
R595	1-216-689-11	RES,CHIP	39K 5% 1/10W	R1312	1-216-027-00	RES,CHIP	120 5% 1/10W
R596	1-214-754-00	METAL	11K 1% 1/4W	R1313	1-216-097-91	RES,CHIP	100K 5% 1/10W
R597	1-249-417-11	CARBON	1K 5% 1/4W F	R1314	1-216-081-00	RES,CHIP	22K 5% 1/10W
R598	1-216-085-00	RES,CHIP	33K 5% 1/10W	R1315	1-216-073-00	RES,CHIP	10K 5% 1/10W
R599	1-216-645-11	METAL CHIP	560 0.50% 1/10W	R1316	1-216-065-91	RES,CHIP	4.7K 5% 1/10W
R1103	1-216-077-00	RES,CHIP	15K 5% 1/10W	R1317	1-216-033-00	RES,CHIP	220 5% 1/10W
R1104	1-216-699-11	METAL CHIP	100K 0.50% 1/10W	R1318	1-216-089-91	RES,CHIP	47K 5% 1/10W
R1105	1-216-073-00	RES,CHIP	10K 5% 1/10W	R1319	1-216-085-00	RES,CHIP	33K 5% 1/10W
R1106	1-216-097-91	RES,CHIP	100K 5% 1/10W	R1320	1-216-057-00	RES,CHIP	2.2K 5% 1/10W
R1107	1-216-059-00	RES,CHIP	2.7K 5% 1/10W	R1321	1-216-649-11	METAL CHIP	820 0.50% 1/10W
R1108	1-216-681-11	METAL CHIP	18K 0.50% 1/10W	R1322	1-216-057-00	RES,CHIP	2.2K 5% 1/10W
R1113	1-216-081-00	RES,CHIP	22K 5% 1/10W	R1324	1-216-061-00	RES,CHIP	3.3K 5% 1/10W
R1123	1-216-071-00	RES,CHIP	8.2K 5% 1/10W	R1325	1-216-652-11	METAL CHIP	1.1K 0.50% 1/10W
R1125	1-216-049-91	RES,CHIP	1K 5% 1/10W	R1326	1-216-073-00	RES,CHIP	10K 5% 1/10W
R1126	1-216-041-00	RES,CHIP	470 5% 1/10W	R1327	1-216-073-00	RES,CHIP	10K 5% 1/10W
R1128	1-216-065-91	RES,CHIP	4.7K 5% 1/10W	R1328	1-216-125-00	RES,CHIP	1.5M 5% 1/10W
R1129	1-216-071-00	RES,CHIP	8.2K 5% 1/10W	R1329	1-216-103-00	RES,CHIP	180K 5% 1/10W
R1130	1-216-049-91	RES,CHIP	1K 5% 1/10W	R1330	1-216-081-00	RES,CHIP	22K 5% 1/10W
R1131	1-216-049-91	RES,CHIP	1K 5% 1/10W	R1331	1-216-679-11	METAL CHIP	15K 0.50% 1/10W
R1132	1-216-071-00	RES,CHIP	8.2K 5% 1/10W	R1332	1-216-671-11	METAL CHIP	6.8K 0.50% 1/10W
R1133	1-216-069-00	RES,CHIP	6.8K 5% 1/10W	R1333	1-216-049-91	RES,CHIP	1K 5% 1/10W
R1134	1-216-073-00	RES,CHIP	10K 5% 1/10W	R1334	1-216-063-91	RES,CHIP	3.9K 5% 1/10W
R1136	1-216-097-91	RES,CHIP	100K 5% 1/10W	R1335	1-249-401-11	CARBON	47 5% 1/4W F
R1139	1-216-055-00	RES,CHIP	1.8K 5% 1/10W	R1336	1-216-095-00	RES,CHIP	82K 5% 1/10W
R1140	1-216-653-11	METAL CHIP	1.2K 0.50% 1/10W	R1337	1-216-061-00	RES,CHIP	3.3K 5% 1/10W
R1141	1-216-073-00	RES,CHIP	10K 5% 1/10W	R1338	1-216-647-11	METAL CHIP	680 0.50% 1/10W
R1142	1-216-653-11	METAL CHIP	1.2K 0.50% 1/10W	R1339	1-216-033-00	RES,CHIP	220 5% 1/10W
R1143	1-216-653-11	METAL CHIP	1.2K 0.50% 1/10W	R1340	1-216-033-00	RES,CHIP	220 5% 1/10W
R1146	1-216-057-00	RES,CHIP	2.2K 5% 1/10W	R1341	1-216-033-00	RES,CHIP	220 5% 1/10W
R1147	1-216-057-00	RES,CHIP	2.2K 5% 1/10W	R1342	1-216-083-00	RES,CHIP	27K 5% 1/10W
R1150	1-216-037-00	RES,CHIP	330 5% 1/10W	R1343	1-216-037-00	RES,CHIP	330 5% 1/10W
R1151	1-216-081-00	RES,CHIP	22K 5% 1/10W	R1344	1-216-093-00	RES,CHIP	68K 5% 1/10W
R1155	1-216-133-00	RES,CHIP	3.3M 5% 1/10W	R1345	1-216-109-00	RES,CHIP	330K 5% 1/10W
R1163	1-216-033-00	RES,CHIP	220 5% 1/10W	R1346	1-216-097-91	RES,CHIP	100K 5% 1/10W
R1164	1-216-049-91	RES,CHIP	1K 5% 1/10W	R1347	1-216-073-00	RES,CHIP	10K 5% 1/10W
R1165	1-216-049-91	RES,CHIP	1K 5% 1/10W	R1348	1-216-071-00	RES,CHIP	8.2K 5% 1/10W
R1170	1-216-089-91	RES,CHIP	47K 5% 1/10W	R1349	1-216-035-00	RES,CHIP	270 5% 1/10W
R1171	1-216-085-00	RES,CHIP	33K 5% 1/10W	R1350	1-216-073-00	RES,CHIP	10K 5% 1/10W
R1172	1-216-085-00	RES,CHIP	33K 5% 1/10W	R1351	1-216-033-00	RES,CHIP	220 5% 1/10W
R1174	1-216-089-91	RES,CHIP	47K 5% 1/10W	R1352	1-216-025-91	RES,CHIP	100 5% 1/10W
R1177	1-216-071-00	RES,CHIP	8.2K 5% 1/10W	R1353	1-216-065-91	RES,CHIP	4.7K 5% 1/10W
R1179	1-216-041-00	RES,CHIP	470 5% 1/10W	R1354	1-216-089-91	RES,CHIP	47K 5% 1/10W
R1180	1-216-089-91	RES,CHIP	47K 5% 1/10W	R1355	1-216-033-00	RES,CHIP	220 5% 1/10W
R1182	1-216-131-11	RES,CHIP	2.7M 5% 1/10W	R1356	1-216-105-91	RES,CHIP	220K 5% 1/10W
R1183	1-216-071-00	RES,CHIP	8.2K 5% 1/10W	R1357	1-216-101-00	RES,CHIP	150K 5% 1/10W
R1184	1-216-131-11	RES,CHIP	2.7M 5% 1/10W	R1358	1-216-071-00	RES,CHIP	8.2K 5% 1/10W
R1185	1-216-071-00	RES,CHIP	8.2K 5% 1/10W	R1359	1-216-099-00	RES,CHIP	120K 5% 1/10W
R1186	1-216-131-11	RES,CHIP	2.7M 5% 1/10W	R1360	1-216-065-91	RES,CHIP	4.7K 5% 1/10W
R1187	1-216-071-00	RES,CHIP	8.2K 5% 1/10W				



REF. NO.	PART NO.	DESCRIPTION	REMARK	REF. NO.	PART NO.	DESCRIPTION	REMARK		
R1361	1-216-113-00	RES,CHIP	470K 5%	1/10W	R1432	1-216-089-91	RES,CHIP 47K 5%	1/10W	
R1362	1-216-676-11	METAL CHIP	11K 0.50%	1/10W	R1433	1-216-085-00	RES,CHIP	33K 5%	1/10W
R1363	1-216-113-00	RES,CHIP	470K 5%	1/10W	R1434	1-216-645-11	METAL CHIP	560 0.50%	1/10W
R1364	1-216-073-00	RES,CHIP	10K 5%	1/10W	R1435	1-216-055-00	RES,CHIP	1.8K 5%	1/10W
R1365	1-216-131-11	RES,CHIP	2.7M 5%	1/10W	R1436	1-216-073-00	RES,CHIP	10K 5%	1/10W
R1366	1-216-081-00	RES,CHIP	22K 5%	1/10W	R1437	1-216-069-00	RES,CHIP	6.8K 5%	1/10W
R1367	1-216-660-11	METAL CHIP	2.4K 0.50%	1/10W	R1438	1-216-073-00	RES,CHIP	10K 5%	1/10W
R1368	1-216-059-00	RES,CHIP	2.7K 5%	1/10W	R1439	1-216-059-00	RES,CHIP	2.7K 5%	1/10W
R1369	1-216-051-00	RES,CHIP	1.2K 5%	1/10W	R1440	1-216-041-00	RES,CHIP	470 5%	1/10W
R1370	1-216-105-91	RES,CHIP	220K 5%	1/10W	R1441	1-216-033-00	RES,CHIP	220 5%	1/10W
R1371	1-216-113-00	RES,CHIP	470K 5%	1/10W	R1442	1-216-073-00	RES,CHIP	10K 5%	1/10W
R1372	1-216-089-91	RES,CHIP	47K 5%	1/10W	R1443	1-216-013-00	RES,CHIP	33 5%	1/10W
R1373	1-216-063-91	RES,CHIP	3.9K 5%	1/10W	R1444	1-216-057-00	RES,CHIP	2.2K 5%	1/10W
R1374	1-216-101-00	RES,CHIP	150K 5%	1/10W	R1445	1-216-071-00	RES,CHIP	8.2K 5%	1/10W
R1375	1-216-645-11	METAL CHIP	560 0.50%	1/10W	R1446	1-216-071-00	RES,CHIP	8.2K 5%	1/10W
R1376	1-216-647-11	METAL CHIP	680 0.50%	1/10W	R1447	1-216-081-00	RES,CHIP	22K 5%	1/10W
R1378	1-216-065-91	RES,CHIP	4.7K 5%	1/10W	R1448	1-216-085-00	RES,CHIP	33K 5%	1/10W
R1379	1-216-037-00	RES,CHIP	330 5%	1/10W	R1449	1-216-057-00	RES,CHIP	2.2K 5%	1/10W
R1380	1-216-645-11	METAL CHIP	560 0.50%	1/10W	R1450	1-216-129-00	RES,CHIP	2.2M 5%	1/10W
R1381	1-216-647-11	METAL CHIP	680 0.50%	1/10W	R1451	1-216-093-00	RES,CHIP	68K 5%	1/10W
R1382	1-216-073-00	RES,CHIP	10K 5%	1/10W	R1452	1-216-085-00	RES,CHIP	33K 5%	1/10W
R1383	1-216-681-11	METAL CHIP	18K 0.50%	1/10W	R1453	1-216-013-00	RES,CHIP	33 5%	1/10W
R1384	1-216-091-00	RES,CHIP	56K 5%	1/10W	R1454	1-216-065-91	RES,CHIP	4.7K 5%	1/10W
R1385	1-216-073-00	RES,CHIP	10K 5%	1/10W	R1455	1-216-113-00	RES,CHIP	470K 5%	1/10W
R1386	1-216-077-00	RES,CHIP	15K 5%	1/10W	R1456	1-216-129-00	RES,CHIP	2.2M 5%	1/10W
R1387	1-216-653-11	METAL CHIP	1.2K 0.50%	1/10W	R1457	1-216-089-91	RES,CHIP	47K 5%	1/10W
R1388	1-216-689-11	METAL CHIP	39K 0.50%	1/10W	R1458	1-216-085-00	RES,CHIP	33K 5%	1/10W
R1389	1-216-657-11	METAL CHIP	1.8K 0.50%	1/10W	R1459	1-216-133-00	RES,CHIP	3.3M 5%	1/10W
R1390	1-216-647-11	METAL CHIP	680 0.50%	1/10W	R1460	1-216-097-91	RES,CHIP	100K 5%	1/10W
R1391	1-216-025-91	RES,CHIP	100 5%	1/10W	R1461	1-216-645-11	METAL CHIP	560 0.50%	1/10W
R1392	1-216-041-00	RES,CHIP	470 5%	1/10W	R1462	1-216-645-11	METAL CHIP	560 0.50%	1/10W
R1393	1-216-063-91	RES,CHIP	3.9K 5%	1/10W	R1463	1-216-645-11	METAL CHIP	560 0.50%	1/10W
R1394	1-216-041-00	RES,CHIP	470 5%	1/10W	R1464	1-216-057-00	RES,CHIP	2.2K 5%	1/10W
R1395	1-216-071-00	RES,CHIP	8.2K 5%	1/10W	R1465	1-216-097-91	RES,CHIP	100K 5%	1/10W
R1396	1-216-071-00	RES,CHIP	8.2K 5%	1/10W	R1466	1-216-055-00	RES,CHIP	1.8K 5%	1/10W
R1397	1-216-065-91	RES,CHIP	4.7K 5%	1/10W	R1467	1-216-073-00	RES,CHIP	10K 5%	1/10W
R1399	1-216-073-00	RES,CHIP	10K 5%	1/10W	R1468	1-216-091-00	RES,CHIP	56K 5%	1/10W
R1401	1-216-085-00	RES,CHIP	33K 5%	1/10W	R1469	1-216-057-00	RES,CHIP	2.2K 5%	1/10W
R1402	1-216-295-91	SHORT	0		R1470	1-216-057-00	RES,CHIP	2.2K 5%	1/10W
R1403	1-216-651-11	METAL CHIP	1K 0.50%	1/10W	R1471	1-216-049-91	RES,CHIP	1K 5%	1/10W
R1404	1-216-681-11	METAL CHIP	18K 0.50%	1/10W	R1472	1-216-085-00	RES,CHIP	33K 5%	1/10W
R1405	1-216-071-00	RES,CHIP	8.2K 5%	1/10W	R1473	1-216-081-00	RES,CHIP	22K 5%	1/10W
R1406	1-216-653-11	METAL CHIP	1.2K 0.50%	1/10W	R1475	1-216-677-11	METAL CHIP	12K 0.50%	1/10W
R1407	1-216-061-00	RES,CHIP	3.3K 5%	1/10W	R1476	1-216-063-91	RES,CHIP	3.9K 5%	1/10W
R1408	1-216-113-00	RES,CHIP	470K 5%	1/10W	R1477	1-216-057-00	RES,CHIP	2.2K 5%	1/10W
R1409	1-216-295-91	SHORT	0		R1478	1-216-061-00	RES,CHIP	3.3K 5%	1/10W
R1410	1-216-053-00	RES,CHIP	1.5K 5%	1/10W	R1480	1-216-089-91	RES,CHIP	47K 5%	1/10W
R1411	1-216-073-00	RES,CHIP	10K 5%	1/10W	R1481	1-216-115-00	RES,CHIP	560K 5%	1/10W
R1412	1-216-107-00	RES,CHIP	270K 5%	1/10W	R1482	1-216-089-91	RES,CHIP	47K 5%	1/10W
R1413	1-216-081-00	RES,CHIP	22K 5%	1/10W	R1483	1-216-089-91	RES,CHIP	47K 5%	1/10W
R1414	1-216-057-00	RES,CHIP	2.2K 5%	1/10W	R1484	1-216-081-00	RES,CHIP	22K 5%	1/10W
R1415	1-216-093-00	RES,CHIP	68K 5%	1/10W	R1485	1-216-113-00	RES,CHIP	470K 5%	1/10W
R1416	1-216-113-00	RES,CHIP	470K 5%	1/10W	R1486	1-216-097-91	RES,CHIP	100K 5%	1/10W
R1417	1-216-033-00	RES,CHIP	220 5%	1/10W	R1487	1-216-097-91	RES,CHIP	100K 5%	1/10W
R1418	1-216-033-00	RES,CHIP	220 5%	1/10W	R1488	1-216-083-00	RES,CHIP	27K 5%	1/10W
R1419	1-216-025-91	RES,CHIP	100 5%	1/10W	R1490	1-216-035-00	RES,CHIP	270 5%	1/10W
R1420	1-216-089-91	RES,CHIP	47K 5%	1/10W	R1491	1-216-035-00	RES,CHIP	270 5%	1/10W
R1421	1-216-649-11	METAL CHIP	820 0.50%	1/10W	R1492	1-216-035-00	RES,CHIP	270 5%	1/10W
R1422	1-216-085-00	RES,CHIP	33K 5%	1/10W	R1493	1-216-083-00	RES,CHIP	27K 5%	1/10W
R1423	1-216-057-00	RES,CHIP	2.2K 5%	1/10W	R1494	1-216-081-00	RES,CHIP	22K 5%	1/10W
R1424	1-216-081-00	RES,CHIP	22K 5%	1/10W	R1495	1-216-089-91	RES,CHIP	47K 5%	1/10W
R1425	1-216-013-00	RES,CHIP	33 5%	1/10W	R1496	1-216-089-91	RES,CHIP	47K 5%	1/10W
R1426	1-216-113-00	RES,CHIP	470K 5%	1/10W	R1498	1-216-065-91	RES,CHIP	4.7K 5%	1/10W
R1427	1-216-681-11	METAL CHIP	18K 0.50%	1/10W	R1500	1-216-647-11	METAL CHIP	680 0.50%	1/10W
R1428	1-216-061-00	RES,CHIP	3.3K 5%	1/10W	R1501	1-216-075-00	RES,CHIP	12K 5%	1/10W
R1429	1-216-668-11	METAL CHIP	5.1K 0.50%	1/10W	R1502	1-260-111-11	CARBON	10K 5%	1/2W
R1430	1-216-073-00	RES,CHIP	10K 5%	1/10W	R1503	1-216-063-91	RES,CHIP	3.9K 5%	1/10W
R1431	1-216-129-00	RES,CHIP	2.2M 5%	1/10W	R1504	1-216-686-11	METAL CHIP	30K 0.50%	1/10W
					R1505	1-247-688-11	CARBON	10 5%	1/4W F

The components identified by shading and mark Δ are critical for safety. Replace only with part number specified.

Les composants identifiés par une trame et une marque Δ sont critiques pour la sécurité. Ne les remplacer que par une pièce portant le numéro spécifié.

• The components identified by \boxtimes in this manual have been carefully factory-selected for each set in order to satisfy regulations regarding X-ray radiation. Should replacement be required, replace only with the value originally used.



REF. NO.	PART NO.	DESCRIPTION	REMARK	REF. NO.	PART NO.	DESCRIPTION	REMARK
R1506	1-216-033-00	RES,CHIP 220	5% 1/10W	R2305	1-216-085-00	RES,CHIP 33K	5% 1/10W
R1507	1-216-065-91	RES,CHIP 4.7K	5% 1/10W	R2306	1-216-089-91	RES,CHIP 47K	5% 1/10W
R1508	1-216-083-00	RES,CHIP 27K	5% 1/10W	R2307	1-216-033-00	RES,CHIP 220	5% 1/10W
R1510	1-216-077-00	RES,CHIP 15K	5% 1/10W	R2308	1-216-103-00	RES,CHIP 180K	5% 1/10W
R1511	1-216-360-11	METAL OXIDE 8.2	5% 1W F	R2309	1-216-049-91	RES,CHIP 1K	5% 1/10W
R1512	1-216-647-11	METAL CHIP 680	0.50% 1/10W	R2310	1-216-095-00	RES,CHIP 82K	5% 1/10W
R1513	1-247-752-11	CARBON 1K	5% 1/2W F	R2311	1-216-073-00	RES,CHIP 10K	5% 1/10W
R1514	1-247-711-11	CARBON 680	5% 1/4W F	R2312	1-216-053-00	RES,CHIP 1.5K	5% 1/10W
R1515	1-216-350-11	METAL OXIDE 1.2	5% 1W F	R2313	1-216-049-91	RES,CHIP 1K	5% 1/10W
R1517	1-216-109-00	RES,CHIP 330K	5% 1/10W	R2314	1-216-645-11	METAL CHIP 560	0.50% 1/10W
R1518	1-215-867-00	METAL OXIDE 470	5% 1W F	R2315	1-216-679-11	METAL CHIP 15K	0.50% 1/10W
R1519	1-216-355-11	METAL OXIDE 3.3	5% 1W F	R2316	1-216-081-00	RES,CHIP 22K	5% 1/10W
R1520	1-216-027-00	RES,CHIP 120	5% 1/10W	R2317	1-216-049-91	RES,CHIP 1K	5% 1/10W
R1521	1-216-029-00	RES,CHIP 150	5% 1/10W	R2318	1-216-069-00	RES,CHIP 6.8K	5% 1/10W
R1523	1-216-350-11	METAL OXIDE 1.2	5% 1W F	R2319	1-216-093-00	RES,CHIP 68K	5% 1/10W
R1524	1-216-427-00	METAL OXIDE 120	5% 1W F	R2320	1-216-677-11	METAL CHIP 12K	0.50% 1/10W
R1525	1-216-083-00	RES,CHIP 27K	5% 1/10W	R2321	1-216-057-00	RES,CHIP 2.2K	5% 1/10W
R1526	1-216-089-91	RES,CHIP 47K	5% 1/10W	R2322	1-216-065-91	RES,CHIP 4.7K	5% 1/10W
R1527	1-249-413-11	CARBON 470	5% 1/4W F	R2323	1-216-683-11	METAL CHIP 22K	0.50% 1/10W
R1528	1-215-869-11	METAL OXIDE 1K	5% 1W F	R2324	1-216-073-00	RES,CHIP 10K	5% 1/10W
R1529	1-202-829-11	SOLID 8.2K	20% 1/2W	R2325	1-216-063-91	RES,CHIP 3.9K	5% 1/10W
R1530	1-216-115-00	RES,CHIP 560K	5% 1/10W	R2326	1-216-041-00	RES,CHIP 470	5% 1/10W
R1531	1-247-697-11	CARBON 56	5% 1/4W F	R2327	1-216-059-00	RES,CHIP 2.7K	5% 1/10W
R1532	1-216-059-00	RES,CHIP 2.7K	5% 1/10W	R2328	1-216-049-91	RES,CHIP 1K	5% 1/10W
R1533	1-249-414-11	CARBON 560	5% 1/4W F	R2329	1-216-059-00	RES,CHIP 2.7K	5% 1/10W
R1534	1-216-659-11	METAL CHIP 2.2K	0.50% 1/10W	R2330	1-216-049-91	RES,CHIP 1K	5% 1/10W
\boxtimes R1536 Δ		METAL CHIP	1/10W	R2331	1-216-059-00	RES,CHIP 2.7K	5% 1/10W
R1537	1-249-389-11	CARBON 4.7	5% 1/4W F	R2332	1-216-049-91	RES,CHIP 1K	5% 1/10W
R1538	1-216-073-00	RES,CHIP 10K	5% 1/10W	R2333	1-216-089-91	RES,CHIP 47K	5% 1/10W
R1540	1-216-105-91	RES,CHIP 220K	5% 1/10W	R2334	1-216-041-00	RES,CHIP 470	5% 1/10W
R1541	1-216-081-00	RES,CHIP 22K	5% 1/10W	R2335	1-216-061-00	RES,CHIP 3.3K	5% 1/10W
R1543	1-216-027-00	RES,CHIP 120	5% 1/10W	R2336	1-216-065-91	RES,CHIP 4.7K	5% 1/10W
R1547	1-216-391-11	METAL OXIDE 1.5	5% 3W F	R2337	1-216-037-00	RES,CHIP 330	5% 1/10W
R1548	1-216-057-00	RES,CHIP 2.2K	5% 1/10W	R2338	1-216-073-00	RES,CHIP 10K	5% 1/10W
R1549	1-260-094-11	CARBON 390	5% 1/2W	R2339	1-216-037-00	RES,CHIP 330	5% 1/10W
R1550	1-216-105-91	RES,CHIP 220K	5% 1/10W	R2341	1-216-037-00	RES,CHIP 330	5% 1/10W
R1551	1-249-393-11	CARBON 10	5% 1/4W F	R2342	1-216-071-00	RES,CHIP 8.2K	5% 1/10W
R1552	1-216-091-00	RES,CHIP 56K	5% 1/10W	R2343	1-216-081-00	RES,CHIP 22K	5% 1/10W
R1553	1-216-091-00	RES,CHIP 56K	5% 1/10W	R2344	1-216-121-91	RES,CHIP 1M	5% 1/10W
R1554	1-216-059-00	RES,CHIP 2.7K	5% 1/10W	R2345	1-216-681-11	METAL CHIP 18K	0.50% 1/10W
R1555	1-216-295-91	SHORT 0		R2346	1-216-061-00	RES,CHIP 3.3K	5% 1/10W
R1556	1-216-071-00	RES,CHIP 8.2K	5% 1/10W	R2347	1-216-061-00	RES,CHIP 3.3K	5% 1/10W
R1557	1-218-760-11	METAL CHIP 220K	0.50% 1/10W	R2348	1-216-061-00	RES,CHIP 3.3K	5% 1/10W
R1558	1-249-393-11	CARBON 10	5% 1/4W F	R2349	1-216-679-11	METAL CHIP 15K	0.50% 1/10W
R1559	1-249-393-11	CARBON 10	5% 1/4W F	R2350	1-216-061-00	RES,CHIP 3.3K	5% 1/10W
R1560	1-216-049-91	RES,CHIP 1K	5% 1/10W	R2351	1-216-061-00	RES,CHIP 3.3K	5% 1/10W
R1561	1-216-097-91	RES,CHIP 100K	5% 1/10W	R2352	1-216-061-00	RES,CHIP 3.3K	5% 1/10W
R1562	1-216-089-91	RES,CHIP 47K	5% 1/10W	R2353	1-216-041-00	RES,CHIP 470	5% 1/10W
R1563	1-216-089-91	RES,CHIP 47K	5% 1/10W	R2354	1-216-025-91	RES,CHIP 100	5% 1/10W
R1565	1-216-113-00	RES,CHIP 470K	5% 1/10W	R2357	1-216-091-00	RES,CHIP 56K	5% 1/10W
R1567	1-216-089-91	RES,CHIP 47K	5% 1/10W	R2358	1-216-025-91	RES,CHIP 100	5% 1/10W
R1570	1-216-073-00	RES,CHIP 10K	5% 1/10W	R2361	1-216-099-00	RES,CHIP 120K	5% 1/10W
R1571	1-216-103-00	RES,CHIP 180K	5% 1/10W	R2362	1-216-081-00	RES,CHIP 22K	5% 1/10W
R1572	1-216-101-00	RES,CHIP 150K	5% 1/10W	R2363	1-216-065-91	RES,CHIP 4.7K	5% 1/10W
R1573	1-216-073-00	RES,CHIP 10K	5% 1/10W	R2364	1-216-025-91	RES,CHIP 100	5% 1/10W
R1574	1-216-041-00	RES,CHIP 470	5% 1/10W	R2365	1-216-687-11	METAL CHIP 33K	0.50% 1/10W
R1575	1-216-025-91	RES,CHIP 100	5% 1/10W	R2366	1-216-067-00	RES,CHIP 5.6K	5% 1/10W
R1576	1-216-025-91	RES,CHIP 100	5% 1/10W	R2367	1-216-099-00	RES,CHIP 120K	5% 1/10W
R1577	1-216-025-91	RES,CHIP 100	5% 1/10W	R2368	1-216-065-91	RES,CHIP 4.7K	5% 1/10W
R1578	1-216-065-91	RES,CHIP 4.7K	5% 1/10W	R2369	1-216-675-11	METAL CHIP 10K	0.50% 1/10W
R1579	1-216-689-11	METAL CHIP 39K	0.50% 1/10W	R2371	1-216-049-91	RES,CHIP 1K	5% 1/10W
R1595	1-216-041-00	RES,CHIP 470	5% 1/10W	R2372	1-216-113-00	RES,CHIP 470K	5% 1/10W
R1596	1-216-099-00	RES,CHIP 120K	5% 1/10W	R2374	1-216-097-91	RES,CHIP 100K	5% 1/10W
R2300	1-216-065-91	RES,CHIP 4.7K	5% 1/10W	R2375	1-216-089-91	RES,CHIP 47K	5% 1/10W
R2301	1-216-065-91	RES,CHIP 4.7K	5% 1/10W	R2376	1-216-089-91	RES,CHIP 47K	5% 1/10W
R2302	1-216-671-11	METAL CHIP 6.8K	0.50% 1/10W	R2377	1-216-033-00	RES,CHIP 220	5% 1/10W
R2303	1-216-093-00	RES,CHIP 68K	5% 1/10W	R2378	1-216-089-91	RES,CHIP 47K	5% 1/10W
R2304	1-216-105-91	RES,CHIP 220K	5% 1/10W	R2379	1-216-033-00	RES,CHIP 220	5% 1/10W

A

Les composants identifiés par une trame et une marque Δ sont critiques pour la sécurité. Ne les remplacer que par une pièce portant le numéro spécifié.

The components identified by shading and mark Δ are critical for safety. Replace only with part number specified.

REF. NO.	PART NO.	DESCRIPTION	REMARK
R2380	1-216-089-91	RES,CHIP	47K 5% 1/10W
R2381	1-216-089-91	RES,CHIP	47K 5% 1/10W
R2382	1-216-089-91	RES,CHIP	47K 5% 1/10W
R2383	1-216-033-00	RES,CHIP	220 5% 1/10W
R2384	1-216-689-11	RES,CHIP	39K 5% 1/10W
R2389	1-216-033-00	RES,CHIP	220 5% 1/10W
R2390	1-216-647-11	METAL CHIP	680 0.50% 1/10W
R2391	1-216-647-11	METAL CHIP	680 0.50% 1/10W
R2392	1-216-073-00	RES,CHIP	10K 5% 1/10W
R2393	1-216-073-00	RES,CHIP	10K 5% 1/10W
R2394	1-216-081-00	RES,CHIP	22K 5% 1/10W
R2396	1-216-041-00	RES,CHIP	470 5% 1/10W
R2397	1-216-113-00	RES,CHIP	470K 5% 1/10W
R2398	1-216-109-00	RES,CHIP	330K 5% 1/10W
R2399	1-216-073-00	RES,CHIP	10K 5% 1/10W
R2501	1-216-083-00	RES,CHIP	27K 5% 1/10W
R2502	1-216-085-00	RES,CHIP	33K 5% 1/10W
R2503	1-216-089-91	RES,CHIP	47K 5% 1/10W
R2504	1-216-101-00	RES,CHIP	150K 5% 1/10W
R2551	1-216-091-00	RES,CHIP	56K 5% 1/10W
R2552	1-216-085-00	RES,CHIP	33K 5% 1/10W
R2553	1-216-083-00	RES,CHIP	27K 5% 1/10W
R2555	1-216-055-00	RES,CHIP	1.8K 5% 1/10W
R2556	1-216-051-00	RES,CHIP	1.2K 5% 1/10W
R2557	1-216-067-00	RES,CHIP	5.6K 5% 1/10W
R2558	1-216-057-00	RES,CHIP	2.2K 5% 1/10W
R2559	1-216-039-00	RES,CHIP	390 5% 1/10W
R2560	1-216-069-00	RES,CHIP	6.8K 5% 1/10W
R2561	1-216-001-00	RES,CHIP	10 5% 1/10W
R2562	1-216-001-00	RES,CHIP	10 5% 1/10W
R2563	1-216-057-00	RES,CHIP	2.2K 5% 1/10W
R3301	1-216-073-00	RES,CHIP	10K 5% 1/10W
R3302	1-216-065-91	RES,CHIP	4.7K 5% 1/10W
R3303	1-216-065-91	RES,CHIP	4.7K 5% 1/10W
R3304	1-216-065-91	RES,CHIP	4.7K 5% 1/10W
R3308	1-216-097-91	RES,CHIP	100K 5% 1/10W
R3310	1-216-049-91	RES,CHIP	1K 5% 1/10W
R3311	1-216-689-11	RES,CHIP	39K 5% 1/10W
R3312	1-216-095-00	RES,CHIP	82K 5% 1/10W
R3317	1-216-675-11	METAL CHIP	10K 0.50% 1/10W
R3320	1-216-085-00	RES,CHIP	33K 5% 1/10W
R3323	1-216-089-91	RES,CHIP	47K 5% 1/10W
R3333	1-216-113-00	RES,CHIP	470K 5% 1/10W
R3334	1-216-073-00	RES,CHIP	10K 5% 1/10W
R3335	1-216-113-00	RES,CHIP	470K 5% 1/10W
R3336	1-216-045-00	RES,CHIP	680 5% 1/10W
R3337	1-216-099-00	RES,CHIP	120K 5% 1/10W
R3338	1-216-103-00	RES,CHIP	180K 5% 1/10W
R3339	1-216-045-00	RES,CHIP	680 5% 1/10W
R3346	1-216-025-91	RES,CHIP	100 5% 1/10W
R3347	1-216-025-91	RES,CHIP	100 5% 1/10W
R3348	1-216-025-91	RES,CHIP	100 5% 1/10W
R3349	1-216-025-91	RES,CHIP	100 5% 1/10W
R3350	1-216-119-00	RES,CHIP	820K 5% 1/10W
R3351	1-216-119-00	RES,CHIP	820K 5% 1/10W
R3355	1-216-089-91	RES,CHIP	47K 5% 1/10W
R3356	1-216-051-00	RES,CHIP	1.2K 5% 1/10W
R3357	1-216-051-00	RES,CHIP	1.2K 5% 1/10W
R3358	1-216-051-00	RES,CHIP	1.2K 5% 1/10W
R3359	1-216-081-00	RES,CHIP	22K 5% 1/10W
R3360	1-216-073-00	RES,CHIP	10K 5% 1/10W
R3361	1-216-089-91	RES,CHIP	47K 5% 1/10W
R3362	1-216-049-91	RES,CHIP	1K 5% 1/10W
R3363	1-216-049-91	RES,CHIP	1K 5% 1/10W
R3364	1-216-073-00	RES,CHIP	10K 5% 1/10W
R3376	1-216-081-00	RES,CHIP	22K 5% 1/10W
R3378	1-216-119-00	RES,CHIP	820K 5% 1/10W
R3390	1-216-057-00	RES,CHIP	2.2K 5% 1/10W
R3394	1-216-089-91	RES,CHIP	47K 5% 1/10W

REF. NO.	PART NO.	DESCRIPTION	REMARK
R3395	1-216-049-91	RES,CHIP	1K 5% 1/10W
R3396	1-216-041-00	RES,CHIP	470 5% 1/10W
R3398	1-216-685-11	METAL CHIP	27K 0.50% 1/10W
R3399	1-216-025-91	RES,CHIP	100 5% 1/10W
R3400	1-216-091-00	RES,CHIP	56K 5% 1/10W
R3401	1-216-061-00	RES,CHIP	3.3K 5% 1/10W
R3402	1-216-699-11	METAL CHIP	100K 0.50% 1/10W
R3403	1-216-025-91	RES,CHIP	100 5% 1/10W
R3404	1-216-073-00	RES,CHIP	10K 5% 1/10W
R3405	1-216-067-00	RES,CHIP	5.6K 5% 1/10W
R3406	1-216-073-00	RES,CHIP	10K 5% 1/10W
R3407	1-216-073-00	RES,CHIP	10K 5% 1/10W
R4401	1-216-085-00	RES,CHIP	33K 5% 1/10W
R4404	1-216-073-00	RES,CHIP	10K 5% 1/10W
R4405	1-216-067-00	RES,CHIP	5.6K 5% 1/10W
R4407	1-216-061-00	RES,CHIP	3.3K 5% 1/10W
R4408	1-216-059-00	RES,CHIP	2.7K 5% 1/10W
R4409	1-216-059-00	RES,CHIP	2.7K 5% 1/10W
R4410	1-216-059-00	RES,CHIP	2.7K 5% 1/10W
R4411	1-216-113-00	RES,CHIP	470K 5% 1/10W
R4412	1-216-113-00	RES,CHIP	470K 5% 1/10W
R4413	1-216-295-91	SHORT	0
R4414	1-216-295-91	SHORT	0
R4415	1-216-295-91	SHORT	0
R4416	1-216-295-91	SHORT	0
<VARIABLE RESISTOR>			
RV501	1-223-102-00	RES, ADJ, WIREWOUND 120	
<TRANSFORMER>			
T500	1-426-668-11	TRANSFORMER, FERRITE (HDT)	
T501	Δ 1-453-233-11	TRANSFORMER ASSY. FLYBACK	
<THERMISTOR>			
TH500	1-807-970-11	THERMISTOR	
<CRYSTAL>			
X101	1-579-175-11	VIBRATOR, CERAMIC	
X300	1-577-259-11	VIBRATOR, CRYSTAL	
X301	1-527-722-00	VIBRATOR, CRYSTAL	

* A-1298-297-A A BOARD, COMPLETE (20inch model)			

1-540-044-11 SOCKET, IC			
* 4-043-994-01 PLATE (CF), SHIELD			
* 4-058-301-01 RING, SHORT			
4-382-854-11 SCREW (M3X10), P, SW (+)			
7-682-948-01 SCREW +PSW 3X8			
7-685-663-79 SCREW +BVTP 4X16 TYPE2 IT-3			
<BAND PASS FILTER>			
BPF400	1-236-363-11	FILTER, BAND PASS	
<CAPACITOR>			
C105	1-163-251-11	CERAMIC CHIP 100PF	5% 50V
C106	1-163-251-11	CERAMIC CHIP 100PF	5% 50V
C114	1-163-031-11	CERAMIC CHIP 0.01MF	50V
C116	1-163-031-11	CERAMIC CHIP 0.01MF	50V
C117	1-163-031-11	CERAMIC CHIP 0.01MF	50V



REF. NO.	PART NO.	DESCRIPTION	REMARK	REF. NO.	PART NO.	DESCRIPTION	REMARK
C118	1-163-259-91	CERAMIC CHIP 220PF	5% 50V	C360	1-164-232-11	CERAMIC CHIP 0.01MF	10% 50V
C119	1-165-319-11	CERAMIC CHIP 0.1MF	50V	C361	1-163-031-11	CERAMIC CHIP 0.01MF	50V
C121	1-163-237-11	CERAMIC CHIP 27PF	5% 50V	C362	1-163-031-11	CERAMIC CHIP 0.01MF	50V
C123	1-165-319-11	CERAMIC CHIP 0.1MF	50V	C363	1-163-099-00	CERAMIC CHIP 18PF	5% 50V
C124	1-163-251-11	CERAMIC CHIP 100PF	5% 50V	C364	1-163-031-11	CERAMIC CHIP 0.01MF	50V
C132	1-163-141-00	CERAMIC CHIP 0.001MF	5% 50V	C365	1-106-343-00	MYLAR 0.001MF	10% 100V
C133	1-163-251-11	CERAMIC CHIP 100PF	5% 50V	C366	1-163-031-11	CERAMIC CHIP 0.01MF	50V
C134	1-163-251-11	CERAMIC CHIP 100PF	5% 50V	C367	1-163-031-11	CERAMIC CHIP 0.01MF	50V
C135	1-163-251-11	CERAMIC CHIP 100PF	5% 50V	C368	1-124-261-00	ELECT 10MF	20% 50V
C136	1-163-251-11	CERAMIC CHIP 100PF	5% 50V	C369	1-164-298-11	CERAMIC CHIP 0.15MF	10% 25V
C140	1-164-004-11	CERAMIC CHIP 0.1MF	10% 25V	C370	1-104-664-11	ELECT 47MF	20% 25V
C141	1-164-161-11	CERAMIC CHIP 0.0022MF	10% 50V	C371	1-104-664-11	ELECT 47MF	20% 25V
C142	1-163-259-91	CERAMIC CHIP 220PF	5% 50V	C372	1-163-031-11	CERAMIC CHIP 0.01MF	50V
C143	1-165-319-11	CERAMIC CHIP 0.1MF	50V	C373	1-163-141-00	CERAMIC CHIP 0.001MF	5% 50V
C144	1-165-319-11	CERAMIC CHIP 0.1MF	50V	C374	1-126-960-11	ELECT 1MF	20% 50V
C145	1-165-319-11	CERAMIC CHIP 0.1MF	50V	C375	1-163-259-91	CERAMIC CHIP 220PF	5% 50V
C154	1-163-037-11	CERAMIC CHIP 0.022MF	10% 50V	C376	1-126-959-11	ELECT 0.47MF	20% 50V
C155	1-163-023-00	CERAMIC CHIP 0.015MF	10% 50V	C377	1-163-809-11	CERAMIC CHIP 0.047MF	10% 25V
C156	1-163-019-00	CERAMIC CHIP 0.0068MF	10% 50V	C378	1-163-809-11	CERAMIC CHIP 0.047MF	10% 25V
C157	1-163-019-00	CERAMIC CHIP 0.0068MF	10% 50V	C379	1-163-031-11	CERAMIC CHIP 0.01MF	50V
C158	1-163-809-11	CERAMIC CHIP 0.047MF	10% 25V	C380	1-126-767-11	ELECT 1000MF	20% 16V
C159	1-164-344-11	CERAMIC CHIP 0.068MF	10% 25V	C381	1-163-031-11	CERAMIC CHIP 0.01MF	50V
C161	1-104-664-11	ELECT 47MF	20% 25V	C382	1-163-243-11	CERAMIC CHIP 47PF	5% 50V
C162	1-163-141-00	CERAMIC CHIP 0.001MF	5% 50V	C383	1-104-664-11	ELECT 47MF	20% 25V
C164	1-165-319-11	CERAMIC CHIP 0.1MF	50V	C384	1-163-249-11	CERAMIC CHIP 82PF	5% 50V
C165	1-165-319-11	CERAMIC CHIP 0.1MF	50V	C385	1-104-664-11	ELECT 47MF	20% 25V
C166	1-164-004-11	CERAMIC CHIP 0.1MF	10% 25V	C386	1-124-261-00	ELECT 10MF	20% 50V
C167	1-126-925-11	ELECT 470MF	20% 10V	C387	1-163-141-00	CERAMIC CHIP 0.001MF	5% 50V
C168	1-126-925-11	ELECT 470MF	20% 10V	C388	1-124-261-00	ELECT 10MF	20% 50V
C169	1-164-232-11	CERAMIC CHIP 0.01MF	10% 50V	C390	1-163-243-11	CERAMIC CHIP 47PF	5% 50V
C171	1-163-251-11	CERAMIC CHIP 100PF	5% 50V	C391	1-104-664-11	ELECT 47MF	20% 25V
C172	1-163-123-00	CERAMIC CHIP 180PF	5% 50V	C392	1-164-298-11	CERAMIC CHIP 0.15MF	10% 25V
C173	1-163-123-00	CERAMIC CHIP 180PF	5% 50V	C393	1-164-298-11	CERAMIC CHIP 0.15MF	10% 25V
C174	1-163-243-11	CERAMIC CHIP 47PF	5% 50V	C394	1-104-664-11	ELECT 47MF	20% 25V
C200	1-126-963-11	ELECT 4.7MF	20% 50V	C395	1-163-235-11	CERAMIC CHIP 22PF	5% 50V
C201	1-137-353-11	MYLAR 0.047MF	10% 100V	C396	1-164-299-11	CERAMIC CHIP 0.22MF	10% 25V
C202	1-163-017-00	CERAMIC CHIP 0.0047MF	10% 50V	C397	1-104-664-11	ELECT 47MF	20% 25V
C203	1-126-963-11	ELECT 4.7MF	20% 50V	C398	1-104-664-11	ELECT 47MF	20% 25V
C204	1-126-964-11	ELECT 10MF	20% 50V	C399	1-104-664-11	ELECT 47MF	20% 25V
C205	1-126-767-11	ELECT 1000MF	20% 16V	C400	1-164-004-11	CERAMIC CHIP 0.1MF	10% 25V
C206	1-128-526-11	ELECT 100MF	20% 25V	C401	1-164-346-11	CERAMIC CHIP 1MF	16V
C207	1-104-665-11	ELECT 100MF	20% 25V	C407	1-104-664-11	ELECT 47MF	20% 25V
C208	1-126-964-11	ELECT 10MF	20% 50V	C409	1-163-031-11	CERAMIC CHIP 0.01MF	50V
C209	1-126-963-11	ELECT 4.7MF	20% 50V	C411	1-164-004-11	CERAMIC CHIP 0.1MF	10% 25V
C304	1-164-004-11	CERAMIC CHIP 0.1MF	10% 25V	C414	1-163-031-11	CERAMIC CHIP 0.01MF	50V
C305	1-163-259-91	CERAMIC CHIP 220PF	5% 50V	C415	1-126-964-11	ELECT 10MF	20% 50V
C306	1-163-031-11	CERAMIC CHIP 0.01MF	50V	C416	1-164-232-11	CERAMIC CHIP 0.01MF	10% 50V
C310	1-164-004-11	CERAMIC CHIP 0.1MF	10% 25V	C417	1-164-232-11	CERAMIC CHIP 0.01MF	10% 50V
C311	1-163-809-11	CERAMIC CHIP 0.047MF	10% 25V	C418	1-164-182-11	CERAMIC CHIP 0.0033MF	10% 50V
C312	1-126-961-11	ELECT 2.2MF	20% 50V	C419	1-126-925-11	ELECT 470MF	20% 10V
C313	1-163-145-00	CERAMIC CHIP 0.0015MF	5% 50V	C420	1-163-809-11	CERAMIC CHIP 0.047MF	10% 25V
C314	1-163-249-11	CERAMIC CHIP 82PF	5% 50V	C421	1-164-222-11	CERAMIC CHIP 0.22MF	25V
C315	1-126-964-11	ELECT 10MF	20% 50V	C422	1-126-960-11	ELECT 1MF	20% 50V
C316	1-104-664-11	ELECT 47MF	20% 25V	C423	1-163-809-11	CERAMIC CHIP 0.047MF	10% 25V
C318	1-126-964-11	ELECT 10MF	20% 50V	C424	1-163-809-11	CERAMIC CHIP 0.047MF	10% 25V
C325	1-126-964-11	ELECT 10MF	20% 50V	C426	1-163-243-11	CERAMIC CHIP 47PF	5% 50V
C328	1-163-031-11	CERAMIC CHIP 0.01MF	50V	C427	1-163-031-11	CERAMIC CHIP 0.01MF	50V
C340	1-163-031-11	CERAMIC CHIP 0.01MF	50V	C429	1-163-031-11	CERAMIC CHIP 0.01MF	50V
C343	1-163-031-11	CERAMIC CHIP 0.01MF	50V	C430	1-104-661-91	ELECT 330MF	20% 16V
C349	1-163-141-00	CERAMIC CHIP 0.001MF	5% 50V	C431	1-165-319-11	CERAMIC CHIP 0.1MF	50V
C350	1-163-141-00	CERAMIC CHIP 0.001MF	5% 50V	C433	1-163-235-11	CERAMIC CHIP 22PF	5% 50V
C352	1-163-031-11	CERAMIC CHIP 0.01MF	50V	C434	1-164-004-11	CERAMIC CHIP 0.1MF	10% 25V
C353	1-165-319-11	CERAMIC CHIP 0.1MF	50V	C435	1-163-089-00	CERAMIC CHIP 6PF	0.25PF 50V
C354	1-163-121-00	CERAMIC CHIP 150PF	5% 50V	C437	1-164-004-11	CERAMIC CHIP 0.1MF	10% 25V
C355	1-126-960-11	ELECT 1MF	20% 50V	C439	1-163-809-11	CERAMIC CHIP 0.047MF	10% 25V
C356	1-126-963-11	ELECT 4.7MF	20% 50V	C440	1-164-004-11	CERAMIC CHIP 0.1MF	10% 25V
C357	1-163-031-11	CERAMIC CHIP 0.01MF	50V	C441	1-126-962-11	ELECT 3.3MF	20% 50V
C358	1-163-031-11	CERAMIC CHIP 0.01MF	50V	C442	1-163-809-11	CERAMIC CHIP 0.047MF	10% 25V
C359	1-104-664-11	ELECT 47MF	20% 25V				

A

Les composants identifiés par une trame et une marque Δ sont critiques pour la sécurité. Ne les remplacer que par une pièce portant le numéro spécifié.

The components identified by shading and mark Δ are critical for safety. Replace only with part number specified.

REF. NO.	PART NO.	DESCRIPTION	REMARK
C443	1-163-107-00	CERAMIC CHIP 39PF	5% 50V
C444	1-165-319-11	CERAMIC CHIP 0.1MF	50V
C446	1-163-229-11	CERAMIC CHIP 12PF	5% 50V
C447	1-163-263-11	CERAMIC CHIP 330PF	5% 50V
C448	1-163-107-00	CERAMIC CHIP 39PF	5% 50V
C449	1-163-227-11	CERAMIC CHIP 10PF	0.5PF 50V
C450	1-163-809-11	CERAMIC CHIP 0.047MF	10% 25V
C451	1-164-004-11	CERAMIC CHIP 0.1MF	10% 25V
C452	1-163-263-11	CERAMIC CHIP 330PF	5% 50V
C453	1-164-004-11	CERAMIC CHIP 0.1MF	10% 25V
C454	1-163-107-00	CERAMIC CHIP 39PF	5% 50V
C455	1-163-263-11	CERAMIC CHIP 330PF	5% 50V
C456	1-163-229-11	CERAMIC CHIP 12PF	5% 50V
C457	1-164-004-11	CERAMIC CHIP 0.1MF	10% 25V
C458	1-163-249-11	CERAMIC CHIP 82PF	5% 50V
C459	1-165-319-11	CERAMIC CHIP 0.1MF	50V
C460	1-164-004-11	CERAMIC CHIP 0.1MF	10% 25V
C461	1-163-119-00	CERAMIC CHIP 120PF	5% 50V
C462	1-164-004-11	CERAMIC CHIP 0.1MF	10% 25V
C463	1-164-004-11	CERAMIC CHIP 0.1MF	10% 25V
C464	1-164-299-11	CERAMIC CHIP 0.22MF	10% 25V
C465	1-163-231-11	CERAMIC CHIP 15PF	5% 50V
C466	1-163-119-00	CERAMIC CHIP 120PF	5% 50V
C467	1-163-119-00	CERAMIC CHIP 120PF	5% 50V
C469	1-163-037-11	CERAMIC CHIP 0.022MF	10% 50V
C470	1-163-243-11	CERAMIC CHIP 47PF	5% 50V
C471	1-163-105-00	CERAMIC CHIP 33PF	5% 50V
C472	1-163-031-11	CERAMIC CHIP 0.01MF	50V
C473	1-163-031-11	CERAMIC CHIP 0.01MF	50V
C475	1-163-031-11	CERAMIC CHIP 0.01MF	50V
C476	1-163-031-11	CERAMIC CHIP 0.01MF	50V
C477	1-164-299-11	CERAMIC CHIP 0.22MF	10% 25V
C478	1-126-964-11	ELECT 10MF	20% 50V
C479	1-163-121-00	CERAMIC CHIP 150PF	5% 50V
C483	1-163-249-11	CERAMIC CHIP 82PF	5% 50V
C484	1-163-113-00	CERAMIC CHIP 68PF	5% 50V
C485	1-163-113-00	CERAMIC CHIP 68PF	5% 50V
C486	1-163-249-11	CERAMIC CHIP 82PF	5% 50V
C487	1-163-235-11	CERAMIC CHIP 22PF	5% 50V
C490	1-164-336-11	CERAMIC CHIP 0.33MF	25V
C491	1-164-336-11	CERAMIC CHIP 0.33MF	25V
C492	1-164-336-11	CERAMIC CHIP 0.33MF	25V
C493	1-104-760-11	CERAMIC CHIP 0.047MF	10% 50V
C494	1-164-005-11	CERAMIC CHIP 0.47MF	25V
C495	1-126-964-11	ELECT 10MF	20% 50V
C496	1-163-249-11	CERAMIC CHIP 82PF	5% 50V
C497	1-163-011-11	CERAMIC CHIP 0.0015MF	10% 50V
C498	1-126-961-11	ELECT 2.2MF	20% 50V
C499	1-163-031-11	CERAMIC CHIP 0.01MF	50V
C500	1-164-004-11	CERAMIC CHIP 0.1MF	10% 25V
C501	1-164-182-11	CERAMIC CHIP 0.0033MF	10% 50V
C502	1-163-141-00	CERAMIC CHIP 0.001MF	5% 50V
C503	1-163-251-11	CERAMIC CHIP 100PF	5% 50V
C504	1-136-495-11	FILM 0.068MF	5% 50V
C505	1-163-199-00	CERAMIC CHIP 560PF	5% 50V
C506	1-126-959-11	ELECT 0.47MF	20% 50V
C507	1-128-526-11	ELECT 100MF	20% 25V
C508	1-130-497-00	MYLAR 0.15MF	5% 50V
C509	1-128-566-11	ELECT 470MF	20% 100V
C511	1-107-368-11	FILM 0.047MF	10% 200V
C512	1-126-959-11	ELECT 0.47MF	20% 50V
C513	1-124-261-00	ELECT 10MF	20% 50V
C514	Δ 1-129-718-91	FILM 0.022MF	5% 630V
C515	1-163-809-11	CERAMIC CHIP 0.047MF	10% 25V
C516	1-102-030-00	CERAMIC 330PF	10% 500V
C517	1-163-024-00	CERAMIC CHIP 0.018MF	10% 50V
C518	1-107-947-11	ELECT 220MF	20% 160V
C519	1-163-017-00	CERAMIC CHIP 0.0047MF	10% 50V

REF. NO.	PART NO.	DESCRIPTION	REMARK
C520	1-163-257-11	CERAMIC CHIP 180PF	5% 50V
C521	1-162-114-00	CERAMIC 0.0047MF	2KV
C522	1-126-768-11	ELECT 2200MF	20% 16V
C523	1-107-902-11	ELECT 1MF	20% 50V
C525	Δ 1-136-081-11	FILM 0.012MF	3% 2KV
C526	Δ 1-162-116-91	CERAMIC 680PF	10% 2KV
C529	1-107-901-11	ELECT 0.47MF	20% 50V
C530	1-104-666-11	ELECT 220MF	20% 25V
C531	1-104-664-11	ELECT 47MF	20% 25V
C532	1-163-031-11	CERAMIC CHIP 0.01MF	50V
C533	1-102-212-00	CERAMIC 820PF	10% 500V
C534	1-107-662-11	ELECT 22MF	20% 250V
C537	1-126-971-11	ELECT 470MF	20% 50V
C538	1-137-150-11	MYLAR 0.01MF	10% 100V
C539	1-130-480-00	FILM 0.0056MF	5% 50V
C540	1-163-133-00	CERAMIC CHIP 470PF	5% 50V
C541	1-107-905-11	ELECT 4.7MF	20% 50V
C542	1-136-481-11	MYLAR 0.0022MF	10% 100V
C543	1-136-481-11	MYLAR 0.0022MF	10% 100V
C544	1-137-150-11	MYLAR 0.01MF	10% 100V
C545	1-102-212-00	CERAMIC 820PF	10% 500V
C546	1-163-119-00	CERAMIC CHIP 120PF	5% 50V
C547	1-163-251-11	CERAMIC CHIP 100PF	5% 50V
C548	1-102-212-00	CERAMIC 820PF	10% 500V
C549	1-107-906-11	ELECT 10MF	20% 50V
C550	1-107-905-11	ELECT 4.7MF	20% 50V
C551	1-106-375-12	MYLAR 0.022MF	10% 100V
C552	1-107-889-11	ELECT 220MF	20% 25V
C553	1-106-389-00	MYLAR 0.082MF	10% 200V
C554	1-130-736-11	FILM 0.01MF	5% 50V
C555	1-126-964-11	ELECT 10MF	20% 50V
C556	1-126-964-11	ELECT 10MF	20% 50V
C557	1-106-381-12	MYLAR 0.039MF	10% 100V
C558	1-126-960-11	ELECT 1MF	20% 50V
C559	1-136-173-00	FILM 0.47MF	5% 50V
C561	1-136-159-00	FILM 0.033MF	5% 50V
C564	1-126-964-11	ELECT 10MF	20% 50V
C565	1-126-960-11	ELECT 1MF	20% 50V
C566	1-137-150-11	MYLAR 0.01MF	10% 100V
C567	1-136-499-11	FILM 0.047MF	5% 50V
C568	1-126-960-11	ELECT 1MF	20% 50V
C569	1-131-350-00	TANTALUM 3.3MF	10% 25V
C570	1-126-767-11	ELECT 1000MF	20% 16V
C571	1-164-232-11	CERAMIC CHIP 0.01MF	10% 50V
C572	1-104-709-11	ELECT 4.7MF	0 160V
C573	1-136-177-00	FILM 1MF	5% 50V
C576	1-102-244-00	CERAMIC 220PF	10% 500V
C577	1-107-906-11	ELECT 10MF	20% 50V
C578	1-136-111-00	FILM 1MF	5% 200V
C579	1-107-910-11	ELECT 100MF	20% 50V
C580	1-136-105-00	FILM 0.33MF	5% 200V
C581	1-126-963-11	ELECT 4.7MF	20% 50V
C582	1-102-002-00	CERAMIC 680PF	10% 500V
C583	1-136-541-11	FILM 1.5MF	5% 200V
C584	1-107-949-11	ELECT 2.2MF	20% 160V
C585	1-107-960-11	ELECT 4.7MF	20% 250V
C586	1-126-942-61	ELECT 1000MF	20% 25V
C587	1-102-030-00	CERAMIC 330PF	10% 500V
C588	1-107-906-11	ELECT 10MF	20% 50V
C589	1-102-030-00	CERAMIC 330PF	10% 500V
C590	1-107-903-11	ELECT 2.2MF	20% 50V
C591	1-107-365-11	FILM 0.015MF	10% 200V
C592	1-107-635-11	ELECT 4.7MF	20% 160V
C593	1-165-319-11	CERAMIC CHIP 0.1MF	50V
C594	1-163-229-11	CERAMIC CHIP 12PF	5% 50V
C595	1-107-889-11	ELECT 220MF	20% 25V
C596	1-104-665-11	ELECT 100MF	20% 25V
C597	1-164-346-11	CERAMIC CHIP 1MF	16V
C598	1-164-346-11	CERAMIC CHIP 1MF	16V



REF. NO.	PART NO.	DESCRIPTION	REMARK	REF. NO.	PART NO.	DESCRIPTION	REMARK		
C599	1-124-261-00	ELECT	10MF 20%	50V	C1391	1-136-165-00	FILM 0.1MF 5%	50V	
C1300	1-104-664-11	ELECT	47MF 20%	25V	C1394	1-126-967-11	ELECT 47MF 20%	50V	
C1302	1-163-131-00	CERAMIC CHIP	390PF 5%	50V	C1395	1-126-967-11	ELECT 47MF 20%	50V	
C1304	1-104-664-11	ELECT	47MF 20%	25V	C1396	1-163-275-11	CERAMIC CHIP	0.001MF 5%	50V
C1305	1-104-664-11	ELECT	47MF 20%	25V	C1397	1-163-031-11	CERAMIC CHIP	0.01MF 5%	50V
C1307	1-163-031-11	CERAMIC CHIP	0.01MF 5%	50V	C1398	1-124-234-00	ELECT	22MF 20%	16V
C1308	1-126-933-11	ELECT	100MF 20%	10V	C1399	1-104-664-11	ELECT	47MF 20%	25V
C1309	1-163-257-11	CERAMIC CHIP	180PF 5%	50V	C1400	1-163-031-11	CERAMIC CHIP	0.01MF 5%	50V
C1311	1-104-664-11	ELECT	47MF 20%	25V	C1401	1-136-173-00	FILM	0.47MF 5%	50V
C1312	1-163-031-11	CERAMIC CHIP	0.01MF 5%	50V	C1402	1-163-031-11	CERAMIC CHIP	0.01MF 5%	50V
C1313	1-163-031-11	CERAMIC CHIP	0.01MF 5%	50V	C1403	1-136-173-00	FILM	0.47MF 5%	50V
C1314	1-104-664-11	ELECT	47MF 20%	25V	C1404	1-164-299-11	CERAMIC CHIP	0.22MF 10%	25V
C1315	1-104-664-11	ELECT	47MF 20%	25V	C1408	1-163-107-00	CERAMIC CHIP	39PF 5%	50V
C1316	1-163-031-11	CERAMIC CHIP	0.01MF 5%	50V	C1500	1-126-768-11	ELECT	2200MF 20%	16V
C1317	1-104-664-11	ELECT	47MF 20%	25V	C1501	1-126-925-11	ELECT	470MF 20%	10V
C1318	1-104-664-11	ELECT	47MF 20%	25V	C1505	1-136-165-00	FILM	0.1MF 5%	50V
C1319	1-124-234-00	ELECT	22MF 20%	16V	C1506	1-104-661-91	ELECT	330MF 20%	16V
C1320	1-104-664-11	ELECT	47MF 20%	25V	C1507	1-163-141-00	CERAMIC CHIP	0.001MF 5%	50V
C1321	1-104-664-11	ELECT	47MF 20%	25V	C1508	1-126-963-11	ELECT	4.7MF 20%	50V
C1322	1-126-934-11	ELECT	220MF 20%	16V	C1509	1-126-964-11	ELECT	10MF 20%	50V
C1323	1-163-031-11	CERAMIC CHIP	0.01MF 5%	50V	C1510	1-126-963-11	ELECT	4.7MF 20%	50V
C1324	1-163-031-11	CERAMIC CHIP	0.01MF 5%	50V	C1511	1-164-232-11	CERAMIC CHIP	0.01MF 10%	50V
C1325	1-163-031-11	CERAMIC CHIP	0.01MF 5%	50V	C1512	1-126-963-11	ELECT	4.7MF 20%	50V
C1326	1-104-664-11	ELECT	47MF 20%	25V	C1513	1-163-197-00	CERAMIC CHIP	470PF 5%	50V
C1327	1-163-031-11	CERAMIC CHIP	0.01MF 5%	50V	C1514	1-130-477-00	MYLAR	0.0033MF 5%	50V
C1328	1-163-031-11	CERAMIC CHIP	0.01MF 5%	50V	C1515	1-126-964-11	ELECT	10MF 20%	50V
C1329	1-126-964-11	ELECT	10MF 20%	50V	C1516	1-163-063-91	CERAMIC CHIP	0.022MF 10%	50V
C1330	1-163-031-11	CERAMIC CHIP	0.01MF 5%	50V	C1517	1-128-526-11	ELECT	100MF 20%	10V
C1331	1-104-664-11	ELECT	47MF 20%	25V	C1518	1-107-909-11	ELECT	47MF 20%	16V
C1332	1-104-664-11	ELECT	47MF 20%	25V	C1520	1-162-129-00	CERAMIC	150PF 10%	2KV
C1333	1-104-664-11	ELECT	47MF 20%	25V	C1521	1-163-243-11	CERAMIC CHIP	47PF 5%	50V
C1334	1-163-227-11	CERAMIC CHIP	10PF 0.5PF	50V	C1530	1-163-031-11	CERAMIC CHIP	0.01MF 5%	50V
C1335	1-104-664-11	ELECT	47MF 20%	25V	C1538	1-163-251-11	CERAMIC CHIP	100PF 5%	50V
C1336	1-104-664-11	ELECT	47MF 20%	25V	C1539	1-163-119-00	CERAMIC CHIP	120PF 5%	50V
C1338	1-163-031-11	CERAMIC CHIP	0.01MF 5%	50V	C1540	1-163-263-11	CERAMIC CHIP	330PF 5%	50V
C1339	1-163-031-11	CERAMIC CHIP	0.01MF 5%	50V	C1541	1-163-121-00	CERAMIC CHIP	150PF 5%	50V
C1340	1-163-031-11	CERAMIC CHIP	0.01MF 5%	50V	C1542	1-163-121-00	CERAMIC CHIP	150PF 5%	50V
C1341	1-163-275-11	CERAMIC CHIP	0.001MF 5%	50V	C2501	1-164-232-11	CERAMIC CHIP	0.01MF 10%	50V
C1342	1-163-105-00	CERAMIC CHIP	33PF 5%	50V	C2502	1-164-232-11	CERAMIC CHIP	0.01MF 10%	50V
C1343	1-163-113-00	CERAMIC CHIP	68PF 5%	50V			<CONNECTOR>		
C1344	1-163-083-00	CERAMIC CHIP	1PF 0.25PF	50V	CN101	* 1-573-979-11	CONNECTOR, BOARD TO BOARD	11P	
C1345	1-124-261-00	ELECT	10MF 20%	50V	CN102	* 1-564-514-11	PLUG, CONNECTOR	11P	
C1346	1-124-589-11	ELECT	47MF 20%	16V	CN104	* 1-564-506-11	PLUG, CONNECTOR	3P	
C1347	1-163-031-11	CERAMIC CHIP	0.01MF 5%	50V	CN105	* 1-766-745-11	CONNECTOR, BOARD TO BOARD	12P	
C1348	1-163-127-00	CERAMIC CHIP	270PF 5%	50V	CN201	* 1-564-506-11	PLUG, CONNECTOR	3P	
C1349	1-163-117-00	CERAMIC CHIP	100PF 5%	50V	CN301	* 1-564-514-11	PLUG, CONNECTOR	11P	
C1350	1-164-232-11	CERAMIC CHIP	0.01MF 10%	50V	CN302	* 1-564-510-11	PLUG, CONNECTOR	7P	
C1351	1-126-160-11	ELECT	1MF 20%	50V	CN305	1-779-070-21	PIN, CONNECTOR	12P	
C1352	1-163-023-00	CERAMIC CHIP	0.015MF 10%	50V	CN306	* 1-564-506-11	PLUG, CONNECTOR	3P	
C1353	1-163-031-11	CERAMIC CHIP	0.01MF 5%	50V	CN401	* 1-564-511-11	PLUG, CONNECTOR	8P	
C1354	1-163-121-00	CERAMIC CHIP	150PF 5%	50V	CN402	* 1-564-515-11	PLUG, CONNECTOR	12P	
C1355	1-163-259-91	CERAMIC CHIP	220PF 5%	50V	CN501	* 1-580-798-11	CONNECTOR PIN (DY)	6P	
C1356	1-163-235-11	CERAMIC CHIP	22PF 5%	50V	CN502	* 1-573-964-11	PIN, CONNECTOR (PC BOARD)	6P	
C1357	1-104-661-91	ELECT	330MF 20%	16V	CN503	* 1-573-964-11	PIN, CONNECTOR (PC BOARD)	6P	
C1358	1-124-589-11	ELECT	47MF 20%	16V	CN504	* 1-564-506-11	PLUG, CONNECTOR	3P	
C1359	1-163-263-11	CERAMIC CHIP	330PF 5%	50V	CN505	* 1-564-506-11	PLUG, CONNECTOR	3P	
C1360	1-164-161-11	CERAMIC CHIP	0.0022MF 10%	50V	CN507	1-695-915-11	TAB (CONTACT)		
C1362	1-163-249-11	CERAMIC CHIP	82PF 5%	50V	CN508	1-766-240-11	PIN, CONNECTOR (PC BOARD)	2P	
C1363	1-163-235-11	CERAMIC CHIP	22PF 5%	50V			<COMPOSITION CIRCUIT BLOCK>		
C1364	1-163-133-00	CERAMIC CHIP	470PF 5%	50V	CP300	1-236-366-11	MODULE, TRAP		
C1365	1-163-227-11	CERAMIC CHIP	10PF 0.5PF	50V	CP301	1-236-365-11	MODULE, TRAP		
C1366	1-104-664-11	ELECT	47MF 20%	25V	CP302	1-808-654-21	MODULE		
C1367	1-104-664-11	ELECT	47MF 20%	25V	CP303	1-466-162-61	FILTER BLOCK, COM (CFB-4)		
C1372	1-104-664-11	ELECT	47MF 20%	25V					
C1373	1-104-664-11	ELECT	47MF 20%	25V					
C1374	1-104-664-11	ELECT	47MF 20%	25V					
C1375	1-126-963-11	ELECT	4.7MF 20%	50V					
C1378	1-163-231-11	CERAMIC CHIP	15PF 5%	50V					



REF. NO.	PART NO.	DESCRIPTION	REMARK	REF. NO.	PART NO.	DESCRIPTION	REMARK
<DIODE>							
D100	8-719-404-49	DIODE MA111		D422	8-719-404-49	DIODE MA111	
D101	8-719-800-76	DIODE 1SS226		D423	8-719-800-76	DIODE 1SS226	
D102	8-719-800-76	DIODE 1SS226		D424	8-719-404-49	DIODE MA111	
D103	8-719-045-70	DIODE 1SV230TPH3		D425	8-719-800-76	DIODE 1SS226	
D104	8-719-800-76	DIODE 1SS226		D427	8-719-404-49	DIODE MA111	
D105	8-719-800-76	DIODE 1SS226		D500	8-719-404-49	DIODE MA111	
D107	8-719-800-76	DIODE 1SS226		D501	8-719-977-03	DIODE DTZ5.6B	
D108	8-719-104-34	DIODE 1S2836		D502	8-719-979-80	DIODE UF5406	
D109	8-719-801-78	DIODE 1SS184		D503	8-719-404-49	DIODE MA111	
D111	8-719-977-05	DIODE DTZ6.2		D504	8-719-901-83	DIODE 1SS83	
D114	8-719-404-49	DIODE MA111		D505	8-719-028-72	DIODE RGP02-17EL-6433	
D115	8-719-977-05	DIODE DTZ6.2		D506	8-719-033-83	DIODE ERD07-15	
D116	8-719-404-49	DIODE MA111		D507	8-719-800-76	DIODE 1SS226	
D117	8-719-920-76	DIODE 1S2076		D508	8-719-800-76	DIODE 1SS226	
D200	8-719-977-46	DIODE DTZ13C		D510	8-719-302-43	DIODE EL1Z	
D300	8-719-025-07	DIODE 1SV232-TPH3		D512	8-719-979-80	DIODE UF5406	
D301	8-719-404-49	DIODE MA111		D513	8-719-404-49	DIODE MA111	
D303	8-719-977-05	DIODE DTZ6.2		D514	8-719-971-20	DIODE ERC38-06	
D304	8-719-801-78	DIODE 1SS184		D515	8-719-971-20	DIODE ERC38-06	
D305	8-719-800-76	DIODE 1SS226		D516	8-719-404-49	DIODE MA111	
D307	8-719-404-49	DIODE MA111		D517	8-719-404-49	DIODE MA111	
D308	8-719-404-49	DIODE MA111		D518	8-719-404-49	DIODE MA111	
D309	8-719-404-49	DIODE MA111		D519	8-719-404-49	DIODE MA111	
D310	8-719-104-34	DIODE 1S2836		D520	8-719-801-78	DIODE 1SS184	
D311	8-719-045-70	DIODE 1SV230TPH3		D521	8-719-404-49	DIODE MA111	
D313	8-719-801-78	DIODE 1SS184		D522	8-719-977-05	DIODE DTZ6.2	
D314	8-719-404-49	DIODE MA111		D523	8-719-404-49	DIODE MA111	
D315	8-719-404-49	DIODE MA111		D524	8-719-200-02	DIODE 10E-2	
D317	8-719-404-49	DIODE MA111		D525	8-719-200-02	DIODE 10E-2	
D320	8-719-404-49	DIODE MA111		D526	8-719-404-49	DIODE MA111	
D322	8-719-404-49	DIODE MA111		D527	8-719-200-02	DIODE 10E-2	
D323	8-719-404-49	DIODE MA111		D528	8-719-300-76	DIODE RH-1A	
D324	8-719-404-49	DIODE MA111		D529	8-719-200-02	DIODE 10E-2	
D325	8-719-801-78	DIODE 1SS184		D530	8-719-300-76	DIODE RH-1A	
D326	8-719-404-49	DIODE MA111		D531	8-719-977-32	DIODE DTZ11B	
D327	8-719-104-34	DIODE 1S2836		D532	8-719-800-76	DIODE 1SS226	
D332	8-719-404-49	DIODE MA111		D533	8-719-302-43	DIODE EL1Z	
D333	8-719-404-49	DIODE MA111		D534	8-719-404-49	DIODE MA111	
D335	8-719-404-49	DIODE MA111		D535	8-719-404-49	DIODE MA111	
D337	8-719-404-49	DIODE MA111		D536	8-719-800-76	DIODE 1SS226	
D338	8-719-404-49	DIODE MA111		D538	8-719-800-76	DIODE 1SS226	
D339	8-719-404-49	DIODE MA111		D539	8-719-404-49	DIODE MA111	
D344	8-719-801-78	DIODE 1SS184		D540	8-719-404-49	DIODE MA111	
D345	8-719-104-34	DIODE 1S2836		D541	8-719-801-78	DIODE 1SS184	
D346	8-719-104-34	DIODE 1S2836		D543	8-719-404-49	DIODE MA111	
D347	8-719-104-34	DIODE 1S2836		<DELAY LINE>			
D360	1-216-295-91	SHORT 0		DL300	1-415-633-11	DELAY LINE, Y	
D361	1-216-295-91	SHORT 0		DL301	1-415-632-11	DELAY LINE, Y	
D362	8-719-158-40	DIODE RD10SB1		DL401	1-409-547-11	DELAY LINE	
D363	8-719-158-40	DIODE RD10SB1		<FERRITE BEAD>			
D364	8-719-104-34	DIODE 1S2836		FB501	1-410-396-41	FERRITE 0.45UH	
D365	8-719-404-49	DIODE MA111		<FILTER>			
D381	8-719-404-49	DIODE MA111		FL300	1-236-547-11	TRAP, LC	
D401	8-719-404-49	DIODE MA111		FL401	1-236-364-11	FILTER, BAND PASS	
D404	8-719-800-76	DIODE 1SS226		<IC>			
D405	8-719-801-78	DIODE 1SS184		IC101	*8-759-478-14	IC uPD78P018FYCW-MD1	
D406	8-719-404-49	DIODE MA111		IC102	8-759-354-28	IC ST24C02FM6TR	
D407	8-719-404-49	DIODE MA111		IC103	8-759-008-48	IC MC74HC86F	
D408	8-719-404-49	DIODE MA111		IC104	8-759-262-59	IC uPD6451AGT-632-E2	
D410	8-719-404-49	DIODE MA111		IC105	8-759-196-70	IC M62358FP-E1	
D411	8-719-404-49	DIODE MA111					
D414	8-719-801-78	DIODE 1SS184					
D415	8-719-801-78	DIODE 1SS184					
D416	8-719-801-78	DIODE 1SS184					
D417	8-719-801-78	DIODE 1SS184					
D418	8-719-801-78	DIODE 1SS184					
D421	8-719-404-49	DIODE MA111					

A

REF. NO.	PART NO.	DESCRIPTION	REMARK	REF. NO.	PART NO.	DESCRIPTION	REMARK
Q320	8-729-422-29	TRANSISTOR 2SD601A-S		Q430	8-729-422-29	TRANSISTOR 2SD601A-S	
Q321	8-729-422-29	TRANSISTOR 2SD601A-S		Q431	8-729-422-29	TRANSISTOR 2SD601A-S	
Q322	8-729-422-29	TRANSISTOR 2SD601A-S		Q432	8-729-422-29	TRANSISTOR 2SD601A-S	
Q323	1-801-806-11	TRANSISTOR DTC144EKA-T146		Q433	1-801-806-11	TRANSISTOR DTC144EKA-T146	
Q324	1-801-806-11	TRANSISTOR DTC144EKA-T146		Q434	8-729-422-29	TRANSISTOR 2SD601A-S	
Q325	8-729-422-29	TRANSISTOR 2SD601A-S		Q435	1-801-806-11	TRANSISTOR DTC144EKA-T146	
Q326	8-729-422-29	TRANSISTOR 2SD601A-S		Q436	1-801-806-11	TRANSISTOR DTC144EKA-T146	
Q327	8-729-422-37	TRANSISTOR 2SB709A-R		Q437	1-801-806-11	TRANSISTOR DTC144EKA-T146	
Q328	8-729-141-53	TRANSISTOR 2SK94-X2X3X4		Q442	8-729-422-29	TRANSISTOR 2SD601A-S	
Q329	8-729-141-53	TRANSISTOR 2SK94-X2X3X4		Q443	8-729-216-22	TRANSISTOR 2SA1162-G	
Q330	8-729-422-37	TRANSISTOR 2SB709A-R		Q444	8-729-422-29	TRANSISTOR 2SD601A-S	
Q331	8-729-422-37	TRANSISTOR 2SB709A-R		Q445	1-801-806-11	TRANSISTOR DTC144EKA-T146	
Q332	1-801-806-11	TRANSISTOR DTC144EKA-T146		Q446	1-801-806-11	TRANSISTOR DTC144EKA-T146	
Q333	8-729-422-29	TRANSISTOR 2SD601A-S		Q447	1-801-806-11	TRANSISTOR DTC144EKA-T146	
Q335	8-729-422-29	TRANSISTOR 2SD601A-S		Q448	1-801-806-11	TRANSISTOR DTC144EKA-T146	
Q338	8-729-120-28	TRANSISTOR 2SC1623-L5L6		Q449	1-801-806-11	TRANSISTOR DTC144EKA-T146	
Q339	8-729-422-37	TRANSISTOR 2SB709A-R		Q500	8-729-422-37	TRANSISTOR 2SB709A-R	
Q341	8-729-920-39	TRANSISTOR IMT1US		Q501	8-729-821-87	TRANSISTOR 2SD1878-CA	
Q342	8-729-920-39	TRANSISTOR IMT1US		Q502	8-729-119-80	TRANSISTOR 2SC2688-LK	
Q343	8-729-920-39	TRANSISTOR IMT1US		Q503	8-729-033-29	TRANSISTOR 2SD1210(LK)-MT2	
Q345	8-729-422-29	TRANSISTOR 2SD601A-S		Q505	8-729-422-29	TRANSISTOR 2SD601A-S	
Q350	8-729-422-37	TRANSISTOR 2SB709A-R		Q506	8-729-422-29	TRANSISTOR 2SD601A-S	
Q351	8-729-422-29	TRANSISTOR 2SD601A-S		Q507	8-729-422-29	TRANSISTOR 2SD601A-S	
Q352	8-729-422-29	TRANSISTOR 2SD601A-S		Q508	8-729-422-37	TRANSISTOR 2SB709A-R	
Q353	8-729-422-29	TRANSISTOR 2SD601A-S		Q511	8-729-422-29	TRANSISTOR 2SD601A-S	
Q354	8-729-422-29	TRANSISTOR 2SD601A-S		Q512	8-729-195-82	TRANSISTOR 2SC2958-L	
Q355	8-729-422-29	TRANSISTOR 2SD601A-S		Q513	8-729-122-03	TRANSISTOR 2SA1220A-P	
Q356	1-801-806-11	TRANSISTOR DTC144EKA-T146		Q514	8-729-901-00	TRANSISTOR DTC124EK	
Q360	8-729-907-26	TRANSISTOR IMX1		Q515	8-729-106-92	TRANSISTOR 2SC2690A-Q	
Q361	8-729-027-38	TRANSISTOR DTA144EKA-T146		Q516	1-801-806-11	TRANSISTOR DTC144EKA-T146	
Q362	8-729-422-29	TRANSISTOR 2SD601A-S		Q517	8-729-027-38	TRANSISTOR DTA144EKA-T146	
Q363	8-729-422-29	TRANSISTOR 2SD601A-S		Q518	1-801-806-11	TRANSISTOR DTC144EKA-T146	
Q364	1-801-806-11	TRANSISTOR DTC144EKA-T146		Q519	1-801-806-11	TRANSISTOR DTC144EKA-T146	
Q365	1-801-806-11	TRANSISTOR DTC144EKA-T146		Q520	8-729-021-82	TRANSISTOR 2SD2396K	
Q366	8-729-422-37	TRANSISTOR 2SB709A-R		Q522	8-729-422-29	TRANSISTOR 2SD601A-S	
Q367	8-729-422-37	TRANSISTOR 2SB709A-R		Q523	8-729-422-29	TRANSISTOR 2SD601A-S	
Q368	8-729-422-37	TRANSISTOR 2SB709A-R		Q524	8-729-422-29	TRANSISTOR 2SD601A-S	
Q369	8-729-027-38	TRANSISTOR DTA144EKA-T146		Q525	8-729-422-37	TRANSISTOR 2SB709A-R	
Q372	1-801-806-11	TRANSISTOR DTC144EKA-T146		Q533	1-801-806-11	TRANSISTOR DTC144EKA-T146	
Q373	1-801-806-11	TRANSISTOR DTC144EKA-T146		Q534	8-729-422-29	TRANSISTOR 2SD601A-S	
Q380	1-801-806-11	TRANSISTOR DTC144EKA-T146		Q535	8-729-422-29	TRANSISTOR 2SD601A-S	
Q381	1-801-806-11	TRANSISTOR DTC144EKA-T146		Q2501	8-729-422-29	TRANSISTOR 2SD601A-S	
Q382	1-801-806-11	TRANSISTOR DTC144EKA-T146					
Q383	1-801-806-11	TRANSISTOR DTC144EKA-T146					
Q384	1-801-806-11	TRANSISTOR DTC144EKA-T146					
Q385	1-801-806-11	TRANSISTOR DTC144EKA-T146					
Q386	1-801-806-11	TRANSISTOR DTC144EKA-T146					
Q401	8-729-422-29	TRANSISTOR 2SD601A-S					
Q402	8-729-422-29	TRANSISTOR 2SD601A-S					
Q407	8-729-422-29	TRANSISTOR 2SD601A-S					
Q409	8-729-422-37	TRANSISTOR 2SB709A-R					
Q410	8-729-907-26	TRANSISTOR IMX1					
Q412	8-729-216-22	TRANSISTOR 2SA1162-G					
Q414	8-729-422-37	TRANSISTOR 2SB709A-R					
Q415	8-729-422-37	TRANSISTOR 2SB709A-R					
Q416	8-729-422-37	TRANSISTOR 2SB709A-R					
Q417	8-729-422-37	TRANSISTOR 2SB709A-R					
Q418	8-729-120-28	TRANSISTOR 2SC1623-L5L6					
Q419	8-729-422-37	TRANSISTOR 2SB709A-R					
Q420	8-729-422-37	TRANSISTOR 2SB709A-R					
Q421	1-801-806-11	TRANSISTOR DTC144EKA-T146					
Q422	8-729-120-28	TRANSISTOR 2SC1623-L5L6					
Q423	8-729-422-29	TRANSISTOR 2SD601A-S					
Q424	1-801-806-11	TRANSISTOR DTC144EKA-T146					
Q425	1-801-806-11	TRANSISTOR DTC144EKA-T146					
Q426	1-801-806-11	TRANSISTOR DTC144EKA-T146					
Q428	8-729-422-37	TRANSISTOR 2SB709A-R					
Q429	8-729-422-37	TRANSISTOR 2SB709A-R					

<RESISTOR>

R101	1-216-025-91	RES,CHIP	100	5%	1/10W
R102	1-216-025-91	RES,CHIP	100	5%	1/10W
R103	1-216-025-91	RES,CHIP	100	5%	1/10W
R104	1-216-073-00	RES,CHIP	10K	5%	1/10W
R105	1-216-059-00	RES,CHIP	2.7K	5%	1/10W
R106	1-216-065-91	RES,CHIP	4.7K	5%	1/10W
R107	1-216-065-91	RES,CHIP	4.7K	5%	1/10W
R108	1-216-065-91	RES,CHIP	4.7K	5%	1/10W
R109	1-216-065-91	RES,CHIP	4.7K	5%	1/10W
R110	1-216-073-00	RES,CHIP	10K	5%	1/10W
R113	1-216-085-00	RES,CHIP	33K	5%	1/10W
R117	1-216-073-00	RES,CHIP	10K	5%	1/10W
R119	1-216-073-00	RES,CHIP	10K	5%	1/10W
R130	1-216-099-00	RES,CHIP	120K	5%	1/10W
R132	1-216-065-91	RES,CHIP	4.7K	5%	1/10W
R134	1-216-065-91	RES,CHIP	4.7K	5%	1/10W
R137	1-216-065-91	RES,CHIP	4.7K	5%	1/10W
R140	1-216-033-00	RES,CHIP	220	5%	1/10W
R141	1-216-085-00	RES,CHIP	33K	5%	1/10W
R144	1-216-295-91	SHORT	0		
R149	1-216-065-91	RES,CHIP	4.7K	5%	1/10W
R151	1-216-061-00	RES,CHIP	3.3K	5%	1/10W
R154	1-216-065-91	RES,CHIP	4.7K	5%	1/10W
R155	1-216-083-00	RES,CHIP	27K	5%	1/10W



REF. NO.	PART NO.	DESCRIPTION		REMARK	REF. NO.	PART NO.	DESCRIPTION		REMARK	
R157	1-216-065-91	RES,CHIP	4.7K	5%	1/10W	R357	1-216-121-91	RES,CHIP	1M 5%	1/10W
R158	1-216-295-91	SHORT	0			R366	1-216-065-91	RES,CHIP	4.7K 5%	1/10W
R159	1-216-063-91	RES,CHIP	3.9K	5%	1/10W	R371	1-216-025-91	RES,CHIP	100 5%	1/10W
R160	1-216-061-00	RES,CHIP	3.3K	5%	1/10W	R372	1-216-073-00	RES,CHIP	10K 5%	1/10W
R162	1-216-065-91	RES,CHIP	4.7K	5%	1/10W	R373	1-216-645-11	METAL CHIP	560 0.50%	1/10W
R163	1-216-065-91	RES,CHIP	4.7K	5%	1/10W	R374	1-216-647-11	METAL CHIP	680 0.50%	1/10W
R164	1-216-067-00	RES,CHIP	5.6K	5%	1/10W	R375	1-216-073-00	RES,CHIP	10K 5%	1/10W
R165	1-216-295-91	SHORT	0			R376	1-216-111-91	RES,CHIP	390K 5%	1/10W
R167	1-216-061-00	RES,CHIP	3.3K	5%	1/10W	R378	1-216-114-00	RES,CHIP	510K 5%	1/10W
R168	1-216-085-00	RES,CHIP	33K	5%	1/10W	R379	1-216-067-00	RES,CHIP	5.6K 5%	1/10W
R169	1-216-107-00	RES,CHIP	270K	5%	1/10W	R380	1-216-065-91	RES,CHIP	4.7K 5%	1/10W
R171	1-216-031-00	RES,CHIP	180	5%	1/10W	R381	1-216-689-11	RES,CHIP	39K 5%	1/10W
R172	1-216-295-91	SHORT	0			R382	1-216-101-00	RES,CHIP	150K 5%	1/10W
R177	1-216-214-00	RES,CHIP	4.7K	5%	1/8W	R386	1-216-091-00	RES,CHIP	56K 5%	1/10W
R181	1-216-065-91	RES,CHIP	4.7K	5%	1/10W	R387	1-216-029-00	RES,CHIP	150 5%	1/10W
R184	1-216-649-11	METAL CHIP	820	0.50%	1/10W	R388	1-216-039-00	RES,CHIP	390 5%	1/10W
R185	1-216-073-00	RES,CHIP	10K	5%	1/10W	R389	1-216-649-11	METAL CHIP	820 0.50%	1/10W
R189	1-216-073-00	RES,CHIP	10K	5%	1/10W	R390	1-249-393-11	CARBON	10 5%	1/4W F
R190	1-216-049-91	RES,CHIP	1K	5%	1/10W	R393	1-216-073-00	RES,CHIP	10K 5%	1/10W
R192	1-216-073-00	RES,CHIP	10K	5%	1/10W	R394	1-216-083-00	RES,CHIP	27K 5%	1/10W
R195	1-216-071-00	RES,CHIP	8.2K	5%	1/10W	R395	1-216-651-11	METAL CHIP	1K 0.50%	1/10W
R200	1-216-686-11	METAL CHIP	30K	0.50%	1/10W	R397	1-216-113-00	RES,CHIP	470K 5%	1/10W
R201	1-216-049-91	RES,CHIP	1K	5%	1/10W	R398	1-216-105-91	RES,CHIP	220K 5%	1/10W
R202	1-212-857-00	FUSIBLE	10	5%	1/4W F	R399	1-216-111-91	RES,CHIP	390K 5%	1/10W
R203	1-260-095-11	CARBON	470	5%	1/2W	R400	1-216-113-00	RES,CHIP	470K 5%	1/10W
R204	1-260-072-11	CARBON	4.7	5%	1/2W	R404	1-216-029-00	RES,CHIP	150 5%	1/10W
R205	1-216-647-11	METAL CHIP	680	0.50%	1/10W	R405	1-216-121-91	RES,CHIP	1M 5%	1/10W
R206	1-216-073-00	RES,CHIP	10K	5%	1/10W	R406	1-216-083-00	RES,CHIP	27K 5%	1/10W
R207	1-216-065-91	RES,CHIP	4.7K	5%	1/10W	R407	1-216-085-00	RES,CHIP	33K 5%	1/10W
R208	1-216-065-91	RES,CHIP	4.7K	5%	1/10W	R408	1-216-689-11	METAL CHIP	39K 0.50%	1/10W
R209	1-216-073-00	RES,CHIP	10K	5%	1/10W	R410	1-216-069-00	RES,CHIP	6.8K 5%	1/10W
R210	1-216-061-00	RES,CHIP	3.3K	5%	1/10W	R411	1-216-033-00	RES,CHIP	220 5%	1/10W
R211	1-249-393-11	CARBON	10	5%	1/4W F	R413	1-216-121-91	RES,CHIP	1M 5%	1/10W
R302	1-216-025-91	RES,CHIP	100	5%	1/10W	R414	1-216-295-91	SHORT	0	
R304	1-216-025-91	RES,CHIP	100	5%	1/10W	R416	1-216-113-00	RES,CHIP	470K 5%	1/10W
R307	1-216-115-00	RES,CHIP	560K	5%	1/10W	R417	1-216-665-11	METAL CHIP	3.9K 0.50%	1/10W
R308	1-216-065-91	RES,CHIP	4.7K	5%	1/10W	R418	1-216-667-11	METAL CHIP	4.7K 0.50%	1/10W
R311	1-216-055-00	RES,CHIP	1.8K	5%	1/10W	R426	1-216-039-00	RES,CHIP	390 5%	1/10W
R312	1-216-073-00	RES,CHIP	10K	5%	1/10W	R428	1-216-097-91	RES,CHIP	100K 5%	1/10W
R313	1-216-648-11	METAL CHIP	750	0.50%	1/10W	R429	1-216-073-00	RES,CHIP	10K 5%	1/10W
R314	1-216-099-00	RES,CHIP	120K	5%	1/10W	R430	1-216-119-00	RES,CHIP	820K 5%	1/10W
R315	1-216-099-00	RES,CHIP	120K	5%	1/10W	R431	1-216-097-91	RES,CHIP	100K 5%	1/10W
R316	1-216-049-91	RES,CHIP	1K	5%	1/10W	R434	1-216-109-00	RES,CHIP	330K 5%	1/10W
R317	1-216-057-00	RES,CHIP	2.2K	5%	1/10W	R435	1-216-105-91	RES,CHIP	220K 5%	1/10W
R318	1-216-049-91	RES,CHIP	1K	5%	1/10W	R436	1-216-113-00	RES,CHIP	470K 5%	1/10W
R320	1-216-057-00	RES,CHIP	2.2K	5%	1/10W	R437	1-216-097-91	RES,CHIP	100K 5%	1/10W
R321	1-216-051-00	RES,CHIP	1.2K	5%	1/10W	R441	1-216-645-11	METAL CHIP	560 0.50%	1/10W
R322	1-216-035-00	RES,CHIP	270	5%	1/10W	R442	1-216-647-11	METAL CHIP	680 0.50%	1/10W
R323	1-216-109-00	RES,CHIP	330K	5%	1/10W	R443	1-216-049-91	RES,CHIP	1K 5%	1/10W
R324	1-216-101-00	RES,CHIP	150K	5%	1/10W	R444	1-216-105-91	RES,CHIP	220K 5%	1/10W
R325	1-216-037-00	RES,CHIP	330	5%	1/10W	R445	1-216-095-00	RES,CHIP	82K 5%	1/10W
R326	1-216-033-00	RES,CHIP	220	5%	1/10W	R447	1-216-069-00	RES,CHIP	6.8K 5%	1/10W
R328	1-216-121-91	RES,CHIP	1M	5%	1/10W	R449	1-216-073-00	RES,CHIP	10K 5%	1/10W
R329	1-216-055-00	RES,CHIP	1.8K	5%	1/10W	R451	1-216-037-00	RES,CHIP	330 5%	1/10W
R330	1-216-089-91	RES,CHIP	47K	5%	1/10W	R452	1-216-651-11	METAL CHIP	1K 0.50%	1/10W
R331	1-216-093-00	RES,CHIP	68K	5%	1/10W	R453	1-216-097-91	RES,CHIP	100K 5%	1/10W
R332	1-216-097-91	RES,CHIP	100K	5%	1/10W	R459	1-216-649-11	METAL CHIP	820 0.50%	1/10W
R333	1-216-097-91	RES,CHIP	100K	5%	1/10W	R460	1-216-295-91	SHORT	0	
R334	1-216-093-00	RES,CHIP	68K	5%	1/10W	R462	1-216-651-11	METAL CHIP	1K 0.50%	1/10W
R335	1-216-083-00	RES,CHIP	27K	5%	1/10W	R463	1-216-063-91	RES,CHIP	3.9K 5%	1/10W
R336	1-216-065-91	RES,CHIP	4.7K	5%	1/10W	R464	1-216-065-91	RES,CHIP	4.7K 5%	1/10W
R342	1-216-065-91	RES,CHIP	4.7K	5%	1/10W	R465	1-216-025-91	RES,CHIP	100 5%	1/10W
R345	1-216-063-91	RES,CHIP	3.9K	5%	1/10W	R466	1-216-077-00	RES,CHIP	15K 5%	1/10W
R346	1-216-057-00	RES,CHIP	2.2K	5%	1/10W	R468	1-216-105-91	RES,CHIP	220K 5%	1/10W
R349	1-216-694-11	METAL CHIP	62K	0.50%	1/10W	R469	1-216-063-91	RES,CHIP	3.9K 5%	1/10W
R350	1-216-085-00	RES,CHIP	33K	5%	1/10W	R471	1-216-109-00	RES,CHIP	330K 5%	1/10W
R351	1-216-061-00	RES,CHIP	3.3K	5%	1/10W	R472	1-216-077-00	RES,CHIP	15K 5%	1/10W
R354	1-216-119-00	RES,CHIP	820K	5%	1/10W	R473	1-216-121-91	RES,CHIP	1M 5%	1/10W

A

REF. NO.	PART NO.	DESCRIPTION	REMARK
R476	1-216-061-00	RES,CHIP	3.3K 5% 1/10W
R477	1-216-061-00	RES,CHIP	3.3K 5% 1/10W
R478	1-216-073-00	RES,CHIP	10K 5% 1/10W
R479	1-216-085-00	RES,CHIP	33K 5% 1/10W
R482	1-216-057-00	RES,CHIP	2.2K 5% 1/10W
R483	1-216-025-91	RES,CHIP	100 5% 1/10W
R484	1-216-651-11	METAL CHIP	1K 0.50% 1/10W
R485	1-216-033-00	RES,CHIP	220 5% 1/10W
R486	1-216-681-11	METAL CHIP	18K 0.50% 1/10W
R487	1-216-653-11	METAL CHIP	1.2K 0.50% 1/10W
R488	1-216-073-00	RES,CHIP	10K 5% 1/10W
R489	1-216-077-00	RES,CHIP	15K 5% 1/10W
R491	1-216-063-91	RES,CHIP	3.9K 5% 1/10W
R492	1-216-085-00	RES,CHIP	33K 5% 1/10W
R493	1-216-295-91	SHORT	0
R494	1-216-696-11	METAL CHIP	75K 0.50% 1/10W
R495	1-216-651-11	METAL CHIP	1K 0.50% 1/10W
R496	1-216-073-00	RES,CHIP	10K 5% 1/10W
R497	1-216-653-11	METAL CHIP	1.2K 0.50% 1/10W
R498	1-216-063-91	RES,CHIP	3.9K 5% 1/10W
R499	1-216-033-00	RES,CHIP	220 5% 1/10W
R500	1-216-689-11	RES,CHIP	39K 5% 1/10W
R501	1-216-077-00	RES,CHIP	15K 5% 1/10W
R502	1-216-677-11	METAL CHIP	12K 0.50% 1/10W
R503	1-216-677-11	METAL CHIP	12K 0.50% 1/10W
R504	1-216-111-91	RES,CHIP	390K 5% 1/10W
R505	1-216-067-00	RES,CHIP	5.6K 5% 1/10W
R506	1-216-073-00	RES,CHIP	10K 5% 1/10W
R507	1-216-083-00	RES,CHIP	27K 5% 1/10W
R508	1-216-105-91	RES,CHIP	220K 5% 1/10W
R509	1-216-089-91	RES,CHIP	47K 5% 1/10W
R510	1-216-097-91	RES,CHIP	100K 5% 1/10W
R511	1-216-099-00	RES,CHIP	120K 5% 1/10W
R512	1-216-055-00	RES,CHIP	1.8K 5% 1/10W
R513	1-216-295-91	SHORT	0
R514	1-216-295-91	SHORT	0
R515	1-216-675-11	METAL CHIP	10K 0.50% 1/10W
R516	1-216-097-91	RES,CHIP	100K 5% 1/10W
R517	1-214-896-81	METAL	20K 1% 1/2W
R518	1-260-123-11	CARBON	100K 5% 1/2W
R519	1-216-017-91	RES,CHIP	47 5% 1/10W
R520	1-249-423-11	CARBON	3.3K 5% 1/4W F
R521	1-216-065-91	RES,CHIP	4.7K 5% 1/10W
R523	1-215-892-11	METAL OXIDE	1K 5% 2W F
R524	1-216-093-00	RES,CHIP	68K 5% 1/10W
R525	1-216-069-00	RES,CHIP	6.8K 5% 1/10W
R526	1-216-089-91	RES,CHIP	47K 5% 1/10W
R527	1-216-089-91	RES,CHIP	47K 5% 1/10W
R528	1-216-089-91	RES,CHIP	47K 5% 1/10W
R529	1-216-089-91	RES,CHIP	47K 5% 1/10W
R530	1-216-367-11	METAL OXIDE	0.68 5% 2W F
R531	1-216-077-00	RES,CHIP	15K 5% 1/10W
R532	1-215-916-00	METAL OXIDE	680 5% 3W F
R533	1-247-723-11	CARBON	6.8K 5% 1/4W F
R534	1-216-085-00	RES,CHIP	33K 5% 1/10W
R535	1-249-448-11	CARBON	1.2 5% 1/4W F
R536	1-216-101-00	RES,CHIP	150K 5% 1/10W
R537	1-216-089-91	RES,CHIP	47K 5% 1/10W
R538	1-215-916-00	METAL OXIDE	680 5% 3W F
R539	1-216-065-91	RES,CHIP	4.7K 5% 1/10W
R540	1-216-113-00	RES,CHIP	470K 5% 1/10W
R541	1-249-383-11	CARBON	1.5 5% 1/4W F
R542	1-216-057-00	RES,CHIP	2.2K 5% 1/10W
R543	1-212-883-00	FUSIBLE	120 5% 1/4W F
R544	1-216-095-00	RES,CHIP	82K 5% 1/10W
R545	1-216-073-00	RES,CHIP	10K 5% 1/10W
R546	1-249-425-11	CARBON	4.7K 5% 1/4W F
R547	1-216-091-00	RES,CHIP	56K 5% 1/10W
R548	1-216-057-00	RES,CHIP	2.2K 5% 1/10W

REF. NO.	PART NO.	DESCRIPTION	REMARK
R549	1-216-677-11	METAL CHIP	12K 0.50% 1/10W
R550	1-216-053-00	RES,CHIP	1.5K 5% 1/10W
R551	1-216-077-00	RES,CHIP	15K 5% 1/10W
R552	1-216-033-00	RES,CHIP	220 5% 1/10W
R553	1-216-083-00	RES,CHIP	27K 5% 1/10W
R554	1-216-095-00	RES,CHIP	82K 5% 1/10W
R555	1-216-692-11	METAL CHIP	51K 0.50% 1/10W
R556	1-215-897-11	METAL OXIDE	6.8K 5% 2W F
R557	1-216-462-00	METAL OXIDE	8.2K 5% 2W F
R558	1-215-891-11	METAL OXIDE	680 5% 2W F
R559	1-216-109-00	RES,CHIP	330K 5% 1/10W
R560	1-216-091-00	RES,CHIP	56K 5% 1/10W
R561	1-216-049-91	RES,CHIP	1K 5% 1/10W
R562	1-247-692-11	CARBON	22 5% 1/4W F
R563	1-216-017-91	RES,CHIP	47 5% 1/10W
R564	1-216-107-00	RES,CHIP	270K 5% 1/10W
R565	1-216-033-00	RES,CHIP	220 5% 1/10W
R566	1-216-685-11	METAL CHIP	27K 0.50% 1/10W
R567	1-216-081-00	RES,CHIP	22K 5% 1/10W
R568	1-216-073-00	RES,CHIP	10K 5% 1/10W
R569	1-260-119-11	CARBON	47K 5% 1/2W
R571	1-216-065-91	RES,CHIP	4.7K 5% 1/10W
R572	1-216-059-00	RES,CHIP	2.7K 5% 1/10W
R573	1-216-071-00	RES,CHIP	8.2K 5% 1/10W
R575	1-249-383-11	CARBON	1.5 5% 1/4W F
R576	1-216-101-00	RES,CHIP	150K 5% 1/10W
R578	1-216-693-11	METAL CHIP	56K 0.50% 1/10W
R579	1-216-077-00	RES,CHIP	15K 5% 1/10W
R580	1-216-105-91	RES,CHIP	220K 5% 1/10W
R582	1-216-085-00	RES,CHIP	33K 5% 1/10W
R583	1-216-039-00	RES,CHIP	390 5% 1/10W
R584	1-216-073-00	RES,CHIP	10K 5% 1/10W
R585	1-216-033-00	RES,CHIP	220 5% 1/10W
R586	1-216-686-11	METAL CHIP	30K 0.50% 1/10W
R587	1-216-675-11	METAL CHIP	10K 0.50% 1/10W
R588	1-216-077-00	RES,CHIP	15K 5% 1/10W
R589	1-216-067-00	RES,CHIP	5.6K 5% 1/10W
R590	1-216-081-00	RES,CHIP	22K 5% 1/10W
R591	1-216-682-11	METAL CHIP	20K 0.50% 1/10W
R592	1-247-688-11	CARBON	10 5% 1/4W F
R593	1-216-647-11	METAL CHIP	680 0.50% 1/10W
R594	1-247-713-11	CARBON	1K 5% 1/4W
R595	1-216-689-11	RES,CHIP	39K 5% 1/10W
R596	1-214-754-00	METAL	11K 1% 1/4W
R597	1-249-417-11	CARBON	1K 5% 1/4W F
R598	1-216-085-00	RES,CHIP	33K 5% 1/10W
R599	1-216-645-11	METAL CHIP	560 0.50% 1/10W
R1103	1-216-077-00	RES,CHIP	15K 5% 1/10W
R1104	1-216-699-11	METAL CHIP	100K 0.50% 1/10W
R1105	1-216-073-00	RES,CHIP	10K 5% 1/10W
R1106	1-216-097-91	RES,CHIP	100K 5% 1/10W
R1107	1-216-059-00	RES,CHIP	2.7K 5% 1/10W
R1108	1-216-681-11	METAL CHIP	18K 0.50% 1/10W
R1113	1-216-081-00	RES,CHIP	22K 5% 1/10W
R1123	1-216-071-00	RES,CHIP	8.2K 5% 1/10W
R1125	1-216-049-91	RES,CHIP	1K 5% 1/10W
R1126	1-216-041-00	RES,CHIP	470 5% 1/10W
R1128	1-216-065-91	RES,CHIP	4.7K 5% 1/10W
R1129	1-216-071-00	RES,CHIP	8.2K 5% 1/10W
R1130	1-216-049-91	RES,CHIP	1K 5% 1/10W
R1131	1-216-049-91	RES,CHIP	1K 5% 1/10W
R1132	1-216-071-00	RES,CHIP	8.2K 5% 1/10W
R1133	1-216-069-00	RES,CHIP	6.8K 5% 1/10W
R1134	1-216-073-00	RES,CHIP	10K 5% 1/10W
R1136	1-216-097-91	RES,CHIP	100K 5% 1/10W
R1139	1-216-055-00	RES,CHIP	1.8K 5% 1/10W
R1140	1-216-653-11	METAL CHIP	1.2K 0.50% 1/10W
R1141	1-216-073-00	RES,CHIP	10K 5% 1/10W



REF. NO.	PART NO.	DESCRIPTION			REMARK	REF. NO.	PART NO.	DESCRIPTION			REMARK
R1142	1-216-653-11	METAL CHIP	1.2K	0.50%	1/10W	R1338	1-216-647-11	METAL CHIP	680	0.50%	1/10W
R1143	1-216-653-11	METAL CHIP	1.2K	0.50%	1/10W	R1339	1-216-033-00	RES,CHIP	220	5%	1/10W
R1146	1-216-057-00	RES,CHIP	2.2K	5%	1/10W	R1340	1-216-033-00	RES,CHIP	220	5%	1/10W
R1147	1-216-057-00	RES,CHIP	2.2K	5%	1/10W	R1341	1-216-033-00	RES,CHIP	220	5%	1/10W
R1150	1-216-037-00	RES,CHIP	330	5%	1/10W	R1342	1-216-083-00	RES,CHIP	27K	5%	1/10W
R1151	1-216-081-00	RES,CHIP	22K	5%	1/10W	R1343	1-216-037-00	RES,CHIP	330	5%	1/10W
R1155	1-216-133-00	RES,CHIP	3.3M	5%	1/10W	R1344	1-216-093-00	RES,CHIP	68K	5%	1/10W
R1163	1-216-033-00	RES,CHIP	220	5%	1/10W	R1345	1-216-109-00	RES,CHIP	330K	5%	1/10W
R1164	1-216-049-91	RES,CHIP	1K	5%	1/10W	R1346	1-216-097-91	RES,CHIP	100K	5%	1/10W
R1165	1-216-049-91	RES,CHIP	1K	5%	1/10W	R1347	1-216-073-00	RES,CHIP	10K	5%	1/10W
R1170	1-216-089-91	RES,CHIP	47K	5%	1/10W	R1348	1-216-071-00	RES,CHIP	8.2K	5%	1/10W
R1171	1-216-085-00	RES,CHIP	33K	5%	1/10W	R1349	1-216-035-00	RES,CHIP	270	5%	1/10W
R1172	1-216-085-00	RES,CHIP	33K	5%	1/10W	R1350	1-216-073-00	RES,CHIP	10K	5%	1/10W
R1174	1-216-089-91	RES,CHIP	47K	5%	1/10W	R1351	1-216-033-00	RES,CHIP	220	5%	1/10W
R1177	1-216-071-00	RES,CHIP	8.2K	5%	1/10W	R1352	1-216-025-91	RES,CHIP	100	5%	1/10W
R1179	1-216-041-00	RES,CHIP	470	5%	1/10W	R1353	1-216-065-91	RES,CHIP	4.7K	5%	1/10W
R1180	1-216-089-91	RES,CHIP	47K	5%	1/10W	R1354	1-216-089-91	RES,CHIP	47K	5%	1/10W
R1182	1-216-131-11	RES,CHIP	2.7M	5%	1/10W	R1355	1-216-033-00	RES,CHIP	220	5%	1/10W
R1183	1-216-071-00	RES,CHIP	8.2K	5%	1/10W	R1356	1-216-105-91	RES,CHIP	220K	5%	1/10W
R1184	1-216-131-11	RES,CHIP	2.7M	5%	1/10W	R1357	1-216-101-00	RES,CHIP	150K	5%	1/10W
R1185	1-216-071-00	RES,CHIP	8.2K	5%	1/10W	R1358	1-216-071-00	RES,CHIP	8.2K	5%	1/10W
R1186	1-216-131-11	RES,CHIP	2.7M	5%	1/10W	R1359	1-216-099-00	RES,CHIP	120K	5%	1/10W
R1187	1-216-071-00	RES,CHIP	8.2K	5%	1/10W	R1360	1-216-065-91	RES,CHIP	4.7K	5%	1/10W
R1188	1-216-131-11	RES,CHIP	2.7M	5%	1/10W	R1361	1-216-113-00	RES,CHIP	470K	5%	1/10W
R1189	1-216-071-00	RES,CHIP	8.2K	5%	1/10W	R1362	1-216-676-11	METAL CHIP	11K	0.50%	1/10W
R1190	1-216-131-11	RES,CHIP	2.7M	5%	1/10W	R1363	1-216-113-00	RES,CHIP	470K	5%	1/10W
R1191	1-216-071-00	RES,CHIP	8.2K	5%	1/10W	R1364	1-216-073-00	RES,CHIP	10K	5%	1/10W
R1192	1-216-131-11	RES,CHIP	2.7M	5%	1/10W	R1365	1-216-131-11	RES,CHIP	2.7M	5%	1/10W
R1193	1-216-025-91	RES,CHIP	100	5%	1/10W	R1366	1-216-081-00	RES,CHIP	22K	5%	1/10W
R1194	1-216-085-00	RES,CHIP	33K	5%	1/10W	R1367	1-216-660-11	METAL CHIP	2.4K	0.50%	1/10W
R1195	1-216-025-91	RES,CHIP	100	5%	1/10W	R1368	1-216-059-00	RES,CHIP	2.7K	5%	1/10W
R1196	1-216-085-00	RES,CHIP	33K	5%	1/10W	R1369	1-216-051-00	RES,CHIP	1.2K	5%	1/10W
R1197	1-216-025-91	RES,CHIP	100	5%	1/10W	R1370	1-216-105-91	RES,CHIP	220K	5%	1/10W
R1198	1-216-085-00	RES,CHIP	33K	5%	1/10W	R1371	1-216-113-00	RES,CHIP	470K	5%	1/10W
R1303	1-216-073-00	RES,CHIP	10K	5%	1/10W	R1372	1-216-089-91	RES,CHIP	47K	5%	1/10W
R1304	1-216-689-11	RES,CHIP	39K	5%	1/10W	R1373	1-216-063-91	RES,CHIP	3.9K	5%	1/10W
R1305	1-216-033-00	RES,CHIP	220	5%	1/10W	R1374	1-216-101-00	RES,CHIP	150K	5%	1/10W
R1306	1-216-645-11	METAL CHIP	560	0.50%	1/10W	R1375	1-216-645-11	METAL CHIP	560	0.50%	1/10W
R1307	1-216-091-00	RES,CHIP	56K	5%	1/10W	R1376	1-216-647-11	METAL CHIP	680	0.50%	1/10W
R1308	1-216-645-11	METAL CHIP	560	0.50%	1/10W	R1378	1-216-065-91	RES,CHIP	4.7K	5%	1/10W
R1309	1-216-025-91	RES,CHIP	100	5%	1/10W	R1379	1-216-037-00	RES,CHIP	330	5%	1/10W
R1310	1-216-057-00	RES,CHIP	2.2K	5%	1/10W	R1380	1-216-645-11	METAL CHIP	560	0.50%	1/10W
R1311	1-216-089-91	RES,CHIP	47K	5%	1/10W	R1381	1-216-647-11	METAL CHIP	680	0.50%	1/10W
R1312	1-216-027-00	RES,CHIP	120	5%	1/10W	R1382	1-216-073-00	RES,CHIP	10K	5%	1/10W
R1313	1-216-097-91	RES,CHIP	100K	5%	1/10W	R1383	1-216-681-11	METAL CHIP	18K	0.50%	1/10W
R1314	1-216-081-00	RES,CHIP	22K	5%	1/10W	R1384	1-216-091-00	RES,CHIP	56K	5%	1/10W
R1315	1-216-073-00	RES,CHIP	10K	5%	1/10W	R1385	1-216-073-00	RES,CHIP	10K	5%	1/10W
R1316	1-216-065-91	RES,CHIP	4.7K	5%	1/10W	R1386	1-216-077-00	RES,CHIP	15K	5%	1/10W
R1317	1-216-033-00	RES,CHIP	220	5%	1/10W	R1387	1-216-653-11	METAL CHIP	1.2K	0.50%	1/10W
R1318	1-216-089-91	RES,CHIP	47K	5%	1/10W	R1388	1-216-689-11	METAL CHIP	39K	0.50%	1/10W
R1319	1-216-085-00	RES,CHIP	33K	5%	1/10W	R1389	1-216-657-11	METAL CHIP	1.8K	0.50%	1/10W
R1320	1-216-057-00	RES,CHIP	2.2K	5%	1/10W	R1390	1-216-647-11	METAL CHIP	680	0.50%	1/10W
R1321	1-216-649-11	METAL CHIP	820	0.50%	1/10W	R1391	1-216-025-91	RES,CHIP	100	5%	1/10W
R1322	1-216-057-00	RES,CHIP	2.2K	5%	1/10W	R1392	1-216-041-00	RES,CHIP	470	5%	1/10W
R1324	1-216-061-00	RES,CHIP	3.3K	5%	1/10W	R1393	1-216-063-91	RES,CHIP	3.9K	5%	1/10W
R1325	1-216-652-11	METAL CHIP	1.1K	0.50%	1/10W	R1394	1-216-041-00	RES,CHIP	470	5%	1/10W
R1326	1-216-073-00	RES,CHIP	10K	5%	1/10W	R1395	1-216-071-00	RES,CHIP	8.2K	5%	1/10W
R1327	1-216-073-00	RES,CHIP	10K	5%	1/10W	R1396	1-216-071-00	RES,CHIP	8.2K	5%	1/10W
R1328	1-216-125-00	RES,CHIP	1.5M	5%	1/10W	R1397	1-216-065-91	RES,CHIP	4.7K	5%	1/10W
R1329	1-216-103-00	RES,CHIP	180K	5%	1/10W	R1399	1-216-073-00	RES,CHIP	10K	5%	1/10W
R1330	1-216-081-00	RES,CHIP	22K	5%	1/10W	R1401	1-216-085-00	RES,CHIP	33K	5%	1/10W
R1331	1-216-679-11	METAL CHIP	15K	0.50%	1/10W	R1402	1-216-295-91	SHORT	0		
R1332	1-216-671-11	METAL CHIP	6.8K	0.50%	1/10W	R1403	1-216-651-11	METAL CHIP	1K	0.50%	1/10W
R1333	1-216-049-91	RES,CHIP	1K	5%	1/10W	R1404	1-216-681-11	METAL CHIP	18K	0.50%	1/10W
R1334	1-216-063-91	RES,CHIP	3.9K	5%	1/10W	R1405	1-216-071-00	RES,CHIP	8.2K	5%	1/10W
R1335	1-249-401-11	CARBON	47	5%	1/4W F	R1406	1-216-653-11	METAL CHIP	1.2K	0.50%	1/10W
R1336	1-216-095-00	RES,CHIP	82K	5%	1/10W	R1407	1-216-063-91	RES,CHIP	3.9K	5%	1/10W
R1337	1-216-061-00	RES,CHIP	3.3K	5%	1/10W	R1408	1-216-113-00	RES,CHIP	470K	5%	1/10W
						R1409	1-216-295-91	SHORT	0		

• The components identified by **■** in this manual have been carefully factory-selected for each set in order to satisfy regulations regarding X-ray radiation. Should replacement be required, replace only with the value originally used.

Les composants identifiés par une trame et une marque **△** sont critiques pour la sécurité. Ne les remplacer que par une pièce portant le numéro spécifié.

The components identified by shading and mark **△** are critical for safety. Replace only with part number specified.

A

REF. NO.	PART NO.	DESCRIPTION	REMARK
R1410	1-216-053-00	RES,CHIP	1.5K 5% 1/10W
R1411	1-216-073-00	RES,CHIP	10K 5% 1/10W
R1412	1-216-107-00	RES,CHIP	270K 5% 1/10W
R1413	1-216-081-00	RES,CHIP	22K 5% 1/10W
R1414	1-216-057-00	RES,CHIP	2.2K 5% 1/10W
R1415	1-216-093-00	RES,CHIP	68K 5% 1/10W
R1416	1-216-113-00	RES,CHIP	470K 5% 1/10W
R1417	1-216-033-00	RES,CHIP	220 5% 1/10W
R1418	1-216-033-00	RES,CHIP	220 5% 1/10W
R1419	1-216-025-91	RES,CHIP	100 5% 1/10W
R1420	1-216-089-91	RES,CHIP	47K 5% 1/10W
R1421	1-216-649-11	METAL CHIP	820 0.50% 1/10W
R1422	1-216-085-00	RES,CHIP	33K 5% 1/10W
R1423	1-216-057-00	RES,CHIP	2.2K 5% 1/10W
R1424	1-216-081-00	RES,CHIP	22K 5% 1/10W
R1425	1-216-013-00	RES,CHIP	33 5% 1/10W
R1426	1-216-113-00	RES,CHIP	470K 5% 1/10W
R1427	1-216-681-11	METAL CHIP	18K 0.50% 1/10W
R1428	1-216-061-00	RES,CHIP	3.3K 5% 1/10W
R1429	1-216-668-11	METAL CHIP	5.1K 0.50% 1/10W
R1430	1-216-073-00	RES,CHIP	10K 5% 1/10W
R1431	1-216-129-00	RES,CHIP	2.2M 5% 1/10W
R1432	1-216-089-91	RES,CHIP	47K 5% 1/10W
R1433	1-216-085-00	RES,CHIP	33K 5% 1/10W
R1434	1-216-645-11	METAL CHIP	560 0.50% 1/10W
R1435	1-216-055-00	RES,CHIP	1.8K 5% 1/10W
R1436	1-216-073-00	RES,CHIP	10K 5% 1/10W
R1437	1-216-069-00	RES,CHIP	6.8K 5% 1/10W
R1438	1-216-073-00	RES,CHIP	10K 5% 1/10W
R1439	1-216-059-00	RES,CHIP	2.7K 5% 1/10W
R1440	1-216-041-00	RES,CHIP	470 5% 1/10W
R1441	1-216-033-00	RES,CHIP	220 5% 1/10W
R1442	1-216-073-00	RES,CHIP	10K 5% 1/10W
R1443	1-216-013-00	RES,CHIP	33 5% 1/10W
R1444	1-216-057-00	RES,CHIP	2.2K 5% 1/10W
R1445	1-216-071-00	RES,CHIP	8.2K 5% 1/10W
R1446	1-216-071-00	RES,CHIP	8.2K 5% 1/10W
R1447	1-216-081-00	RES,CHIP	22K 5% 1/10W
R1448	1-216-085-00	RES,CHIP	33K 5% 1/10W
R1449	1-216-057-00	RES,CHIP	2.2K 5% 1/10W
R1450	1-216-129-00	RES,CHIP	2.2M 5% 1/10W
R1451	1-216-093-00	RES,CHIP	68K 5% 1/10W
R1452	1-216-085-00	RES,CHIP	33K 5% 1/10W
R1453	1-216-013-00	RES,CHIP	33 5% 1/10W
R1454	1-216-065-91	RES,CHIP	4.7K 5% 1/10W
R1455	1-216-113-00	RES,CHIP	470K 5% 1/10W
R1456	1-216-129-00	RES,CHIP	2.2M 5% 1/10W
R1457	1-216-089-91	RES,CHIP	47K 5% 1/10W
R1458	1-216-085-00	RES,CHIP	33K 5% 1/10W
R1459	1-216-133-00	RES,CHIP	3.3M 5% 1/10W
R1460	1-216-097-91	RES,CHIP	100K 5% 1/10W
R1461	1-216-645-11	METAL CHIP	560 0.50% 1/10W
R1462	1-216-645-11	METAL CHIP	560 0.50% 1/10W
R1463	1-216-645-11	METAL CHIP	560 0.50% 1/10W
R1464	1-216-057-00	RES,CHIP	2.2K 5% 1/10W
R1465	1-216-097-91	RES,CHIP	100K 5% 1/10W
R1466	1-216-055-00	RES,CHIP	1.8K 5% 1/10W
R1467	1-216-073-00	RES,CHIP	10K 5% 1/10W
R1468	1-216-091-00	RES,CHIP	56K 5% 1/10W
R1469	1-216-057-00	RES,CHIP	2.2K 5% 1/10W
R1470	1-216-061-00	RES,CHIP	3.3K 5% 1/10W
R1471	1-216-049-91	RES,CHIP	1K 5% 1/10W
R1472	1-216-085-00	RES,CHIP	33K 5% 1/10W
R1473	1-216-081-00	RES,CHIP	22K 5% 1/10W
R1475	1-216-677-11	METAL CHIP	12K 0.50% 1/10W
R1476	1-216-063-91	RES,CHIP	3.9K 5% 1/10W
R1477	1-216-057-00	RES,CHIP	2.2K 5% 1/10W
R1478	1-216-061-00	RES,CHIP	3.3K 5% 1/10W

REF. NO.	PART NO.	DESCRIPTION	REMARK
R1480	1-216-089-91	RES,CHIP	47K 5% 1/10W
R1481	1-216-115-00	RES,CHIP	560K 5% 1/10W
R1482	1-216-089-91	RES,CHIP	47K 5% 1/10W
R1483	1-216-089-91	RES,CHIP	47K 5% 1/10W
R1484	1-216-081-00	RES,CHIP	22K 5% 1/10W
R1485	1-216-113-00	RES,CHIP	470K 5% 1/10W
R1486	1-216-097-91	RES,CHIP	100K 5% 1/10W
R1487	1-216-097-91	RES,CHIP	100K 5% 1/10W
R1488	1-216-083-00	RES,CHIP	27K 5% 1/10W
R1490	1-216-035-00	RES,CHIP	270 5% 1/10W
R1491	1-216-035-00	RES,CHIP	270 5% 1/10W
R1492	1-216-035-00	RES,CHIP	270 5% 1/10W
R1493	1-216-083-00	RES,CHIP	27K 5% 1/10W
R1494	1-216-081-00	RES,CHIP	22K 5% 1/10W
R1495	1-216-089-91	RES,CHIP	47K 5% 1/10W
R1496	1-216-089-91	RES,CHIP	47K 5% 1/10W
R1498	1-216-065-91	RES,CHIP	4.7K 5% 1/10W
R1500	1-216-649-11	METAL CHIP	820 0.50% 1/10W
R1501	1-216-071-00	RES,CHIP	8.2K 5% 1/10W
R1502	1-260-111-11	CARBON	10K 5% 1/2W
R1503	1-216-063-91	RES,CHIP	3.9K 5% 1/10W
R1504	1-216-686-11	METAL CHIP	30K 0.50% 1/10W
R1505	1-247-688-11	CARBON	10 5% 1/4W F
R1506	1-216-041-00	RES,CHIP	470 5% 1/10W
R1507	1-216-065-91	RES,CHIP	4.7K 5% 1/10W
R1508	1-216-689-11	RES,CHIP	39K 5% 1/10W
R1510	1-216-077-00	RES,CHIP	15K 5% 1/10W
R1511	1-216-360-11	METAL OXIDE	8.2 5% 1W F
R1512	1-216-647-11	METAL CHIP	680 0.50% 1/10W
R1513	1-247-752-11	CARBON	1K 5% 1/2W F
R1514	1-247-711-11	CARBON	680 5% 1/4W F
R1515	1-216-350-11	METAL OXIDE	1.2 5% 1W F
R1517	1-216-109-00	RES,CHIP	330K 5% 1/10W
R1518	1-215-867-00	METAL OXIDE	470 5% 1W F
R1519	1-216-355-11	METAL OXIDE	3.3 5% 1W F
R1520	1-216-027-00	RES,CHIP	120 5% 1/10W
R1521	1-216-029-00	RES,CHIP	150 5% 1/10W
R1523	1-216-350-11	METAL OXIDE	1.2 5% 1W F
R1524	1-216-427-00	METAL OXIDE	120 5% 1W F
R1525	1-216-083-00	RES,CHIP	27K 5% 1/10W
R1526	1-216-089-91	RES,CHIP	47K 5% 1/10W
R1527	1-249-413-11	CARBON	470 5% 1/4W F
R1528	1-215-869-11	METAL OXIDE	1K 5% 1W F
R1529	1-202-829-11	SOLID	8.2K 20% 1/2W
R1530	1-216-115-00	RES,CHIP	560K 5% 1/10W
R1531	1-247-697-11	CARBON	56 5% 1/4W F
R1532	1-216-059-00	RES,CHIP	2.7K 5% 1/10W
R1533	1-249-414-11	CARBON	560 5% 1/4W F
R1534	1-216-659-11	METAL CHIP	2.2K 0.50% 1/10W
■ R1536 △		METAL CHIP	1/10W
R1537	1-249-389-11	CARBON	4.7 5% 1/4W F
R1538	1-216-073-00	RES,CHIP	10K 5% 1/10W
R1540	1-216-105-91	RES,CHIP	220K 5% 1/10W
R1541	1-216-081-00	RES,CHIP	22K 5% 1/10W
R1543	1-216-027-00	RES,CHIP	120 5% 1/10W
R1547	1-216-391-11	METAL OXIDE	1.5 5% 3W F
R1548	1-216-057-00	RES,CHIP	2.2K 5% 1/10W
R1549	1-260-094-11	CARBON	390 5% 1/2W
R1550	1-216-105-91	RES,CHIP	220K 5% 1/10W
R1551	1-249-393-11	CARBON	10 5% 1/4W F
R1552	1-216-091-00	RES,CHIP	56K 5% 1/10W
R1553	1-216-091-00	RES,CHIP	56K 5% 1/10W
R1554	1-216-059-00	RES,CHIP	2.7K 5% 1/10W
R1555	1-216-295-91	SHORT	0
R1556	1-216-071-00	RES,CHIP	8.2K 5% 1/10W
R1557	1-218-760-11	METAL CHIP	220K 0.50% 1/10W
R1558	1-249-393-11	CARBON	10 5% 1/4W F
R1559	1-249-393-11	CARBON	10 5% 1/4W F

REF. NO.	PART NO.	DESCRIPTION	REMARK	REF. NO.	PART NO.	DESCRIPTION	REMARK
R1560	1-216-049-91	RES,CHIP	1K 5% 1/10W	R2352	1-216-061-00	RES,CHIP	3.3K 5% 1/10W
R1561	1-216-097-91	RES,CHIP	100K 5% 1/10W	R2353	1-216-041-00	RES,CHIP	470 5% 1/10W
R1562	1-216-089-91	RES,CHIP	47K 5% 1/10W	R2354	1-216-025-91	RES,CHIP	100 5% 1/10W
R1563	1-216-089-91	RES,CHIP	47K 5% 1/10W	R2358	1-216-025-91	RES,CHIP	100 5% 1/10W
R1565	1-216-113-00	RES,CHIP	470K 5% 1/10W	R2361	1-216-099-00	RES,CHIP	120K 5% 1/10W
R1567	1-216-089-91	RES,CHIP	47K 5% 1/10W	R2362	1-216-081-00	RES,CHIP	22K 5% 1/10W
R1570	1-216-073-00	RES,CHIP	10K 5% 1/10W	R2363	1-216-065-91	RES,CHIP	4.7K 5% 1/10W
R1571	1-216-103-00	RES,CHIP	180K 5% 1/10W	R2364	1-216-025-91	RES,CHIP	100 5% 1/10W
R1572	1-216-101-00	RES,CHIP	150K 5% 1/10W	R2365	1-216-687-11	METAL CHIP	33K 0.50% 1/10W
R1573	1-216-073-00	RES,CHIP	10K 5% 1/10W	R2366	1-216-067-00	RES,CHIP	5.6K 5% 1/10W
R1574	1-216-041-00	RES,CHIP	470 5% 1/10W	R2367	1-216-097-91	RES,CHIP	100K 5% 1/10W
R1575	1-216-025-91	RES,CHIP	100 5% 1/10W	R2368	1-216-065-91	RES,CHIP	4.7K 5% 1/10W
R1576	1-216-025-91	RES,CHIP	100 5% 1/10W	R2369	1-216-675-11	METAL CHIP	10K 0.50% 1/10W
R1577	1-216-025-91	RES,CHIP	100 5% 1/10W	R2371	1-216-049-91	RES,CHIP	1K 5% 1/10W
R1578	1-216-065-91	RES,CHIP	4.7K 5% 1/10W	R2372	1-216-113-00	RES,CHIP	470K 5% 1/10W
R1579	1-216-689-11	METAL CHIP	39K 0.50% 1/10W	R2374	1-216-097-91	RES,CHIP	100K 5% 1/10W
R1595	1-216-041-00	RES,CHIP	470 5% 1/10W	R2375	1-216-089-91	RES,CHIP	47K 5% 1/10W
R1596	1-216-099-00	RES,CHIP	120K 5% 1/10W	R2376	1-216-089-91	RES,CHIP	47K 5% 1/10W
R2300	1-216-065-91	RES,CHIP	4.7K 5% 1/10W	R2377	1-216-033-00	RES,CHIP	220 5% 1/10W
R2301	1-216-065-91	RES,CHIP	4.7K 5% 1/10W	R2378	1-216-089-91	RES,CHIP	47K 5% 1/10W
R2302	1-216-671-11	METAL CHIP	6.8K 0.50% 1/10W	R2379	1-216-033-00	RES,CHIP	220 5% 1/10W
R2303	1-216-093-00	RES,CHIP	68K 5% 1/10W	R2380	1-216-089-91	RES,CHIP	47K 5% 1/10W
R2304	1-216-105-91	RES,CHIP	220K 5% 1/10W	R2381	1-216-089-91	RES,CHIP	47K 5% 1/10W
R2305	1-216-085-00	RES,CHIP	33K 5% 1/10W	R2382	1-216-089-91	RES,CHIP	47K 5% 1/10W
R2306	1-216-089-91	RES,CHIP	47K 5% 1/10W	R2383	1-216-033-00	RES,CHIP	220 5% 1/10W
R2307	1-216-033-00	RES,CHIP	220 5% 1/10W	R2384	1-216-689-11	RES,CHIP	39K 5% 1/10W
R2308	1-216-103-00	RES,CHIP	180K 5% 1/10W	R2389	1-216-033-00	RES,CHIP	220 5% 1/10W
R2309	1-216-049-91	RES,CHIP	1K 5% 1/10W	R2390	1-216-647-11	METAL CHIP	680 0.50% 1/10W
R2310	1-216-095-00	RES,CHIP	82K 5% 1/10W	R2391	1-216-647-11	METAL CHIP	680 0.50% 1/10W
R2311	1-216-073-00	RES,CHIP	10K 5% 1/10W	R2392	1-216-073-00	RES,CHIP	10K 5% 1/10W
R2312	1-216-053-00	RES,CHIP	1.5K 5% 1/10W	R2393	1-216-073-00	RES,CHIP	10K 5% 1/10W
R2313	1-216-049-91	RES,CHIP	1K 5% 1/10W	R2394	1-216-081-00	RES,CHIP	22K 5% 1/10W
R2314	1-216-645-11	METAL CHIP	560 0.50% 1/10W	R2396	1-216-041-00	RES,CHIP	470 5% 1/10W
R2315	1-216-679-11	METAL CHIP	15K 0.50% 1/10W	R2397	1-216-113-00	RES,CHIP	470K 5% 1/10W
R2316	1-216-081-00	RES,CHIP	22K 5% 1/10W	R2398	1-216-109-00	RES,CHIP	330K 5% 1/10W
R2317	1-216-049-91	RES,CHIP	1K 5% 1/10W	R2399	1-216-073-00	RES,CHIP	10K 5% 1/10W
R2318	1-216-069-00	RES,CHIP	6.8K 5% 1/10W	R2501	1-216-083-00	RES,CHIP	27K 5% 1/10W
R2319	1-216-093-00	RES,CHIP	68K 5% 1/10W	R2502	1-216-085-00	RES,CHIP	33K 5% 1/10W
R2320	1-216-677-11	METAL CHIP	12K 0.50% 1/10W	R2503	1-216-097-91	RES,CHIP	100K 5% 1/10W
R2321	1-216-057-00	RES,CHIP	2.2K 5% 1/10W	R2504	1-216-101-00	RES,CHIP	150K 5% 1/10W
R2322	1-216-065-91	RES,CHIP	4.7K 5% 1/10W	R2505	1-216-113-00	RES,CHIP	470K 5% 1/10W
R2323	1-216-683-11	METAL CHIP	22K 0.50% 1/10W	R2506	1-216-099-00	RES,CHIP	120K 5% 1/10W
R2324	1-216-073-00	RES,CHIP	10K 5% 1/10W	R2507	1-216-105-91	RES,CHIP	220K 5% 1/10W
R2325	1-216-063-91	RES,CHIP	3.9K 5% 1/10W	R2551	1-216-091-00	RES,CHIP	56K 5% 1/10W
R2326	1-216-041-00	RES,CHIP	470 5% 1/10W	R2552	1-216-085-00	RES,CHIP	33K 5% 1/10W
R2327	1-216-059-00	RES,CHIP	2.7K 5% 1/10W	R2553	1-216-083-00	RES,CHIP	27K 5% 1/10W
R2328	1-216-049-91	RES,CHIP	1K 5% 1/10W	R2555	1-216-055-00	RES,CHIP	1.8K 5% 1/10W
R2329	1-216-059-00	RES,CHIP	2.7K 5% 1/10W	R2556	1-216-051-00	RES,CHIP	1.2K 5% 1/10W
R2330	1-216-049-91	RES,CHIP	1K 5% 1/10W	R2557	1-216-067-00	RES,CHIP	5.6K 5% 1/10W
R2331	1-216-059-00	RES,CHIP	2.7K 5% 1/10W	R2558	1-216-057-00	RES,CHIP	2.2K 5% 1/10W
R2332	1-216-049-91	RES,CHIP	1K 5% 1/10W	R2559	1-216-039-00	RES,CHIP	390 5% 1/10W
R2333	1-216-089-91	RES,CHIP	47K 5% 1/10W	R2560	1-216-069-00	RES,CHIP	6.8K 5% 1/10W
R2334	1-216-041-00	RES,CHIP	470 5% 1/10W	R2561	1-216-001-00	RES,CHIP	10 5% 1/10W
R2335	1-216-061-00	RES,CHIP	3.3K 5% 1/10W	R2562	1-216-001-00	RES,CHIP	10 5% 1/10W
R2336	1-216-065-91	RES,CHIP	4.7K 5% 1/10W	R2563	1-216-057-00	RES,CHIP	2.2K 5% 1/10W
R2337	1-216-037-00	RES,CHIP	330 5% 1/10W	R3301	1-216-073-00	RES,CHIP	10K 5% 1/10W
R2338	1-216-073-00	RES,CHIP	10K 5% 1/10W	R3302	1-216-065-91	RES,CHIP	4.7K 5% 1/10W
R2339	1-216-037-00	RES,CHIP	330 5% 1/10W	R3303	1-216-065-91	RES,CHIP	4.7K 5% 1/10W
R2341	1-216-037-00	RES,CHIP	330 5% 1/10W	R3304	1-216-065-91	RES,CHIP	4.7K 5% 1/10W
R2342	1-216-071-00	RES,CHIP	8.2K 5% 1/10W	R3308	1-216-097-91	RES,CHIP	100K 5% 1/10W
R2343	1-216-081-00	RES,CHIP	22K 5% 1/10W	R3310	1-216-049-91	RES,CHIP	1K 5% 1/10W
R2344	1-216-121-91	RES,CHIP	1M 5% 1/10W	R3311	1-216-689-11	RES,CHIP	39K 5% 1/10W
R2345	1-216-681-11	METAL CHIP	18K 0.50% 1/10W	R3312	1-216-095-00	RES,CHIP	82K 5% 1/10W
R2346	1-216-061-00	RES,CHIP	3.3K 5% 1/10W	R3317	1-216-675-11	METAL CHIP	10K 0.50% 1/10W
R2347	1-216-061-00	RES,CHIP	3.3K 5% 1/10W	R3320	1-216-085-00	RES,CHIP	33K 5% 1/10W
R2348	1-216-061-00	RES,CHIP	3.3K 5% 1/10W	R3323	1-216-089-91	RES,CHIP	47K 5% 1/10W
R2349	1-216-679-11	METAL CHIP	15K 0.50% 1/10W	R3333	1-216-113-00	RES,CHIP	470K 5% 1/10W
R2350	1-216-061-00	RES,CHIP	3.3K 5% 1/10W	R3334	1-216-073-00	RES,CHIP	10K 5% 1/10W
R2351	1-216-061-00	RES,CHIP	3.3K 5% 1/10W				



Les composants identifiés par une trame et une marque Δ sont critiques pour la sécurité. Ne les remplacer que par une pièce portant le numéro spécifique.

The components identified by shading and mark Δ are critical for safety. Replace only with part number specified.

REF. NO.	PART NO.	DESCRIPTION	REMARK
R3335	1-216-113-00	RES,CHIP	470K 5% 1/10W
R3336	1-216-045-00	RES,CHIP	680 5% 1/10W
R3337	1-216-099-00	RES,CHIP	120K 5% 1/10W
R3338	1-216-103-00	RES,CHIP	180K 5% 1/10W
R3339	1-216-045-00	RES,CHIP	680 5% 1/10W
R3346	1-216-025-91	RES,CHIP	100 5% 1/10W
R3347	1-216-025-91	RES,CHIP	100 5% 1/10W
R3348	1-216-025-91	RES,CHIP	100 5% 1/10W
R3349	1-216-025-91	RES,CHIP	100 5% 1/10W
R3350	1-216-109-00	RES,CHIP	330K 5% 1/10W
R3351	1-216-115-00	RES,CHIP	560K 5% 1/10W
R3353	1-216-111-91	RES,CHIP	390K 5% 1/10W
R3355	1-216-089-91	RES,CHIP	47K 5% 1/10W
R3356	1-216-051-00	RES,CHIP	1.2K 5% 1/10W
R3357	1-216-051-00	RES,CHIP	1.2K 5% 1/10W
R3358	1-216-051-00	RES,CHIP	1.2K 5% 1/10W
R3359	1-216-081-00	RES,CHIP	22K 5% 1/10W
R3360	1-216-073-00	RES,CHIP	10K 5% 1/10W
R3361	1-216-089-91	RES,CHIP	47K 5% 1/10W
R3362	1-216-049-91	RES,CHIP	1K 5% 1/10W
R3363	1-216-049-91	RES,CHIP	1K 5% 1/10W
R3364	1-216-073-00	RES,CHIP	10K 5% 1/10W
R3365	1-216-099-00	RES,CHIP	120K 5% 1/10W
R3366	1-216-093-00	RES,CHIP	68K 5% 1/10W
R3367	1-216-093-00	RES,CHIP	68K 5% 1/10W
R3368	1-216-081-00	RES,CHIP	22K 5% 1/10W
R3369	1-216-089-91	RES,CHIP	47K 5% 1/10W
R3376	1-216-081-00	RES,CHIP	22K 5% 1/10W
R3378	1-216-119-00	RES,CHIP	820K 5% 1/10W
R3380	1-216-121-91	RES,CHIP	1M 5% 1/10W
R3390	1-216-057-00	RES,CHIP	2.2K 5% 1/10W
R3394	1-216-089-91	RES,CHIP	47K 5% 1/10W
R3395	1-216-049-91	RES,CHIP	1K 5% 1/10W
R3396	1-216-041-00	RES,CHIP	470 5% 1/10W
R3398	1-216-688-11	METAL CHIP	36K 0.50% 1/10W
R3399	1-216-025-91	RES,CHIP	100 5% 1/10W
R3400	1-216-091-00	RES,CHIP	56K 5% 1/10W
R3401	1-216-061-00	RES,CHIP	3.3K 5% 1/10W
R3402	1-216-699-11	METAL CHIP	100K 0.50% 1/10W
R3403	1-216-025-91	RES,CHIP	100 5% 1/10W
R3404	1-216-073-00	RES,CHIP	10K 5% 1/10W
R3405	1-216-067-00	RES,CHIP	5.6K 5% 1/10W
R3406	1-216-073-00	RES,CHIP	10K 5% 1/10W
R3407	1-216-073-00	RES,CHIP	10K 5% 1/10W
R4401	1-216-085-00	RES,CHIP	33K 5% 1/10W
R4404	1-216-073-00	RES,CHIP	10K 5% 1/10W
R4405	1-216-069-00	RES,CHIP	6.8K 5% 1/10W
R4407	1-216-061-00	RES,CHIP	3.3K 5% 1/10W
R4408	1-216-059-00	RES,CHIP	2.7K 5% 1/10W
R4409	1-216-059-00	RES,CHIP	2.7K 5% 1/10W
R4410	1-216-059-00	RES,CHIP	2.7K 5% 1/10W
R4411	1-216-113-00	RES,CHIP	470K 5% 1/10W
R4412	1-216-113-00	RES,CHIP	470K 5% 1/10W
R4413	1-216-295-91	SHORT	0
R4414	1-216-295-91	SHORT	0
R4415	1-216-295-91	SHORT	0
R4416	1-216-295-91	SHORT	0
<VARIABLE RESISTOR>			
RV501	1-223-102-00	RES, ADJ, WIREWOUND 120	
<TRANSFORMER>			
T500	1-426-668-11	TRANSFORMER, FERRITE (HDT)	
T501	Δ 1-453-234-11	TRANSFORMER ASSY, FLYBACK	
T502	1-413-059-00	TRANSFORMER, FERRITE (DFT)	
T503	Δ 1-466-017-11	TRANSFORMER	

REF. NO.	PART NO.	DESCRIPTION	REMARK
<THERMISTOR>			
TH500	1-807-970-11	THERMISTOR	
<CRYSTAL>			
X101	1-579-175-11	VIBRATOR, CERAMIC	
X300	1-577-259-11	VIBRATOR, CRYSTAL	
X301	1-527-722-00	VIBRATOR, CRYSTAL	

* A-1304-141-A M BOARD, COMPLETE			

1-540-044-11 SOCKET, IC			
<CAPACITOR>			
C1200	1-124-472-11	ELECT 470MF	20% 10V
C1201	1-164-161-11	CERAMIC CHIP 0.0022MF	10% 50V
C1202	1-164-161-11	CERAMIC CHIP 0.0022MF	10% 50V
C1203	1-163-103-00	CERAMIC CHIP 27PF	5% 50V
C1204	1-163-103-00	CERAMIC CHIP 27PF	5% 50V
C1205	1-164-346-11	CERAMIC CHIP 1MF	16V
C1208	1-164-346-11	CERAMIC CHIP 1MF	16V
C1210	1-104-665-11	ELECT 100MF	20% 16V
C1211	1-164-346-11	CERAMIC CHIP 1MF	16V
C1213	1-126-301-11	ELECT 1MF	20% 50V
C1214	1-126-301-11	ELECT 1MF	20% 50V
C1215	1-126-301-11	ELECT 1MF	20% 50V
C1216	1-126-301-11	ELECT 1MF	20% 50V
C1219	1-163-123-00	CERAMIC CHIP 180PF	5% 50V
C1220	1-163-123-00	CERAMIC CHIP 180PF	5% 50V
<CONNECTOR>			
CN1201	* 1-766-746-11	CONNECTOR, BOARD TO BOARD 12P	
CN1202	* 1-564-506-11	PLUG, CONNECTOR 3P	
<IC>			
IC1201	* 8-759-498-23	IC μ PD78P018FYCW-S02	
IC1202	8-759-251-04	IC AT24C02-10PC	
IC1203	8-759-149-05	IC μ PD71051GB-10-3B4	
IC1204	8-759-335-70	IC ADM232LAR-REEL	
IC1205	8-759-042-02	IC S-80743AL-A7-S	
<CHIP CONDUCTOR>			
JR1	1-216-295-91	SHORT	0
JR2	1-216-295-91	SHORT	0
JR3	1-216-295-91	SHORT	0
JR4	1-216-295-91	SHORT	0
JR5	1-216-295-91	SHORT	0
JR6	1-216-295-91	SHORT	0
JR7	1-216-295-91	SHORT	0
JR8	1-216-295-91	SHORT	0
<RESISTOR>			
R1201	1-216-073-00	RES,CHIP	10K 5% 1/10W
R1202	1-216-295-91	SHORT	0
R1203	1-216-065-91	RES,CHIP	4.7K 5% 1/10W
R1204	1-216-065-91	RES,CHIP	4.7K 5% 1/10W
R1205	1-216-065-91	RES,CHIP	4.7K 5% 1/10W
R1206	1-216-295-91	SHORT	0
R1207	1-216-295-91	SHORT	0
R1210	1-216-025-91	RES,CHIP	100 5% 1/10W
R1211	1-216-025-91	RES,CHIP	100 5% 1/10W

The components identified by shading and mark Δ are critical for safety. Replace only with part number specified.

Les composants identifiés par une trame et une marque Δ sont critiques pour la sécurité. Ne les remplacer que par une pièce portant le numéro spécifié.



REF. NO.	PART NO.	DESCRIPTION	REMARK
R1213	1-216-025-91	RES,CHIP 100 5%	1/10W
R1214	1-216-295-91	SHORT 0	
R1215	1-216-295-91	SHORT 0	
R1218	1-216-089-91	RES,CHIP 47K 5%	1/10W
R1220	1-216-025-91	RES,CHIP 100 5%	1/10W
R1221	1-216-025-91	RES,CHIP 100 5%	1/10W

<CRYSTAL>

X1201	1-577-619-11	VIBRATOR, CRYSTAL	
-------	--------------	-------------------	--

* A-1316-349-A G BOARD, COMPLETE

1-533-223-11 HOLDER, FUSE
7-322-065-19 RUBBER, SILICON RTV (KE490W)

<CAPACITOR>

C602	Δ 1-136-360-51	FILM 0.22MF 20%	250V
C603	Δ 1-136-360-51	FILM 0.22MF 20%	250V
C604	Δ 1-113-924-91	CERAMIC 0.0047MF 20%	250V
* 4-374-846-11 COVER, CAPACITOR, CAP TYPE ; C604			
C605	Δ 1-113-924-91	CERAMIC 0.0047MF 20%	250V
C606	Δ 1-113-924-91	CERAMIC 0.0047MF 20%	250V

C607	Δ 1-113-924-91	CERAMIC 0.0047MF 20%	250V
* 4-374-846-11 COVER, CAPACITOR, CAP TYPE ; C607			
C608	Δ 1-113-924-91	CERAMIC 0.0047MF 20%	250V
C609	Δ 1-113-924-91	CERAMIC 0.0047MF 20%	250V
C610	Δ 1-113-924-91	CERAMIC 0.0047MF 20%	250V
C611	Δ 1-113-924-91	CERAMIC 0.0047MF 20%	250V

C612	Δ 1-113-977-51	FILM 0.47MF 10%	630V
C613	Δ 1-113-977-51	FILM 0.47MF 10%	630V
C614	Δ 1-129-718-91	FILM 0.022MF 5%	630V
C615	Δ 1-136-619-11	FILM 0.0016MF 3%	2KV
C616	Δ 1-104-962-91	ELECT 47MF 20%	35V

C617	Δ 1-107-430-91	CERAMIC 0.0033MF 10%	1KV
C618	Δ 1-107-906-91	ELECT 10MF 20%	50V
C619	Δ 1-107-911-91	ELECT 220MF 20%	50V
C621	1-117-791-11	ELECT(BLOCK) 1000MF 20%	160V
C622	1-102-038-00	CERAMIC 0.001MF	500V

C623	1-107-900-51	ELECT 4700MF 20%	35V
C626	1-102-038-00	CERAMIC 0.001MF	500V
C627	1-107-900-51	ELECT 4700MF 20%	35V
C628	1-102-038-00	CERAMIC 0.001MF	500V
C629	1-107-891-11	ELECT 3300MF 20%	25V

C630	1-126-964-11	ELECT 10MF 20%	50V
C631	1-136-853-11	FILM 0.56MF 5%	200V
C632	1-107-492-11	ELECT 47MF 20%	160V
C633	1-107-885-11	ELECT 3300MF 20%	16V
C635	Δ 1-162-115-91	CERAMIC 330PF 10%	2KV

C636	1-107-909-11	ELECT 47MF 20%	50V
C638	Δ 1-113-977-51	FILM 0.47MF 10%	630V
C639	1-107-906-11	ELECT 10MF 20%	50V
C640	1-107-906-11	ELECT 10MF 20%	50V
C641	1-102-074-00	CERAMIC 0.001MF 10%	50V

C2601	1-102-038-00	CERAMIC 0.001MF	500V
-------	--------------	-----------------	------

<CONNECTOR>

CN601	* 1-580-843-11	PIN, CONNECTOR (POWER)
CN602	* 1-695-561-11	PIN, CONNECTOR (PC BOARD) 7P
CN603	* 1-508-765-00	PIN, CONNECTOR (5mm PITCH) 3P
CN605	* 1-573-964-11	PIN, CONNECTOR (PC BOARD) 6P
CN606	* 1-564-506-11	PLUG, CONNECTOR 3P

CN607	* 1-564-509-11	PLUG, CONNECTOR 6P
-------	----------------	--------------------

REF. NO.	PART NO.	DESCRIPTION	REMARK
CN609	1-508-786-00	PIN, CONNECTOR (5mm PITCH) 2P	

<DIODE>

D601	Δ 8-719-510-53	DIODE D4SB60L
	4-382-854-11	SCREW (M3X10), P, SW (+) ; D601
D605	Δ 8-719-971-66	DIODE RGP151-6040G23
D606	Δ 8-719-988-56	DIODE RGP15K-6179G23
D607	Δ 8-719-936-85	DIODE RGP10GPKG23
D608	Δ 8-719-921-20	DIODE 1SS119-25TD

D609	Δ 8-719-936-85	DIODE RGP10GPKG23
D610	8-719-029-04	DIODE D5L60
	4-382-854-11	SCREW (M3X10), P, SW (+) ; D610
D612	8-719-312-08	DIODE FMB-G16L
	4-382-854-11	SCREW (M3X10), P, SW (+) ; D612
D614	8-719-045-48	DIODE FML-G12S
	4-382-854-11	SCREW (M3X10), P, SW (+) ; D614
D615	8-719-979-85	DIODE EGP20G

D616	8-719-054-32	DIODE ERA15-06
D617	8-719-110-46	DIODE RD16ESB3
D618	Δ 8-719-971-66	DIODE RGP151-6040G23
D619	Δ 8-719-113-43	DIODE RD20ES-T1B2
D620	Δ 8-719-936-85	DIODE RGP10GPKG23

D621	8-719-911-19	DIODE 1SS119-25
------	--------------	-----------------

<FERRITE BEAD>

FB603	1-410-396-41	FERRITE 0.45UH
FB604	1-410-396-41	FERRITE 0.45UH
FB605	1-410-396-41	FERRITE 0.45UH
FB608	Δ 1-410-397-31	FERRITE 1.1UH
FB609	Δ 1-410-397-31	FERRITE 1.1UH

FB610	Δ 1-410-397-31	FERRITE 1.1UH
FB611	Δ 1-410-397-31	FERRITE 1.1UH
FB612	Δ 1-410-397-31	FERRITE 1.1UH
FB613	Δ 1-410-397-31	FERRITE 1.1UH

<IC>

IC601	Δ 8-749-925-03	IC STR-M6524
	4-058-250-01	SHEET, INSULATING ; IC601
	4-382-854-11	SCREW (M3X10), P, SW (+) ; IC601
IC602	8-749-010-47	IC STR-S3115
	4-382-854-11	SCREW (M3X10), P, SW (+) ; IC602
IC603	8-759-701-56	IC NJM78M05FA
	4-382-854-11	SCREW (M3X10), P, SW (+) ; IC603

<COIL>

L601	Δ 1-411-215-11	INDUCTOR 0UH
L1601	1-410-679-31	INDUCTOR 270UH
L2601	1-459-155-00	COIL (WITH CORE) 45UH

<PHOTO COUPLER>

PH601	Δ 8-749-923-50	PHOTO COUPLER PC111YS
-------	-----------------------	-----------------------

<TRANSISTOR>

Q601	8-729-140-96	TRANSISTOR 2SD774-34
Q602	Δ 8-729-023-28	TRANSISTOR 2SD1640C
Q603	8-729-303-61	TRANSISTOR 2SC3851-G
	4-382-854-11	SCREW (M3X10), P, SW (+) ; Q603
Q604	8-729-029-66	TRANSISTOR DTC114ESA
Q605	8-729-200-17	TRANSISTOR 2SA1091-O

Q606	8-729-029-66	TRANSISTOR DTC114ESA
Q607	8-729-029-66	TRANSISTOR DTC114ESA



Les composants identifiés par une trame et une marque Δ sont critiques pour la sécurité. Ne les remplacer que par une pièce portant le numéro spécifié.

The components identified by shading and mark Δ are critical for safety. Replace only with part number specified.

REF. NO.	PART NO.	DESCRIPTION	REMARK
<RESISTOR>			
R601	Δ 1-202-885-91	SOLID 1M 20% 1/2W	
R602	Δ 1-216-491-71	METAL OXIDE 56K 5% 3W F	
R603	Δ 1-216-490-71	METAL OXIDE 39K 5% 3W F	
R604	Δ 1-247-833-91	CARBON 1.2K 5% 1/4W	
R605	Δ 1-247-833-91	CARBON 1.2K 5% 1/4W	
R606	Δ 1-217-239-11	WIREWOUND 0.15 10% 3W F	
R607	Δ 1-247-849-91	CARBON 5.6K 5% 1/4W	
R608	Δ 1-247-857-91	CARBON 12K 5% 1/4W	
R609	Δ 1-247-857-91	CARBON 12K 5% 1/4W	
R610	Δ 1-247-853-91	CARBON 8.2K 5% 1/4W	
R611	Δ 1-249-417-91	CARBON 1K 5% 1/4W F	
R612	1-249-404-00	CARBON 82 5% 1/4W	
R613	Δ 1-247-833-91	CARBON 1.5K 5% 1/4W	
R614	Δ 1-249-385-91	CARBON 2.2 5% 1/4W F	
R615	Δ 1-202-727-91	SOLID 4.7M 10% 1/2W	
R616	Δ 1-247-863-91	CARBON 22K 5% 1/4W	
R617	1-202-933-61	FUSIBLE 0.1 10% 1/2W F	
R619	1-202-933-61	FUSIBLE 0.1 10% 1/2W F	
R620	1-202-933-61	FUSIBLE 0.1 10% 1/2W F	
R621	1-215-877-11	METAL OXIDE 22K 5% 1W F	
R622	1-249-401-11	CARBON 47 5% 1/4W F	
R623	1-249-417-11	CARBON 1K 5% 1/4W	
R624	1-247-893-11	CARBON 390K 5% 1/4W	
R625	1-216-386-11	METAL OXIDE 0.56 5% 3W F	
R627	Δ 1-216-490-71	METAL OXIDE 39K 5% 3W F	
R628	Δ 1-216-491-71	METAL OXIDE 56K 5% 3W F	
R629	Δ 1-202-727-91	SOLID 4.7M 10% 1/2W	
R630	Δ 1-216-490-71	METAL OXIDE 39K 5% 3W F	
R631	1-249-415-11	CARBON 680 5% 1/4W F	
R632	1-249-401-11	CARBON 47 5% 1/4W F	
R633	1-249-429-11	CARBON 10K 5% 1/4W	
R634	1-247-883-00	CARBON 150K 5% 1/4W	
R635	1-249-429-11	CARBON 10K 5% 1/4W	
R636	1-247-895-91	CARBON 470K 5% 1/4W	
R637	1-249-424-11	CARBON 3.9K 5% 1/4W	
R638	1-249-417-11	CARBON 1K 5% 1/4W	
R639	1-249-419-11	CARBON 1.5K 5% 1/4W	
R640	1-247-893-11	CARBON 390K 5% 1/4W	
R641	1-215-423-00	METAL 1.2K 1% 1/4W	
R642	1-216-391-11	METAL OXIDE 1.5 5% 3W F	
R1602	Δ 1-202-878-91	SOLID 220K 20% 1/2W	
R1603	Δ 1-202-878-91	SOLID 220K 20% 1/2W	
<RELAY>			
RY601	Δ 1-515-738-11	RELAY	
<TRANSFORMER>			
T601	Δ 1-426-716-11	TRANSFORMER, LINE FILTER (LFT)	
T602	Δ 1-426-716-11	TRANSFORMER, LINE FILTER (LFT)	
T603	Δ 1-431-630-11	TRANSFORMER, CONVERTER (SRT)	
<THERMISTOR>			
THP601	Δ 1-808-059-32	THERMISTOR, POSITIVE	
<VARISTOR>			
VDR601	Δ 1-809-942-81	VARISTOR	
VDR602	Δ 1-809-942-81	VARISTOR	

REF. NO.	PART NO.	DESCRIPTION	REMARK
* A-1316-350-A GA BOARD, COMPLETE *****			
	1-533-223-11	HOLDER, FUSE	
	4-382-854-11	SCREW (M3X10), P, SW (+)	
<CAPACITOR>			
C1601	1-107-910-11	ELECT 100MF 20% 50V	
C1602	1-107-911-11	ELECT 220MF 20% 50V	
<CONNECTOR>			
CN1601	* 1-564-509-11	PLUG, CONNECTOR 6P	
<IC>			
IC1601	8-759-390-50	IC uPC2408AHF	
<RESISTOR>			
R1604	1-247-895-91	CARBON 470K 5% 1/4W	

* A-1331-763-A C BOARD, COMPLETE (20inch model) *****			
	7-682-949-01	SCREW +PSW 3X10	
<CAPACITOR>			
C701	1-102-116-00	CERAMIC 680PF 10% 50V	
C702	1-102-116-00	CERAMIC 680PF 10% 50V	
C703	1-102-116-00	CERAMIC 680PF 10% 50V	
C704	1-102-121-00	CERAMIC 0.0022MF 10% 50V	
C705	1-126-933-11	ELECT 100MF 20% 16V	
C706	1-102-074-00	CERAMIC 0.001MF 10% 50V	
C707	1-162-116-00	CERAMIC 680PF 10% 2KV	
C708	1-136-601-11	FILM 0.01MF 10% 630V	
C710	1-101-880-00	CERAMIC 47PF 5% 50V	
C711	1-101-880-00	CERAMIC 47PF 5% 50V	
C712	1-101-880-00	CERAMIC 47PF 5% 50V	
C714	1-102-976-00	CERAMIC 180PF 5% 50V	
C715	1-102-976-00	CERAMIC 180PF 5% 50V	
C716	1-102-976-00	CERAMIC 180PF 5% 50V	
C724	1-128-582-11	ELECT 10MF 20% 100V	
C726	1-107-662-11	ELECT 22MF 20% 250V	
C733	1-107-652-11	ELECT 10MF 20% 250V	
C734	1-101-888-00	CERAMIC 68PF 5% 50V	
C737	1-102-934-00	CERAMIC 1PF 0.25PF 50V	
<CONNECTOR>			
CN701	* 1-564-511-11	PLUG, CONNECTOR 8P	
CN702	* 1-573-964-11	PIN, CONNECTOR (PC BOARD) 6P	
CN703	1-695-915-11	TAB (CONTACT)	
<DIODE>			
D701	8-719-911-19	DIODE 1SS119-25	
D702	8-719-911-19	DIODE 1SS119-25	
D703	8-719-911-19	DIODE 1SS119-25	
D704	8-719-911-19	DIODE 1SS119-25	
D705	8-719-911-19	DIODE 1SS119-25	
D706	8-719-911-19	DIODE 1SS119-25	
D707	8-719-901-83	DIODE 1SS83	
D708	8-719-901-83	DIODE 1SS83	
D709	8-719-901-83	DIODE 1SS83	

The components identified by shading and mark Δ are critical for safety. Replace only with part number specified.

Les composants identifiés par une trame et une marque Δ sont critiques pour la sécurité. Ne les remplacer que par une pièce portant le numéro spécifié.



REF. NO.	PART NO.	DESCRIPTION	REMARK	REF. NO.	PART NO.	DESCRIPTION	REMARK
D713	8-719-901-83	DIODE 1SS83		R738	1-247-807-31	CARBON 100 5%	1/4W
D715	8-719-901-83	DIODE 1SS83		R739	1-247-807-31	CARBON 100 5%	1/4W
D716	8-719-901-83	DIODE 1SS83		R740	1-249-433-11	CARBON 22K 5%	1/4W F
D717	8-719-901-83	DIODE 1SS83		R741	1-249-433-11	CARBON 22K 5%	1/4W F
<JACK>				R742	1-249-433-11	CARBON 22K 5%	1/4W F
L701	Δ 1-540-124-11	SOCKET, PICTURE TUBE		R744	1-247-843-11	CARBON 3.3K 5%	1/4W
<COIL>				R745	1-249-429-11	CARBON 10K 5%	1/4W
L702	1-408-607-31	INDUCTOR 22UH		R746	1-215-879-11	METAL OXIDE 47K 5%	1W F
L703	1-408-608-31	INDUCTOR 27UH		R747	1-247-725-11	CARBON 10K 5%	1/4W F
L704	1-408-608-31	INDUCTOR 27UH		R748	1-249-923-11	CARBON 1K 5%	1/4W F
L705	1-412-530-31	INDUCTOR 27UH		R749	1-215-902-11	METAL OXIDE 47K 5%	2W F
L706	1-410-667-31	INDUCTOR 22UH		R751	1-247-887-00	CARBON 220K 5%	1/4W
<TRANSISTOR>				R752	1-247-887-00	CARBON 220K 5%	1/4W
Q701	8-729-119-78	TRANSISTOR 2SC2785-HFE		R753	1-247-887-00	CARBON 220K 5%	1/4W
Q702	8-729-119-78	TRANSISTOR 2SC2785-HFE		R754	1-247-863-91	CARBON 22K 5%	1/4W
Q703	8-729-119-78	TRANSISTOR 2SC2785-HFE		R755	1-249-434-11	CARBON 27K 5%	1/4W
Q704	8-729-200-17	TRANSISTOR 2SA1091-O		R756	1-249-440-11	CARBON 82K 5%	1/4W
Q705	8-729-200-17	TRANSISTOR 2SA1091-O		R760	1-249-400-11	CARBON 39 5%	1/4W F
Q706	8-729-200-17	TRANSISTOR 2SA1091-O		<VARIABLE RESISTOR>			
Q707	8-729-326-11	TRANSISTOR 2SC2611		RV708	Δ 1-241-714-21	RES. ADJ. METAL FILM 110M	
Q708	8-729-326-11	TRANSISTOR 2SC2611		RV709	1-230-641-11	RES. ADJ. METAL GLAZE 2.2M	
Q709	8-729-326-11	TRANSISTOR 2SC2611		*****			
Q710	8-729-200-17	TRANSISTOR 2SA1091-O		* A-1331-764-A C BOARD, COMPLETE (14inch model)			
Q711	8-729-200-17	TRANSISTOR 2SA1091-O		*****			
Q712	8-729-200-17	TRANSISTOR 2SA1091-O		* 4-374-913-01 COVER (REAR LID), CV VOL			
Q713	8-729-255-12	TRANSISTOR 2SC2551-O		7-682-949-01 SCREW +PSW 3X10			
Q714	8-729-255-12	TRANSISTOR 2SC2551-O		<CAPACITOR>			
Q715	8-729-255-12	TRANSISTOR 2SC2551-O		C701	1-102-157-00	CERAMIC 560PF 10%	500V
Q716	8-729-255-12	TRANSISTOR 2SC2551-O		C702	1-102-157-00	CERAMIC 560PF 10%	500V
Q717	8-729-255-12	TRANSISTOR 2SC2551-O		C703	1-102-157-00	CERAMIC 560PF 10%	500V
<RESISTOR>				C704	1-102-121-00	CERAMIC 0.0022MF 10%	50V
R702	1-249-441-11	CARBON 100K 5%	1/4W	C705	1-126-933-11	ELECT 100MF 20%	16V
R704	1-215-404-00	METAL 200 1%	1/4W	C706	1-102-074-00	CERAMIC 0.001MF 10%	50V
R705	1-215-404-00	METAL 200 1%	1/4W	C707	1-162-116-00	CERAMIC 680PF 10%	2KV
R706	1-215-404-00	METAL 200 1%	1/4W	C708	1-136-601-11	FILM 0.01MF 5%	630V
R707	1-249-429-11	CARBON 10K 5%	1/4W	C710	1-101-880-00	CERAMIC 47PF 5%	50V
R708	1-249-429-11	CARBON 10K 5%	1/4W	C711	1-101-880-00	CERAMIC 47PF 5%	50V
R709	1-249-429-11	CARBON 10K 5%	1/4W	C712	1-101-880-00	CERAMIC 47PF 5%	50V
R710	1-215-388-00	METAL 43 1%	1/4W	C713	1-107-651-11	ELECT 4.7MF 20%	250V
R711	1-215-390-00	METAL 51 1%	1/4W	C714	1-102-976-00	CERAMIC 180PF 5%	50V
R712	1-215-388-00	METAL 43 1%	1/4W	C715	1-102-976-00	CERAMIC 180PF 5%	50V
R715	1-202-818-00	SOLID 1K 20%	1/2W	C716	1-102-976-00	CERAMIC 180PF 5%	50V
R716	1-216-486-00	METAL OXIDE 8.2K 5%	3W F	C717	1-107-372-11	MYLAR 0.22MF 10%	200V
R717	1-202-818-00	SOLID 1K 20%	1/2W	C718	1-107-372-11	MYLAR 0.22MF 10%	200V
R718	1-216-486-00	METAL OXIDE 8.2K 5%	3W F	C720	1-106-383-00	MYLAR 0.047MF 10%	200V
R719	1-202-818-00	SOLID 1K 20%	1/2W	C734	1-102-973-00	CERAMIC 100PF 5%	50V
R720	1-216-486-00	METAL OXIDE 8.2K 5%	3W F	C735	1-102-816-00	CERAMIC 120PF 5%	50V
R722	1-202-883-11	SOLID 680K 20%	1/2W	C736	1-102-816-00	CERAMIC 120PF 5%	50V
R723	1-202-838-00	SOLID 100K 20%	1/2W	<CONNECTOR>			
R724	1-202-842-11	SOLID 220K 20%	1/2W	CN701	* 1-564-511-11	PLUG, CONNECTOR 8P	
R725	1-202-838-00	SOLID 100K 20%	1/2W	CN702	* 1-573-964-11	PIN, CONNECTOR (PC BOARD) 6P	
R726	1-202-846-00	SOLID 470K 20%	1/2W	CN703	1-695-915-11	TAB (CONTACT)	
R728	1-202-837-00	SOLID 82K 20%	1/2W	<DIODE>			
R729	1-202-549-00	SOLID 100 20%	1/2W	D701	8-719-911-19	DIODE 1SS119-25	
R731	1-247-815-91	CARBON 220 5%	1/4W	D702	8-719-911-19	DIODE 1SS119-25	
R732	1-247-815-91	CARBON 220 5%	1/4W	D703	8-719-911-19	DIODE 1SS119-25	
R733	1-247-815-91	CARBON 220 5%	1/4W	D704	8-719-911-19	DIODE 1SS119-25	
R734	1-249-409-11	CARBON 220 5%	1/4W F	D705	8-719-911-19	DIODE 1SS119-25	
R735	1-249-409-11	CARBON 220 5%	1/4W F				
R736	1-249-409-11	CARBON 220 5%	1/4W F				
R737	1-247-807-31	CARBON 100 5%	1/4W				



Les composants identifiés par une trame et une marque Δ sont critiques pour la sécurité. Ne les remplacer que par une pièce portant le numéro spécifié.

The components identified by shading and mark Δ are critical for safety. Replace only with part number specified.

REF. NO.	PART NO.	DESCRIPTION	REMARK
D706	8-719-911-19	DIODE 1SS119-25	
D707	8-719-901-83	DIODE 1SS83	
D708	8-719-901-83	DIODE 1SS83	
D709	8-719-901-83	DIODE 1SS83	
D713	8-719-901-83	DIODE 1SS83	
D715	8-719-901-83	DIODE 1SS83	
D716	8-719-901-83	DIODE 1SS83	
D717	8-719-901-83	DIODE 1SS83	
<JACK>			
1701	A 1-526-819-11	SOCKET PICTURE TUBE	
<COIL>			
L701	1-410-667-31	INDUCTOR 22UH	
L705	1-412-532-11	INDUCTOR 39UH	
<TRANSISTOR>			
Q701	8-729-119-78	TRANSISTOR 2SC2785-HFE	
Q702	8-729-119-78	TRANSISTOR 2SC2785-HFE	
Q703	8-729-119-78	TRANSISTOR 2SC2785-HFE	
Q704	8-729-200-17	TRANSISTOR 2SA1091-O	
Q705	8-729-200-17	TRANSISTOR 2SA1091-O	
Q706	8-729-200-17	TRANSISTOR 2SA1091-O	
Q707	8-729-326-11	TRANSISTOR 2SC2611	
Q708	8-729-326-11	TRANSISTOR 2SC2611	
Q709	8-729-326-11	TRANSISTOR 2SC2611	
Q710	8-729-200-17	TRANSISTOR 2SA1091-O	
Q711	8-729-200-17	TRANSISTOR 2SA1091-O	
Q712	8-729-200-17	TRANSISTOR 2SA1091-O	
Q713	8-729-255-12	TRANSISTOR 2SC2551-O	
Q714	8-729-255-12	TRANSISTOR 2SC2551-O	
Q715	8-729-119-78	TRANSISTOR 2SC2785-HFE	
Q716	8-729-119-78	TRANSISTOR 2SC2785-HFE	
Q717	8-729-119-78	TRANSISTOR 2SC2785-HFE	
<RESISTOR>			
R702	1-247-897-11	CARBON	560K 5% 1/4W
R704	1-215-405-00	METAL	220 1% 1/4W
R705	1-215-405-00	METAL	220 1% 1/4W
R706	1-215-405-00	METAL	220 1% 1/4W
R707	1-249-431-11	CARBON	15K 5% 1/4W
R708	1-249-431-11	CARBON	15K 5% 1/4W
R709	1-249-431-11	CARBON	15K 5% 1/4W
R710	1-215-391-00	METAL	56 1% 1/4W
R711	1-215-394-00	METAL	75 1% 1/4W
R712	1-215-392-00	METAL	62 1% 1/4W
R715	1-202-818-00	SOLID	1K 20% 1/2W
R716	1-216-486-00	METAL OXIDE	8.2K 5% 3W F
R717	1-202-818-00	SOLID	1K 20% 1/2W
R718	1-216-486-00	METAL OXIDE	8.2K 5% 3W F
R719	1-202-818-00	SOLID	1K 20% 1/2W
R720	1-216-486-00	METAL OXIDE	8.2K 5% 3W F
R722	1-202-883-11	SOLID	680K 20% 1/2W
R723	1-202-838-00	SOLID	100K 20% 1/2W
R724	1-202-842-11	SOLID	220K 20% 1/2W
R725	1-202-719-00	SOLID	1M 20% 1/2W
R731	1-247-815-91	CARBON	220 5% 1/4W
R732	1-247-815-91	CARBON	220 5% 1/4W
R733	1-247-815-91	CARBON	220 5% 1/4W
R734	1-249-409-11	CARBON	220 5% 1/4W F
R735	1-249-409-11	CARBON	220 5% 1/4W F
R736	1-249-409-11	CARBON	220 5% 1/4W F
R737	1-247-807-31	CARBON	100 5% 1/4W
R738	1-247-807-31	CARBON	100 5% 1/4W
R739	1-247-807-31	CARBON	100 5% 1/4W

REF. NO.	PART NO.	DESCRIPTION	REMARK
R740	1-249-429-11	CARBON	10K 5% 1/4W F
R741	1-249-429-11	CARBON	10K 5% 1/4W F
R742	1-249-429-11	CARBON	10K 5% 1/4W F
R744	1-249-429-11	CARBON	10K 5% 1/4W
R745	1-249-429-11	CARBON	10K 5% 1/4W
R746	1-215-879-11	METAL OXIDE	47K 5% 1W F
R747	1-247-725-11	CARBON	10K 5% 1/4W F
R748	1-249-923-11	CARBON	1K 5% 1/4W F
R749	1-215-902-11	METAL OXIDE	47K 5% 2W F
R750	1-249-400-11	CARBON	39 5% 1/4W F
R751	1-247-887-00	CARBON	220K 5% 1/4W
R752	1-247-887-00	CARBON	220K 5% 1/4W
R753	1-247-887-00	CARBON	220K 5% 1/4W
<VARIABLE RESISTOR>			
RV707	1-230-641-11	RES. ADJ. METAL GLAZE 2.2M	
RV708	Δ 1-230-619-11	RES. ADJ. METAL GLAZE 110M	
	* 4-374-912-01	COVER (MAIN), CV VOL ; RV708	
RV709	1-230-641-11	RES. ADJ. METAL GLAZE 2.2M	

	* A-1372-410-A	H BOARD, COMPLETE	
	* 4-348-208-00	HOLDER, LED	
<CONNECTOR>			
CN105	* 1-564-527-11	PLUG, CONNECTOR 12P	
CN106	* 1-564-526-11	PLUG, CONNECTOR 11P	
<DIODE>			
D2102	8-719-920-05	DIODE SLP281C-50	
D2103	8-719-812-32	DIODE TLY123	
D2104	8-719-991-33	DIODE 1SS133T-77	
<RESISTOR>			
R2101	1-249-419-11	CARBON	1.5K 5% 1/4W
R2107	1-249-430-11	CARBON	12K 5% 1/4W
R2137	1-249-414-11	CARBON	560 5% 1/4W
R2138	1-249-414-11	CARBON	560 5% 1/4W
R2140	1-249-414-11	CARBON	560 5% 1/4W
R2141	1-249-414-11	CARBON	560 5% 1/4W
R2142	1-249-414-11	CARBON	560 5% 1/4W
R2143	1-249-414-11	CARBON	560 5% 1/4W
R2144	1-249-414-11	CARBON	560 5% 1/4W
R2145	1-249-414-11	CARBON	560 5% 1/4W
R2148	1-215-419-00	METAL	820 1% 1/4W
R2149	1-215-414-00	METAL	510 1% 1/4W
R2150	1-215-409-00	METAL	330 1% 1/4W
R2151	1-215-407-00	METAL	270 1% 1/4W
R2152	1-215-404-00	METAL	200 1% 1/4W
R2153	1-215-401-11	METAL	150 1% 1/4W
R2154	1-215-399-00	METAL	120 1% 1/4W
R2155	1-215-397-00	METAL	100 1% 1/4W
R2156	1-215-421-00	METAL	1K 1% 1/4W
R2157	1-215-416-00	METAL	620 1% 1/4W
R2158	1-215-410-00	METAL	360 1% 1/4W
R2159	1-215-405-00	METAL	220 1% 1/4W
R2160	1-215-421-00	METAL	1K 1% 1/4W
<VARIABLE RESISTOR>			
RV2101	1-225-385-11	RES, VAR, CARBON 20K	

The components identified by shading and mark Δ are critical for safety. Replace only with part number specified.

Les composants identifiés par une trame et une marque Δ sont critiques pour la sécurité. Ne les remplacer que par une pièce portant le numéro spécifié.

H J X S Q

REF. NO.	PART NO.	DESCRIPTION	REMARK
RV2103	1-225-385-11	RES, VAR, CARBON 20K	
RV2105	1-225-385-11	RES, VAR, CARBON 20K	
RV2109	1-225-385-11	RES, VAR, CARBON 20K	
RV2113	1-225-385-11	RES, VAR, CARBON 20K	
RV2117	1-225-385-11	RES, VAR, CARBON 20K	
<SWITCH>			
S2101	1-572-811-21	SWITCH, TACTIL	
S2102	1-572-811-21	SWITCH, TACTIL	
S2103	1-572-811-21	SWITCH, TACTIL	
S2104	1-572-811-21	SWITCH, TACTIL	
S2105	1-572-811-21	SWITCH, TACTIL	
S2106	1-771-328-11	SWITCH, TACTILE	
S2107	1-771-328-11	SWITCH, TACTILE	
S2108	1-572-811-21	SWITCH, TACTIL	
S2109	1-572-811-21	SWITCH, TACTIL	
S2110	1-572-811-21	SWITCH, TACTIL	
S2111	1-572-811-21	SWITCH, TACTIL	
S2113	1-771-328-11	SWITCH, TACTILE	
S2114	1-771-328-11	SWITCH, TACTILE	

* A-1388-204-A J BOARD, COMPLETE *****			
<CONNECTOR>			
CN608	* 1-695-561-11	PIN, CONNECTOR (PC BOARD) 7P	
<SWITCH>			
S601	Δ 1-692-921-11	SWITCH, PUSH (A.C. POWER)	

* A-1390-778-A X BOARD, COMPLETE *****			
<CONNECTOR>			
CN108	* 1-564-518-11	PLUG, CONNECTOR 3P	
<DIODE>			
D001	8-719-301-36	DIODE SEL4410E-D	
D002	8-719-301-36	DIODE SEL4410E-D	
D003	8-719-301-36	DIODE SEL4410E-D	
D004	8-719-301-36	DIODE SEL4410E-D	

* A-1390-779-A S BOARD, COMPLETE (U/C model ONLY) *****			
<CAPACITOR>			
C805	1-102-978-00	CERAMIC 220PF 5% 50V	
C806	1-136-165-00	FILM 0.1MF 5% 50V	
C807	1-130-477-00	MYLAR 0.0033MF 5% 50V	
C810	1-136-165-00	FILM 0.1MF 5% 50V	
C811	1-136-165-00	FILM 0.1MF 5% 50V	
C812	1-136-495-11	FILM 0.068MF 5% 50V	
C813	1-124-261-00	ELECT 10MF 20% 50V	
C818	1-136-165-00	FILM 0.1MF 5% 50V	

REF. NO.	PART NO.	DESCRIPTION	REMARK
<CONNECTOR>			
CN801	* 1-573-896-11	SOCKET, CONNECTOR 12P	
<IC>			
<COIL>			
L801	1-410-470-11	INDUCTOR 10UH	
<RESISTOR>			
R802	1-249-435-11	CARBON 33K 5% 1/4W	
R803	1-247-863-91	CARBON 22K 5% 1/4W	
R804	1-215-454-00	METAL 24K 1% 1/4W	
R805	1-215-461-00	METAL 47K 1% 1/4W	
R808	1-249-417-11	CARBON 1K 5% 1/4W	
R812	1-249-417-11	CARBON 1K 5% 1/4W	
R813	1-249-417-11	CARBON 1K 5% 1/4W	
R815	1-247-843-11	CARBON 3.3K 5% 1/4W	
R816	1-249-418-11	CARBON 1.2K 5% 1/4W	
R817	1-249-418-11	CARBON 1.2K 5% 1/4W	
R818	1-249-418-11	CARBON 1.2K 5% 1/4W	
R819	1-249-418-11	CARBON 1.2K 5% 1/4W	
R820	1-249-422-11	CARBON 2.7K 5% 1/4W	

1-537-877-21 TERMINAL BOARD ASSY, I/O (Q BOARD) *****			
2-990-241-02 HOLDER (A), PLUG			
* 3-175-740-01 TERMINAL			
* 3-175-741-01 NUT			
* 3-175-742-01 WASHER			
3-178-213-21 SCREW +P 3X10			
7-685-135-19 SCREW +P 2.6X10 TYPE2 SLIT			
<CAPACITOR>			
C2401	1-163-111-00	CERAMIC CHIP 56PF 5% 50V	
C2402	1-104-396-11	ELECT 10MF 20% 16V	
C2403	1-104-396-11	ELECT 10MF 20% 16V	
C2404	1-104-396-11	ELECT 10MF 20% 16V	
C2405	1-124-589-11	ELECT 47MF 20% 16V	
C2406	1-104-396-11	ELECT 10MF 20% 16V	
C2407	1-104-396-11	ELECT 10MF 20% 16V	
C2408	1-104-396-11	ELECT 10MF 20% 16V	
C2409	1-124-234-00	ELECT 22MF 20% 16V	
C2410	1-163-033-91	CERAMIC CHIP 0.022MF 50V	
C2411	1-104-396-11	ELECT 10MF 20% 16V	
C2412	1-104-396-11	ELECT 10MF 20% 16V	
C2413	1-163-117-00	CERAMIC CHIP 100PF 5% 50V	
C2414	1-126-301-11	ELECT 1MF 20% 50V	
C2415	1-165-319-11	CERAMIC CHIP 0.1MF 50V	
C2416	1-124-589-11	ELECT 47MF 20% 16V	
C2418	1-163-033-91	CERAMIC CHIP 0.022MF 50V	
C2422	1-124-234-00	ELECT 22MF 20% 16V	
C2423	1-124-234-00	ELECT 22MF 20% 16V	
C2424	1-163-033-91	CERAMIC CHIP 0.022MF 50V	
C2425	1-124-589-11	ELECT 47MF 20% 16V	
C2426	1-124-589-11	ELECT 47MF 20% 16V	
C2427	1-124-234-00	ELECT 22MF 20% 16V	
C2428	1-163-033-91	CERAMIC CHIP 0.022MF 50V	
C2429	1-124-234-00	ELECT 22MF 20% 16V	
C2430	1-163-033-91	CERAMIC CHIP 0.022MF 50V	
C2431	1-124-234-00	ELECT 22MF 20% 16V	
C2432	1-124-234-00	ELECT 22MF 20% 16V	



Les composants identifiés par une trame et une marque Δ sont critiques pour la sécurité. Ne les remplacer que par une pièce portant le numéro spécifique.

The components identified by shading and mark Δ are critical for safety. Replace only with part number specified.

REF. NO.	PART NO.	DESCRIPTION	REMARK
C2433	1-163-033-91	CERAMIC CHIP 0.022MF	50V
C2434	1-124-463-00	ELECT 0.1MF	20% 50V
C2435	1-163-033-91	CERAMIC CHIP 0.022MF	50V
C2436	1-124-234-00	ELECT 22MF	20% 16V
C2437	1-163-033-91	CERAMIC CHIP 0.022MF	50V
C2438	1-124-234-00	ELECT 22MF	20% 16V
C2439	1-124-234-00	ELECT 22MF	20% 16V
C2440	1-163-033-91	CERAMIC CHIP 0.022MF	50V
C2441	1-124-234-00	ELECT 22MF	20% 16V
C2442	1-124-234-00	ELECT 22MF	20% 16V
C2443	1-124-234-00	ELECT 22MF	20% 16V
C2444	1-124-234-00	ELECT 22MF	20% 16V
C2445	1-163-033-91	CERAMIC CHIP 0.022MF	50V
C2446	1-163-033-91	CERAMIC CHIP 0.022MF	50V
C2447	1-124-234-00	ELECT 22MF	20% 16V
C2448	1-124-234-00	ELECT 22MF	20% 16V
C2449	1-124-234-00	ELECT 22MF	20% 16V
C2450	1-124-234-00	ELECT 22MF	20% 16V
C2451	1-124-589-11	ELECT 47MF	20% 16V
C2452	1-124-589-11	ELECT 47MF	20% 16V
C2454	1-126-163-11	ELECT 4.7MF	20% 25V
C2461	1-165-319-11	CERAMIC CHIP 0.1MF	50V
C2462	1-165-319-11	CERAMIC CHIP 0.1MF	50V
C2463	1-165-319-11	CERAMIC CHIP 0.1MF	50V
C2464	1-165-319-11	CERAMIC CHIP 0.1MF	50V
C2465	1-165-319-11	CERAMIC CHIP 0.1MF	50V
C2466	1-165-319-11	CERAMIC CHIP 0.1MF	50V
C2467	1-165-319-11	CERAMIC CHIP 0.1MF	50V
C2468	1-165-319-11	CERAMIC CHIP 0.1MF	50V
C2469	1-165-319-11	CERAMIC CHIP 0.1MF	50V
C2470	1-165-319-11	CERAMIC CHIP 0.1MF	50V
<CONNECTOR>			
CN306	1-564-526-11	PLUG, CONNECTOR 11P	
CN307	1-564-522-11	PLUG, CONNECTOR 7P	
CN308	1-564-519-11	PLUG, CONNECTOR 4P	
CN309	1-695-581-11	CONNECTOR, D SUB	
CN310	1-580-525-12	JACK, DC (POLARITY UNIFIED TYPE)	
CN2401	1-251-263-11	INLET, AC	
CN2402	1-565-167-12	TERMINAL, (S) (WITH SW) 4P	
CN2403	1-569-578-11	TERMINAL, S (WITH SW)	
<DIODE>			
D2402	8-719-016-74	DIODE 1SS352	
D2404	8-719-800-76	DIODE 1SS226	
D2405	8-719-800-76	DIODE 1SS226	
D2406	8-719-800-76	DIODE 1SS226	
D2407	8-719-800-76	DIODE 1SS226	
D2408	8-719-800-76	DIODE 1SS226	
D2409	8-719-800-76	DIODE 1SS226	
D2410	8-719-800-76	DIODE 1SS226	
D2411	8-719-800-76	DIODE 1SS226	
D2415	8-719-800-76	DIODE 1SS226	
D2416	8-719-800-76	DIODE 1SS226	
D2417	8-719-800-76	DIODE 1SS226	
D2418	8-719-800-76	DIODE 1SS226	
D2420	8-719-037-53	DIODE RD27SB-T1	
D2421	8-719-037-53	DIODE RD27SB-T1	
D2422	8-719-037-53	DIODE RD27SB-T1	
D2423	8-719-037-53	DIODE RD27SB-T1	
<IC>			
IC2401	8-759-509-71	IC XRU4021BF-E2	
IC2402	8-759-509-71	IC XRU4021BF-E2	
IC2403	8-759-287-89	IC MM1113XFF	
IC2404	8-759-084-76	IC MM1111XF	

REF. NO.	PART NO.	DESCRIPTION	REMARK
IC2405	8-759-287-89	IC MM1113XFF	
<JACK>			
J2401	1-562-261-71	CONNECTOR, COAXIAL (BNC)	
J2402	1-766-738-11	BNC (WITH SW)	
J2403	1-562-261-71	CONNECTOR, COAXIAL (BNC)	
J2404	1-766-738-11	BNC (WITH SW)	
J2405	1-562-261-71	CONNECTOR, COAXIAL (BNC)	
J2406	1-766-738-11	BNC (WITH SW)	
J2407	1-562-261-71	CONNECTOR, COAXIAL (BNC)	
J2408	1-766-738-11	BNC (WITH SW)	
J2409	1-562-261-71	CONNECTOR, COAXIAL (BNC)	
J2410	1-766-738-11	BNC (WITH SW)	
J2411	1-562-261-71	CONNECTOR, COAXIAL (BNC)	
J2412	1-766-738-11	BNC (WITH SW)	
J2413	1-507-802-41	JACK, PIN (MOUNT TYPE)	
J2414	1-507-802-41	JACK, PIN (MOUNT TYPE)	
J2415	1-507-802-41	JACK, PIN (MOUNT TYPE)	
J2416	1-507-802-41	JACK, PIN (MOUNT TYPE)	
J2417	1-507-802-41	JACK, PIN (MOUNT TYPE)	
J2418	1-507-802-41	JACK, PIN (MOUNT TYPE)	
J2419	1-507-802-41	JACK, PIN (MOUNT TYPE)	
J2420	1-750-628-11	DIN SOCKET 8P	
<CHIP CONDUCTOR>			
JR1	1-216-295-91	CONDUCTOR, CHIP	
JR4	1-216-295-91	CONDUCTOR, CHIP	
JR5	1-216-295-91	CONDUCTOR, CHIP	
JR7	1-216-295-91	CONDUCTOR, CHIP	
JR12	1-216-295-91	CONDUCTOR, CHIP	
JR13	1-216-295-91	CONDUCTOR, CHIP	
JR14	1-216-295-91	CONDUCTOR, CHIP	
JR15	1-216-295-91	CONDUCTOR, CHIP	
JR16	1-216-295-91	CONDUCTOR, CHIP	
JR17	1-216-295-91	CONDUCTOR, CHIP	
JR19	1-216-295-91	CONDUCTOR, CHIP	
JR20	1-216-295-91	CONDUCTOR, CHIP	
JR21	1-216-295-91	CONDUCTOR, CHIP	
JR23	1-216-295-91	CONDUCTOR, CHIP	
JR30	1-216-295-91	CONDUCTOR, CHIP	
JR34	1-216-295-91	CONDUCTOR, CHIP	
JR35	1-216-295-91	CONDUCTOR, CHIP	
JR40	1-216-295-91	CONDUCTOR, CHIP	
JR41	1-216-295-91	CONDUCTOR, CHIP	
JR43	1-216-295-91	CONDUCTOR, CHIP	
JR46	1-216-295-91	CONDUCTOR, CHIP	
JR47	1-216-295-91	CONDUCTOR, CHIP	
JR48	1-216-295-91	CONDUCTOR, CHIP	
JR52	1-216-295-91	CONDUCTOR, CHIP	
JR60	1-216-295-91	CONDUCTOR, CHIP	
<TRANSISTOR>			
Q2401	8-729-120-28	TRANSISTOR 2SC1623-L5L6	
Q2402	8-729-216-22	TRANSISTOR 2SA1162-G	
Q2403	8-729-216-22	TRANSISTOR 2SA1162-G	
Q2404	8-729-216-22	TRANSISTOR 2SA1162-G	
Q2405	8-729-216-22	TRANSISTOR 2SA1162-G	
Q2408	8-729-120-28	TRANSISTOR 2SC1623-L5L6	
Q2409	8-729-120-28	TRANSISTOR 2SC1623-L5L6	
Q2410	8-729-120-28	TRANSISTOR 2SC1623-L5L6	
Q2411	8-729-120-28	TRANSISTOR 2SC1623-L5L6	
Q2412	8-729-120-28	TRANSISTOR 2SC1623-L5L6	
Q2414	8-729-120-28	TRANSISTOR 2SC1623-L5L6	
Q2415	8-729-120-28	TRANSISTOR 2SC1623-L5L6	
Q2416	8-729-216-22	TRANSISTOR 2SA1162-G	
Q2417	8-729-120-28	TRANSISTOR 2SC1623-L5L6	



REF. NO.	PART NO.	DESCRIPTION	REMARK
		<RESISTOR>	
R2401	1-216-073-00	METAL GLAZE 10K	5% 1/10W
R2402	1-216-043-91	METAL GLAZE 560	5% 1/10W
R2404	1-216-089-91	METAL GLAZE 47K	5% 1/10W
R2405	1-216-073-00	METAL GLAZE 10K	5% 1/10W
R2406	1-216-089-91	METAL GLAZE 47K	5% 1/10W
R2407	1-216-073-00	METAL GLAZE 10K	5% 1/10W
R2408	1-216-089-91	METAL GLAZE 47K	5% 1/10W
R2409	1-216-073-00	METAL GLAZE 10K	5% 1/10W
R2410	1-216-089-91	METAL GLAZE 47K	5% 1/10W
R2411	1-216-073-00	METAL GLAZE 10K	5% 1/10W
R2412	1-216-089-91	METAL GLAZE 47K	5% 1/10W
R2413	1-216-073-00	METAL GLAZE 10K	5% 1/10W
R2414	1-216-089-91	METAL GLAZE 47K	5% 1/10W
R2415	1-216-089-91	METAL GLAZE 47K	5% 1/10W
R2416	1-216-089-91	METAL GLAZE 47K	5% 1/10W
R2417	1-216-073-00	METAL GLAZE 10K	5% 1/10W
R2418	1-216-089-91	METAL GLAZE 47K	5% 1/10W
R2419	1-216-073-00	METAL GLAZE 10K	5% 1/10W
R2420	1-216-089-91	METAL GLAZE 47K	5% 1/10W
R2421	1-216-073-00	METAL GLAZE 10K	5% 1/10W
R2422	1-216-089-91	METAL GLAZE 47K	5% 1/10W
R2423	1-216-073-00	METAL GLAZE 10K	5% 1/10W
R2424	1-216-089-91	METAL GLAZE 47K	5% 1/10W
R2425	1-216-073-00	METAL GLAZE 10K	5% 1/10W
R2426	1-214-775-00	METAL 82K	1% 1/4W
R2427	1-216-097-91	METAL GLAZE 100K	5% 1/10W
R2428	1-216-105-91	METAL GLAZE 220K	5% 1/10W
R2429	1-216-025-91	METAL GLAZE 100	5% 1/10W
R2430	1-216-115-00	METAL GLAZE 560K	5% 1/10W
R2431	1-216-077-00	METAL GLAZE 15K	5% 1/10W
R2432	1-214-775-00	METAL 82K	1% 1/4W
R2433	1-216-097-91	METAL GLAZE 100K	5% 1/10W
R2434	1-216-105-91	METAL GLAZE 220K	5% 1/10W
R2435	1-216-025-91	METAL GLAZE 100	5% 1/10W
R2436	1-216-115-00	METAL GLAZE 560K	5% 1/10W
R2437	1-216-295-91	CONDUCTOR, CHIP	
R2438	1-216-077-00	METAL GLAZE 15K	5% 1/10W
R2439	1-214-775-00	METAL 82K	1% 1/4W
R2440	1-216-105-91	METAL GLAZE 220K	5% 1/10W
R2441	1-216-097-91	METAL GLAZE 100K	5% 1/10W
R2442	1-216-025-91	METAL GLAZE 100	5% 1/10W
R2443	1-216-115-00	METAL GLAZE 560K	5% 1/10W
R2444	1-216-077-00	METAL GLAZE 15K	5% 1/10W
R2446	1-214-775-00	METAL 82K	1% 1/4W
R2447	1-216-105-91	METAL GLAZE 220K	5% 1/10W
R2448	1-216-097-91	METAL GLAZE 100K	5% 1/10W
R2449	1-216-025-91	METAL GLAZE 100	5% 1/10W
R2450	1-216-115-00	METAL GLAZE 560K	5% 1/10W
R2451	1-216-077-00	METAL GLAZE 15K	5% 1/10W
R2452	1-216-089-91	METAL GLAZE 47K	5% 1/10W
R2453	1-216-073-00	METAL GLAZE 10K	5% 1/10W
R2455	2-216-113-00	METAL GLAZE 470K	5% 1/10W
R2458	1-216-295-91	CONDUCTOR, CHIP	
R2463	1-216-085-00	METAL GLAZE 33K	5% 1/10W
R2465	1-216-073-00	METAL GLAZE 10K	5% 1/10W
R2466	1-216-073-00	METAL GLAZE 10K	5% 1/10W
R2467	1-216-073-00	METAL GLAZE 10K	5% 1/10W
R2470	1-214-702-00	METAL 75	1% 1/4W
R2471	1-216-093-00	METAL GLAZE 68K	5% 1/10W
R2472	1-216-063-91	METAL GLAZE 3.9K	5% 1/10W
R2473	1-216-037-00	METAL GLAZE 330	5% 1/10W
R2474	1-216-049-91	METAL GLAZE 1K	5% 1/10W
R2475	1-216-091-00	METAL GLAZE 56K	5% 1/10W
R2476	1-214-702-00	METAL 75	10% 1/4W
R2477	1-216-091-00	METAL GLAZE 56K	5% 1/10W
R2478	1-216-063-91	METAL GLAZE 3.9K	5% 1/10W
R2479	1-216-027-00	METAL GLAZE 120	5% 1/10W

REF. NO.	PART NO.	DESCRIPTION	REMARK
R2480	1-216-049-91	METAL GLAZE 1K	5% 1/10W
R2481	1-216-093-00	METAL GLAZE 68K	5% 1/10W
R2482	1-214-702-00	METAL 75	1% 1/4W
R2483	1-216-091-00	METAL GLAZE 56K	5% 1/10W
R2484	1-216-027-00	METAL GLAZE 120	5% 1/10W
R2485	1-216-063-91	METAL GLAZE 3.9K	5% 1/10W
R2486	1-216-049-91	METAL GLAZE 1K	5% 1/10W
R2487	1-216-093-00	METAL GLAZE 68K	5% 1/10W
R2488	1-214-702-00	METAL 75	1% 1/4W
R2489	1-216-091-00	METAL GLAZE 56K	5% 1/10W
R2490	1-216-063-91	METAL GLAZE 3.9K	5% 1/10W
R2491	1-216-027-00	METAL GLAZE 120	5% 1/10W
R2492	1-216-049-91	METAL GLAZE 1K	5% 1/10W
R2493	1-216-093-00	METAL GLAZE 68K	5% 1/10W
R2494	1-214-702-00	METAL 75	1% 1/4W
R2495	1-214-702-00	METAL 75	1% 1/4W
R2496	1-216-091-00	METAL GLAZE 56K	5% 1/10W
R2497	1-216-063-91	METAL GLAZE 3.9K	5% 1/10W
R2498	1-216-037-00	METAL GLAZE 330	5% 1/10W
R2499	1-216-049-91	METAL GLAZE 1K	5% 1/10W
R3400	1-216-093-00	METAL GLAZE 68K	5% 1/10W
R3402	1-216-091-00	METAL GLAZE 56K	5% 1/10W
R3404	1-216-063-91	METAL GLAZE 3.9K	5% 1/10W
R3405	1-216-037-00	METAL GLAZE 330	5% 1/10W
R3406	1-216-049-91	METAL GLAZE 1K	5% 1/10W
R3408	1-216-093-00	METAL GLAZE 68K	5% 1/10W
R3409	1-214-702-00	METAL 75	1% 1/4W
R3410	1-216-091-00	METAL GLAZE 56K	5% 1/10W
R3411	1-216-063-91	METAL GLAZE 3.9K	5% 1/10W
R3412	1-216-037-00	METAL GLAZE 330	5% 1/10W
R3413	1-216-073-00	METAL GLAZE 10K	5% 1/10W
R3414	1-216-073-00	METAL GLAZE 10K	5% 1/10W
R3416	1-216-049-91	METAL GLAZE 1K	5% 1/10W
R3417	1-216-093-00	METAL GLAZE 68K	5% 1/10W
R3418	1-214-702-00	METAL 75	1% 1/4W
R3419	1-216-037-00	METAL GLAZE 330	5% 1/10W
R3420	1-216-023-00	METAL GLAZE 82	5% 1/10W
R3421	1-216-689-11	METAL GLAZE 39K	5% 1/10W
R3422	1-216-049-91	METAL GLAZE 1K	5% 1/10W
R3423	1-216-083-00	METAL GLAZE 27K	5% 1/10W
R3424	1-216-049-91	METAL GLAZE 1K	5% 1/10W
R3425	1-216-061-00	METAL GLAZE 3.3K	5% 1/10W
R3426	1-216-099-00	METAL GLAZE 120	5% 1/10W
R3427	1-216-089-91	METAL GLAZE 47K	5% 1/10W
R3428	1-216-073-00	METAL GLAZE 10K	5% 1/10W
R3429	1-216-089-91	METAL GLAZE 47K	5% 1/10W
R3430	1-216-073-00	METAL GLAZE 10K	5% 1/10W
R3431	1-216-089-91	METAL GLAZE 47K	5% 1/10W
R3432	1-216-073-00	METAL GLAZE 10K	5% 1/10W
R3435	1-216-045-91	METAL GLAZE 680	5% 1/10W
R3436	1-216-045-91	METAL GLAZE 680	5% 1/10W
R3437	1-216-045-91	METAL GLAZE 680	5% 1/10W
R3438	1-216-045-91	METAL GLAZE 680	5% 1/10W
R3439	1-216-045-91	METAL GLAZE 680	5% 1/10W

<SWITCH>

S2401	1-570-598-11	SWITCH, DIP	
-------	--------------	-------------	--

Les composants identifiés par une trame et une marque Δ sont critiques pour la sécurité. Ne les remplacer que par une pièce portant le numéro spécifique.

The components identified by shading and mark Δ are critical for safety. Replace only with part number specified.

REF. NO.	PART NO.	DESCRIPTION	REMARK
MISCELLANEOUS *****			
	Δ 1-238-368-11	RESISTOR ASSY, HIGH-VOLTAGE (20inch)	
	Δ 1-426-442-21	COIL, DEMAGNETIZATION (14inch)	
	Δ 1-426-505-11	COIL, DEMAGNETIZATION (20inch)	
	Δ 1-451-349-12	DEFLECTION YOKE (Y20FZA) (20inch)	
	1-452-032-00	MAGNET, DISK 10mm ϕ	
	1-452-094-00	MAGNET, ROTATABLE DISK ; 15mm ϕ	
	Δ 1-532-742-11	FUSE, GLASS TUBE 1.6A/125V	
	1-537-877-21	TERMINAL BOARD ASSY, I/O (Q BOARD)	
	1-543-653-11	CORE ASSY, BEAD(DIVISION TYPE)	
	1-543-827-11	CLAMP, SLEEVE FERRITE	
	1-544-063-12	SPEAKER	
	Δ 1-576-231-11	FUSE (H.B.C.) 4A/250V	
	Δ 8-451-472-11	DEFLECTION YOKE Y14MGAT (14inch)	
V901	Δ 8-736-135-05	PICTURE TUBE 20FZ5(DARK) (M49JGH11X) (20inch)	
V901	Δ 8-738-342-05	PICTURE TUBE 14MG(DARK) (M34KBE11X) (14inch)	

REF. NO.	PART NO.	DESCRIPTION	REMARK
ACCESSORIES AND PACKING MATERIALS *****			
	Δ 1-559-945-11	CORD, POWER (10A/125V) (U/C model)	
	1-690-871-11	CABLE (MINI DIN) 8P	
	Δ 1-690-871-11	CORD SET, POWER (AUS model)	
	Δ 1-765-719-11	CORD SET, POWER (AEP model)	
	3-170-078-01	HOLDER (B), PLUG	
	3-861-644-03	INSTRUCTIONS FOR USE	
	3-861-699-11	MANUAL, INTERFACE	
	* 4-043-769-01	CUSHION (UPPER) (ASSY) (20inch)	
	* 4-043-770-01	CUSHION (LOWER) (ASSY) (20inch)	
	4-048-070-01	HINGE, COVER	
	4-048-071-01	COVER, CONTROL PANEL (14inch)	
	4-048-072-01	COVER, CONTROL PANEL (20inch)	
	4-048-073-01	COVER, DROP PROTECTION	
	* 4-058-819-01	INDIVIDUAL CARTON (20inch)	
	* 4-058-820-01	INDIVIDUAL CARTON (14inch)	
	* 4-058-821-01	CUSHION (UPPER) (ASSY) (14inch)	
	* 4-058-822-01	CUSHION (LOWER) (ASSY) (14inch)	
	* 4-380-432-21	BAG, PROTECTION (20inch)	
	* 4-381-155-11	BAG, PROTECTION (14inch)	

SERVICE MANUAL

MODEL	DEST.	CHASSIS NO.	MODEL	DEST.	CHASSIS NO.
OEV143	US/CND	SCC-N59D-A	OEV203 ✓	US/CND	SCC-N59C-A
OEV143	AEP	SCC-N33H-A	OEV203	AEP	SCC-N33G-A
OEV143	E	SCC-N89A-A	OEV203	E	SCC-N89B-A



SP00730

DIFFERENCE-1 Revised1

Contents of service manual for OEV143/203 (OEM production of OLYMPUS OPTICAL CO.,LTD.) is indicating differences between original model only. PVM-14M2MDU/14M2MDE/14M2MDA/20M2MDU/20M2MDE/20M2MDA for repair.

Section 3 Set-Up Adjustments

3-3. Writing Model Data (Page 3-5)

1. Write model data on respective models in the service mode at the location of No.102 MODEL in accordance with Table 3-3.

Table 3-3

Model	Model data
PVM-20M2MDU	0
PVM-20M2MDE	2
PVM-20M2MDA	3
PVM-14M2MDU	4
PVM-14M2MDE	6
PVM-14M2MDA	7
OEV203 (US/CND)	29
OEV203 (AEP/E)	31
OEV143 (US/CND)	26
OEV143 (AEP/E)	28

2. Write the following data in the service mode at the location of No.103 COLOR TEMP DISP 1.
COLOR TEMP DISP 1

65

3. Write the following data in the service mode at the location of No.104 COLOR TEMP DISP 2.
COLOR TEMP DISP 2

56

4. Write the following data in the service mode at the location of No.105 COLOR TEMP DISP 3.
COLOR TEMP DISP 3

93

- * Standard inspection state
Unless otherwise specified in this manual, make adjustment under the following conditions:

APERTURE	MIN	(Turn FLAT fully counterclockwise.)
BRIGHT	50%	(Center click)
CHROMA	50%	(Center click)
PHASE	50%	(Center click)
CONTRAST	80%	(Center click)
VOLUME	50%	

TRINITRON® COLOR VIDEO MONITOR

SONY®

3-12. Focus Adjustment (Page 3-10)

1. 20 inch Models

OEV203 only

Press MENU and select SUB CONTROL.

Set as follows :

SUB CONTRAST : +40

SUB BRIGHT : +20 (US/Canadian models)

SUB BRIGHT : +10 (AEP/E models)

1. Input a 525 monoscope signal.
2. Adjust the focus to optimize the focus on the characters "30" at the center of the screen with FOCUS PACK VR.
3. Switch to an all-white signal and check the uniformity.
4. After focus adjustment, paint-lock the FOCUS PACK VR knob.

2. 14 inch Models

OEV143 only

Press MENU and select SUB CONTROL.

Set as follows :

SUB CONTRAST : +40

SUB BRIGHT : +20

1. Input a 525 dot signal.
2. Make adjustment so that the center dot and center of the dots on both sides are not separated with using RV707 on C board.
3. Check that the resolution is more than 600 lines by means of a digital monoscope signal.
4. Change an all-white signal, and check that the magenta ring is unobscured by means.

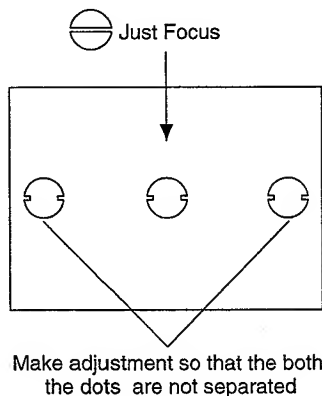

Fig. 3-28

Section 5 Circuit Adjustments

9. Adjustment of Sub Cont (Page 5-9)

OEV143/203 only

Press MENU and select SUB CONTROL.

Set as follows :

SUB CONTRAST : +40

SUB BRIGHT : +20

- 1) Input the window signal.
- 2) Enter the Normal mode.
- 3) Attach a luminance meter to the window of the CRT surface.
- 4) Make adjustment so that the values will be as shown in Table 5-7 with SUB CON <NORM>.
- 5) Enter the O/S mode.
- 6) Make adjustment so that the values will be as shown in Table 5-7 with SUB CON <O/S>.

Table 5-7

Unit (cd/m²)

	PVM-14	PVM-20	OEV143/203
SUB CON <NORM>	170±20	150±20	210±20
SUB CON <O/S>	170±20	150±20	210±20

Section 7
Exploded Views
7-2. Picture Tube (PVM-14M2MDU/E/A) (Page 7-2)

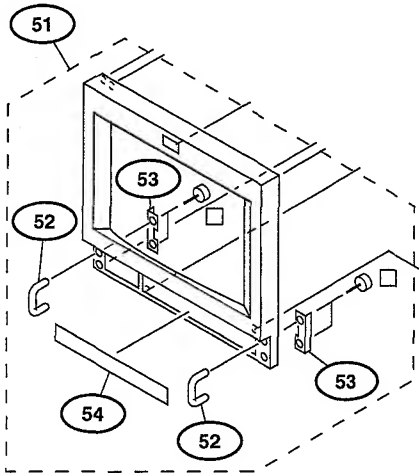
PVM-14M2MDU/E/A				OEV143				
								
Ref.No.	Part No.	Description	Remark		Ref.No.	Part No.	Description	Remark
51	X-4035-199-1	BEZEL ASSY	52-54		51	X-4035-691-1	BEZEL ASSY	52-54

7-4. Picture Tube (PVM-20M2MDU/E/A) (Page 7-4)

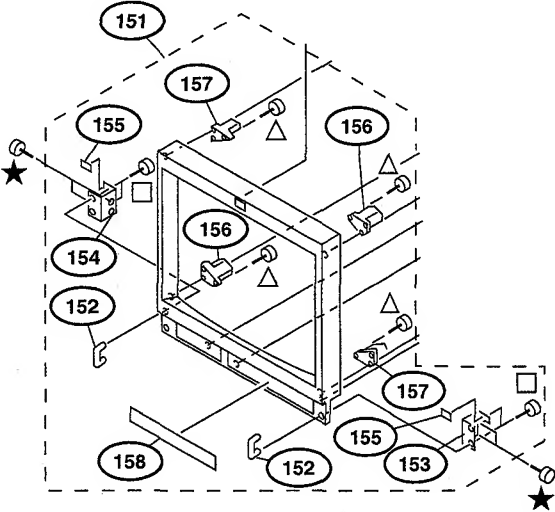
PVM-20M2MDU/E/A				OEV203				
								
Ref.No.	Part No.	Description	Remark		Ref.No.	Part No.	Description	Remark
151	X-4035-198-1	BEZEL ASSY	152-158		151	X-4035-689-1	BEZEL ASSY	152-158

Section 8
Electrical Parts List
Accessories and Packing Materials (Page 8-32)

PVM-14M2MDU/E/A/20M2MDU/E/A				OEV143/203			
Ref.No.	Part No.	Description	Remark	Ref.No.	Part No.	Description	Remark
	3-861-644-03	INSTRUCTIONS FOR USE (JAPANESE, ENGLISH, FRENCH, GERMAN, ITALIAN, SPANISH, CHINESE)		1-543-947-11		CORE, FERRITE	
				3-862-979-11		MANUAL, INSTRUCTION (US/CND) (ENGLISH, FRENCH, SPANISH)	
				3-862-979-21		MANUAL, INSTRUCTION (AEP) (ENGLISH, FRENCH, GERMAN, ITALIAN, SPANISH)	



P00730

SERVICE MANUAL

<u>MODEL</u>	<u>DEST.</u>	<u>CHASSIS NO.</u>	<u>MODEL</u>	<u>DEST.</u>	<u>CHASSIS NO.</u>
OEV-143	US/CND	SCC-N59D-A	OEV-203	US/CND	SCC-N59C-A
OEV-143	AEP	SCC-N33H-A	OEV-203	AEP	SCC-N33G-A

Contents of service manual for OEV-143/203 (OEM production of OLYMPUS OPTICAL CO.,LTD.) is indicating differences between original model only.
PVM-14M2MDU/14M2MDE/14M2MDA/20M2MDU/20M2MDE/20M2MDA for repair.

DIFFERENCE-1

SPO584 # 2039/06
03 mm

SECTION 7 EXPLODED VIEWS 7-2. PICTURE TUBE (14M2MDU/E/A) (PAGE 7-2)

PVM-14M2MDU/E/A				OEV-143			
REF NO.	PART NO.	DESCRIPTION	REMARK	REF NO.	PART NO.	DESCRIPTION	REMARK
51	X-4035-199-1	BEZEL ASSY	52-54	51	X-4035-691-1	BEZEL ASSY	52-54

TRINITRON® COLOR VIDEO MONITOR

SONY

7-4. PICTURE TUBE (20M2MDU/E/A) (PAGE 7-4)

PVM-20M2MDU/E/A				OEV-203			
REF NO.	PART NO.	DESCRIPTION	REMARK	REF NO.	PART NO.	DESCRIPTION	REMARK
151	X-4035-198-1	BEZEL ASSY	152-158	151	X-4035-689-1	BEZEL ASSY	152-158

SECTION 8
ELECTRICAL PARTS LIST
ACCESSORIES AND PACKING MATERIALS (PAGE 8-32)

PVM-14M2MDU/E/A/20M2MDU/E/A				OEV-143/203			
REF NO.	PART NO.	DESCRIPTION	REMARK	REF NO.	PART NO.	DESCRIPTION	REMARK
	3-861-644-03	INSTRUCTIONS FOR USE (JAPANESE, ENGLISH, FRENCH, GERMAN, ITALIAN, SPANISH, CHINESE)			1-543-947-11	CORE, FERRITE	
					3-862-979-11	MANUAL, INSTRUCTION (US/CND) (ENGLISH, FRENCH, SPANISH)	
					3-862-979-21	MANUAL, INSTRUCTION (AEP) (ENGLISH, FRENCH, GERMAN, ITALIAN, SPANISH)	