

8	7	6	5	4	3	2	1
PAGE		CONTENTS		PAGE		CONTENTS	
[1]	COVER PAGE]	[27]	CPU VREG OUTPUT FILTER]	<div style="text-align: center;"> <p>SCHMATIC REV 12.0</p> <p>PBA NUMBER A88754-300</p> <p>REV 01</p> <p>BOM RELEASE DATE 04/26/02</p> <p>DVT REV 12.0 FAB P</p> <p>STANDARD BOM: MICRON DDR SEE PAGE 13 FOR SAMSUNG ALT</p> <p>XBLADE</p> </div>			
[2]	BLOCK DIAGRAM]	[28]	1.5V SWITCHING REGULATOR]				
[3]	RESET MAP]	[29]	CLOCK GENERATOR]				
[4]	GPIO/IDSEL TABLE]	[30]	1.25V LINEAR REGULATOR]				
[5]	PENTIUM III BGA2 PART 1 OF 4]	[31]	LINEAR_REGULATORS_1.5_2.5]				
[6]	PENTIUM III BGA2 PART 2 OF 4]	[32]	DVT POWER CONNECTOR]				
[7]	PENTIUM III BGA2 PARTS 3 & 4]	[33]	BULK DECOUPLING]				
[8]	CPU VCORE DECOUPLING]	[34]	SUPERCAP VBAT REGULATOR]				
[9]	CPU VTT DECOUPLING]	[35]	LAN ICS1893]				
[10]	ITP TERMINATION]	[36]	LAN JACK/THERMAL SENSE/EEPROM]				
[11]	NV2A 1 OF 2(NORTH BRIDGE)]	[37]	IDE]				
[12]	NV2A 2 OF 2(NORTH BRIDGE)]	[38]	AUDIO CODEC]				
[13]	NV2A STRAPPING]	[39]	AUDIO AMPLIFIER]				
[14]	DDR SDRAM (PARTITION A)]	[40]	AUDIO VREG AND BIAS]				
[15]	DDR SDRAM (PARTITION B)]	[41]	CX25871\SAN ANTONIO VIDEO-ENCODER]				
[16]	DDR SDRAM (PARTITION C)]	[42]	CX25874 VIDEO DAC AND TV ENCODER]				
[17]	DDR SDRAM (PARTITION D)]	[43]	VIDEO DAC AND TV ENCODER]				
[18]	DDR PARALLEL TERM DATA A/B]	[44]	AV CONNECTOR]				
[19]	DDR PARALLEL TERM DATA C/D]	[45]	LABELS AND MOUNTING HOLES]				
[20]	VTERM DECOUPLING]	[46]	FLASH]				
[21]	MEMORY DECOUPLING]	[47]	USB FRONT PANEL]				
[22]	NV2A DECOUPLING]	[48]	NV2A FAN/5V DRAIN/BROWN OUT]				
[23]	MCPX 1 OF 2]	[49]	SMC/FAN/DVD PWR/FRONT PANEL]				
[24]	MCPX 2 OF 2]	[50]	MCPX MUXED PIN ASSIGNMENT]				
[25]	MCPX INPUT STRAPS]	[51-56]	INDEX]				
[26]	CPU VOLTAGE REGULATOR]						
<p>NOTES:</p> <ol style="list-style-type: none"> <li>THIS SCHEMATIC DOCUMENTS THE GENERIC PRODUCT WITH ALL POSSIBLE CONFIGURATIONS. PLEASE REFER TO SPECIFIC PRODUCT PBA EPLS FOR ITEMS SHOWN AS OPTIONAL IN THE SCHEMATIC.</li> <li>RESISTORS ARE IN OHMS UNLESS OTHERWISE SPECIFIED.</li> <li>VCC = +5V UNLESS OTHERWISE SPECIFIED.</li> <li>* SUFFIX INDICATES ACTIVE LOW SIGNAL.</li> <li>\I SUFFIX INDICATES SIGNAL EXITS HIERARCHICAL BLOCK.</li> <li>THIS DOCUMENT ALSO EXISTS ON ELECTRONIC MEDIA.</li> </ol> <p>[PAGE_TITLE=COVER PAGE]</p>							
<p>DRAWING: DUTFABP_SCH_1_1 Fri May 03 11:23:32 2002</p>							
BOM RELEASE DATE		xx/xx/xx	PB NUMBER		XXXXXX-XXX		
SIGNATURE		DATE	intel		3065 BOWERS AVE SANTA CLARA, CA 95051		
DRN BY			TITLE		SCH, PBA, XBLADE		
CHK BY		xxxxxx	XXXXXX				
EPLD			INTEL		DOCUMENT NUMBER	PAGE	REV
APUD			CONFIDENTIAL		XXXXXX	1/56	12.0
APUD							

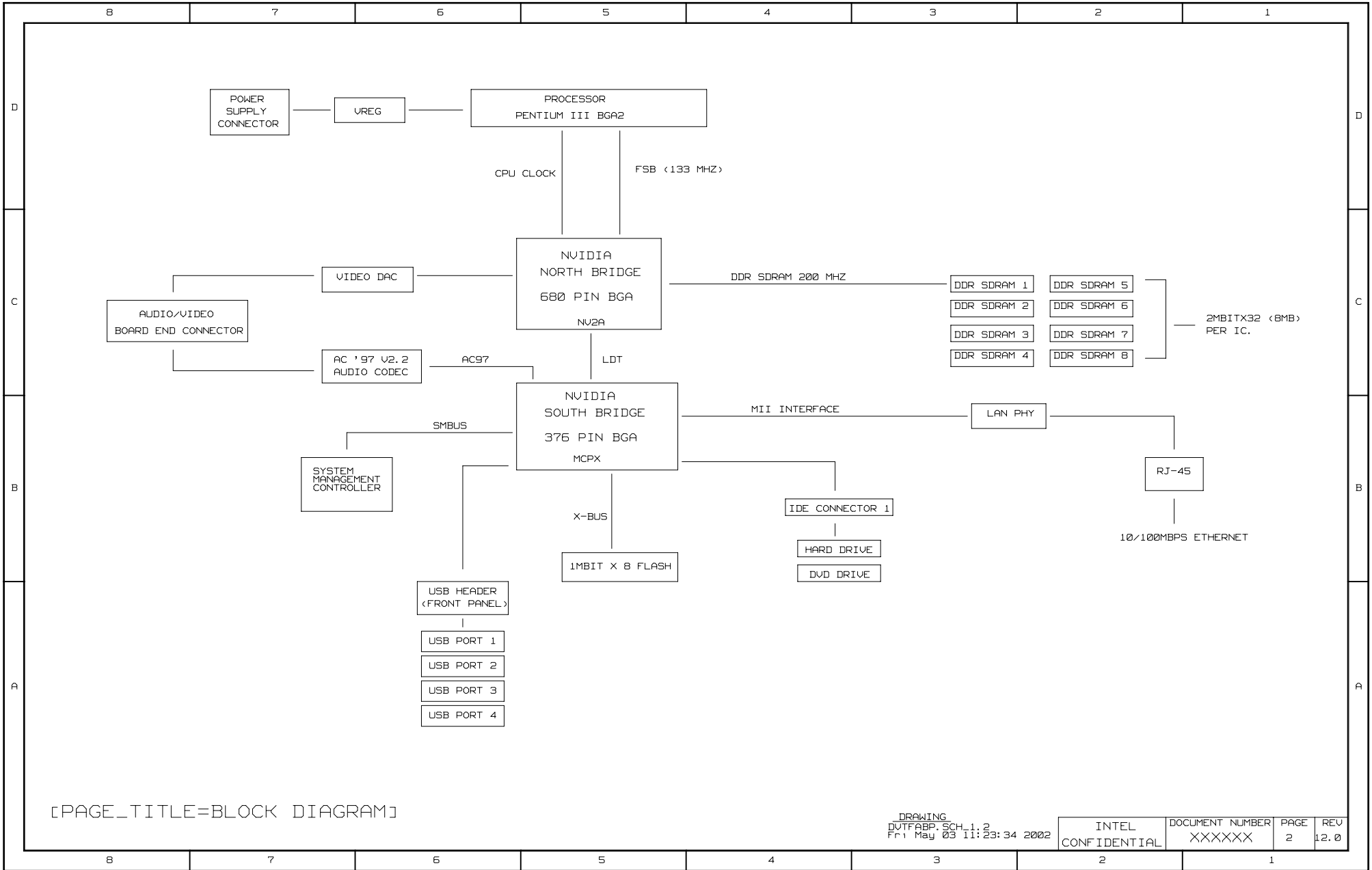

[PAGE\_TITLE=BLOCK DIAGRAM]

DRAWING  
 DUTFABP\_SCH\_1\_2  
 Fri May 03 11:23:34 2002

INTEL CONFIDENTIAL	DOCUMENT NUMBER XXXXXX	PAGE 2	REV 12.0
-----------------------	---------------------------	-----------	-------------

# RESET & POWER-ON MAP

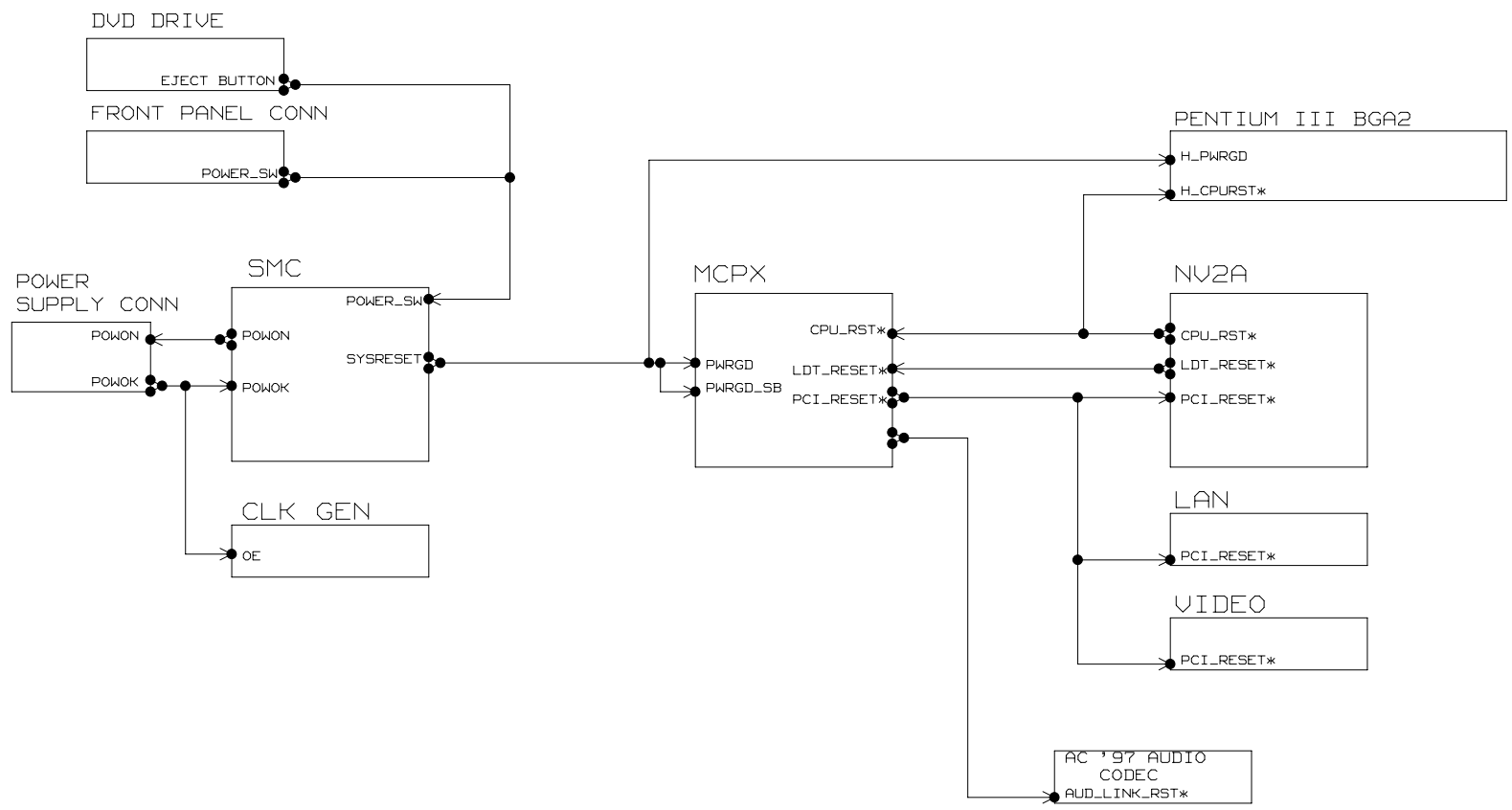

[PAGE\_TITLE=RESET MAP]

DRAWING  
 DUTFABP\_SCH\_1\_3  
 Fri May 03 11:23:35 2002

INTEL CONFIDENTIAL	DOCUMENT NUMBER XXXXXX	PAGE 3	REV 12.0
-----------------------	---------------------------	-----------	-------------

### PCI DEVICE MAP

DEVICE	PCI BUS #	DEVICE #	FUNCTION	DEVICE ID	COMMENTS
NV2A					
HOST BRIDGE	00	00	00	02A8	IT IS DIFFERENT FUNCTIONALLY FROM CRUSH12
AGP BRIDGE	00	30	00	01B7	SECONDARY BRIDGE #=1 IN STD ENUMERATION
NV2A	02	00	00	02A0	
MCPX					
APU	00	05	00	01B0	
AUDIO CODEC	00	06	00	01B1	
USB1.1 OHCI A	00	02	00	01C2	
USB1.1 OHCI B	00	03	00	01C2	
MAC	00	04	00	01C3	
IDE	00	09	00	01BC	
SMBUS2	00	01	01	01B4	
SUBTRACTIVE	00	01	00	01B2	INCLUDES LEGACY AND LPC (BIOS)

### GPIO USAGE TABLE

DEVICE	NAME	I/O	POWER WELL	DURING RESET	AFTER RESET	USAGE
MCPX	GPIO0	OUT	UCC3	Z	Z	TESTPOINT (NOT USED)
MCPX	GPIO1	OUT	UCC3	H	H	CNFG_SEL1
MCPX	GPIO14	IN	UCC3	Z	Z	CNFG_SEL0
MCPX	GPIO15	OUT	UCC3	Z	Z	TP_DEBUG_GPIO15
MCPX	GPIO16	IN	UCC3	Z	Z	CNFG_SEL2
MCPX	GPIO19	OUT	UCC3	Z	Z	LULCNT1
MCPX	GPIO20	OUT	UCC3	Z	Z	TESTPOINT (NOT USED)
MCPX	GPIO21	IN	UCC3	H	H	SMI* INPUT FROM SMC
MCPX	GPIO22	OUT	UCC3	Z	Z	LULCNT0
MCPX	GPIO24		UCC3	Z	Z	TESTPOINT (NOT USED)

### SMBUS ADDRESS MAP

DEVICE	SMBUS #	ADDRESS	EVT	DVT	COMMENTS
CX25B71	1	8A/8B		X	CONNECT ALTADDR (PIN 48) TO 3.3
CNR EEPROM	1	A8/A9	X	X	CONNECT CNR_SMB[2:0]=100 BINARY
MCP1 SMB1	1	10/11	X	X	SMBUS HOST (WRITE/READ)
SMC	1	20/21	X	X	(WRITE/READ)
TEMP(ADM1032)	1	98/99	X	X	(WRITE/READ)
DIMM0	0	A0/A1	X		M_LA_CS[1..0]*
DIMM1	0	A2/A3	X		M_LB_CS[1..0]*
DIMM2	0	A4/A5			M_LB_CS[3..2]*
MCP1 SMB0	0	10/11	X		SMBUS HOST (WRITE/READ)

\*NOTE: DEVICES ON SMBUS 0 DON'T EXIST ON DVT.

[PAGE\_TITLE=GPIO/IDSEL TABLE]

DRAWING  
DVT FAB. SCH 1.4  
Fri May 03 11:23:35 2002

INTEL CONFIDENTIAL	DOCUMENT NUMBER XXXXXX	PAGE 4	REV 12.0
-----------------------	---------------------------	-----------	-------------

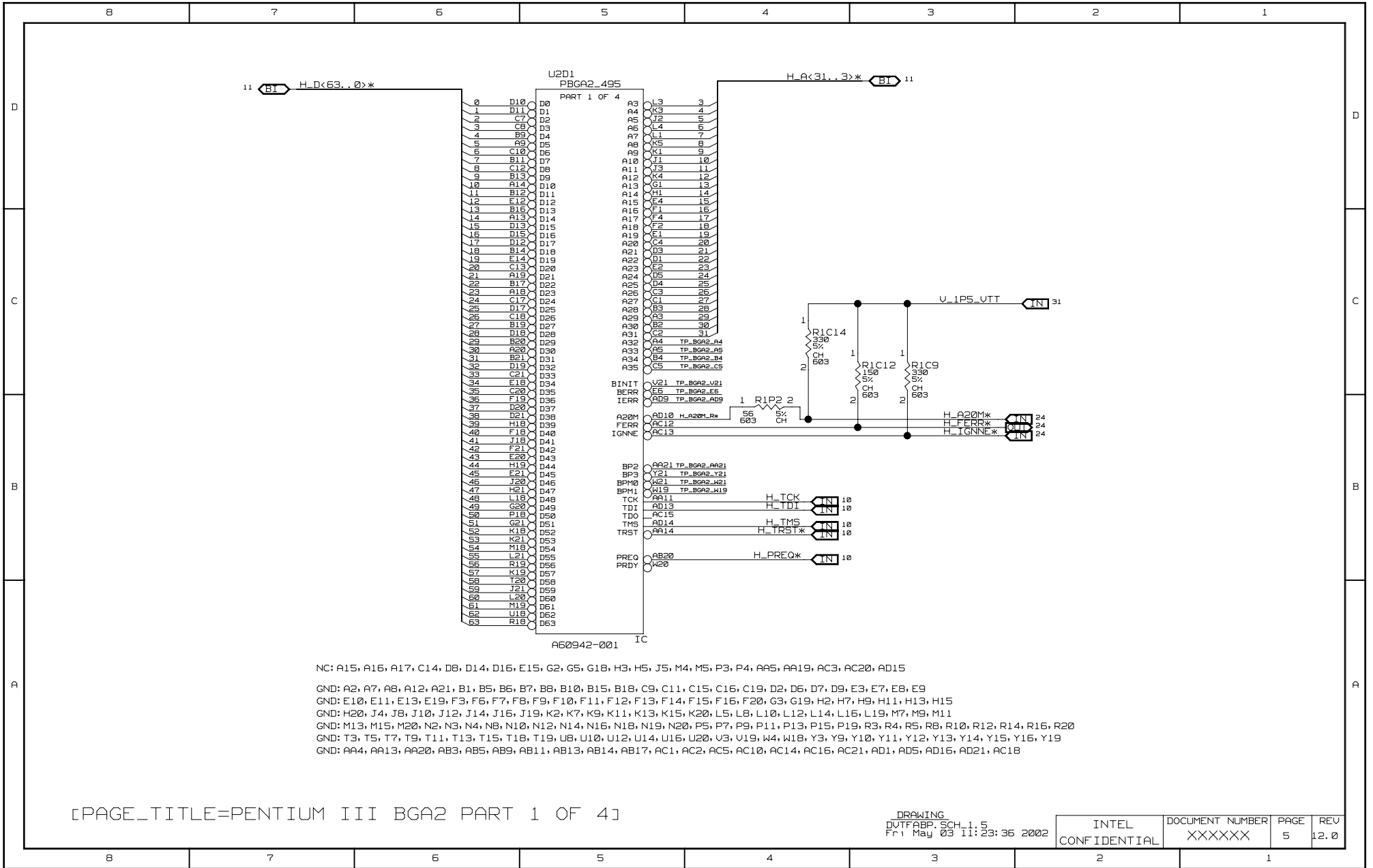

[PAGE\_TITLE=PENTIUM III BGA2 PART 1 OF 4]

DRAWING  
DVT/FABP\_SCH 11:5  
Fri May 03 11:23:36 2002

INTEL	DOCUMENT NUMBER	PAGE	REV
CONFIDENTIAL	XXXXXX	5	12.0

BSEL1	BSEL0	SYSTEM BUS FREQUENCY
0	0	RESERVED
0	1	100 MHZ
1	0	RESERVED
1	1	133 MHZ

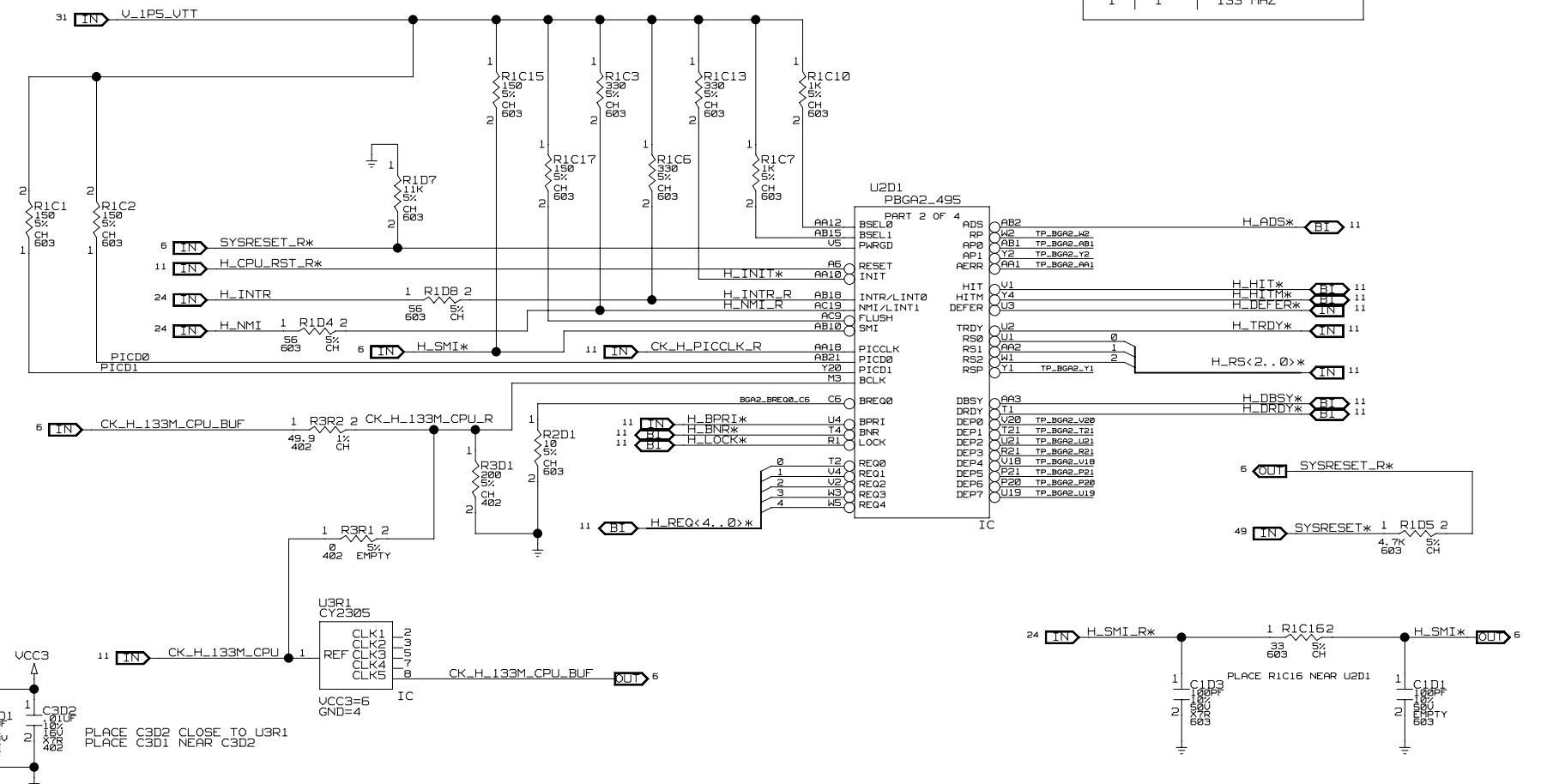

PLACE C3D2 CLOSE TO U3R1  
PLACE C3D1 NEAR C3D2

PLACE R1C16 NEAR U2D1

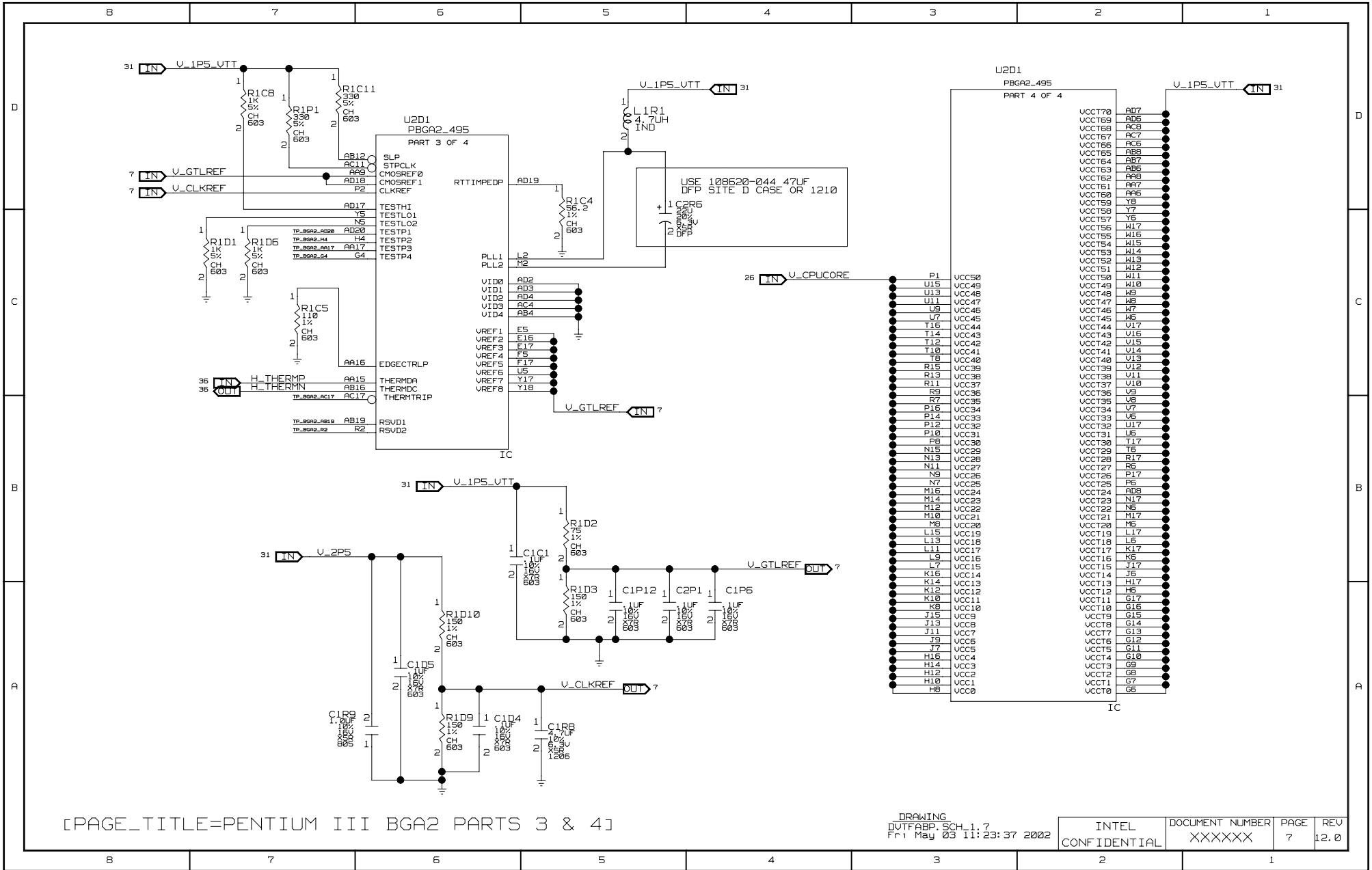

# CPU VCORE DECOUPLING

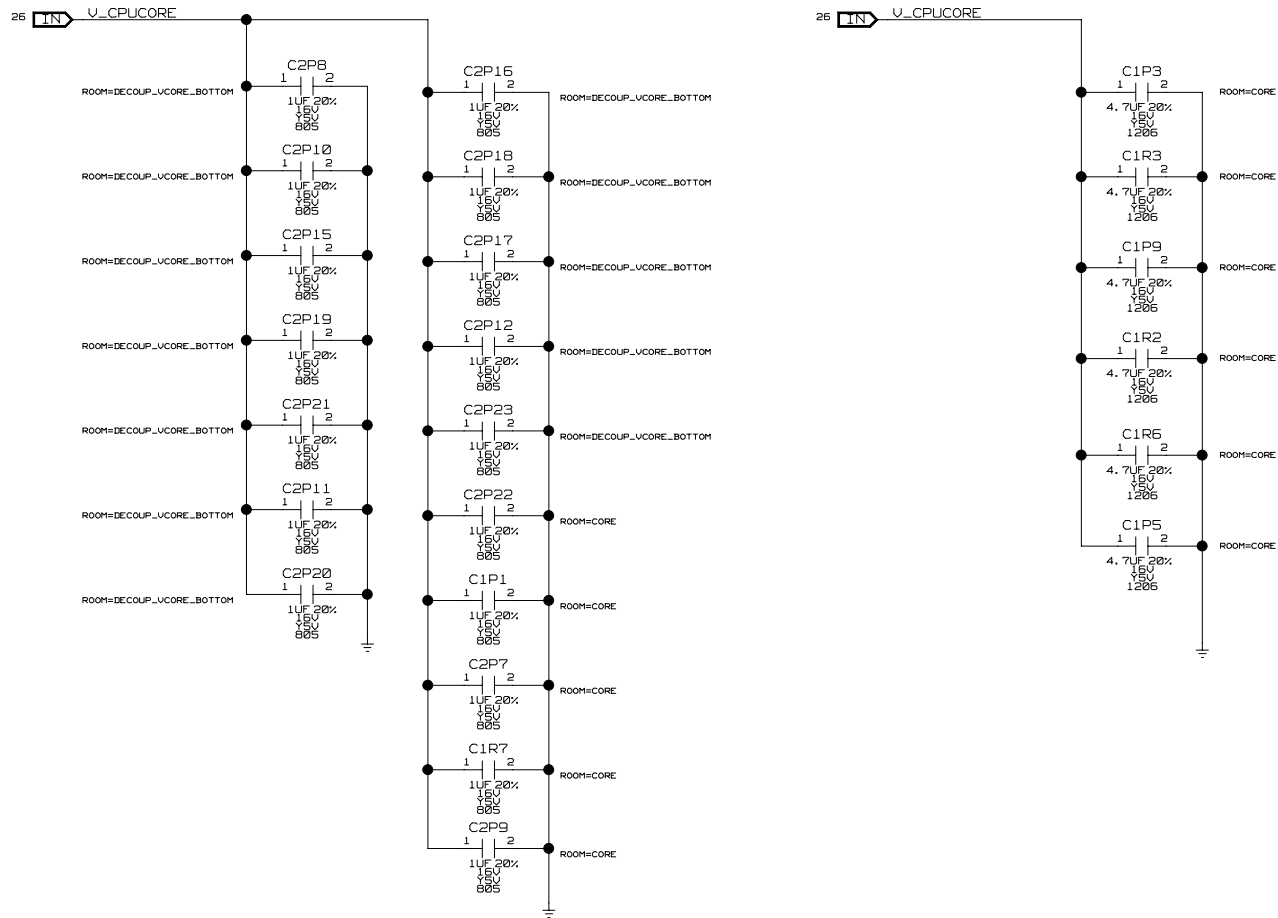

[PAGE\_TITLE=CPU VCORE DECOUPLING]

DRAWING  
 DUTFABP\_SCH\_11\_8  
 Fri May 03 11:23:38 2002

INTEL CONFIDENTIAL	DOCUMENT NUMBER XXXXXX	PAGE 8	REV 12.0
-----------------------	---------------------------	-----------	-------------



CPU VTT DECOUPLING

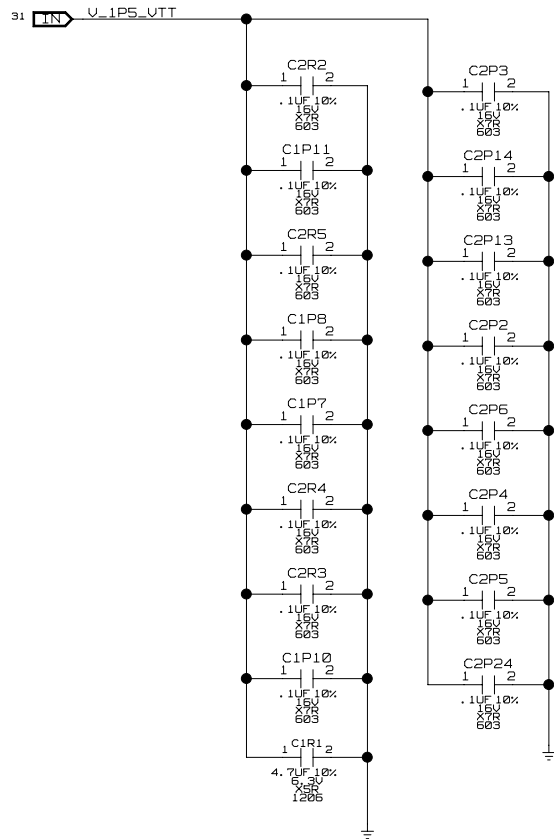

[PAGE\_TITLE=CPU VTT DECOUPLING]

DRAWING  
 DUTFABP\_SCH\_11\_9  
 Fri May 03 11:23:39 2002

INTEL CONFIDENTIAL	DOCUMENT NUMBER XXXXXX	PAGE 9	REV 12.0
-----------------------	---------------------------	-----------	-------------

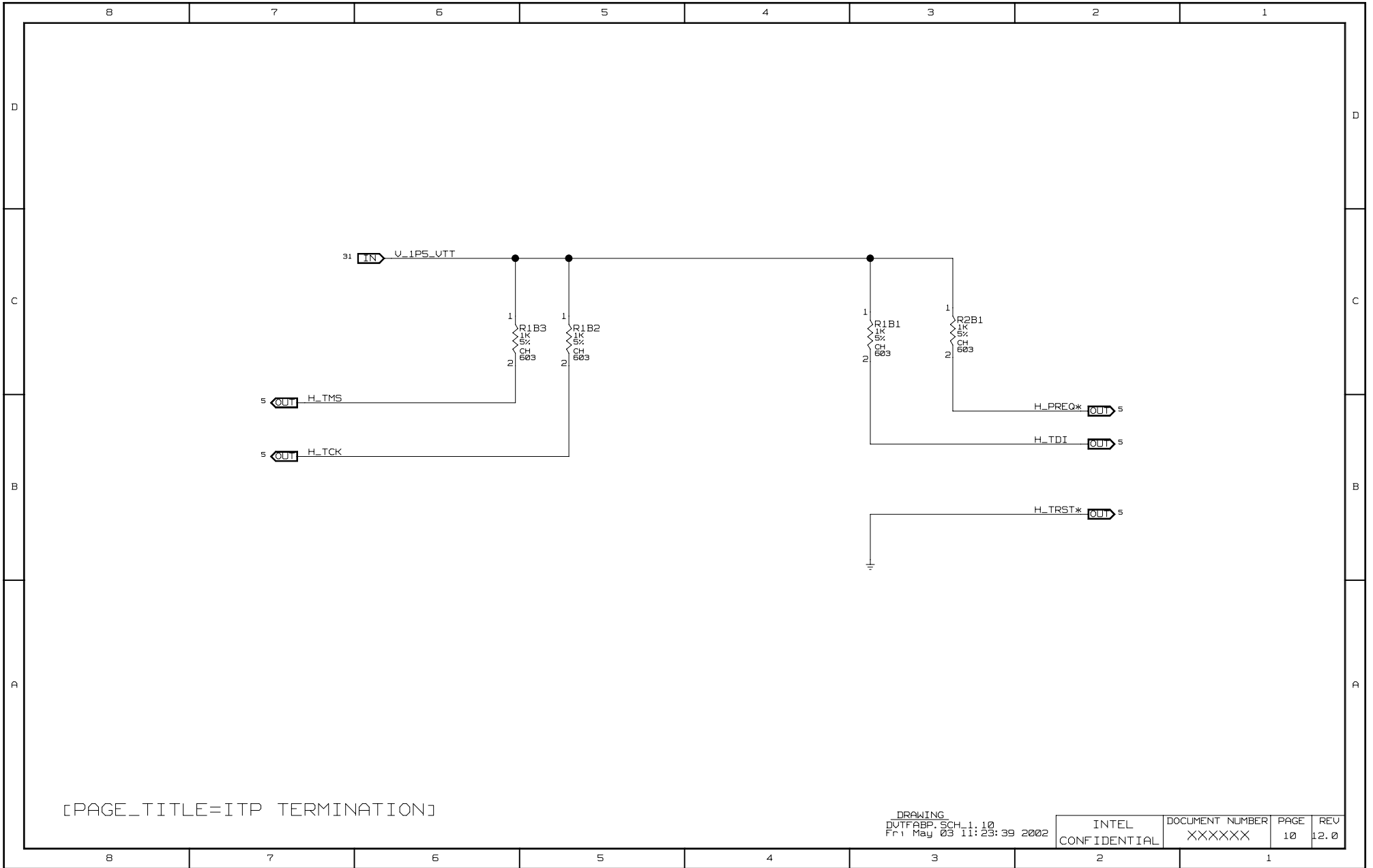

[PAGE\_TITLE=ITP TERMINATION]

DRAWING  
 DUTFABP\_SCH\_1\_10  
 Fri May 03 11:23:39 2002

INTEL CONFIDENTIAL	DOCUMENT NUMBER XXXXXX	PAGE 10	REV 12.0
-----------------------	---------------------------	------------	-------------

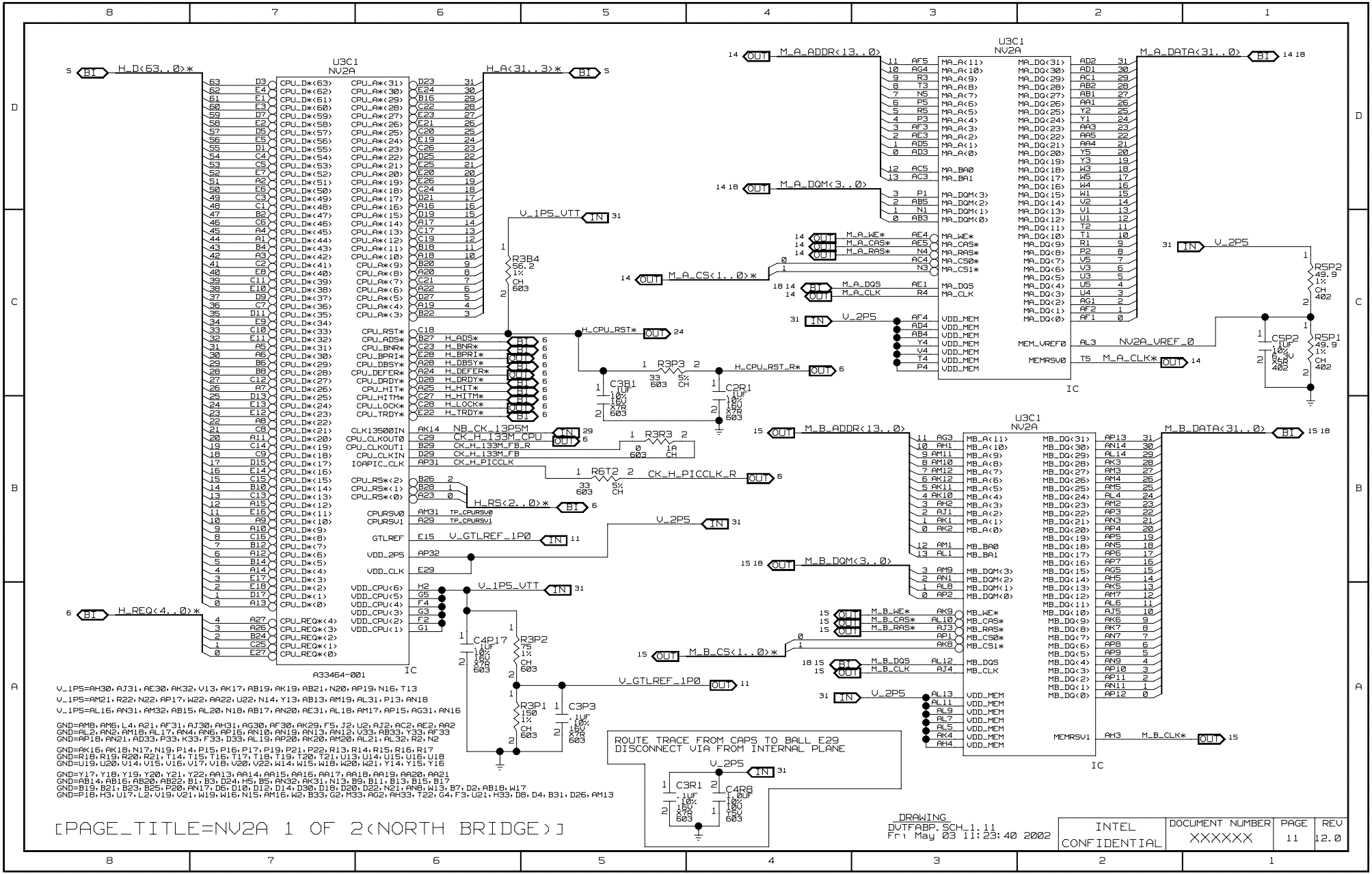

DRAWING  
DVT/ASP\_SCH 11:11  
Fri May 03 11:23:40 2002

INTEL CONFIDENTIAL	DOCUMENT NUMBER XXXXXX	PAGE 11	REV 12.0
-----------------------	---------------------------	------------	-------------

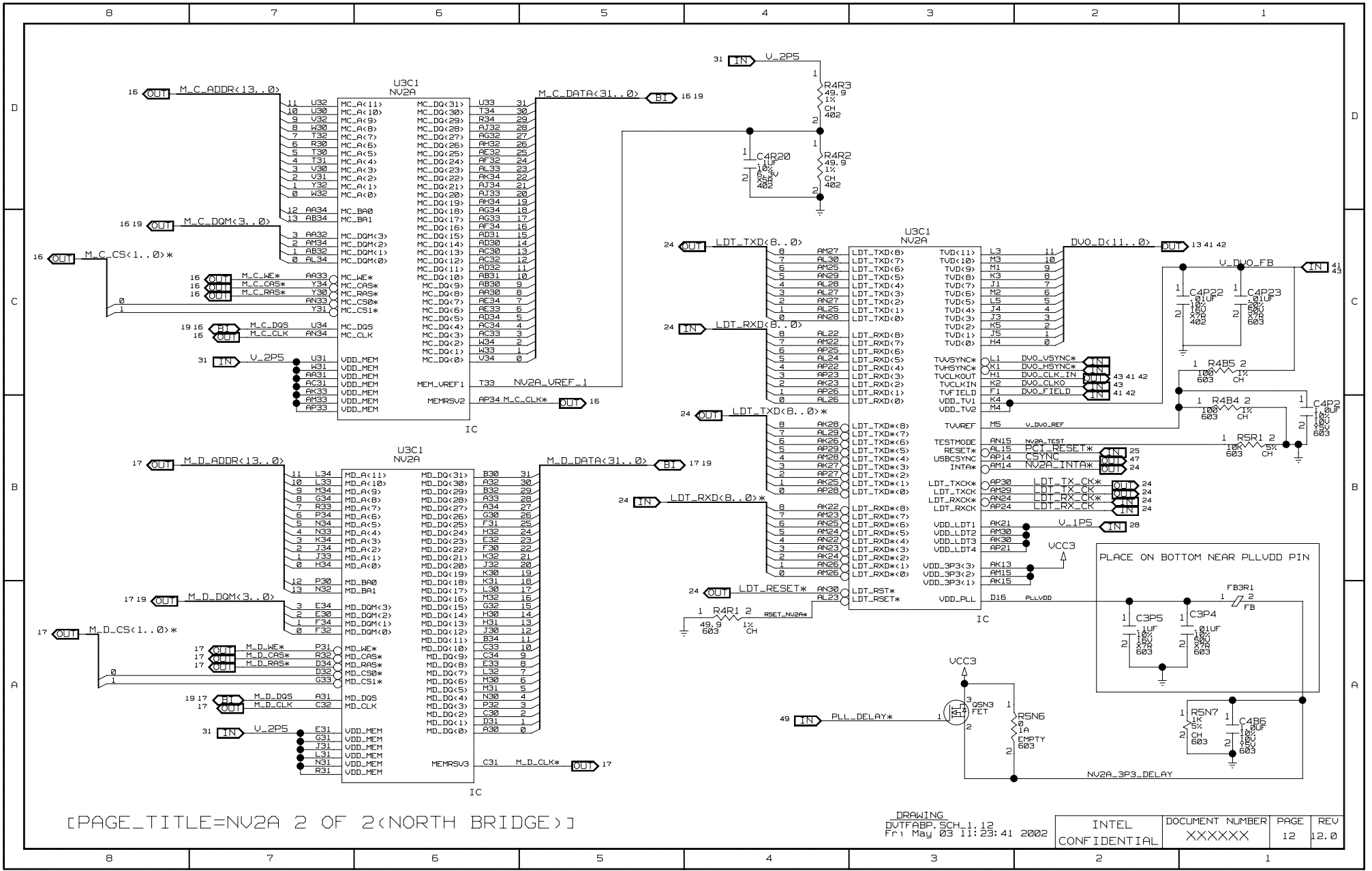

[PAGE\_TITLE=NV2A 2 OF 2<NORTH BRIDGE>]

DRAWING  
DUTFABP\_SCH 11:12  
Fr 1 May 03 11:23:41 2002

INTEL CONFIDENTIAL	DOCUMENT NUMBER XXXXXX	PAGE 12	REV 12.0
-----------------------	---------------------------	------------	-------------

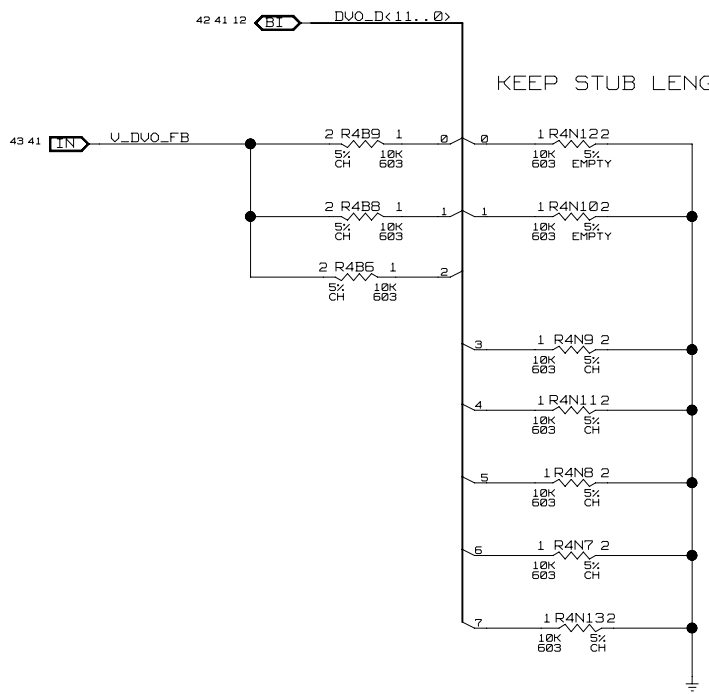

TVD		DEFINITION
[7]	0* 1	ENABLE INTERNAL LDT TERMINATION DISABLE INTERNAL LDT TERMINATION
[6]	0* 1	13.5MHZ OR 16.6MHZ 14.31818MHZ
[5:4]	00* 01 10 11	USE FSB FREQUENCY BASED ON TVD[3:2] USE INTERNAL PROGRAMMED VALUE A USE INTERNAL PROGRAMMED VALUE B FORCE 65MHZ
[3:2]	00 01* 10 11	NA FSB FREQ=133MHZ FOR 16.6MHZ INPUT CLK NA NA
[1:0]	00* 01 10 11	EMRS MICRON MATCHED MODE EMRS [6,1]=[0,1], HALF OF NORMAL DRIVE MODE RESERVED EMRS MATCHED 30% DRIVE MODE<SAMSUNG>

\* = CURRENT SETTING

FOR SAMSUNG DDR:  
EMPTY R4N10 AND R4N12  
STUFF R4B8 AND R4B9

# MEMORY INTERFACE PARTITION A

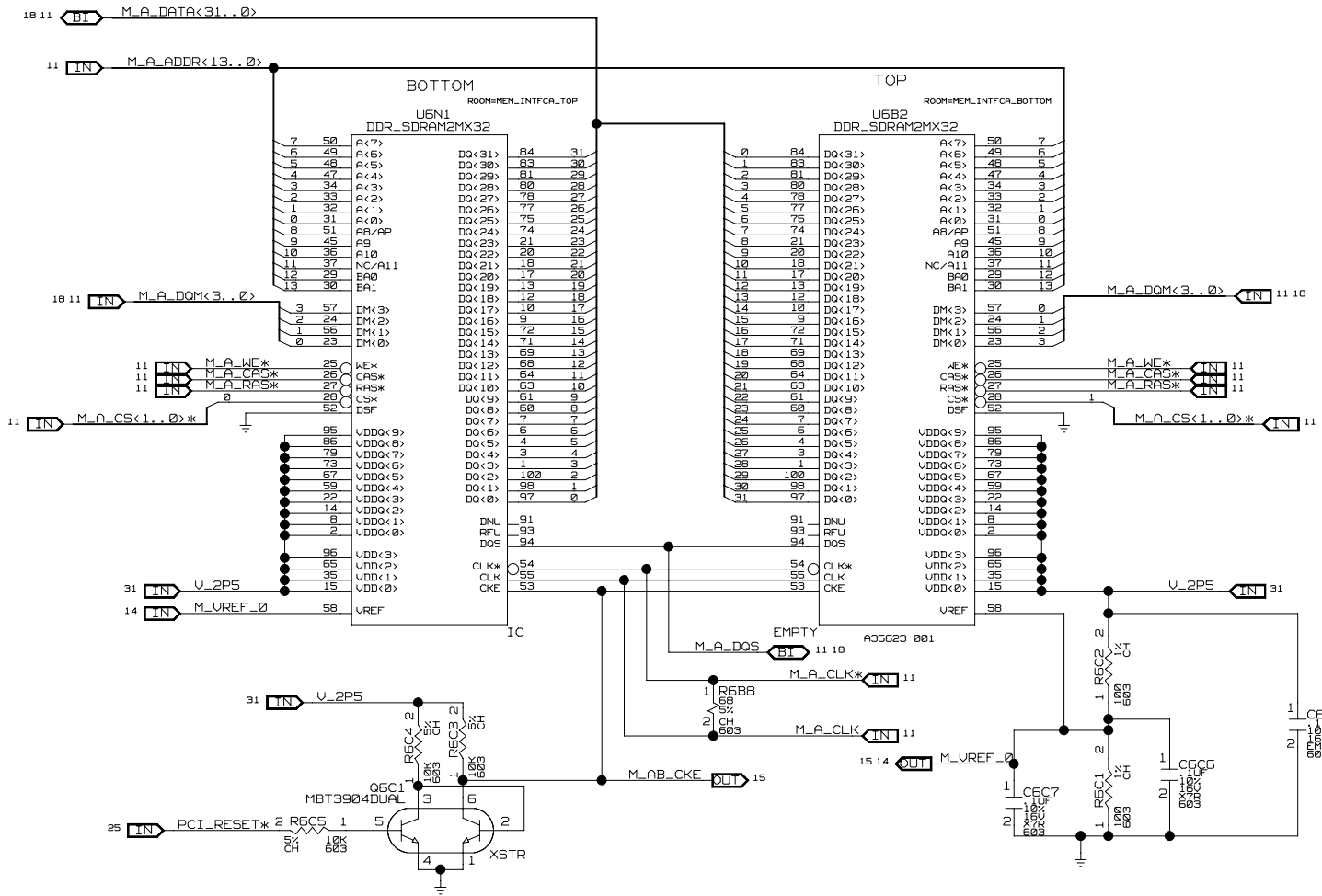

[PAGE\_TITLE=DDR SDRAM (PARTITION A)]

DRAWING  
DVT/FAB SCH 11:14  
Fr 1 May 03 11:23:42 2002

INTEL CONFIDENTIAL	DOCUMENT NUMBER XXXXXX	PAGE 14	REV 12.0
-----------------------	---------------------------	------------	-------------

# MEMORY INTERFACE PARTITION B

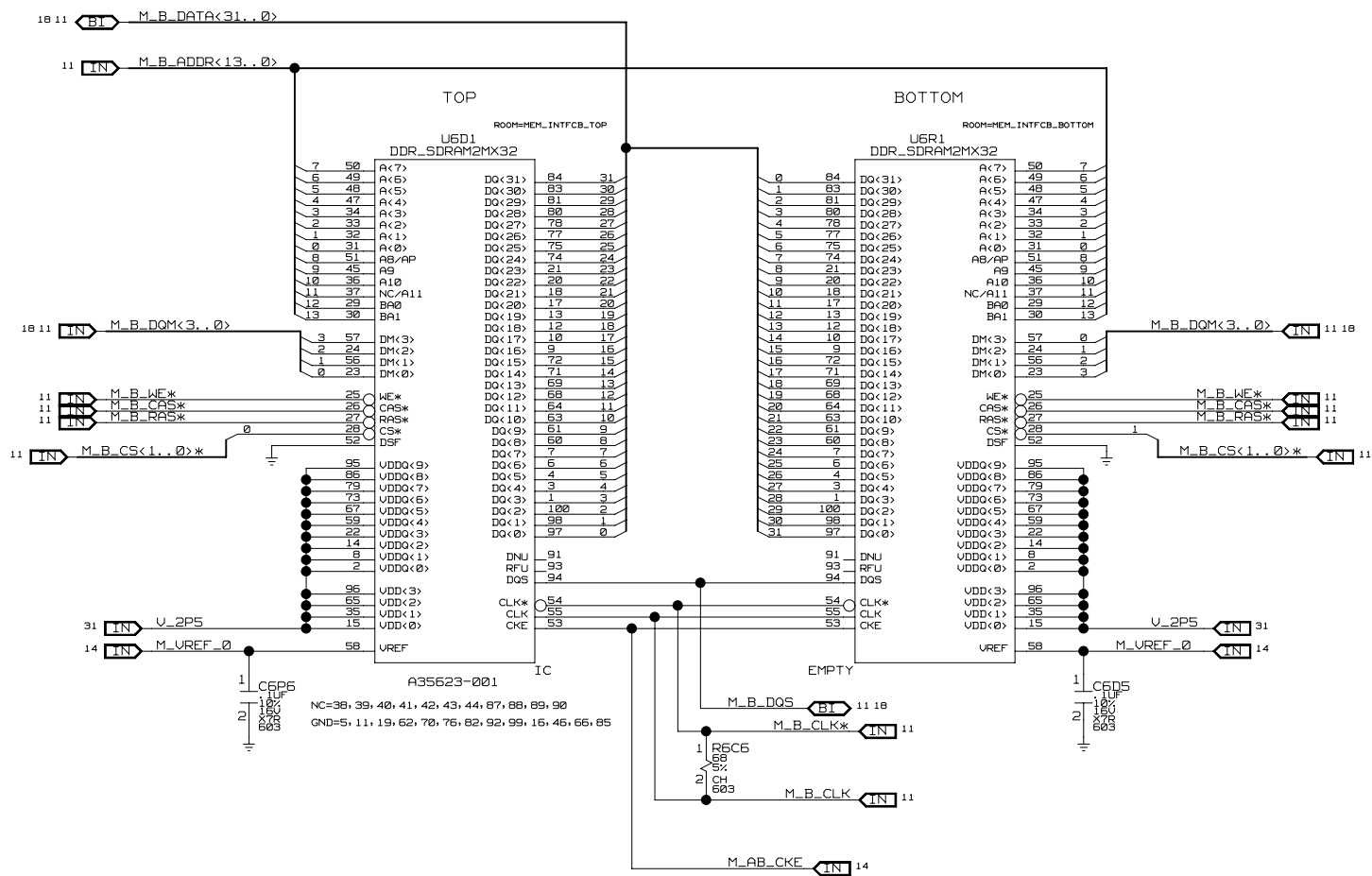

[PAGE\_TITLE=DDR SDRAM (PARTITION B)]

DRAWING  
DVT/FABP\_SCH 11:15  
Fri May 03 11:23:43 2002

INTEL	DOCUMENT NUMBER	PAGE	REV
CONFIDENTIAL	XXXXXX	15	12.0

# MEMORY INTERFACE PARTITION C

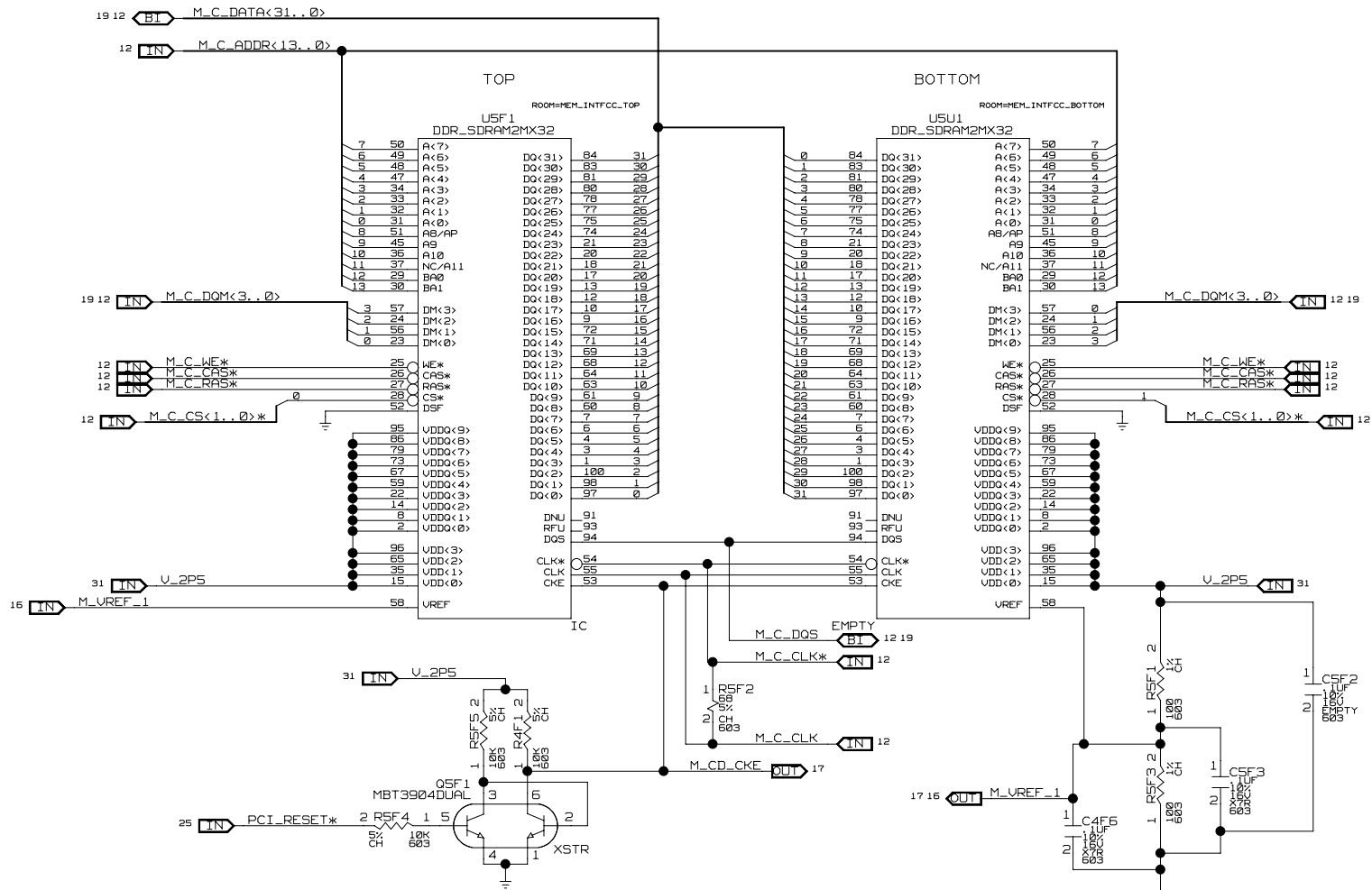

[PAGE\_TITLE=DDR SDRAM (PARTITION C)]

DRAWING  
DVT/FAB SCH 11:16  
Fr 1 May 03 11:23:44 2002

INTEL CONFIDENTIAL	DOCUMENT NUMBER XXXXXX	PAGE 16	REV 12.0
-----------------------	---------------------------	------------	-------------



MEMORY INTERFACE PARTITION D

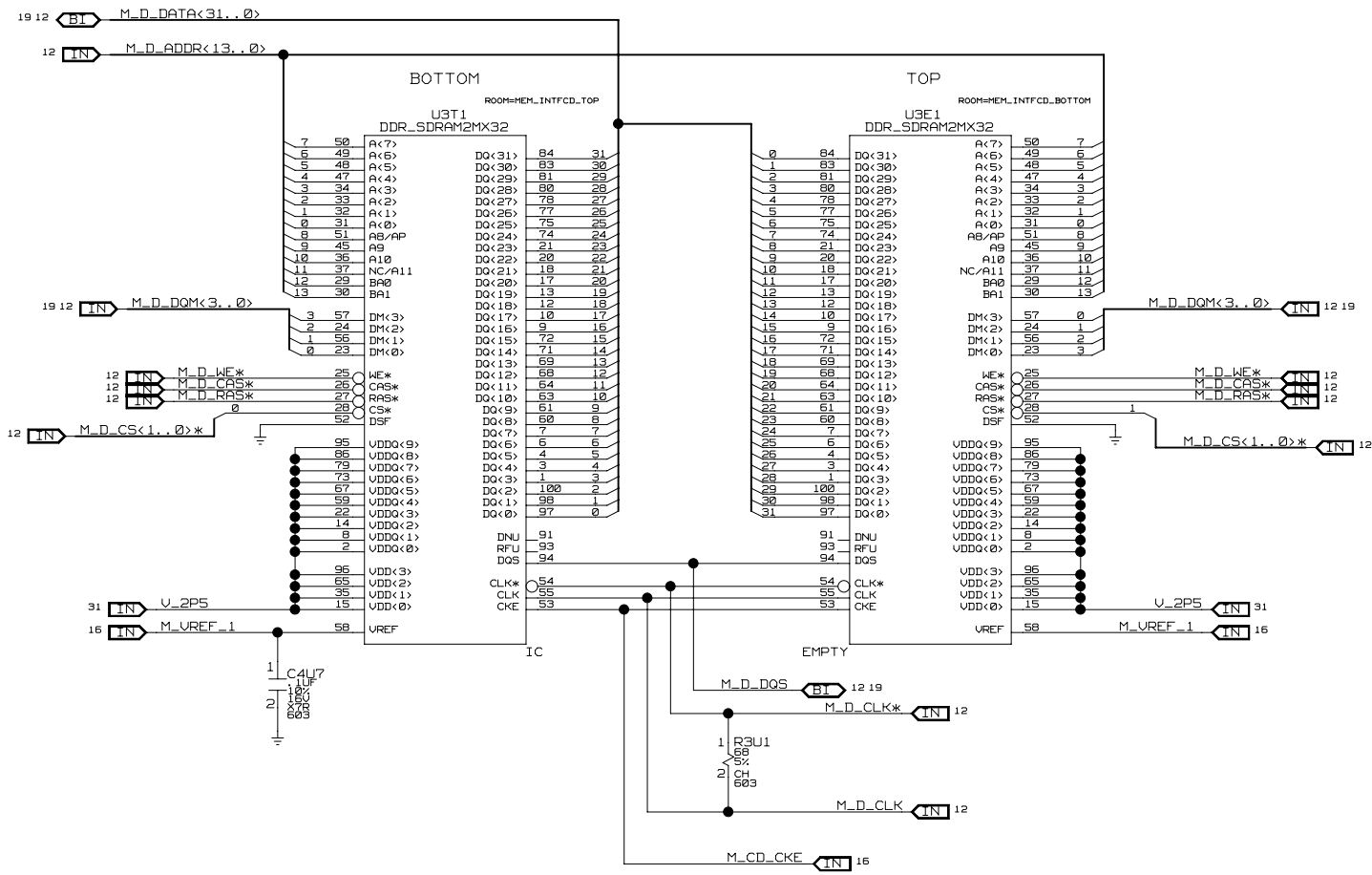

[PAGE\_TITLE=DDR SDRAM (PARTITION D)]

DRAWING  
DVTFABP\_SCH\_117  
Fri May 03 11:23:45 2002

INTEL	DOCUMENT NUMBER	PAGE	REV
CONFIDENTIAL	XXXXXX	17	12.0

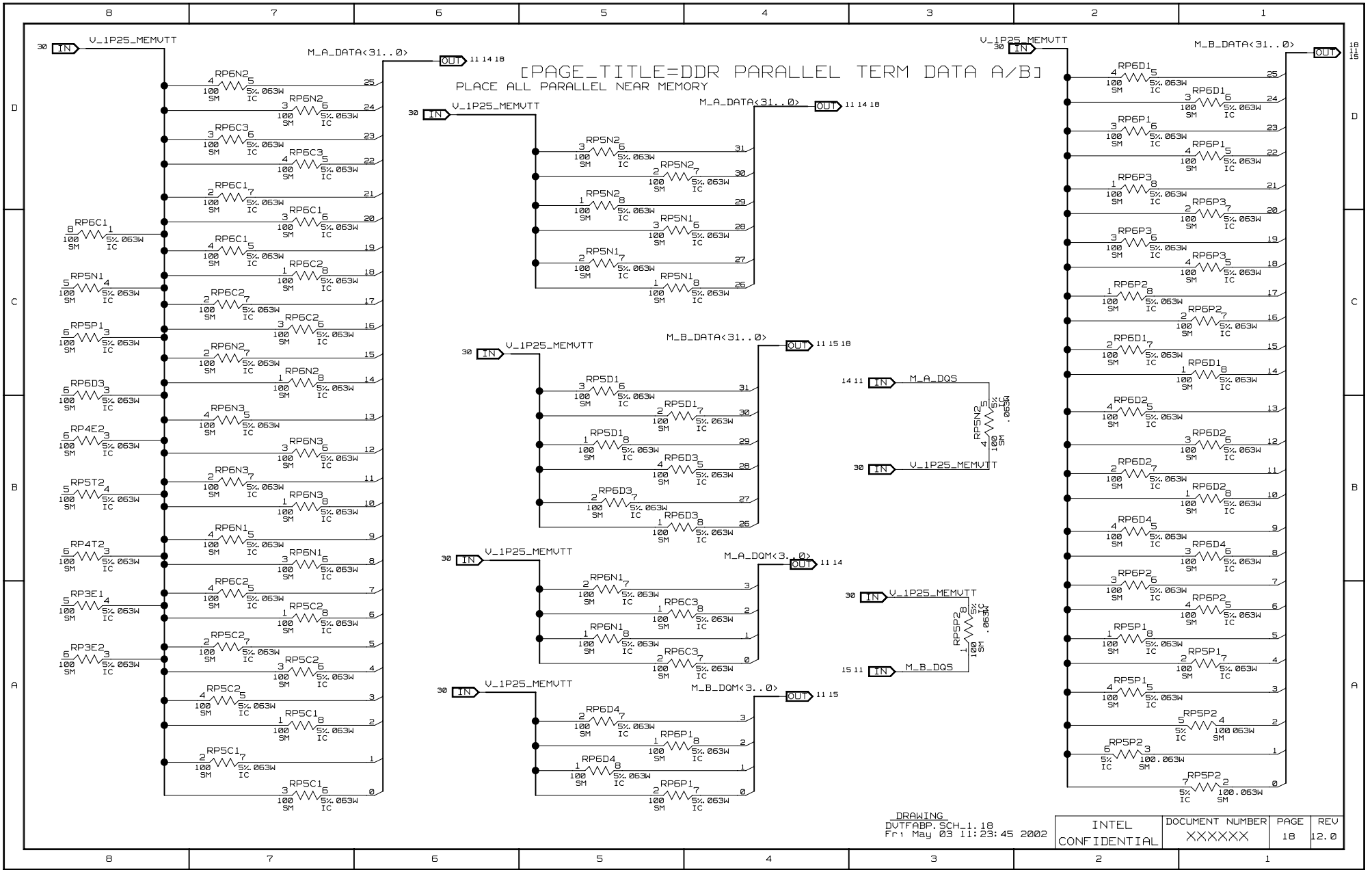

INTEL CONFIDENTIAL	DOCUMENT NUMBER XXXXXX	PAGE 18	REV 12.0
-----------------------	---------------------------	------------	-------------

[PAGE\_TITLE=DDR PARALLEL TERM DATA C/D]

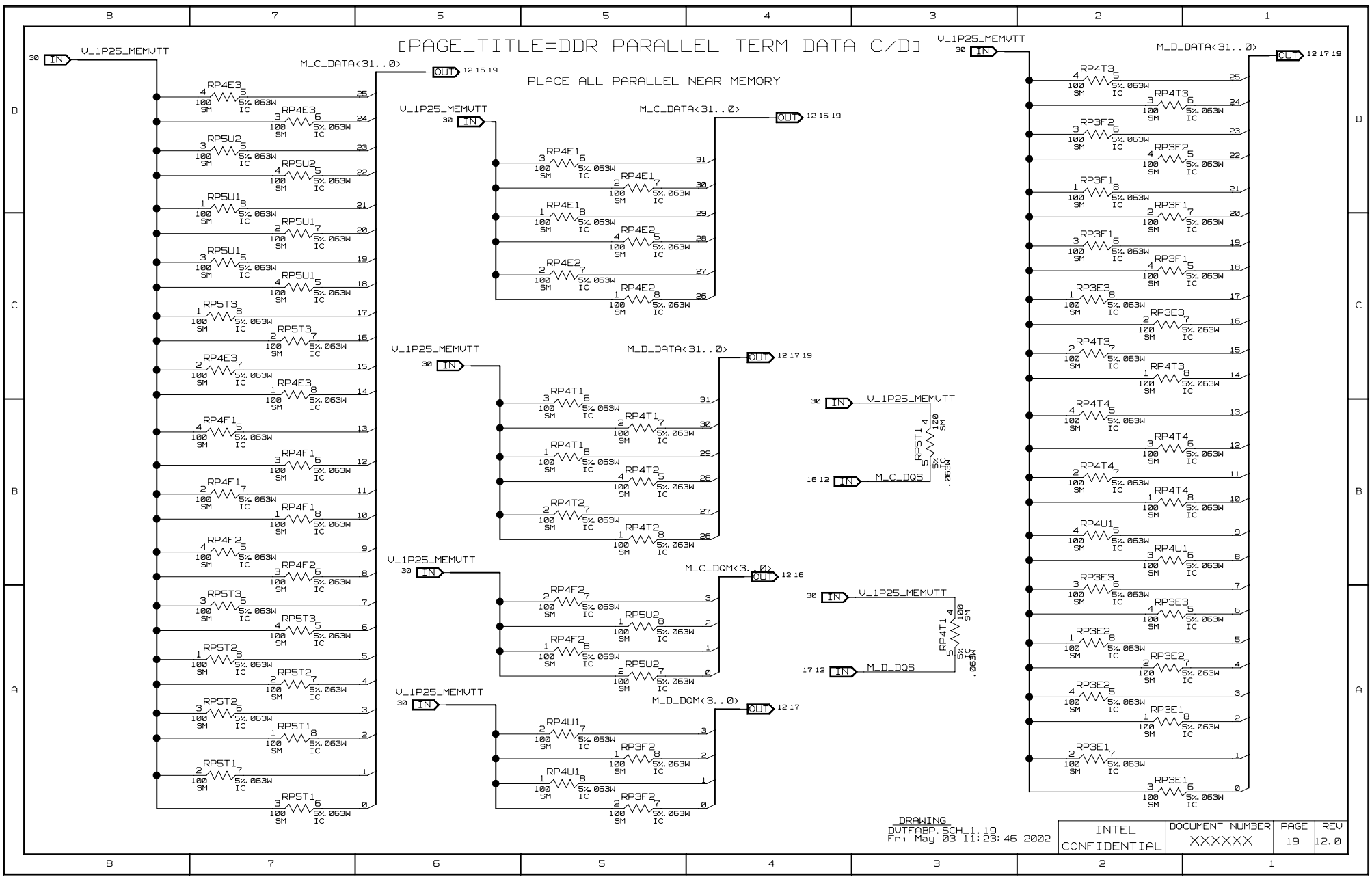

INTEL	DOCUMENT NUMBER	PAGE	REV
CONFIDENTIAL	XXXXXX	19	12.0

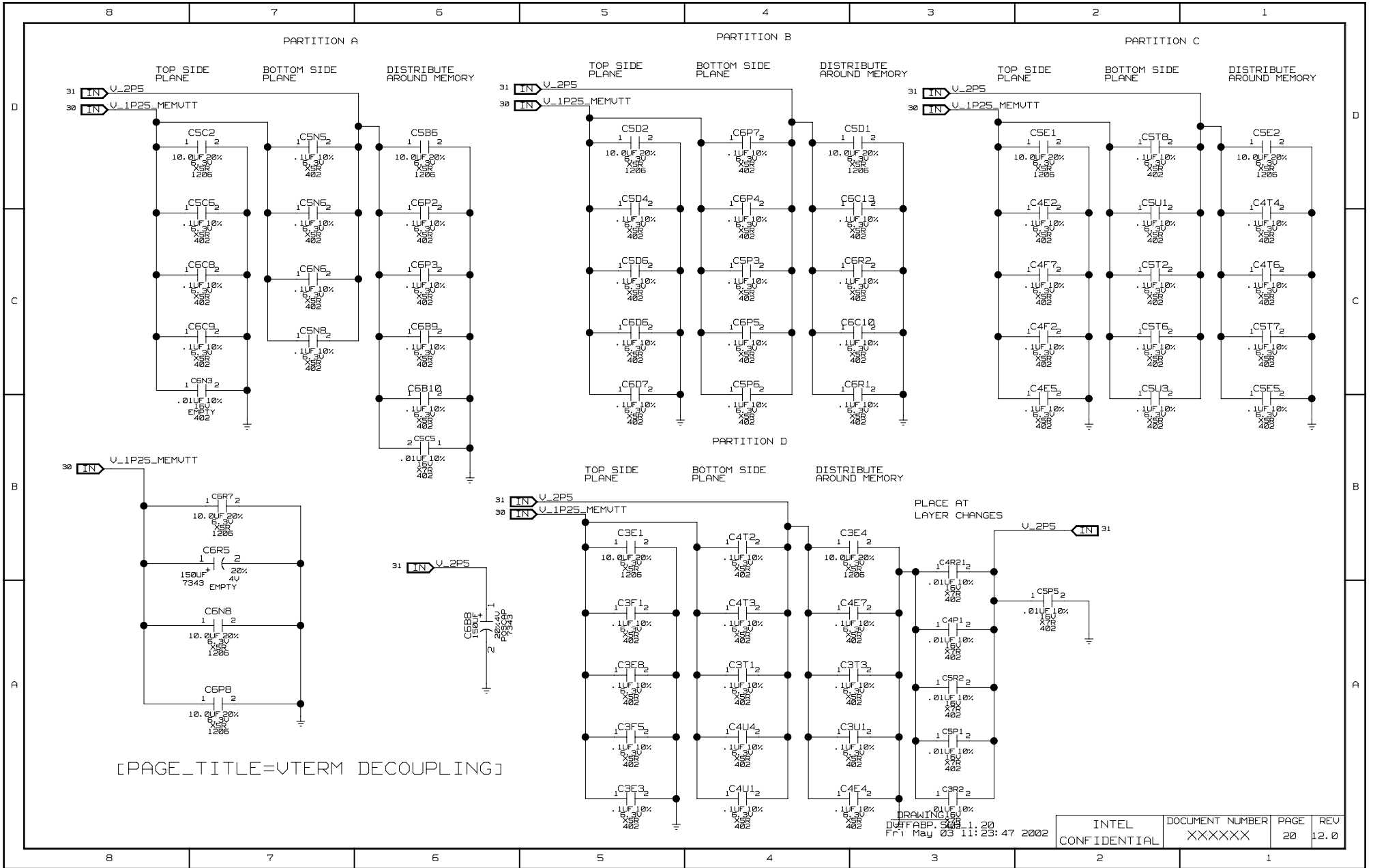

[PAGE\_TITLE=VTERM DECOUPLING]

DRAWING 153  
 DATE: 05/03/02  
 Fr 11:23:47 2002

INTEL	DOCUMENT NUMBER	PAGE	REV
CONFIDENTIAL	XXXXXX	20	12.0

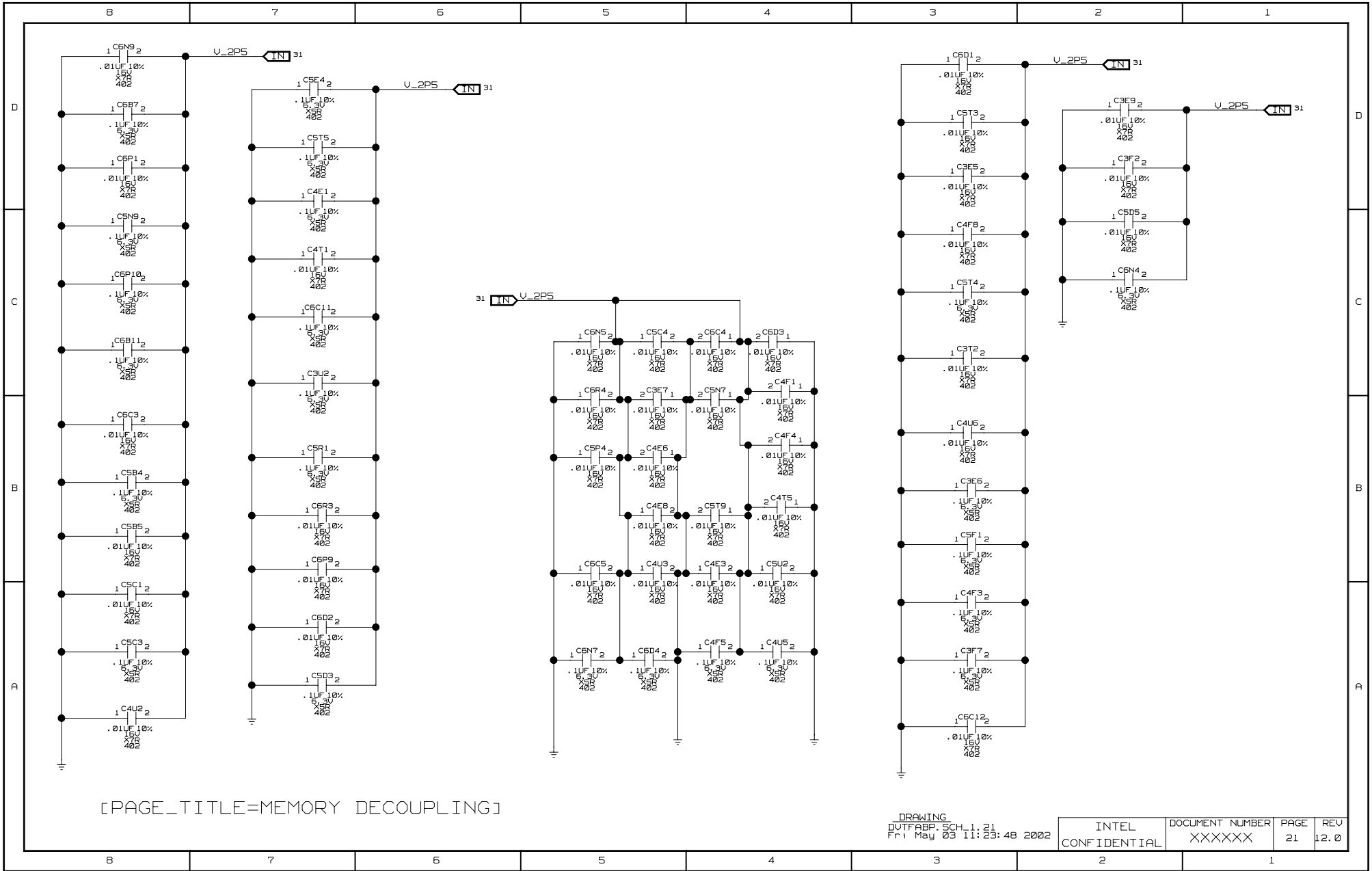

[PAGE\_TITLE=MEMORY DECOUPLING]

DRAWING  
 DUTFABP\_SCH\_11\_21  
 Fri May 03 11:23:48 2002

INTEL	DOCUMENT NUMBER	PAGE	REV
CONFIDENTIAL	XXXXXX	21	12.0

# NV2A DECOUPLING

CHANGE COMPONENT  
TO CHEAPER PART.

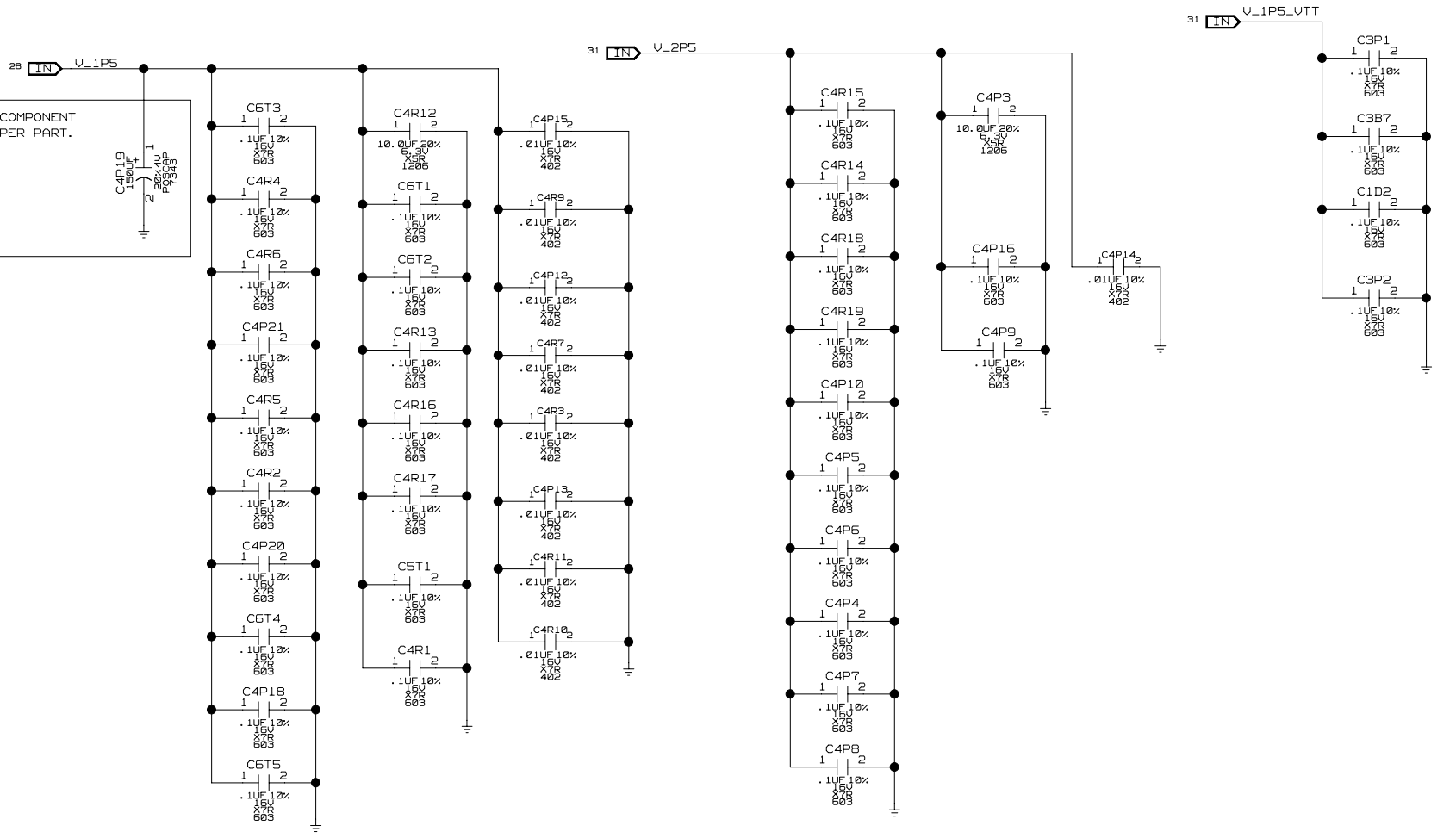

[PAGE\_TITLE=NV2A DECOUPLING]

DRAWING  
DVTFABP\_SCH\_11:22  
Fri May 03 11:23:49 2002

INTEL	DOCUMENT NUMBER	PAGE	REV
CONFIDENTIAL	XXXXXX	22	12.0

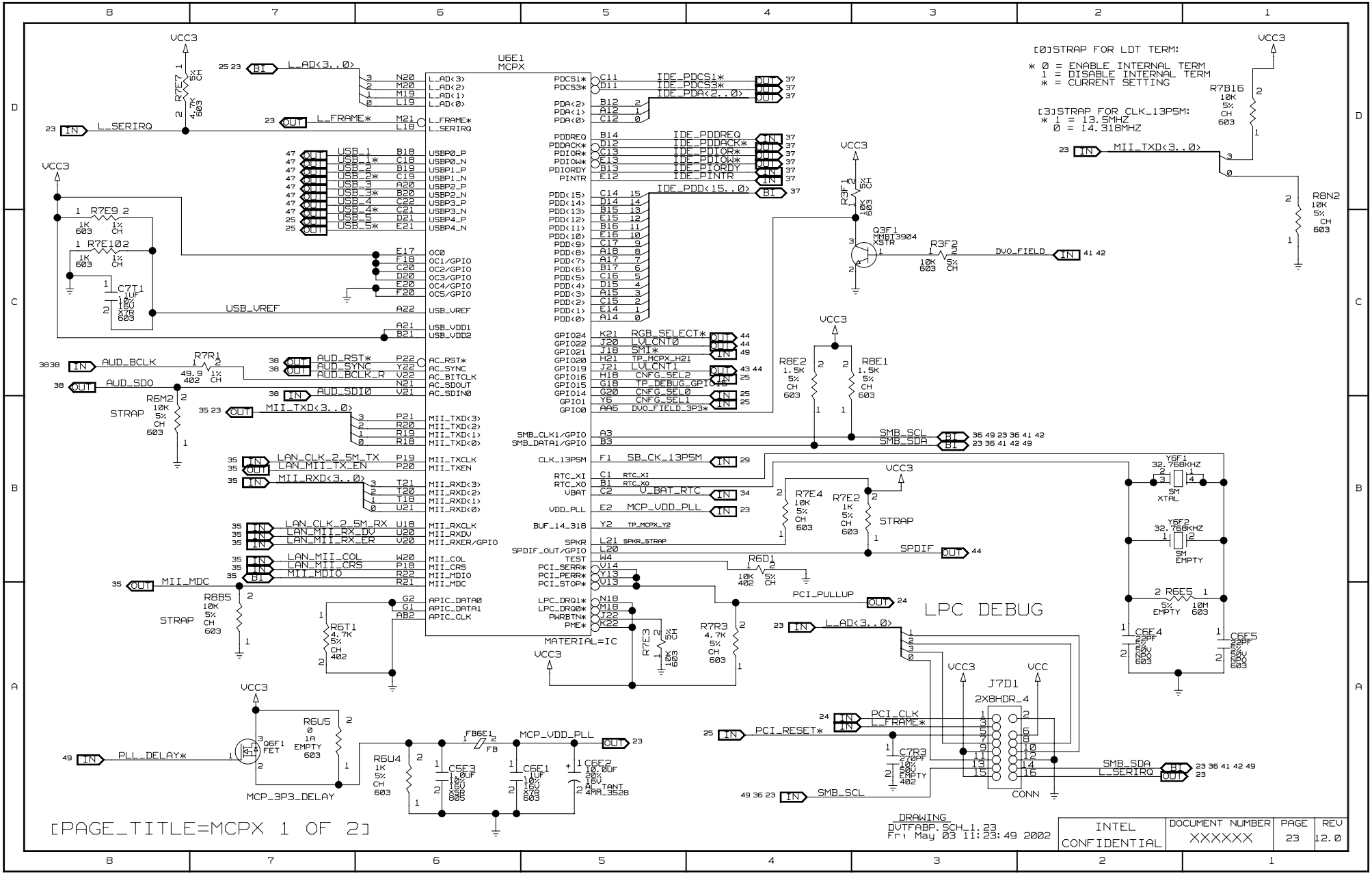

[PAGE\_TITLE=MCPX 1 OF 2]

DRAWING  
 DVT/FAB. SCH 11:23  
 Fri May 03 11:23:49 2002

INTEL	DOCUMENT NUMBER	PAGE	REV
CONFIDENTIAL	XXXXXX	23	12.0

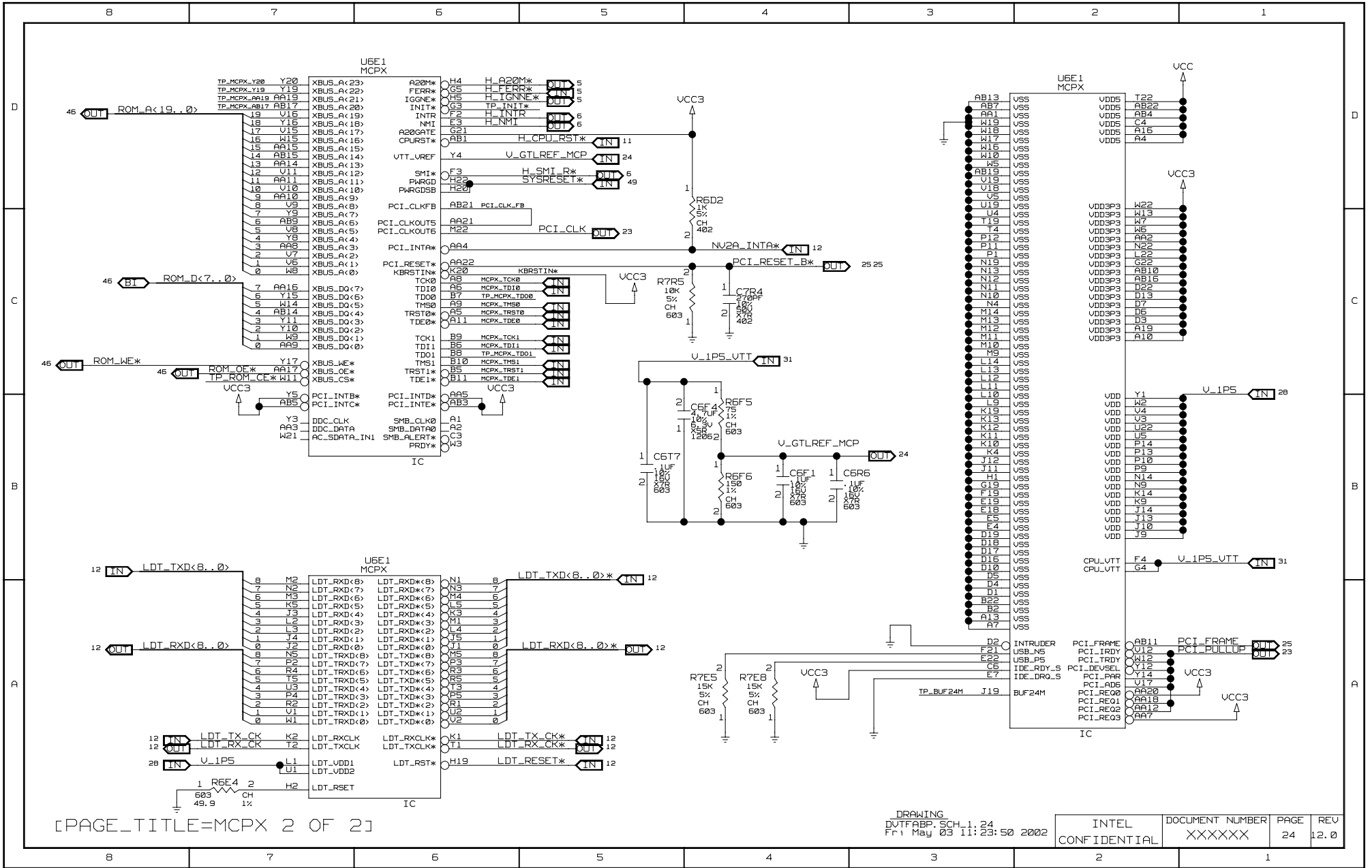



CNFG_SEL		DEFINITION
[0]	0 1*	AQUILA SAN ANTONIO
[1]	0* 1	UNDEFINED - DEFAULT UNDEFINED
[2]	0* 1	UNDEFINED - DEFAULT UNDEFINED

\* = CURRENT SETTING

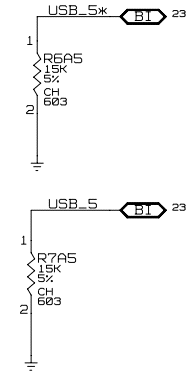
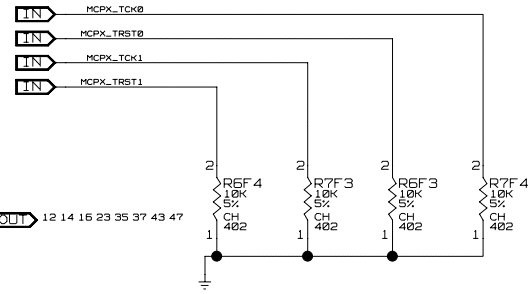
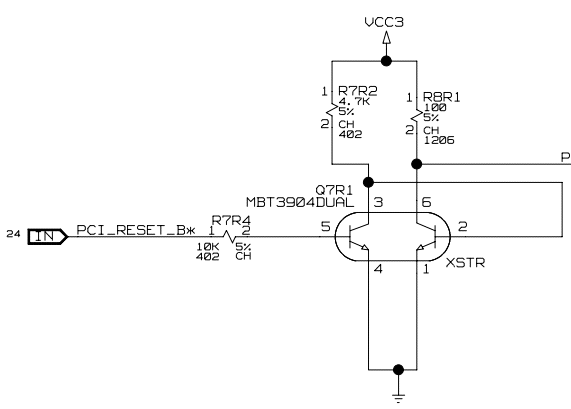
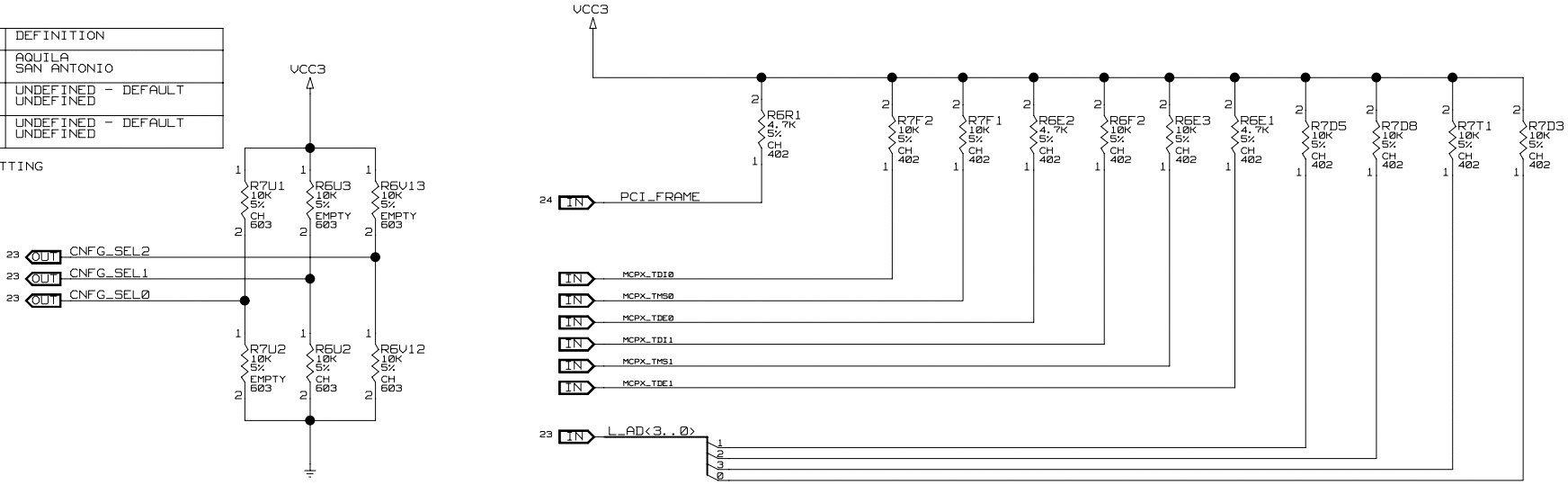

[PAGE\_TITLE=MCPX INPUT STRAPS]

DRAWING  
DVTFABP\_SCH\_1:25  
Fri May 03 11:23:51 2002

INTEL CONFIDENTIAL	DOCUMENT NUMBER XXXXXX	PAGE 25	REV 12.0
-----------------------	---------------------------	------------	-------------

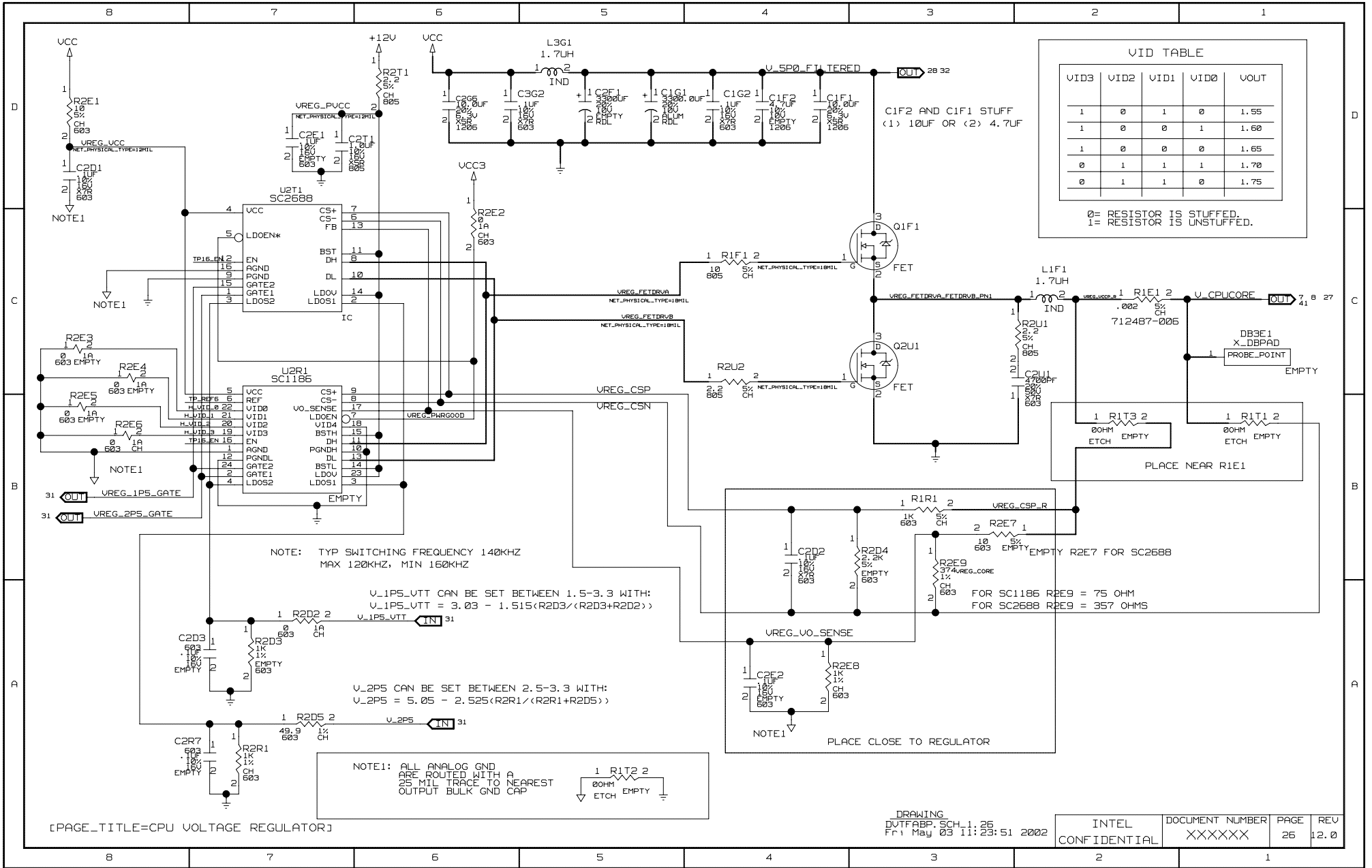

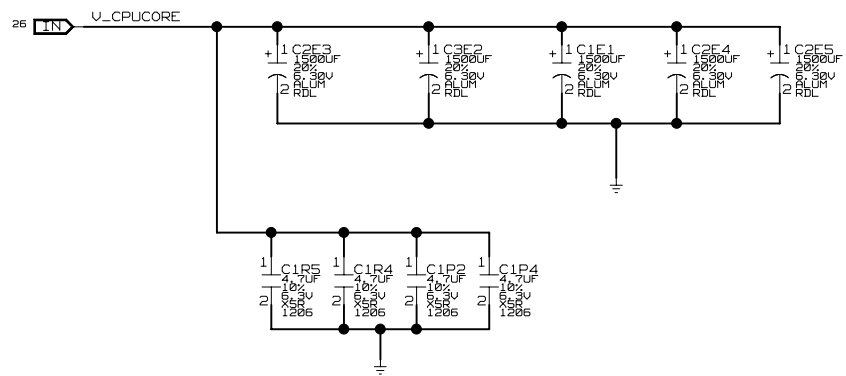

[PAGE\_TITLE=CPU VREG OUTPUT FILTER]

DRAWING  
DVTFABP\_SCH 11:27  
Fri May 03 11:23:52 2002

INTEL CONFIDENTIAL	DOCUMENT NUMBER XXXXXX	PAGE 27	REV 12.0
-----------------------	---------------------------	------------	-------------

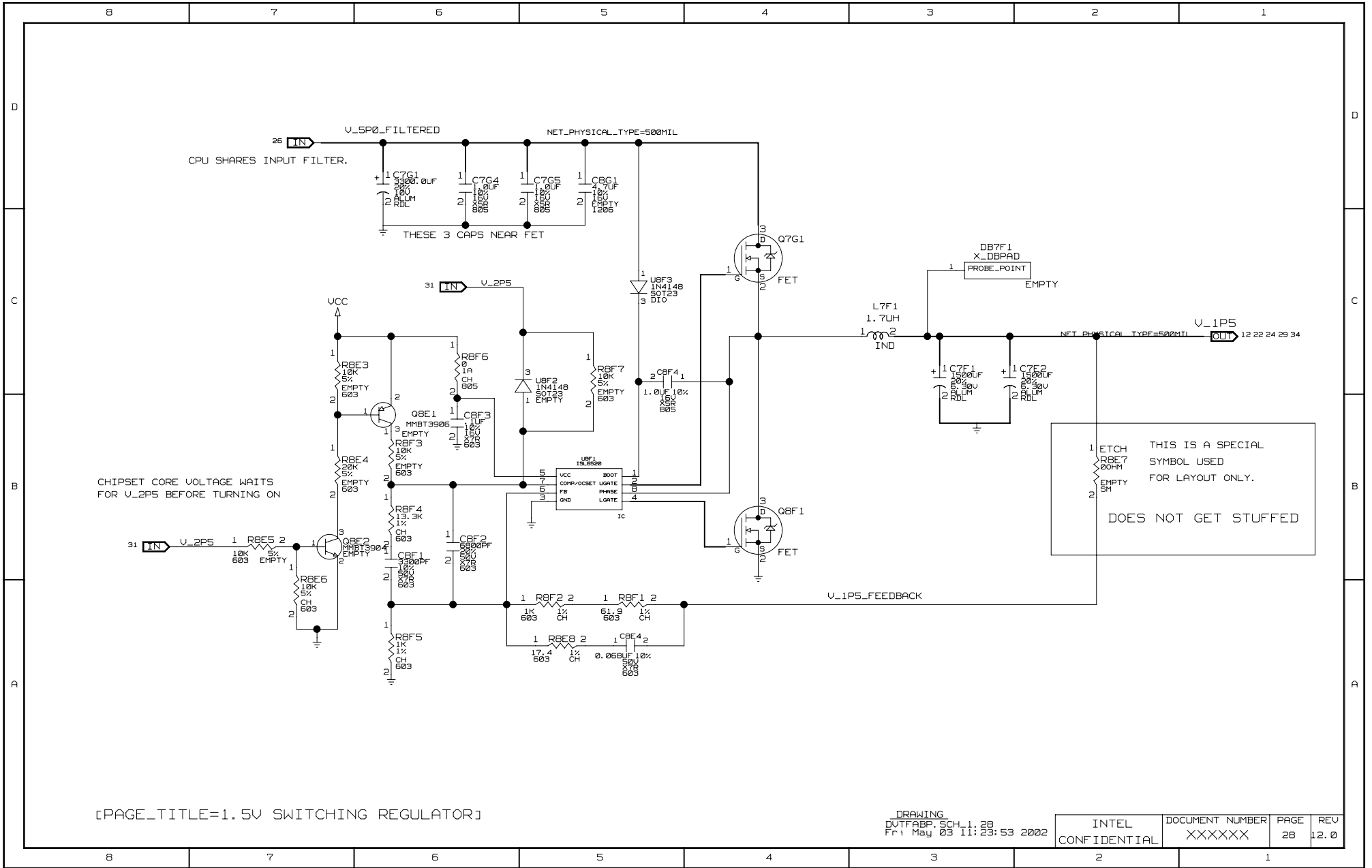

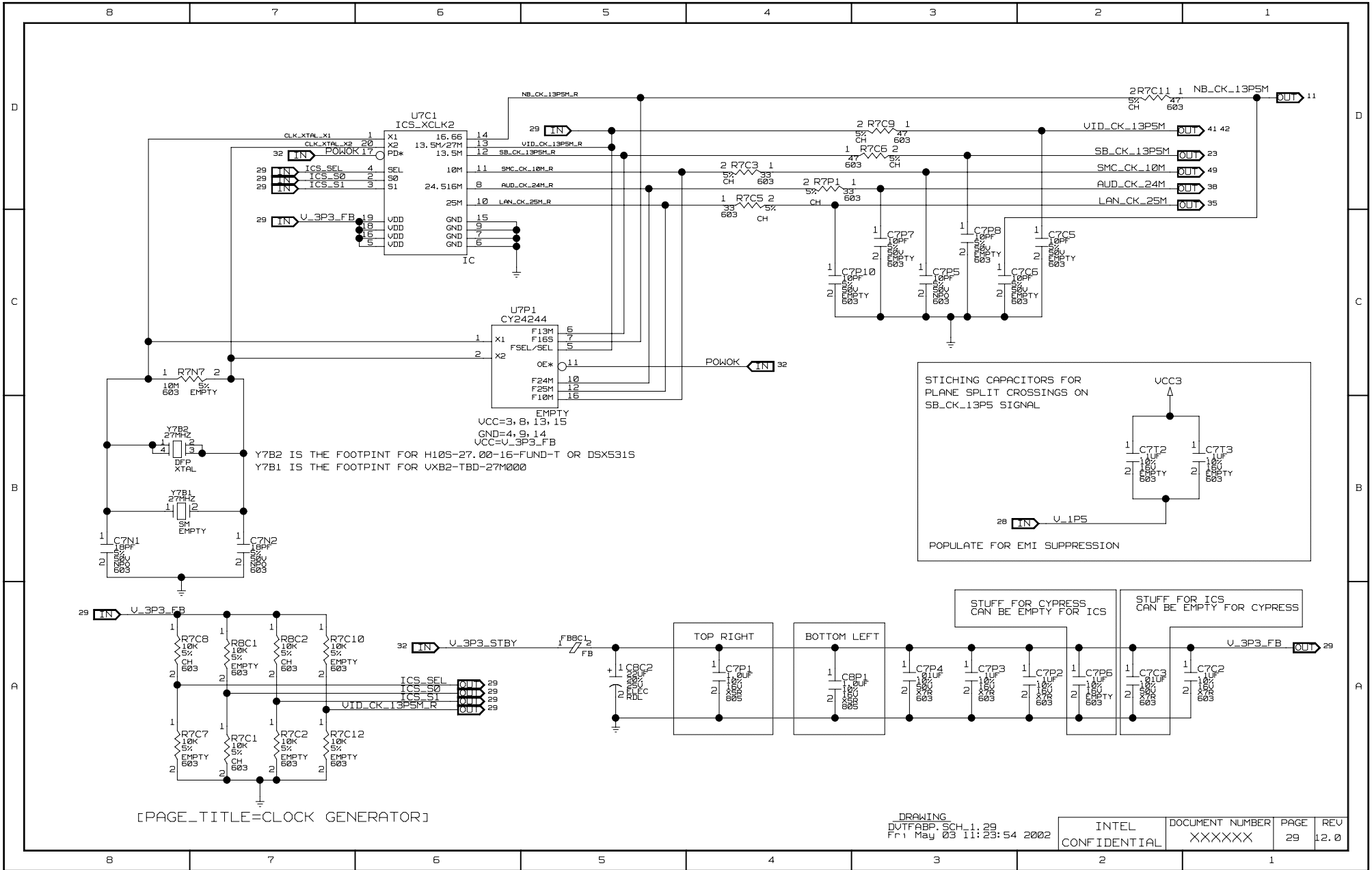

8 7 6 5 4 3 2 1

D

D

STUFF EITHER UCC3 OR UCC RESISTORS FOR DIFFERENT SEQUENCING

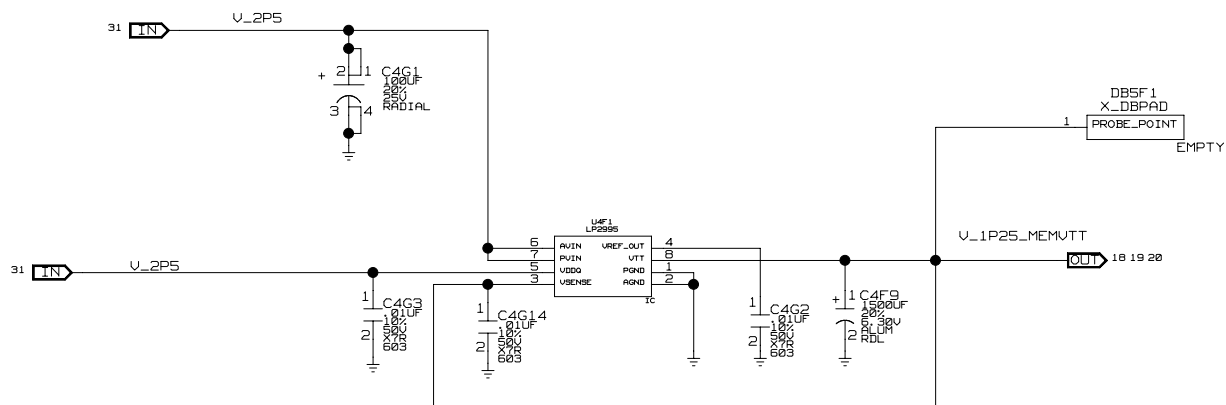

PLACE C301, C302, AND C303 NEAR REGULATOR PINS

[PAGE\_TITLE=1.25V LINEAR REGULATOR]

DRAWING  
DUTFABP\_SCH\_1\_30  
Pr: May 03 11:23:54 2002

INTEL CONFIDENTIAL	DOCUMENT NUMBER XXXXXX	PAGE 30	REV 12.0
-----------------------	---------------------------	------------	-------------

8 7 6 5 4 3 2 1

A

A

C

C

B

B

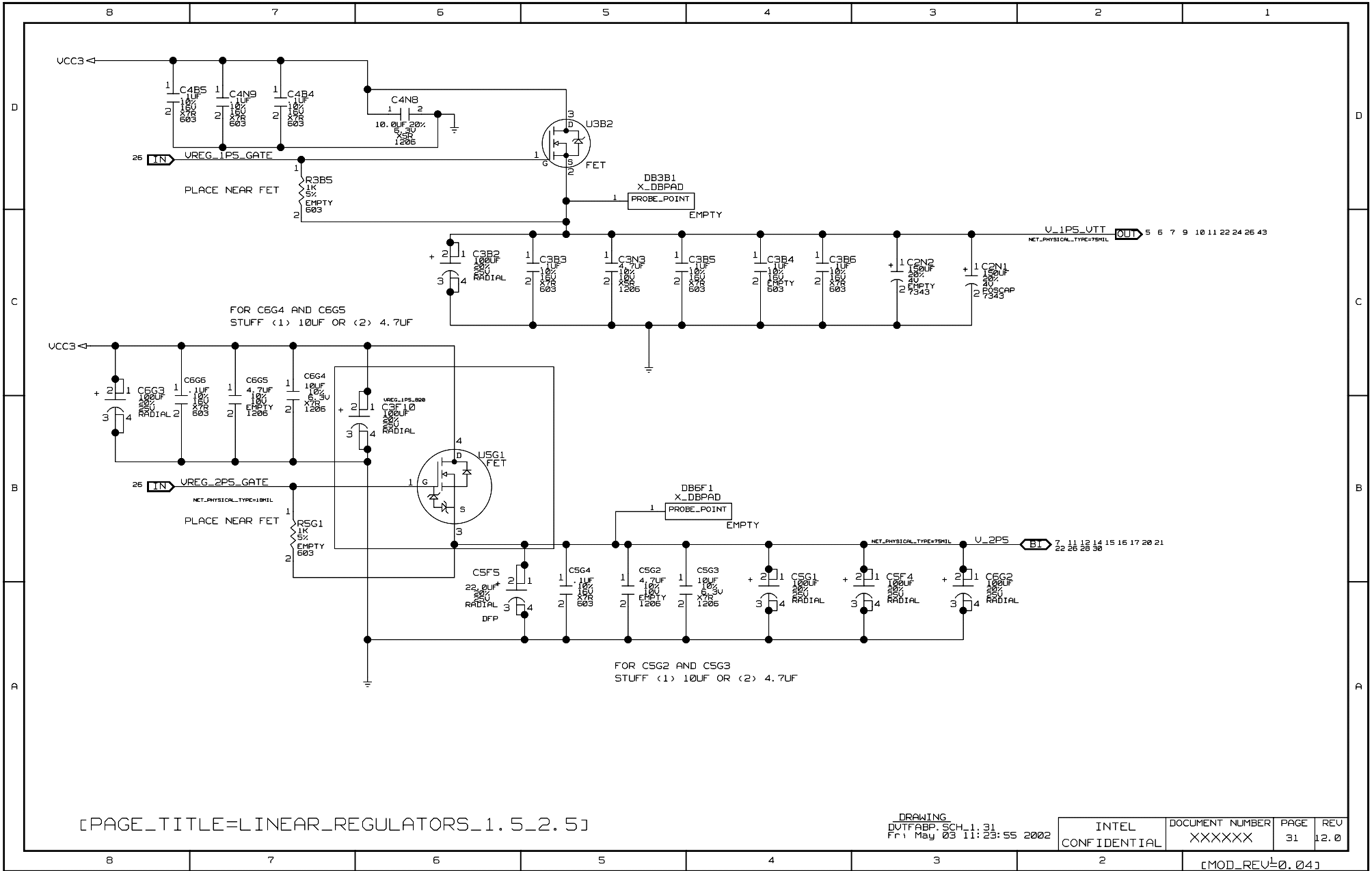

[PAGE\_TITLE=LINER\_REGULATORS\_1.5\_2.5]

DRAWING  
DVTFABP\_SCH\_11:31  
Fr: May 03 11:23:55 2002

INTEL CONFIDENTIAL	DOCUMENT NUMBER XXXXXX	PAGE 31	REV 12.0
-----------------------	---------------------------	------------	-------------

[MOD\_REV=0.04]

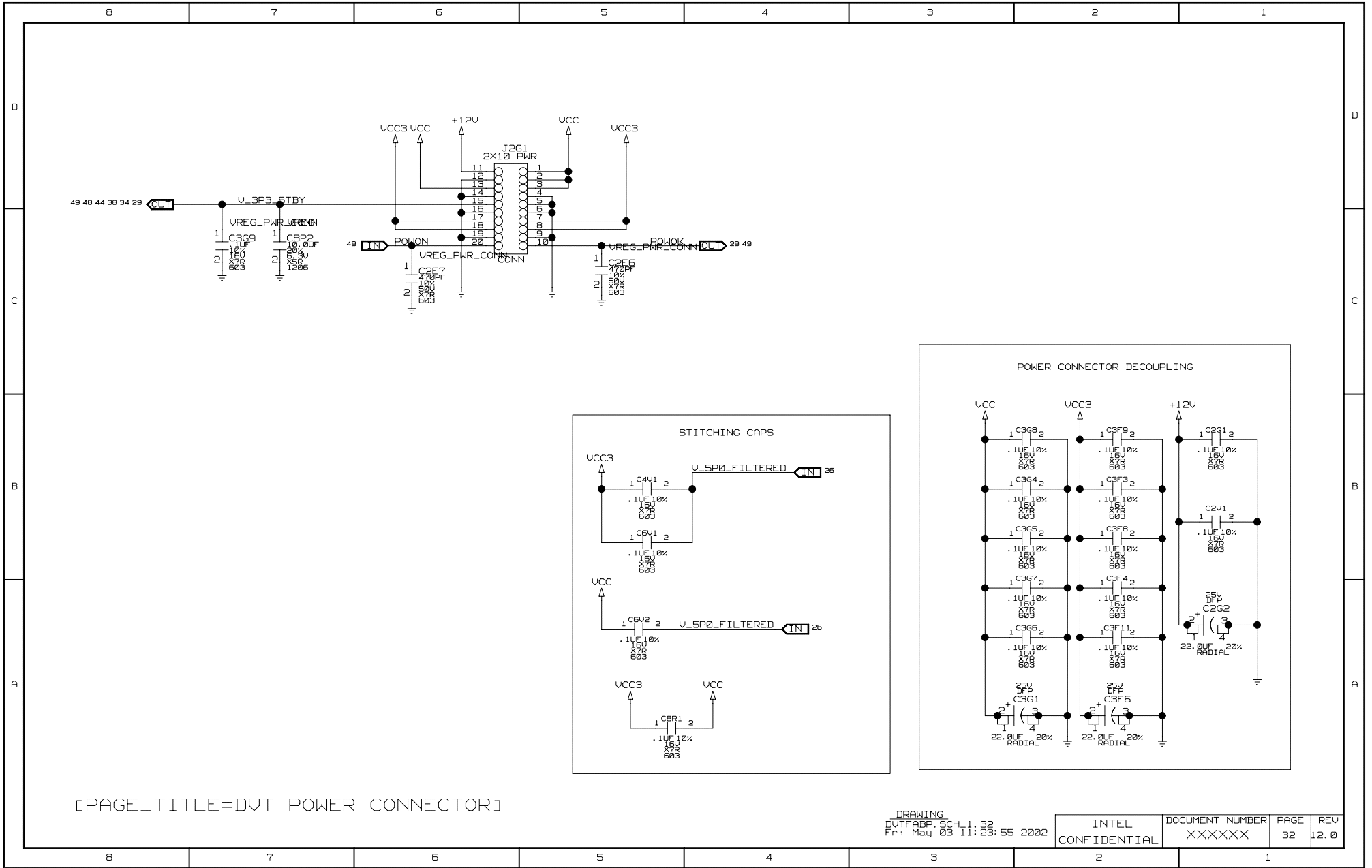

[PAGE\_TITLE=DVT POWER CONNECTOR]

DRAWING  
 DVTFABP\_SCH\_11:32  
 Fri May 03 11:23:55 2002

INTEL	DOCUMENT NUMBER	PAGE	REV
CONFIDENTIAL	XXXXXX	32	12.0



D

C

B

A

D

C

B

A

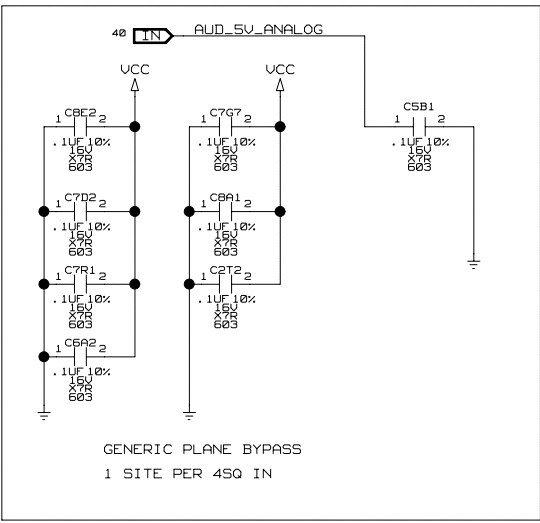
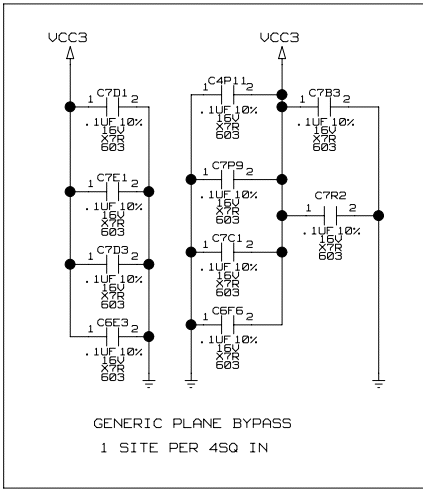
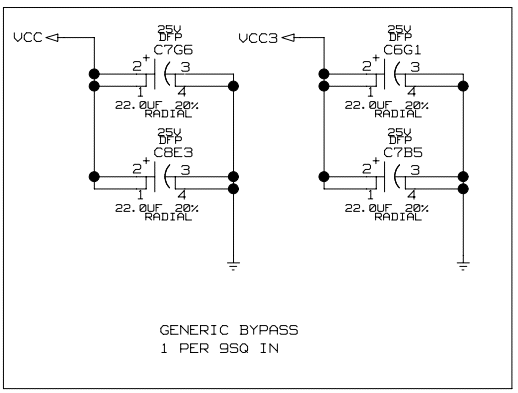
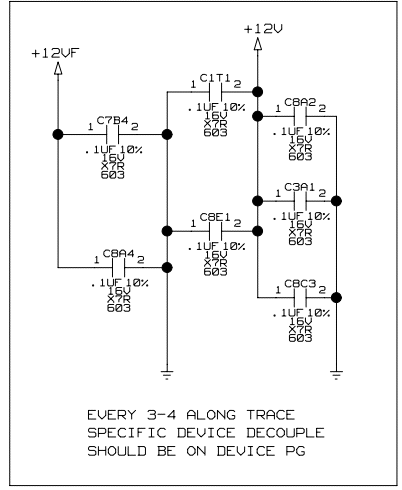

[PAGE\_TITLE=BULK DECOUPLING]

DRAWING  
DVTFABP\_SCH\_11:33  
Fri May 03 11:23:56 2002

INTEL CONFIDENTIAL	DOCUMENT NUMBER XXXXXX	PAGE 33	REV 12.0
-----------------------	---------------------------	------------	-------------

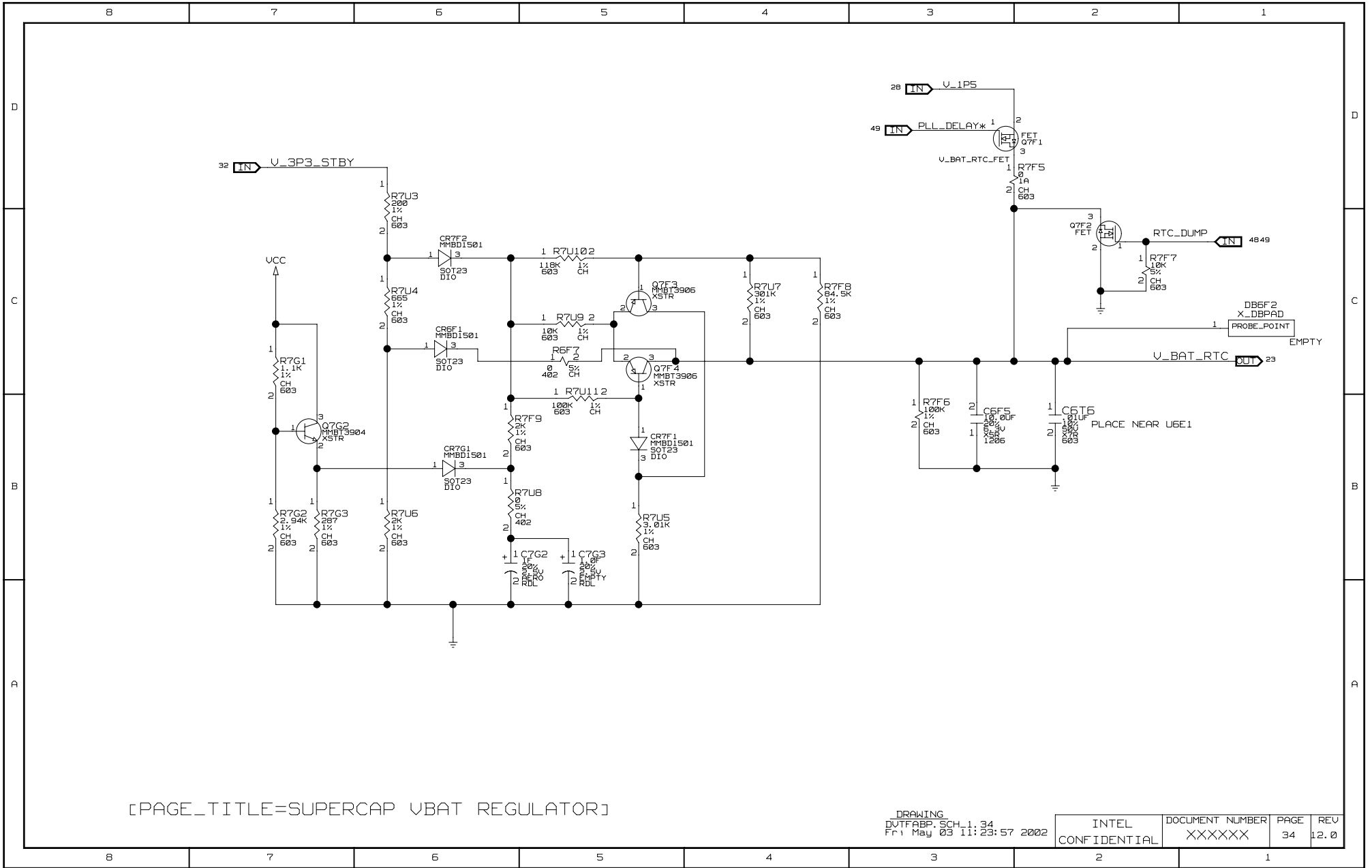

ICS  
ICS1893

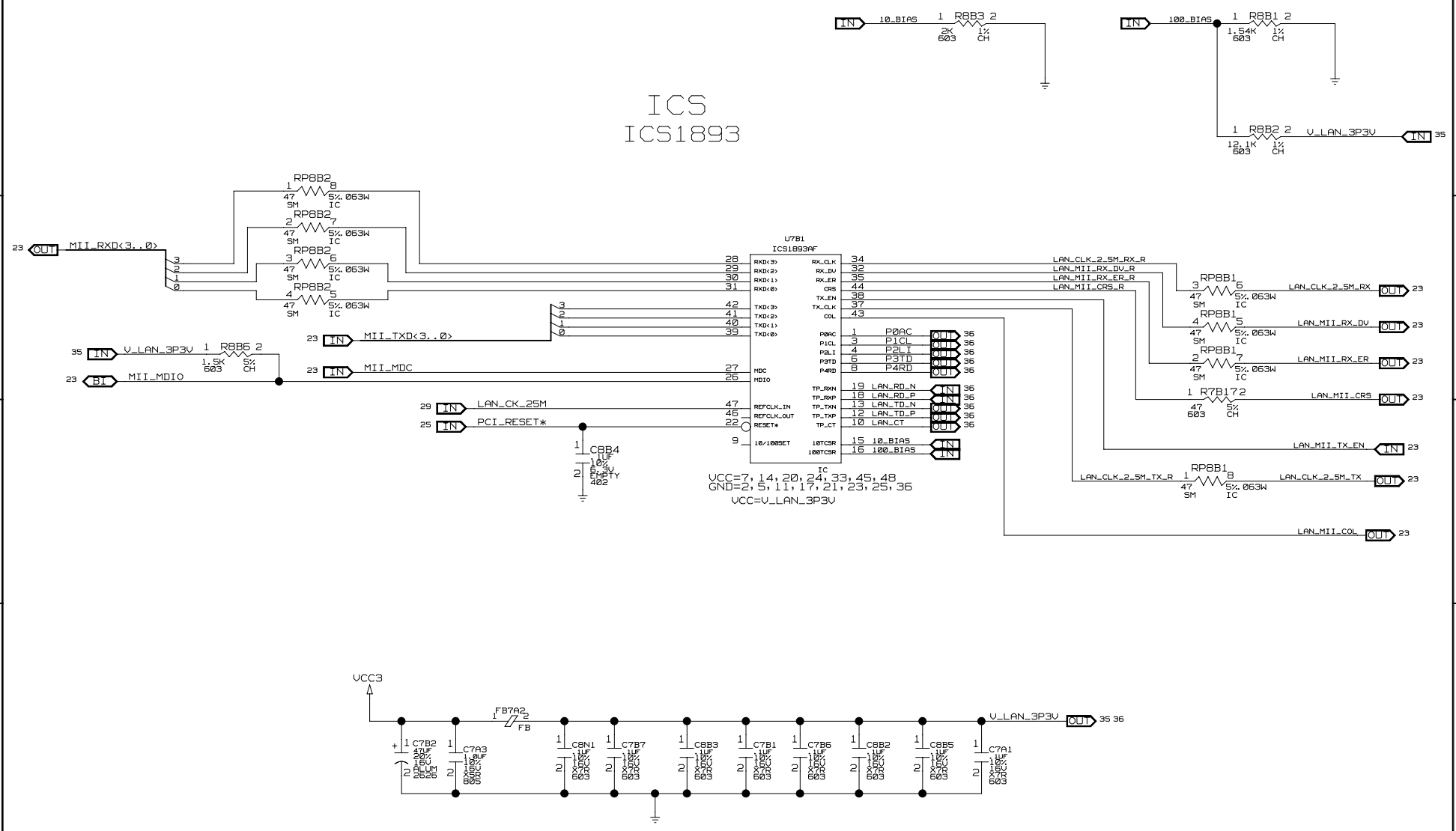

UCC=7, 14, 20, 24, 33, 45, 48  
GND=2, 5, 11, 17, 21, 23, 25, 36  
UCC=V\_LAN\_3P3V

# RJ45 SP JACK

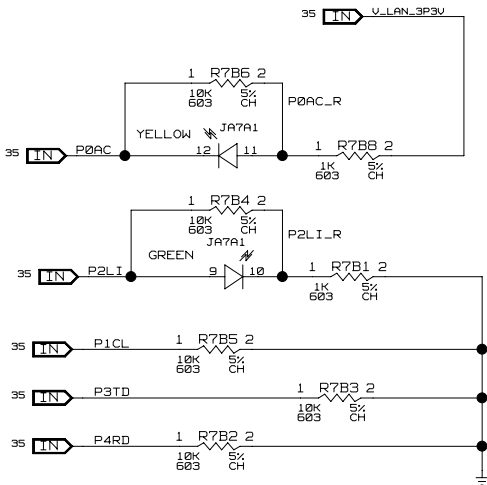
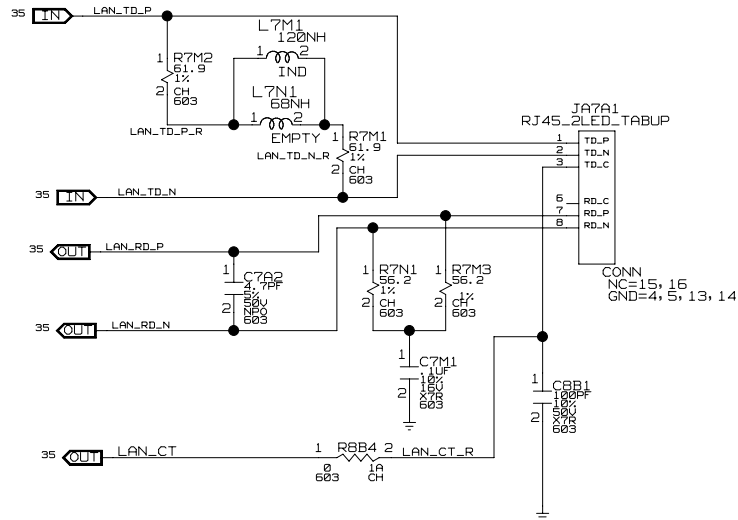

[PAGE\_TITLE=LAN JACK/THERMAL SENSE/EEPROM]

# SERIAL EEPROM 2K BIT

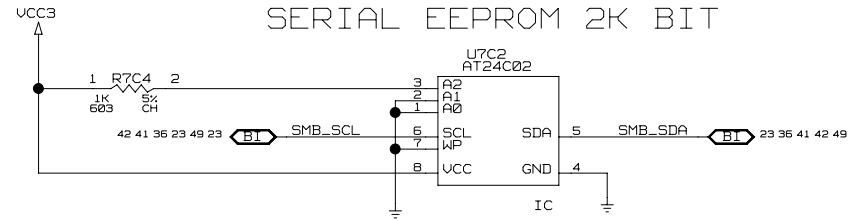

# THERMAL SENSOR

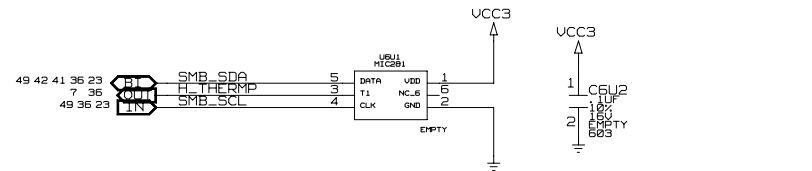
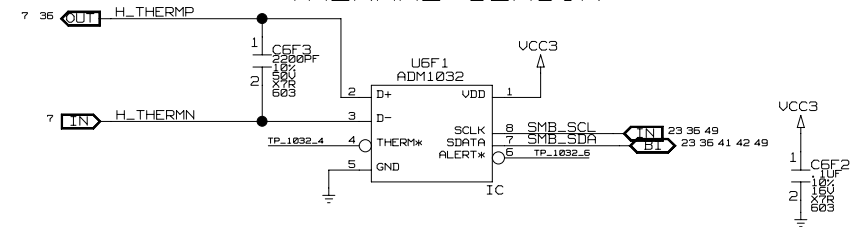

CAD NOTE:  
CONNECT THE GND  
ON CF101 TO PIN 2  
OF U5F100, BEFORE  
VIA TO GND

DRAWING  
DUTFARP\_SCH 1:36  
Fri May 03 11:23:58 2002

INTEL CONFIDENTIAL	DOCUMENT NUMBER XXXXXX	PAGE 36	REV 12.0
-----------------------	---------------------------	------------	-------------

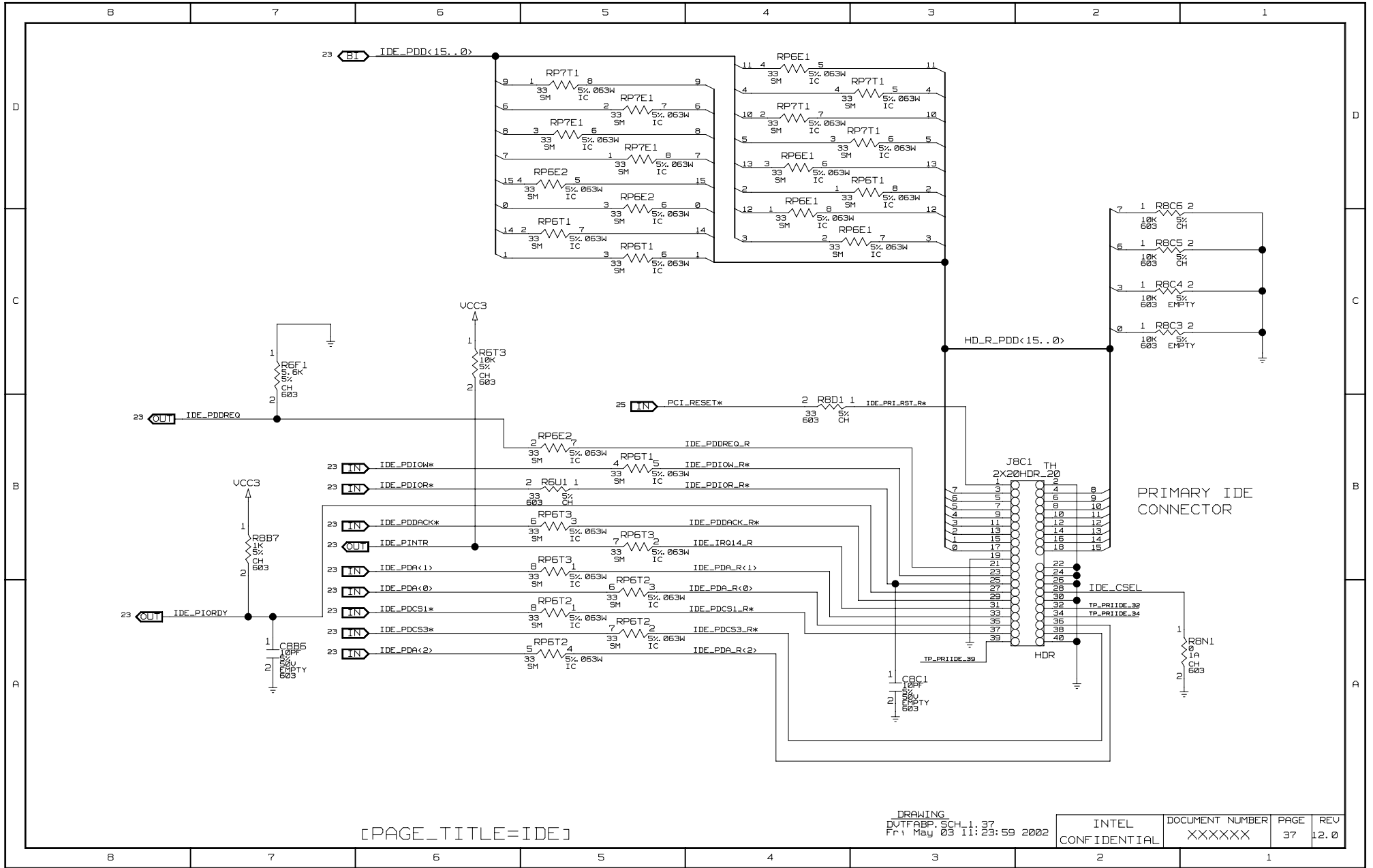

[PAGE\_TITLE=IDE]

DRAWING  
 DVTFABP\_SCH 1:37  
 Fri May 03 11:23:59 2002

INTEL	DOCUMENT NUMBER	PAGE	REV
CONFIDENTIAL	XXXXXX	37	12.0

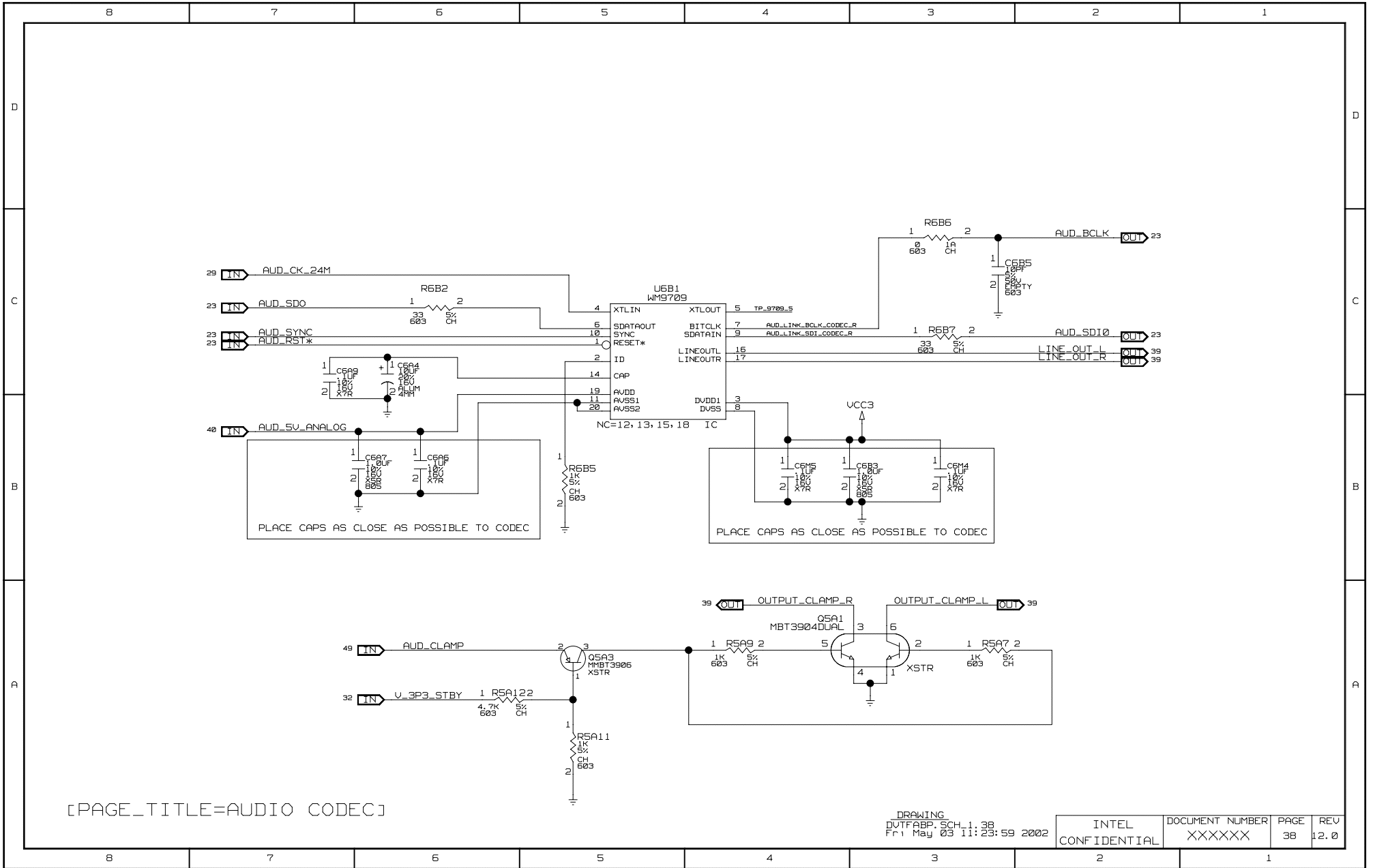

[PAGE\_TITLE=AUDIO CODEC]

DRAWING  
 DUTFABP\_SCH\_11:38  
 Fri May 03 11:23:59 2002

INTEL	DOCUMENT NUMBER	PAGE	REV
CONFIDENTIAL	XXXXXX	38	12.0

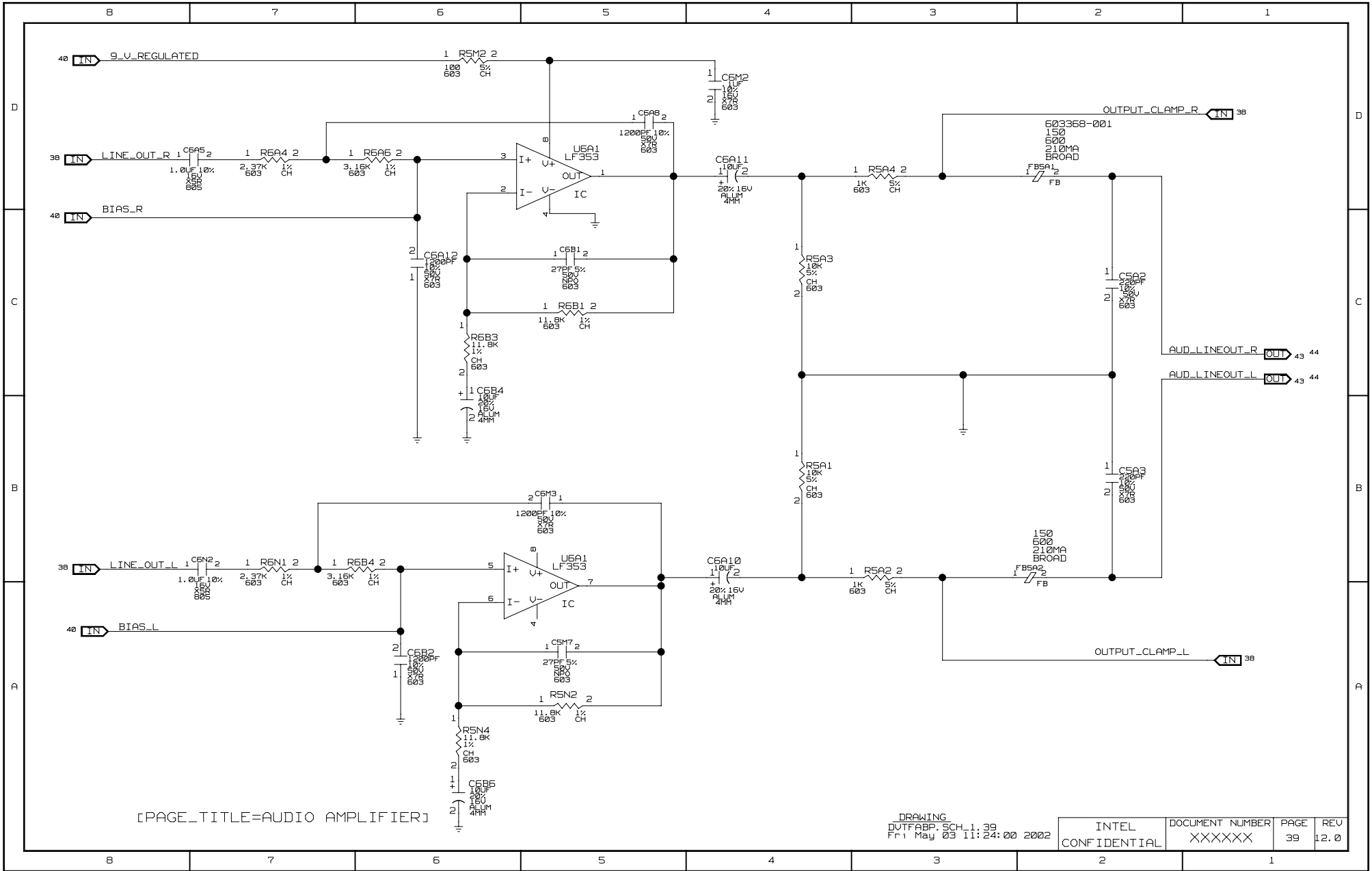

[PAGE\_TITLE=AUDIO AMPLIFIER]

DRAWING  
 DUTFABP\_SCH 1 39  
 Fri May 03 11:24:00 2002

INTEL CONFIDENTIAL	DOCUMENT NUMBER XXXXXX	PAGE 39	REV 12.0
-----------------------	---------------------------	------------	-------------

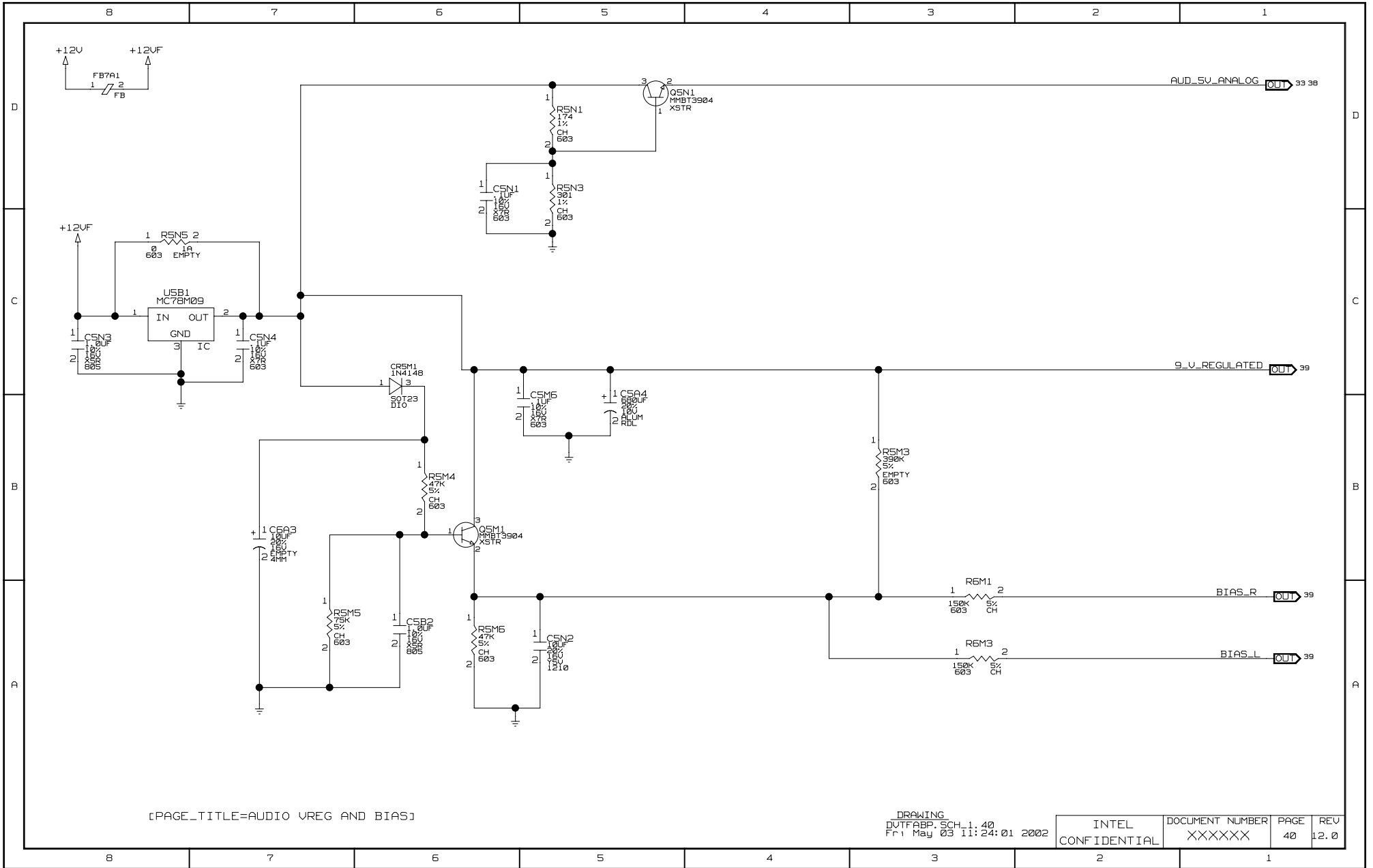

[PAGE\_TITLE=AUDIO VREG AND BIAS]

DRAWING  
 DUTFABP\_SCH\_11:40  
 Fri May 03 11:24:01 2002

INTEL CONFIDENTIAL	DOCUMENT NUMBER XXXXXX	PAGE 40	REV 12.0
-----------------------	---------------------------	------------	-------------



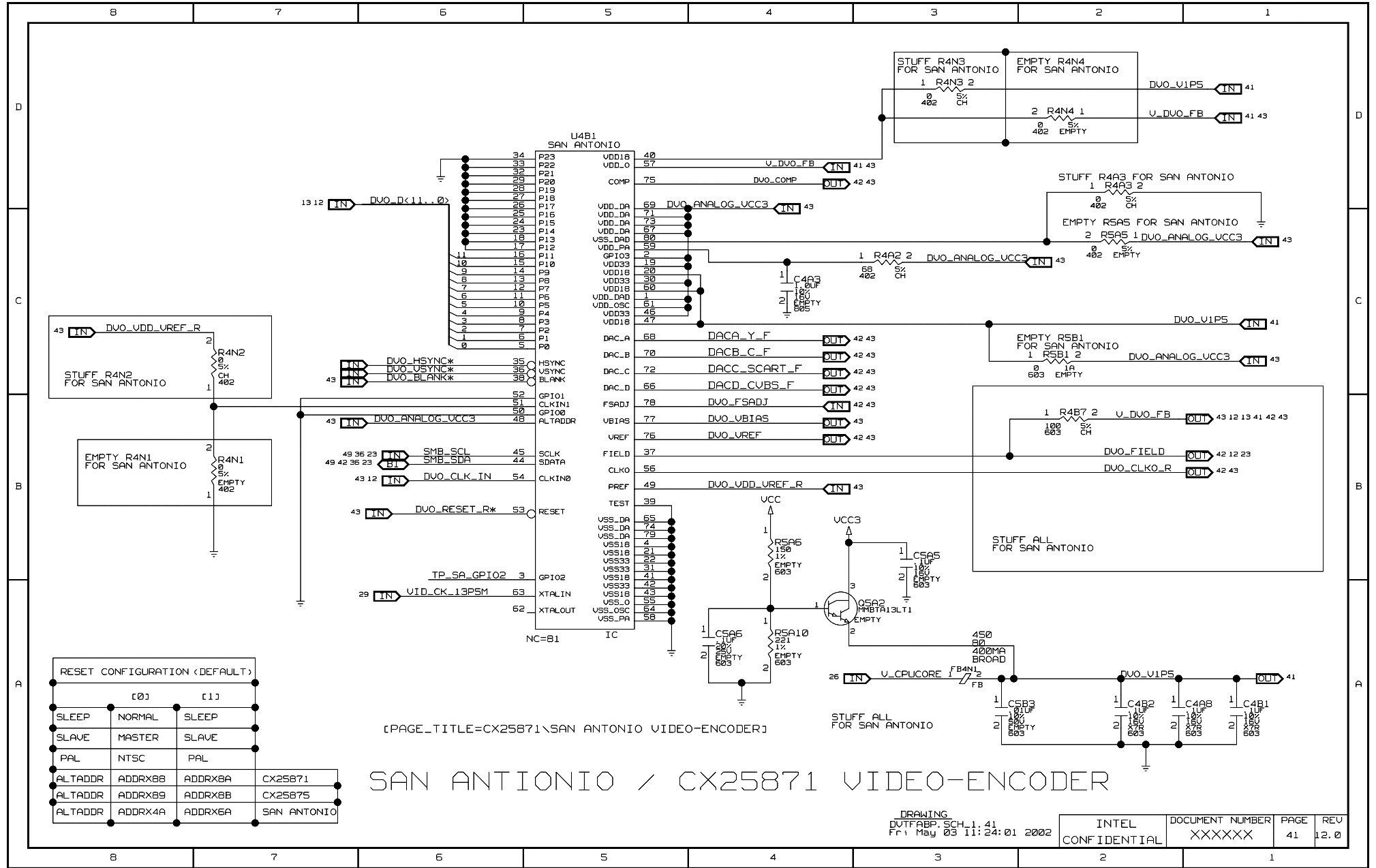

RESET CONFIGURATION (DEFAULT)

	[0]	[1]	
SLEEP	NORMAL	SLEEP	
SLAVE	MASTER	SLAVE	
PAL	NTSC	PAL	
ALTADDR	ADDRX8B	ADDRX8A	CX25871
ALTADDR	ADDRX89	ADDRX8B	CX25875
ALTADDR	ADDRX4A	ADDRX6A	SAN ANTONIO

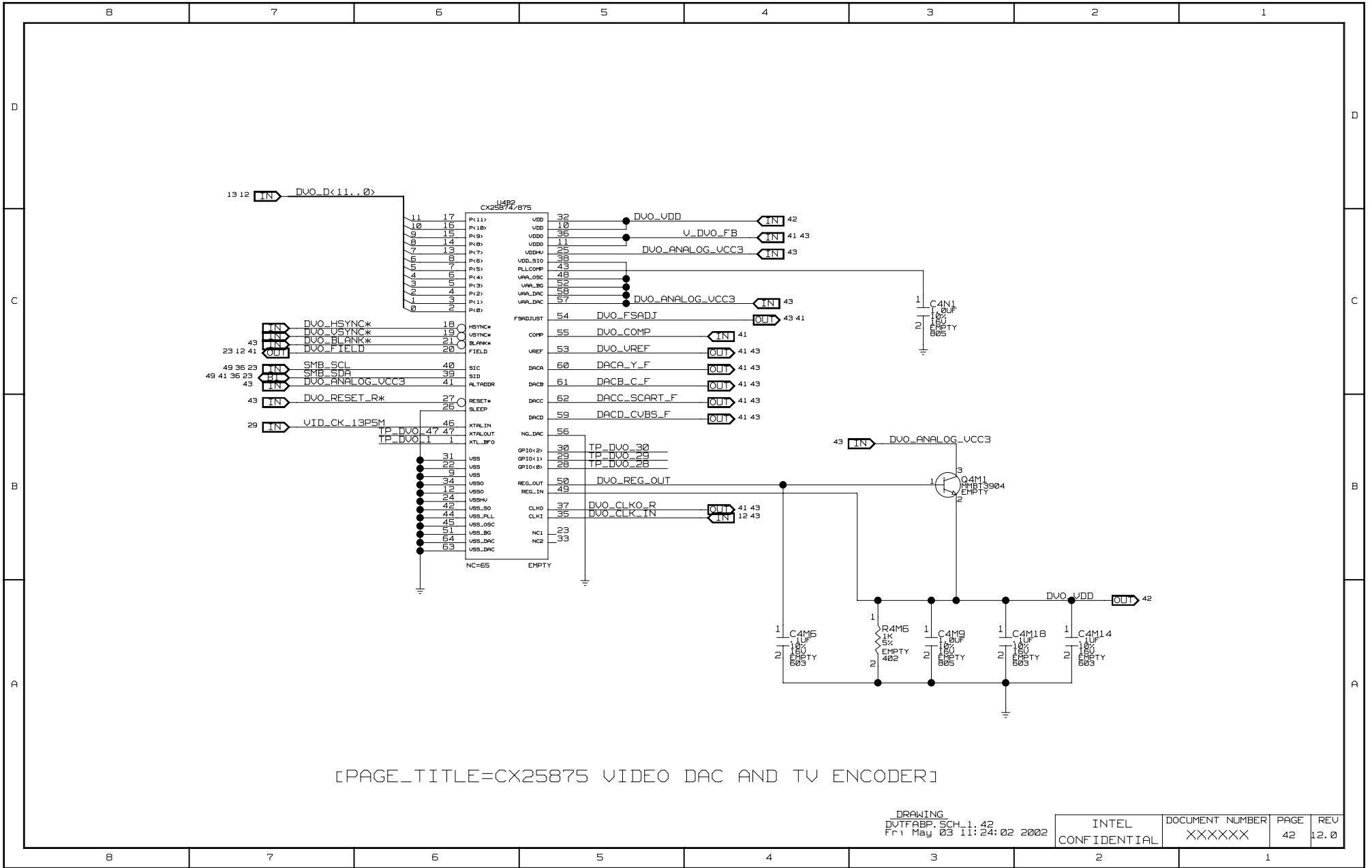

[PAGE\_TITLE=CX25875 VIDEO DAC AND TV ENCODER]

DRAWING  
 DVTFABP\_SCH\_11:42  
 Fri May 03 11:24:02 2002

INTEL CONFIDENTIAL	DOCUMENT NUMBER XXXXXX	PAGE 42	REV 12.0
-----------------------	---------------------------	------------	-------------

DAC	TVOUT	SCART	HDTV
A	Y(LUMA)	G	Y
B	C(CHROMA)	R	PR
C	N/A	B	PB
D	CVBS( COMP)	COMP	N/A

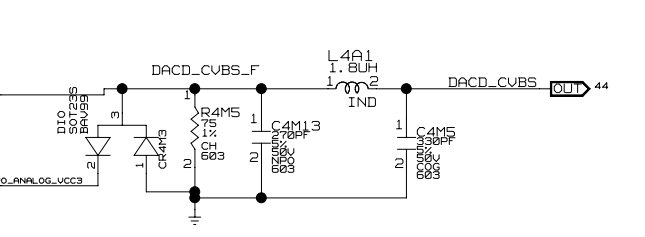
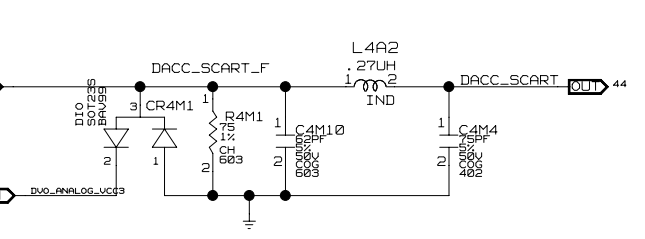
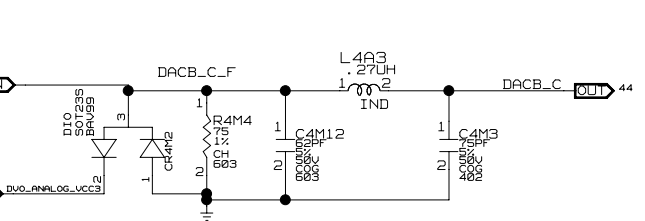
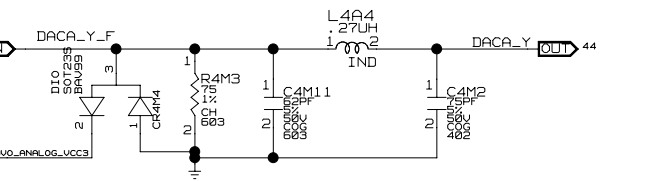
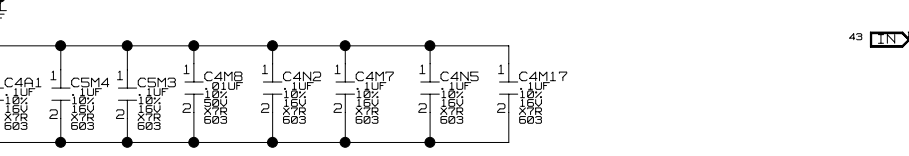
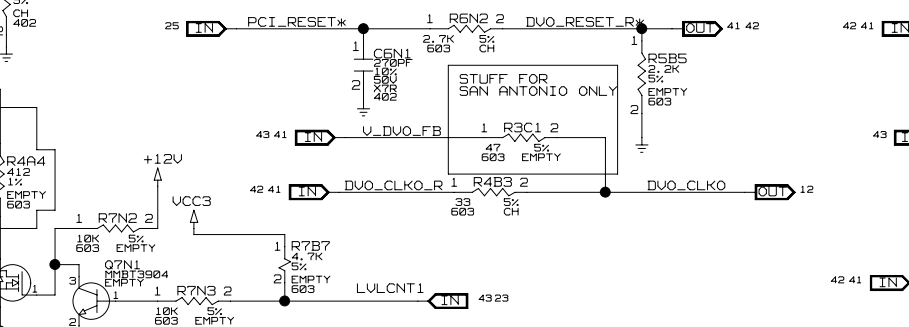
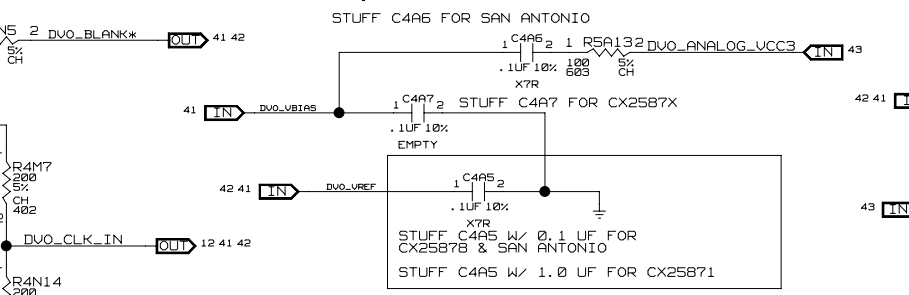
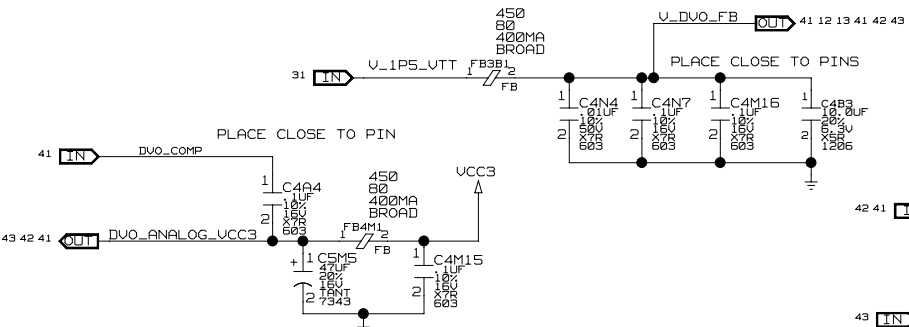

[PAGE\_TITLE=VIDEO DAC AND TV ENCODER]

DRAWING  
DVTFABP\_SCH\_11\_43  
Fri May 03 11:24:03 2002

INTEL	DOCUMENT NUMBER	PAGE	REV
CONFIDENTIAL	XXXXXX	43	12.0

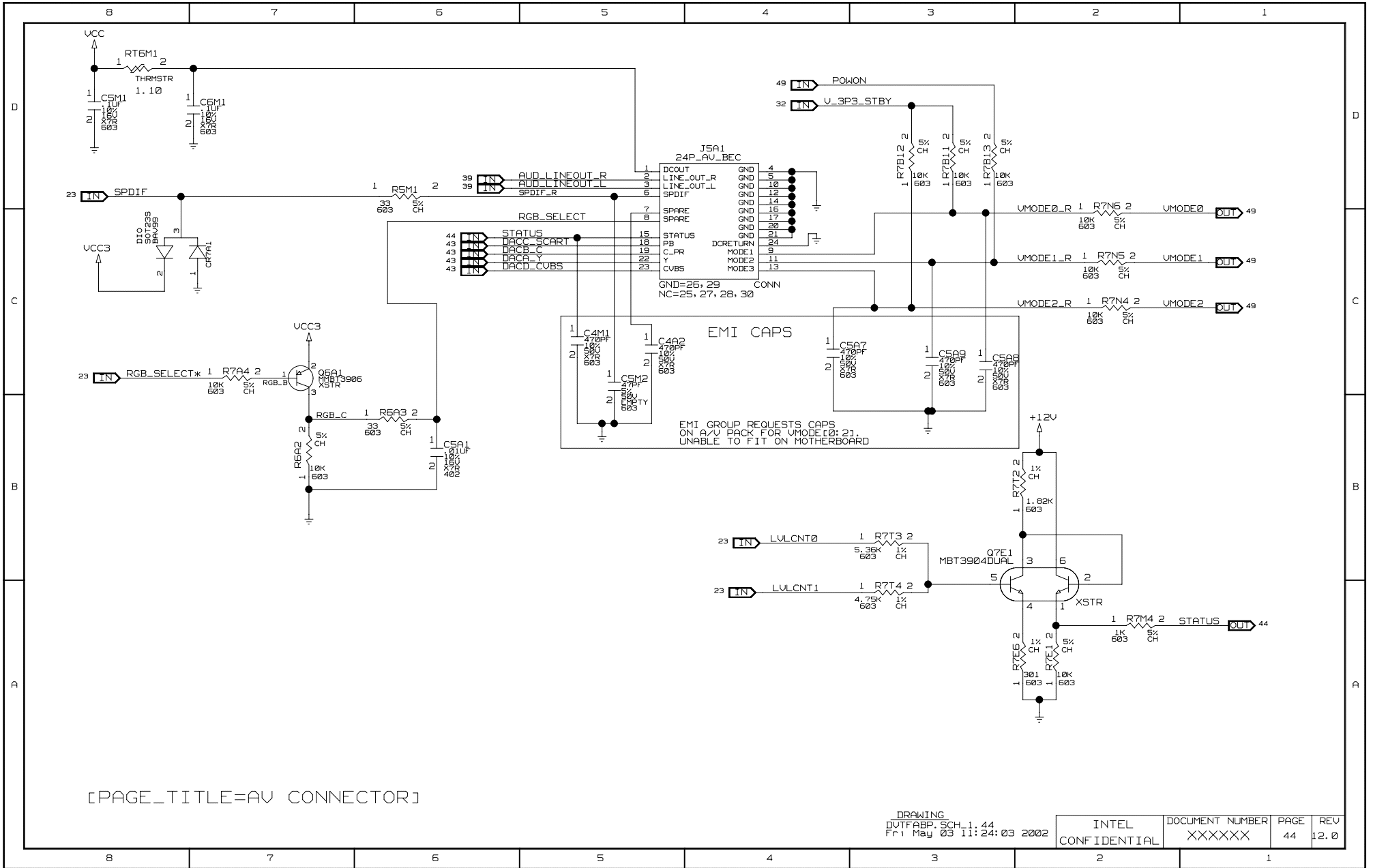

8 7 6 5 4 3 2 1

# LABELS

A19177-001  
LB8D1  
LABEL



1375X250\_TARGET

INTEL INTELLIGENT SERIAL NUMBER TARGET.

D

D

C

C

B

B

A

A

# MOUNTING HOLES

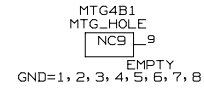
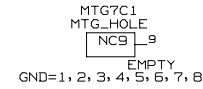
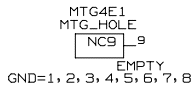
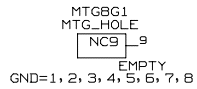
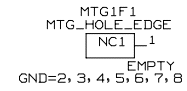
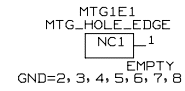
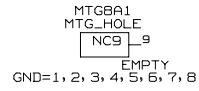
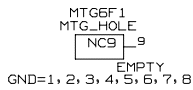
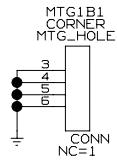

[PAGE\_TITLE=LABELS AND MOUNTING HOLES]

DRAWING  
DUTFABP\_SCH\_1\_45  
Fri May 03 11:24:04 2002

INTEL CONFIDENTIAL	DOCUMENT NUMBER XXXXXX	PAGE 45	REV 12.0
-----------------------	---------------------------	------------	-------------

8 7 6 5 4 3 2 1

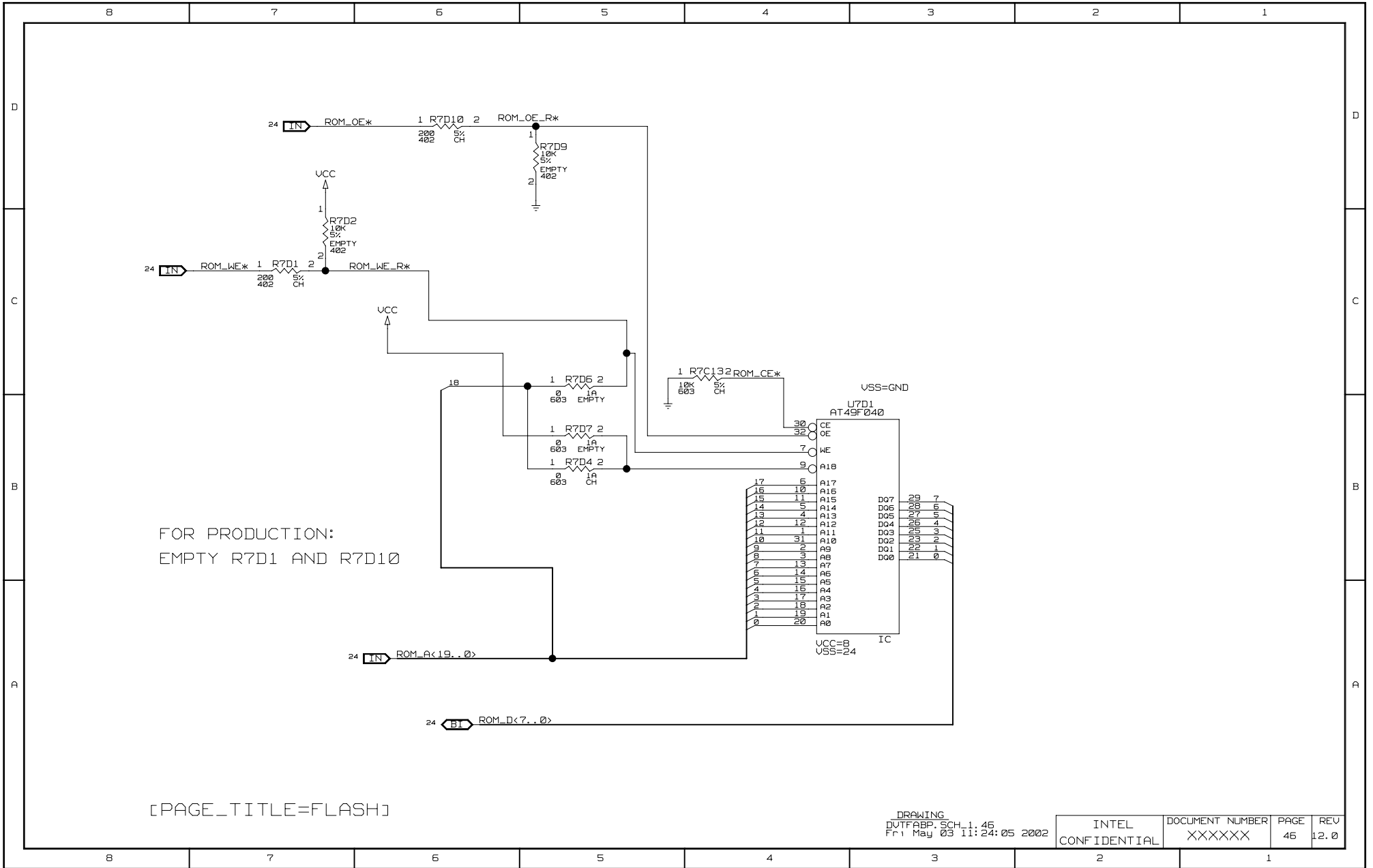

DRAWING  
DVTFABP\_SCH\_1\_46  
Fr 1 May 03 11:24:05 2002

INTEL CONFIDENTIAL	DOCUMENT NUMBER XXXXXX	PAGE 46	REV 12.0
-----------------------	---------------------------	------------	-------------

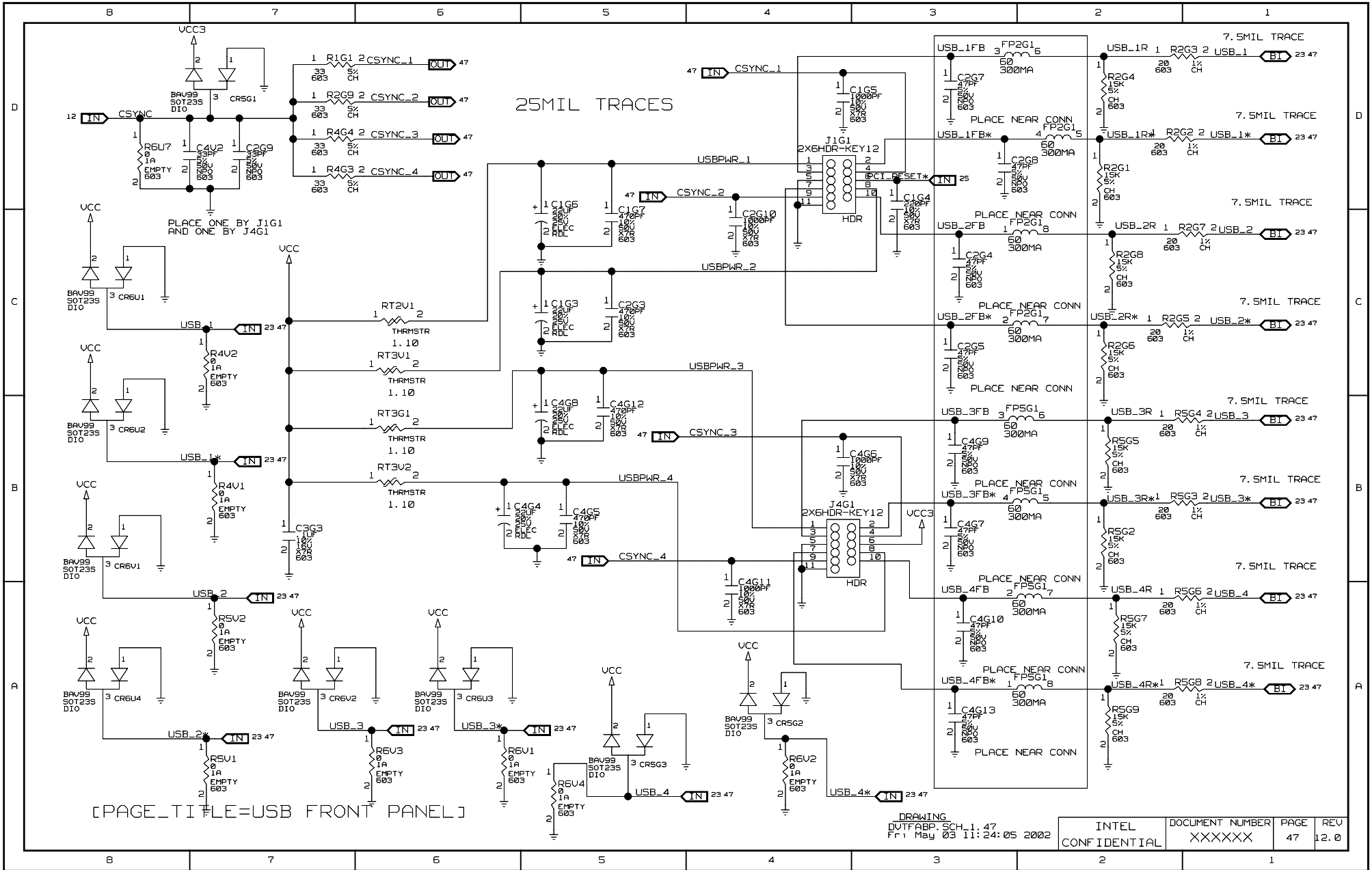

[PAGE\_TITLE=USB FRONT PANEL]

DRAWING  
DUTFABP\_SCH 1: 47  
Fr: May 03 11:24:05 2002

INTEL	DOCUMENT NUMBER	PAGE	REV
CONFIDENTIAL	XXXXXX	47	12.0

5V DRAIN

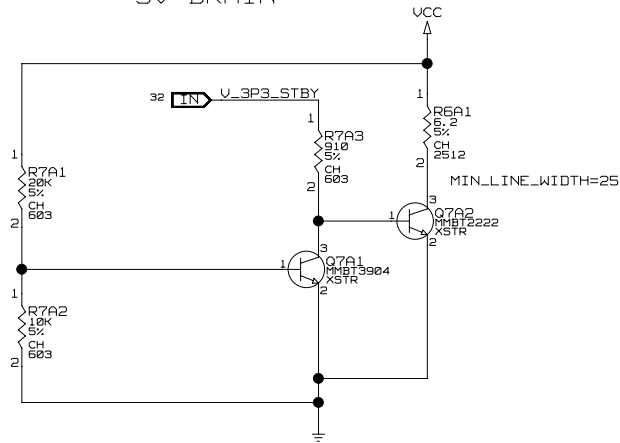

NV2A FAN HEADER

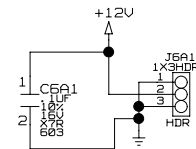

SMC BROWN OUT

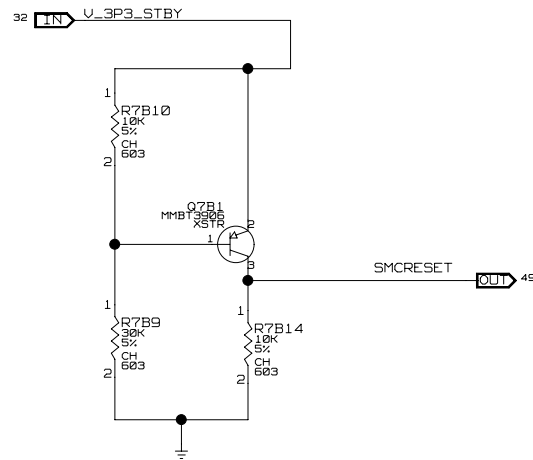

[PAGE\_TITLE=NV2A FAN/5V DRAIN/BROWN OUT]

DRAWING  
DVT/FABP\_SCH 11:24:06 2002  
Fri May 03 11:24:06 2002

INTEL CONFIDENTIAL	DOCUMENT NUMBER XXXXXX	PAGE 48	REV 12.0
-----------------------	---------------------------	------------	-------------



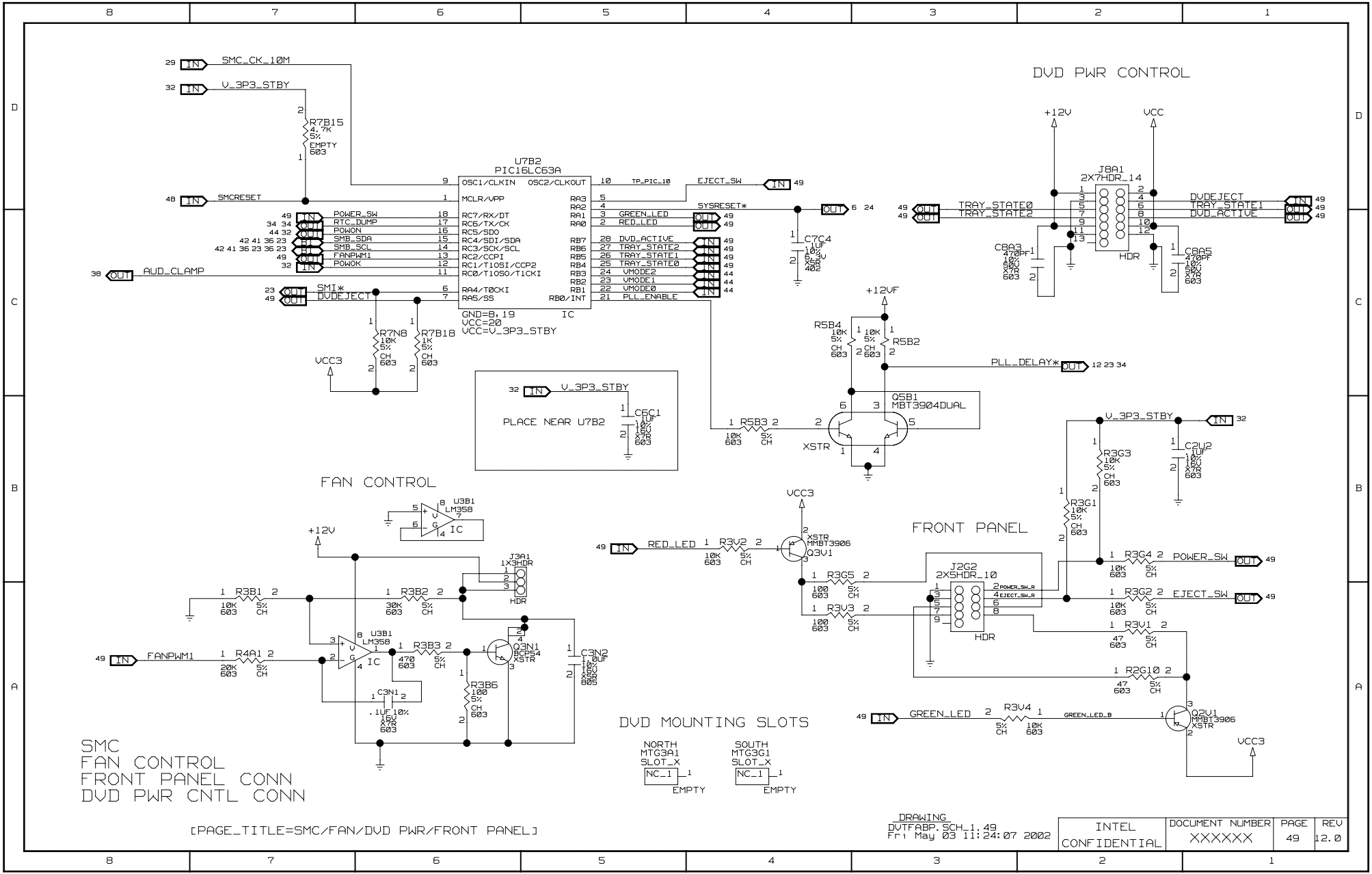

SMC  
FAN CONTROL  
FRONT PANEL CONN  
DVD PWR CNTL CONN

[PAGE\_TITLE=SMC/FAN/DVD PWR/Front Panel]

DVD MOUNTING SLOTS  
NORTH MTG3A1 SLOT\_X  
SOUTH MTG3G1 SLOT\_X  
[NC\_I]\_1 EMPTY

DRAWING  
DVTFABP\_SCH.1:49  
Fri May 03 11:24:07 2002

INTEL CONFIDENTIAL	DOCUMENT NUMBER XXXXXX	PAGE 49	REV 12.0
-----------------------	---------------------------	------------	-------------

# MCPX MUXED PIN ASSIGNMENT

BALL LOCATION	MCP-1 SIGNAL NAME	MCPX SIGNAL NAME	BALL LOCATION	MCP-1 SIGNAL NAME	MCPX SIGNAL NAME
A5	IDE_ADDR_S0	TRST0	Y20	PCI_AD0	XBUS_A23
E6	IDE_ADDR_S1	RESERVED	Y19	PCI_AD1	XBUS_A22
B5	IDE_ADDR_S2	TRST1	AA19	PCI_AD2	XBUS_A21
C5	IDE_CS1_S*	RESERVED	AB17	PCI_AD3	XBUS_A20
B4	IDE_CS3_S*	RESERVED	AA17	PCI_AD4	XBUS_OE*
A6	IDE_DACK_S*	TDI0	Y17	PCI_AD5	XBUS_WE*
B8	IDE_DATA_S0	TD01	V17	PCI_AD6	RESERVED
C8	IDE_DATA_S1	RESERVED	AA16	PCI_AD7	XBUS_D07
D8	IDE_DATA_S2	RESERVED	V16	PCI_AD8	XBUS_A19
B9	IDE_DATA_S3	TCK1	AB15	PCI_AD9	XBUS_A14
D9	IDE_DATA_S4	RESERVED	AA15	PCI_AD10	XBUS_A15
B10	IDE_DATA_S5	TMS1	Y15	PCI_AD11	XBUS_D06
E10	IDE_DATA_S6	RESERVED	W15	PCI_AD12	XBUS_A16
B11	IDE_DATA_S7	TDE1*	V15	PCI_AD13	XBUS_A17
A11	IDE_DATA_S8	TDE0*	AB14	PCI_AD14	XBUS_D04
E11	IDE_DATA_S9	RESERVED	AA14	PCI_AD15	XBUS_A13
C10	IDE_DATA_S10	RESERVED	Y11	PCI_AD16	XBUS_D03
E9	IDE_DATA_S11	RESERVED	W11	PCI_AD17	XBUS_CE*
A9	IDE_DATA_S12	TMS0	V11	PCI_AD18	XBUS_A12
C9	IDE_DATA_S13	RESERVED	AA10	PCI_AD19	XBUS_A9
E8	IDE_DATA_S14	RESERVED	Y10	PCI_AD20	XBUS_D02
A8	IDE_DATA_S15	TCK0	V10	PCI_AD21	XBUS_A10
E7	IDE_DRQ_S	RESERVED	AB9	PCI_AD22	XBUS_A6
B6	IDE_INTR_S	TDI1	AA9	PCI_AD23	XBUS_D00
B7	IDE_IOR_S*	TD00	W9	PCI_AD24	XBUS_D01
C7	IDE_IOW_S*	RESERVED	V9	PCI_AD25	XBUS_A8
C6	IDE_RDY_S	RESERVED	AA8	PCI_AD26	XBUS_A3
			Y8	PCI_AD27	XBUS_A4
			W8	PCI_AD28	XBUS_A0
Y21	PCI_GNT0*	RESERVED	V8	PCI_AD29	XBUS_A5
Y18	PCI_GNT1*	RESERVED	V7	PCI_AD30	XBUS_A2
AA13	PCI_GNT2*	RESERVED	V6	PCI_AD31	XBUS_A1

BALL LOCATION	MCP-1 SIGNAL NAME	MCPX SIGNAL NAME	BALL LOCATION	MCP-1 SIGNAL NAME	MCPX SIGNAL NAME
Y7	PCI_GNT3*	RESERVED	Y16	PCI_CBE0*	XBUS_A18
Y6	PCI_GNT4*	RESERVED	W14	PCI_CBE1*	XBUS_D05
V12	PCI_IRDY*	RESERVED	AA11	PCI_CBE2*	XBUS_A11
Y14	PCI_PAR	RESERVED	Y9	PCI_CBE3*	XBUS_A7
Y13	PCI_PERR*	RESERVED	Y12	PCI_DEUSEL*	RESERVED
AA20	PCI_REQ0*	RESERVED	AB11	PCI_FRAME*	RESERVED
AA18	PCI_REQ1*	RESERVED	V14	PCI_SERR*	RESERVED
AA12	PCI_REQ2*	RESERVED	V13	PCI_STOP*	RESERVED
AA7	PCI_REQ3*	RESERVED	W12	PCI_TRDY*	RESERVED
AA6	PCI_REQ4*	RESERVED			

## VOLTAGE RAILS

RAIL	TYPICAL (V)	
V_CPUCORE	1.7V (CPU DEPENDENT)	
VCC	5V	
VCC3	3.3V	
V_3P3_STBY	3.3V STANDBY	
V_2P5	2.65V	
V_1P5	1.65V	
V_1P5_VTT	1.5V	
V_1P25_MEMVTT	1.325V	

[PAGE\_TITLE=MCPX MUXED PIN ASSIGNMENT]

DRAWING  
DVTFABP\_SCH\_1\_50  
Fri May 03 11:24:07 2002

INTEL CONFIDENTIAL	DOCUMENT NUMBER XXXXXX	PAGE 50	REV 12.0
-----------------------	---------------------------	------------	-------------

D

D

C

C

B

B

A

A

\*\*\* Signal Cross-Reference \*\*\*  
 --- for the entire design ---

9\_V\_REGULATED 40C1 39D8  
 10\_BIAS 35B3 35D4  
 100\_BIAS 35B3 35D2  
 AUD\_SV\_ANALOG 40D1 33B4 3BB7  
 AUD\_BCLK 38C2 23C8  
 AUD\_BCLK\_R 23C7  
 AUD\_CK\_24M 29D2 38C7  
 AUD\_CK\_24M\_R 29D5  
 AUD\_CLAMP 49C8 39A6  
 AUD\_LINEOUT\_L 39C1 44D6  
 AUD\_LINEOUT\_R 39C1 44D6  
 AUD\_LINK\_BCLK\_CODEC\_R 38C4  
 AUD\_LINK\_SDI\_CODEC\_R 38C4  
 AUD\_RST\* 23C7 38C7  
 AUD\_SDI0 38C2 23C7  
 AUD\_SDO 23C8 38C7  
 AUD\_SYNC 23C7 38C7  
 BGA2\_BRE00\_C6 6B4  
 BIAS\_L 40A1 39A8  
 BIAS\_R 40A1 39C8  
 CK\_H\_133M\_CPU 11B5 6A7  
 CK\_H\_133M\_CPU\_BUF 6B5 6B8  
 CK\_H\_133M\_CPU\_R 6B5  
 CK\_H\_133M\_FB 11B6  
 CK\_H\_133M\_FB\_R 11B6  
 CK\_H\_PICCLK 11B6  
 CK\_H\_PICCLK\_R 11B4 6B5  
 CLK\_XTAL\_X1 29D7  
 CLK\_XTAL\_X2 29D7  
 CNFG\_SEL0 25C7 23C4  
 CNFG\_SEL1 25C7 23B4  
 CNFG\_SEL2 25C7 23C4  
 CSYNC 12B2 47D8  
 CSYNC\_1 47D6 47D4  
 CSYNC\_2 47D6 47D5  
 CSYNC\_3 47D6 47B5  
 CSYNC\_4 47D6 47B5  
 DAC\_A\_Y 43D1 44C6  
 DAC\_A\_Y\_F 41C4 42C4 43D3  
 DAC\_B\_C 43C1 44C6  
 DAC\_B\_C\_F 41C4 42C4 43C3  
 DAC\_SCART 43B1 44C6  
 DAC\_SCART\_F 41C4 42B4 43B3  
 DACD\_CUBS 43A1 44C6  
 DACD\_CUBS\_F 41C4 42B4 43A3  
 DUDEJECT 49C7 49D1  
 DUDEACTIVE 49C1 49C4  
 DVO\_ANALOG\_VCC3 43D7 41B6 41C1 41C2 41C4 42B3 42C4  
 42C7 43A3 43A8 43B3 43C3 43C4  
 DVO\_BLANK\* 43C5 41C6 42C7  
 DVO\_CLK0 43A4 12C2  
 DVO\_CLK0\_R 41B2 42B4 43A6  
 DVO\_CLK\_IN 12C2 43B6 41B6 42B4  
 DVO\_COMP 41D4 42C4 43D7  
 DVO\_D(11..0) 12C2 13D7 41D6 42D7  
 DVO\_FIELD 41B2 42C7 12C2 23C2  
 DVO\_FIELD\_3P3\* 23B5  
 DVO\_FSADJ 42C4 43B8 41B4  
 DVO\_HSYNC\* 12C2 41C6 42C7  
 DVO\_REG\_OUT 42B5  
 DVO\_RESET\_R\* 43B4 41B6 42B7  
 DVO\_VIPS 41A1 41C1 41D1  
 DVO\_VBIAS 41B4 43C6  
 DVO\_VDD 42A2 42C4  
 DVO\_VDD\_VREF\_R 43B8 41B4 41C8  
 DVO\_VREF 41B4 42C4 43C6  
 DVO\_VSYNC\* 12C2 41C6 42C7

EJECT\_SW 49A1 49D4  
 EJECT\_SW\_R 49A3  
 FANPM1 49C7 49A8  
 GREEN\_LED 49C4 49A3  
 GREEN\_LED\_B 49A2  
 HD\_R\_PDD(15..0) 37C3  
 H\_LA\*(31..3) 5D3 11D5  
 H\_LA20M\* 24D5 5B3  
 H\_LA20M\_R\* 5B5  
 H\_LADS\* 6C2 11C6  
 H\_LBNR\* 6B5 11C6  
 H\_LBPRI\* 11C6 6B5  
 H\_LCPU\_RST\* 11C5 24D5  
 H\_LCPU\_RST\_R\* 11C4 6C7  
 H\_LD\*(63..0) 5D7 11D8  
 H\_LDBSY\* 6B2 11C6  
 H\_DEFER\* 11C6 6B2  
 H\_DRDY\* 6B2 11C6  
 H\_FERR\* 5B3 24D5  
 H\_HIT\* 6C2 11C6  
 H\_HITM\* 6B2 11B6  
 H\_IGNNE\* 24D5 5B3  
 H\_INIT\* 6C5  
 H\_INTR 24A6 6B7  
 H\_INTR\_R 6B5  
 H\_LOCK\* 6B5 11B6  
 H\_LNMI 24D5 6B7  
 H\_LNMI\_R 6B5  
 H\_LPREQ\* 10B2 5B4  
 H\_LREQ\*(4..0) 6B5 11A8  
 H\_LRS\*(2..0) 11B5 6B2  
 H\_LSMI\* 6A1 6B6  
 H\_LSMI\_R\* 24D5 6A3  
 H\_LTC 10B7 5B4  
 H\_TDI 10B2 5B4  
 H\_THERM1 7C7 36A3 36C4  
 H\_THERM2 36B3 36C4 7C7  
 H\_TMS 10B7 5B4  
 H\_TRDY\* 11B6 6B2  
 H\_TRST\* 10B2 5B4  
 H\_VID\_0 26B8  
 H\_VID\_1 26B8  
 H\_VID\_2 26B8  
 H\_VID\_3 26B8  
 ICS\_S0 29A6 29D7  
 ICS\_S1 29A6 29D7  
 ICS\_SEL 29A6 29D7  
 IDE\_CSEL 37A2  
 IDE\_LIRQ14\_R 37B4  
 IDE\_PDA\*(2..0) 23D4 37A6 37B6  
 IDE\_PDA\_R(2..0) 37A4 37B4  
 IDE\_PDCS1\* 23D4 37A6  
 IDE\_PDCS1\_R\* 37A4  
 IDE\_PDCS3\* 23D4 37A6  
 IDE\_PDCS3\_R\* 37A4  
 IDE\_PDD(15..0) 23D4 37D6  
 IDE\_PDDACK\* 23D4 37B6  
 IDE\_PDDACK\_R\* 37B4  
 IDE\_PDDREQ 37B8 23D4  
 IDE\_PDDREQ\_R 37B5  
 IDE\_PD1OR\* 23D4 37B6  
 IDE\_PD1OR\_R\* 37B5  
 IDE\_PD1OW\* 23D4 37B6  
 IDE\_PD1OW\_R\* 37B5  
 IDE\_PINTR 37B6 23D4  
 IDE\_PIORDY 37A8 23D4  
 IDE\_PRI\_RST\_R\* 37B3  
 KBRSTIN\* 24C5  
 LAN\_CK\_25M 29D2 35B6  
 LAN\_CK\_25M\_R 29D6

LAN\_CLK\_2\_5M\_RX 35C1 23B7  
 LAN\_CLK\_2\_5M\_RX\_R 35C3  
 LAN\_CLK\_2\_5M\_TX 35B1 23B7  
 LAN\_CLK\_2\_5M\_TX\_R 35B3  
 LAN\_CT 35B3 36B8  
 LAN\_CT\_R 36B7  
 LAN\_MII\_COL 35B1 23B7  
 LAN\_MII\_CRS 35C1 23B7  
 LAN\_MII\_CRS\_R 35C3  
 LAN\_MII\_RX\_DV 35C1 23B7  
 LAN\_MII\_RX\_DV\_R 35C3  
 LAN\_MII\_RX\_ER 35C1 23B7  
 LAN\_MII\_RX\_ER\_R 35C3  
 LAN\_MII\_TX\_EN 23B7 35B1  
 LAN\_RD\_N 36C8 35C3  
 LAN\_RD\_P 36C8 35C3  
 LAN\_TD\_N 35B3 36C8  
 LAN\_TD\_N\_R 36D7  
 LAN\_TD\_P 35B3 36D8  
 LAN\_TD\_P\_R 36D8  
 LDT\_RESET\* 12A4 24A5  
 LDT\_RXD\*(8..0) 24A5 12B5  
 LDT\_RXD\*(B..0) 24A8 12C4  
 LDT\_RX\_CK 24A7 12B2  
 LDT\_RX\_CK\* 24A5 12B2  
 LDT\_TXD\*(8..0) 12B4 24B5  
 LDT\_TXD\*(B..0) 12C4 24B8  
 LDT\_TX\_CK 12B2 24A7  
 LDT\_TX\_CK\* 12B2 24A5  
 LINE\_OUT\_L 38C2 39B8  
 LINE\_OUT\_R 38C2 39D8  
 LVL\_CNT0 23C4 44B4  
 LVL\_CNT1 23C4 43A5 44A4  
 L\_AD(3..0) 23D7 23A4 25C5  
 L\_FRAME\* 23D7 23A3  
 L\_SERI0 23A2 23D8  
 MCPX\_TCK0 24C5 25B5  
 MCPX\_TCK1 24C5 25B5  
 MCPX\_TDE0 24C5 25C5  
 MCPX\_TDE1 24C5 25C5  
 MCPX\_TDI0 24C5 25C5  
 MCPX\_TDI1 24C5 25C5  
 MCPX\_TMS0 24C5 25C5  
 MCPX\_TMS1 24C5 25C5  
 MCPX\_TRST0 24C5 25B5  
 MCPX\_TRST1 24C5 25B5  
 MCP\_3P3\_DELAY 23A7  
 MCP\_VDD\_PLL 23A5 23B4  
 MII\_MDC 23B8 35C7  
 MII\_MDIO 23B7 35C8  
 MII\_RXD(3..0) 35C8 23B7  
 MII\_TXD(3..0) 23B7 23D2 35C7  
 M\_AB\_CKE 14A4 15A4  
 M\_A\_ADDR(13..0) 11D4 14D7  
 M\_A\_CAS\* 11C4 14B2 14B6  
 M\_A\_CLK 11C4 14A4  
 M\_A\_CLK\* 11C2 14A4  
 M\_A\_CS\*(1..0) 11C5 14B2 14B7  
 M\_A\_DATA(31..0) 11D1 14D7 18D4 18D6  
 M\_A\_DQM(3..0) 11D4 18B4 14C2 14C7  
 M\_A\_DOS 11C4 14A4 18C3  
 M\_A\_RAS\* 11C4 14B2 14B6  
 M\_A\_WE\* 11C4 14B2 14B6  
 M\_B\_ADDR(13..0) 11B4 15D7  
 M\_B\_CAS\* 11A3 15B2 15B7  
 M\_B\_CLK 11A3 15A4  
 M\_B\_CLK\* 11A1 15A4  
 M\_B\_CS\*(1..0) 11A5 15B2 15B7  
 M\_B\_DATA(31..0) 11B1 15D7 18C4 18D1  
 M\_B\_DQM(3..0) 11B4 18A4 15C2 15C7

M\_B\_DOS 11A3 15A4 18A3  
 M\_B\_RAS\* 11A3 15B2 15B7  
 M\_B\_WE\* 11A3 15B2 15B7  
 M\_CD\_CKE 16A4 17A4  
 M\_C\_ADDR(13..0) 12D8 16D7  
 M\_C\_CAS\* 12C7 16B2 16B7  
 M\_C\_CLK 12C7 16A4  
 M\_C\_CLK\* 12B5 16A4  
 M\_C\_CS\*(1..0) 12C8 16B2 16B7  
 M\_C\_DATA(31..0) 12D5 16D7 19D4 19D6  
 M\_C\_DQM(3..0) 12C8 19B4 16C2 16C7  
 M\_C\_DOS 12C7 16A4 19B3  
 M\_C\_RAS\* 12C7 16B2 16B7  
 M\_C\_WE\* 12C7 16C2 16C7  
 M\_D\_ADDR(13..0) 12B8 17D7  
 M\_D\_CAS\* 12A7 17B2 17B7  
 M\_D\_CLK 12A7 17A4  
 M\_D\_CLK\* 12A5 17A4  
 M\_D\_CS\*(1..0) 12A8 17B2 17B7  
 M\_D\_DATA(31..0) 12B5 17D7 19C4 19D1  
 M\_D\_DQM(3..0) 12A8 19A4 17C2 17C7  
 M\_D\_DOS 12A7 17A4 19A3  
 M\_D\_RAS\* 12A7 17B2 17B7  
 M\_D\_WE\* 12A7 17B2 17B7  
 M\_VREF\_0 14A3 14B7 15A2 15A7  
 M\_VREF\_1 16A3 16B8 17A2 17A7  
 NB\_CK\_13PSM 29D1 11B5  
 NB\_CK\_13PSM\_R 29D5  
 NV2A\_3P3\_DELAY 12A2  
 NV2A\_INTA\* 12B2 24C4  
 NV2A\_TEST 12B2  
 NV2A\_VREF\_0 11C2  
 NV2A\_VREF\_1 12C6  
 OUTPUT\_CLAMP\_L 39A3 39A1  
 OUTPUT\_CLAMP\_R 39A4 39D1  
 P8AC 35C3 36B8  
 P8AC\_R 36B7  
 P1CL 35C3 36A8  
 P2LI 35C3 36A8  
 P2LI\_R 36A7  
 P3TD 35C3 36A8  
 P4RD 35C3 36A8  
 PCI\_CLK 24C5 23A3  
 PCI\_CLK\_FB 24C6  
 PCI\_FRAME 24A1 25D5  
 PCI\_PULLUP 23A3 24A1  
 PCI\_RESET\* 25A5 12B2 14A7 16A7 23A4 35B6 37B5  
 43B6 47D3  
 PCI\_RESET\_B\* 24C4 25A8  
 PICD0 6B7  
 PICD1 6B8  
 PLLVDD 12A2  
 PLL\_DELAY\* 49C2 12A4 23A8 34D3  
 PLL\_ENABLE 49C5  
 POWER\_S4 49B1 49C7  
 POWER\_S4\_R 49B3  
 POWOK 32C4 29C4 29D7 49C7  
 POWON 49C7 32C6 44D4  
 RED\_LED 49C4 49B5  
 RGB\_B 44C7  
 RGB\_C 44B7  
 RGB\_SELECT 44C6  
 RGB\_SELECT\* 23C4 44C8  
 ROM\_A(19..0) 24D8 46A6  
 ROM\_CE\* 46C4  
 ROM\_D(7..0) 24C8 46A6  
 ROM\_OE\* 24C7 46D7  
 ROM\_OE\_R\* 46D6  
 ROM\_WE\* 24C8 46C7  
 ROM\_WE\_R\* 46C7

	8	7	6	5	4	3	2	1
D								
C								
B								
A								
	8	7	6	5	4	3	2	1

```

RSET_NV2A* 12A4
RTC_DUMP 49C7 34C1
RTC_X1 23B5
RTC_X0 23B5
SB_CK_13P5M 29D2 23B4
SB_CK_13P5M_LR 29D6
SMB_SCL 23B3 36D3 49C7 23A4 36B3 36C2 41B6
42C7
SMB_SDA 23A2 23B3 36B2 36B3 36D1 41B6 42C7
49C7
SMCRESET 4BA3 49D7
SMC_CK_10M 29D2 49D7
SMC_CK_10M_LR 29D5
SM1* 49C7 23C4
SPDIF 23B3 44D8
SPDIF_R 44D6
SPKR_STRAP 23B5
STATUS 44A1 44C6
SYSRESET* 49C4 6B2 24D5
SYSRESET_R* 6B2 6C7
TP16_EN 26B8 26C7
TP_1032_4 36B3
TP_1032_6 36B2
TP_3709_5 36C4
TP_BGA2_24 5C4
TP_BGA2_A5 5C4
TP_BGA2_AA1 6C3
TP_BGA2_AA17 7C7
TP_BGA2_AA21 5B4
TP_BGA2_AB1 6C3
TP_BGA2_AB19 7B7
TP_BGA2_AC17 7B7
TP_BGA2_AD9 5B4
TP_BGA2_AD20 7C7
TP_BGA2_B4 5C4
TP_BGA2_C5 5C4
TP_BGA2_E6 5C4
TP_BGA2_G4 7C7
TP_BGA2_H4 7C7
TP_BGA2_P20 6B3
TP_BGA2_P21 6B3
TP_BGA2_R2 7B7
TP_BGA2_R21 6B3
TP_BGA2_T21 6B3
TP_BGA2_U19 6B3
TP_BGA2_U21 6B3
TP_BGA2_U18 6B3
TP_BGA2_U20 6B3
TP_BGA2_U21 5C4
TP_BGA2_W2 6C3
TP_BGA2_W19 5B4
TP_BGA2_W21 5B4
TP_BGA2_Y1 6B3
TP_BGA2_Y2 6C3
TP_BGA2_Y21 5B4
TP_BUF24H 24A3
TP_CPURSV0 11B6
TP_CPURSV1 11B6
TP_DEBUG_GP1015 23C4
TP_DVO_1 42B6
TP_DVO_20 42B5
TP_DVO_29 42B5
TP_DVO_30 42B5
TP_DVO_47 42B6
TP_INIT* 24D5
TP_MCPX_AA19 24D7
TP_MCPX_AB17 24D7
TP_MCPX_H21 23C4
TP_MCPX_TD00 24C5
TP_MCPX_TD01 24C5

```

```

TP_MCPX_Y2 23B5
TP_MCPX_Y19 24D7
TP_MCPX_Y20 24D7
TP_PIC_10 49D5
TP_PRIIDE_32 37A2
TP_PRIIDE_34 37A2
TP_PRIIDE_39 37A3
TP_REF6 26B8
TP_ROM_CE* 24C7
TP_SA_GPI02 41B6
TRAY_STATE0 49C3 49C4
TRAY_STATE1 49C1 49C4
TRAY_STATE2 49C3 49C4
USBPWR_1 47D4
USBPWR_2 47C4
USBPWR_3 47C4
USBPWR_4 47B5
USB_1 23D7 47D1 47C7
USB_1* 23D7 47D1 47B7
USB_1FB 47D3
USB_1FB* 47D3
USB_1R 47D2
USB_1R* 47D2
USB_2 23D7 47C1 47A7
USB_2* 23D7 47C1 47A7
USB_2FB 47C3
USB_2FB* 47C3
USB_2R 47C2
USB_2R* 47C2
USB_3 23D7 47B1 47A6
USB_3* 23D7 47B1 47A6
USB_3FB 47B3
USB_3FB* 47B3
USB_3R 47B2
USB_3R* 47B2
USB_4 23D7 47A1 47A6
USB_4* 23C7 47A1 47A3
USB_4FB 47A3
USB_4FB* 47A3
USB_4R 47A2
USB_4R* 47A2
USB_5 23C7 25A1
USB_5* 23C7 25B1
USB_VREF 23C7
VID_CK_13PSM 29D2 41A6 42B7
VID_CK_13PSM_LR 29A6 29D5
VMODE0 44C1 49C4
VMODE0_R 44C2
VMODE1 44C1 49C4
VMODE1_R 44C2
VMODE2 44C1 49C4
VMODE2_R 44C2
VREG_1PS_GATE 26B8 31D8
VREG_2PS_GATE 26B8 31B8
VREG_CSN 26B5
VREG_CSP 26C5
VREG_CSP_R 26B3
VREG_FETDRVA 26C5
VREG_FETDRVA_FETDRVB_PN1 26C3
VREG_FETDRVB 26C5
VREG_PUCC 26D7
VREG_PARGOOD 26B6
VREG_UCC 26D8
VREG_UCCP_R 26C2
VREG_VO_SENSE 26A4
V_IPS 26C1 12B2 22D8 24A7 24C1 29B2 34D3
V_IPS_FEEDBACK 26A4
V_IPS_VTT 31C2 5C2 6D7 7B6 7D1 7D4 7D8 9D7
18C5 11B5 11C5 22D2 24B1 24C4 26A6
43D6

```

```

U_IP25_MEMVTT 30B2 18A3 18A6 18B3 18B6 18C6 18D2
18D6 18D8 19A3 19A6 19B3 19B6 19C6
19D3 19D6 19D8 20B5 20B8 20D3 20D5
20D8
U_2P5 31B3 7B7 11A3 11A4 11B4 11C1 11C4
12A7 12C7 12D4 14A6 14B2 14B7 15A2
15A7 16A6 16B2 16B7 17A2 17A7 20B2
20B5 20B6 20D3 20D5 20D8 21C5 21D1
21D2 21D6 21D7 22D5 26A6 28B6 28C6
30B7 38C6
U_3P3_FB 29A1 29A6 29C7
U_3P3_STBY 32D8 29A6 34D7 38A6 44D4 48B5 48D7
49B1 49C5 49D7
U_SPO_FILTERED 26D3 28D7 32A4 32B4
U_BAT_RTC 34C1 23B4
U_BAT_RTC_FET 34D3
U_CLKREF 7A5 7D8
U_CPUCORE 26C1 7C4 8D3 8D7 27C6 41A3
U_DVO_FB 41B2 43D4 12C1 13C8 41D1 41D4 42C4
43B6 43C8
U_DVO_REF 12B2
U_GTLREF 7B4 7B5 7D8
U_GTLREF_IP0 11A4 11B5
U_GTLREF_MCP 24B3 24D5
U_LAN_3P3V 35A3 35C8 35D1 36B7

```

DRAWING  
DUTFABP\_SCH\_1\_52  
Fri May 03 11:24:09 2002

INTEL	DOCUMENT NUMBER	PAGE	REV
CONFIDENTIAL	XXXXXX	52	12.0

	8	7	6	5	4	3	2	1																																																																																																																																																																																																																																																																																																																																																																																																																																																																																																																																																																																	
D	<p>*** Unit Cross-Reference ***          --- for the entire design ---</p> <table border="1"> <tr> <td>C1C1 CAPN</td> <td>7B5</td> <td>C2P7 CAPN</td> <td>8A5</td> <td>C3N2 CAPN</td> <td>49A5</td> <td>C4M12 CAPN</td> <td>43C2</td> </tr> <tr> <td>C1D1 CAPN</td> <td>5A1</td> <td>C2P8 CAPN</td> <td>8D6</td> <td>C3N3 CAPN</td> <td>31C5</td> <td>C4M13 CAPN</td> <td>43A2</td> </tr> <tr> <td>C1D2 CAPN</td> <td>22C1</td> <td>C2P9 CAPN</td> <td>9A5</td> <td>C3P1 CAPN</td> <td>22D1</td> <td>C4M14 CAPN</td> <td>42A2</td> </tr> <tr> <td>C1D3 CAPN</td> <td>6A2</td> <td>C2P10 CAPN</td> <td>8C6</td> <td>C3P2 CAPN</td> <td>22C1</td> <td>C4M15 CAPN</td> <td>43C5</td> </tr> <tr> <td>C1D4 CAPN</td> <td>7A6</td> <td>C2P11 CAPN</td> <td>8B6</td> <td>C3P3 CAPN</td> <td>11A5</td> <td>C4M16 CAPN</td> <td>43D4</td> </tr> <tr> <td>C1D5 CAPN</td> <td>7A6</td> <td>C2P12 CAPN</td> <td>8C5</td> <td>C3P4 CAPN</td> <td>12A1</td> <td>C4M17 CAPN</td> <td>43A5</td> </tr> <tr> <td>C1E1 CAP-P</td> <td>27C4</td> <td>C2P13 CAPN</td> <td>9C5</td> <td>C3P5 CAPN</td> <td>12A2</td> <td>C4M18 CAPN</td> <td>42A3</td> </tr> <tr> <td>C1F1 CAPN</td> <td>26D4</td> <td>C2P14 CAPN</td> <td>9C5</td> <td>C3R1 CAPN</td> <td>11A5</td> <td>C4N1 CAPN</td> <td>42C3</td> </tr> <tr> <td>C1F2 CAPN</td> <td>26D4</td> <td>C2P15 CAPN</td> <td>8C6</td> <td>C3R2 XCAP</td> <td>20A3</td> <td>C4N2 CAPN</td> <td>43A6</td> </tr> <tr> <td>C1G1 CAPN</td> <td>26D5</td> <td>C2P16 CAPN</td> <td>8D5</td> <td>C3T1 XCAP</td> <td>20A4</td> <td>C4N3 CAPN</td> <td>43A8</td> </tr> <tr> <td>C1G2 CAPN</td> <td>26D4</td> <td>C2P17 CAPN</td> <td>8C5</td> <td>C3T2 XCAP</td> <td>21C3</td> <td>C4N4 CAPN</td> <td>43D5</td> </tr> <tr> <td>C1G3 CAP-P</td> <td>47C5</td> <td>C2P18 CAPN</td> <td>8C5</td> <td>C3T3 XCAP</td> <td>20A3</td> <td>C4N5 CAPN</td> <td>43A5</td> </tr> <tr> <td>C1G4 CAPN</td> <td>47D3</td> <td>C2P19 CAPN</td> <td>9C6</td> <td>C3U1 XCAP</td> <td>20A3</td> <td>C4N6 CAPN</td> <td>43A7</td> </tr> <tr> <td>C1G5 CAPN</td> <td>47D4</td> <td>C2P20 CAPN</td> <td>8B6</td> <td>C3U2 XCAP</td> <td>21C7</td> <td>C4N7 CAPN</td> <td>43D4</td> </tr> <tr> <td>C1G6 CAP-P</td> <td>47D5</td> <td>C2P21 CAPN</td> <td>8B6</td> <td>C4A1 CAPN</td> <td>43A7</td> <td>C4N8 CAPN</td> <td>31D6</td> </tr> <tr> <td>C1G7 CAPN</td> <td>47C5</td> <td>C2P22 CAPN</td> <td>8B5</td> <td>C4A2 CAPN</td> <td>44C5</td> <td>C4N9 CAPN</td> <td>31D7</td> </tr> <tr> <td>C1P1 CAPN</td> <td>8B5</td> <td>C2P23 CAPN</td> <td>8B5</td> <td>C4A3 CAPN</td> <td>41C4</td> <td>C4P1 XCAP</td> <td>20A3</td> </tr> <tr> <td>C1P2 CAPN</td> <td>27B4</td> <td>C2P24 CAPN</td> <td>9A5</td> <td>C4A4 CAPN</td> <td>43D6</td> <td>C4P2 CAPN</td> <td>12B1</td> </tr> <tr> <td>C1P3 CAPN</td> <td>8D2</td> <td>C2R1 CAPN</td> <td>11C4</td> <td>C4A5 CAPN</td> <td>43C5</td> <td>C4P3 CAPN</td> <td>22D3</td> </tr> <tr> <td>C1P4 CAPN</td> <td>27B4</td> <td>C2R2 CAPN</td> <td>9C6</td> <td>C4A6 CAPN</td> <td>43C5</td> <td>C4P4 CAPN</td> <td>22A4</td> </tr> <tr> <td>C1P5 CAPN</td> <td>8B2</td> <td>C2R3 CAPN</td> <td>9B6</td> <td>C4A7 CAPN</td> <td>43C5</td> <td>C4P5 CAPN</td> <td>22B4</td> </tr> <tr> <td>C1P6 CAPN</td> <td>7A4</td> <td>C2R4 CAPN</td> <td>9B6</td> <td>C4A8 CAPN</td> <td>41A1</td> <td>C4P6 CAPN</td> <td>22B4</td> </tr> <tr> <td>C1P7 CAPN</td> <td>9B6</td> <td>C2R5 CAPN</td> <td>9C6</td> <td>C4B1 CAPN</td> <td>41A1</td> <td>C4P7 CAPN</td> <td>22A4</td> </tr> <tr> <td>C1P8 CAPN</td> <td>9B6</td> <td>C2R6 CAP-P</td> <td>7D5</td> <td>C4B2 CAPN</td> <td>41A2</td> <td>C4P8 CAPN</td> <td>22A4</td> </tr> <tr> <td>C1P9 CAPN</td> <td>8C2</td> <td>C2R7 CAPN</td> <td>26A7</td> <td>C4B3 CAPN</td> <td>43D4</td> <td>C4P9 CAPN</td> <td>22C3</td> </tr> <tr> <td>C1P10 CAPN</td> <td>9A6</td> <td>C2T1 CAPN</td> <td>26D7</td> <td>C4B4 CAPN</td> <td>31D7</td> <td>C4P10 CAPN</td> <td>22B4</td> </tr> <tr> <td>C1P11 CAPN</td> <td>9C6</td> <td>C2T2 CAPN</td> <td>33A4</td> <td>C4B5 CAPN</td> <td>31D8</td> <td>C4P11 CAPN</td> <td>33B6</td> </tr> <tr> <td>C1P12 CAPN</td> <td>7A5</td> <td>C2U1 CAPN</td> <td>26C2</td> <td>C4B6 CAPN</td> <td>12A1</td> <td>C4P12 XCAP</td> <td>22C5</td> </tr> <tr> <td>C1R1 CAPN</td> <td>9A6</td> <td>C2U2 CAPN</td> <td>49B1</td> <td>C4E1 XCAP</td> <td>21D7</td> <td>C4P13 XCAP</td> <td>22B5</td> </tr> <tr> <td>C1R2 CAPN</td> <td>8C2</td> <td>C2V1 CAPN</td> <td>32B1</td> <td>C4E2 XCAP</td> <td>20D2</td> <td>C4P14 XCAP</td> <td>22C3</td> </tr> <tr> <td>C1R3 CAPN</td> <td>8C2</td> <td>C3A1 CAPN</td> <td>33D5</td> <td>C4E3 XCAP</td> <td>21B4</td> <td>C4P15 XCAP</td> <td>22C5</td> </tr> <tr> <td>C1R4 CAPN</td> <td>27B5</td> <td>C3B1 CAPN</td> <td>11C5</td> <td>C4E4 XCAP</td> <td>20A3</td> <td>C4P16 CAPN</td> <td>22C3</td> </tr> <tr> <td>C1R5 CAPN</td> <td>27B5</td> <td>C3B2 CAPPDFPN</td> <td>31C6</td> <td>C4E5 XCAP</td> <td>20C2</td> <td>C4P17 CAPN</td> <td>11A6</td> </tr> <tr> <td>C1R6 CAPN</td> <td>8B2</td> <td>C3B3 CAPN</td> <td>31C5</td> <td>C4E6 XCAP</td> <td>21B5</td> <td>C4P18 CAPN</td> <td>22A7</td> </tr> <tr> <td>C1R7 CAPN</td> <td>8A5</td> <td>C3B4 CAPN</td> <td>31C4</td> <td>C4E7 XCAP</td> <td>20B3</td> <td>C4P19 CAP-P</td> <td>22C7</td> </tr> <tr> <td>C1R8 CAPN</td> <td>7A5</td> <td>C3B5 CAPN</td> <td>31C4</td> <td>C4E8 XCAP</td> <td>21B5</td> <td>C4P20 CAPN</td> <td>22B7</td> </tr> <tr> <td>C1R9 CAPN</td> <td>7A7</td> <td>C3B6 CAPN</td> <td>31C4</td> <td>C4F1 XCAP</td> <td>21C4</td> <td>C4P21 CAPN</td> <td>22C7</td> </tr> <tr> <td>C1T1 CAPN</td> <td>33D6</td> <td>C3B7 CAPN</td> <td>22C1</td> <td>C4F2 XCAP</td> <td>20C2</td> <td>C4P22 XCAP</td> <td>12C1</td> </tr> <tr> <td>C2D1 CAPN</td> <td>26D8</td> <td>C3D1 XCAP</td> <td>5A8</td> <td>C4F3 XCAP</td> <td>21A3</td> <td>C4P23 CAPN</td> <td>12C1</td> </tr> <tr> <td>C2D2 CAPN</td> <td>26B4</td> <td>C3D2 XCAP</td> <td>5A8</td> <td>C4F4 XCAP</td> <td>21B4</td> <td>C4R1 CAPN</td> <td>22A6</td> </tr> <tr> <td>C2D3 CAPN</td> <td>26A7</td> <td>C3E1 CAPN</td> <td>20B5</td> <td>C4F5 XCAP</td> <td>21A4</td> <td>C4R2 CAPN</td> <td>22B7</td> </tr> <tr> <td>C2E1 CAPN</td> <td>26D7</td> <td>C3E2 CAP-P</td> <td>27C4</td> <td>C4F6 CAPN</td> <td>16A3</td> <td>C4R3 XCAP</td> <td>22B5</td> </tr> <tr> <td>C2E2 CAPN</td> <td>26A4</td> <td>C3E3 XCAP</td> <td>20A5</td> <td>C4F7 XCAP</td> <td>20C2</td> <td>C4R4 CAPN</td> <td>22C7</td> </tr> <tr> <td>C2E3 CAP-P</td> <td>27C5</td> <td>C3E4 CAPN</td> <td>20B3</td> <td>C4F8 XCAP</td> <td>21C3</td> <td>C4R5 CAPN</td> <td>22B7</td> </tr> <tr> <td>C2E4 CAP-P</td> <td>27C3</td> <td>C3E5 XCAP</td> <td>21D3</td> <td>C4F9 CAP-P</td> <td>30B3</td> <td>C4R6 CAPN</td> <td>22C7</td> </tr> <tr> <td>C2E5 CAP-P</td> <td>27C3</td> <td>C3E6 XCAP</td> <td>21B3</td> <td>C4G1 CAPPDFPN</td> <td>30C5</td> <td>C4R7 XCAP</td> <td>22C5</td> </tr> <tr> <td>C2E6 CAPN</td> <td>32C5</td> <td>C3E7 XCAP</td> <td>21C5</td> <td>C4G2 CAPN</td> <td>30B4</td> <td>C4R8 CAPN</td> <td>11A4</td> </tr> <tr> <td>C2E7 CAPN</td> <td>32C6</td> <td>C3E8 XCAP</td> <td>20A5</td> <td>C4G3 CAPN</td> <td>30B5</td> <td>C4R9 XCAP</td> <td>22C5</td> </tr> <tr> <td>C2F1 CAP-P</td> <td>26D5</td> <td>C3E9 XCAP</td> <td>21D2</td> <td>C4G4 CAP-P</td> <td>47B6</td> <td>C4R10 XCAP</td> <td>22A5</td> </tr> <tr> <td>C2G1 CAPN</td> <td>32B1</td> <td>C3F1 XCAP</td> <td>20A5</td> <td>C4G5 CAPN</td> <td>47B5</td> <td>C4R11 XCAP</td> <td>22B5</td> </tr> <tr> <td>C2G2 CAPPDFPN</td> <td>32A1</td> <td>C3F2 XCAP</td> <td>21D2</td> <td>C4G6 CAPN</td> <td>47B4</td> <td>C4R12 CAPN</td> <td>22D6</td> </tr> <tr> <td>C2G3 CAPN</td> <td>47C5</td> <td>C3F3 CAPN</td> <td>32B2</td> <td>C4G7 CAPN</td> <td>47B3</td> <td>C4R13 CAPN</td> <td>22C6</td> </tr> <tr> <td>C2G4 CAPN</td> <td>47C3</td> <td>C3F4 CAPN</td> <td>32B2</td> <td>C4G8 CAP-P</td> <td>47B5</td> <td>C4R14 CAPN</td> <td>22C4</td> </tr> <tr> <td>C2G5 CAPN</td> <td>47C3</td> <td>C3F5 XCAP</td> <td>20A5</td> <td>C4G9 CAPN</td> <td>47B3</td> <td>C4R15 CAPN</td> <td>22D4</td> </tr> <tr> <td>C2G6 CAPN</td> <td>26D6</td> <td>C3F6 CAPPDFPN</td> <td>32A2</td> <td>C4G10 CAPN</td> <td>47A3</td> <td>C4R16 CAPN</td> <td>22B6</td> </tr> <tr> <td>C2G7 CAPN</td> <td>47D3</td> <td>C3F7 XCAP</td> <td>21A3</td> <td>C4G11 CAPN</td> <td>47B4</td> <td>C4R17 CAPN</td> <td>22B6</td> </tr> <tr> <td>C2G8 CAPN</td> <td>47D3</td> <td>C3F8 CAPN</td> <td>32B2</td> <td>C4G12 CAPN</td> <td>47B5</td> <td>C4R18 CAPN</td> <td>22C4</td> </tr> <tr> <td>C2G9 CAPN</td> <td>47D7</td> <td>C3F9 CAPN</td> <td>32B2</td> <td>C4G13 CAPN</td> <td>47A3</td> <td>C4R19 CAPN</td> <td>22C4</td> </tr> <tr> <td>C2G10 CAPN</td> <td>47C4</td> <td>C3F10 CAPPDFPN</td> <td>31B6</td> <td>C4G14 CAPN</td> <td>30B5</td> <td>C4R20 XCAP</td> <td>12D4</td> </tr> <tr> <td>C2N1 CAP-P</td> <td>31C3</td> <td>C3F11 CAPN</td> <td>32A2</td> <td>C4M1 CAPN</td> <td>44C5</td> <td>C4R21 XCAP</td> <td>20B3</td> </tr> <tr> <td>C2N2 CAP-P</td> <td>31C3</td> <td>C3G1 CAPPDFPN</td> <td>32A2</td> <td>C4M2 XCAP</td> <td>43C1</td> <td>C4T1 XCAP</td> <td>21C7</td> </tr> <tr> <td>C2P1 CAPN</td> <td>7A5</td> <td>C3G2 CAPN</td> <td>26D6</td> <td>C4M3 XCAP</td> <td>43C1</td> <td>C4T2 XCAP</td> <td>20B4</td> </tr> <tr> <td>C2P2 CAPN</td> <td>9B5</td> <td>C3G3 CAPN</td> <td>47B7</td> <td>C4M4 XCAP</td> <td>43B1</td> <td>C4T3 XCAP</td> <td>20A4</td> </tr> <tr> <td>C2P3 CAPN</td> <td>9C5</td> <td>C3G4 CAPN</td> <td>32B2</td> <td>C4M5 CAPN</td> <td>43A2</td> <td>C4T4 XCAP</td> <td>20D1</td> </tr> <tr> <td>C2P4 CAPN</td> <td>9B5</td> <td>C3G5 CAPN</td> <td>32B2</td> <td>C4M6 CAPN</td> <td>42A4</td> <td>C4T5 XCAP</td> <td>21B4</td> </tr> <tr> <td>C2P5 CAPN</td> <td>9B5</td> <td>C3G6 CAPN</td> <td>32A2</td> <td>C4M7 CAPN</td> <td>43A6</td> <td>C4T6 XCAP</td> <td>20C1</td> </tr> <tr> <td>C2P6 CAPN</td> <td>9B5</td> <td>C3G7 CAPN</td> <td>32B2</td> <td>C4M8 CAPN</td> <td>43A6</td> <td>C4U1 XCAP</td> <td>20A4</td> </tr> <tr> <td></td> <td></td> <td>C3G8 CAPN</td> <td>32B3</td> <td>C4M9 CAPN</td> <td>42A3</td> <td>C4U2 XCAP</td> <td>21A8</td> </tr> <tr> <td></td> <td></td> <td>C3G9 CAPN</td> <td>32C7</td> <td>C4M10 CAPN</td> <td>43B2</td> <td>C4U3 XCAP</td> <td>21B5</td> </tr> <tr> <td></td> <td></td> <td>C3N1 CAPN</td> <td>49A6</td> <td>C4M11 CAPN</td> <td>43C2</td> <td>C4U4 XCAP</td> <td>20A4</td> </tr> </table>								C1C1 CAPN	7B5	C2P7 CAPN	8A5	C3N2 CAPN	49A5	C4M12 CAPN	43C2	C1D1 CAPN	5A1	C2P8 CAPN	8D6	C3N3 CAPN	31C5	C4M13 CAPN	43A2	C1D2 CAPN	22C1	C2P9 CAPN	9A5	C3P1 CAPN	22D1	C4M14 CAPN	42A2	C1D3 CAPN	6A2	C2P10 CAPN	8C6	C3P2 CAPN	22C1	C4M15 CAPN	43C5	C1D4 CAPN	7A6	C2P11 CAPN	8B6	C3P3 CAPN	11A5	C4M16 CAPN	43D4	C1D5 CAPN	7A6	C2P12 CAPN	8C5	C3P4 CAPN	12A1	C4M17 CAPN	43A5	C1E1 CAP-P	27C4	C2P13 CAPN	9C5	C3P5 CAPN	12A2	C4M18 CAPN	42A3	C1F1 CAPN	26D4	C2P14 CAPN	9C5	C3R1 CAPN	11A5	C4N1 CAPN	42C3	C1F2 CAPN	26D4	C2P15 CAPN	8C6	C3R2 XCAP	20A3	C4N2 CAPN	43A6	C1G1 CAPN	26D5	C2P16 CAPN	8D5	C3T1 XCAP	20A4	C4N3 CAPN	43A8	C1G2 CAPN	26D4	C2P17 CAPN	8C5	C3T2 XCAP	21C3	C4N4 CAPN	43D5	C1G3 CAP-P	47C5	C2P18 CAPN	8C5	C3T3 XCAP	20A3	C4N5 CAPN	43A5	C1G4 CAPN	47D3	C2P19 CAPN	9C6	C3U1 XCAP	20A3	C4N6 CAPN	43A7	C1G5 CAPN	47D4	C2P20 CAPN	8B6	C3U2 XCAP	21C7	C4N7 CAPN	43D4	C1G6 CAP-P	47D5	C2P21 CAPN	8B6	C4A1 CAPN	43A7	C4N8 CAPN	31D6	C1G7 CAPN	47C5	C2P22 CAPN	8B5	C4A2 CAPN	44C5	C4N9 CAPN	31D7	C1P1 CAPN	8B5	C2P23 CAPN	8B5	C4A3 CAPN	41C4	C4P1 XCAP	20A3	C1P2 CAPN	27B4	C2P24 CAPN	9A5	C4A4 CAPN	43D6	C4P2 CAPN	12B1	C1P3 CAPN	8D2	C2R1 CAPN	11C4	C4A5 CAPN	43C5	C4P3 CAPN	22D3	C1P4 CAPN	27B4	C2R2 CAPN	9C6	C4A6 CAPN	43C5	C4P4 CAPN	22A4	C1P5 CAPN	8B2	C2R3 CAPN	9B6	C4A7 CAPN	43C5	C4P5 CAPN	22B4	C1P6 CAPN	7A4	C2R4 CAPN	9B6	C4A8 CAPN	41A1	C4P6 CAPN	22B4	C1P7 CAPN	9B6	C2R5 CAPN	9C6	C4B1 CAPN	41A1	C4P7 CAPN	22A4	C1P8 CAPN	9B6	C2R6 CAP-P	7D5	C4B2 CAPN	41A2	C4P8 CAPN	22A4	C1P9 CAPN	8C2	C2R7 CAPN	26A7	C4B3 CAPN	43D4	C4P9 CAPN	22C3	C1P10 CAPN	9A6	C2T1 CAPN	26D7	C4B4 CAPN	31D7	C4P10 CAPN	22B4	C1P11 CAPN	9C6	C2T2 CAPN	33A4	C4B5 CAPN	31D8	C4P11 CAPN	33B6	C1P12 CAPN	7A5	C2U1 CAPN	26C2	C4B6 CAPN	12A1	C4P12 XCAP	22C5	C1R1 CAPN	9A6	C2U2 CAPN	49B1	C4E1 XCAP	21D7	C4P13 XCAP	22B5	C1R2 CAPN	8C2	C2V1 CAPN	32B1	C4E2 XCAP	20D2	C4P14 XCAP	22C3	C1R3 CAPN	8C2	C3A1 CAPN	33D5	C4E3 XCAP	21B4	C4P15 XCAP	22C5	C1R4 CAPN	27B5	C3B1 CAPN	11C5	C4E4 XCAP	20A3	C4P16 CAPN	22C3	C1R5 CAPN	27B5	C3B2 CAPPDFPN	31C6	C4E5 XCAP	20C2	C4P17 CAPN	11A6	C1R6 CAPN	8B2	C3B3 CAPN	31C5	C4E6 XCAP	21B5	C4P18 CAPN	22A7	C1R7 CAPN	8A5	C3B4 CAPN	31C4	C4E7 XCAP	20B3	C4P19 CAP-P	22C7	C1R8 CAPN	7A5	C3B5 CAPN	31C4	C4E8 XCAP	21B5	C4P20 CAPN	22B7	C1R9 CAPN	7A7	C3B6 CAPN	31C4	C4F1 XCAP	21C4	C4P21 CAPN	22C7	C1T1 CAPN	33D6	C3B7 CAPN	22C1	C4F2 XCAP	20C2	C4P22 XCAP	12C1	C2D1 CAPN	26D8	C3D1 XCAP	5A8	C4F3 XCAP	21A3	C4P23 CAPN	12C1	C2D2 CAPN	26B4	C3D2 XCAP	5A8	C4F4 XCAP	21B4	C4R1 CAPN	22A6	C2D3 CAPN	26A7	C3E1 CAPN	20B5	C4F5 XCAP	21A4	C4R2 CAPN	22B7	C2E1 CAPN	26D7	C3E2 CAP-P	27C4	C4F6 CAPN	16A3	C4R3 XCAP	22B5	C2E2 CAPN	26A4	C3E3 XCAP	20A5	C4F7 XCAP	20C2	C4R4 CAPN	22C7	C2E3 CAP-P	27C5	C3E4 CAPN	20B3	C4F8 XCAP	21C3	C4R5 CAPN	22B7	C2E4 CAP-P	27C3	C3E5 XCAP	21D3	C4F9 CAP-P	30B3	C4R6 CAPN	22C7	C2E5 CAP-P	27C3	C3E6 XCAP	21B3	C4G1 CAPPDFPN	30C5	C4R7 XCAP	22C5	C2E6 CAPN	32C5	C3E7 XCAP	21C5	C4G2 CAPN	30B4	C4R8 CAPN	11A4	C2E7 CAPN	32C6	C3E8 XCAP	20A5	C4G3 CAPN	30B5	C4R9 XCAP	22C5	C2F1 CAP-P	26D5	C3E9 XCAP	21D2	C4G4 CAP-P	47B6	C4R10 XCAP	22A5	C2G1 CAPN	32B1	C3F1 XCAP	20A5	C4G5 CAPN	47B5	C4R11 XCAP	22B5	C2G2 CAPPDFPN	32A1	C3F2 XCAP	21D2	C4G6 CAPN	47B4	C4R12 CAPN	22D6	C2G3 CAPN	47C5	C3F3 CAPN	32B2	C4G7 CAPN	47B3	C4R13 CAPN	22C6	C2G4 CAPN	47C3	C3F4 CAPN	32B2	C4G8 CAP-P	47B5	C4R14 CAPN	22C4	C2G5 CAPN	47C3	C3F5 XCAP	20A5	C4G9 CAPN	47B3	C4R15 CAPN	22D4	C2G6 CAPN	26D6	C3F6 CAPPDFPN	32A2	C4G10 CAPN	47A3	C4R16 CAPN	22B6	C2G7 CAPN	47D3	C3F7 XCAP	21A3	C4G11 CAPN	47B4	C4R17 CAPN	22B6	C2G8 CAPN	47D3	C3F8 CAPN	32B2	C4G12 CAPN	47B5	C4R18 CAPN	22C4	C2G9 CAPN	47D7	C3F9 CAPN	32B2	C4G13 CAPN	47A3	C4R19 CAPN	22C4	C2G10 CAPN	47C4	C3F10 CAPPDFPN	31B6	C4G14 CAPN	30B5	C4R20 XCAP	12D4	C2N1 CAP-P	31C3	C3F11 CAPN	32A2	C4M1 CAPN	44C5	C4R21 XCAP	20B3	C2N2 CAP-P	31C3	C3G1 CAPPDFPN	32A2	C4M2 XCAP	43C1	C4T1 XCAP	21C7	C2P1 CAPN	7A5	C3G2 CAPN	26D6	C4M3 XCAP	43C1	C4T2 XCAP	20B4	C2P2 CAPN	9B5	C3G3 CAPN	47B7	C4M4 XCAP	43B1	C4T3 XCAP	20A4	C2P3 CAPN	9C5	C3G4 CAPN	32B2	C4M5 CAPN	43A2	C4T4 XCAP	20D1	C2P4 CAPN	9B5	C3G5 CAPN	32B2	C4M6 CAPN	42A4	C4T5 XCAP	21B4	C2P5 CAPN	9B5	C3G6 CAPN	32A2	C4M7 CAPN	43A6	C4T6 XCAP	20C1	C2P6 CAPN	9B5	C3G7 CAPN	32B2	C4M8 CAPN	43A6	C4U1 XCAP	20A4			C3G8 CAPN	32B3	C4M9 CAPN	42A3	C4U2 XCAP	21A8			C3G9 CAPN	32C7	C4M10 CAPN	43B2	C4U3 XCAP	21B5			C3N1 CAPN	49A6	C4M11 CAPN	43C2	C4U4 XCAP	20A4	C
C1C1 CAPN	7B5	C2P7 CAPN	8A5	C3N2 CAPN	49A5	C4M12 CAPN	43C2																																																																																																																																																																																																																																																																																																																																																																																																																																																																																																																																																																																		
C1D1 CAPN	5A1	C2P8 CAPN	8D6	C3N3 CAPN	31C5	C4M13 CAPN	43A2																																																																																																																																																																																																																																																																																																																																																																																																																																																																																																																																																																																		
C1D2 CAPN	22C1	C2P9 CAPN	9A5	C3P1 CAPN	22D1	C4M14 CAPN	42A2																																																																																																																																																																																																																																																																																																																																																																																																																																																																																																																																																																																		
C1D3 CAPN	6A2	C2P10 CAPN	8C6	C3P2 CAPN	22C1	C4M15 CAPN	43C5																																																																																																																																																																																																																																																																																																																																																																																																																																																																																																																																																																																		
C1D4 CAPN	7A6	C2P11 CAPN	8B6	C3P3 CAPN	11A5	C4M16 CAPN	43D4																																																																																																																																																																																																																																																																																																																																																																																																																																																																																																																																																																																		
C1D5 CAPN	7A6	C2P12 CAPN	8C5	C3P4 CAPN	12A1	C4M17 CAPN	43A5																																																																																																																																																																																																																																																																																																																																																																																																																																																																																																																																																																																		
C1E1 CAP-P	27C4	C2P13 CAPN	9C5	C3P5 CAPN	12A2	C4M18 CAPN	42A3																																																																																																																																																																																																																																																																																																																																																																																																																																																																																																																																																																																		
C1F1 CAPN	26D4	C2P14 CAPN	9C5	C3R1 CAPN	11A5	C4N1 CAPN	42C3																																																																																																																																																																																																																																																																																																																																																																																																																																																																																																																																																																																		
C1F2 CAPN	26D4	C2P15 CAPN	8C6	C3R2 XCAP	20A3	C4N2 CAPN	43A6																																																																																																																																																																																																																																																																																																																																																																																																																																																																																																																																																																																		
C1G1 CAPN	26D5	C2P16 CAPN	8D5	C3T1 XCAP	20A4	C4N3 CAPN	43A8																																																																																																																																																																																																																																																																																																																																																																																																																																																																																																																																																																																		
C1G2 CAPN	26D4	C2P17 CAPN	8C5	C3T2 XCAP	21C3	C4N4 CAPN	43D5																																																																																																																																																																																																																																																																																																																																																																																																																																																																																																																																																																																		
C1G3 CAP-P	47C5	C2P18 CAPN	8C5	C3T3 XCAP	20A3	C4N5 CAPN	43A5																																																																																																																																																																																																																																																																																																																																																																																																																																																																																																																																																																																		
C1G4 CAPN	47D3	C2P19 CAPN	9C6	C3U1 XCAP	20A3	C4N6 CAPN	43A7																																																																																																																																																																																																																																																																																																																																																																																																																																																																																																																																																																																		
C1G5 CAPN	47D4	C2P20 CAPN	8B6	C3U2 XCAP	21C7	C4N7 CAPN	43D4																																																																																																																																																																																																																																																																																																																																																																																																																																																																																																																																																																																		
C1G6 CAP-P	47D5	C2P21 CAPN	8B6	C4A1 CAPN	43A7	C4N8 CAPN	31D6																																																																																																																																																																																																																																																																																																																																																																																																																																																																																																																																																																																		
C1G7 CAPN	47C5	C2P22 CAPN	8B5	C4A2 CAPN	44C5	C4N9 CAPN	31D7																																																																																																																																																																																																																																																																																																																																																																																																																																																																																																																																																																																		
C1P1 CAPN	8B5	C2P23 CAPN	8B5	C4A3 CAPN	41C4	C4P1 XCAP	20A3																																																																																																																																																																																																																																																																																																																																																																																																																																																																																																																																																																																		
C1P2 CAPN	27B4	C2P24 CAPN	9A5	C4A4 CAPN	43D6	C4P2 CAPN	12B1																																																																																																																																																																																																																																																																																																																																																																																																																																																																																																																																																																																		
C1P3 CAPN	8D2	C2R1 CAPN	11C4	C4A5 CAPN	43C5	C4P3 CAPN	22D3																																																																																																																																																																																																																																																																																																																																																																																																																																																																																																																																																																																		
C1P4 CAPN	27B4	C2R2 CAPN	9C6	C4A6 CAPN	43C5	C4P4 CAPN	22A4																																																																																																																																																																																																																																																																																																																																																																																																																																																																																																																																																																																		
C1P5 CAPN	8B2	C2R3 CAPN	9B6	C4A7 CAPN	43C5	C4P5 CAPN	22B4																																																																																																																																																																																																																																																																																																																																																																																																																																																																																																																																																																																		
C1P6 CAPN	7A4	C2R4 CAPN	9B6	C4A8 CAPN	41A1	C4P6 CAPN	22B4																																																																																																																																																																																																																																																																																																																																																																																																																																																																																																																																																																																		
C1P7 CAPN	9B6	C2R5 CAPN	9C6	C4B1 CAPN	41A1	C4P7 CAPN	22A4																																																																																																																																																																																																																																																																																																																																																																																																																																																																																																																																																																																		
C1P8 CAPN	9B6	C2R6 CAP-P	7D5	C4B2 CAPN	41A2	C4P8 CAPN	22A4																																																																																																																																																																																																																																																																																																																																																																																																																																																																																																																																																																																		
C1P9 CAPN	8C2	C2R7 CAPN	26A7	C4B3 CAPN	43D4	C4P9 CAPN	22C3																																																																																																																																																																																																																																																																																																																																																																																																																																																																																																																																																																																		
C1P10 CAPN	9A6	C2T1 CAPN	26D7	C4B4 CAPN	31D7	C4P10 CAPN	22B4																																																																																																																																																																																																																																																																																																																																																																																																																																																																																																																																																																																		
C1P11 CAPN	9C6	C2T2 CAPN	33A4	C4B5 CAPN	31D8	C4P11 CAPN	33B6																																																																																																																																																																																																																																																																																																																																																																																																																																																																																																																																																																																		
C1P12 CAPN	7A5	C2U1 CAPN	26C2	C4B6 CAPN	12A1	C4P12 XCAP	22C5																																																																																																																																																																																																																																																																																																																																																																																																																																																																																																																																																																																		
C1R1 CAPN	9A6	C2U2 CAPN	49B1	C4E1 XCAP	21D7	C4P13 XCAP	22B5																																																																																																																																																																																																																																																																																																																																																																																																																																																																																																																																																																																		
C1R2 CAPN	8C2	C2V1 CAPN	32B1	C4E2 XCAP	20D2	C4P14 XCAP	22C3																																																																																																																																																																																																																																																																																																																																																																																																																																																																																																																																																																																		
C1R3 CAPN	8C2	C3A1 CAPN	33D5	C4E3 XCAP	21B4	C4P15 XCAP	22C5																																																																																																																																																																																																																																																																																																																																																																																																																																																																																																																																																																																		
C1R4 CAPN	27B5	C3B1 CAPN	11C5	C4E4 XCAP	20A3	C4P16 CAPN	22C3																																																																																																																																																																																																																																																																																																																																																																																																																																																																																																																																																																																		
C1R5 CAPN	27B5	C3B2 CAPPDFPN	31C6	C4E5 XCAP	20C2	C4P17 CAPN	11A6																																																																																																																																																																																																																																																																																																																																																																																																																																																																																																																																																																																		
C1R6 CAPN	8B2	C3B3 CAPN	31C5	C4E6 XCAP	21B5	C4P18 CAPN	22A7																																																																																																																																																																																																																																																																																																																																																																																																																																																																																																																																																																																		
C1R7 CAPN	8A5	C3B4 CAPN	31C4	C4E7 XCAP	20B3	C4P19 CAP-P	22C7																																																																																																																																																																																																																																																																																																																																																																																																																																																																																																																																																																																		
C1R8 CAPN	7A5	C3B5 CAPN	31C4	C4E8 XCAP	21B5	C4P20 CAPN	22B7																																																																																																																																																																																																																																																																																																																																																																																																																																																																																																																																																																																		
C1R9 CAPN	7A7	C3B6 CAPN	31C4	C4F1 XCAP	21C4	C4P21 CAPN	22C7																																																																																																																																																																																																																																																																																																																																																																																																																																																																																																																																																																																		
C1T1 CAPN	33D6	C3B7 CAPN	22C1	C4F2 XCAP	20C2	C4P22 XCAP	12C1																																																																																																																																																																																																																																																																																																																																																																																																																																																																																																																																																																																		
C2D1 CAPN	26D8	C3D1 XCAP	5A8	C4F3 XCAP	21A3	C4P23 CAPN	12C1																																																																																																																																																																																																																																																																																																																																																																																																																																																																																																																																																																																		
C2D2 CAPN	26B4	C3D2 XCAP	5A8	C4F4 XCAP	21B4	C4R1 CAPN	22A6																																																																																																																																																																																																																																																																																																																																																																																																																																																																																																																																																																																		
C2D3 CAPN	26A7	C3E1 CAPN	20B5	C4F5 XCAP	21A4	C4R2 CAPN	22B7																																																																																																																																																																																																																																																																																																																																																																																																																																																																																																																																																																																		
C2E1 CAPN	26D7	C3E2 CAP-P	27C4	C4F6 CAPN	16A3	C4R3 XCAP	22B5																																																																																																																																																																																																																																																																																																																																																																																																																																																																																																																																																																																		
C2E2 CAPN	26A4	C3E3 XCAP	20A5	C4F7 XCAP	20C2	C4R4 CAPN	22C7																																																																																																																																																																																																																																																																																																																																																																																																																																																																																																																																																																																		
C2E3 CAP-P	27C5	C3E4 CAPN	20B3	C4F8 XCAP	21C3	C4R5 CAPN	22B7																																																																																																																																																																																																																																																																																																																																																																																																																																																																																																																																																																																		
C2E4 CAP-P	27C3	C3E5 XCAP	21D3	C4F9 CAP-P	30B3	C4R6 CAPN	22C7																																																																																																																																																																																																																																																																																																																																																																																																																																																																																																																																																																																		
C2E5 CAP-P	27C3	C3E6 XCAP	21B3	C4G1 CAPPDFPN	30C5	C4R7 XCAP	22C5																																																																																																																																																																																																																																																																																																																																																																																																																																																																																																																																																																																		
C2E6 CAPN	32C5	C3E7 XCAP	21C5	C4G2 CAPN	30B4	C4R8 CAPN	11A4																																																																																																																																																																																																																																																																																																																																																																																																																																																																																																																																																																																		
C2E7 CAPN	32C6	C3E8 XCAP	20A5	C4G3 CAPN	30B5	C4R9 XCAP	22C5																																																																																																																																																																																																																																																																																																																																																																																																																																																																																																																																																																																		
C2F1 CAP-P	26D5	C3E9 XCAP	21D2	C4G4 CAP-P	47B6	C4R10 XCAP	22A5																																																																																																																																																																																																																																																																																																																																																																																																																																																																																																																																																																																		
C2G1 CAPN	32B1	C3F1 XCAP	20A5	C4G5 CAPN	47B5	C4R11 XCAP	22B5																																																																																																																																																																																																																																																																																																																																																																																																																																																																																																																																																																																		
C2G2 CAPPDFPN	32A1	C3F2 XCAP	21D2	C4G6 CAPN	47B4	C4R12 CAPN	22D6																																																																																																																																																																																																																																																																																																																																																																																																																																																																																																																																																																																		
C2G3 CAPN	47C5	C3F3 CAPN	32B2	C4G7 CAPN	47B3	C4R13 CAPN	22C6																																																																																																																																																																																																																																																																																																																																																																																																																																																																																																																																																																																		
C2G4 CAPN	47C3	C3F4 CAPN	32B2	C4G8 CAP-P	47B5	C4R14 CAPN	22C4																																																																																																																																																																																																																																																																																																																																																																																																																																																																																																																																																																																		
C2G5 CAPN	47C3	C3F5 XCAP	20A5	C4G9 CAPN	47B3	C4R15 CAPN	22D4																																																																																																																																																																																																																																																																																																																																																																																																																																																																																																																																																																																		
C2G6 CAPN	26D6	C3F6 CAPPDFPN	32A2	C4G10 CAPN	47A3	C4R16 CAPN	22B6																																																																																																																																																																																																																																																																																																																																																																																																																																																																																																																																																																																		
C2G7 CAPN	47D3	C3F7 XCAP	21A3	C4G11 CAPN	47B4	C4R17 CAPN	22B6																																																																																																																																																																																																																																																																																																																																																																																																																																																																																																																																																																																		
C2G8 CAPN	47D3	C3F8 CAPN	32B2	C4G12 CAPN	47B5	C4R18 CAPN	22C4																																																																																																																																																																																																																																																																																																																																																																																																																																																																																																																																																																																		
C2G9 CAPN	47D7	C3F9 CAPN	32B2	C4G13 CAPN	47A3	C4R19 CAPN	22C4																																																																																																																																																																																																																																																																																																																																																																																																																																																																																																																																																																																		
C2G10 CAPN	47C4	C3F10 CAPPDFPN	31B6	C4G14 CAPN	30B5	C4R20 XCAP	12D4																																																																																																																																																																																																																																																																																																																																																																																																																																																																																																																																																																																		
C2N1 CAP-P	31C3	C3F11 CAPN	32A2	C4M1 CAPN	44C5	C4R21 XCAP	20B3																																																																																																																																																																																																																																																																																																																																																																																																																																																																																																																																																																																		
C2N2 CAP-P	31C3	C3G1 CAPPDFPN	32A2	C4M2 XCAP	43C1	C4T1 XCAP	21C7																																																																																																																																																																																																																																																																																																																																																																																																																																																																																																																																																																																		
C2P1 CAPN	7A5	C3G2 CAPN	26D6	C4M3 XCAP	43C1	C4T2 XCAP	20B4																																																																																																																																																																																																																																																																																																																																																																																																																																																																																																																																																																																		
C2P2 CAPN	9B5	C3G3 CAPN	47B7	C4M4 XCAP	43B1	C4T3 XCAP	20A4																																																																																																																																																																																																																																																																																																																																																																																																																																																																																																																																																																																		
C2P3 CAPN	9C5	C3G4 CAPN	32B2	C4M5 CAPN	43A2	C4T4 XCAP	20D1																																																																																																																																																																																																																																																																																																																																																																																																																																																																																																																																																																																		
C2P4 CAPN	9B5	C3G5 CAPN	32B2	C4M6 CAPN	42A4	C4T5 XCAP	21B4																																																																																																																																																																																																																																																																																																																																																																																																																																																																																																																																																																																		
C2P5 CAPN	9B5	C3G6 CAPN	32A2	C4M7 CAPN	43A6	C4T6 XCAP	20C1																																																																																																																																																																																																																																																																																																																																																																																																																																																																																																																																																																																		
C2P6 CAPN	9B5	C3G7 CAPN	32B2	C4M8 CAPN	43A6	C4U1 XCAP	20A4																																																																																																																																																																																																																																																																																																																																																																																																																																																																																																																																																																																		
		C3G8 CAPN	32B3	C4M9 CAPN	42A3	C4U2 XCAP	21A8																																																																																																																																																																																																																																																																																																																																																																																																																																																																																																																																																																																		
		C3G9 CAPN	32C7	C4M10 CAPN	43B2	C4U3 XCAP	21B5																																																																																																																																																																																																																																																																																																																																																																																																																																																																																																																																																																																		
		C3N1 CAPN	49A6	C4M11 CAPN	43C2	C4U4 XCAP	20A4																																																																																																																																																																																																																																																																																																																																																																																																																																																																																																																																																																																		
B									B																																																																																																																																																																																																																																																																																																																																																																																																																																																																																																																																																																																
A									A																																																																																																																																																																																																																																																																																																																																																																																																																																																																																																																																																																																
	8	7	6	5	4	3	2	1																																																																																																																																																																																																																																																																																																																																																																																																																																																																																																																																																																																	

DRAWING  
 DUTFABP\_SCH 1: 53  
 Fri May 03 11:24:09 2002

INTEL CONFIDENTIAL	DOCUMENT NUMBER XXXXXX	PAGE 53	REV 12.0
-----------------------	---------------------------	------------	-------------

	8	7	6	5	4	3	2	1
D								
C								
B								
A								
	8	7	6	5	4	3	2	1

C4U5 XCAP 21A4 C4U6 XCAP 21B3 C4U7 CAPN 1796 C4U1 CAPN 32B5 C4V2 CAPN 47D7 C5A1 XCAP 44B6 C5A2 CAPN 39C2 C5A3 CAPN 39B2 C5A4 CAP-P 40C5 C5A5 CAPN 41B3 C5A6 CAPN 41A4 C5A7 CAPN 44C4 C5A8 CAPN 44C3 C5A9 CAPN 44C3 C5B1 CAPN 33B3 C5B2 CAPN 40A6 C5B3 CAPN 41A3 C5B4 XCAP 21B8 C5B5 XCAP 21B8 C5B6 CAPN 20D6 C5C1 XCAP 21B8 C5C2 CAPN 20D7 C5C3 XCAP 21A8 C5C4 XCAP 21C5 C5C5 XCAP 20B6 C5C6 XCAP 20D7 C5D1 CAPN 20D3 C5D2 CAPN 20D5 C5D3 XCAP 21A7 C5D4 XCAP 20D5 C5D5 XCAP 21C2 C5D6 XCAP 20C5 C5E1 CAPN 20D2 C5E2 CAPN 20D1 C5E3 CAPN 20B6 C5E4 XCAP 21D7 C5E5 XCAP 20C1 C5F1 XCAP 21B3 C5F2 CAPN 16A2 C5F3 CAPN 16A2 C5F4 CAPPDFPN 31B3 C5F5 CAPPDFPN 31B6 C5G1 CAPPDFPN 31B4 C5G2 CAPN 31B5 C5G3 CAPN 31B4 C5G4 CAPN 31B5 C5N1 CAPN 44D8 C5N2 CAPN 44C5 C5N3 CAPN 43A7 C5N4 CAPN 43A7 C5M5 CAP-P 43C6 C5M6 CAPN 40B5 C5M7 CAPN 39A5 C5N1 CAPN 40D6 C5N2 CAPN 40A5 C5N3 CAPN 40C8 C5N4 CAPN 40C7 C5N5 XCAP 20D7 C5N6 XCAP 20D7 C5N7 XCAP 21C4 C5N8 XCAP 20C7 C5N9 XCAP 21C8 C5P1 XCAP 20A3 C5P2 XCAP 11C1 C5P3 XCAP 20C4 C5P4 XCAP 21B5 C5P5 XCAP 20A2 C5P6 XCAP 20C4 C5R1 XCAP 21B7 C5R2 XCAP 20A3	CST1 CAPN 22B6 CST2 XCAP 20C2 CST3 XCAP 21D3 CST4 XCAP 21C3 CST5 XCAP 21D7 CST6 XCAP 20C2 CST7 XCAP 20C1 CST8 XCAP 20D2 CST9 XCAP 21B4 CSU1 XCAP 20D2 CSU2 XCAP 21B4 CSU3 XCAP 20C2 CBA1 CAPN 46C3 CBA2 CAPN 33A4 CBA3 CAP-P 40B7 CBA4 CAP-P 38C6 CBA5 CAPN 39D7 CBA6 CAPN 38B6 CBA7 CAPN 38B6 CBA8 CAPN 39D5 CBA9 CAPN 38C7 CBA10 CAP-P 39B4 CBA11 CAP-P 39D4 CBA12 CAPN 39C6 CBA13 CAPN 39C5 CBA2 CAPN 39A6 CBB3 CAPN 38B3 CBB4 CAP-P 39C6 CBB5 CAPN 38C3 CBB6 CAP-P 39A6 CBB7 XCAP 21D8 CBB8 CAP-P 20A6 CBB9 XCAP 20C6 CBB10 XCAP 20C6 CBB11 XCAP 21C8 CBB12 CAPN 49B5 CSC2 CAPN 14A1 CEC3 XCAP 21B8 CEC4 XCAP 21C4 CEC5 XCAP 21B5 CEC6 CAPN 14A2 CEC7 CAPN 14A3 CEC8 XCAP 20C7 CEC9 XCAP 20C7 CEC10 XCAP 20C3 CEC11 XCAP 21C7 CEC12 XCAP 21A3 CEC13 XCAP 20D3 CED1 XCAP 21D3 CED2 XCAP 21A7 CED3 XCAP 21C4 CED4 XCAP 21A5 CED5 CAPN 15A3 CED6 XCAP 20C5 CED7 XCAP 20C5 CEB1 CAPN 23A5 CEB2 CAP-P 23A5 CES3 CAPN 33A6 CEB4 CAPN 23A2 CES5 CAPN 23A1 CBF1 CAPN 24B4 CBF2 CAPN 36B1 CBF3 CAPN 36C3 CBF4 CAPN 24B4 CBF5 CAPN 34B3 CBF6 CAPN 33A6 CBG1 CAPPDFPN 33D3 CBG2 CAPPDFPN 31B3 CBG3 CAPPDFPN 31C8 CBG4 CAPN 31C7 CBG5 CAPN 31C7 CBG6 CAPN 31C8 CBG1 CAPN 44D7 CBG2 CAPN 39D4 CBG3 CAPN 39B5 CBG4 CAPN 38B3 CBG5 CAPN 38B4 CBG1 XCAP 43B6 CBG2 CAPN 39B7 CBG3 XCAP 20C7 CBG4 XCAP 21A5 CBG6 CAPN 20A7 CBG9 XCAP 21D8 CBP1 XCAP 21D8 CBP2 XCAP 20D6 CBP3 XCAP 20C6 CBP4 XCAP 20D4 CBP5 XCAP 20C4 CBP6 CAPN 15A7 CBP7 XCAP 20D4 CBP8 CAPN 20A7 CBP9 XCAP 21B7 CBP10 XCAP 21C8 CBR1 XCAP 20C3 CBR2 XCAP 20C3 CBR3 XCAP 21B7 CBR4 XCAP 21C5 CBR5 CAP-P 20B7 CBR6 CAPN 24B4 CBR7 CAPN 20B7 CBT1 CAPN 20C6 CBT2 CAPN 20C6 CBT3 CAPN 20D7 CBT4 CAPN 22A7 CBT5 CAPN 22A7 CBT6 CAPN 34B2 CBT7 CAPN 24B5 CBU2 CAPN 36B2 CBU1 CAPN 32B5 CBU2 CAPN 32A5 C7A1 CAPN 35A3 C7A2 CAPN 36C7 C7A3 CAPN 35A6 C7B1 CAPN 35A4 C7B2 CAP-P 35A6 C7B3 CAPN 33B5 C7B4 CAPN 33D6 C7B5 CAPPDFPN 33D3 C7B6 CAPN 35A4 C7B7 CAPN 35A5 C7C1 CAPN 33A6 C7C2 CAPN 29A1 C7C3 CAPN 29A2 C7C4 XCAP 49C4 C7C5 CAPN 29C2 C7C6 CAPN 29C3 C7D1 CAPN 33B6 C7D2 CAPN 33B4 C7D3 CAPN 33A6 C7E1 CAPN 33B6 C7E2 CAP-P 28C2 C7F1 CAP-P 28C3 C7G1 CAP-P 28D6 C7G2 CAP-P 34B5 C7G3 CAP-P 34B5 C7G4 CAPN 28D6 C7G5 CAPN 28D5	C6G5 CAPN 31C7 C6G6 CAPN 31C8 C6M1 CAPN 33A4 C6M2 CAPN 39D4 C6M3 CAPN 39B5 C6M4 CAPN 38B3 C6M5 CAPN 38B4 CBN1 XCAP 43B6 CBN2 CAPN 39B7 CBN3 XCAP 20C7 CBN4 XCAP 21C2 CBN5 XCAP 21C5 CBN6 XCAP 20C7 CBN7 XCAP 21A5 CBN8 CAPN 20A7 CBN9 XCAP 21D8 CBP1 XCAP 21D8 CBP2 XCAP 20D6 CBP3 XCAP 20C6 CBP4 XCAP 20D4 CBP5 XCAP 20C4 CBP6 CAPN 15A7 CBP7 XCAP 20D4 CBP8 CAPN 20A7 CBP9 XCAP 21B7 CBP10 XCAP 21C8 CBR1 XCAP 20C3 CBR2 XCAP 20C3 CBR3 XCAP 21B7 CBR4 XCAP 21C5 CBR5 CAP-P 20B7 CBR6 CAPN 24B4 CBR7 CAPN 20B7 CBT1 CAPN 20C6 CBT2 CAPN 20C6 CBT3 CAPN 20D7 CBT4 CAPN 22A7 CBT5 CAPN 22A7 CBT6 CAPN 34B2 CBT7 CAPN 24B5 CBU2 CAPN 36B2 CBU1 CAPN 32B5 CBU2 CAPN 32A5 C7A1 CAPN 35A3 C7A2 CAPN 36C7 C7A3 CAPN 35A6 C7B1 CAPN 35A4 C7B2 CAP-P 35A6 C7B3 CAPN 33B5 C7B4 CAPN 33D6 C7B5 CAPPDFPN 33D3 C7B6 CAPN 35A4 C7B7 CAPN 35A5 C7C1 CAPN 33A6 C7C2 CAPN 29A1 C7C3 CAPN 29A2 C7C4 XCAP 49C4 C7C5 CAPN 29C2 C7C6 CAPN 29C3 C7D1 CAPN 33B6 C7D2 CAPN 33B4 C7D3 CAPN 33A6 C7E1 CAPN 33B6 C7E2 CAP-P 28C2 C7F1 CAP-P 28C3 C7G1 CAP-P 28D6 C7G2 CAP-P 34B5 C7G3 CAP-P 34B5 C7G4 CAPN 28D6 C7G5 CAPN 28D5	C7G6 CAPPDFPN 33D4 C7G7 CAPN 33B4 C7M1 CAPN 36C7 C7N1 CAPN 29B8 C7N2 CAPN 29B7 C7P1 CAPN 29A4 C7P2 CAPN 29A2 C7P3 CAPN 29A3 C7P4 CAPN 29A3 C7P5 CAPN 29C3 C7P6 CAPN 29A2 C7P7 CAPN 29C3 C7P8 CAPN 29C3 C7P9 CAPN 33B6 C7P10 CAPN 29C4 C7R1 CAPN 33A4 C7R2 CAPN 33B5 C7R3 XCAP 23A3 C7R4 XCAP 24C4 C7T1 CAPN 23C8 C7T2 CAPN 29B2 C7T3 CAPN 29B1 CBA1 CAPN 33B4 CBA2 CAPN 33D5 CBA3 CAPN 49C3 CBA4 CAPN 33C6 CBA5 CAPN 49C1 CBB1 CAPN 36C6 CBB2 CAPN 35A4 CBB3 CAPN 35A5 CBB4 XCAP 35B5 CBB5 CAPN 35A3 CBB6 CAPN 37A7 CBC1 CAPN 37A3 CBC2 CAP-P 29A5 CBC3 CAPN 33C5 CBE1 CAPN 33D6 CBE2 CAPN 33B4 CBE3 CAPPDFPN 33D4 CBE4 CAPN 20A5 CBF1 CAPN 20B6 CBF2 CAPN 20B6 CBF3 CAPN 20B6 CBF4 CAPN 20C5 CBG1 CAPN 20D5 CBN1 CAPN 35A5 CBP1 CAPN 29A4 CBP2 CAPN 32C7 CBR1 CAPN 32A5 CR4M1 DIOSOT235 43B3 CR4M2 DIOSOT235 43C3 CR4M3 DIOSOT235 43A3 CR4M4 DIOSOT235 43C3 CR5G1 DIOSOT235 47D7 CR5G2 DIOSOT235 47A4 CR5G3 DIOSOT235 47A5 CR6M1 DIODE 40C6 CR6F1 DIODE 34C6 CR6U1 DIOSOT235 47C8 CR6U2 DIOSOT235 47B8 CR6U3 DIOSOT235 47A6 CR6U4 DIOSOT235 47A8 CR6V1 DIOSOT235 47B8 CR6V2 DIOSOT235 47A7 CR7A1 DIOSOT235 44C7 CR7F1 DIODE 34B5 CR7F2 DIODE 34C6 CR7G1 DIODE 34B6 DB3B1 X_DBPAD 31D5 DB3E1 X_DBPAD 26C1
--	---	--	--

DRAWING  
DVTFABP\_SCH 1 54  
Fri May 03 11:24:10 2002

INTEL CONFIDENTIAL	DOCUMENT NUMBER XXXXXX	PAGE 54	REV 12.0
-----------------------	---------------------------	------------	-------------

	8	7	6	5	4	3	2	1
D								
C	DBSF1 X_DBPAD 30C2 DBBF1 X_DBPAD 31B4 DBBF2 X_DBPAD 34C1 DBTF1 X_DBPAD 28C3 FB3B1 FERR_BD 43D5 FB3R1 FERRITE 12A1 FB4M1 FERR_BD 43D6 FB4N1 FERR_BD 41A3 FB5A1 FERR_BD 39D2 FB5A2 FERR_BD 39B2 FB6E1 FERRITE 23A6 FB7A1 FERRITE 40D8 FB7B2 FERRITE 35A6 FB8C1 FERRITE 29A5 FP2G1 LPAK4L 47C2 47D2 FPSG1 LPAK4L 47A2 47B2 J1G1 2X6HDR12 47D4 J2G1 2X10PWR 32D6 J2G2 2X5HDR10 49B3 J3A1 1X3HDR 49B5 J4G1 2X6HDR12 47B4 J5A1 24P_AV_BEC 44D4 J5A1 1X3HDR 48D3 J7D1 2X6HDR4 23A3 J8A1 2X7HDR14 49D2 J8C1 2X2HDR20 37B3 JA7A1 RJ45_2LED_TABUP 36A7 36B7 36D6 L1F1 INDUCTOR 26C2 L1R1 INDUCTOR 7D5 L3G1 INDUCTOR 26D5 L4A1 INDUCTOR 43A2 L4A2 INDUCTOR 43B2 L4A3 INDUCTOR 43C2 L4A4 INDUCTOR 43D2 L7F1 INDUCTOR 26C3 L7M1 INDUCTOR 36D7 L7N1 INDUCTOR 36D7 LBBD1 LABEL 45D7 MTG1B1 MTGCNR_2.7 45B6 MTG1E1 STD_MTG_EDGE 45B3 MTG1F1 STD_MTG_EDGE 45B2 MTG3A1 SLOT_X 49A5 MTG3G1 SLOT_X 49A4 MTG4B1 STD_MTG_HOLE 45A3 MTG4E1 STD_MTG_HOLE 45A5 MTG6F1 STD_MTG_HOLE 45B5 MTG7C1 STD_MTG_HOLE 45A4 MTG8A1 STD_MTG_HOLE 45B4 MTG8G1 STD_MTG_HOLE 45A6 Q1F1 FET_VREG 26C3 Q2U1 FET_VREG 26C3 Q2V1 PNP 49A1 Q3F1 NPN 23C3 Q3N1 BCP54 49A6 Q3V1 PNP 49B4 Q4M1 NPN 42B3 Q5A1 MBT3904DUAL 38A4 Q5A2 MMBT13LT1 41A3 Q5A3 PNP 38A5 Q5B1 MBT3904DUAL 49B3 Q5F1 MBT3904DUAL 16A6 Q5M1 NPN 40B6 Q5N1 NPN 40D5 Q5N2 FET 43A7 Q5N3 FET 12A3 Q6A1 PNP 44C7 Q6C1 MBT3904DUAL 14A6 Q6F1 FET 23A7 Q7A1 NPN 48C7 Q7A2 NPN 48C6	07B1 PNP 48B4 07E1 MBT3904DUAL 44B2 07F1 FET 34D2 07F2 FET 34C2 07F3 PNP 34C5 07F4 PNP 34C5 07G1 FET_VREG 26C4 07G2 NPN 34B7 07N1 NPN 43A7 07R1 MBT3904DUAL 25A7 08E1 PNP 26B6 08E2 NPN 26B7 08F1 FET_VREG 26B4 R1B1 RESN 10C3 R1B2 RESN 10C5 R1B3 RESN 10C5 R1C1 RESN 6C8 R1C2 RESN 6C7 R1C3 RESN 6C5 R1C4 RESN 7D5 R1C5 RESN 7C7 R1C6 RESN 6C5 R1C7 RESN 6C4 R1C9 RESN 7D7 R1C9 RESN 5C3 R1C10 RESN 6C4 R1C11 RESN 7D7 R1C12 RESN 5C3 R1C13 RESN 6C5 R1C14 RESN 5C4 R1C15 RESN 6C6 R1C16 RESN 6A2 R1C17 RESN 6C5 R1D1 RESN 7C7 R1D2 RESN 7B5 R1D3 RESN 7A6 R1D4 RESN 6B6 R1D5 RESN 6B1 R1D6 RESN 7C7 R1D7 RESN 6C6 R1D8 RESN 6B6 R1D9 RESN 7A6 R1D10 RESN 7A6 R1E1 RESN 26C2 R1F1 RESN 26C4 R1G1 RESN 47D7 R1P1 RESN 7D7 R1P2 RESN 5B4 R1R1 RESN 26B3 R1T1 GND_ISOLATION 26B1 R1T2 GND_ISOLATION 26A5 R1T3 GND_ISOLATION 26B2 R2B1 RESN 10C3 R2D1 RESN 6B5 R2D2 RESN 26A7 R2D3 RESN 26A7 R2D4 RESN 26B3 R2D5 RESN 26A7 R2E1 RESN 26D8 R2E2 RESN 26C6 R2E3 RESN 26C8 R2E4 RESN 26C8 R2E5 RESN 26B8 R2E6 RESN 26B8 R2E7 RESN 26B3 R2E8 RESN 26A4 R2E9 RESN 26B3 R2F1 RESN 47D2 R2G2 RESN 47D2 R2G3 RESN 47D1	R2G4 RESN 47D2 R2G5 RESN 47C2 R2G6 RESN 47C2 R2G7 RESN 47C1 R2G8 RESN 47C2 R2G9 RESN 47D7 R2G10 RESN 49A2 R2R1 RESN 26A7 R2T1 RESN 26D6 R2U1 RESN 26C2 R2U2 RESN 26C4 R3B1 RESN 49A7 R3B2 RESN 49A6 R3B3 RESN 49A6 R3B4 RESN 11C6 R3B5 RESN 31D7 R3B6 RESN 49A6 R3C1 RESN 49B5 R3D1 XRES 6B6 R3F1 RESN 23D4 R3F2 RESN 23C3 R3G1 RESN 49B2 R3G2 RESN 49A2 R3G3 RESN 49B2 R3G4 RESN 49B2 R3G5 RESN 49B4 R3P1 RESN 11A5 R3P2 RESN 11A5 R3P3 RESN 11C5 R3R1 XRES 6B6 R3R2 XRES 6B6 R3R3 RESN 11B5 R3U1 RESN 17A4 R3V1 RESN 49A2 R3V2 RESN 49B4 R3V3 RESN 49A4 R3V4 RESN 49A2 R4A1 RESN 49A7 R4A2 XRES 41C3 R4A3 XRES 41D2 R4A4 RESN 43B7 R4B1 RESN 43C8 R4B2 RESN 43B8 R4B3 RESN 43A5 R4B4 RESN 12B1 R4B5 RESN 12C1 R4B6 RESN 13C7 R4B7 RESN 41B2 R4B8 RESN 13C7 R4B9 RESN 13C7 R4F1 RESN 16A6 R4G3 RESN 47D7 R4G4 RESN 47D7 R4M1 RESN 43B2 R4M3 RESN 43D2 R4M4 RESN 43C2 R4M5 RESN 43A2 R4M6 XRES 42A3 R4M7 XRES 43C7 R4N1 XRES 41B7 R4N2 XRES 41C7 R4N3 XRES 41D3 R4N4 XRES 41D2 R4N5 RESN 43C7 R4N7 RESN 13B6 R4N8 RESN 13B6 R4N9 RESN 13C6 R4N10 RESN 13C6 R4N11 RESN 13B6 R4N12 RESN 13C6	R4N13 RESN 13B6 R4N14 XRES 43B7 R4R1 RESN 12A4 R4R2 XRES 12D4 R4R3 XRES 12D4 R4V1 RESN 47B7 R4V2 RESN 47C7 R5A1 RESN 39B4 R5A2 RESN 39B3 R5A3 RESN 39C4 R5A4 RESN 39D3 R5A5 XRES 41C2 R5A6 RESN 41B4 R5A7 RESN 39A3 R5A8 RESN 43A8 R5A9 RESN 38A4 R5A10 RESN 41A4 R5A11 RESN 38A5 R5A12 RESN 38A6 R5A13 RESN 43C5 R5B1 RESN 41C2 R5B2 RESN 49C3 R5B3 RESN 49B4 R5B4 RESN 49C4 R5B5 RESN 43B4 R5F1 RESN 16A3 R5F2 RESN 16A5 R5F3 RESN 16A3 R5F4 RESN 16A6 R5F5 RESN 16A6 R5G1 RESN 31B7 R5G2 RESN 47B2 R5G3 RESN 47B1 R5G4 RESN 47B1 R5G5 RESN 47B2 R5G6 RESN 47A1 R5G7 RESN 47A2 R5G8 RESN 47A1 R5G9 RESN 47A2 R5M1 RESN 44D6 R5M2 RESN 39D6 R5M3 RESN 40B3 R5M4 RESN 40B6 R5M5 RESN 40A7 R5M6 RESN 40A6 R5N1 RESN 40D5 R5N2 RESN 39A5 R5N3 RESN 40D5 R5N4 RESN 39A6 R5N5 RESN 40C8 R5N6 RESN 12A2 R5N7 RESN 12A1 R5P1 XRES 11C1 R5P2 XRES 11C1 R5R1 RESN 12B1 R5V1 RESN 47A7 R5V2 RESN 47A7 R6A1 RESN 48D6 R6A2 RESN 44B7 R6A3 RESN 44B6 R6A4 RESN 39D7 R6A5 RESN 25B2 R6A6 RESN 39D6 R6B1 RESN 39C5 R6B2 RESN 38C6 R6B3 RESN 39C6 R6B4 RESN 39B6 R6B5 RESN 39B5 R6B6 RESN 38C3 R6B7 RESN 38C3				
B								
A								
	8	7	6	5	4	3	2	1

DRAWING  
DVTFABP\_SCH 1:55  
Fri May 03 11:24:10 2002

INTEL CONFIDENTIAL	DOCUMENT NUMBER XXXXXX	PAGE 55	REV 12.0
-----------------------	---------------------------	------------	-------------

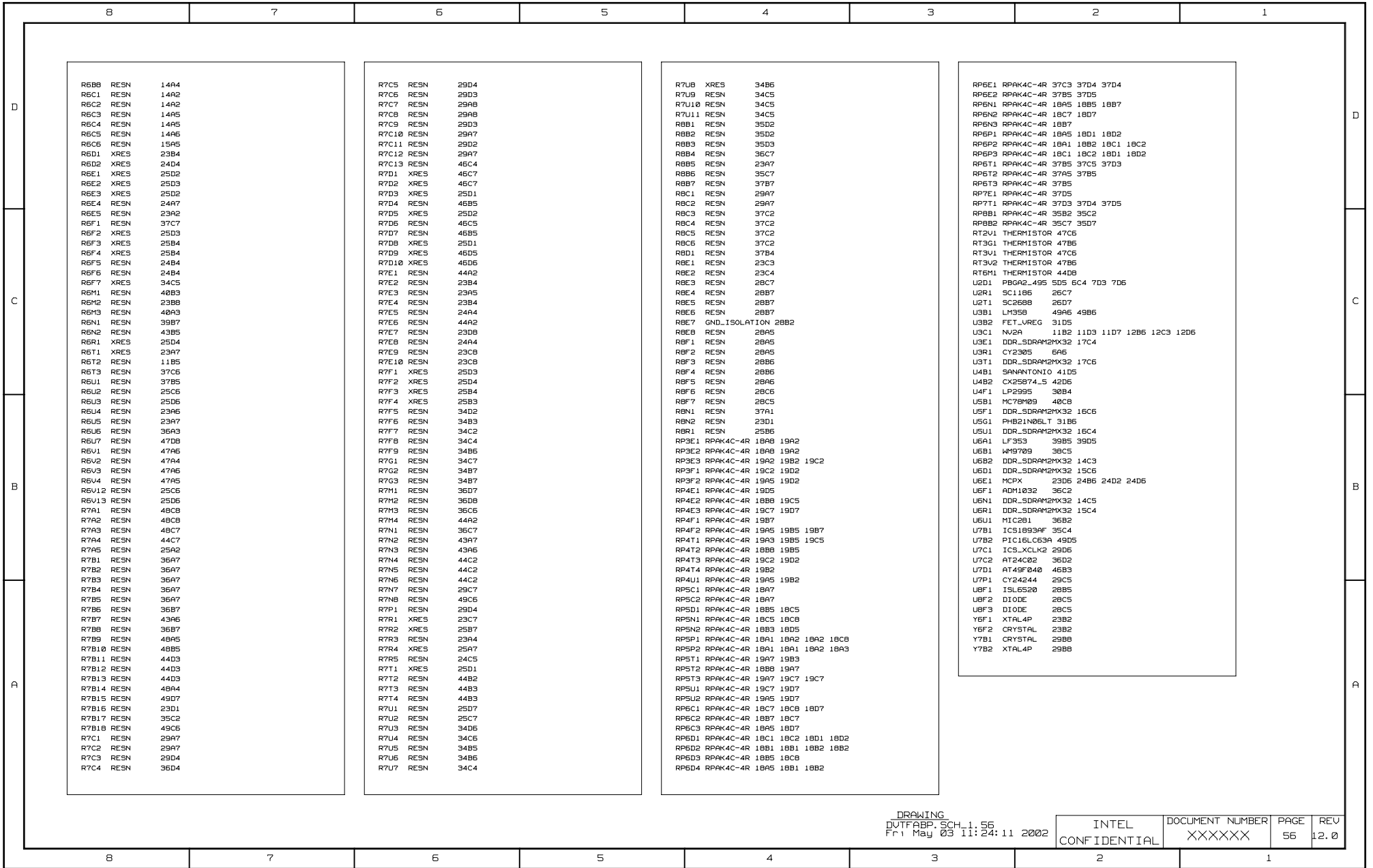

R6B8 RESN 14A4  
R6C1 RESN 14A2  
R6C2 RESN 14A2  
R6C3 RESN 14A5  
R6C4 RESN 14A5  
R6C5 RESN 14A6  
R6C6 RESN 15A5  
R6D1 XRES 23B4  
R6D2 XRES 24D4  
R6E1 XRES 25D2  
R6E2 XRES 25D3  
R6E3 XRES 25D2  
R6E4 RESN 24A7  
R6E5 RESN 23A2  
R6F1 RESN 37C7  
R6F2 XRES 25D3  
R6F3 XRES 25B4  
R6F4 XRES 25B4  
R6F5 RESN 24B4  
R6F6 RESN 24B4  
R6F7 XRES 34C5  
R6M1 RESN 40B3  
R6M2 RESN 23B8  
R6M3 RESN 40B3  
R6N1 RESN 39B7  
R6N2 RESN 43B5  
R6R1 XRES 25D4  
R6T1 XRES 23A7  
R6T2 RESN 11B5  
R6T3 RESN 37C6  
R6U1 RESN 37B5  
R6U2 RESN 25C6  
R6U3 RESN 25D6  
R6U4 RESN 23A6  
R6U5 RESN 23A7  
R6U6 RESN 36A3  
R6U7 RESN 47D8  
R6V1 RESN 47A6  
R6V2 RESN 47A4  
R6V3 RESN 47A6  
R6V4 RESN 47A5  
R6V12 RESN 25C6  
R6V13 RESN 25D6  
R7A1 RESN 48C8  
R7A2 RESN 48C8  
R7A3 RESN 48C7  
R7A4 RESN 44C7  
R7A5 RESN 25A2  
R7B1 RESN 36A7  
R7B2 RESN 36A7  
R7B3 RESN 36A7  
R7B4 RESN 36A7  
R7B5 RESN 36A7  
R7B6 RESN 36B7  
R7B7 RESN 43A6  
R7B8 RESN 36B7  
R7B9 RESN 48B5  
R7B10 RESN 48B5  
R7B11 RESN 44D3  
R7B12 RESN 44D3  
R7B13 RESN 44D3  
R7B14 RESN 48A4  
R7B15 RESN 49D7  
R7B16 RESN 23D1  
R7B17 RESN 35C2  
R7B18 RESN 49C6  
R7C1 RESN 29A7  
R7C2 RESN 29A7  
R7C3 RESN 29D4  
R7C4 RESN 36D4

R7C5 RESN 29D4  
R7C6 RESN 29D3  
R7C7 RESN 29A8  
R7C8 RESN 29A8  
R7C9 RESN 29D3  
R7C10 RESN 29A7  
R7C11 RESN 29D2  
R7C12 RESN 29A7  
R7C13 RESN 46C4  
R7D1 XRES 46C7  
R7D2 XRES 46C7  
R7D3 XRES 25D1  
R7D4 RESN 46B5  
R7D5 XRES 25D2  
R7D6 RESN 46C5  
R7D7 RESN 46B5  
R7D8 XRES 25D1  
R7D9 XRES 46D5  
R7D10 XRES 46D6  
R7E1 RESN 44A2  
R7E2 RESN 23B4  
R7E3 RESN 23A5  
R7E4 RESN 23B4  
R7E5 RESN 24A4  
R7E6 RESN 44A2  
R7E7 RESN 23D8  
R7E8 RESN 24A4  
R7E9 RESN 23C8  
R7E10 RESN 23C8  
R7F1 XRES 25D3  
R7F2 XRES 25D4  
R7F3 XRES 25B4  
R7F4 XRES 25B3  
R7F5 RESN 34D2  
R7F6 RESN 23A7  
R7F7 RESN 34C2  
R7F8 RESN 34C4  
R7F9 RESN 34B6  
R7G1 RESN 34C7  
R7G2 RESN 34B7  
R7G3 RESN 34B7  
R7M1 RESN 36D7  
R7M2 RESN 36D8  
R7M3 RESN 36C6  
R7M4 RESN 44A2  
R7M5 RESN 36C7  
R7M6 RESN 43A7  
R7M7 RESN 43A6  
R7N4 RESN 44C2  
R7N5 RESN 44C2  
R7N6 RESN 44C2  
R7N7 RESN 29C7  
R7N8 RESN 49C6  
R7P1 RESN 29D4  
R7R1 XRES 23C7  
R7R2 XRES 25B7  
R7R3 RESN 23A4  
R7R4 XRES 25A7  
R7R5 RESN 24C5  
R7T1 XRES 25D1  
R7T2 RESN 44B2  
R7T3 RESN 44B3  
R7T4 RESN 44B3  
R7U1 RESN 25D7  
R7U2 RESN 25C7  
R7U3 RESN 34D6  
R7U4 RESN 34C6  
R7U5 RESN 34B6  
R7U6 RESN 34B6  
R7U7 RESN 34C4

R7U8 XRES 34B6  
R7U9 RESN 34C5  
R7U10 RESN 34C5  
R7U11 RESN 34C5  
R8B1 RESN 35D2  
R8B2 RESN 35D2  
R8B3 RESN 35D3  
R8B4 RESN 36C7  
R8B5 RESN 23A7  
R8B6 RESN 35C7  
R8B7 RESN 37B7  
R8C1 RESN 29A7  
R8C2 RESN 29A7  
R8C3 RESN 37C2  
R8C4 RESN 37C2  
R8C5 RESN 37C2  
R8C6 RESN 37C2  
R8D1 RESN 37B4  
R8E1 RESN 23C3  
R8E2 RESN 23C4  
R8E3 RESN 28C7  
R8E4 RESN 28B7  
R8E5 RESN 28B7  
R8E6 RESN 28B7  
R8E7 GND\_ISOLATION 28B2  
R8E8 RESN 28A5  
R8F1 RESN 28A5  
R8F2 RESN 28A5  
R8F3 RESN 28B6  
R8F4 RESN 28B6  
R8F5 RESN 28A6  
R8F6 RESN 28C6  
R8F7 RESN 28C5  
R8N1 RESN 37A1  
R8N2 RESN 23D1  
R8R1 RESN 25B5  
RP3E1 RPAK4C-4R 18A8 19A2  
RP3E2 RPAK4C-4R 18A8 19A2  
RP3E3 RPAK4C-4R 19A2 19B2 19C2  
RP3F1 RPAK4C-4R 19C2 19D2  
RP3F2 RPAK4C-4R 19A5 19D2  
RP4E1 RPAK4C-4R 19D5  
RP4E2 RPAK4C-4R 18B8 19C5  
RP4E3 RPAK4C-4R 19C7 19D7  
RP4F1 RPAK4C-4R 18B7  
RP4F2 RPAK4C-4R 19A5 19B5 19B7  
RP4T1 RPAK4C-4R 19A3 19B5 19C5  
RP4T2 RPAK4C-4R 18B8 19B5  
RP4T3 RPAK4C-4R 19C2 19D2  
RP4T4 RPAK4C-4R 19B2  
RP4U1 RPAK4C-4R 19A5 19B2  
RPS1 RPAK4C-4R 18A7  
RPS2 RPAK4C-4R 18A7  
RPSD1 RPAK4C-4R 18B5 18C5  
RPSN1 RPAK4C-4R 18C5 18C8  
RPSN2 RPAK4C-4R 18B3 18D5  
RPS1 RPAK4C-4R 18A1 18A2 18A2 18C8  
RPS2 RPAK4C-4R 18A1 18A1 18A2 18A3  
RPS1 RPAK4C-4R 19A7 19B3  
RPS12 RPAK4C-4R 18B8 19A7  
RPS13 RPAK4C-4R 19A7 19C7 19C7  
RPSU1 RPAK4C-4R 19C7 19D7  
RPSU2 RPAK4C-4R 19A5 19D7  
RP6C1 RPAK4C-4R 18C7 18C8 18D7  
RP6C2 RPAK4C-4R 18B7 18C7  
RP6C3 RPAK4C-4R 18A5 18D7  
RP6D1 RPAK4C-4R 18A1 18C2 18D1 18D2  
RP6D2 RPAK4C-4R 18B1 18B1 18B2 18B2  
RP6D3 RPAK4C-4R 18B5 18C8  
RP6D4 RPAK4C-4R 18A5 18B1 18B2

RP6E1 RPAK4C-4R 37C3 37D4 37D4  
RP6E2 RPAK4C-4R 37B5 37D5  
RP6N1 RPAK4C-4R 18A5 18B5 18B7  
RP6N2 RPAK4C-4R 18C7 18D7  
RP6N3 RPAK4C-4R 18B7  
RP6P1 RPAK4C-4R 18A5 18D1 18D2  
RP6P2 RPAK4C-4R 18A1 18B2 18C1 18C2  
RP6P3 RPAK4C-4R 18C1 18C2 18D1 18D2  
RP6T1 RPAK4C-4R 37B5 37C5 37D3  
RP6T2 RPAK4C-4R 37A5 37B5  
RP6T3 RPAK4C-4R 37B5  
RP7E1 RPAK4C-4R 37D5  
RP7T1 RPAK4C-4R 37D3 37D4 37D5  
RP8B1 RPAK4C-4R 35B2 35C2  
RP8B2 RPAK4C-4R 35C7 35D7  
RT2V1 THERMISTOR 47C6  
RT3G1 THERMISTOR 47B6  
RT3V1 THERMISTOR 47C6  
RT3V2 THERMISTOR 47B6  
RT6M1 THERMISTOR 44D8  
U2D1 PBGA2\_495 5D5 6C4 7D3 7D6  
U2R1 SC1186 26C7  
U2T1 SC268B 26D7  
U3B1 LM358 49A6 49B6  
U3B2 FE1\_VREG 31D5  
U3C1 NV2A 11B2 11D3 11D7 12B6 12C3 12D6  
U3E1 DDR\_SDRAM2Mx32 17C4  
U3R1 CY2305 6A6  
U3T1 DDR\_SDRAM2Mx32 17C6  
U4B1 SANANTONIO 41D5  
U4B2 CX25874\_S 42D6  
U4F1 LP2995 30B4  
U5B1 MC78M09 40C8  
U5F1 DDR\_SDRAM2Mx32 16C6  
U5G1 PH821N06L1 31B6  
U5U1 DDR\_SDRAM2Mx32 16C4  
U6A1 LF353 39B5 39D5  
U6B1 M9709 38C5  
U6B2 DDR\_SDRAM2Mx32 14C3  
U6D1 DDR\_SDRAM2Mx32 15C6  
U6E1 MCPX 23D6 24B6 24D2 24D6  
U6F1 ADM1032 36C2  
U6N1 DDR\_SDRAM2Mx32 14C5  
U6R1 DDR\_SDRAM2Mx32 15C4  
U6U1 M1C2B1 36B2  
U7B1 ICS1893AF 35C4  
U7B2 PIC16LC63A 49D5  
U7C1 ICS\_XCLK2 29D6  
U7C2 AT24C02 36D2  
U7D1 AT49F040 46B3  
U7P1 CY24244 29C5  
U8F1 ISL6520 28B5  
U8F2 DIODE 28C5  
U8F3 DIODE 28C5  
Y6F1 XTAL4P 23B2  
Y6F2 CRYSTAL 23B2  
Y7B1 CRYSTAL 29B8  
Y7B2 XTAL4P 29B8