

# SEGA™ SERVICE MANUAL

## SEGA CD II /MEGA CD II

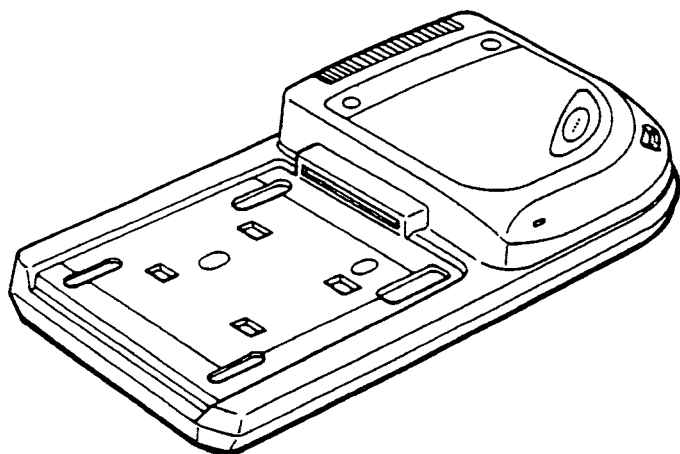

NO.	002
ISSUED	AUGUST, 1993

### CONTENTS

1. SPECIFICATIONS .....	2
2. IDENTIFYING PARTS .....	3
3. DISASSEMBLY .....	4
4. CD DRIVE ADJUSTMENT .....	6
5. CD INTERFACE .....	8
6. CD DRIVE UNIT REPLACEMENT PROCEDURE .....	9
7. TOC READ-IN FLOWCHART .....	10
8. GUIDES FOR SERVICING .....	11
9. BLOCK DIAGRAM .....	15
10. SCHEMATIC DIAGRAMS .....	16
11. CIRCUIT BOARD DIAGRAMS .....	18
12. PARTS SPECIFICATIONS .....	18
13. EXPLODED VIEW & PARTS LIST .....	38
13-1. Exploded View .....	38
13-2. Mechanical Parts List .....	39
13-3. Electrical Parts List .....	39
13-4. Accessories/Package List .....	42

**Sega Enterprises, Ltd.**

# 1. SPECIFICATIONS

## Ratings

Model	SEGA CD II	MEGA CD II
Power input	AC 120V, 60Hz	AC230 or 240V, 50Hz
Power consumption	18 W	18 W
Operating environment	Temperature : 0 to 40°C Humidity : 10% to 80%RH (no condensation)	
Dimensions	396 (W) × 220 (D) × 84 (H) mm	

## Specifications

CPU		68000 (12.5MHz)
Memory	RAM	6M bit (Program, Picture data, Sound data memory) 512k bit (PCM waveform memory) 128k bit (CD-ROM data cache memory) 64k bit (Back-up memory)
	Boot ROM	1M bit CD game BIOS CD player software CD+G compatible
Sound circuitry	PCM sound source	Stereo 8 channels. Sampling frequency 32kHz max.
	D/A converter	16 bit D/A converter. 8x internal over-sampling digital filter. PCM and CD sound mixing. Mixing with mixing terminal possible.
Audio characteristics	Frequency characteristics	20Hz to 20kHz
	Signal v. noise ratio (S/N)	Over 80dB (1kHz) (Line out)
	Dynamic range	Over 90dB
Battery back-up secondary duration		Approx. 1 month
CD drive unit	CD diameter	12cm and 8cm
	Rotational direction	Counter-clockwise (relative to the side opposite from the label)
	Access time	Average 1.5s
Audio output	Line out	RCA pin jack × 2 (L/R)
Audio input	Mixing	Stereo jack mixing.

\* Design and specifications are subject to change without notice.

## 2. IDENTIFYING PARTS

### 2-1. Front & Top View of Console

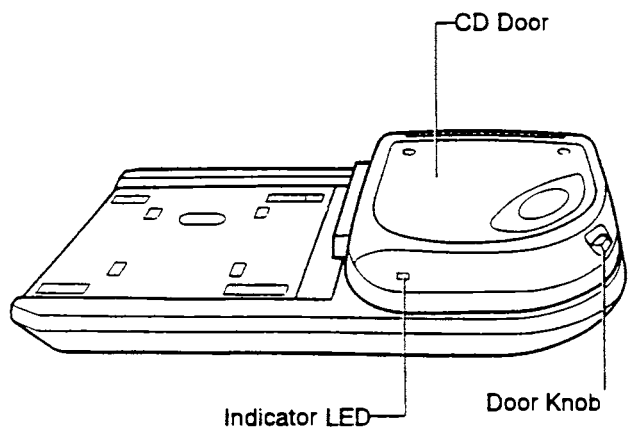

### 2-2. Back View of Console

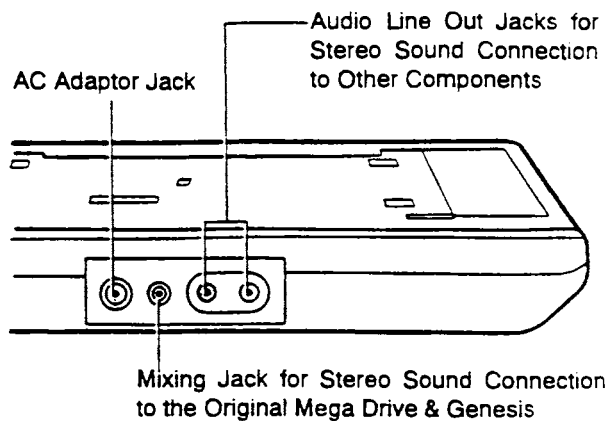

### 2-3. Accessories

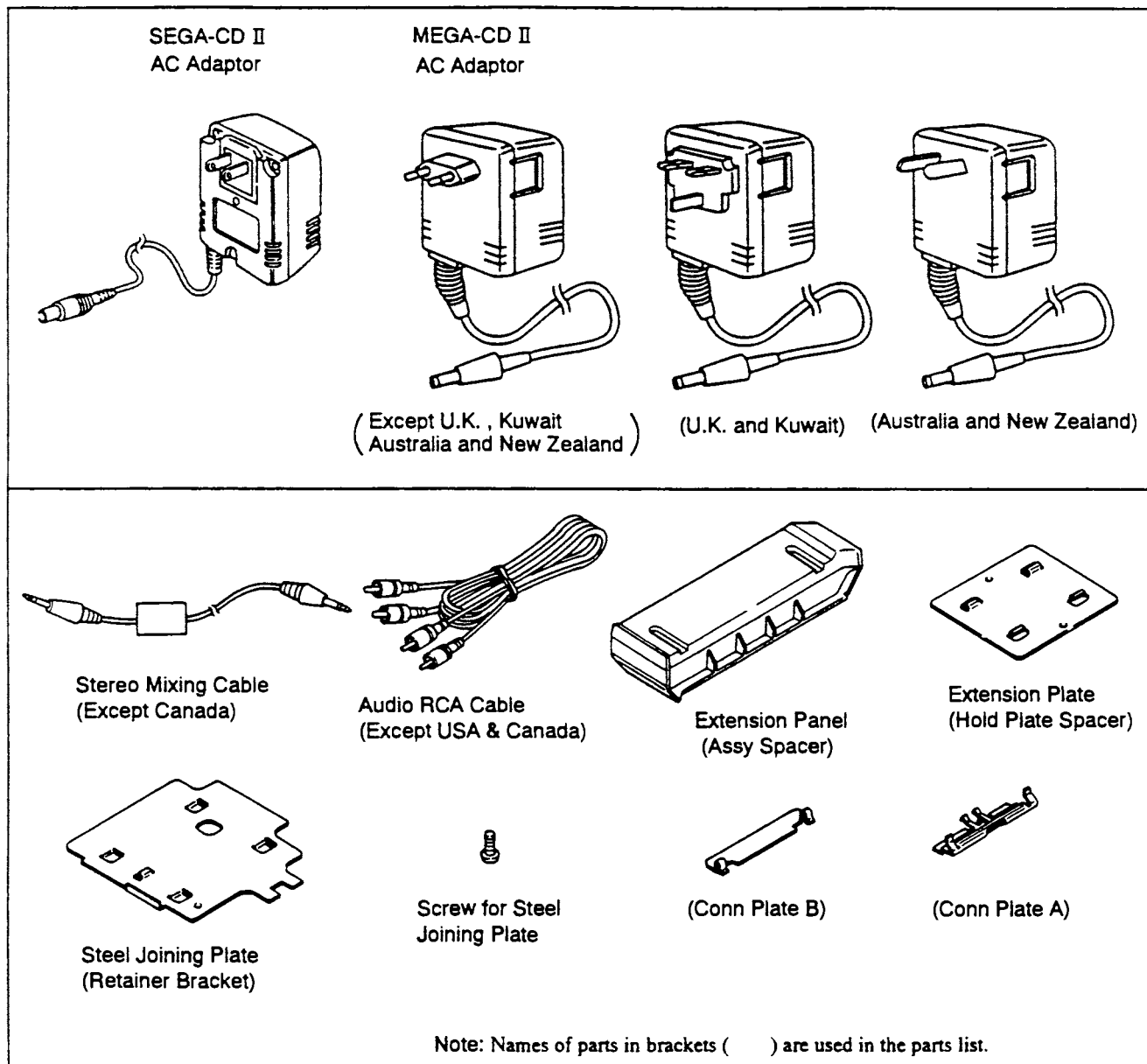

### 3. DISASSEMBLY

#### 3-1. Chuck Disk Assembly Removal

- (1) Press the door knob to open the door.
- (2) Release three (3) stoppers holding the chuck disk assembly.
- (3) When reinstalling, align the recesses in the chuck holder with the stoppers.

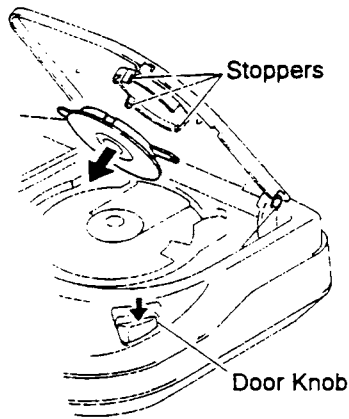

#### 3-3. Door Removal

- (1) Remove the top case assembly. (See item 3-2)
- (2) Press the door knob to open the door.
- (3) Remove the blind sheet on the right.
- (4) Remove the door spring.
- (5) Turn over the top case and remove two (2) screws, then remove the oil damper.
- (6) Push the door installation section in the directions of the arrows to release the bosses.

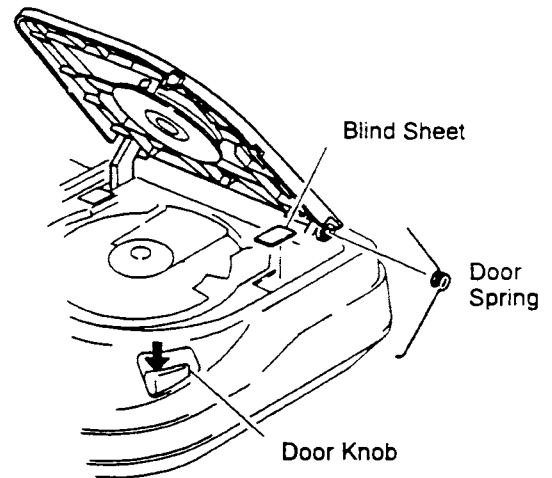

#### 3-2. Top Case Assembly Removal

- (1) Turn over the unit and remove six (6) screws from the bottom.
- (2) Do not remove the bottom case in this state. Be sure to turn over the unit again and then remove the top case in the original state.

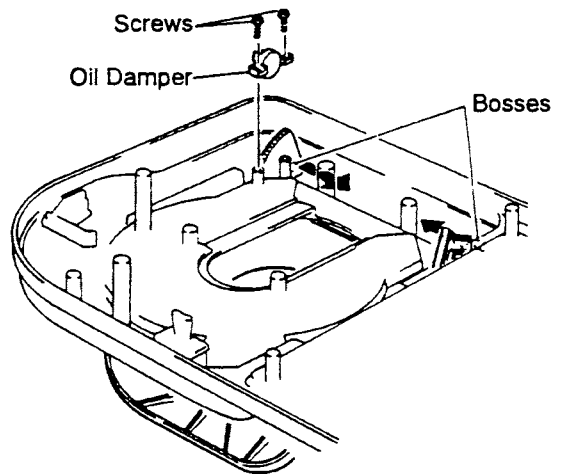
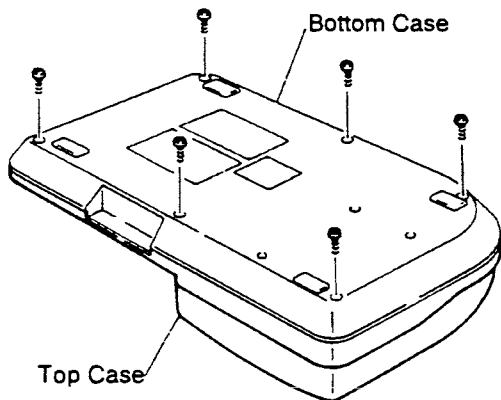



### 3-4. Dismantling the Chuck Disk Assembly

- (1) Remove the chuck disk assembly. (See item 3-1)
- (2) Remove the screw and release two (2) stoppers. The connector plate, magnet, chuck holder and chuck disk come apart on their own.

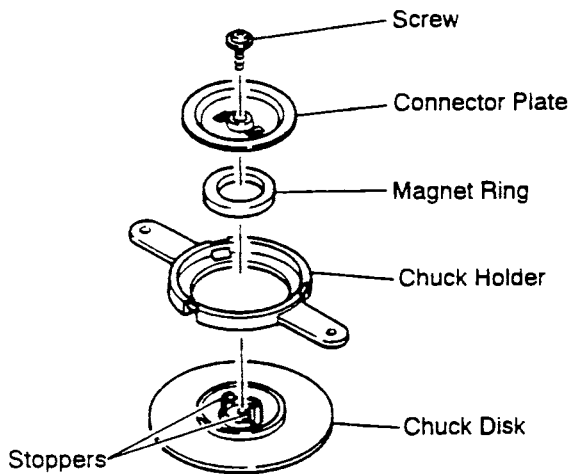

### 3-6. Circuit Board Assembly Removal

- (1) Remove the top case assembly. (See item 3-2)
- (2) Remove five (5) screws holding the shield plate.
- (3) Disconnect three (3) connectors from the CD drive unit.
- (4) Remove two (2) screws holding the circuit board assembly.

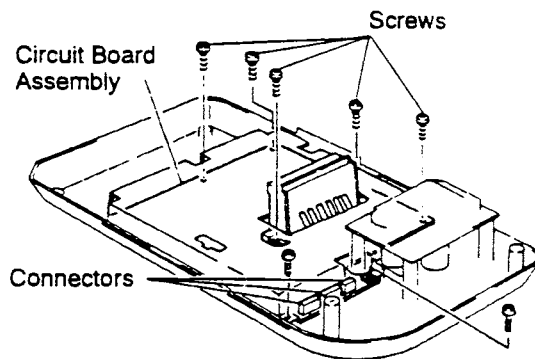

### 3-5. CD Drive Unit Removal

- (1) Remove the top case assembly. (See item 3-2)
- (2) Disconnect three (3) connectors and lift the CD drive unit.

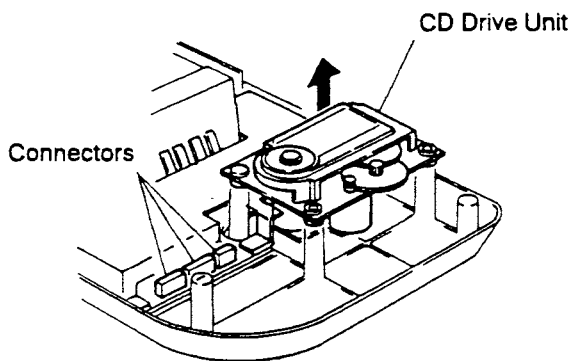

### 3-7. Door Lever and Door Knob Removal

- (1) Remove the top case assembly. (See item 3-2)
- (2) Turn over the top case assembly and release two (2) stoppers, then remove the door lever in the direction of the arrow.
- (3) Release two (2) stoppers and remove the door knob.

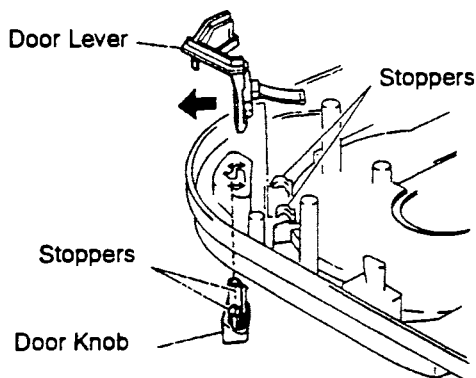

# 4. CD DRIVE ADJUSTMENT

## 4-1. Test Equipment and Test Disc

- 1) Frequency counter
- 2) Oscilloscope (20MHz or more)
- 3) Adjustment jig (MEGA-CD II (F) CD ADJ. JIG)
- 4) Audio generator
- 5) Voltmeter (two units with one needle or one unit with two needles)
- 6) Test CD (SONY TYPE-4)

## 4-2. Set-up for Adjustment

- 1) Connect both terminals of J401.
  - 2) Turn SW401 on and fix it using plastic tape, etc.
  - 3) Connect the jig to CN403.
  - 4) Supply power to the unit and jig. (Use AC adaptor of MEGA CD II /SEGA CD II for jig)
  - 5) Press the [RESET] switch of the jig so the counter reads "0".
  - 6) Connect the Q301's emitter and CN101 pin 28 B or connect Mega Drive II /Genesis II .
- 6) SNUBBER BE BETWEEN 3 AND 4*

Test mode	Adjustment item
0	VCO
2	EF balance
3	Tracking gain

Note 1: The test mode is incremented each time the [TEST] switch of the jig is pressed.

Note 2: Test mode 1 is for checking the laser power and keeps the pickup laser illuminated.

## 4-3. Adjustment Parts Location

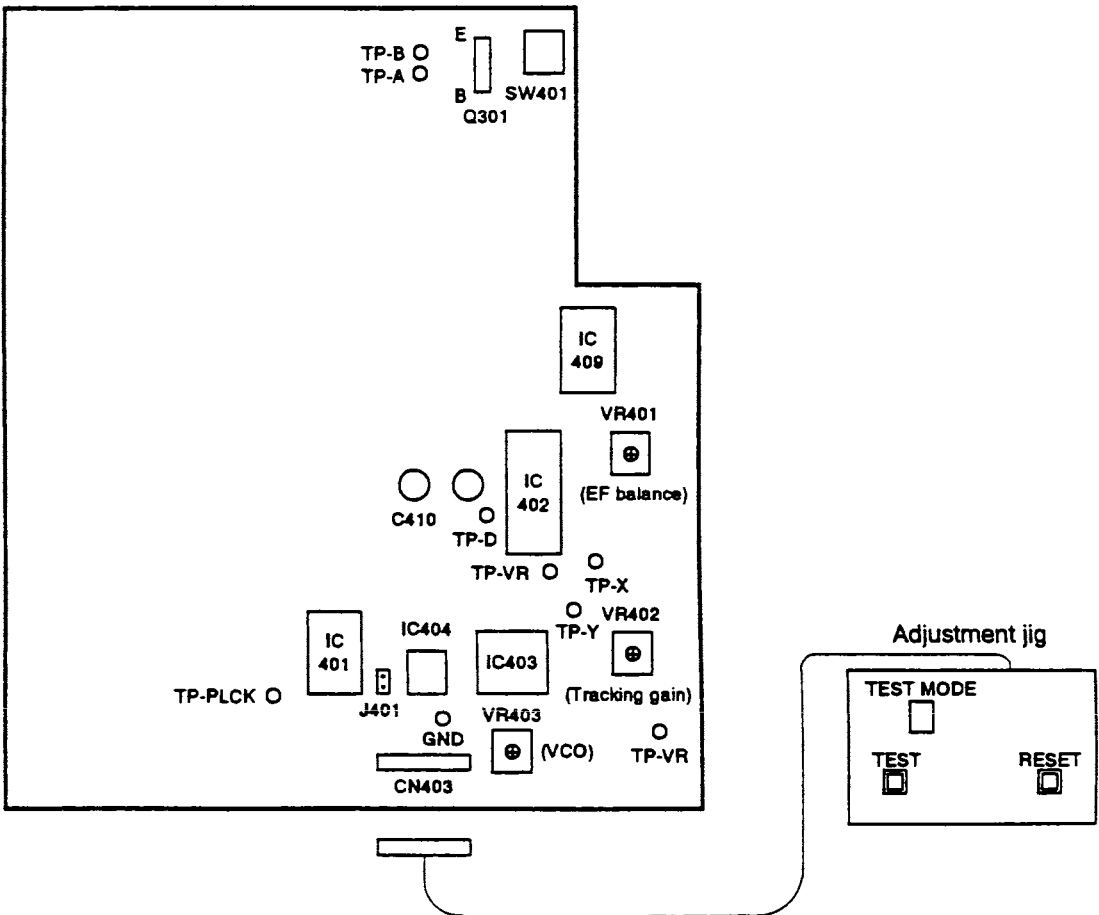

## 4-4. Adjustment

050/210 106

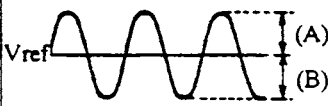
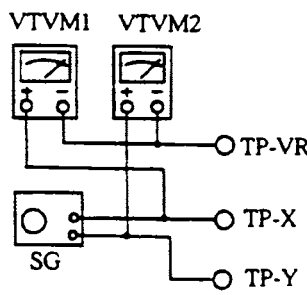
Adjustment name	Adjustment point	Test point	Test equipment	Adjustment procedure	Purpose	Faults due to incomplete adjustment
1. VCO adjustment	VR403	TP-PLCK (Connect the probe's ground to GND)	Frequency counter	Short both terminals of C410 or connect TP-D and GND. Adjust variable resistor VR403 so the frequency of the signal at test pin PLCK is $4.320 \pm 0.05\text{MHz}$ .	To reproduce a reference clock signal during CD play.	Small <ul style="list-style-type: none"> <li>• It takes more time to search for each track.</li> </ul>
						Large <ul style="list-style-type: none"> <li>• No play possible.</li> </ul>
2. EF balance adjustment	VR401	TP-X (Connect the probe's ground to TP-VR)	Oscilloscope, Adjustment jig. Probe: 10:1 50mv/div 1ms/div Test CD	Press [TEST] switch twice to set to "Test Mode 2".	To adjust the center of the tracking error signal	Small <ul style="list-style-type: none"> <li>• Playability of dirty discs and scratched discs becomes poor.</li> </ul>
				 <p>Adjust VR401 so that peaks (A) and (B) of the output waveform shown above are equal.</p>		
3. Tracking gain adjustment	VR402	TP-X TP-Y	2 voltmeters, Generator, Adjustment jig Test CD		To adjust the tracking servo gain.	Small <ul style="list-style-type: none"> <li>• Becomes susceptible to shocks.</li> <li>• It becomes impossible to search for each track on dirty and scratched discs.</li> </ul>
				<p>Connect as shown above. Press [TEST] switch three times to set to "Test Mode 3" and supply a 1.0kHz, 0.15Vrms signal from the generator. Adjust VR402 so the 2 voltmeters read the same value.</p>		Large <ul style="list-style-type: none"> <li>• Playability of dirty discs and scratched discs becomes poor.</li> </ul>

# 5. CD INTERFACE

## 5-1. CD Drive Block Diagram

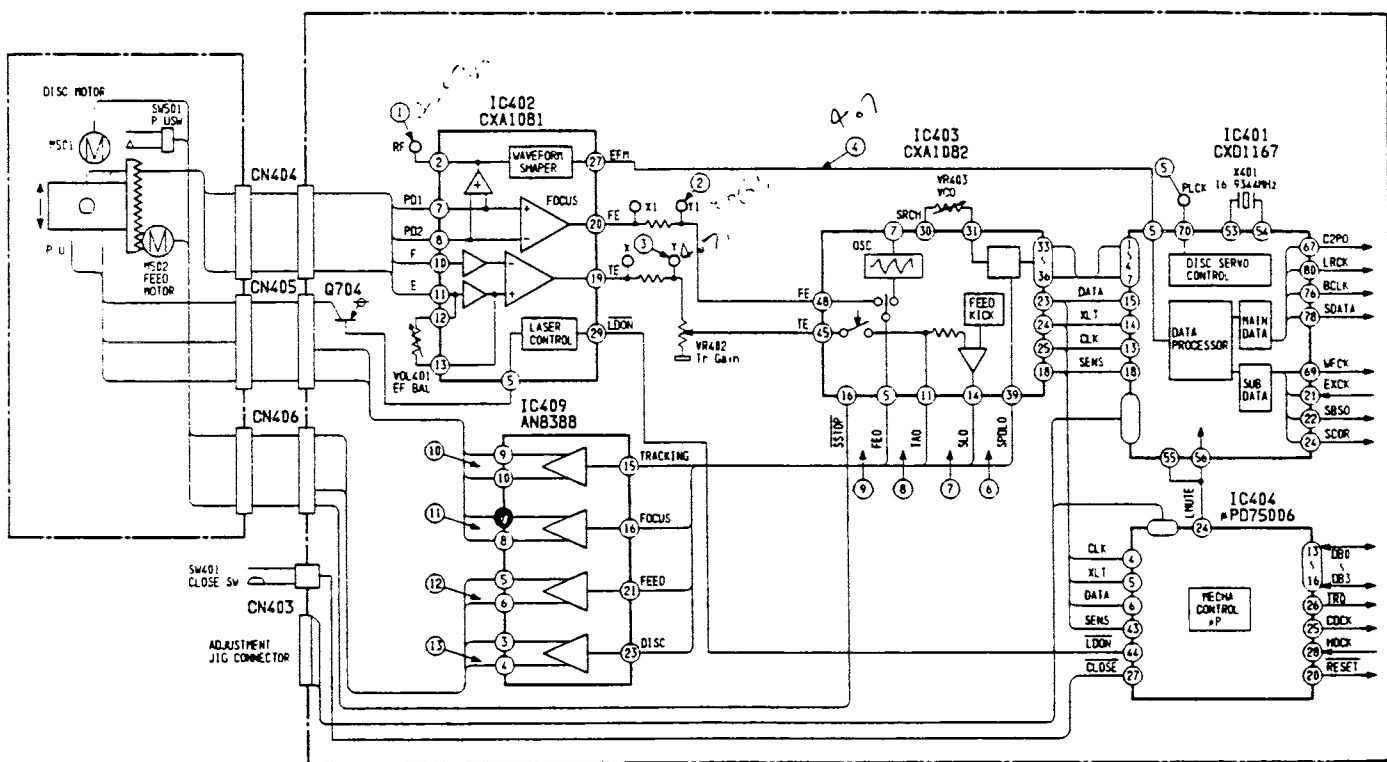
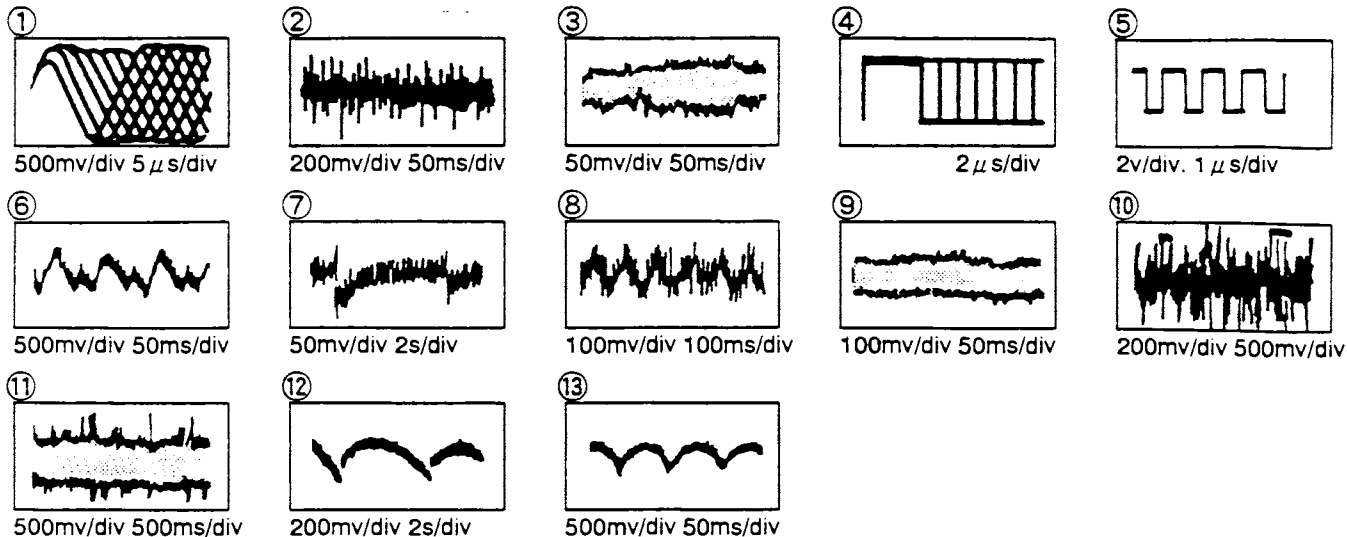

## 5-2. Description of CD Interface Signals

Name	I/O	Function	IC No.	Pin No.
C2PO	O	Error flag. Outputs "H" when data correction is disabled.	IC401	67
BCLK	O	Bit clock.	IC401	76
SDATA	O	Serial data output.	IC401	78
LRCK	O	L/R-channel identification clock.	IC401	80
16MHz	O	16.9344MHz output.	IC401	64
WFCK	O	Frame clock.	IC401	69
EXCK	I	Sub-code read clock.	IC401	21
SBSO	O	Sub-code data.	IC401	22
SCOR	O	Sub-code sync.	IC401	24
L-MUTE (DM)	O	Outputs "L" when playing back music and "H" in other modes.	IC404	24
IRQ	O	Interrupt request.	IC404	26
CDCK	O	CD mechanism control communications clock.	IC404	25
HOCK	I	Host communications clock.	IC404	29
DB 0	I/O	Data bus 0.	IC404	18
DB 1	I/O	Data bus 1.	IC404	19
DB 2	I/O	Data bus 2.	IC404	14
DB 3	I/O	Data bus 3.	IC404	13
RESET	I	Resets the CD hardware.	IC404	20

## 5-3. CD Interface Connection Reference Diagram

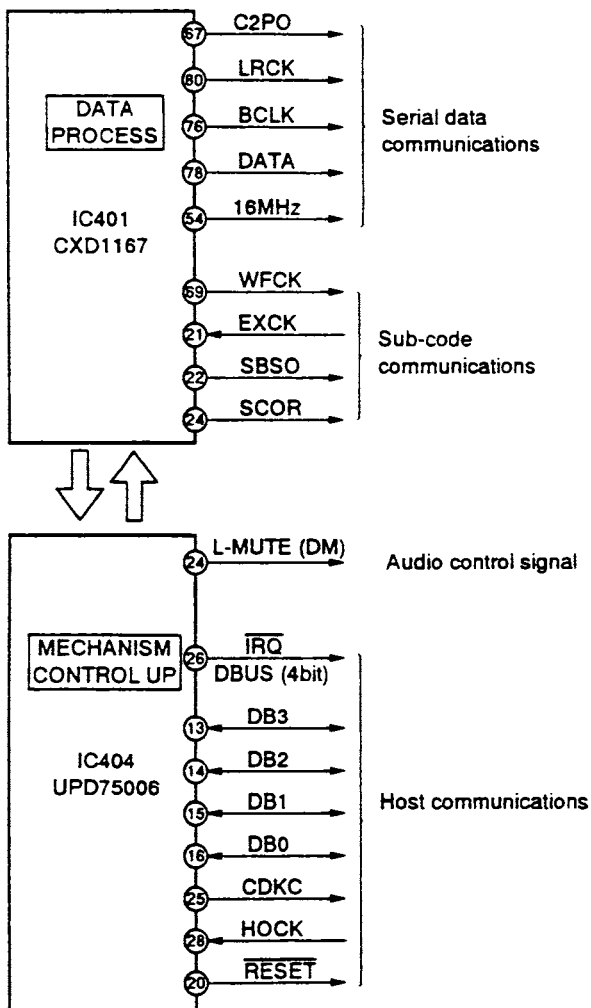

## 6. CD DRIVE UNIT REPLACEMENT PROCEDURE

Remove the GENESIS II/MEGA DRIVE II from the SEGA CD II/MEGA CD II and unplug the power cord of the SEGA CD II/MEGA CD II from the AC outlet.



Replace the CD drive unit.



Connect the power adapter and GENESIS II/MEGA DRIVE II.

Turn on the door close detection switch (SW401) forcibly to turn the power switch on. Check that the laser emits a beam for about 2 seconds and the pickup's object lens moves up and down.

**Caution:** Be careful; it is dangerous to look straight at a laser beam.

Do not bring your eyes too close to it.



Adjust the EF balance. (VR401)



Adjust the tracking gain. (VR402)



Check that an RF waveform of approx. 1.5Vp-p can be observed at IC402-2 (TP-RF).

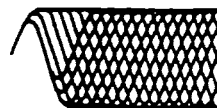

Replacement complete.

# 7. TOC (Total of Contents) READ-IN FLOWCHART

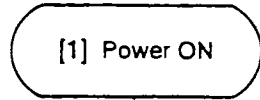

## Focus operation timing

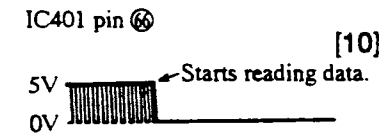
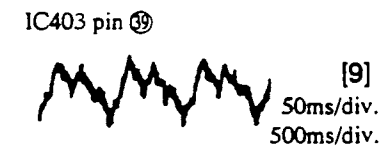
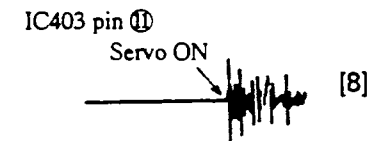
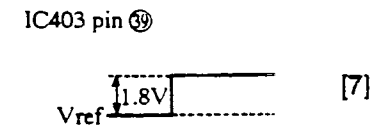
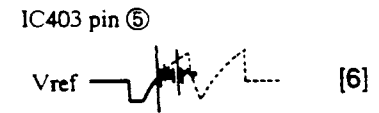
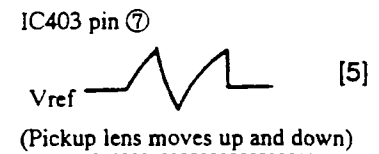
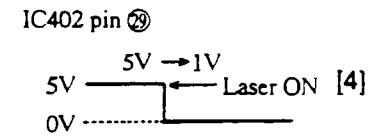
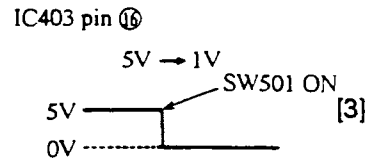
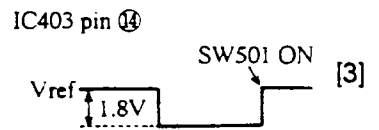
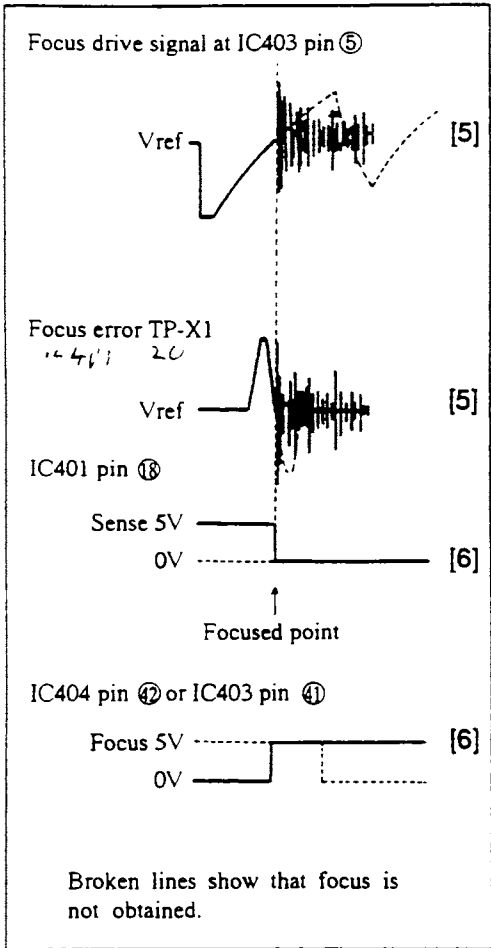

# 8. GUIDES FOR SERVICING

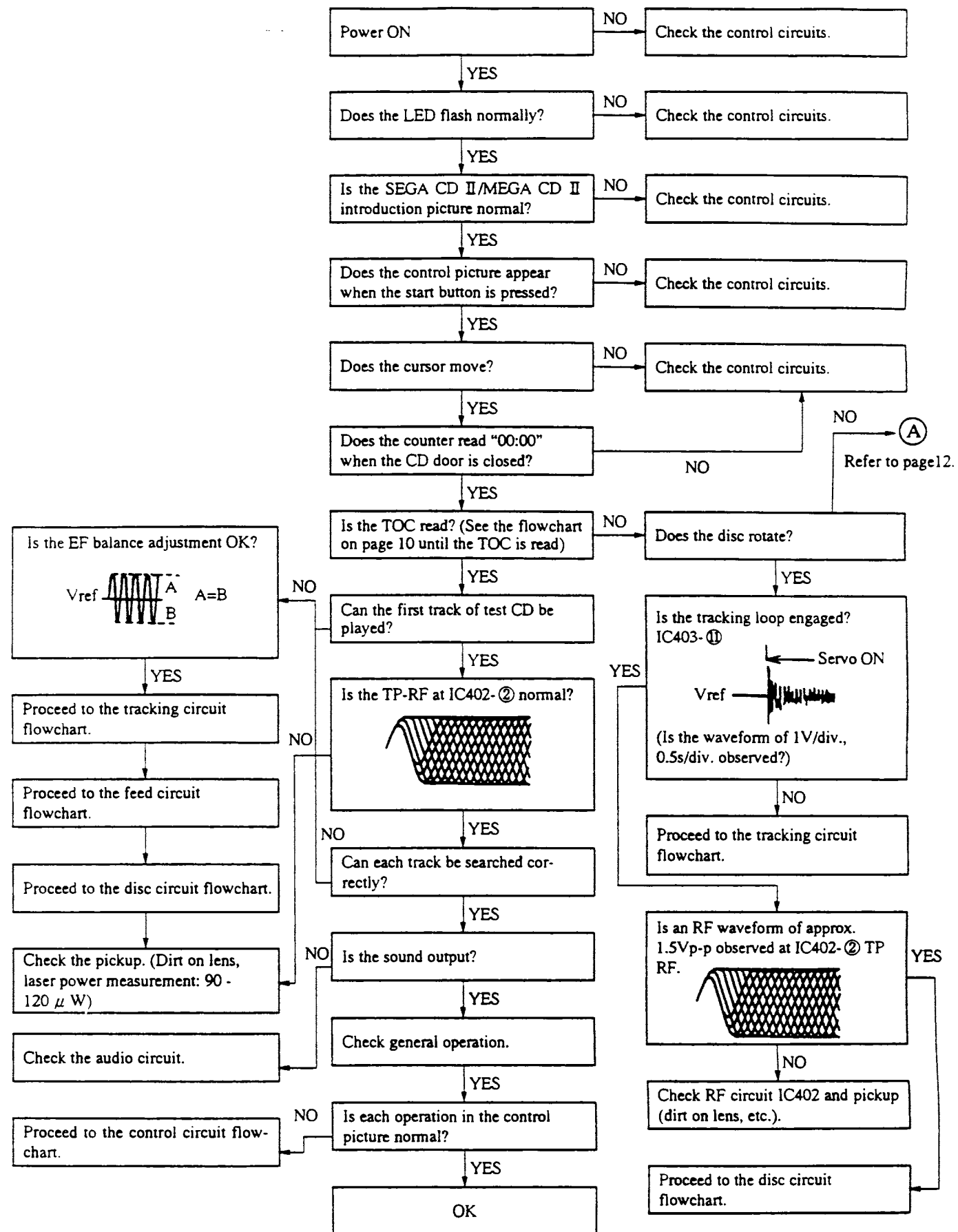

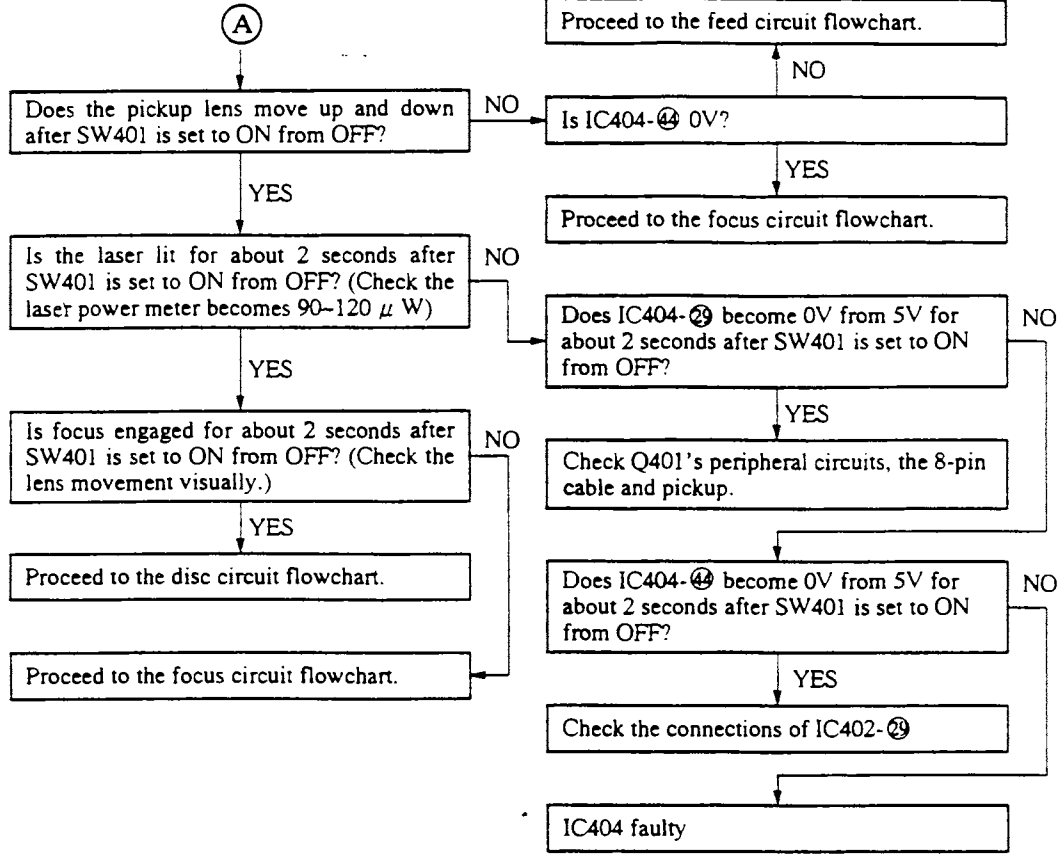

### 8-1. Focus Circuit Flowchart

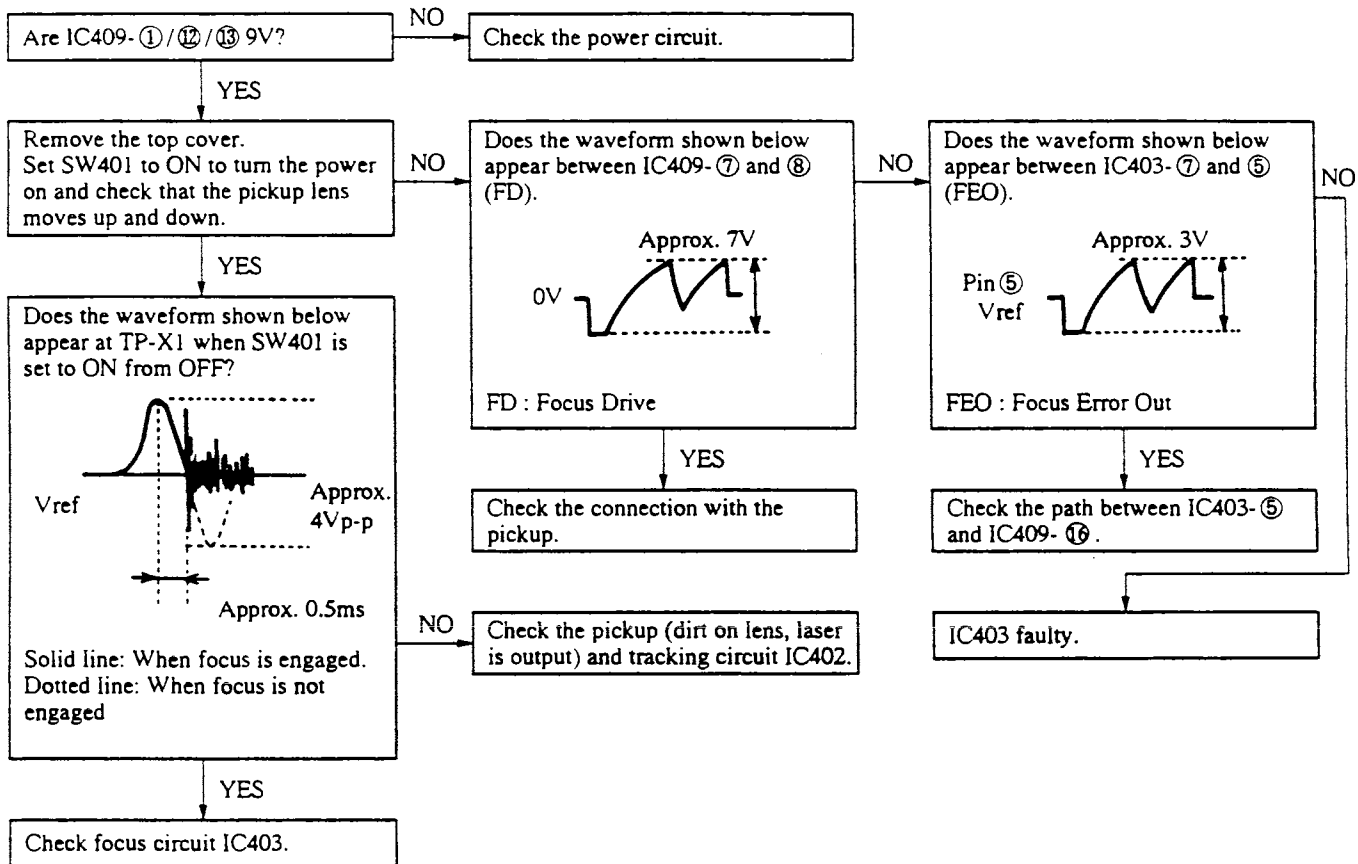



## 8-2. Tracking Circuit Flowchart

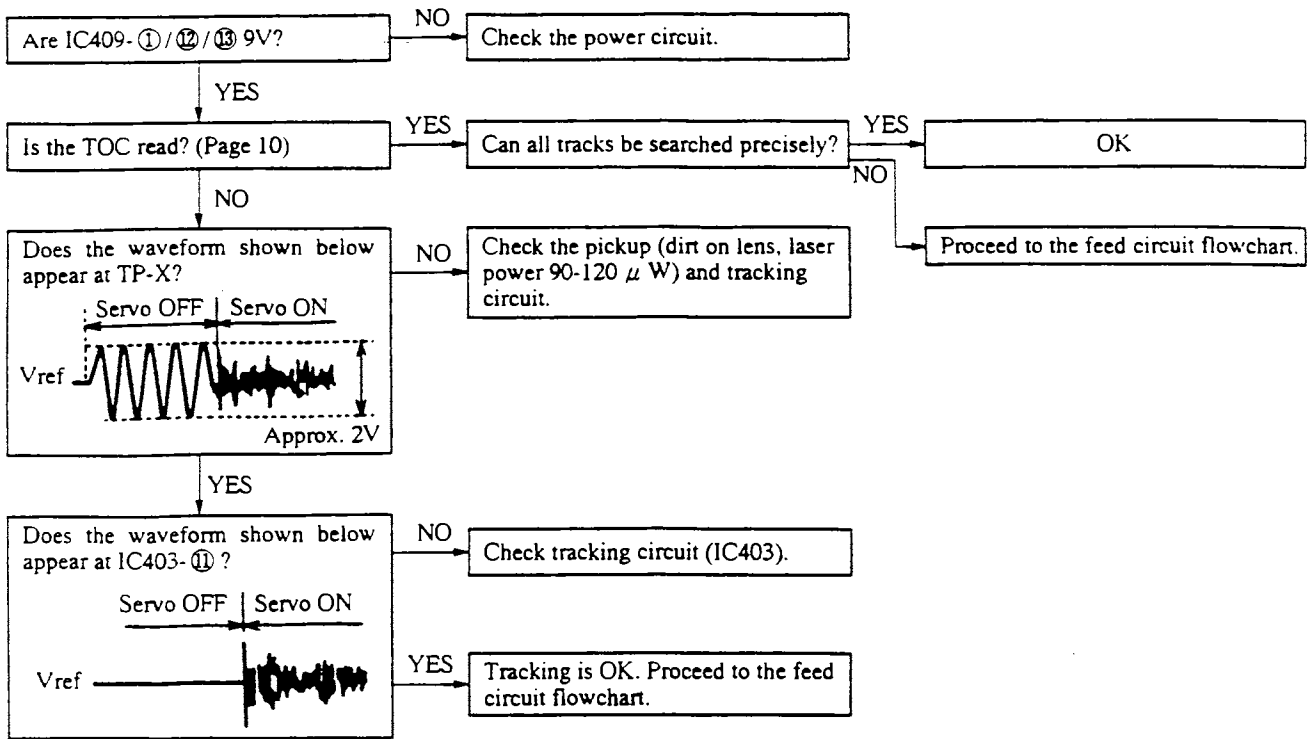

## 8-3. Disc Circuit Flowchart

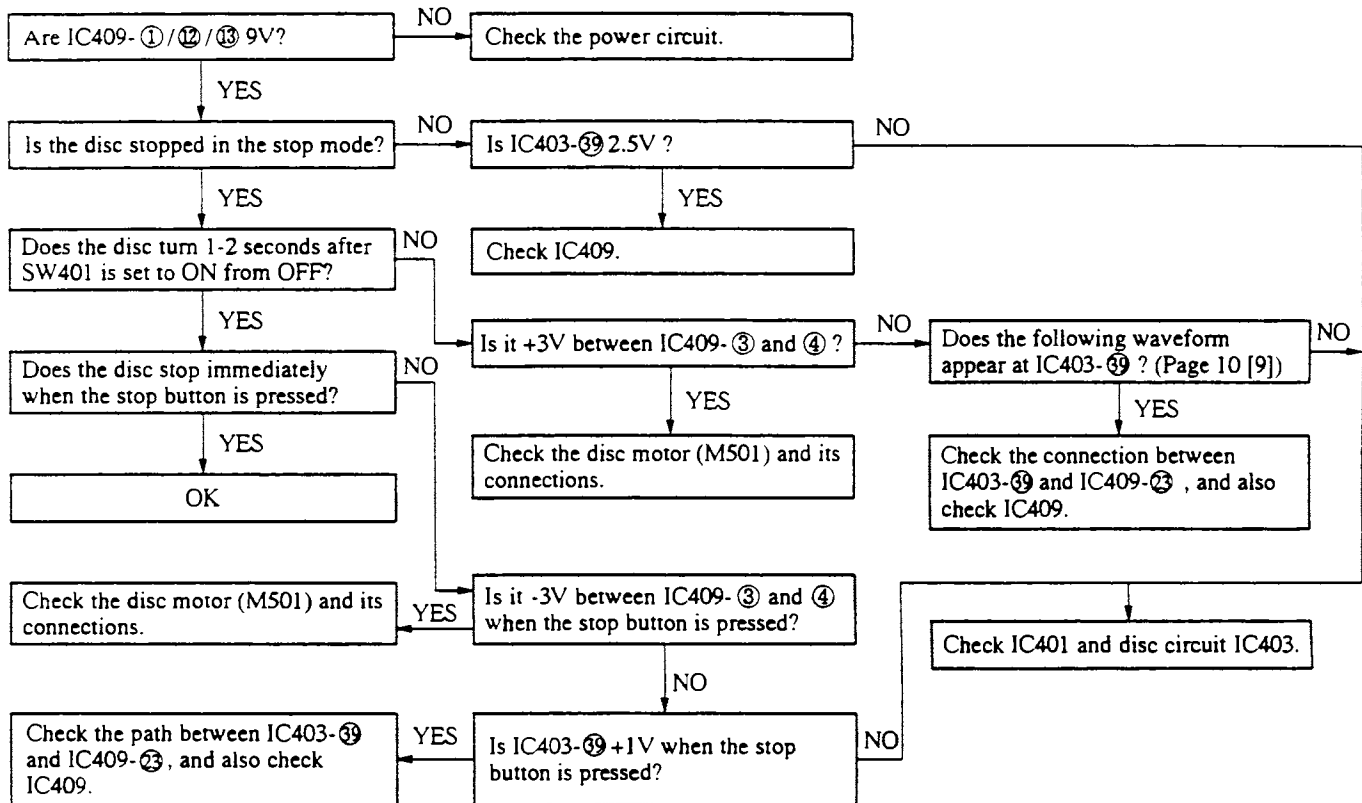

## 8-4. Feed Circuit Flowchart

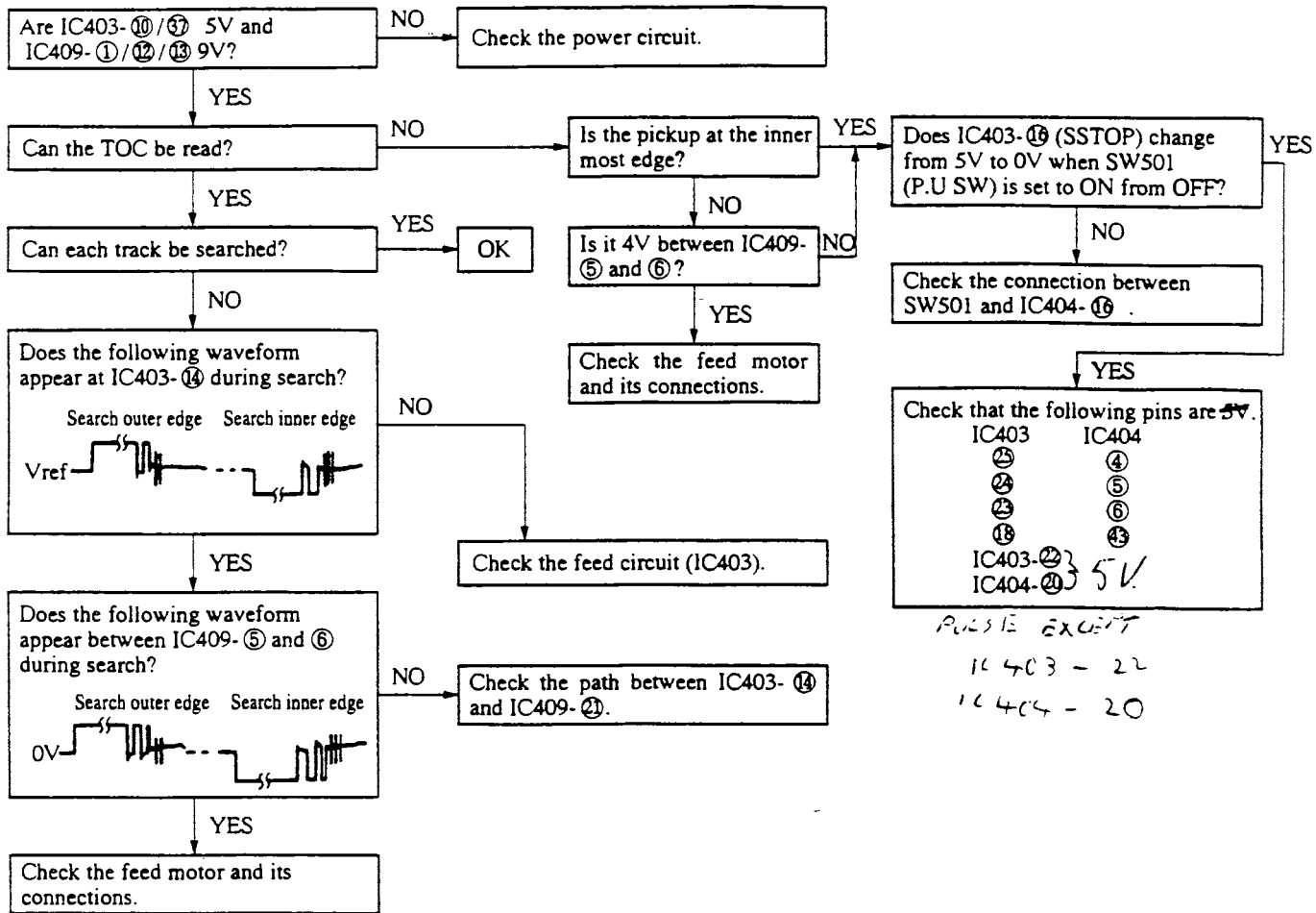

## FAULT LOG

CD Title screen frozen at start, no sound etc  
 → IC 401 faulty

→ Spins heaps - etc

→ IC 403

Sound from the CD driver distorted, but PCM sound OK

→ IC 401 faulty

# 9. BLOCK DIAGRAM

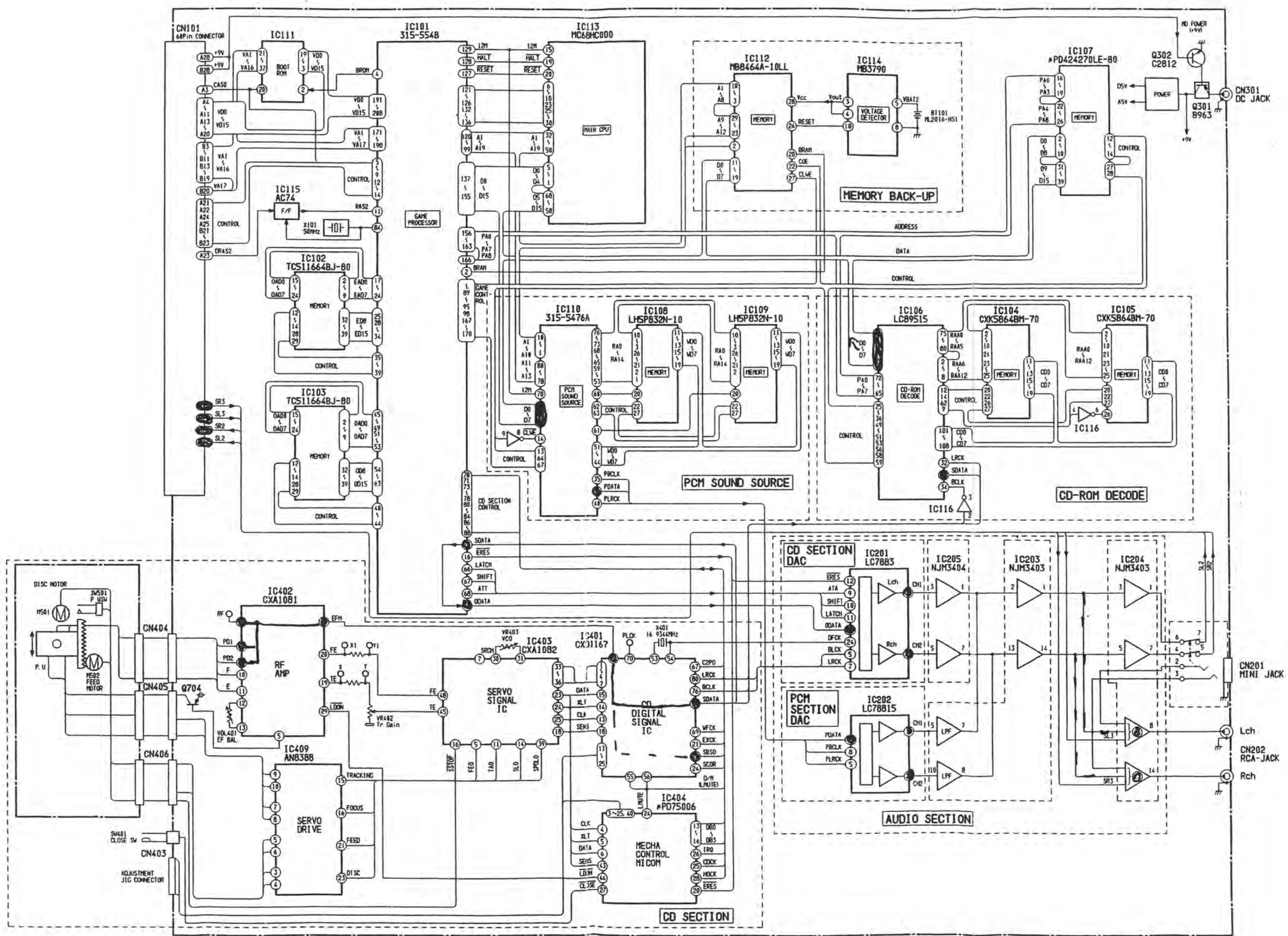

# 10. SCHEMATIC DIAGRAM

## 10-1. Schematic Diagram-1

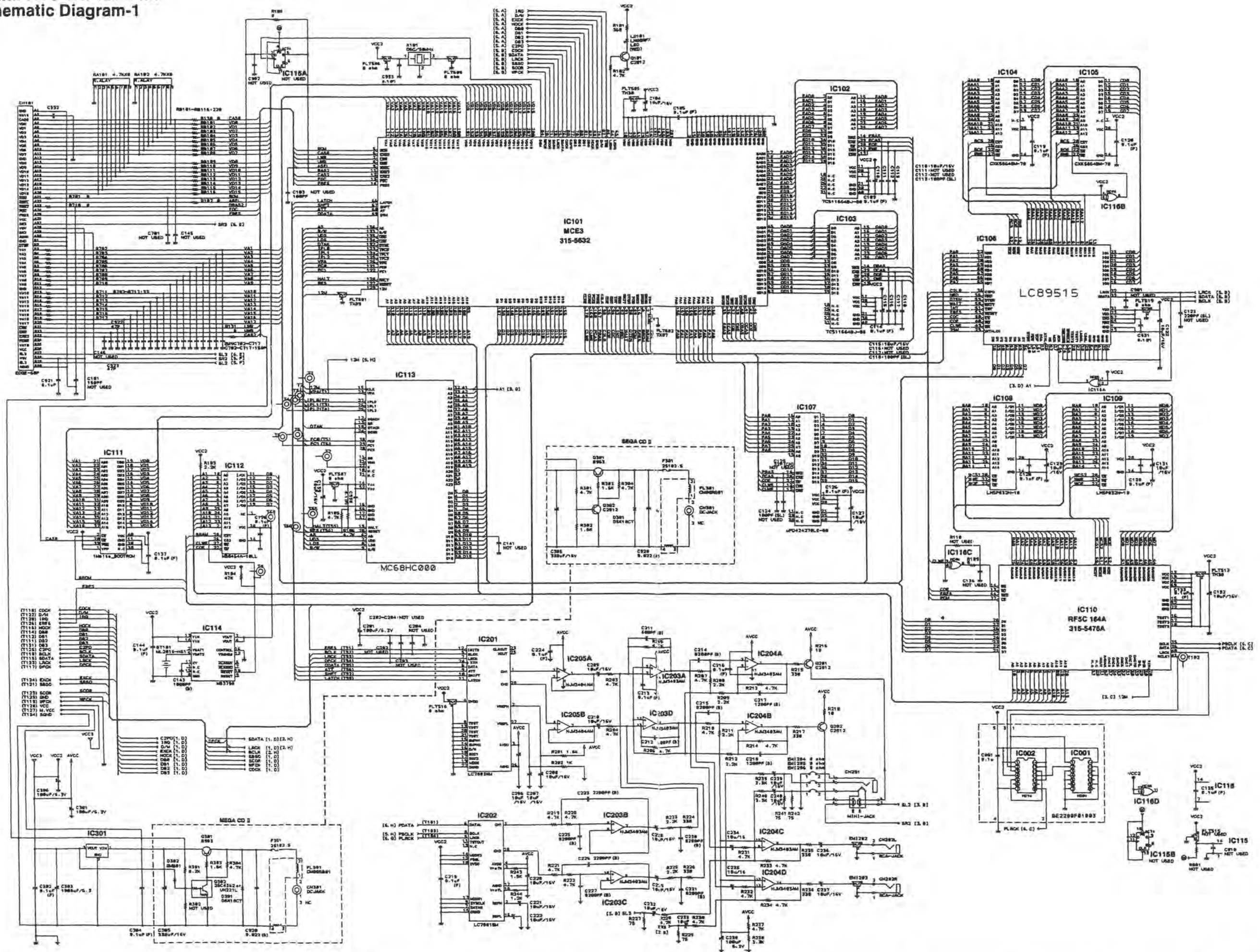



10-1. Schematic Diagram-2

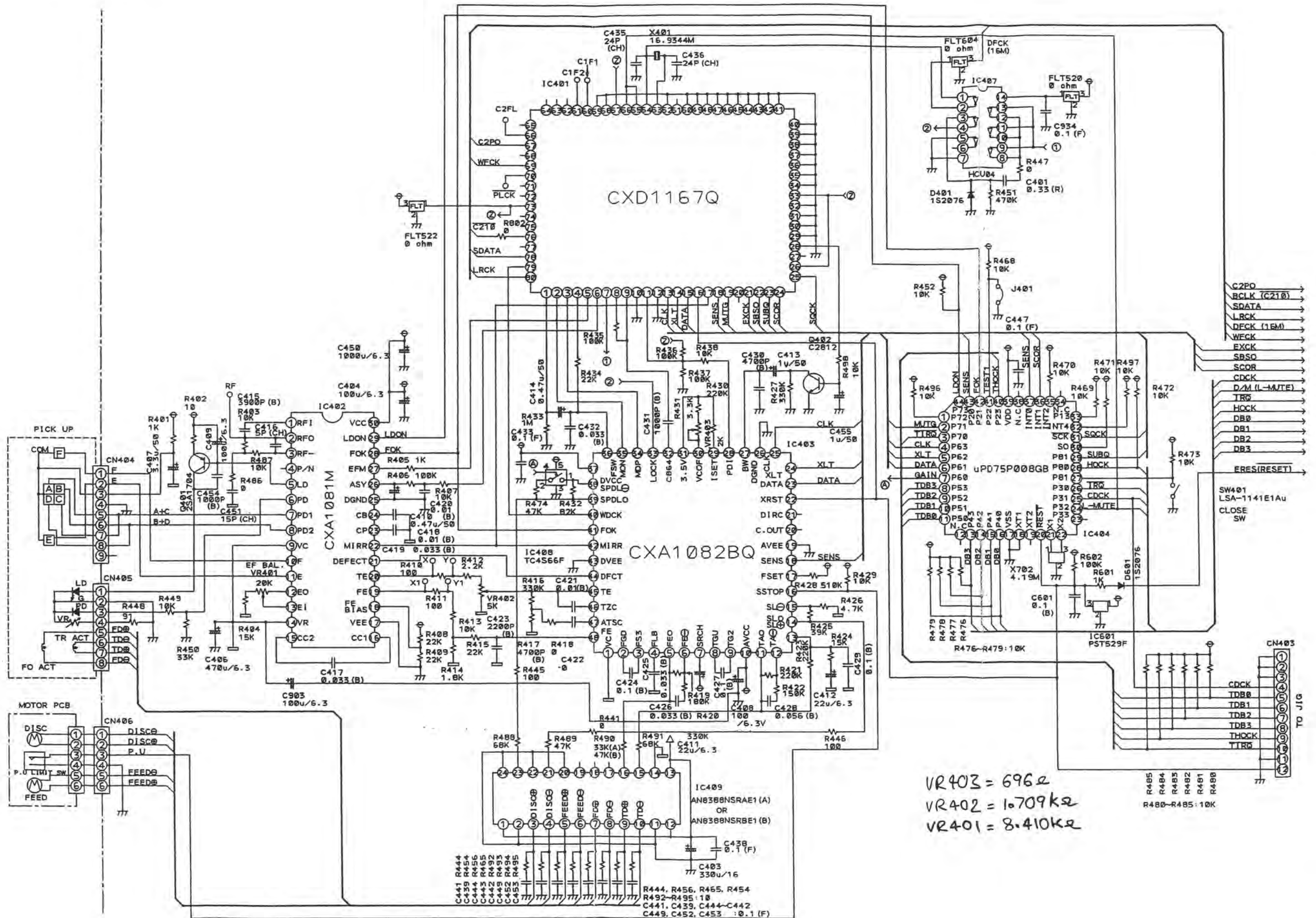





# IC101 CUSTOM CHIP

IC MCE3

Parts No. : 315-5632

## Top View

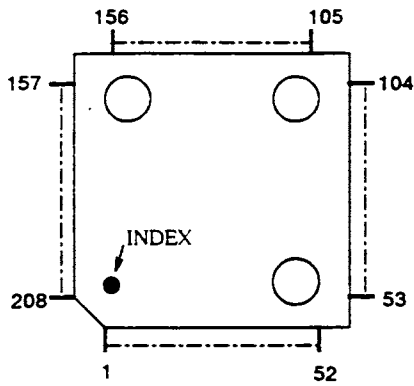

## Description

No.	I/O	Pin Name
1	O	OCK25
2	O	OBRAM
3	-	V <sub>SS</sub>
4	I	OXBROM
5	I	IROM
6	I	ICASO
7	I	ILWR
8	I	IUWR
9	I	IASEL
10	-	V <sub>DD</sub>
11	I	IRAS2
12	I	ICAS2
13	I	IFDC
14	I	IFRES
15	-	V <sub>SS</sub>
16	O	OERES
17	I/O	BEAD0
18	I/O	BEAD1
19	I/O	BEAD2
20	I/O	BEAD3
21	I/O	BEAD4
22	I/O	BEAD5
23	I/O	BEAD6
24	I/O	BEAD7
25	I/O	BED8
26	-	V <sub>SS</sub>
27	-	V <sub>DD</sub>
28	I/O	BED9
29	I/O	BED10
30	I/O	BED11
31	I/O	BED12
32	I/O	BED13
33	I/O	BED14
34	I/O	BED15
35	O	OERAS
36	O	OECAS
37	O	OEOE
38	-	V <sub>SS</sub>
39	O	OEWEE
40	O	OORAS
41	O	OOCAS
42	O	OOOE

No.	I/O	Pin Name
43	-	V <sub>DD</sub>
44	O	OOWE
45	I/O	BOAD0
46	I/O	BOAD1
47	I/O	BOAD2
48	I/O	BOAD3
49	I/O	BOAD4
50	-	V <sub>SS</sub>
51	I/O	BOAD5
52	I/O	BOAD6
53	I/O	BOAD7
54	I/O	BOD8
55	I/O	BOD9
56	I/O	BOD10
57	I/O	BOD11
58	I/O	BOD12
59	I/O	BOD13
60	-	V <sub>SS</sub>
61	-	V <sub>DD</sub>
62	I/O	BOD14
63	I/O	BOD15
64	O	OLEDR
65	O	OLEDG
66	O	OLATCH
67	O	OSHFT
68	O	OATT
69	O	ODTM
70	I	IWFCK
71	I	ISCOR
72	-	V <sub>SS</sub>
73	I	ISBSO
74	O	OEXCK
75	I	ILRCK
76	I	IDATA
77	I	IC2PO
78	I/O	BDB3
79	-	V <sub>DD</sub>
80	I/O	BDB2
81	I/O	BDB1
82	I/O	BDB0
83	O	OHOCK
84	I	ICK50

No.	I/O	Pin Name
85	-	V <sub>SS</sub>
86	I	IIRQ
87	I	IDXM
88	I	ICDCK
89	O	OXPCM
90	I	IDTEN
91	I	IWAIT
92	O	OHRD
93	I	IINT
94	O	OCDL
95	O	OPROE
96	-	V <sub>SS</sub>
97	-	V <sub>DD</sub>
98	O	OC2LR
99	I	IA19
100	I	IA18
101	I	IA17
102	I	IA16
103	I	IA15
104	I	IA14
105	I/O	BA13
106	I/O	BA12
107	-	V <sub>SS</sub>
108	I/O	BA11
109	I/O	BA10
110	I/O	BA9
111	I/O	BA8
112	I/O	BA7
113	I/O	BA6
114	-	V <sub>DD</sub>
115	I/O	BA5
116	I/O	BA4
117	I/O	BA3
118	I/O	BA2
119	-	V <sub>SS</sub>
120	I/O	BA1
121	I	IFC0
122	I	IFC1
123	O	OIPL0
124	O	OIPL1
125	O	OIPL2
126	O	OVPA
127	O	ORESET
128	O	OHALT
129	O	OCLK
130	-	V <sub>SS</sub>
131	-	V <sub>DD</sub>
132	O	ODTACK
133	I	IRXW
134	I	IXLDS
135	I	IXUDS
136	I	IXAS
137	I/O	BD0
138	I/O	BD1
139	I/O	BD2
140	I/O	BD3
141	I/O	BD4
142	-	V <sub>SS</sub>
143	I/O	BD5
144	I/O	BD6
145	I/O	BD7
146	I/O	BD8

No.	I/O	Pin Name
147	-	V <sub>DD</sub>
148	I/O	BD9
149	I/O	BD10
150	I/O	BD11
151	I/O	BD12
152	I/O	BD13
153	I/O	BD14
154	-	V <sub>SS</sub>
155	I/O	BD15
156	I/O	BPRA0
157	I/O	BPRA1
158	I/O	BPRA2
159	I/O	BPRA3
160	I/O	BPRA4
161	I/O	BPRA5
162	I/O	BPRA6
163	I/O	BPRA7
164	-	V <sub>SS</sub>
165	-	V <sub>DD</sub>
166	I/O	BPRA8
167	O	OPRRAS
168	O	OPRCAS
169	O	OPRUWE
170	O	OPRLWE
171	I/O	IVA1
172	I/O	IVA2
173	I/O	IVA3
174	I/O	IVA4
175	I/O	IVA5
176	-	V <sub>SS</sub>
177	I/O	IVA6
178	I/O	IVA7
179	I/O	IVA8
180	I/O	IVA9
181	I/O	IVA10
182	I/O	IVA11
183	-	V <sub>DD</sub>
184	I/O	IVA12
185	I/O	IVA13
186	I/O	IVA14
187	I/O	IVA15
188	I/O	IVA16
189	-	V <sub>SS</sub>
190	I	IVA17
191	I/O	BVD0
192	I/O	BVD1
193	I/O	BVD2
194	I/O	BVD3
195	I/O	BVD4
196	I/O	BVD5
197	I/O	BVD6
198	I/O	BVD7
199	I/O	BVD8
200	-	V <sub>SS</sub>
201	-	V <sub>DD</sub>
202	I/O	BVD9
203	I/O	BVD10
204	I/O	BVD11
205	I/O	BVD12
206	I/O	BVD13
207	I/O	BVD14
208	I/O	BVD15

# IC102/103 1Mbit Dynamic RAM

# IC104/105 8bit CMOS Static RAM

IC TC511664BJ-80  
IC UPD421664-80

IC TC421664LE-70  
IC UPD421664-80L

IC CKX5864BM-70  
IC MB8464-90

IC MB8464-80

## Top View & Pin Layout

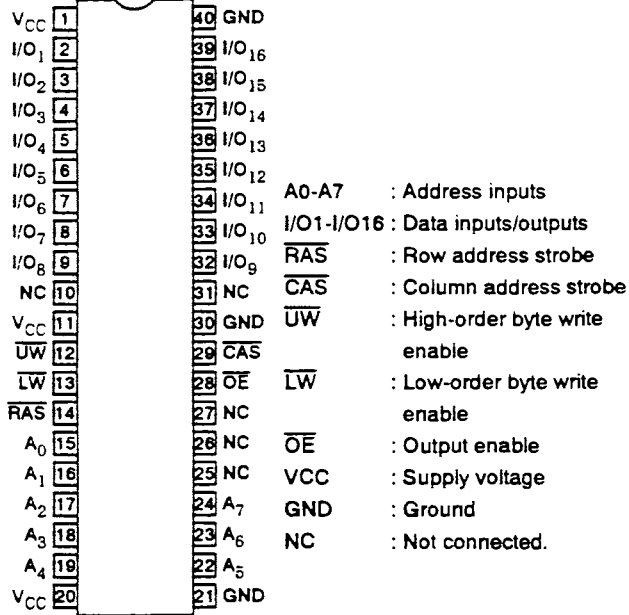

## Top View & Pin Layout

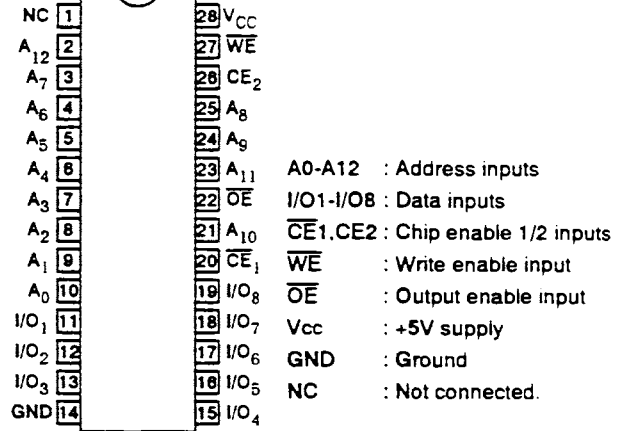

# IC106 CD-ROM LSI

IC LC89515

## Top View

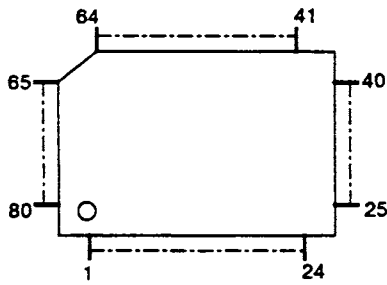

## Description

No.	I/O	Pin Name	No.	I/O	Pin Name	No.	I/O	Pin Name	No.	I/O	Pin Name
1	-	V <sub>SS</sub>	21	I/O	IO3	41	-	V <sub>SS</sub>	61	O	EOP
2	O	RA6	22	I/O	IO2	42	I/O	D3	62	O	RCS
3	O	RA7	23	I/O	IO1	43	I/O	D4	63	O	HDE
4	O	RA8	24	-	V <sub>SS</sub>	44	I/O	D5	64	-	V <sub>SS</sub>
5	O	RA9	25	I	EXTAL	45	I/O	D6	65	I/O	HD7
6	O	RA10	26	O	XTAL	46	I/O	D7	66	I/O	HD6
7	O	RA11	27	I	TEST A	47	I	RS	67	I/O	HD5
8	O	RA12	28	I	TEST B	48	I	RD	68	I/O	HD4
9	O	RA13	29	I	CSEL	49	I	WR	69	I/O	HD3
10	O	RA14	30	I	LMSEL	50	I	CS	70	I/O	HD2
11	O	RA15	31	-	V <sub>DD</sub>	51	O	INT	71	I/O	HD1
12	O	RWE	32	I	LRCK	52	-	V <sub>SS</sub>	72	I/O	HD0
13	-	V <sub>SS</sub>	33	I	SDATA	53	I	RESET	73	-	V <sub>DD</sub>
14	O	ROE	34	I	BCK	54	I	ENABLE	74	I	SELDRO
15	I/O	ERA	35	I	C4LR	55	I	HRW	75	O	RA0
16	I/O	IO8	36	I	C2PO	56	I	HRD	76	O	RA1
17	I/O	IO7	37	O	MCK	57	I	CMD	77	O	RA2
18	I/O	IO6	38	I/O	D0	58	O	WAIT	78	O	RA3
19	I/O	IO5	39	I/O	D1	59	O	DTEN	79	O	RA4
20	I/O	IO4	40	I/O	D2	60	O	STEN	80	O	RA5



# IC107 CMOS Dynamic RAM

IC UPD424270LE-80

IC HM514270AJ-8

IC M5M44270AJ-8

IC MN414270SJ-08

## Top View & Pin Layout

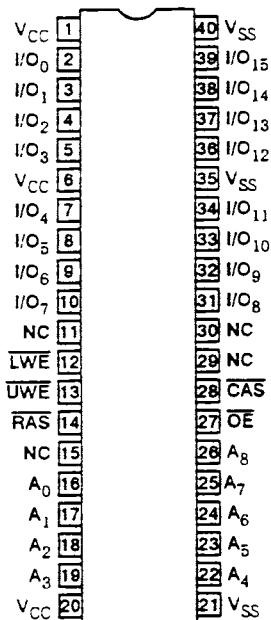

Input State				Output State	Operation Mode
RAS	CAS	UWE	LWE		
H	H	D	D	Open	Standby
H	L	H	H	Valid	Standby
L	L	H	H	Valid	Read cycle
L	L	L 2)	L 2)	Open	Early write cycle
L	L	L 2)	L 2)	Underlined	Delayed write cycle
L	L	H→L	H→L	Valid	Read modified write cycle
L	H	D	D	Open	RAS only refresh cycle
H→L	L	D	D	Open	CAS before /RAS refresh cycle
L	H→L	H	H	Valid	High-speed page mode read cycle
L	H→L	L 2)	L 2)	Open	High-speed page mode early write cycle
L	H→L	L 2)	L 2)	Underlined	High-speed page mode delayed write cycle
L	H→L	H→L	H→L	Valid	High-speed page mode read modified write cycle

Note: H=High(inactive), L=Low(active), D=Don't care.

# IC108/109 8bit CMOS Pseudo Static RAM

IC LH5P832N-10

IC TC51832FL-10

IC TC51832AFL-10

## Top View & Pin Layout

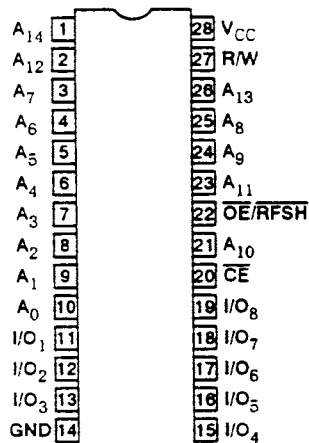

## Pin Configuration and Pin Description

Symbol	Pin Name
A <sub>c</sub> -A <sub>14</sub>	Address Input
R/W	Read / Write Input
OE / RFSH	Output Enable / Refresh
CE	Chip Enable
I/O <sub>i</sub> -I/O <sub>t</sub>	Data Input / Output

# IC110 PCM Sound Source

IC RF5C164A

Parts No. : 315-5476A

## Top View & Pin Layout

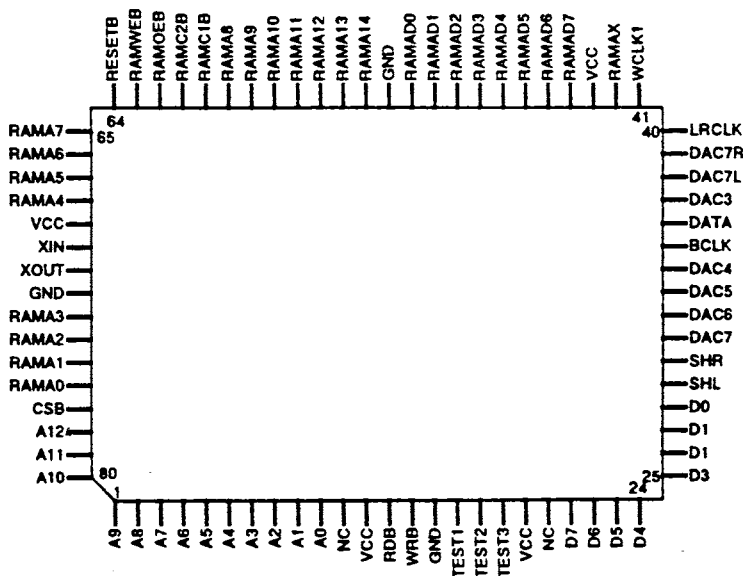

■ Description (IC110)

Pin No.	Name	I/O	Function
78	A12	I	Address signals from $\mu$ P.
79	A11		
80	A10		
1	A9		
2	A8		
3	A7		
4	A6		
5	A5		
6	A4		
7	A3		
8	A2		
9	A1		
10	A0	I/O	Data bus signals with $\mu$ P.
21	D7		
22	D6		
23	D5		
24	D4		
25	D3		
26	D2		
27	D1		
28	D0		
77	CSB	I	Chip select signal from $\mu$ P.
13	RDB	I	Read signal from $\mu$ P.
14	WRB	I	Write signal from $\mu$ P.
44	RAMAD7	I/O	When connected to a pseudo SRAM, these pins provide multiplex signals of the low order address/data to the SRAM, and when connected to an MROM, these pins provide data input signal from the MROM. When connected to an SRAM, these pins also provide data bus signals to the SRAM.
45	RAMAD6		
46	RAMAD5		
47	RAMAD4		
48	RAMAD3		
49	RAMAD2		
50	RAMAD1		
51	RAMAD0	O	High order address signals of the SRAM & MROM.
53	RAMA14		
54	RAMA13		
55	RAMA12		
56	RAMA11		
57	RAMA10		
58	RAMA9		
59	RAMA8	O	Low address signals of the SRAM & MROM.
65	RAMA7		
66	RAMA6		
67	RAMA5		
68	RAMA4		
73	RAMA3		
74	RAMA2		

Pin No.	Name	I/O	Function
75	RAMA1	O	Low address signals of the SRAM & MROM.
76	RAMA0		
42	RAMAX	O	LSB address signal of the MROM.
61	RAMC2B	O	High order 32k byte SRAM & MROM select signal.
6060	Note: The inter-	O	Low order 32k byte SRAM & MROM select signal.
63	RAMWEB	O	Signal to write data to the pseudo SRAM or SRAM.
62	RAMOEB	O	Signal to read data from the pseudo SRAM, SRAM or MROM.
31	DAC7	O	Multiplex signals of "R" and "L" data output to the parallel DAC.
32	DAC6		
33	DAC5		
34	DAC4		
37	DAC3		
29	SHL	O	DAC7-3 "L" data sample/hold signal.
30	SHR	O	DAC7-3 "R" data sample/hold signal.
39	DAC7R	O	Signal obtained by sampling and holding the DAC7 output at SHR.
38	DAC7L	O	Signal obtained by sampling and holding the DAC7 output at SHL.
41	WCLK1	O	Word clock signal output to the serial DAC.
40	LRCLK	O	LR clock signal output to the serial DAC.
36	DATA	O	Digital audio data signal output to the serial DAC.
35	BCLK	O	Bit clock signal output to the serial DAC.
64	RESETB	I	Reset signal.
70	XIN	I	An external crystal oscillator is connected. A clock signal is input to XIN directly.
71	XOUT	O	
16	TEST1	I	Test signal inputs. Normally, fixed at "L". However, TEST2 is fixed at "H" when an MROM or SRAM is used.
17	TEST2		
18	TEST3		
12	VCC	-	Power supply pins.
19			
43			
69			
15	GND	-	Ground pins.
52			
72			

Note: The interface with the serial DAC is formed in the MSB initial mode.

## ■ Block Diagram (IC110)

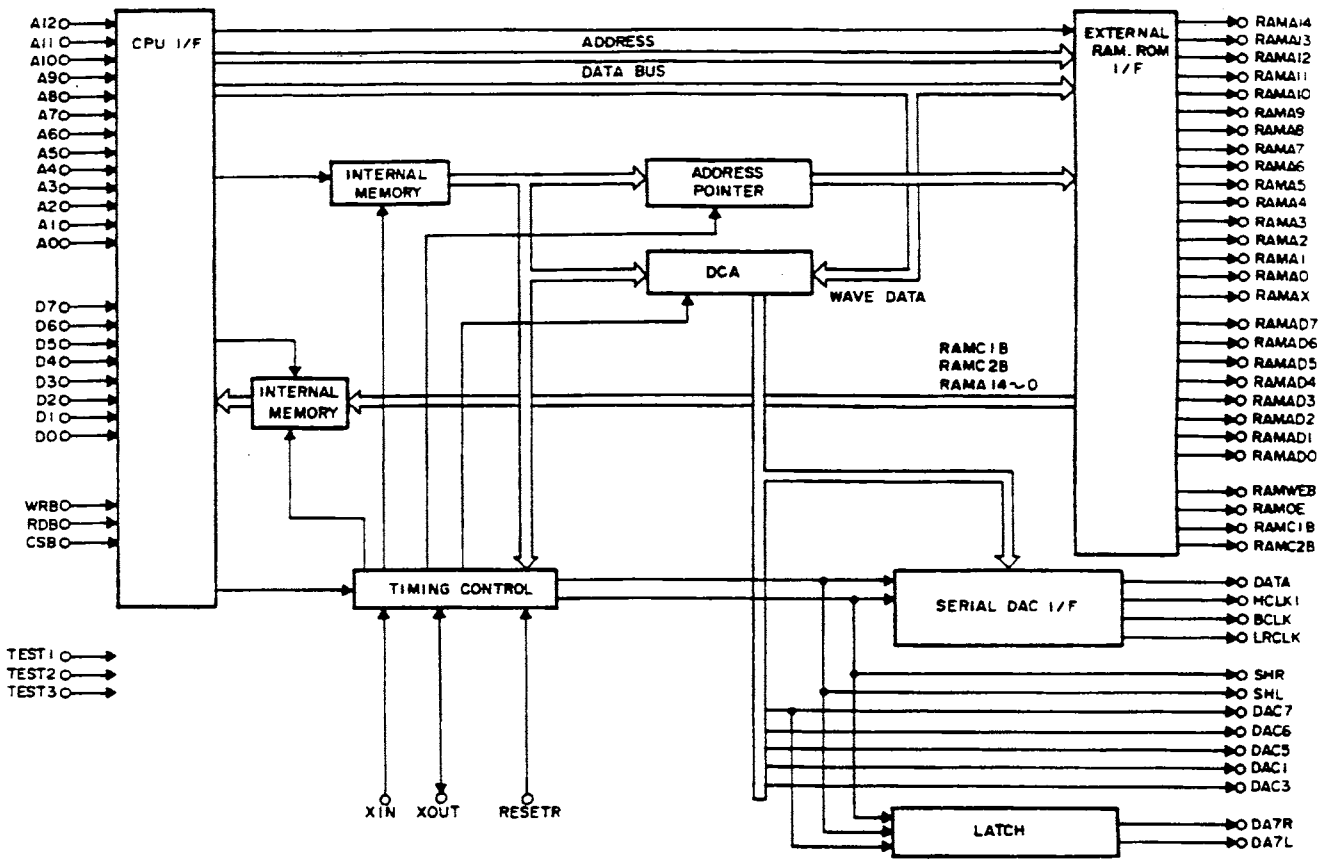

## IC111 1Mbit CMOS Masked Programmable ROM

IC SEGA-CD2 BOOT ROM EP  
IC MEGA-CD2 (PAL) BOOT ROM

IC SEGA-CD2 USA BOOT ROM

IC MEGA-CD2 BOOT EP MULTI

## ■ Top View & Pin Layout

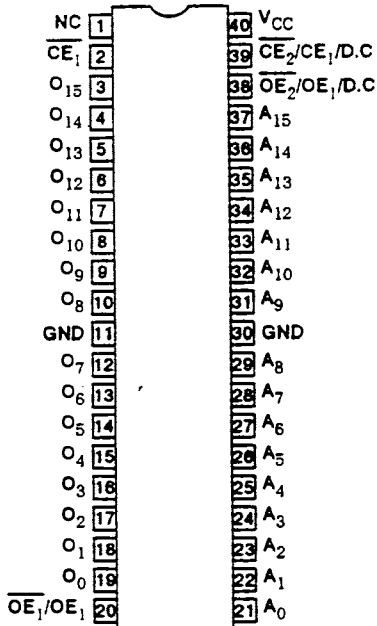

## ■ Block Diagram

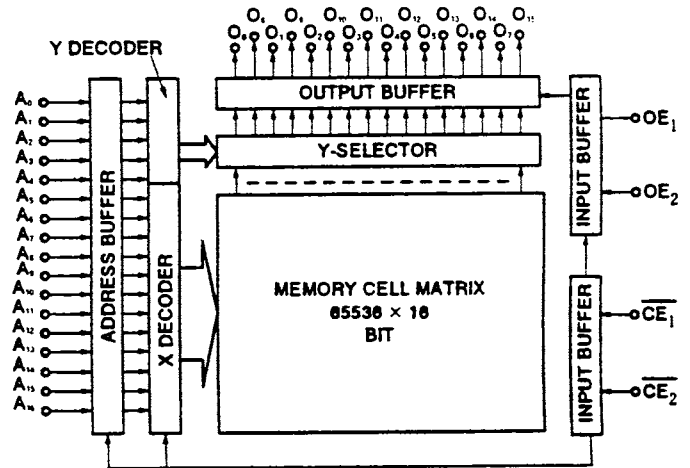

## ■ Operation Mode

$\overline{CE}_1$	$CE_2$	$OE_1$	$OE_2$	Mode	Output
I	X	X	X	Non-selective	High Impedance
X	I	X	X		
A	A	I	X	Selective	Data
A	A	X	I		
A	A	A	A		

# IC112 64k(8k × 8)bit Static RAM

IC MB8464A-10LL

## Top View & Pin Layout

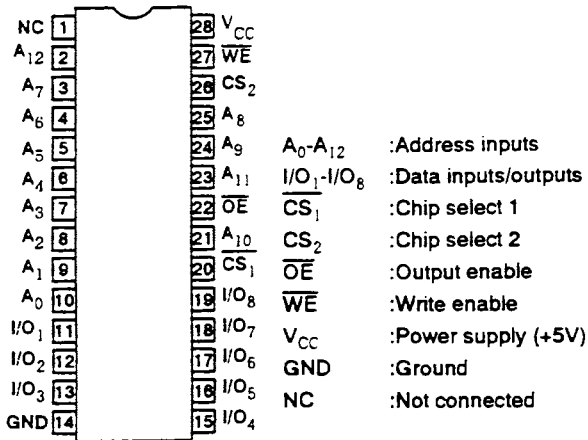

## Block Diagram

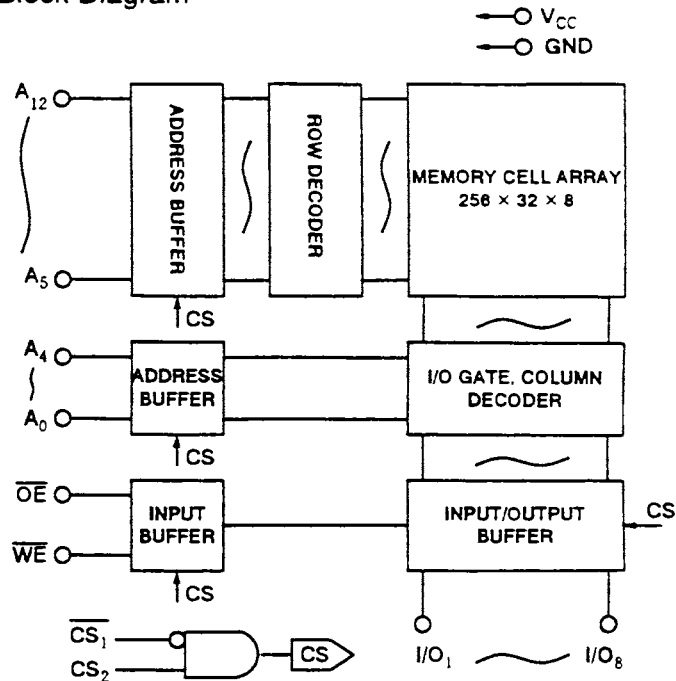

# IC113 16/32-Bit Microprocessor

IC MC68HC000FN12

IC HD68HC000CP-12

## Top View & Pin Layout

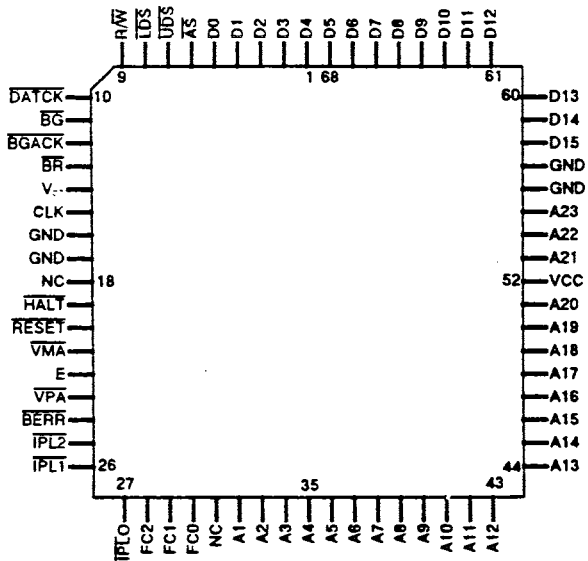

IC TMP68HC000T-12

## Signal Description

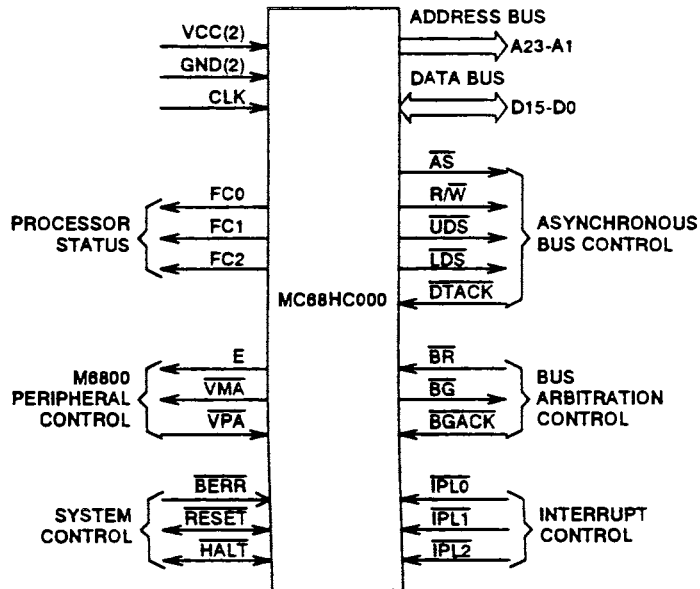

■ Description

No.	Pin Name	I/O	Function
1	D <sub>4</sub>	I/O	Data Bus
2	D <sub>3</sub>		
3	D <sub>2</sub>		
4	D <sub>1</sub>		
5	D <sub>0</sub>		
6	$\overline{AS}$	O	Address Strobe
7	$\overline{UDS}$	O	Upper Data Strobe
8	$\overline{LDS}$	O	Lower Data Strobe
9	R/W	O	Read/Write
10	$\overline{DTACK}$	I	Data Transfer Acknowledge
11	$\overline{EG}$	O	Bus Grant
12	$\overline{BGACK}$	I	Bus Grant Acknowledge
13	$\overline{BR}$	I	Bus Request
14	V <sub>CC</sub>	-	Power Supply
15	CLK	I	Clock
16	V <sub>SS</sub>	-	GND
17	V <sub>SS</sub>	-	GND
18	NC	-	Not Connected
19	$\overline{HALT}$	I/O	Halt
20	$\overline{RES}$	I/O	Reset
21	VMA	O	Valid Memory Address
22	E	O	Enable

No.	Pin Name	I/O	Function
23	$\overline{VPA}$	I	Valid Peripheral Address
24	$\overline{BERR}$	I	Bus Error
25	$\overline{IPL}_2$	I	Interrupt Control
26	$\overline{IPL}_1$		
27	$\overline{IPL}_0$		
28	FC <sub>2</sub>		
29	FC <sub>1</sub>	O	Processor Status
30	FC <sub>0</sub>		
31	N.C	-	
32	A <sub>1</sub>	O	Address Bus
33	A <sub>2</sub>		
34	A <sub>3</sub>		
35	A <sub>4</sub>		
36	A <sub>5</sub>		
37	A <sub>6</sub>		
38	A <sub>7</sub>		
39	A <sub>8</sub>		
40	A <sub>9</sub>		
41	A <sub>10</sub>		
42	A <sub>11</sub>		
43	A <sub>12</sub>		
44	A <sub>13</sub>		
45	A <sub>14</sub>		

No.	Pin Name	I/O	Function		
46	A <sub>15</sub>	O	Address Bus		
47	A <sub>16</sub>				
48	A <sub>17</sub>				
49	A <sub>18</sub>				
50	A <sub>19</sub>				
51	A <sub>20</sub>	-	Power Supply		
52	V <sub>CC</sub>				
53	A <sub>21</sub>	O	Address Bus		
54	A <sub>22</sub>				
55	A <sub>23</sub>	I/O	Data Bus		
56	V <sub>SS</sub>			-	GND
57	V <sub>SS</sub>			-	GND
58	D <sub>15</sub>				
59	D <sub>14</sub>				
60	D <sub>13</sub>				
61	D <sub>12</sub>				
62	D <sub>11</sub>				
63	D <sub>10</sub>				
64	D <sub>9</sub>				
65	D <sub>8</sub>				
66	D <sub>7</sub>				
67	D <sub>6</sub>				
68	D <sub>5</sub>				

IC114 Battery Back-up

IC MB3790

■ Top View & Pin Layout

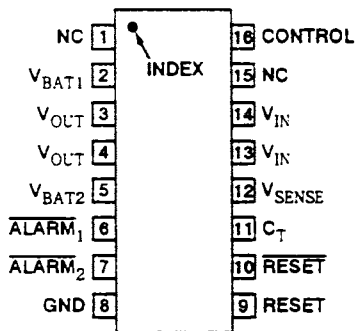

■ Block Diagram

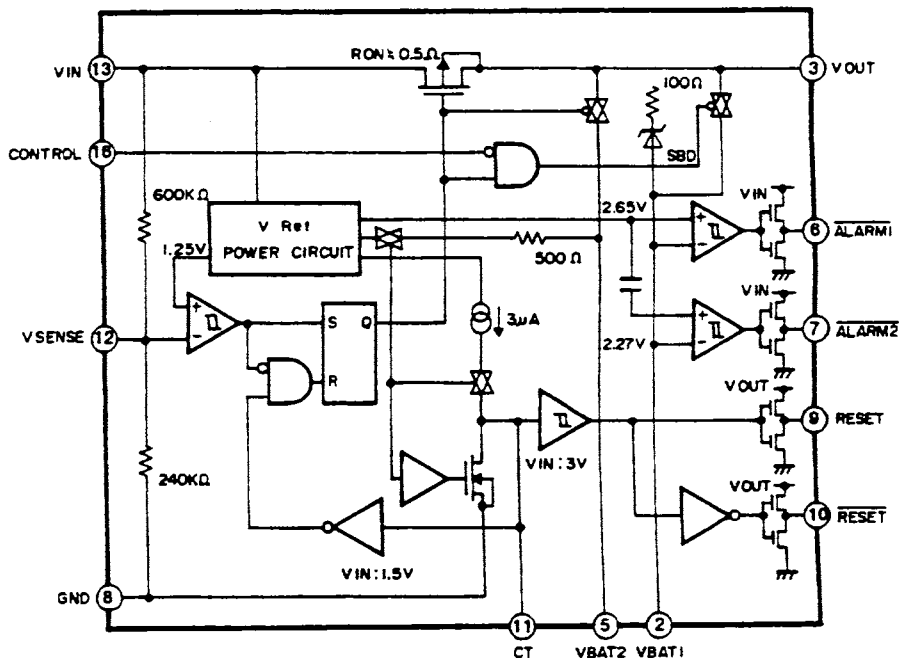

# IC116 CMOS Quad Exclusive OR Gate

IC TC74HC86

## Top View & Pin Layout

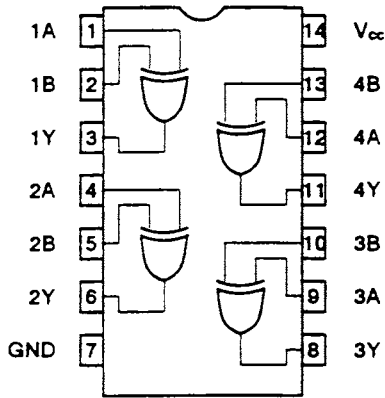

## Truth Table

A	B	Y
H	H	L
L	H	H
H	L	H
L	L	L

# IC201 18Bit Digital Filter & 16Bit D/A Converter

IC LC7883KM

## Top View



## Description

Pin	Name	I/O	Function
1	CH1OUT	O	DAC CH-1 output.
2	VrefH	-	Reference voltage "H" input.
3	AVDD	-	Power supply of analog circuits.
4	DVDD	-	Power supply of digital circuits.
5	BLCK	I	Bit clock.
6	DATA	I	Digital audio data input. Input from the MSB in the bit serial state.
7	LRCK	I	L/R clock input. LRCK= "H" CH1 LRCK= "L" CH2
8	TEST	I	Test pin. (normally, set to "L")
9	ATT	I	Attenuator data input. Input from the LSB in the bit serial state.
10	SHIFT	I	Attenuator data transfer clock input.
11	LATCH	I	Attenuator data latch clock input.
12	INITB	I	Initializing signal input. (normally, set to "H")
13	TEST	I	Test pin. (normally, set to "L")

Pin	Name	I/O	Function
14	EMPH2	I	De-emphasis setting pins.
15	EMPH1		
16	D/N	I	Double/Normal speed switching pin.
17	SOC2	I	Input source select inputs. (PULL-DOWN)
18	SOC1		
19	MODE	I	Operation mode setting pin. (PULL-DOWN)
20	TEST	I	Test pins. (normally, set to "L") (PULL-DOWN)
21			
22	DGND	-	Ground of digital circuits.
23	CLKOUT	O	Clock output. 392Fs: 1/2 XOUT 384Fs, 448Fs, 512Fs : XOUT
24	XIN	I	Crystal oscillator input.
25	XOUT	O	Crystal oscillator output.
26	AGND	-	Ground of analog circuits.
27	VrefL	-	Reference voltage "L" input.
28	CH2OUT	O	DAC CH-2 output.

# IC202 16Bit D/A Converter

IC LC78815M

## Top View

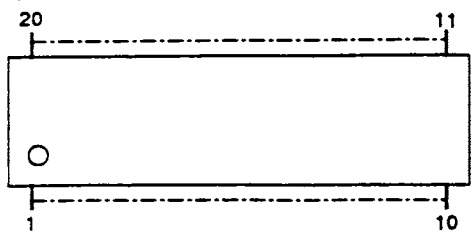

## Description

Pin No.	Name	I/O	Function	Pin No.	Name	I/O	Function
1	CH1OUT	O	CH-1 output. (L-ch)	12	FSEL	-	"L" : Digital audio data is input from the DATAL and DATAR pins simultaneously. "H" : Digital audio data is input from the DATAL pin by time-sharing.
2	REFH	-	Reference voltage "H".	13	MODE1	-	Interface switching.
3	VrefH	-	Reference voltage "H" input.	14	MOCE2	-	
4	AVDD	-	Supply voltage of analog circuits.	15	DGND	-	Ground of digital circuits.
5	LRCK/WCLK	I	LR clock/word clock input .	16	REFL	-	Reference voltage "L".
6	DATAL	I	Digital audio data input.	17	AGND	-	Ground of analog circuits.
7	DATAR	I	Digital audio data input.	18	VrefL	-	Reference voltage "L" input.
8	BCLK	I	Bit clock input.	19	NC	-	Not connected.
9	SYSCLK	I	System clock input.	20	CH2OUT	O	CH-2 output. (R-ch)
10	DVDD	-	Supply voltage of digital circuits.				
11	TSTOUT	O	Test output.				

# IC203/204 Quad Operational Amplifier

IC NJM3403AM

## Top View

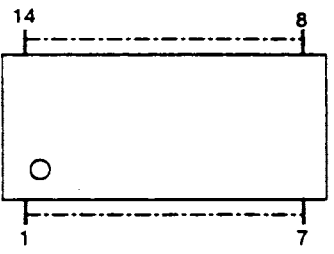

## Pin Layout

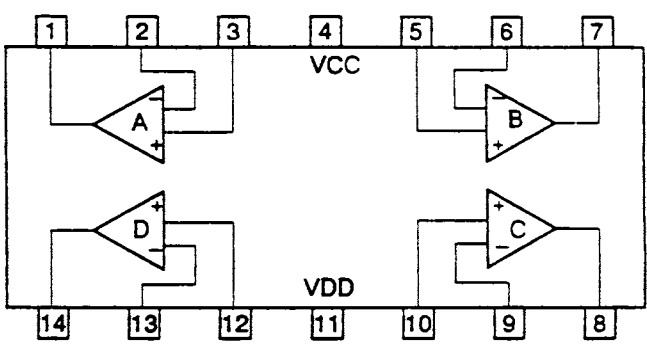

# IC205 Dual Operational Amplifier

IC NJM3404AM

## Top View

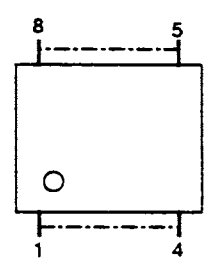

## Pin Layout

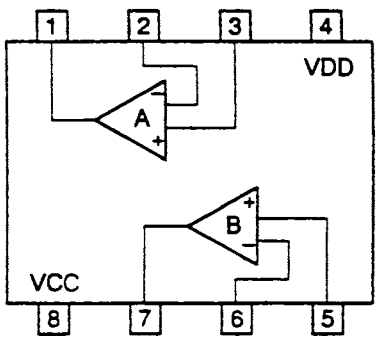

# IC301 3-Terminal Voltage Regulator

IC UPC2405HF

## ■ Front View

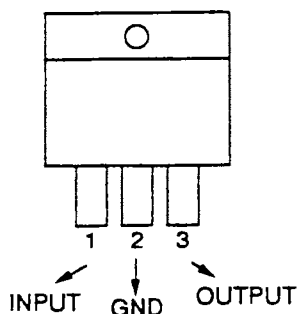

# IC401 Digital Processor for CD

IC CXD1167Q

## ■ Top View

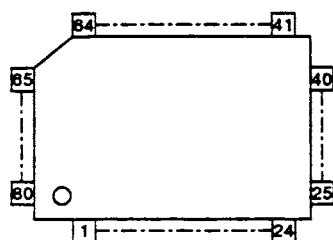

## ■ Description

Pin No.	Name	I/O	Function
1	FSW	O	Output to switch the time constant of the spindle motor's output filter.
2	MON	O	Spindle motor on/off control output.
3	MDP	O	Spindle motor drive output. Coarse control in the CLV-S mode and phase control in the CLV-P mode.
4	MDS	O	Spindle motor drive output. Speed control in the CLV-P mode.
5	EFM	I	EFM signal input from the RF amplifier.
6	ASY	O	Output to control the slice level of the EFM signal.
7	LOCK	O	When the GFS signal is sampled by WFCK/16 and the level is "H", this pin outputs "H" ; when the level is "L" for 8 times continuously, this pin outputs "L".
8	VCOO	O	VCO output. When locked to the EFM signal, the frequency is 8.6436MHz. (17.2872MHz in the double speed mode)
9	VCOI	I	VCO input.
10	TEST	I	(0V)
11	PDO	O	Output obtained by comparing the phases of the EFM signal and VCO/2.
12	V <sub>SS</sub>	-	GND (0V)
13	CLK	I	Serial data transfer clock input from CPU. Latches the data at the leading edge of the clock signal.
14	XLT	I	Latch input from CPU. Latches the data in the 8-bit shift register, (serial data from CPU) in each register.
15	DATA	I	Serial data input from CPU.
16	XRST	I	System reset input. Reset when "L" is input.
17	CNIN	I	Tracking pulse input.
18	SENS	O	Outputs the internal state according to the address.
19	MUTG	I	Muting input. When ATTM of internal register A is "L", MUTG "L" causes the normal state and MUTG "H", causes muting.
20	CRCF	O	Outputs the CRC check results of subcode Q.
21	EXCK	I	Clock input for serial output of subcodes.
22	SBSO	O	Serial output of subcodes.
23	SUBQ	O	Subcode Q output.



Pin No.	Name	I/O	Function
24	SCOR	O	Subcode sync S0 + S1 output.
25	SQCK	I/O	Subcode Q reading clock.
26	SQEX	I	SQCK select input. (see CPU interface)
27	DOTX	O	Digital output. (WFCK is output when DO is off)
28	GFS	O	Output to display the frame sync locked state.
29			
30	TEST	I	Fixed at "H" or "L", do not set to open.
31			
32			
33			
33	V <sub>DD</sub>	-	Power supply. (+5V)
34			
35			
36			
37			
38			
39			
40			
41	TEST	I	Fixed at "H" or "L", do not set to open.
42			
43			
44			
45			
46			
47			
48			
49			
50			
51	C4M	O	Crystal oscillator's frequency divided output. $f = 4.2336\text{MHz}$ . (8.4672MHz during double-speed play)
52	V <sub>SS</sub>	-	GND (0V)
53	XTAI	I	Crystal oscillator input. The frequency is determined as 8.4672MHz or 16.9344MHz (during double-speed play) by the mode select inputs.
54	XTAO	O	Crystal oscillator output. The frequency is determined as 8.4672MHz or 16.9344MHz (during double-speed play) by the mode select inputs.
55	MD1	I	Mode select input 1.
56	MD2	I	Mode select input 2.
57	MD3	I	Mode select input 3.
58	SLOB	I	Input to switch the audio data output code. "L": complementary output, "H": offset binary output.
59	PSSL	I	Input to switch the audio data output mode. "L": serial output, "H": parallel output.
60	APTR	O	Aperture correction control output. "H": R-ch.
61	APTL	O	Aperture correction control output. "H": L-ch.
62	DA01	O	DA01 (LSB of parallel audio data) output when PSSL is "H". C1F1 output when PSSL is "L".
63	DA02	O	DA02 output when PSSL is "H". C1F2 output when PSSL is "L".
64	DA03	O	DA03 output when PSSL is "H". C2F1 output when PSSL is "L".
65	DA04	O	DA04 output when PSSL is "H". C2F2 output when PSSL is "L".
66	DA05	O	DA05 output when PSSL is "H". C2FL output when PSSL is "L".
67	DA06	O	DA06 output when PSSL is "H". C2PO output when PSSL is "L".
68	DA07	O	DA07 output when PSSL is "H". RFCK output when PSSL is "L".
69	DA08	O	DA08 output when PSSL is "H". WFCK output when PSSL is "L".
70	DA09	O	DA09 output when PSSL is "H". $\overline{\text{PLCK}}$ output when PSSL is "L".
71	DA10	O	DA10 output when PSSL is "H". UGFS output when PSSL is "L".
72	DA11	O	DA11 output when PSSL is "H". GTOP output when PSSL is "L".
73	V <sub>DD</sub>	-	Power supply. (+5V)
74	DA12	O	DA12 output when PSSL is "H". RA0V output when PSSL is "L".
75	DA13	O	DA13 output when PSSL is "H". C4LR output when PSSL is "L".
76	DA14	O	DA14 output when PSSL is "H". BCLK output when PSSL is "L".
77	DA15	O	DA15 output when PSSL is "H". $\overline{\text{BCLK}}$ output when PSSL is "L".
78	DA16	O	DA16 (MSB of parallel audio data) output when PSSL is "H". DATA output when PSSL is "L".
79	WDCK	O	Strobe signal output. 176.4kHz (352.8kHz in double-speed play) when DF is on, and 88.2kHz (176.4kHz in double-speed play) when DF is off.
80	LRCK	O	Strobe signal output. 88.2kHz (176.4kHz in double-speed play) when DF is on, and 44.1kHz (88.2kHz in double-speed play) when DF is off.

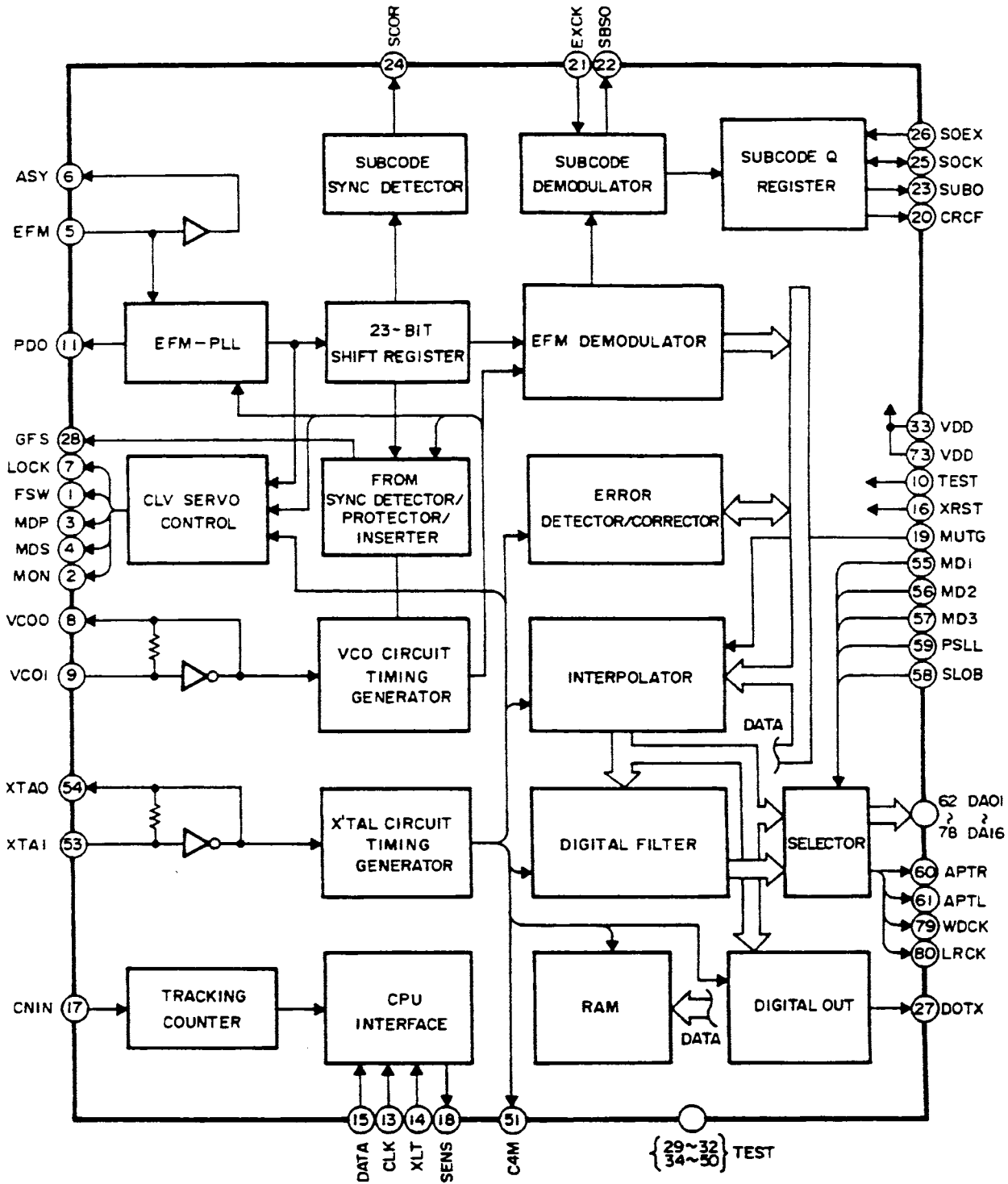

# IC402 RF Amplifier for CD

IC CXA1081M

## Top View

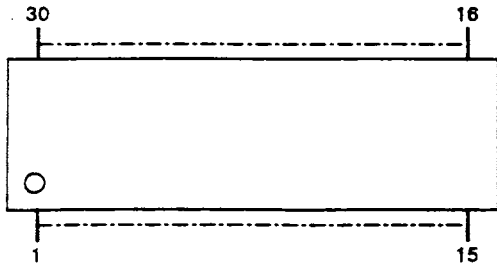

## Block Diagram

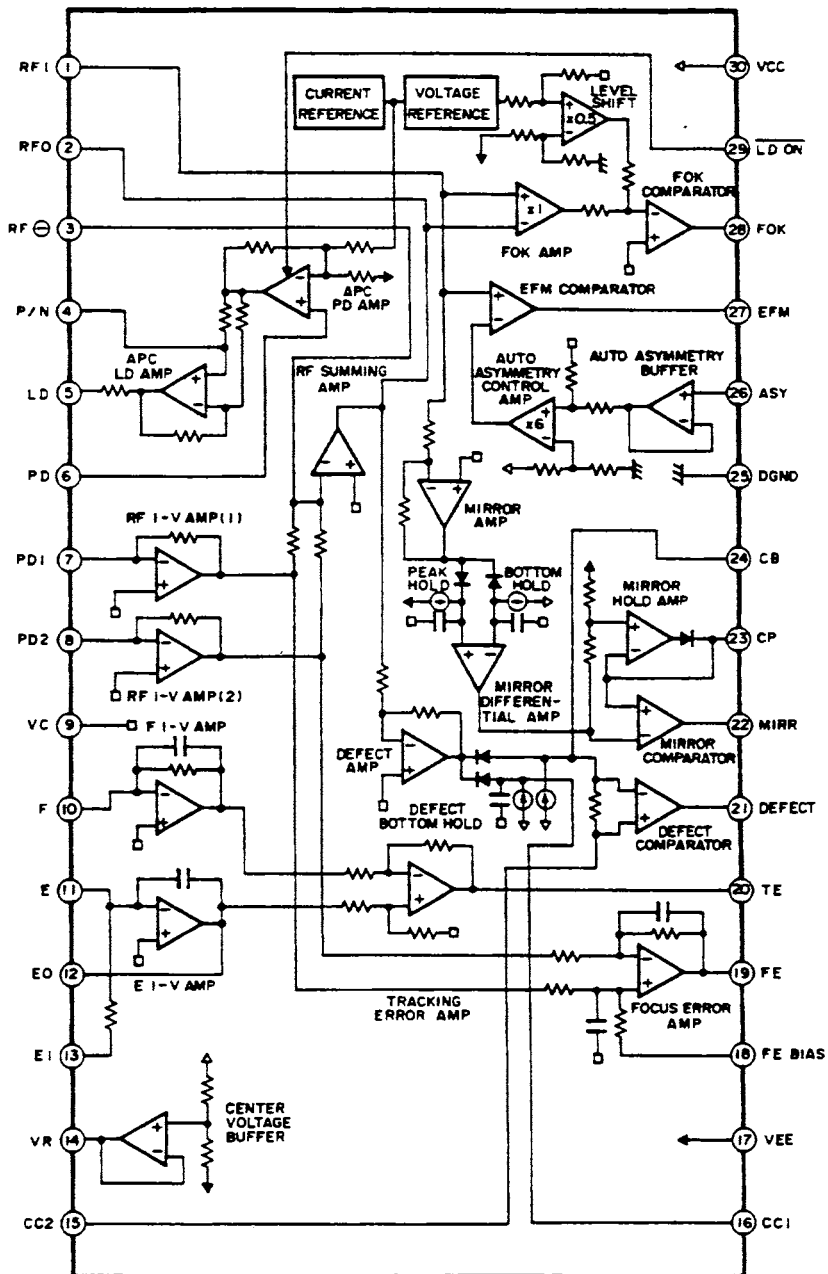

Pin No.	Name	I/O	Function
1	RFI	I	The RF summing amp outputs are capacity-coupled before input.
2	RFO	O	RF summing amp output. Eye pattern check point
3	RF $\ominus$	I	RF summing amp feedback input.
4	P/N	I	Laser diode (LD) P-sub/N-sub switching. (DC voltage: when switched to N-sub)
5	LD	O	Automatic power control (APC) LD amp output. (DC voltage, when switched to N-sub, PD open)
6	PD	I	Automatic power control(APC) PD amp input. (DC voltage: open)
7	PD1	I	RF I-V amp (1) inverting input. Connected to the A + C terminal of the photodiode and the current is input.
8	PD2	I	RF I-V amp (2) inverting input. Connected to the B + D terminal of the photodiode and the current is input.
9	VC	-	With positive/negative power supplies: GND. With single power supply: VR. (connected to pin 14)
10	F	I	F I-V amp inverting input. Connected to the F terminal of the photodiode and the current is input.
11	E	I	E I-V amp inverting input. Connected to the E terminal of the photodiode and the current is input.
12	EO	O	E I-V amp output.
13	EI	I	E I-V amp feedback input. Used to adjust the gain of the E I-V amp.
14	VR	O	$(V_{CC} + V_{EE}) / 2$ V DC output.
15	CC2	I	The DEFECT bottom hold outputs are capacity-coupled and input.
16	CC1	O	DEFECT bottom hold output.
17	V <sub>EE</sub>	-	With positive/negative power supplies: Negative power supply pin. With single power supply: GND.
18	FE BIAS	I	Bias pin for the non-inverting input of focus error amp. Used for CMR adjustment of the focus error amp.
19	FE	O	Focus error amp output.
20	TE	O	Tracking error amp output.
21	DEFECT	O	DEFECT comparator output. (DC voltage: with 10k $\Omega$ resistor connected)
22	MIRR	O	MIRR comparator output. (DC voltage: with 10k $\Omega$ resistor connected)
23	CP	I	A MIRR hold capacitor is connected. Non-inverting input of the MIRR comparator.
24	CB	I	A DEFECT bottom hold capacitor is connected.
25	D <sub>GND</sub>	-	With positive/negative power supplies: GND. With single power supply: GND. (VEE)
26	ASY	I	Auto asymmetry control input.
27	EFM	O	EFM comparator output. (DC voltage: with 10k $\Omega$ load resistor connected)
28	FOK	O	Focus OK comparator output. (DC voltage: with 10k $\Omega$ load resistor connected)
29	$\overline{\text{LD ON}}$	I	Laser diode (LD) on/off switching. (DC voltage: when LD is turned on)
30	V <sub>CC</sub>	-	Positive power supply.

Note: Values in brackets ( ) are for CXA1081Q. ( $V_{CC}=2.5V$ ,  $V_{EE} = D_{GND} = -2.5V$ ,  $VC=GND$ )

# IC403 Servo Signal Processor for CD

IC CXA1082Q

## Top View

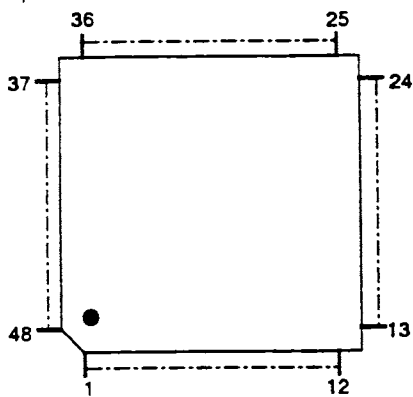

## Block Diagram

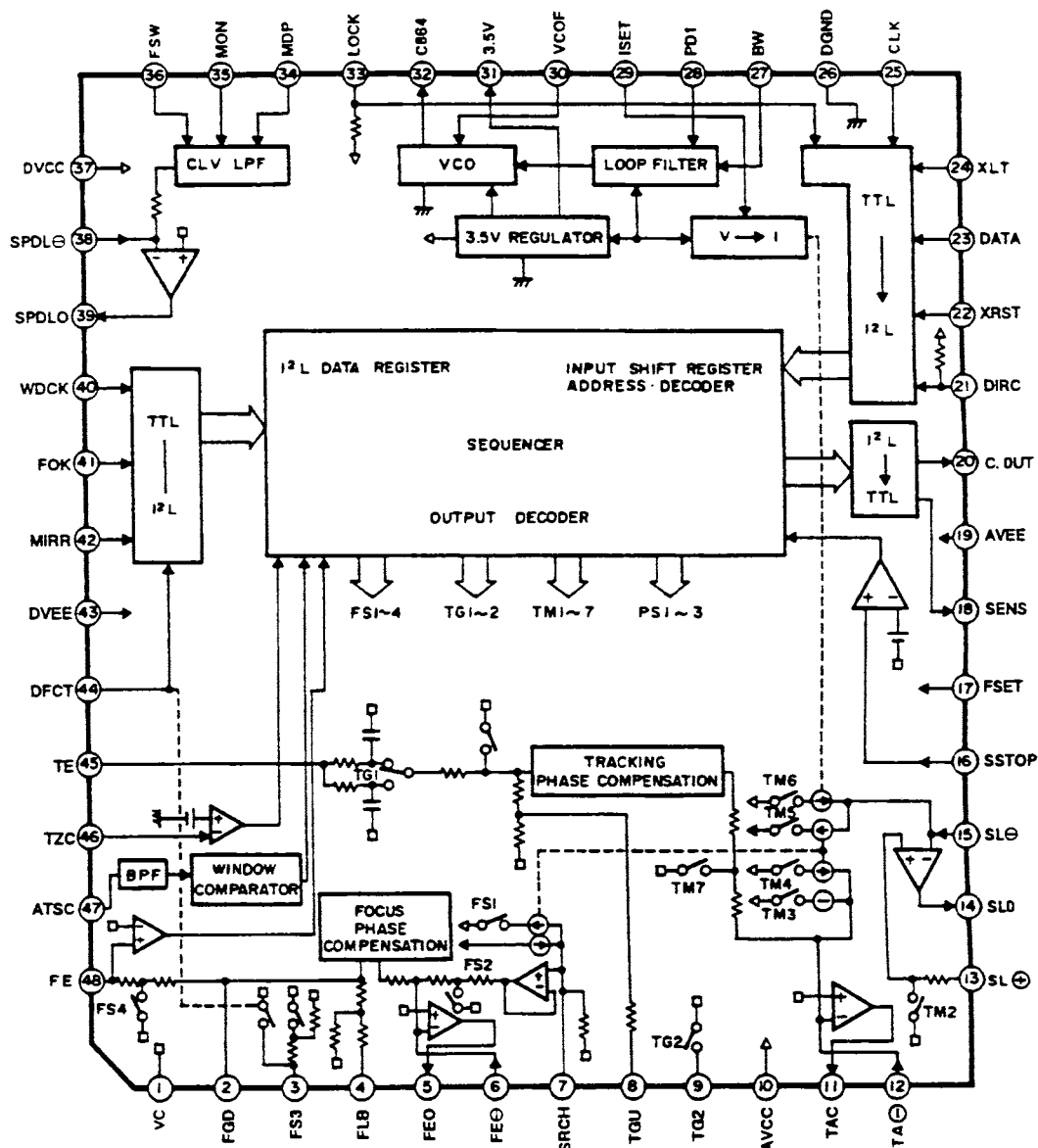

■ Description

Pin No.	Name	I/O	Function
2	FGD	—	A capacitor is inserted between this pin and pin ③ to decrease the focus servo high-frequency gain.
3	FS3	—	FS3 is turned on or off to switch the focus servo high-frequency gain.
4	FLB	—	Time constant components are connected externally to boost the focus servo low frequencies.
5	FEO	O	Focus drive output.
6	FE $\ominus$	I	Focus amp inverting input.
7	SRCH	—	Time constant components are connected externally to form the focus search waveform.
8	TGU	—	Time constant components are connected externally to switch the tracking high-frequency gain.
9	TG2	—	Time constant components are connected externally to switch the tracking high-frequency gain.
11	TAO	O	Tracking drive output.
12	TA $\ominus$	I	Tracking amp inverting input.
13	SL $\oplus$	I	Sled amp non-inverting input.
14	SLO	O	Sled drive output.
15	SL $\ominus$	I	Sled amp inverting input.
16	SSTOP	—	Signal to detect whether the limit switch that detects the disc innermost edge is turned on or off.
17	FSET	—	Determines the peak of the focus/tracking phase compensation and the frequency (fo) of CLV LPF.
18	SENS	O	Outputs FZC, AS, TZC, SSTOP and $\overline{\text{BUSY}}$ , instructed by commands from the CPU.
20	C.OUT	O	Outputs a signal to count the number of tracks.
21	DIRC	—	Used to jump one track. A 47k $\Omega$ pull-up resistor is incorporated.
22	XRST	—	Reset when "L" is input to the reset input.
23	DATA	I	Serial data input from the CPU.
24	XLT	I	Latch input from the CPU.
25	CLK	I	Serial data transfer clock input from the CPU.
27	BW	—	Time constant components of the loop filter is connected externally.
28	PDI	I	The CX23035/CXD1135 phase comparator output PDO is input.
29	ISET	—	Supplies the current that determines the levels of the focus search, track jump and sled kick.
30	VCOF	—	The VCO free-running frequency is proportional to the resistance between this pin and pin ③.
32	C864	O	8.64MHz VCO output.
33	LOCK	—	"L" activates the sled run-out prevention circuit. A 47k $\Omega$ pull-up resistor is incorporated.
34	MDP	—	The MDP pin of the CX23035/CXD1135 is connected.
35	MON	—	The MON pin of the CX23035/CXD1135 is connected.
36	FSW	—	Time constant components of the LPF for the CLV servo error signal are connected externally.
38	SPDL $\ominus$	I	Spindle drive amp inverting input.
39	SPDLO	O	Spindle drive output.
40	WDCK	I	Clock input for auto sequence. Normally, 88.2kHz is input.
41	FOK	I	FOK signal input.
42	MIRR	I	Mirror signal input.
44	DFCT	I	DEFECT signal input. "H" activates the defect troubleshooting circuit.
45	TE	I	Tracking error signal input.
46	TZC	I	Tracking zero-cross comparator input.
47	ATSC	I	ATSC detection window comparator input.
48	FE	I	Focus error signal input.

# IC404 4Bit Single Chip Microcomputer

IC UPD75P008GB IC UPD75006GB

## Top View

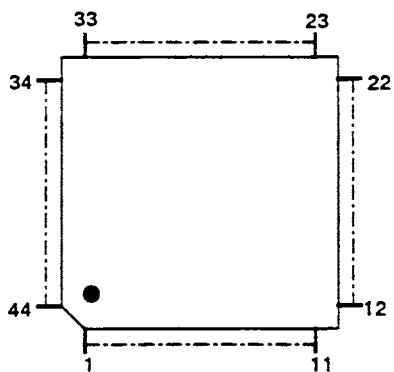

## Description

Pin No.	Port Name	Pin Name	I/O	Function
1	P72	—		Not used.
2	P71	MUTG	O	Digital muting control for CXD1167Q. "H": Muting.
3	P70	TIR Q	—	Not used.
4	P63	CLK	O	Serial data transfer to CXA1082BQ and CXD1167Q.
5	P62	XLT		
6	P61	DATA		
7	P60	GAIN	—	Disc servo gain switching.
8	P53	TDB3	—	Not used.
9	P52	TDB2	—	
10	P51	TDB1	—	
11	P50	TDB0	—	
13	P43	DB3	I/O	Data bus with the host CPU.
14	P42	DB2		
15	P41	DB1		
16	P40	DB0		
23	P33	—	—	Not used.
24	P32	L-MUTE	O	Muting output. "L": during music play, "H": in other modes.
25	P31	CDCK	O	CD mechanism control clock.
26	P30	IRQ	O	Interrupt request.
27	P81		I	Open/close switch.
28	P80	HOCK	I	Host CPU clock.
29	P03(SI)	SUB Q	I	Q-code serial data input.
30	P02(SO)	—	—	Not used.
31	P01(SCK)	SQCK	O	Serial clock to read Q codes.
32	P00(INT4)	—	—	Not used.
33	P13	—	—	Not used.
35	P12(INT2)	—	—	Not used.
36	P11(INT1)	SCOR	I	External interrupt request to read Q codes. Interrupt at the leading edge.
37	P10(INT0)	SENS1	I	CXA1082/CXD1167Q sensing input.
40	P23	THOCK	—	Not used.
41	P22	TEST1	I	Test input. "H": Normal, "L": Test.
42	P21	FOK	I	Focus OK signal input.
43	P20	SENS	I	CXA1082/CXD1167Q sensing input.
44	P73	LDON	O	Laser diode on/off switching. "H": LD ON.

## ■ Block Diagram

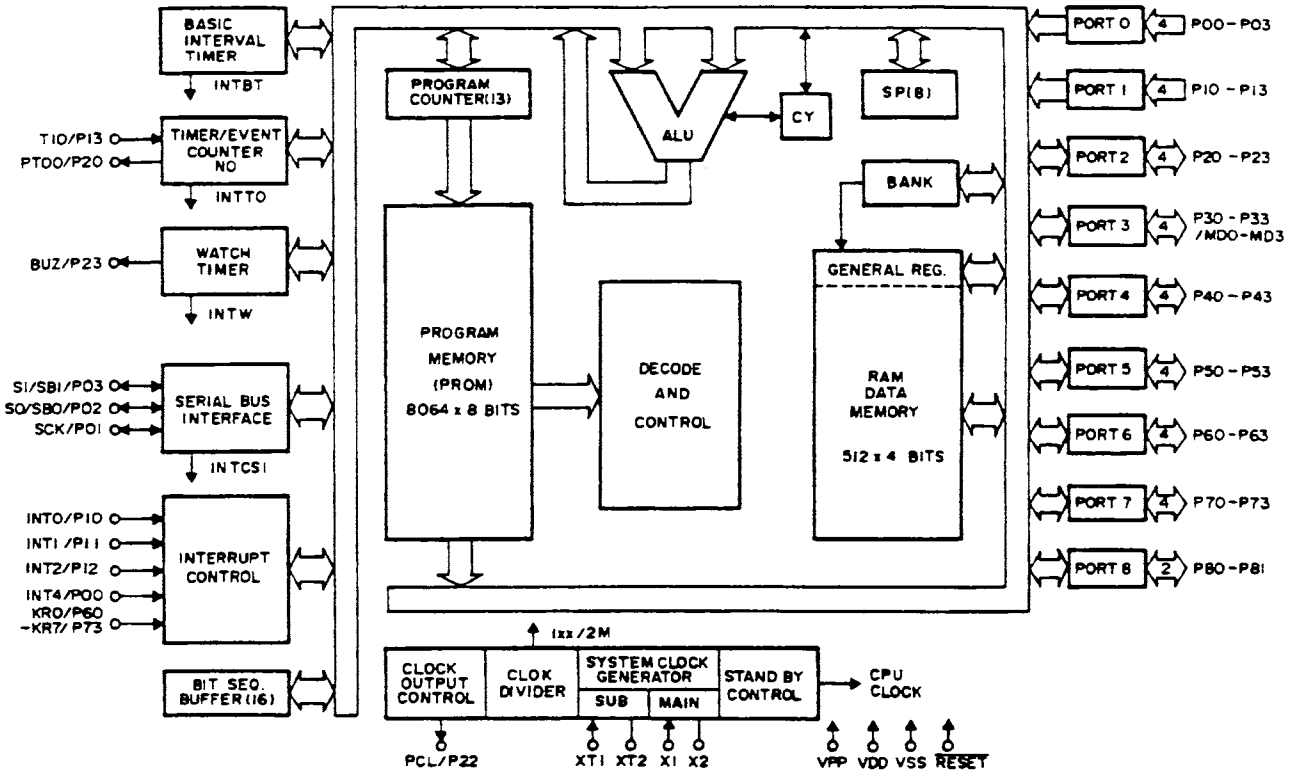

## IC407 CMOS Inverter

IC 74HCU04

Parts No. : 314-0571

### ■ Top View

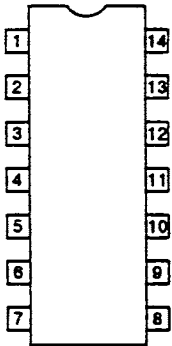

### ■ Pin Layout

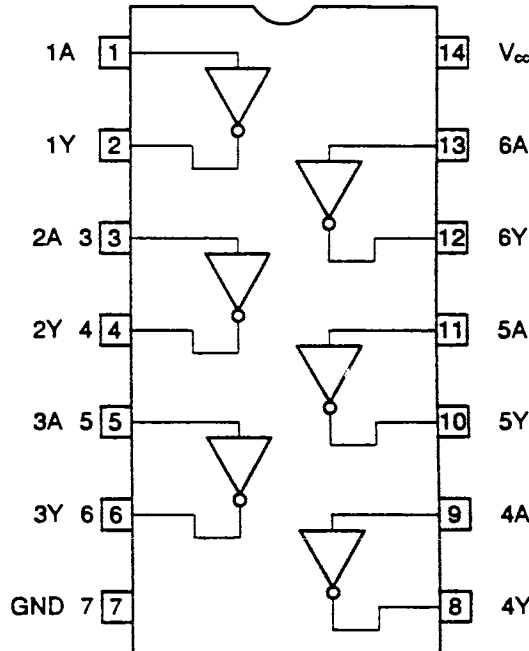

### ■ Truth Table

A	Y
L	H
H	L



## IC408 Bilateral Switch

IC TC4S66F-TE85R

### Top View

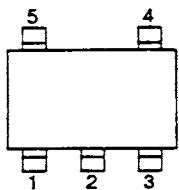

### Pin Layout

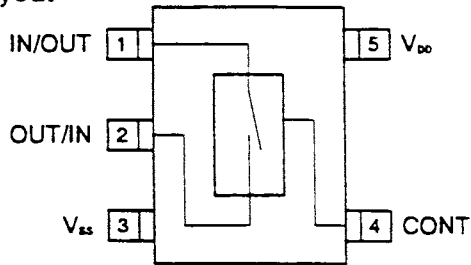

## IC409 4ch Linear Driver

IC AN8388SR

IC AN8388NSRBE1

### Top View

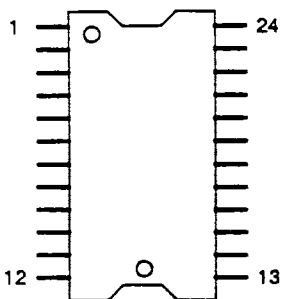

### Block Diagram

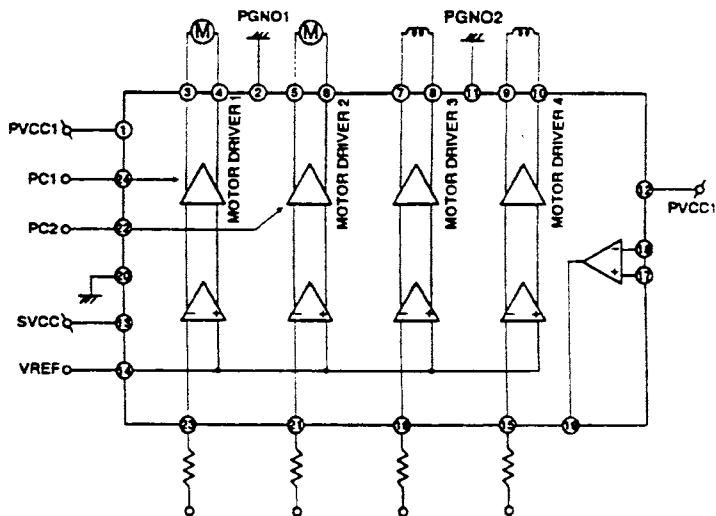

### Description

Pin No.	Function
1	Driver power supply pin 1
2	Driver ground pin 1
3	Motor driver 1 reverse run output
4	Motor driver 1 forward run output
5	Motor driver 2 reverse run output
6	Motor driver 2 forward run output
7	Motor driver 3 reverse run output
8	Motor driver 3 forward run output
9	Motor driver 4 reverse run output
10	Motor driver 4 forward run output
11	Driver ground pin 2
12	Driver power supply pin 2

Pin No.	Function
13	Power supply pin
14	VREF input pin
15	Motor driver 4 input
16	Motor driver 3 input
17	OP amp forward input pin
18	OP amp reverse input pin
19	OP amp output
20	Ground pin
21	Motor driver 2 input
22	PC2 (power cutoff) input
23	Motor driver 1 input
24	PC1 (power cutoff) input

## IC601 System Reset

IC PST529F MMP3P

### Top View

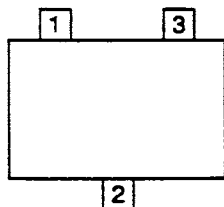

### Block Diagram

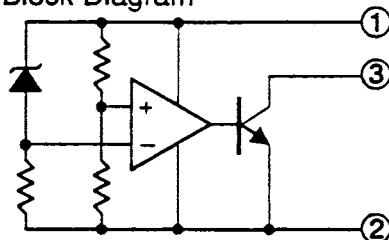

# 13. EXPLODED VIEW & PARTS LIST

## 13-1. Exploded View

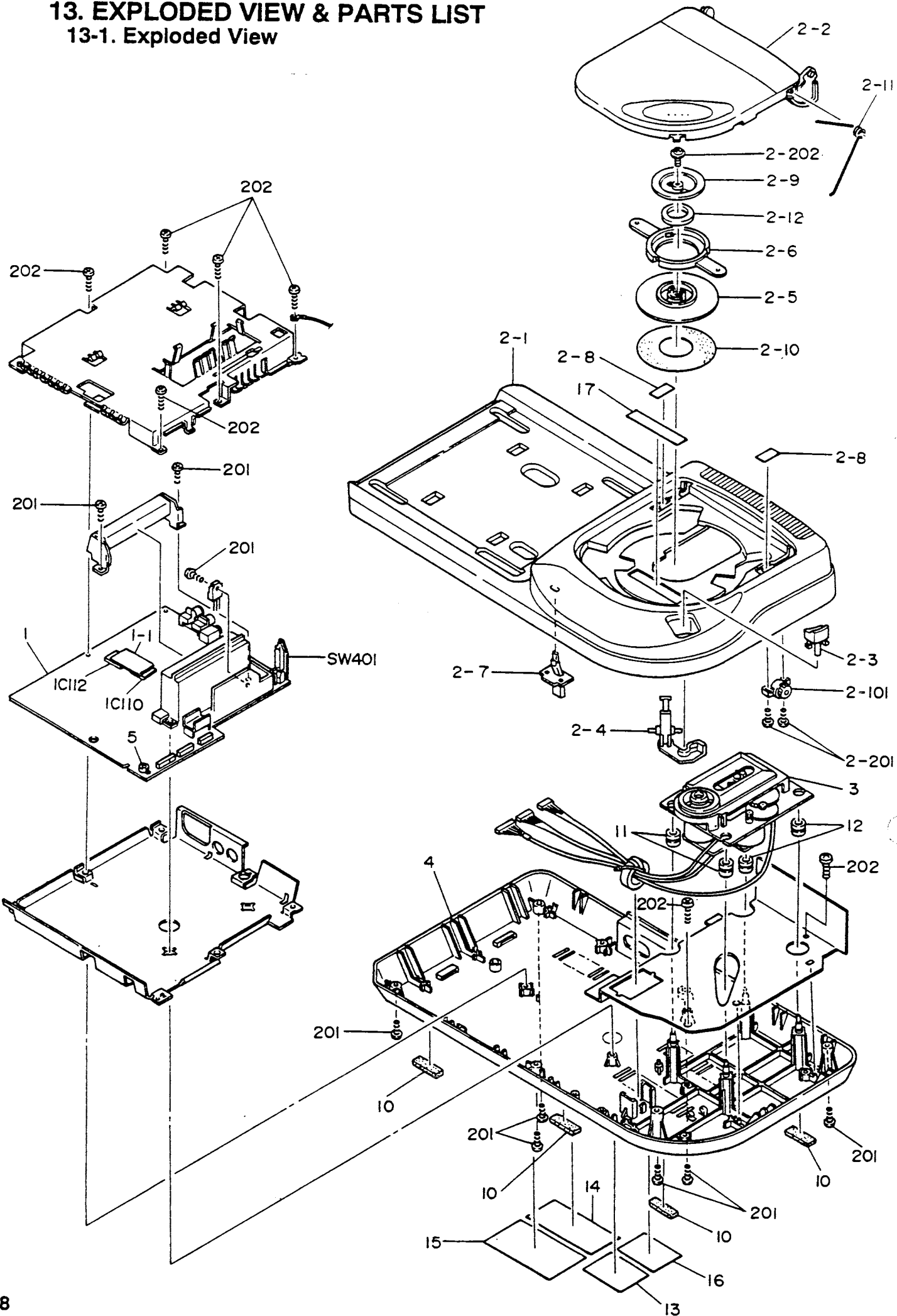

### 13-2. Mechanical Parts List

### 13-3. Electrical Parts List

Ref. No.	Parts No.	Description	Circuit No.	Parts No.	Description
1	837-9615	IC BD SEGA-CD2 MAIN BD USA (CBA) [S]	IC001	314-0367	IC 74HC04
1	837-9616	IC BD MEGA-CD2 MAIN BD MULTI (CBA) [M]	IC002	314-0407	IC 74HC74
1-1	837-9798	IC BD MEGA-CD2 PCM BD	IC101	315-5632	IC CUSTOM CHIP MCE3 FUJITSU
2-1	253-6661	TOP CASE MEGA-CD2 EXPORT	IC102	315-0745-80	IC TC511664BJ-80 SOJ TOSHIBA
2-2	253-6635	DOOR SEGA-CD2 USA [S]	IC102	315-0804-70	IC UPD421664LE-70 SOJ NEC
2-2	253-6636	DOOR MEGA-CD2 MULTI [M]	IC102	315-0804-80	IC UPD421664-80 SOJ NEC
2-3	253-6562-01	DOOR KNOB SEGA-CD2 USA [S]	IC102	315-0805-80	IC UPD421664-80L SOJ NEC
2-3	253-6562-02	DOOR KNOB MEGA-CD2 MULTI [M]	IC103	315-0745-80	IC TC511664BJ-80 SOJ TOSHIBA
2-4	253-6563	DOOR LEVER MEGA-CD2	IC103	315-0804-70	IC UPD421664LE-70 SOJ NEC
2-5	253-6564	CHUCK DISK MEGA-CD2	IC103	315-0804-80	IC UPD421664-80 SOJ NEC
2-6	253-6565	CHUCK HOLDER MEGA-CD2	IC103	315-0805-80	IC UPD421664-80L SOJ NEC
2-7	253-6566	LED LENS MEGA-CD2	IC104	315-0796-70	IC CXX5864BM-70 SOP SONY
2-8	253-6569	BLIND SHEET MEGA-CD2	IC105	315-0796-70	IC CXX5864BM-70 SOP SONY
2-9	250-5306	CONNECT PLATE MEGA-CD2	IC106	315-5181-01	IC LC89515 QFP SANYO
2-10	601-6983	CHUCK SHEET MEGA-CD2	IC107	315-0739-80	IC UPD424270LE-80 NEC
2-11	125-5101	DOOR SPRING MEGA-CD2	IC107	315-0777-80	IC HM514270AJ-8 SOJ HITACHI
2-12	113-0020	MAGNET MEGA-CD2	IC107	315-0818	IC M5M44270AJ-8 SOJ MITSUBISHI
2-101	601-7018	OIL DAMPER MEGA-CD2	IC107	315-0822-80	IC MN414270SJ-08 SOJ PANASONIC
2-201	012-P00210	TAP SCR PH M2x10	IC108	315-0760-10	IC LH5P832N-10 SOP SHARP
2-202	029-000016	CUP SCR M2.6x5	IC108	315-0677	IC TC51832FL-10 SOP TOSHIBA
3	610-5424	CD DRIVE UNIT MEGA-CD2	IC108	315-0759-10	IC TC51832AFL-10 SOP TOSHIBA
4	253-6651	BOTTOM CASE MEGA-CD2 EXPORT	IC109	315-0760-10	IC LH5P832N-10 SOP SHARP
5	253-6567	LED HOLDER MEGA-CD2	IC109	315-0677	IC TC51832FL-10 SOP TOSHIBA
10	601-6982	RUBBER FOOT MEGA-CD2	IC109	315-0759-10	IC TC51832AFL-10 SOP TOSHIBA
11	601-6984	RUBBER DAMPER A MEGA-CD2	IC110	315-5476A	IC CUSTOM CHIP RF5C164A RICOH
12	601-7002	RUBBER DAMPER B MEGA-CD2	IC111	EPR-15511	IC SEGA-CD2 BOOT ROM EP [S]
13	670-3119	LABEL SER. NO. SEGA-CD2 [S]	IC111	MPR-15511A	IC SEGA-CD2 USA BOOT ROM [S]
13	670-3120	LABEL SER. NO. MEGA-CD2 MULTI [M]	IC111	EPR-15512	IC MEGA-CD2 BOOT EP MULTI [M]
14	670-0248	SEAL CUSTOMER SERVICE [S]	IC111	MPR-15512A	IC MEGA-CD2 (PAL) BOOT ROM [M]
14	670-2774	LABEL CAUTION LASER EUROPE [M]	IC112	315-0635	IC MB8464A-10LL PF-G-BND FUJITSU
14	670-3349	LABEL CUSTOMER SERVICE SOC [S]	IC113	315-0637	IC MC68HC000FN12 PLCC MOTOROLA
15	670-3204	LABEL FCC SEGA-CD2 USA [S]	IC113	315-0650	IC HD68HC000CP-12 PLCC HITACHI
15	670-3417	LABEL FCC SEGA-CD2 CAN [S]	IC113	315-0626	IC TMP68HC000T-12 PLCC TOSHIBA
16	670-3126-01	LABEL FDA MK-4101 USA [S]	IC114	313-5190	IC MB3790 SOP 16PIN FUJITSU
16	670-2708	SEAL RFI MARK MEGA-CD MULTI [M]	IC116	314-0549-01	IC TC74HC86 SOP TOSHIBA
17	670-3209	CAUTION LABEL SEGA-CD2 [S]	IC201	313-5184	IC LC7883KM SOP SANYO
17	670-3210	CAUTION LABEL MEGA-CD2 MULTI [M]	IC202	313-5231	IC LC78815M SOP 20P SANYO
201	012-P00310	TAP SCR PH M3x10	IC203	313-5249	IC NJM3403AM SOP
202	012-P00308	TAP SCR PH M3x8	IC204	313-5249	IC NJM3403AM SOP
			IC205	313-5250	IC NJM3404AM SOP
			IC301	313-5193	IC UPC2405HF NEC
			IC401	315-0798	IC CXD1167Q QFP
			IC402	313-5251	IC CXA1081M SOP
			IC403	313-5252	IC CXA1082Q QFP
			IC404	315-0799	IC UPD75P008GB QFP
			IC404	315-0808	IC UPD75006GB QFP
			IC407	314-0571	IC 74HC04 SOP
			IC408	313-5253	IC TC4566F-TE85R
			IC409	314-0572	IC AN8388SR SOP
			IC409	314-0585	IC AN8388NSRBE1 SOP
			IC601	314-0573	IC PST529F MMP3P RESET IC
			X 101	230-5103	XTAL OSC 50.000MHZ JX0-7
			X 401	230-5104	XTAL OSC 16.9344MHZ HC-49U
			X 702	230-5109	CER OSC 4.19MHZ
			Q 101	482-5191	XSTR CHIP 2SC2812-5-CP-TB
			Q 101	482-5192	XSTR CHIP 2SC2812-6-CP-TB
			Q 201	482-5191	XSTR CHIP 2SC2812-5-CP-TB
			Q 201	482-5192	XSTR CHIP 2SC2812-6-CP-TB
			Q 202	482-5191	XSTR CHIP 2SC2812-5-CP-TB
			Q 202	482-5192	XSTR CHIP 2SC2812-6-CP-TB

Note: [S] → SEGA CD II  
[M] → MEGA CD II

Circuit No.	Parts No.	Description		Circuit No.	Parts No.	Description	
Q 301	482-5193	XSTR 2S8963 M		R 220	476-1472-J-16	RES CHIP 4.7kOHM 1/16W 5%	
Q 301	482-5194	XSTR 2S8963 L		R 221	476-1472-J-16	RES CHIP 4.7kOHM 1/16W 5%	
Q 301	482-5195	XSTR 2S8963 K		R 222	476-1472-J-16	RES CHIP 4.7kOHM 1/16W 5%	
Q 302	482-5191	XSTR CHIP 2SC2812-5-CP-TB	[S]	R 223	476-1222-J-16	RES CHIP 2.2kOHM 1/16W 5%	
Q 302	482-5192	XSTR CHIP 2SC2812-6-CP-TB	[S]	R 224	476-1331-J-16	RES CHIP 330 OHM 1/16W 5%	
Q 302	482-5204	XSTR CHIP 2SC4362	[M]	R 225	476-1222-J-16	RES CHIP 2.2kOHM 1/16W 5%	
Q 302	482-5205	XSTR CHIP UN221L	[M]	R 226	476-1331-J-16	RES CHIP 330 OHM 1/16W 5%	
Q 401	482-5196	XSTR 2SA1704 S-AN		R 227	476-1750-J-16	RES CHIP 750HM 1/16W 5%	
Q 401	482-5197	XSTR 2SA1704 T-AN		R 228	476-1472-J-16	RES CHIP 4.7kOHM 1/16W 5%	
Q 402	482-5191	XSTR CHIP 2SC2812-5-CP-TB		R 229	476-1750-J-16	RES CHIP 750HM 1/16W 5%	
Q 402	482-5192	XSTR CHIP 2SC2812-6-CP-TB		R 230	476-1472-J-16	RES CHIP 4.7kOHM 1/16W 5%	
BT101	401-0037	BATTERY ML2016-HS1 SANYO		R 231	476-1472-J-16	RES CHIP 4.7kOHM 1/16W 5%	
D 301	481-5119	DIODE DSK10-ET1		R 232	476-1472-J-16	RES CHIP 4.7kOHM 1/16W 5%	
D 302	481-5121	DIODE GMB01-BT	[M]	R 233	476-1472-J-16	RES CHIP 4.7kOHM 1/16W 5%	
D 401	481-5120	DIODE IS2076RE		R 234	476-1472-J-16	RES CHIP 4.7kOHM 1/16W 5%	
D 601	481-5121	DIODE GMB01-BT		R 235	476-1331-J-16	RES CHIP 330 OHM 1/16W 5%	
LO101	390-5449	LED LN88RPX		R 236	476-1331-J-16	RES CHIP 330 OHM 1/16W 5%	
FLT505	271-0058	FILMAC TH30333MAT		R 237	476-1472-J-16	RES CHIP 4.7kOHM 1/16W 5%	
FLT506	479-5009	RES 0 OHM 1/4W		R 238	476-1332-J-16	RES CHIP 3.3kOHM 1/16W 5%	
FLT507	479-5009	RES 0 OHM 1/4W		R 239	476-1332-J-16	RES CHIP 3.3kOHM 1/16W 5%	
FLT512	271-0058	FILMAC TH30333MAT		R 240	476-1332-J-16	RES CHIP 3.3kOHM 1/16W 5%	
FLT516	479-5009	RES 0 OHM 1/4W		R 241	476-1750-J-16	RES CHIP 750HM 1/16W 5%	
FLT519	479-5009	RES 0 OHM 1/4W		R 242	476-1750-J-16	RES CHIP 750HM 1/16W 5%	
FLT520	479-5009	RES 0 OHM 1/4W		R 243	476-1152-J-16	RES CHIP 1.5kOHM 1/16W 5%	
FLT522	479-5009	RES 0 OHM 1/4W		R 244	476-1122-J-16	RES CHIP 1.2kOHM 1/16W 5%	
FLT600	479-5009	RES 0 OHM 1/4W		R 301	476-1472-J-16	RES CHIP 4.7kOHM 1/16W 5%	[S]
FLT601	271-0059	FILMAC TX09500NBT		R 301	476-1822-J-16	RES CHIP 8.2kOHM 1/16W 5%	[M]
FLT602	271-0060	FILMAC TX07520NBT		R 302	476-1162-J-16	RES CHIP 1.6kOHM 1/16W 5%	[S]
FLT604	479-5009	RES 0 OHM 1/4W		R 302	NOT USED	NOT USED	[M]
EMI202	271-0007	EMI FILTER STX222MB		R 303	476-1162-J-16	RES CHIP 1.6kOHM 1/16W 5%	
EMI202	479-5009	RES 0 OHM 1/4W		R 304	476-1472-J-16	RES CHIP 4.7kOHM 1/16W 5%	
EMI203	271-0007	EMI FILTER STX222MB		R 401	476-1102-J-16	RES CHIP 1kOHM 1/16W 5%	
EMI203	479-5009	RES 0 OHM 1/4W		R 402	476-2100-J-10	RES CHIP 10 OHM 1/10W 5%	
EMI204	479-5009	RES 0 OHM 1/4W		R 403	476-1103-J-16	RES CHIP 10kOHM 1/16W 5%	
EMI205	479-5009	RES 0 OHM 1/4W		R 404	476-1153-J-16	RES CHIP 15kOHM 1/16W 5%	
EMI206	479-5009	RES 0 OHM 1/4W		R 405	476-1102-J-16	RES CHIP 1kOHM 1/16W 5%	
FL301	271-0054	LINE FILTER CM08RB01		R 406	476-1104-J-16	RES CHIP 100kOHM 1/16W 5%	
F 301	514-5044	FUSE PICO II 25202.5 RADIAL		R 407	476-1103-J-16	RES CHIP 10kOHM 1/16W 5%	
R 101	476-1361-J-16	RES CHIP 360 OHM 1/16W 5%		R 408	476-1223-J-16	RES CHIP 22kOHM 1/16W 5%	
R 102	476-1472-J-16	RES CHIP 4.7kOHM 1/16W 5%		R 409	476-1223-J-16	RES CHIP 22kOHM 1/16W 5%	
R 103	476-1222-J-16	RES CHIP 2.2kOHM 1/16W 5%		R 410	476-1101-J-16	RES CHIP 100 OHM 1/16W 5%	
R 104	476-1473-J-16	RES CHIP 47kOHM 1/16W 5%		R 411	476-1101-J-16	RES CHIP 100 OHM 1/16W 5%	
R 105	476-1472-J-16	RES CHIP 4.7kOHM 1/16W 5%		R 412	476-1222-J-16	RES CHIP 2.2kOHM 1/16W 5%	
R 106	476-1472-J-16	RES CHIP 4.7kOHM 1/16W 5%		R 413	476-1103-J-16	RES CHIP 10kOHM 1/16W 5%	
R 107	479-5007-J-16	RES CHIP 0 OHM 1/16W J		R 414	476-1182-J-16	RES CHIP 1.8kOHM 1/16W 5%	
R 108	479-5007-J-16	RES CHIP 0 OHM 1/16W J		R 415	476-1223-J-16	RES CHIP 22kOHM 1/16W 5%	
R 109	479-5007-J-16	RES CHIP 0 OHM 1/16W J		R 416	476-1334-J-16	RES CHIP 330kOHM 1/16W 5%	
R 130	479-5007-J-16	RES CHIP 0 OHM 1/16W J		R 417	151-0421	CAP CER CHIP 4700PF/50V B K	
R 131	479-5007-J-16	RES CHIP 0 OHM 1/16W J		R 418	479-5007-J-16	RES CHIP 0 OHM 1/16W J	
R 201	476-1162-J-16	RES CHIP 1.6k OHM 1/16W 5%		R 419	476-1184-J-16	RES CHIP 180kOHM 1/16W 5%	
R 202	476-1102-J-16	RES CHIP 1kOHM 1/16W 5%		R 420	476-1334-J-16	RES CHIP 330kOHM 1/16W 5%	
R 203	476-1472-J-16	RES CHIP 4.7kOHM 1/16W 5%		R 421	476-1224-J-16	RES CHIP 220kOHM 1/16W 5%	
R 204	476-1472-J-16	RES CHIP 4.7kOHM 1/16W 5%		R 422	476-1154-J-16	RES CHIP 150kOHM 1/16W 5%	
R 205	476-1472-J-16	RES CHIP 4.7kOHM 1/16W 5%		R 423	476-1224-J-16	RES CHIP 220kOHM 1/16W 5%	
R 206	476-1472-J-16	RES CHIP 4.7kOHM 1/16W 5%		R 424	476-1153-J-16	RES CHIP 15kOHM 1/16W 5%	
R 207	476-1472-J-16	RES CHIP 4.7kOHM 1/16W 5%		R 425	476-1393-J-16	RES CHIP 39kOHM 1/16W 5%	
R 208	476-1222-J-16	RES CHIP 2.2kOHM 1/16W 5%		R 426	476-1472-J-16	RES CHIP 4.7kOHM 1/16W 5%	
R 209	476-1222-J-16	RES CHIP 2.2kOHM 1/16W 5%		R 427	476-1334-J-16	RES CHIP 330kOHM 1/16W 5%	
R 210	476-1472-J-16	RES CHIP 4.7kOHM 1/16W 5%		R 428	476-1514-J-16	RES CHIP 510kOHM 1/16W 5%	
R 211	476-1222-J-16	RES CHIP 2.2kOHM 1/16W 5%		R 429	476-1103-J-16	RES CHIP 10kOHM 1/16W 5%	
R 212	476-1222-J-16	RES CHIP 2.2kOHM 1/16W 5%		R 430	476-1224-J-16	RES CHIP 220kOHM 1/16W 5%	
R 213	476-1472-J-16	RES CHIP 4.7kOHM 1/16W 5%		R 431	476-1332-J-16	RES CHIP 3.3kOHM 1/16W 5%	
R 214	476-1472-J-16	RES CHIP 4.7kOHM 1/16W 5%		R 432	476-1823-J-16	RES CHIP 82kOHM 1/16W 5%	
R 215	476-1331-J-16	RES CHIP 330 OHM 1/16W 5%		R 433	476-1105-J-16	RES CHIP 1MOHM 1/16W 5%	
R 216	476-1100-J-16	RES CHIP 10 OHM 1/16W 5%		R 434	476-1223-J-16	RES CHIP 22kOHM 1/16W 5%	
R 217	476-1331-J-16	RES CHIP 330 OHM 1/16W 5%		R 435	476-1104-J-16	RES CHIP 100kOHM 1/16W 5%	
R 218	476-1100-J-16	RES CHIP 10 OHM 1/16W 5%		R 436	476-1104-J-16	RES CHIP 100kOHM 1/16W 5%	
R 219	476-1472-J-16	RES CHIP 4.7kOHM 1/16W 5%		R 437	476-1104-J-16	RES CHIP 100kOHM 1/16W 5%	
R 220	476-1472-J-16	RES CHIP 4.7kOHM 1/16W 5%		R 438	476-1103-J-16	RES CHIP 10kOHM 1/16W 5%	
R 221	476-1472-J-16	RES CHIP 4.7kOHM 1/16W 5%		R 441	479-5007-J-16	RES CHIP 0 OHM 1/16W J	
R 222	476-1472-J-16	RES CHIP 4.7kOHM 1/16W 5%		R 444	476-2100-J-10	RES CHIP 10 OHM 1/10W 5%	
R 223	476-1222-J-16	RES CHIP 2.2kOHM 1/16W 5%		R 445	476-1101-J-16	RES CHIP 100 OHM 1/16W 5%	
R 224	476-1331-J-16	RES CHIP 330 OHM 1/16W 5%		R 446	476-1101-J-16	RES CHIP 100 OHM 1/16W 5%	
R 225	476-1222-J-16	RES CHIP 2.2kOHM 1/16W 5%		R 447	479-5007-J-16	RES CHIP 0 OHM 1/16W J	
R 226	476-1331-J-16	RES CHIP 330 OHM 1/16W 5%		R 448	476-1910-J-16	RES CHIP 910HM 1/16W 5%	
R 227	476-1750-J-16	RES CHIP 750HM 1/16W 5%		R 449	476-1103-J-16	RES CHIP 10kOHM 1/16W 5%	
R 228	476-1472-J-16	RES CHIP 4.7kOHM 1/16W 5%					
R 229	476-1750-J-16	RES CHIP 750HM 1/16W 5%					
R 230	476-1472-J-16	RES CHIP 4.7kOHM 1/16W 5%					
R 231	476-1472-J-16	RES CHIP 4.7kOHM 1/16W 5%					
R 232	476-1472-J-16	RES CHIP 4.7kOHM 1/16W 5%					
R 233	476-1472-J-16	RES CHIP 4.7kOHM 1/16W 5%					
R 234	476-1472-J-16	RES CHIP 4.7kOHM 1/16W 5%					
R 235	476-1331-J-16	RES CHIP 330 OHM 1/16W 5%					
R 236	476-1331-J-16	RES CHIP 330 OHM 1/16W 5%					
R 237	476-1472-J-16	RES CHIP 4.7kOHM 1/16W 5%					
R 238	476-1332-J-16	RES CHIP 3.3kOHM 1/16W 5%					
R 239	476-1332-J-16	RES CHIP 3.3kOHM 1/16W 5%					
R 240	476-1332-J-16	RES CHIP 3.3kOHM 1/16W 5%					
R 241	476-1750-J-16	RES CHIP 750HM 1/16W 5%					
R 242	476-1750-J-16	RES CHIP 750HM 1/16W 5%					
R 243	476-1152-J-16	RES CHIP 1.5kOHM 1/16W 5%					
R 244	476-1122-J-16	RES CHIP 1.2kOHM 1/16W 5%					
R 301	476-1472-J-16	RES CHIP 4.7kOHM 1/16W 5%					
R 301	476-1822-J-16	RES CHIP 8.2kOHM 1/16W 5%					
R 302	476-1162-J-16	RES CHIP 1.6kOHM 1/16W 5%					
R 302	NOT USED	NOT USED					
R 303	476-1162-J-16	RES CHIP 1.6kOHM 1/16W 5%					
R 304	476-1472-J-16	RES CHIP 4.7kOHM 1/16W 5%					
R 401	476-1102-J-16	RES CHIP 1kOHM 1/16W 5%					
R 402	476-2100-J-10	RES CHIP 10 OHM 1/10W 5%					
R 403	476-1103-J-16	RES CHIP 10kOHM 1/16W 5%					
R 404	476-1153-J-16	RES CHIP 15kOHM 1/16W 5%					
R 405	476-1102-J-16	RES CHIP 1kOHM 1/16W 5%					
R 406	476-1104-J-16	RES CHIP 100kOHM 1/16W 5%					
R 407	476-1103-J-16	RES CHIP 10kOHM 1/16W 5%					
R 408	476-1223-J-16	RES CHIP 22kOHM 1/16W 5%					
R 409	476-1223-J-16	RES CHIP 22kOHM 1/16W 5%					
R 410	476-1101-J-16	RES CHIP 100 OHM 1/16W 5%					
R 411	476-1101-J-16	RES CHIP 100 OHM 1/16W 5%					
R 412	476-1222-J-16	RES CHIP 2.2kOHM 1/16W 5%					
R 413	476-1103-J-16	RES CHIP 10kOHM 1/16W 5%					
R 414	476-1182-J-16	RES CHIP 1.8kOHM 1/16W 5%					
R 415	476-1223-J-16	RES CHIP 22kOHM 1/16W 5%					
R 416	476-1334-J-16	RES CHIP 330kOHM 1/16W 5%					
R 417	151-0421	CAP CER CHIP 4700PF/50V B K					
R 418	479-5007-J-16	RES CHIP 0 OHM 1/16W J					
R 419	476-1184-J-16	RES CHIP 180kOHM 1/16W 5%					
R 420	476-1334-J-16	RES CHIP 330kOHM 1/16W 5%					
R 421	476-1224-J-16	RES CHIP 220kOHM 1/16W 5%					
R 422	476-1154-J-16	RES CHIP 150kOHM 1/16W 5%					
R 423	476-1224-J-16	RES CHIP 220kOHM 1/16W 5%					

Circuit No.	Parts No.	Description	Circuit No.	Parts No.	Description
R 450	476-1333-J-16	RES CHIP 33kOHM 1/16W 5%	VR403	475-0075	V. RES C TRM 2kOHM B RADIAL
R 451	476-1474-J-16	RES CHIP 470kOHM 1/16W 5%			
R 452	476-1103-J-16	RES CHIP 10kOHM 1/16W 5%	RA101	477-0152	RES PACK CP 8×4. 7kOHM W/COMM
R 454	476-2100-J-10	RES CHIP 10 OHM 1/10W 5%	RA102	477-0152	RES PACK CP 8×4. 7kOHM W/COMM
R 456	476-2100-J-10	RES CHIP 10 OHM 1/10W 5%			
R 465	476-2100-J-10	RES CHIP 10 OHM 1/10W 5%	C 001	151-0434	CAP CER CP 0.1UF/0.5V F Z
R 468	476-1103-J-16	RES CHIP 10kOHM 1/16W 5%	C 104	150-0439	CAP E 10UF/16V 20%
R 469	476-1103-J-16	RES CHIP 10kOHM 1/16W 5%	C 105	151-0405	CAP CER CP 0.1UF/16V F Z
R 470	476-1103-J-16	RES CHIP 10kOHM 1/16W 5%	C 109	151-0405	CAP CER CP 0.1UF/16V F Z
R 471	476-1103-J-16	RES CHIP 10kOHM 1/16W 5%	C 110	150-0439	CAP E 10UF/16V 20%
R 472	476-1103-J-16	RES CHIP 10kOHM 1/16W 5%	C 113	151-0406	CAP CER CP 100PF/50V SL J
R 473	476-1103-J-16	RES CHIP 10kOHM 1/16W 5%	C 114	151-0405	CAP CER CP 0.1UF/16V F Z
R 474	476-1473-J-16	RES CHIP 47kOHM 1/16W 5%	C 115	150-0439	CAP E 10UF/16V 20%
R 476	476-1103-J-16	RES CHIP 10kOHM 1/16W 5%	C 118	151-0406	CAP CER CP 100PF/50V SL J
R 477	476-1103-J-16	RES CHIP 10kOHM 1/16W 5%	C 119	151-0405	CAP CER CP 0.1UF/16V F Z
R 478	476-1103-J-16	RES CHIP 10kOHM 1/16W 5%	C 120	151-0405	CAP CER CP 0.1UF/16V F Z
R 479	476-1103-J-16	RES CHIP 10kOHM 1/16W 5%	C 122	150-0439	CAP E 10UF/16V 20%
R 480	476-1103-J-16	RES CHIP 10kOHM 1/16W 5%	C 126	151-0405	CAP CER CP 0.1UF/16V F Z
R 481	476-1103-J-16	RES CHIP 10kOHM 1/16W 5%	C 127	150-0439	CAP E 10UF/16V 20%
R 482	476-1103-J-16	RES CHIP 10kOHM 1/16W 5%	C 128	151-0405	CAP CER CP 0.1UF/16V F Z
R 483	476-1103-J-16	RES CHIP 10kOHM 1/16W 5%	C 129	150-0439	CAP E 10UF/16V 20%
R 484	476-1103-J-16	RES CHIP 10kOHM 1/16W 5%	C 130	151-0405	CAP CER CP 0.1UF/16V F Z
R 485	476-1103-J-16	RES CHIP 10kOHM 1/16W 5%	C 131	150-0439	CAP E 10UF/16V 20%
R 486	479-5007-J-16	RES CHIP 0 OHM 1/16W J	C 132	150-0439	CAP E 10UF/16V 20%
R 487	476-1103-J-16	RES CHIP 10kOHM 1/16W 5%	C 133	151-0405	CAP CER CP 0.1UF/16V F Z
R 488	476-1683-J-16	RES CHIP 68kOHM 1/16W 5%	C 135	151-0405	CAP CER CP 0.1UF/16V F Z
R 489	476-1473-J-16	RES CHIP 47kOHM 1/16W 5%	C 137	151-0405	CAP CER CP 0.1UF/16V F Z
R 490	476-1333-J-16	RES CHIP 33kOHM 1/16W 5%	C 138	151-0405	CAP CER CP 0.1UF/16V F Z
R 490	476-1473-J-16	RES CHIP 47kOHM 1/16W 5%	C 139	150-0439	CAP E 10UF/16V 20%
R 491	476-1683-J-16	RES CHIP 68kOHM 1/16W 5%	C 143	151-0409	CAP CER CP 1000PF/50V B K
R 492	476-2100-J-10	RES CHIP 10 OHM 1/10W 5%	C 144	151-0405	CAP CER CP 0.1UF/16V F Z
R 493	476-2100-J-10	RES CHIP 10 OHM 1/10W 5%			
R 494	476-2100-J-10	RES CHIP 10 OHM 1/10W 5%	C 201	150-0440	CAP E 100UF/6.3V 20%
R 495	476-2100-J-10	RES CHIP 10 OHM 1/10W 5%	C 206	150-0439	CAP E 10UF/16V 20%
R 496	476-1103-J-16	RES CHIP 10kOHM 1/16W 5%	C 207	150-0439	CAP E 10UF/16V 20%
R 497	476-1103-J-16	RES CHIP 10kOHM 1/16W 5%	C 208	150-0439	CAP E 10UF/16V 20%
R 498	476-1103-J-16	RES CHIP 10kOHM 1/16W 5%	C 209	150-0439	CAP E 10UF/16V 20%
R 601	476-1102-J-16	RES CHIP 1kOHM 1/16W 5%	C 210	150-0439	CAP E 10UF/16V 20%
R 602	476-1104-J-16	RES CHIP 100kOHM 1/16W 5%	C 211	151-0410	CAP CER CP 680PF/50V B K
			C 212	151-0410	CAP CER CP 680PF/50V B K
R 701	479-5007-J-16	RES CHIP 0 OHM 1/16W 5%	C 213	151-0405	CAP CER CP 0.1UF/16V F Z
R 702	476-1330-J-16	RES CHIP 33 OHM 1/16W 5%	C 214	151-0411	CAP CER CP 8200PF/50V B K
R 703	476-1330-J-16	RES CHIP 33 OHM 1/16W 5%	C 215	151-0411	CAP CER CP 8200PF/50V B K
R 704	476-1330-J-16	RES CHIP 33 OHM 1/16W 5%	C 216	151-0405	CAP CER CP 0.1UF/16V F Z
R 705	476-1330-J-16	RES CHIP 33 OHM 1/16W 5%	C 217	151-0412	CAP CER CP 1200PF/50V B K
R 706	476-1330-J-16	RES CHIP 33 OHM 1/16W 5%	C 218	151-0412	CAP CER CP 1200PF/50V B K
R 707	476-1330-J-16	RES CHIP 33 OHM 1/16W 5%	C 219	151-0405	CAP CER CP 0.1UF/16V F Z
R 708	476-1330-J-16	RES CHIP 33 OHM 1/16W 5%	C 220	150-0439	CAP E 10UF/16V 20%
R 709	476-1330-J-16	RES CHIP 33 OHM 1/16W 5%	C 221	150-0439	CAP E 10UF/16V 20%
R 710	476-1330-J-16	RES CHIP 33 OHM 1/16W 5%	C 222	150-0439	CAP E 10UF/16V 20%
R 711	476-1330-J-16	RES CHIP 33 OHM 1/16W 5%	C 223	151-0413	CAP CER CP 2200PF/50V B K
R 712	476-1330-J-16	RES CHIP 33 OHM 1/16W 5%	C 224	151-0405	CAP CER CP 0.1UF/16V F Z
R 713	476-1330-J-16	RES CHIP 33 OHM 1/16W 5%	C 225	151-0411	CAP CER CP 8200PF/50V B K
R 714	476-1330-J-16	RES CHIP 33 OHM 1/16W 5%	C 226	151-0413	CAP CER CP 2200PF/50V B K
R 715	476-1330-J-16	RES CHIP 33 OHM 1/16W 5%	C 227	151-0411	CAP CER CP 8200PF/50V B K
R 716	476-1330-J-16	RES CHIP 33 OHM 1/16W 5%	C 228	150-0439	CAP E 10UF/16V 20%
R 717	476-1330-J-16	RES CHIP 33 OHM 1/16W 5%	C 229	150-0439	CAP E 10UF/16V 20%
R 718	479-5007-J-16	RES CHIP 0 OHM 1/16W	C 230	151-0411	CAP CER CP 8200PF/50V B K
			C 231	151-0411	CAP CER CP 8200PF/50V B K
R 802	479-5007-J-16	RES CHIP 0 OHM 1/16W	C 232	150-0439	CAP E 10UF/16V 20%
			C 233	150-0439	CAP E 10UF/16V 20%
RB101	476-1221-J-16	RES CHIP 220 OHM 1/16W 5%	C 234	150-0439	CAP E 10UF/16V 20%
RB102	476-1221-J-16	RES CHIP 220 OHM 1/16W 5%	C 235	150-0439	CAP E 10UF/16V 20%
RB103	476-1221-J-16	RES CHIP 220 OHM 1/16W 5%	C 236	150-0439	CAP E 10UF/16V 20%
RB104	476-1221-J-16	RES CHIP 220 OHM 1/16W 5%	C 237	150-0439	CAP E 10UF/16V 20%
RB105	476-1221-J-16	RES CHIP 220 OHM 1/16W 5%	C 238	150-0440	CAP E 100UF/6.3V 20%
RB106	476-1221-J-16	RES CHIP 220 OHM 1/16W 5%	C 239	150-0439	CAP E 10UF/16V 20%
RB107	476-1221-J-16	RES CHIP 220 OHM 1/16W 5%	C 240	150-0439	CAP E 10UF/16V 20%
RB108	476-1221-J-16	RES CHIP 220 OHM 1/16W 5%			
RB109	476-1221-J-16	RES CHIP 220 OHM 1/16W 5%	C 301	150-0440	CAP E 100UF/6.3V 20%
RB110	476-1221-J-16	RES CHIP 220 OHM 1/16W 5%	C 302	151-0405	CAP CER CP 0.1UF/16V F Z
RB111	476-1221-J-16	RES CHIP 220 OHM 1/16W 5%	C 303	150-0441	CAP E 1000UF/6.3V 20%
RB112	476-1221-J-16	RES CHIP 220 OHM 1/16W 5%	C 304	151-0405	CAP CER CP 0.1UF/16V F Z
RB113	476-1221-J-16	RES CHIP 220 OHM 1/16W 5%	C 305	150-0249	CAP E 330UF 16V U-TYPE
RB114	476-1221-J-16	RES CHIP 220 OHM 1/16W 5%	C 306	150-0440	CAP E 100UF/6.3V 20%
RB115	476-1221-J-16	RES CHIP 220 OHM 1/16W 5%			
RB116	476-1221-J-16	RES CHIP 220 OHM 1/16W 5%	C 401	151-0456	CAP CER CP 0.33UF/16V R K
VR401	475-0073	V. RES C TRM 20kOHM B RADIAL	C 403	150-0249	CAP E 330UF 16V U-TYPE
VR402	475-0074	V. RES C TRM 5kOHM B RADIAL	C 404	150-0440	CAP E 100UF/6.3V 20%
			C 406	150-0301	CAP E 470UF/6.3V U-TYPE

Note: [S] → SEGA CD II  
[M] → MEGA CD II

Note: All chip resistors and capacitors are 1.6 × 0.8 mm.

Circuit No.	Parts No.	Description	Circuit No.	Parts No.	Description		
C 407	150-0329	CAP E 3.3UF 50V U-TYPE	CN406	212-5281	CONN E8G-701B-00		
C 408	150-0440	CAP E 100UF/6.3V 20%	SW401	510-5050	LEAF SW LSA-1141E2AU		
C 409	150-0440	CAP E 100UF/6.3V 20%		250-5342	SW COVER CD2 SY (FOR SW401)		
C 410	150-0442	CAP E 0.47UF/50V 20%	<b>13-4. Accessories/Package List</b>				
C 411	150-0443	CAP E 22UF/6.3V 20%					
C 412	150-0443	CAP E 22UF/6.3V 20%	No.	Parts No.	Description		
C 413	150-0016	CAP E 1UF 50V	1	610-5507	ASSY CD ROM MDP ROAD AVENGER [M]		
C 414	150-0442	CAP E 0.47UF/50V 20%	1	610-5574	ASSY CD ROM GEN W/SEWER SHARK [S]		
C 415	151-0415	CAP CER CP 3900PF/50V B K	2	400-5100B	AC ADAPTOR AC120V/DC10V 1.2A [S]		
C 416	151-0416	CAP CER CP 5PF/50V CH C	2	400-5100B-01	AC ADAPTOR AC120V/DC10V 1.2A [S]		
C 417	151-0417	CAP CER CP 0.033UF/50V B K	2	400-5122C	AC ADAPTOR AC230V/DC10V 1.2A (EXCEPT U. K, KUWAIT, AUSTRALIA & NEWZEALAND) [M]		
C 418	151-0419	CAP CER CP 0.1UF/50V B K	2	400-5127A	AC ADAPTOR AC240V/DC10V 1.2A (FOR U. K, KUWAIT) [M]		
C 419	151-0417	CAP CER CP 0.033UF/50V B K	2	400-5128A	AC ADAPTOR AC240V/DC10V 1.2A (FOR AUSTRALIA & NEWZEALAND) [M]		
C 420	151-0419	CAP CER CP 0.1UF/50V B K	3	600-6201	STEREO MIXING CABLE W/CORE		
C 421	151-0419	CAP CER CP 0.1UF/50V B K	4	600-6204	AUDIO RCA CABLE L=2M UNION [M]		
C 422	479-5007-J-16	RES CHIP 0 OHM 1/16W J	5	610-5491	ASSY SPACER MEGA-CD2 EXPORT		
C 423	151-0413	CAP CER CP 2200PF/50V B K	6	250-5346	HOLD PLATE SPACER MEGA-CD2 A		
C 424	151-0419	CAP CER CP 0.1UF/50V B K	7	250-5333	RETAINER BRACKET CD2 EXPORT		
C 425	151-0417	CAP CER CP 0.033UF/50V B K	8	250-5329	CONN PLATE A ACCESSORY CD2 EXP		
C 426	151-0417	CAP CER CP 0.033UF/50V B K	9	250-5330	CONN PLATE B ACCESSORY CD2 EXP		
C 427	151-0419	CAP CER CP 0.1UF/50V B K	10	000-F00410	M SCR FH M4x10		
C 428	151-0420	CAP CER CP 0.056UF/50V B K	11	671-3240-01E	MA CTN SEGA-CD2 USA E (FOR MK-4101) [S]		
C 429	151-0419	CAP CER CP 0.1UF/50V B K	11	671-3240-03	MA CTN MEGA-CD2 MULTI 4180 (FOR MK-4180) [M]		
C 430	151-0421	CAP CER CHIP 4700PF/50V B K	11	671-3240-05	MA CTN SEGA-CD2 CAN 4101-22 (FOR MK-4101-22) [S]		
C 431	151-0409	CAP CER CP 1000PF/50V B K	11	671-3240-06	MA CTN MEGA-CD2 MULTI 4182 (FOR MK-4182) [M]		
C 432	151-0417	CAP CER CP 0.033UF/50V B K	12	672-1257	OPERATION MANUAL CD2 USA [S]		
C 433	151-0405	CAP CER CP 0.1UF/16V F Z	12	672-1332	OPERATION MANUAL CD2 CANADA [S]		
C 434	151-0422	CAP CER CP 24PF/50V CH J	12	672-1258-01	OPERATION MANUAL CD2 MULTI 01 [M]		
C 435	151-0422	CAP CER CP 24PF/50V CH J	13	671-3322-01	BOX & PACK SET CD2 USA (FOR MK-4101) [S]		
C 436	151-0422	CAP CER CP 24PF/50V CH J	13	671-3322-05	BOX & PACK SET CD2 CAN 4101-22 (FOR MK-4101-22) [S]		
C 437	151-0405	CAP CER CP 0.1UF/16V F Z	13	671-3322-03	BOX & PACK SET CD2 MULTI 4180 (FOR MK-4180) [M]		
C 438	151-0405	CAP CER CP 0.1UF/16V F Z	13	671-3322-06	BOX & PACK SET CD2 MULTI 4182 (FOR MK-4182) [M]		
C 439	151-0405	CAP CER CP 0.1UF/16V F Z	14	670-3211	BUSINESS REPLY MAIL CD2 USA [S]		
C 440	151-0405	CAP CER CP 0.1UF/16V F Z	14	670-4106	BUSINESS REPLY MAIL SOC [S]		
C 441	151-0405	CAP CER CP 0.1UF/16V F Z	15	670-3311	GUARANTEE CARD CD2 MULTI (EXCEPT AUSTRALIA & NEWZEALAND) [M]		
C 442	151-0405	CAP CER CP 0.1UF/16V F Z	15	670-3327	WARRANTY CARD OZ1SOFT AUS (FOR AUSTRALIA & NEWZEALAND) [M]		
C 443	151-0405	CAP CER CP 0.1UF/16V F Z	16	SGM-4218	POLY BAG 300x550x0.05 EXP6		
C 444	151-0405	CAP CER CP 0.1UF/16V F Z	17	SGM-4245	POLY BAG 200x310x0.05 EXP6		
C 445	150-0441	CAP E 1000UF/6.3V 20%	19	SGM-4207	POLY BAG 70x100x0.05		
C 446	151-0436	CAP CER CP 15PF/50V CH J	20	SGM-4220	POLY BAG 120x300x0.02		
C 447	151-0405	CAP CER CP 0.1UF/16V F Z	21	670-3265	CROSS SELL POSTER GEN2 USA [S]		
C 448	151-0405	CAP CER CP 0.1UF/16V F Z	22	672-1473-22	PLAY INSTR CDU SEWER SHARK CAN [S]		
C 449	151-0405	CAP CER CP 0.1UF/16V F Z	NOTE: Accessory Provided				
C 450	150-0441	CAP E 1000UF/6.3V 20%	Model No.	MK-4101	MK-4101-22	MK-4180	MK-4182
C 451	151-0436	CAP CER CP 15PF/50V CH J	Country	USA	Canada	Except USA & Canada	Except USA, Canada & Kuwait
C 452	151-0405	CAP CER CP 0.1UF/16V F Z	CD Soft	-	Sewer Shark	Road Avenger	-
C 453	151-0405	CAP CER CP 0.1UF/16V F Z					
C 454	151-0409	CAP CER CP 1000PF/50V B K					
C 455	150-0016	CAP E 1UF 50V					
C 601	151-0419	CAP CER CP 0.1UF/50V B K					
C 702	151-0437	CAP CER CP 150PF/50V CH J					
C 703	151-0437	CAP CER CP 150PF/50V CH J					
C 704	151-0437	CAP CER CP 150PF/50V CH J					
C 705	151-0437	CAP CER CP 150PF/50V CH J					
C 706	151-0437	CAP CER CP 150PF/50V CH J					
C 707	151-0437	CAP CER CP 150PF/50V CH J					
C 708	151-0437	CAP CER CP 150PF/50V CH J					
C 709	151-0437	CAP CER CP 150PF/50V CH J					
C 710	151-0437	CAP CER CP 150PF/50V CH J					
C 711	151-0437	CAP CER CP 150PF/50V CH J					
C 712	151-0437	CAP CER CP 150PF/50V CH J					
C 713	151-0437	CAP CER CP 150PF/50V CH J					
C 714	151-0437	CAP CER CP 150PF/50V CH J					
C 715	151-0437	CAP CER CP 150PF/50V CH J					
C 716	151-0437	CAP CER CP 150PF/50V CH J					
C 717	151-0437	CAP CER CP 150PF/50V CH J					
C 903	150-0440	CAP E 100UF/6.3V 20%					
C 920	151-0438	CAP CER CP 0.022UF/25V B K					
C 921	151-0405	CAP CER CP 0.1UF/16V F Z					
C 922	151-0439	CAP CER CP 47PF/50V CH J					
C 923	151-0439	CAP CER CP 47PF/50V CH J					
C 930	151-0405	CAP CER CP 0.1UF/16V F Z					
C 931	151-0405	CAP CER CP 0.1UF/16V F Z					
C 933	151-0405	CAP CER CP 0.1UF/16V F Z					
C 934	151-0405	CAP CER CP 0.1UF/16V F Z					
CN101	209-5068	EDGE CONN 60PIN CD2 CUSTOM					
CN201	210-5114	STEREO MINI JACK HSJ2000-01-010					
CN202	210-5115	RCA JACK YKC21-0242					
CN301	212-5378	DC JACK HEC0470-01-630					
CN403	212-5382	PIN HEADER ST 1L-S-12P-S2T2-EF					
CN404	212-5379	CONN BASE 9P B9B-PH-K-S					
CN405	212-5380	CONN BASE 8P B8B-PH-K-S					

Note: [S] → SEGA CD II  
[M] → MEGA CD II

Note: All chip resistors and capacitors are 1.6 x 0.8 mm.

**SEGA™**

# SEGA™ SERVICE MANUAL

## SEGA CD II / MEGA CD II

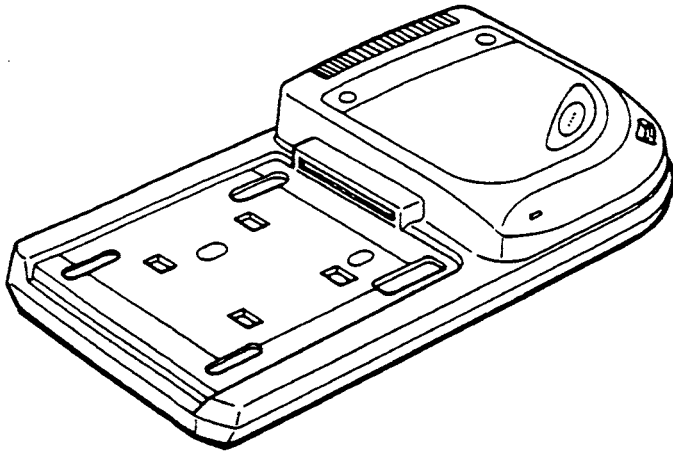

NO.	002 - 2
ISSUED	JUNE, 1994

### SUPPLEMENT

### CONTENTS

1. DIFFERENCE TABLE .....	2
2. SCHEMATIC DIAGRAM .....	3
3. CIRCUIT BOARD DIAGRAM .....	9
4. EXPLODED VIEW & PARTS LIST	
4-1. Exploded View .....	11
4-2. Mechanical Parts List .....	12
4-3. Electrical Parts List .....	12
4-4. Accessories/Package List .....	16

**Sega Enterprises, Ltd.**



# BEFORE USING THIS SERVICE MANUAL

Although the products described in the service manual (No.002) used 1.6 × 0.8mm chips (leadless) resistors and capacitors, the size has been changed to 2.0 × 1.25mm and also the pattern has been changed. Use this service manual when servicing the products with serial No.T30282001 and later.

## 1. DIFFERENCE TABLE

### 1-1. IC

Service Manual No.002				Serial No.T30282001 and later		
No.	Circuit No.	Parts No.	Description	Circuit No.	Parts No.	Description
1	IC001	314-0367	IC 74HC04	IC951	315-0853	IC TC7S04F
2	IC002	314-0407	IC 74HC74	IC952	314-0407	IC 74HC74
3	IC110	837-9798	IC BD MEGA CD2 PCM BD	Not used		

### 1-2. CD Drive Unit

1) Differences electrical parts between CD DRIVE UNIT with P/N 610-5608 and P/N 610-5603.

Circuit No.	P/N 610-5608	P/N 610-5603	Circuit No.	P/N 610-5608	P/N 610-5603
Chip Resister			Chip Capacitor		
R414	1.8 kohm	2.2 kohm	C428	0.056 $\mu$ F	Not used
R421	220 kohm	82 kohm	C451	15 pF	8 pF
R422	150 kohm	Not used	Electrolytic Capacitor		
R423	220 kohm	270 kohm	C412	22 $\mu$ F/6.3V	47 $\mu$ F/6.3V
R424	15 kohm	20 kohm			
R426	4.7 kohm	3.3 kohm			
R448	91 ohm	82 ohm			
R449	10 kohm	0 ohm			
R450	33 kohm	Not used			
R491	150 kohm	180 kohm			

2) Tracking gain adjustment value.

	P/N 610-5608	P/N 610-5603
Tracking gain adjustment value.	1 kHz/0 dB	800 Hz/0 dB

How to discriminate CD DRIVE UNIT between P/N 610-5608 and P/N 610-5603

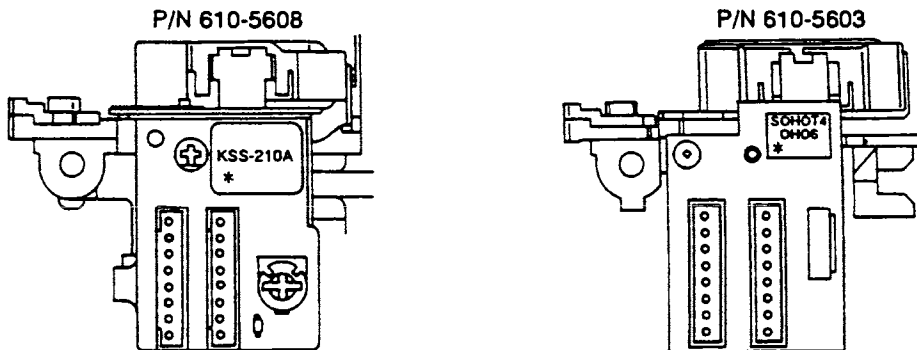

(\*) The CD DRIVE UNIT can be discriminated by checking the indication in the label pasted here.

- In case of KSS-210A .....P/N 610-5608
- In case of SOHOT4.....P/N 610-5603

Fig. 1



2-2. Schematic Diagram-2 [MEGA CD II ]

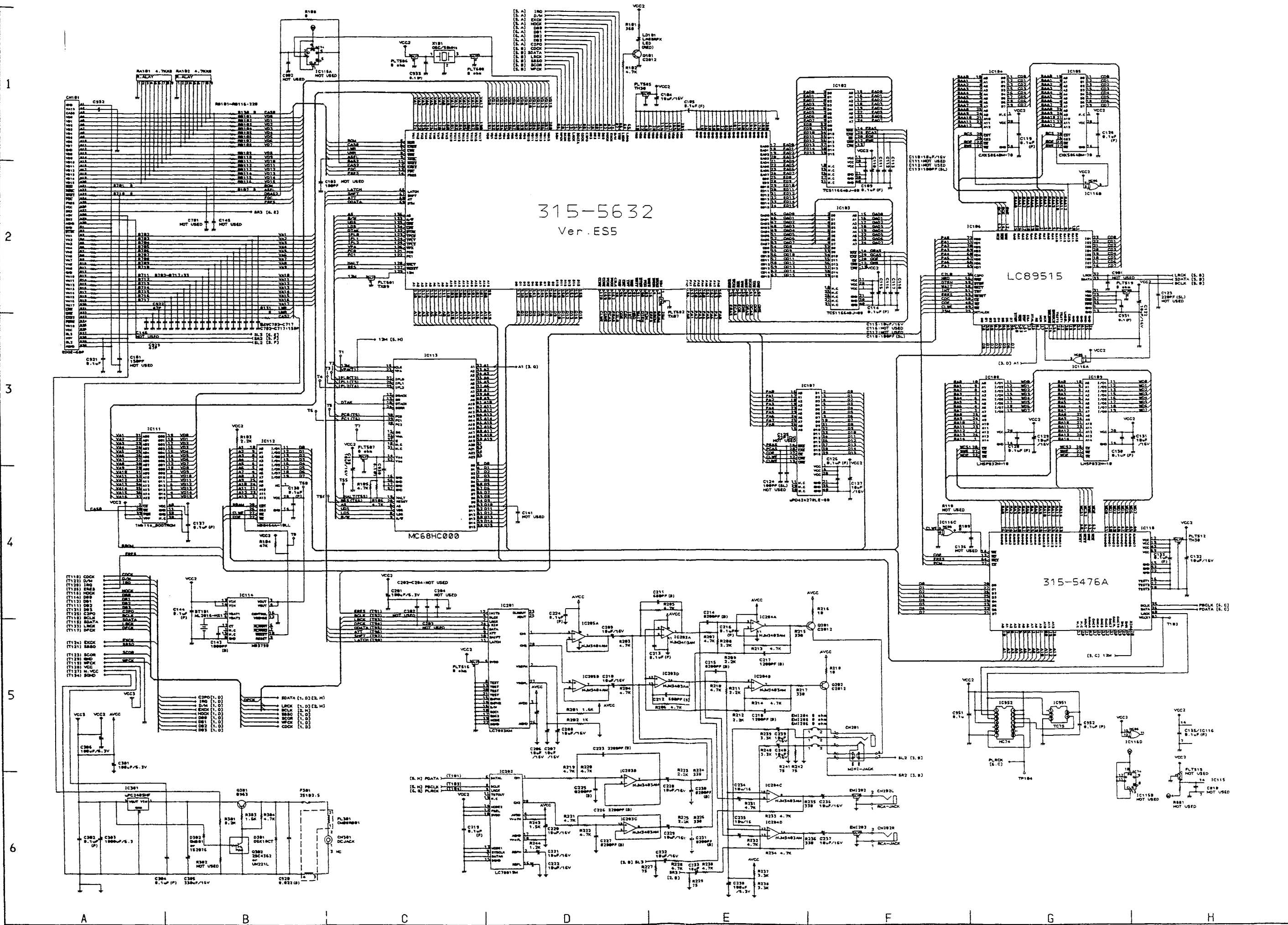

2-3. Schematic Diagram-3

Value for \* mark: Please refer to following the list.

Ref. No.	P/N 610-5608	P/N 610-5603
R414	1.8k	2.2k
R421	220k	82k
R422	150k	
R423	220k	270k
R424	15k	20k
R426	4.7k	3.3k
R448	91	82
R449	10k	0
R450	33k	
R491	150k	180k
C412	22/6.3	47/6.3
C428	0.056 $\mu$ F	
C451	15P(CH)	8P(CH)

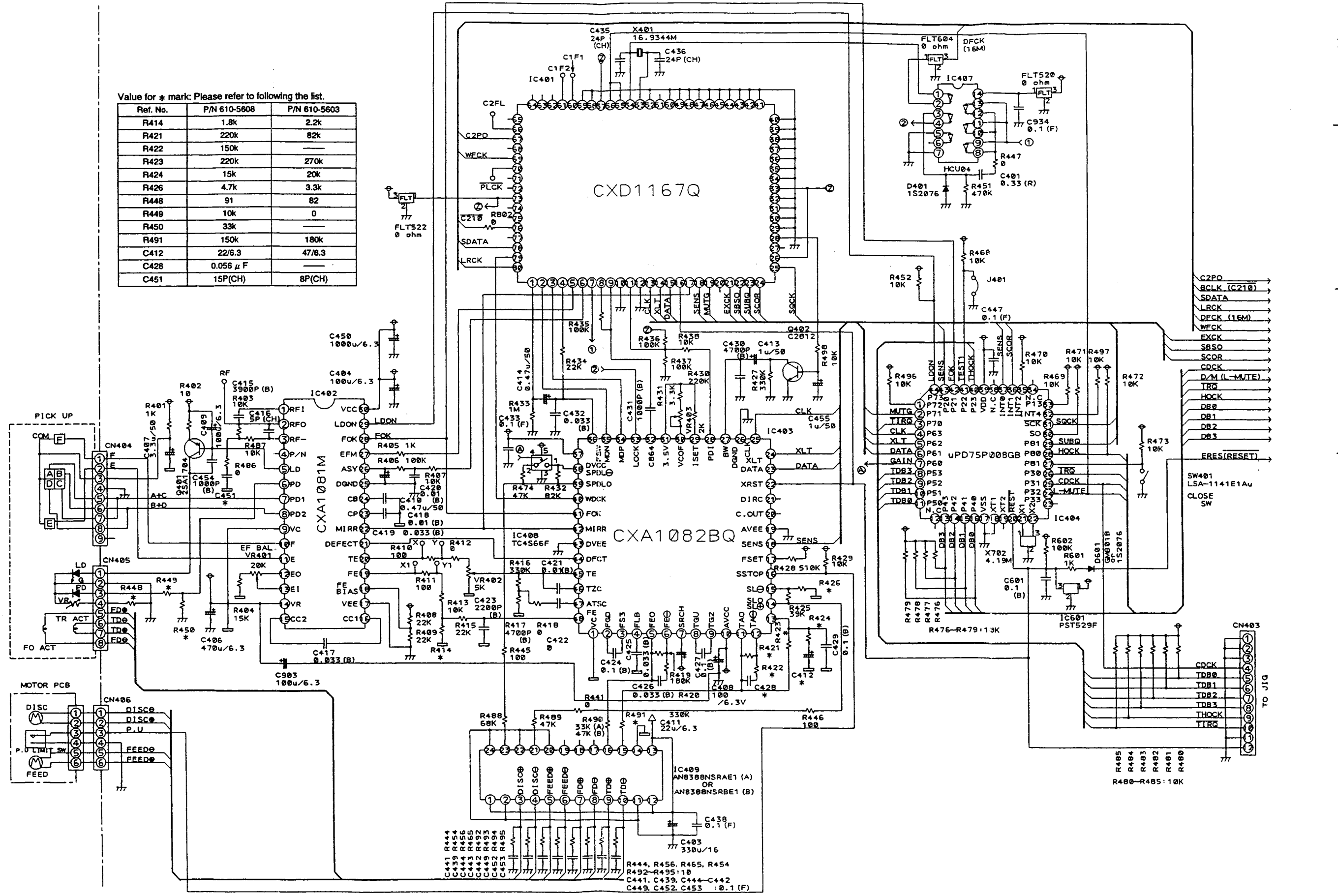

- C2PO
- BCLK (C210)
- SDATA
- LRCK
- DECK (16M)
- WFLK
- EXCK
- SBSO
- SCOR
- CDCK
- D/M (L-MUTE)
- TRG
- HOCK
- DB0
- DB1
- DB2
- DB3
- ERES(RESET)

- CDCK
- TDB0
- TDB1
- TDB2
- TDB3
- THOCK
- TRG

R485  
R484  
R483  
R482  
R481  
R480  
R480-R485: 10K

R444, R456, R465, R454  
R492-R495: 10  
C441, C439, C444-C442  
C449, C452, C453 : 0.1 (F)





# 4. EXPLODED VIEW & PARTS LIST

## 4-1. Exploded View

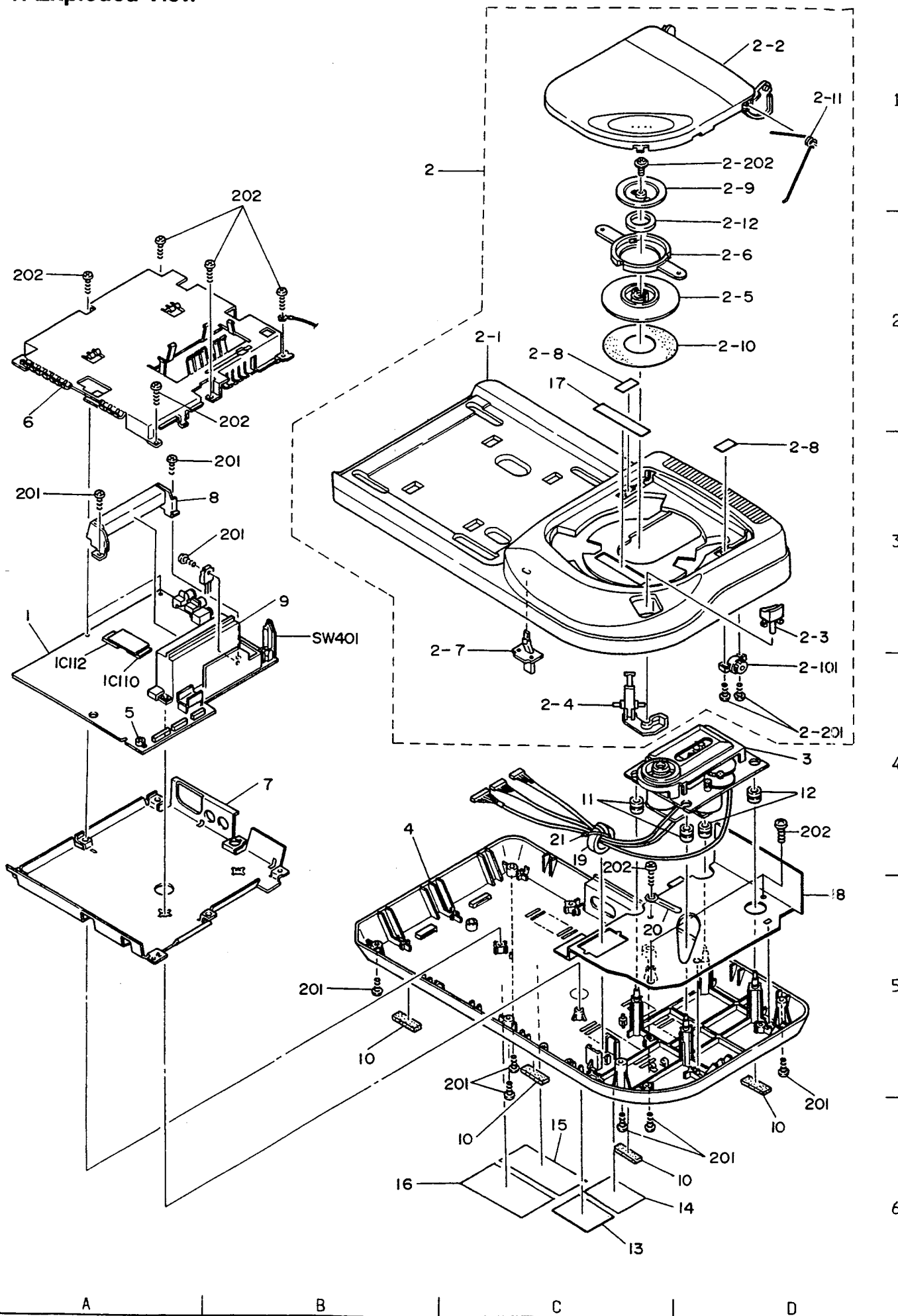

## 4-2. Mechanical Parts List

Ref. No.	Parts No.	Description
1	837-10210	IC BD SEGA-CD2 MAIN USA CH [KS]
1	837-10213	IC BD SEGA-CD2 MAIN USA CHSS [SS]
1	837-10211	IC BD MEGA-CD2 MAIN MULTI CH [KM]
1	837-10214	IC BD MEGA-CD2 MAIN MULTI CHSS [SM]
2	610-5466	ASSY TOP CASE SEGA-CD2 USA [KS, SS]
2	610-5467	ASSY TOP CASE MEGA-CD2 MULTI [KM, SM]
2-1	253-6661	TOP CASE MEGA-CD2 EXPORT
2-2	253-6635	DOOR SEGA-CD2 USA [KS, SS]
2-2	253-6636	DOOR MEGA-CD2 MULTI [KM, SM]
2-3	253-6562-01	DOOR KNOB SEGA-CD2 USA [KS, SS]
2-3	253-6562-02	DOOR KNOB MEGA-CD2 MULTI [KM, SM]
2-4	253-6563	DOOR LEVER MEGA-CD2
2-5	253-6564	CHUCK DISK MEGA-CD2
2-6	253-6565	CHUCK HOLDER MEGA-CD2
2-7	253-6566	LED LENS MEGA-CD2
2-8	253-6569	BLIND SHEET MEGA-CD2
2-9	250-5306	CONNECT PLATE MEGA-CD2
2-10	601-6983	CHUCK SHEET MEGA-CD2
2-11	125-5101	DOOR SPRING MEGA-CD2
2-12	113-0020	MAGNET MEGA-CD2 TK-4094 TOKIN
2-101	601-7018	OIL DAMPER MEGA-CD2
2-201	012-P00210	TAP SCR PH 2X10
2-202	029-000016	CUP SCR 2.6*5
3	610-5608	CD DRIVE UNIT MEGA-CD2 V2 [KS, KM]
3	610-5603	CD DRIVE UNIT MEGA-CD2 SS [SS, SM]
4	253-6651	BOTTOM CASE MEGA-CD2 EXPORT [KS, SS]
4	253-6651A	BOTTOM CASE MCD2 EXPORT ALPEX [KM, SM]
5	253-6567	LED HOLDER MEGA-CD2
6	250-5327	TOP SHIELD CD2 EXPORT
7	250-5328	BOTTOM SHIELD CD2 EXPORT
8	250-5325	CONNECTER SHIELD A CD2 EXPORT
9	250-5326	CONNECTER SHIELD B CD2 EXPORT
10	601-6982	RUBBER FOOT MEGA-CD2
11	601-6984	RUBBER DAMPER A MEGA-CD2
12	601-7002	RUBBER DAMPER B MEGA-CD2
13	670-3119	LABEL SER. NO. MK-4101 USA [KS, SS]
13	670-3120	LABEL SER. NO. MEGA-CD2 MULTI [KM, SM]
14	670-3126-01	LABEL FDA MK-4101 USA [KS, SS]
14	670-2774	LABEL CAUTION LASER EUROPE [KM, SM]
15	670-0248	SEAL CUSTOMER SERVICE [KS, SS]
15	670-4562	LABEL RF I & CE MARK [KM, SM]
16	670-3204A	LABEL FCC & ALPEX SCD2 USA [KS, SS]
17	670-3210	CAUTION LABEL MEGA-CD2 MULTI [KM, SM]
17	670-3209	CAUTION LABEL SEGA-CD2 USA [KS, SS]
18	250-5350	CD UNIT SHIELD CD2 EXPORT
19	270-5074	FERRITE CORE CD2 EXPORT
20	280-5242	HARNES LUG L=35MM
21	601-0460	PLASTIC TIE BELT 100 M/M
201	012-P00310	TAP SCR PH 3X10
202	012-P00308	TAP SCR PH 3X8

## 4-3. Electrical Parts List

Circuit No.	Parts No.	Description
IC101	315-5632	IC CUSTOM CHIP MCE3 FUJITSU
IC102	315-0745-80	IC TC511664BJ-80 SOJ TOSHIBA
IC102	315-0804-70	IC UPD421664LE-70 SOJ NEC
IC102	315-0804-80	IC UPD421664-80 SOJ NEC
IC102	315-0805-80	IC UPD421664-80L SOJ NEC
IC103	315-0745-80	IC TC511664BJ-80 SOJ TOSHIBA
IC103	315-0804-70	IC UPD421664LE-70 SOJ NEC
IC103	315-0804-80	IC UPD421664-80 SOJ NEC
IC103	315-0805-80	IC UPD421664-80L SOJ NEC
IC104	315-0651	IC MB8464A-80 SOP 28P FUJITSU
IC104	315-0651-90	IC MB8464A-90 SOP 28P
IC104	315-0773	IC CXK5864CM-70LL-T6 SOP SONY
IC104	315-0796-70	IC CXK5864BM-70 SOP SONY
IC105	315-0651	IC MB8464A-80 SOP 28P FUJITSU
IC105	315-0651-90	IC MB8464A-90 SOP 28P
IC105	315-0773	IC CXK5864CM-70LL-T6 SOP SONY
IC105	315-0796-70	IC CXK5864BM-70 SOP SONY
IC106	313-5181-01	IC LC89515 QFP SANYO
IC107	315-0739-80	IC UPD424270LE-80 NEC
IC107	315-0777-80	IC HM514270AJ-8 SOJ HITACHI
IC107	315-0818	IC MSM44270AJ-8 SOJ MITSUBISHI
IC107	315-0822-80	IC MN414270SJ-08 SOJ PANASONIC
IC108	315-0677	IC TC51832FL-10 SOP TOSHIBA
IC108	315-0759-10	IC TC51832AFL-10 SOP TOSHIBA
IC108	315-0760-10	IC LH5P832N-10 SOP SHARP
IC109	315-0677	IC TC51832FL-10 SOP TOSHIBA
IC109	315-0759-10	IC TC51832AFL-10 SOP TOSHIBA
IC109	315-0760-10	IC LH5P832N-10 SOP SHARP
IC110	315-5476A	IC CUSTOM CHIP RF5C164A RICO
IC111	MPR-15511	SEGA-CD2 USA BOOT ROM [KS, SS]
IC111	MPR-15511A	SEGA-CD2 USA BOOT ROM [KS, SS]
IC111	MPR-15512	IC MEGA-CD2 (PAL) BOOT ROM L661 [KM, SM]
IC111	MPR-15512A	IC MEGA-CD2 (PAL) BOOT ROM VER2 [KM, SM]
IC112	315-0635	IC MB8464A-10LL PF-G-BND FUJIT
IC113	315-0637	IC MC68HC000FN12 PLCC MOTOROLA
IC113	315-0650	IC HD68HC000CP-12 PLCC HITACHI
IC114	313-5190	IC MB3790 SOP 16PIN FUJITSU
IC115	NOT USED	
IC116	314-0549-01	IC TC74HC86 SOP TOSHIBA
IC201	313-5184	IC LC7883KM SOP SANYO
IC202	313-5231	IC LC78815M SOP 20P SANYO
IC203	313-5249	IC NUM3403AM SOP
IC204	313-5249	IC NUM3403AM SOP
IC205	313-5250	IC NUM3404AM SOP
IC301	313-5193	IC UPC2405HF NEC
IC401	315-0798	IC CXD1167Q QFP
IC402	313-5251	IC CXA1081M SOP
IC403	313-5252	IC CXA1082Q QFP
IC404	315-0799	IC UPD75P008GB QFP
IC404	315-0808	IC UPD75006GB QFP
IC404	315-0848	IC UPD75006GB-639-3B4
IC407	314-0571	IC 74HC04 SOP
IC408	313-5253	IC TC4566F-TE85R
IC409	314-0572	IC AN8388SR SOP
IC409	314-0585	IC AN8388SRBE1 SOP
IC601	314-0573	IC PST529F MMP3P RESET IC
IC951	315-0853	IC TC7S04F
IC952	314-0407	IC 74HC74

[NOTE] [KS]: SEGA CD II, CD DRIVE UNIT P/N 610-5608  
[KM]: MEGA CD II, CD DRIVE UNIT P/N 610-5608

[SS]: SEGA CD II, CD DRIVE UNIT P/N 610-5603  
[SM]: MEGA CD II, CD DRIVE UNIT P/N 610-5603

Circuit No.	Parts No.	Description	Circuit No.	Parts No.	Description	Circuit No.	Parts No.	Description	Circuit No.	Parts No.	Description
Q 101	482-5191	XSTR CHIP 2SC2812-5-CP-TB	RA102	477-0152	RES PACK CP 8*4. 7K OHM W/COMM	R 226	476-2472-J-10	RES CHIP 4. 7KOHM 1/10W 5%	R 432	476-2823-J-10	RES CHIP 82K OHM 1/10W 5%
Q 101	482-5192	XSTR CHIP 2SC2812-6-CP-TB				R 229	476-2750-J-10	RES CHIP 75 OHM 1/10W 5%	R 433	476-2105-J-10	RES CHIP 1MOHM 1/10W 5%
Q 201	482-5191	XSTR CHIP 2SC2812-5-CP-TB	RB101	476-2221-J-10	RES CHIP 220 OHM 1/10W 5%	R 230	476-2472-J-10	RES CHIP 4. 7KOHM 1/10W 5%	R 434	476-2223-J-10	RES CHIP 22KOHM 1/10W 5%
Q 201	482-5192	XSTR CHIP 2SC2812-6-CP-TB	RB102	476-2221-J-10	RES CHIP 220 OHM 1/10W 5%				R 435	476-2104-J-10	RES CHIP 100KOHM 1/10W 5%
Q 202	482-5191	XSTR CHIP 2SC2812-5-CP-TB	RB103	476-2221-J-10	RES CHIP 220 OHM 1/10W 5%	R 231	476-2472-J-10	RES CHIP 4. 7KOHM 1/10W 5%	R 436	476-2104-J-10	RES CHIP 100KOHM 1/10W 5%
Q 202	482-5192	XSTR CHIP 2SC2812-6-CP-TB	RB104	476-2221-J-10	RES CHIP 220 OHM 1/10W 5%	R 232	476-2472-J-10	RES CHIP 4. 7KOHM 1/10W 5%			
Q 301	482-5193	XSTR 2SB963 M	RB105	476-2221-J-10	RES CHIP 220 OHM 1/10W 5%	R 233	476-2472-J-10	RES CHIP 4. 7KOHM 1/10W 5%	R 437	476-2104-J-10	RES CHIP 100KOHM 1/10W 5%
Q 301	482-5194	XSTR 2SB963 L	RB106	476-2221-J-10	RES CHIP 220 OHM 1/10W 5%	R 234	476-2472-J-10	RES CHIP 4. 7KOHM 1/10W 5%	R 438	476-2103-J-10	RES CHIP 10KOHM 1/10W 5%
Q 301	482-5195	XSTR 2SB963 K	RB107	476-2221-J-10	RES CHIP 220 OHM 1/10W 5%	R 235	476-2331-J-10	RES CHIP 330 OHM 1/10W 5%	R 441	479-5010-J-10	RES CHIP 0 OHM 1/10W
Q 302	482-5191	XSTR CHIP 2SC2812-5-CP-TB	RB108	476-2221-J-10	RES CHIP 220 OHM 1/10W 5%	R 236	476-2331-J-10	RES CHIP 330 OHM 1/10W 5%	R 444	476-2100-J-10	RES CHIP 10 OHM 1/10W 5%
Q 302	482-5192	XSTR CHIP 2SC2812-6-CP-TB	RB109	476-2221-J-10	RES CHIP 220 OHM 1/10W 5%	R 237	476-2332-J-10	RES CHIP 3. 3KOHM 1/10W 5%	R 445	476-2101-J-10	RES CHIP 100 OHM 1/10W 5%
Q 302	482-5204	XSTR CHIP 2SC4362	RB110	476-2221-J-10	RES CHIP 220 OHM 1/10W 5%	R 238	476-2332-J-10	RES CHIP 3. 3KOHM 1/10W 5%	R 446	476-2101-J-10	RES CHIP 100 OHM 1/10W 5%
Q 302	482-5205	XSTR CHIP UN221L	RB111	476-2221-J-10	RES CHIP 220 OHM 1/10W 5%	R 239	476-2332-J-10	RES CHIP 3. 3KOHM 1/10W 5%	R 447	479-5010-J-10	RES CHIP 0 OHM 1/10W
Q 401	482-5196	XSTR 2SA1704 S-AN	RB112	476-2221-J-10	RES CHIP 220 OHM 1/10W 5%	R 240	476-2332-J-10	RES CHIP 3. 3KOHM 1/10W 5%	R 448	476-2820-J-10	RES CHIP 82 OHM 1/10W 5%
Q 401	482-5197	XSTR 2SA1704 T-AN	RB113	476-2221-J-10	RES CHIP 220 OHM 1/10W 5%	R 241	476-2750-J-10	RES CHIP 75 OHM 1/10W 5%	R 448	476-2910-J-10	RES CHIP 91 OHM 1/10W 5%
Q 402	482-5191	XSTR CHIP 2SC2812-5-CP-TB	RB114	476-2221-J-10	RES CHIP 220 OHM 1/10W 5%	R 242	476-2750-J-10	RES CHIP 75 OHM 1/10W 5%			
Q 402	482-5192	XSTR CHIP 2SC2812-6-CP-TB	RB115	476-2221-J-10	RES CHIP 220 OHM 1/10W 5%	R 243	476-2152-J-10	RES CHIP 1. 5KOHM 1/10W 5%	R 449	476-2103-J-10	RES CHIP 10KOHM 1/10W 5%
D 301	481-5119	DIODE DSK10-ET1	RB116	476-2221-J-10	RES CHIP 220 OHM 1/10W 5%	R 244	476-2122-J-10	RES CHIP 1. 2KOHM 1/10W 5%	R 449	479-5010-J-10	RES CHIP 0 OHM 1/10W
D 302	481-5120	DIODE 1S2076RE	SW401	250-5342	SW COVER CD2 SY	R 301	476-2472-J-10	RES CHIP 4. 7KOHM 1/10W 5%	R 450	476-2333-J-10	RES CHIP 33KOHM 1/10W 5%
D 302	NOT USED	NOT USED	VR401	475-0073	V. RES C TRM 20K OHM B RADIAL	R 301	476-2822-J-10	RES CHIP 8. 2KOHM 1/10W 5%	R 450	NOT USED	NOT USED
D 401	481-5120	DIODE 1S2076RE	VR402	475-0074	V. RES C TRM 5K OHM B RADIAL	R 302	476-2162-J-10	RES CHIP 1. 6KOHM 1/10W 5%	R 451	476-2474-J-10	RES CHIP 470KOHM 1/10W 5%
D 601	481-5120	DIODE 1S2076RE	VR403	475-0075	V. RES C TRM 2K OHM B RADIAL	R 302	NOT USED	NOT USED	R 452	476-2103-J-10	RES CHIP 10KOHM 1/10W 5%
BT101	401-0037	BATTERY ML2016-HS1 SANYO	VR404	NOT USED	NOT USED	R 303	476-2162-J-10	RES CHIP 1. 6KOHM 1/10W 5%	R 454	476-2100-J-10	RES CHIP 10 OHM 1/10W 5%
CN101	209-5068	EDGE CONN 60PIN CD2 CUSTOM	X 101	230-5103	XTAL OSC 50.000MHZ JX0-7	R 304	476-2472-J-10	RES CHIP 4. 7KOHM 1/10W 5%	R 456	476-2100-J-10	RES CHIP 10 OHM 1/10W 5%
CN201	210-5114	STEREO MINIJACK HSJ2000-01-010	X 401	230-5104	XTAL OSC 16.9344MHZ HC-49U	R 401	476-2102-J-10	RES CHIP 1KOHM 1/10W 5%	R 468	476-2103-J-10	RES CHIP 10KOHM 1/10W 5%
CN202	210-5115	RCA JACK YKC21-0242	X 702	230-5109	CER OSC 4.19MHZ	R 402	476-2100-J-10	RES CHIP 10 OHM 1/10W 5%	R 469	476-2103-J-10	RES CHIP 10KOHM 1/10W 5%
CN301	212-5378	DC JACK HECO470-01-630	R 101	476-2361-J-10	RES CHIP 360 OHM 1/10W 5%	R 403	476-2103-J-10	RES CHIP 10KOHM 1/10W 5%	R 470	476-2103-J-10	RES CHIP 10KOHM 1/10W 5%
CN403	212-5382	PIN HEADER ST 1L-S-12P-S2T2-EF	R 102	476-2472-J-10	RES CHIP 4. 7KOHM 1/10W 5%	R 404	476-2153-J-10	RES CHIP 15KOHM 1/10W 5%	R 471	476-2103-J-10	RES CHIP 10KOHM 1/10W 5%
CN404	212-5379	CONN BASE 9P B9B-PH-K-S	R 103	476-2222-J-10	RES CHIP 2. 2KOHM 1/10W 5%	R 405	476-2102-J-10	RES CHIP 1KOHM 1/10W 5%	R 472	476-2103-J-10	RES CHIP 10KOHM 1/10W 5%
CN405	212-5380	CONN BASE 8P B8B-PH-K-S	R 104	476-2473-J-10	RES CHIP 47KOHM 1/10W 5%	R 406	476-2104-J-10	RES CHIP 100KOHM 1/10W 5%	R 473	476-2103-J-10	RES CHIP 10KOHM 1/10W 5%
CN406	212-5381	CONN BASE 6P B6B-PH-K-S	R 105	476-2472-J-10	RES CHIP 4. 7KOHM 1/10W 5%	R 407	476-2103-J-10	RES CHIP 10KOHM 1/10W 5%	R 474	476-2473-J-10	RES CHIP 47KOHM 1/10W 5%
EMI202	271-0007	EMI FILTER STX222MB	R 106	476-2472-J-10	RES CHIP 4. 7KOHM 1/10W 5%	R 408	476-2223-J-10	RES CHIP 22KOHM 1/10W 5%	R 476	476-2103-J-10	RES CHIP 10KOHM 1/10W 5%
EMI202	271-0073	EMI FILTER ED31-D222M	R 107	479-5010-J-10	RES CHIP 0 OHM 1/10W	R 409	476-2223-J-10	RES CHIP 22KOHM 1/10W 5%	R 477	476-2103-J-10	RES CHIP 10KOHM 1/10W 5%
EMI202	479-5009	RES 0 OHM 1/4W	R 108	479-5010-J-10	RES CHIP 0 OHM 1/10W	R 410	476-2101-J-10	RES CHIP 100 OHM 1/10W 5%	R 478	476-2103-J-10	RES CHIP 10KOHM 1/10W 5%
EMI203	271-0007	EMI FILTER STX222MB	R 109	479-5010-J-10	RES CHIP 0 OHM 1/10W	R 411	476-2101-J-10	RES CHIP 100 OHM 1/10W 5%	R 479	476-2103-J-10	RES CHIP 10KOHM 1/10W 5%
EMI203	271-0073	EMI FILTER ED31-D222M	R 110	NOT USED	NOT USED	R 412	479-5010-J-10	RES CHIP 0 OHM 1/10W	R 480	476-2103-J-10	RES CHIP 10KOHM 1/10W 5%
EMI203	479-5009	RES 0 OHM 1/4W	R 130	479-5010-J-10	RES CHIP 0 OHM 1/10W	R 413	476-2103-J-10	RES CHIP 10KOHM 1/10W 5%	R 481	476-2103-J-10	RES CHIP 10KOHM 1/10W 5%
EMI204	479-5009	RES 0 OHM 1/4W	R 131	479-5010-J-10	RES CHIP 0 OHM 1/10W	R 414	476-2182-J-10	RES CHIP 1. 8KOHM 1/10W 5%	R 482	476-2103-J-10	RES CHIP 10KOHM 1/10W 5%
EMI205	479-5009	RES 0 OHM 1/4W	R 201	476-2162-J-10	RES CHIP 1. 6KOHM 1/10W 5%	R 414	476-2222-J-10	RES CHIP 2. 2KOHM 1/10W 5%	R 483	476-2103-J-10	RES CHIP 10KOHM 1/10W 5%
EMI206	479-5009	RES 0 OHM 1/4W	R 202	476-2102-J-10	RES CHIP 1KOHM 1/10W 5%	R 415	476-2223-J-10	RES CHIP 22KOHM 1/10W 5%	R 484	476-2103-J-10	RES CHIP 10KOHM 1/10W 5%
F 301	514-5060	FUSE PICO II 25102.5 AXIAL	R 203	476-2472-J-10	RES CHIP 4. 7KOHM 1/10W 5%	R 416	476-2334-J-10	RES CHIP 330K OHM 1/10W 5%	R 485	476-2103-J-10	RES CHIP 10KOHM 1/10W 5%
FL301	271-0054	LINE FILTER CMO8RB01	R 204	476-2472-J-10	RES CHIP 4. 7KOHM 1/10W 5%	R 417	151-0421	CAP CER CH 4700PF/50V B K	R 486	479-5010-J-10	RES CHIP 0 OHM 1/10W
FLT505	271-0058	FILMAC TH30333MAT	R 205	476-2472-J-10	RES CHIP 4. 7KOHM 1/10W 5%	R 418	479-5010-J-10	RES CHIP 0 OHM 1/10W	R 487	476-2103-J-10	RES CHIP 10KOHM 1/10W 5%
FLT506	479-5009	RES 0 OHM 1/4W	R 206	476-2472-J-10	RES CHIP 4. 7KOHM 1/10W 5%	R 419	476-2184-J-10	RES CHIP 180KOHM 1/10W 5%	R 488	476-2683-J-10	RES CHIP 68KOHM 1/10W 5%
FLT507	479-5009	RES 0 OHM 1/4W	R 207	476-2472-J-10	RES CHIP 4. 7KOHM 1/10W 5%	R 420	476-2334-J-10	RES CHIP 330K OHM 1/10W 5%	R 489	476-2473-J-10	RES CHIP 47KOHM 1/10W 5%
FLT512	271-0058	FILMAC TH30333MAT	R 208	476-2222-J-10	RES CHIP 2. 2KOHM 1/10W 5%	R 421	476-2224-J-10	RES CHIP 220KOHM 1/10W 5%	R 490	476-2333-J-10	RES CHIP 33KOHM 1/10W 5%
FLT516	479-5009	RES 0 OHM 1/4W	R 209	476-2222-J-10	RES CHIP 2. 2KOHM 1/10W 5%	R 421	476-2823-J-10	RES CHIP 82KOHM 1/10W 5%	R 490	476-2473-J-10	RES CHIP 47KOHM 1/10W 5%
FLT519	479-5009	RES 0 OHM 1/4W	R 210	476-2472-J-10	RES CHIP 4. 7KOHM 1/10W 5%	R 422	476-2154-J-10	RES CHIP 150K OHM 1/10W 5%	R 491	476-2154-J-10	RES CHIP 150KOHM 1/10W 5%
FLT520	479-5009	RES 0 OHM 1/4W	R 211	476-2222-J-10	RES CHIP 2. 2KOHM 1/10W 5%	R 422	NOT USED	NOT USED	R 491	476-2184-J-10	RES CHIP 180KOHM 1/10W 5%
FLT522	479-5009	RES 0 OHM 1/4W	R 212	476-2222-J-10	RES CHIP 2. 2KOHM 1/10W 5%	R 423	476-2224-J-10	RES CHIP 220KOHM 1/10W 5%	R 492	476-2100-J-10	RES CHIP 10 OHM 1/10W 5%
FLT600	479-5009	RES 0 OHM 1/4W	R 213	476-2472-J-10	RES CHIP 4. 7KOHM 1/10W 5%	R 423	476-2274-J-10	RES CHIP 270KOHM 1/10W 5%	R 493	476-2100-J-10	RES CHIP 10 OHM 1/10W 5%
FLT601	271-0059	FILMAC TX09500NB	R 214	476-2472-J-10	RES CHIP 4. 7KOHM 1/10W 5%	R 424	476-2153-J-10	RES CHIP 15KOHM 1/10W 5%	R 494	476-2100-J-10	RES CHIP 10 OHM 1/10W 5%
FLT602	271-0060	FILMAC TX07250NB	R 215	476-2331-J-10	RES CHIP 330 OHM 1/10W 5%	R 424	476-2203-J-10	RES CHIP 20KOHM 1/10W 5%	R 495	476-2100-J-10	RES CHIP 10 OHM 1/10W 5%
FLT604	479-5009	RES 0 OHM 1/4W	R 216	476-2100-J-10	RES CHIP 10 OHM 1/10W 5%	R 425	476-2393-J-10	RES CHIP 39KOHM 1/10W 5%	R 496	476-2103-J-10	RES CHIP 10KOHM 1/10W 5%
LD101	390-5449	LED LN88RPX	R 217	476-2331-J-10	RES CHIP 330 OHM 1/10W 5%	R 425	476-2332-J-10	RES CHIP 3. 3KOHM 1/10W 5%	R 497	476-2103-J-10	RES CHIP 10KOHM 1/10W 5%
RA101	477-0152	RES PACK CP 8*4. 7K OHM W/COMM	R 218	476-2100-J-10	RES CHIP 10 OHM 1/10W 5%	R 425	476-2472-J-10	RES CHIP 4. 7KOHM 1/10W 5%	R 498	476-2103-J-10	RES CHIP 10KOHM 1/10W 5%
			R 219	476-2472-J-10	RES CHIP 4. 7KOHM 1/10W 5%	R 426	476-2332-J-10	RES CHIP 3. 3KOHM 1/10W 5%	R 502	476-2104-J-10	RES CHIP 100KOHM 1/10W 5%
			R 220	476-2472-J-10	RES CHIP 4. 7KOHM 1/10W 5%	R 426	476-2472-J-10	RES CHIP 4. 7KOHM 1/10W 5%	R 701	479-5010-J-10	RES CHIP 0 OHM 1/10W
			R 221	476-2472-J-10	RES CHIP 4. 7KOHM 1/10W 5%	R 427	476-2334-J-10	RES CHIP 330K OHM 1/10W 5%	R 702	476-2330-J-10	RES CHIP 33 OHM 1/10W 5%
			R 222	476-2472-J-10	RES CHIP 4. 7KOHM 1/10W 5%	R 427	476-2514-J-10	RES CHIP 510KOHM 1/10W 5%	R 703	476-2330-J-10	RES CHIP 33 OHM 1/10W 5%
			R 223	476-2222-J-10	RES CHIP 2. 2KOHM 1/10W 5%	R 428	476-2103-J-10	RES CHIP 10KOHM 1/10W 5%	R 704	476-2330-J-10	RES CHIP 33 OHM 1/10W 5%
			R 224	476-2331-J-10	RES CHIP 330 OHM 1/10W 5%	R 431	476-2224-J-10	RES CHIP 220KOHM 1/10W 5%	R 705	476-2330-J-10	RES CHIP 33 OHM 1/10W 5%
			R 225	476-2222-J-10	RES CHIP 2. 2KOHM 1/10W 5%				R 706	476-2330-J-10	RES CHIP 33 OHM 1/10W 5%

[NOTE] [KS]: SEGA CD II, CD DRIVE UNIT P/N 610-5608  
[KM]: MEGA CD II, CD DRIVE UNIT P/N 610-5608

[SS]: SEGA CD II, CD DRIVE UNIT P/N 610-5603  
[SM]: MEGA CD II, CD DRIVE UNIT P/N 610-5603

[NOTE] [KS]: SEGA CD II, CD DRIVE UNIT P/N 610-5608  
[KM]: MEGA CD II, CD DRIVE UNIT P/N 610-5608

</

Circuit No.	Parts No.	Description	Circuit No.	Parts No.	Description
R 707	476-2330-J-10	RES CHIP 33 OHM 1/10W 5%	C 216	151-0405	CAP CER CP 0.1UF/16V F Z
R 708	476-2330-J-10	RES CHIP 33 OHM 1/10W 5%	C 217	151-0412	CAP CER CP 1200PF/50V B K
R 709	476-2330-J-10	RES CHIP 33 OHM 1/10W 5%	C 218	151-0412	CAP CER CP 1200PF/50V B K
R 710	476-2330-J-10	RES CHIP 33 OHM 1/10W 5%	C 219	151-0405	CAP CER CP 0.1UF/16V F Z
R 711	476-2330-J-10	RES CHIP 33 OHM 1/10W 5%	C 220	150-0439	CAP E 10UF/16V 20%
R 712	476-2330-J-10	RES CHIP 33 OHM 1/10W 5%	C 221	150-0439	CAP E 10UF/16V 20%
R 713	476-2330-J-10	RES CHIP 33 OHM 1/10W 5%	C 222	150-0439	CAP E 10UF/16V 20%
R 714	476-2330-J-10	RES CHIP 33 OHM 1/10W 5%	C 223	151-0413	CAP CER CP 2200PF/50V B K
R 715	476-2330-J-10	RES CHIP 33 OHM 1/10W 5%	C 224	151-0405	CAP CER CP 0.1UF/16V F Z
R 716	476-2330-J-10	RES CHIP 33 OHM 1/10W 5%	C 225	151-0411	CAP CER CP 8200PF/50V B K
R 717	476-2330-J-10	RES CHIP 33 OHM 1/10W 5%	C 226	151-0413	CAP CER CP 2200PF/50V B K
R 718	479-5010-J-10	RES CHIP 0 OHM 1/10W	C 227	151-0411	CAP CER CP 8200PF/50V B K
R 801	NOT USED	NOT USED	C 228	150-0439	CAP E 10UF/16V 20%
R 802	479-5010-J-10	RES CHIP 0 OHM 1/10W	C 229	150-0439	CAP E 10UF/16V 20%
C 101	NOT USED	NOT USED	C 230	151-0411	CAP CER CP 8200PF/50V B K
C 103	NOT USED	NOT USED	C 231	151-0411	CAP CER CP 8200PF/50V B K
C 104	150-0439	CAP E 10UF/16V 20%	C 232	150-0439	CAP E 10UF/16V 20%
C 105	151-0405	CAP CER CP 0.1UF/16V F Z	C 233	150-0439	CAP E 10UF/16V 20%
C 109	151-0405	CAP CER CP 0.1UF/16V F Z	C 234	150-0439	CAP E 10UF/16V 20%
C 110	150-0439	CAP E 10UF/16V 20%	C 235	150-0439	CAP E 10UF/16V 20%
C 111	NOT USED	NOT USED	C 236	150-0439	CAP E 10UF/16V 20%
C 112	NOT USED	NOT USED	C 237	150-0439	CAP E 10UF/16V 20%
C 113	151-0406	CAP CER CP 100PF/50V SL J	C 238	150-0440	CAP E 100UF/6.3V 20%
C 114	151-0405	CAP CER CP 0.1UF/16V F Z	C 239	150-0439	CAP E 10UF/16V 20%
C 115	150-0439	CAP E 10UF/16V 20%	C 240	150-0439	CAP E 10UF/16V 20%
C 116	NOT USED	NOT USED	C 301	150-0440	CAP E 100UF/6.3V 20%
C 117	NOT USED	NOT USED	C 302	151-0405	CAP CER CP 0.1UF/16V F Z
C 118	151-0406	CAP CER CP 100PF/50V SL J	C 303	150-0441	CAP E 1000UF/6.3V 20%
C 119	151-0405	CAP CER CP 0.1UF/16V F Z	C 304	151-0405	CAP CER CP 0.1UF/16V F Z
C 120	151-0405	CAP CER CP 0.1UF/16V F Z	C 305	150-0249	CAP E 330UF 16V U-TYPE
C 122	150-0439	CAP E 10UF/16V 20%	C 306	150-0440	CAP E 100UF/6.3V 20%
C 123	NOT USED	NOT USED	C 401	151-0456	CAP CER CP 0.33UF/16V R K
C 124	NOT USED	NOT USED	C 403	150-0249	CAP E 330UF/16V U-TYPE
C 125	NOT USED	NOT USED	C 404	150-0440	CAP E 100UF/6.3V 20%
C 126	151-0405	CAP CER CP 0.1UF/16V F Z	C 405	NOT USED	NOT USED
C 127	150-0439	CAP E 10UF/16V 20%	C 406	150-0301	CAP E 470UF/6.3V U-TYPE
C 128	151-0405	CAP CER CP 0.1UF/16V F Z	C 407	150-0329	CAP E 3.3UF/50V U-TYPE
C 129	150-0439	CAP E 10UF/16V 20%	C 408	150-0440	CAP E 100UF/6.3V 20%
C 130	151-0405	CAP CER CP 0.1UF/16V F Z	C 409	150-0440	CAP E 100UF/6.3V 20%
C 131	150-0439	CAP E 10UF/16V 20%	C 410	150-0442	CAP E 0.47UF/50V 20%
C 132	150-0439	CAP E 10UF/16V 20%	C 411	150-0443	CAP E 22UF/6.3V 20%
C 133	151-0405	CAP CER CP 0.1UF/16V F Z	C 412	150-0443	CAP E 22UF/6.3V 20%
C 135	151-0405	CAP CER CP 0.1UF/16V F Z	C 412	150-0467	CAP E 47UF/6.3V 20%
C 136	NOT USED	NOT USED	C 413	150-0016	CAP E 1UF/50V
C 137	151-0405	CAP CER CP 0.1UF/16V F Z	C 414	150-0442	CAP E 0.47UF/50V 20%
C 138	151-0405	CAP CER CP 0.1UF/16V F Z	C 415	151-0415	CAP CER CP 3900PF/50V B K
C 139	150-0439	CAP E 10UF/16V 20%	C 416	151-0416	CAP CER CP 5PF/50V CH C
C 141	NOT USED	NOT USED	C 417	151-0506	CAP CER CP 0.033UF/25V B K
C 143	151-0409	CAP CER CP 1000PF/50V B K	C 418	151-0418	CAP CER CP 0.01UF/50V B K
C 144	151-0405	CAP CER CP 0.1UF/16V F Z	C 418	151-0509	CAP CER CP 0.01UF/25V B K
C 145	NOT USED	NOT USED	C 419	151-0506	CAP CER CP 0.033UF/25V B K
C 146	NOT USED	NOT USED	C 420	151-0418	CAP CER CP 0.01UF/50V B K
C 201	150-0440	CAP E 100UF/6.3V 20%	C 420	151-0509	CAP CER CP 0.01UF/25V B K
C 202	NOT USED	NOT USED	C 421	151-0418	CAP CER CP 0.01UF/50V B K
C 203	NOT USED	NOT USED	C 421	151-0509	CAP CER CP 0.01UF/25V B K
C 204	NOT USED	NOT USED	C 422	479-5010-J-10	RES CHIP 0OHM 1/10W
C 206	150-0439	CAP E 10UF/16V 20%	C 423	151-0413	CAP CER CP 2200PF/50V B K
C 207	150-0439	CAP E 10UF/16V 20%	C 424	151-0507	CAP CER CP 0.1UF/25V B K
C 208	150-0439	CAP E 10UF/16V 20%	C 425	151-0506	CAP CER CP 0.033UF/25V B K
C 209	150-0439	CAP E 10UF/16V 20%	C 426	151-0506	CAP CER CP 0.033UF/25V B K
C 210	150-0439	CAP E 10UF/16V 20%	C 427	151-0507	CAP CER CP 0.1UF/25V B K
C 211	151-0410	CAP CER CP 680PF/50V B K	C 428	151-0508	CAP CER CP 0.056UF/16V B K
C 212	151-0410	CAP CER CP 680PF/50V B K	C 428	NOT USED	NOT USED
C 213	151-0405	CAP CER CP 0.1UF/16V F Z			
C 214	151-0411	CAP CER CP 8200PF/50V B K			
C 215	151-0411	CAP CER CP 8200PF/50V B K			

[KS, KM]  
[SS, SM]

[KS, KM]  
[SS, SM]

[NOTE] [KS]: SEGA CD II, CD DRIVE UNIT P/N 610-5608  
[KM]: MEGA CD II, CD DRIVE UNIT P/N 610-5608

[SS]: SEGA CD II, CD DRIVE UNIT P/N 610-5603  
[SM]: MEGA CD II, CD DRIVE UNIT P/N 610-5603



## 4-4. Accessories/Package List

Circuit No.	Parts No.	Description	No.	Parts No.	Description
C 429	151-0507	CAP CER CP 0.1UF/25V B K	1	610-5507	ASSY CD ROM MDP ROAD AVENGER [KM, SM]
C 430	151-0421	CAP CER CH 4700PF/50V B K			
C 431	151-0409	CAP CER CP 1000PF/50V B K	2	400-5100B	AC ADAPTOR AC120V/DC10V 1.2A [KS, SS]
C 432	151-0506	CAP CER CP 0.033UF/25V B K	2	400-5100B-01	AC ADAPTOR AC120V/DC10V 1.2A [KS, SS]
C 433	151-0405	CAP CER CP 0.1UF/16V F Z	2	400-5122C	AC ADAPTOR AC230V/DC10V 1.2A [KM, SM]
C 435	151-0422	CAP CER CP 24PF/50V CH J	3	600-6201	STEREO MIXING CABLE W/CORE
C 436	151-0422	CAP CER CP 24PF/50V CH J	4	600-6204	AUDIO RCA CABLE L=2M UNION [KM, SM]
C 438	151-0405	CAP CER CP 0.1UF/16V F Z	5	610-5491	ASSY SPACER MEGA-CD2 EXPORT
C 439	151-0405	CAP CER CP 0.1UF/16V F Z	6	250-5346	HOLD PLATE SPACER MEGA-CD2 A
C 441	151-0405	CAP CER CP 0.1UF/16V F Z	7	250-5333	RETAINER BRACKET CD2 EXPORT
C 442	151-0405	CAP CER CP 0.1UF/16V F Z	8	250-5329	CONN PLATE A ACCESSORY CD2 EXP
C 443	151-0405	CAP CER CP 0.1UF/16V F Z	9	250-5330	CONN PLATE B ACCESSORY CD2 EXP
C 444	151-0405	CAP CER CP 0.1UF/16V F Z	10	000-F00410	M SCR FH M4X10
C 447	151-0405	CAP CER CP 0.1UF/16V F Z	11	671-3240-01	MA CTN SEGA-CD2 USA [KS, SS]
C 449	151-0405	CAP CER CP 0.1UF/16V F Z	11	671-3240-01E	MA CTN SEGA-CD2 USA E [KS, SS]
C 450	150-0441	CAP E 1000UF/6.3V 20%	11	671-3240-03	MA CTN MEGA-CD2 MULTI 4180 [KM, SM]
C 451	151-0436	CAP CER CP 15PF/50V CH J [KS, KM]	11	671-3240-06	MA CTN MEGA-CD2 MULTI 4182 [KM, SM]
C 451	151-0501	CAP CER CP 8PF/50V CH J [SS, SM]	12	672-1257	OPERATION MANUAL CD2 USA [KS, SS]
C 452	151-0405	CAP CER CP 0.1UF/16V F Z	12	672-1258	OPERATION MANUAL CD2 MULTI [KM, SM]
C 453	151-0405	CAP CER CP 0.1UF/16V F Z	12	672-1258-01	OPERATION MANUAL CD2 MULTI 01 [KM, SM]
C 454	151-0409	CAP CER CP 1000PF/50V B K	12	672-1258-02	OPERATION MANUAL CD2 MULTI 02 [KM, SM]
C 455	150-0016	CAP E 1UF/50V	12	672-1258-02A	OPERATION MANUAL CD2 MULTI 02A [KM, SM]
C 601	151-0507	CAP CER CP 0.1UF/25V B K	13	671-3322-01	BOX & PACK SET CD2 USA [KS, SS]
C 701	NOT USED	NOT USED	13	671-3980-01	BOX & PACK SET CD2 USA DP [KS, SS]
C 702	151-0437	CAP CER CP 150PF/50V CH J	13	671-3322-03	BOX & PACK SET CD2 MULTI 4180 [KM, SM]
C 703	151-0437	CAP CER CP 150PF/50V CH J	13	671-3322-06	BOX & PACK SET CD2 MULTI 4182 [KM, SM]
C 704	151-0437	CAP CER CP 150PF/50V CH J	13	671-3980-03	BOX & PACK SET CD2 MUL 4180 DP [KM, SM]
C 705	151-0437	CAP CER CP 150PF/50V CH J	13	671-3980-05	BOX & PACK SET CD2 MUL 4182 DP [KM, SM]
C 706	151-0437	CAP CER CP 150PF/50V CH J	14	670-3211	BUSINESS REPLY MAIL CD2 USA [KS, SS]
C 707	151-0437	CAP CER CP 150PF/50V CH J	14	670-2779	EPILEPSY WARNING SHEET MULTI [KM, SM]
C 708	151-0437	CAP CER CP 150PF/50V CH J	14	670-3551	EPILEPSY WARNING SHEET MUL V2 [KM, SM]
C 709	151-0437	CAP CER CP 150PF/50V CH J	15	670-3311	GUARANTEE CARD CD2 MULTI [KM, SM]
C 710	151-0437	CAP CER CP 150PF/50V CH J	15	670-3311-01	GUARANTEE CARD CD2 MULTI 01 [KM, SM]
C 711	151-0437	CAP CER CP 150PF/50V CH J	16	SGM-4218	POLY BAG 300*550*0.05 EXP 6
C 712	151-0437	CAP CER CP 150PF/50V CH J	17	SGM-4245	POLY BAG 200*310*0.05 EXP 6
C 713	151-0437	CAP CER CP 150PF/50V CH J	19	SGM-4207	POLY BAG 70*100*0.05
C 714	151-0437	CAP CER CP 150PF/50V CH J	20	SGM-4220	POLY BAG 120*300*0.02
C 715	151-0437	CAP CER CP 150PF/50V CH J	21	SGM-4259	POLY BAG 80*180*0.05
C 716	151-0437	CAP CER CP 150PF/50V CH J	22	670-3265	CROSS SELL POSTER GEN2 USA [KS, SS]
C 717	151-0437	CAP CER CP 150PF/50V CH J			
C 810	NOT USED	NOT USED			
C 901	NOT USED	NOT USED			
C 902	NOT USED	NOT USED			
C 903	150-0440	CAP E 100UF/6.3V 20%			
C 920	151-0438	CAP CER CP 0.022UF/25V B K			
C 921	151-0405	CAP CER CP 0.1UF/16V F Z			
C 922	151-0439	CAP CER CP 47PF/50V CH J			
C 923	151-0439	CAP CER CP 47PF/50V CH J			
C 930	151-0405	CAP CER CP 0.1UF/16V F Z			
C 931	151-0405	CAP CER CP 0.1UF/16V F Z			
C 932	NOT USED	NOT USED			
C 933	151-0405	CAP CER CP 0.1UF/16V F Z			
C 934	151-0405	CAP CER CP 0.1UF/16V F Z			
C 951	151-0405	CAP CER CP 0.1UF/16V F Z			
C 952	151-0405	CAP CER CP 0.1UF/16V F Z			

[NOTE] [KS]: SEGA CDII, CD DRIVE UNIT P/N 610-5608  
 [KM]: MEGA CDII, CD DRIVE UNIT P/N 610-5608

[SS]: SEGA CDII, CD DRIVE UNIT P/N 610-5603  
 [SM]: MEGA CDII, CD DRIVE UNIT P/N 610-5603

**SEGA™**

# Differences between MEGA-CD2/SEGA-CD2 (FUNAI) and MEGA-CD2/SEGA-CD2 (SONY)

Note: For components marked (※), components equivalent to those listed and made by other companies can also be used.

## ● Electrical Components

Component	MCD2/SCD2 (FUNAI)	NCD2/SCD2 (SONY)	Remarks
MAIN CPU	MC68HC00FN12 (※)	Same as on left (※)	
GAME PROCESSOR	CUSTOM CHIP MCE3	Same as on left	
PCM SOUND SOURCE	CUSTOM CHIP RF5C164A	Same as on left	
BOOT ROM (OS)	1M bit	Same as on left	The SONY ROM can be used in SONY and FUNAI units, but FUNAI ROM is exclusively for FUNAI units.
MEMORY FOR MAIN CPU'S PROGRAM	UPD424270LE-80 (※)	Same as on left (※)	
VOLTAGE DETECTOR	MB3790	Same as on left	
MEMORY FOR PROGRAM IN MEGA DRIVE/GENESIS AND CD GRAPHIC PROCESSING	TC511664BJ-80 SOJ (※)	Same as on left (※)	
MEMORY FOR CD ROM DECODER	CXK5864CM-70 (※)	Same as on left (※)	
MEMORY FOR PCM SOUND SOURCE	LH5P832-N-10 (※)	Same as on left (※)	
BACKUP MEMORY	MB8464A-10LL	Same as on left	
CD ROM DECODER	LC89515	Same as on left	
D/A (DIGITAL-TO-ANALOG) CONVERTER	LC7883KM	Same as on left	
	LC78815M	Same as on left	
OP AMP	NJM3403	Same as on left	
	NJM3404	Same as on left	
REGULATOR IC	UPC2405HF	Same as on left	
OSCILLATOR FOR CD DRIVE UNIT OPERATION	XTAL OSC 16.9344MHZ-HC49U	Same as on left	
	CER OSC 4.19MHZ	Built into CD drive unit.	
OSCILLATOR FOR DIGITAL UNIT OPERATION	XTAL OSC 50MHz JXO-7	Same as on left	
DIGITAL SIGNAL IC	CXD1167Q	CXD2500BQ	
MECHANISM CONTROL $\mu$ P	UPD75006	CXP5084-580Q	
SERVO SIGNAL IC	CXA1082	Built into CD drive unit.	
SERVO DRIVE IC	AN8388	Built into CD drive unit.	
RESET IC FOR CD DRIVE UNIT	PST529E MM3P	Same as on left	
RF AMP	CXA1081	Built into CD drive unit.	
PCM BOARD	Yes	Built into MAIN board	

MK

## ● Configuration of Circuit Boards

MEGA CD2/SEGA CD2 (SONY)

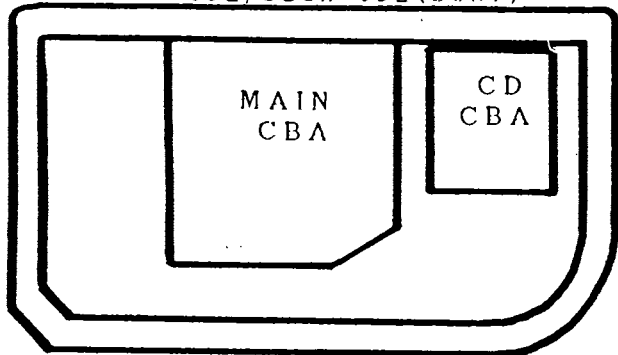

MEGA CD2/SEGA CD2 (FUNAI)

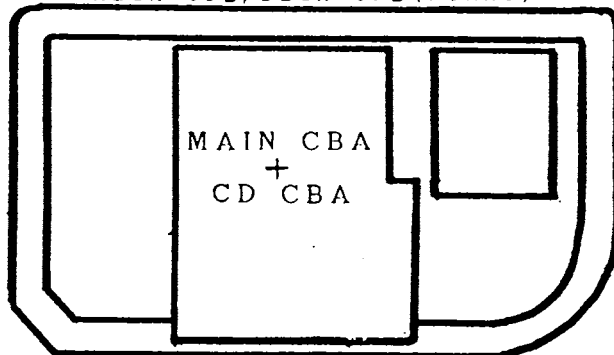

MODEL MK4102A  
HAA-2972A

MK4102

## Differences between MEGA-CD/SEGA-CD and MEGA-CD2/SEGA-CD2 (FUNAI) (1/2)

### ● Electrical Components

Note: For components marked (※), components equivalent to those listed and made by other companies can also be used.

Component	MCD/SCD	MCD2/SCD2 (FUNAI)	Remarks
MAIN CPU	MC68HC000FN12 (※)	Same as on left (※)	
GAME PROCESSOR	CUSTOM CHIP MCE2	CUSTOM CHIP MCE3	MCE3 is used in 50,000 MEGA-CD units
PCM SOUND SOURCE	CUSTOM CHIP RF5C164A	Same as on left	
BOOT ROM (OS)	1M bit	Same as on left	Only the program details are different.
MEMORY FOR MAIN CPU'S PROGRAM	UPD424270LE-10 (※)	Same as on left (※)	
VOLTAGE DETECTOR	MB3790	Same as on left	
MEMORY FOR PROGRAM IN MEGA DRIVE/GENESIS AND CD GRAPHIC PROCESSING	TC511664BZ-80 ZIP (※)	TC511664BJ-80 SOJ (※)	Package changed.
MEMORY FOR CD ROM DECODER	TC51832FL-10 (※)	CXK5864BM-70 (※)	
MEMORY FOR PCM SOUND SOURCE		LH5P832N-10 (※)	
BACKUP MEMORY	MB8464A-10LL	Same as on left	
CD ROM DECODER	LC8951	LC89515	
D/A (DIGITAL-TO-ANALOG) CONVERTER	LC7883KM LC7881M-C	Same as on left LC78815M	
OP AMP	UPC844G2 (3 ICs)	NJM3403AM (2 ICs) NJM3404AM (1 IC)	
REGULATOR IC	UPC2405HF	Same as on left	
OSCILLATOR FOR CD DRIVE UNIT OPERATION	Built into CD drive unit.	XTAL OSC 16.9344 MHZ HC-49U CER OSC 4.19 MHz	
OSCILLATOR FOR DIGITAL UNIT OPERATION	XTAL OSC 50MHz	XTAL OSC 50MHz JXO-7	
DIGITAL SIGNAL IC	Built into CD drive unit.	CXD1167Q	
MECHANISM CONTROL $\mu$ P		UPD75006	
SERVO SIGNAL IC	Built into CD drive unit.	CXA1082	
RF AMP		CXA1081	
SERVO DRIVE IC		AN8388	
RESET IC FOR CD DRIVE UNIT		PST529F MMP3P	
PCM BOARD	No	Yes	

# Differences between MEGA-CD/SEGA-CD and MEGA-CD2/SEGA-CD2 (FUNAI) (2/2)

## ● Features

Item	MCD/SCD	MCD2/SCD2 (FUNAI)	Remarks
CD LOADING	Front loading	Top loading	
DC JACK	Yes	Yes	
MIXING JACK	Yes	Yes	
LINE OUT	Yes	Yes	
READY INDICATOR	Yes	No	
ACCESS INDICATOR	Yes	Yes	
AC ADAPTER	1.2 A	1.2 A	Completely the same.

## ● Configuration of Circuit Boards

MEGA CD/SEGA CD

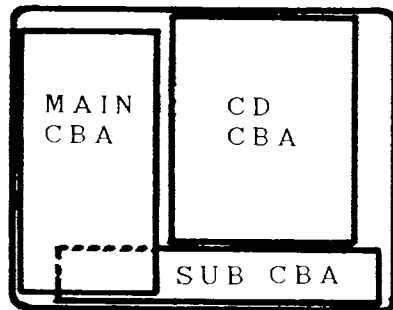

MEGA CD2/SEGA CD2 (FUNAI)

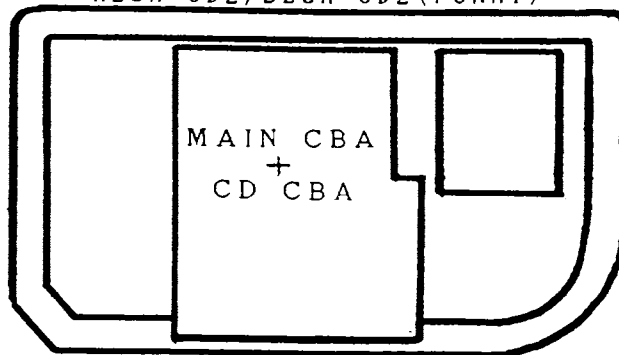

# MEGA-CD2/SEGA-CD2 PICKUP UNITS

1) MEGA-CD2/SEGA-CD2 pickup units

- ① KSS-210A
- ② SOHOT4

2) How to discriminate

Check the label indication to discriminate the pickup units (see the figure below).

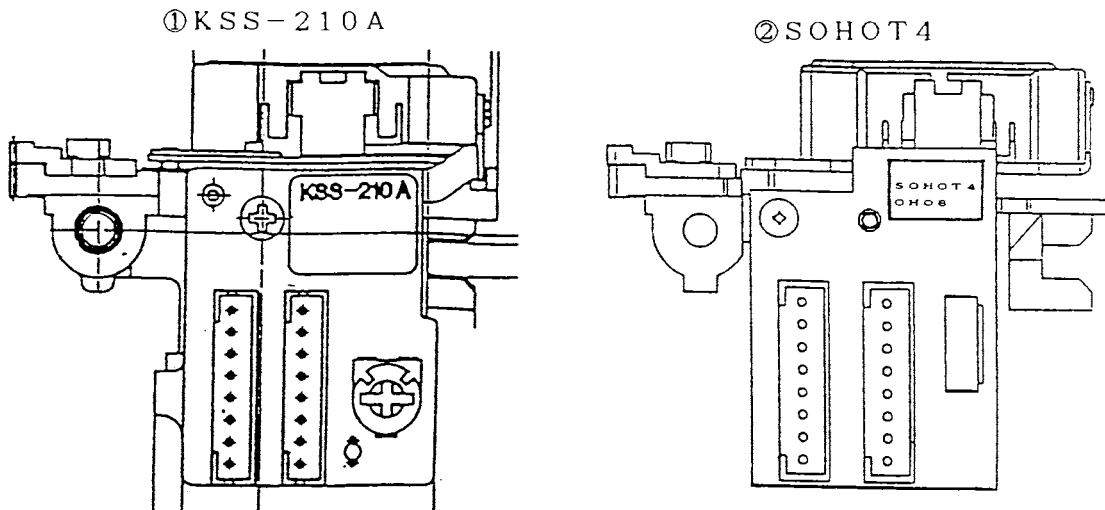

3) Differences of electrical parts between KSS-210A and SOHOT4

The KSS-210A and SOHOT4 use the different electrical parts (see Table below).

Circuit No.	① KSS-210A	② SOHOT4
Chip Resistors		
R414	1.8 kohm	2.2 kohm
R421	220 kohm	87 kohm
R422	150 kohm	Not used
R423	220 kohm	270 kohm
R424	15 kohm	20 kohm
R426	4.7 kohm	3.3 kohm
R448	91 ohm	82 ohm
R449	10 kohm	0 ohm
R450	33 kohm	Not used
R491	150 kohm	180 kohm
Chip Capacitors		
C428	0.056 $\mu$ F	Not used
C451	15 pF	8 pF
Electrolytic Capacitor		
C412	22 $\mu$ F/6.3 V	47 $\mu$ F/6.3 V
Mechanism Assembly	CD-775	CD-776
IC900 Heat Sink	Heat Sink 2 MEGA CD2	Heat Sink SPL 1

4) Tracking gain adjustment value

The KSS-210A and SOHOT4 have different tracking gain adjustment values (see Table below).

	KSS-210A	SOHOT4
Tracking gain adjustment value	1 kHz/0 dB	800 Hz/0 dB

## Differences in MEGA-CD2/SEGA-CD2 between Works in China and Japan

Item	Works in Japan	Works in China
Package size of all chip resistors and capacitors	1.6 x 0.8 mm	2 x 1.25 mm
PCM board	Yes	Integrated with main board
IC952 (74 AC 74)	No	Yes
C951	No	Yes
C952	No	Yes



Main parameters :

- |   |  |
|---|--|
| (1) playing time<br>single side, 2 channels     | approx. 60 min.                          |
| (2) scanning velocity<br>(2 channels)           | 1.2 - 1.4 m/s                            |
| (3) sense of rotation seen<br>from reading side | counter clockwise                        |
| (4) track pitch                                 | 1.6 $\mu\text{m}$                        |
| (5) diameter of the disc                        | 120 mm                                   |
| (6) thickness of the disc                       | 1.2 mm                                   |
| (7) diameter of centre hole                     | 15 mm                                    |
| (8) starting diameter of<br>program area        | 50 mm                                    |
| (9) number of channels                          | 2 and/or 4 simultaneously sampled        |
| (10) sampling frequency                         | 44.1 KHz                                 |
| (11) quantization                               | 16 bits linear/channel<br>2's complement |
| (12) channel bit rate                           | 4.3218 Mb/s $\checkmark$ CC              |
| (13) pre emphasis                               | no or 50/15 $\mu\text{s}$                |



DISC SPECIFICATION

1. Outer diameter

1.1. outer diameter of disc  $120 \pm 0.3 \text{ mm}$

2. Centre hole

2.1. diameter  $15 - 0 \text{ mm}$

RECORDED AREA

3. Recorded area

3.1. starting diameter of program area  $50 - 0 \text{ mm}$

3.2. max. diameter of program area  $116 \text{ mm}$

3.3. max. starting diameter of lead-in area  $46 \text{ mm}$

3.4. min. outer diameter of lead out area  $\text{outer diameter of program area plus } 1 \text{ mm}$

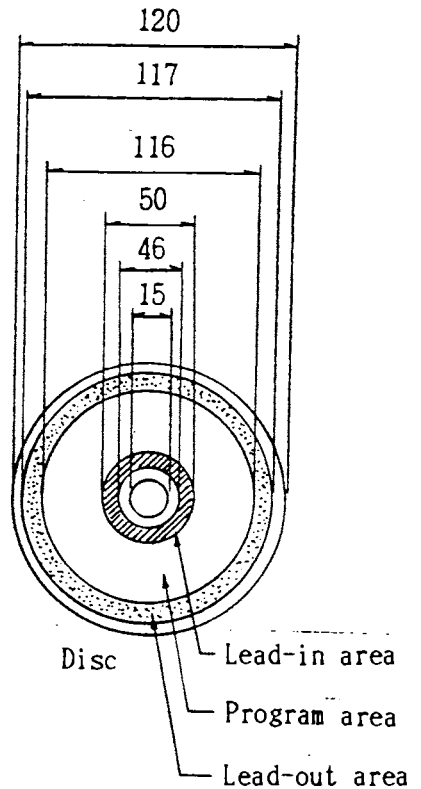

4. Track pitch

4.1. track pitch  $1.6 \pm 0.1 \mu\text{m}$   
 pit width  $0.4 \sim 0.5 \mu\text{m}$   
 pit depth  $110 \text{ nm}$

$$T = \frac{1.25 \times 10^6 (\mu\text{m/s})}{4.3218 \times 10^6 (\text{Hz})} \approx 0.29 (\mu\text{m})$$

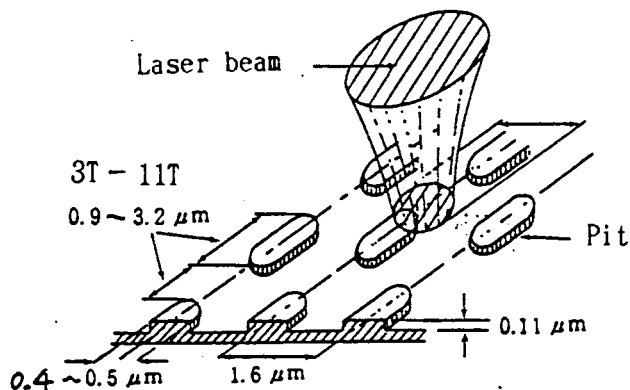

5. Rotation

5.1. sense of rotation  $\text{counter clockwise}$

5.2. scanning velocity  $1.20 - 1.40 \text{ m/s}$

6. max. vert. deviation  $\pm 0.5 \text{ mm}$

7. max eccentricity of track radius  $\pm 70 \mu\text{m}$

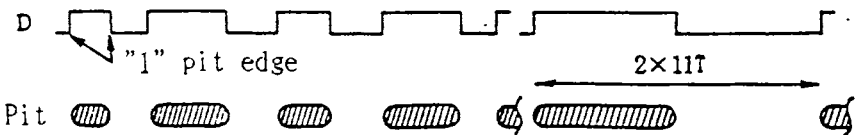
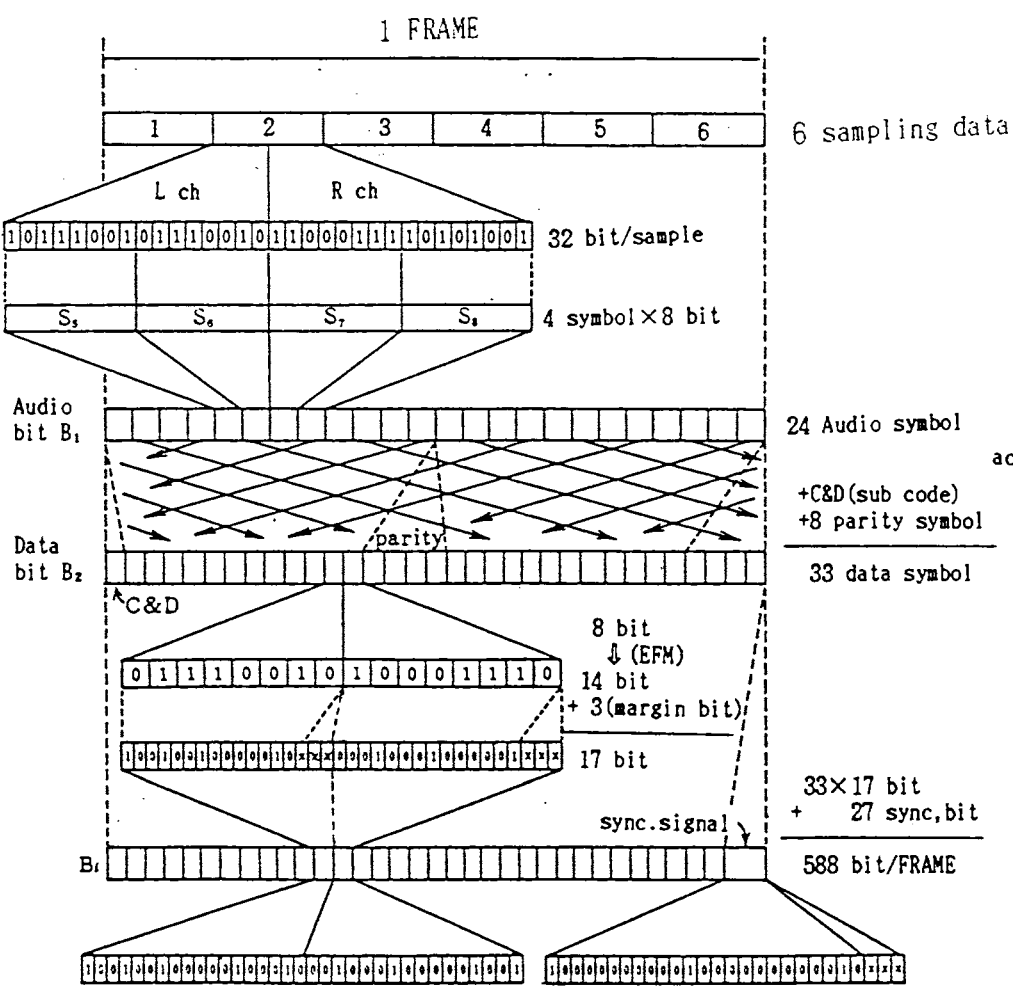
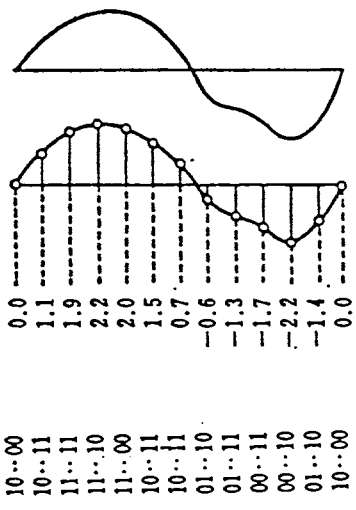
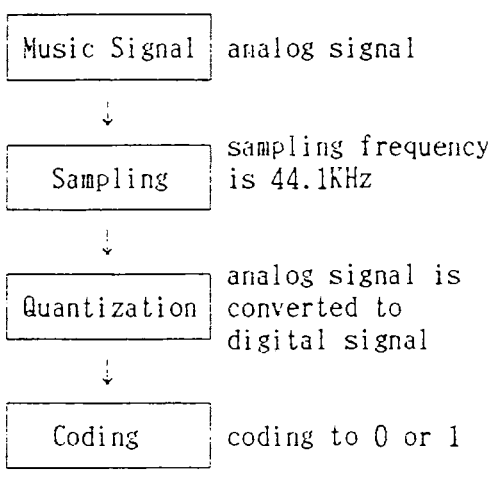

Frame format

CONTROL AND DISPLAY SYSTEM.  
subcoding block

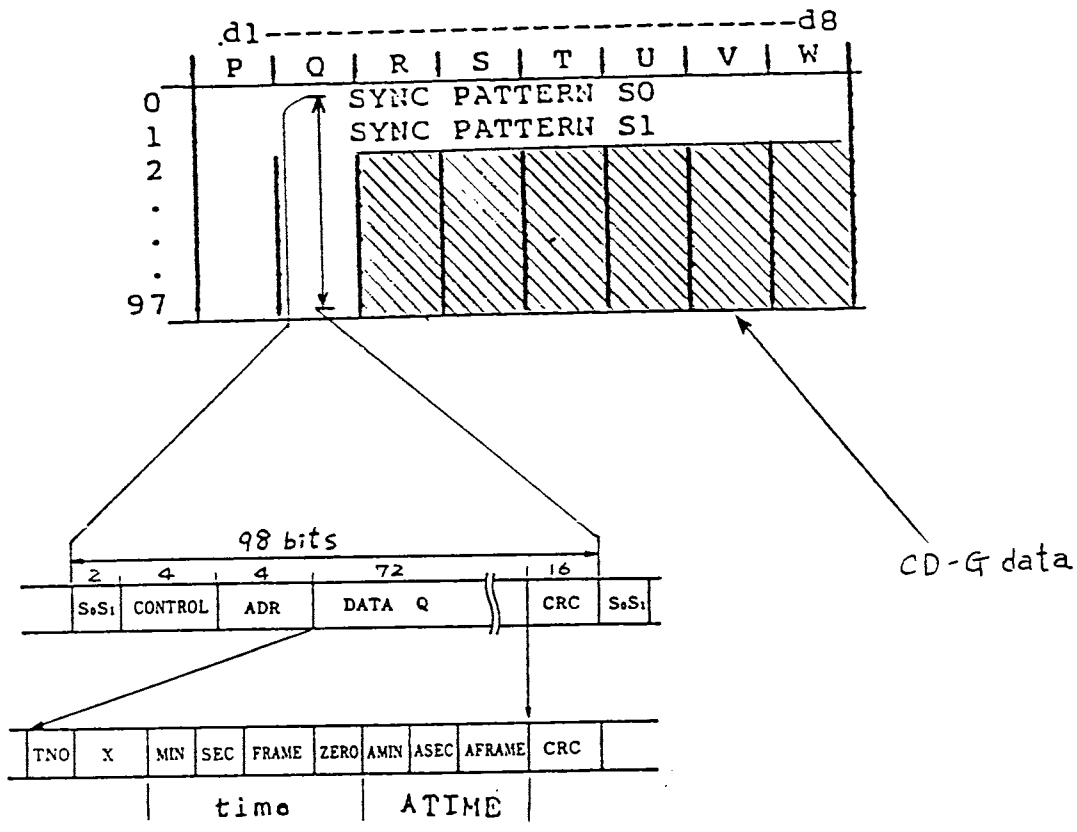

EXAMPLE OF ENCODING IN CHANNEL P AND Q

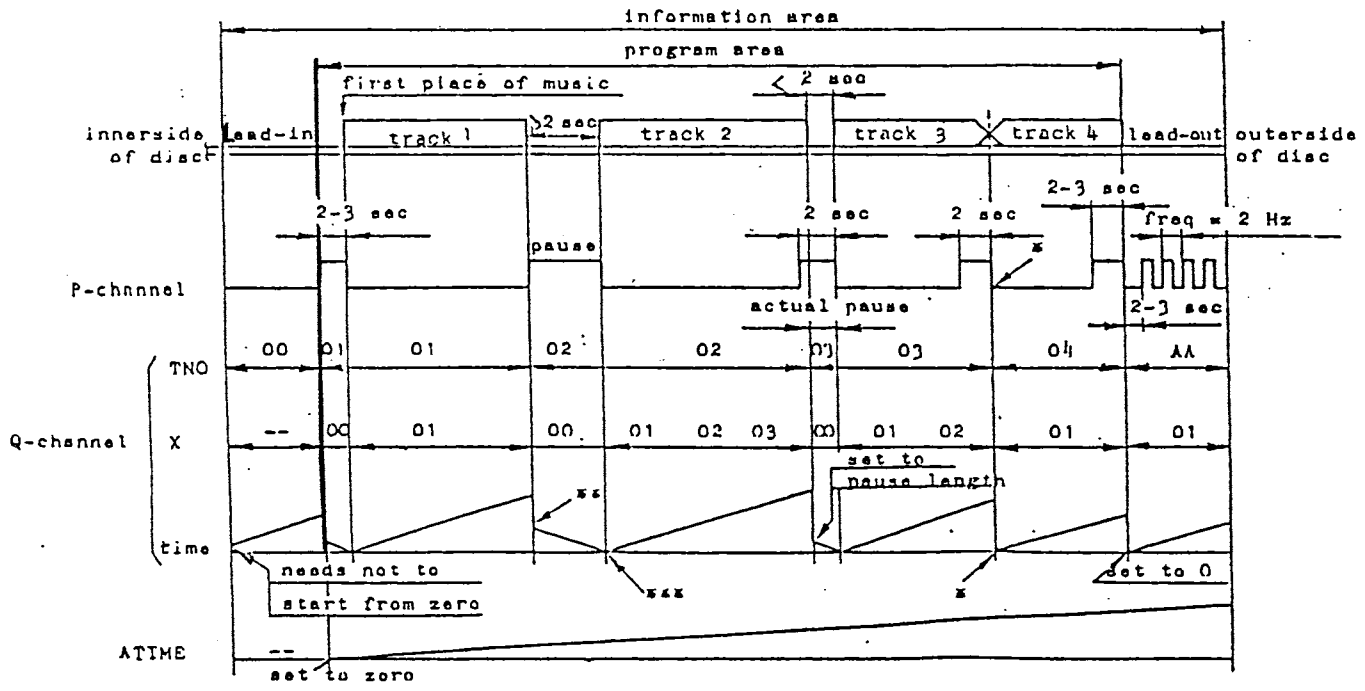





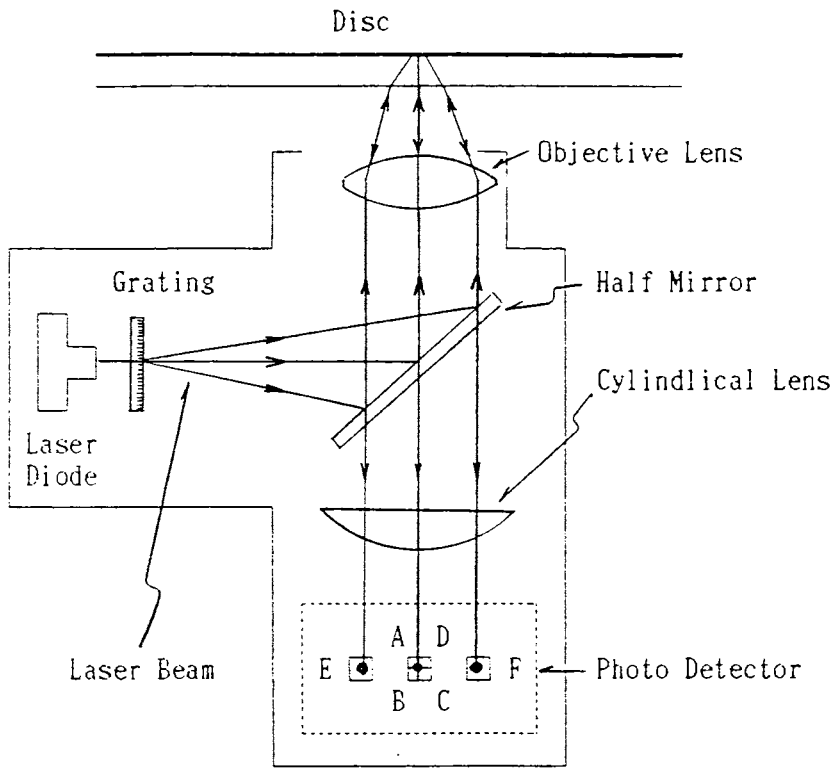

### 3-Beam Pick Up Unit

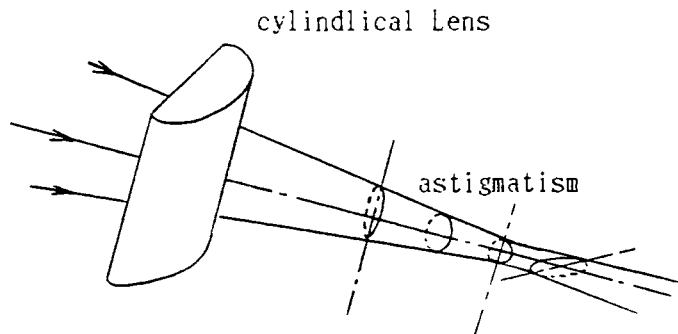

#### (i) Focus Error Detection



-  . . . near Disc
-  . . . just Focus
-  . . . far Disc

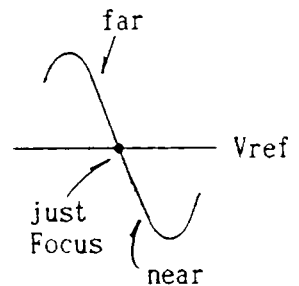
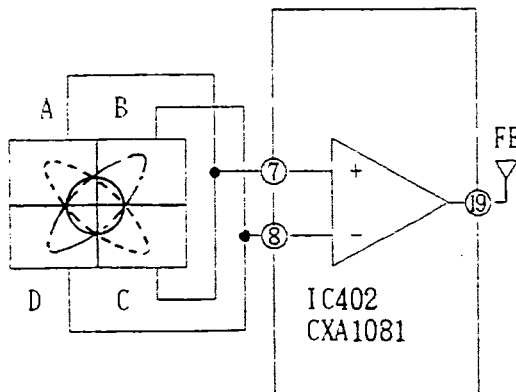

(2) Tracking Error Detection

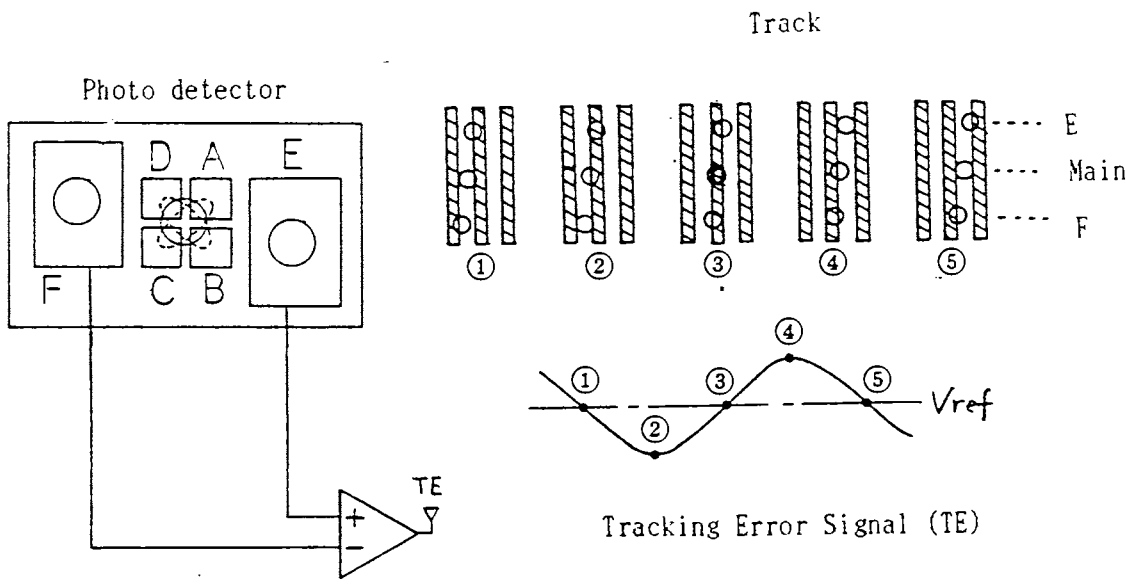
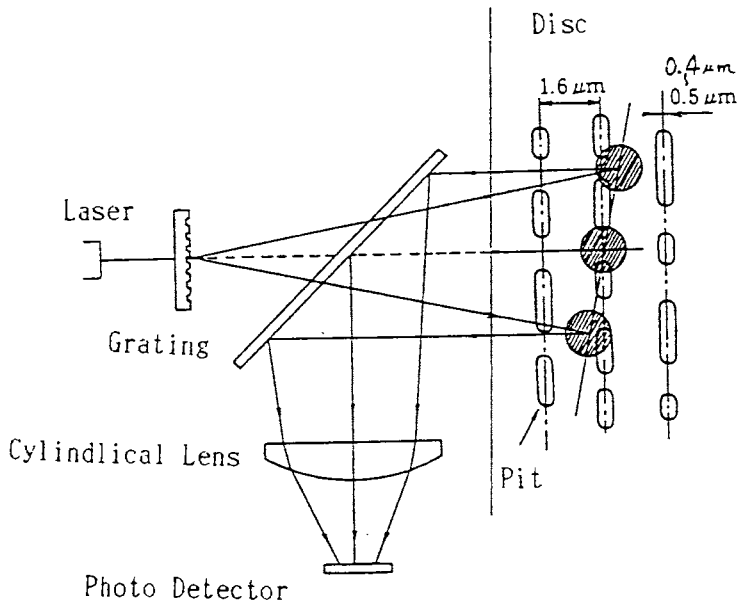

EF balance adjustment

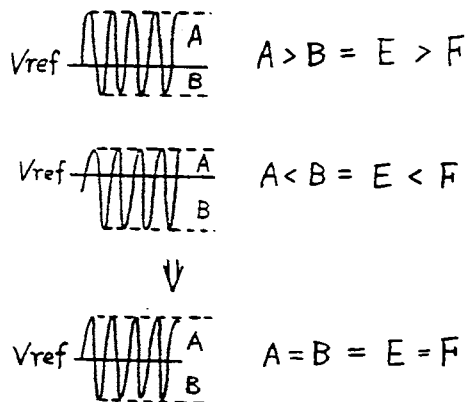
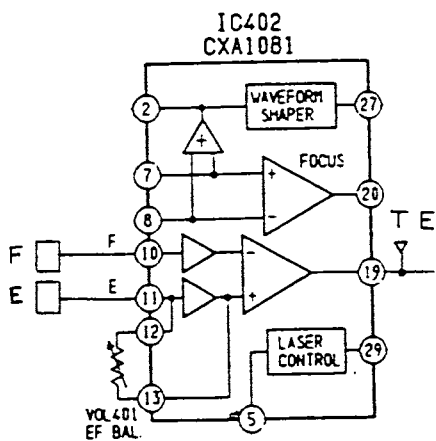

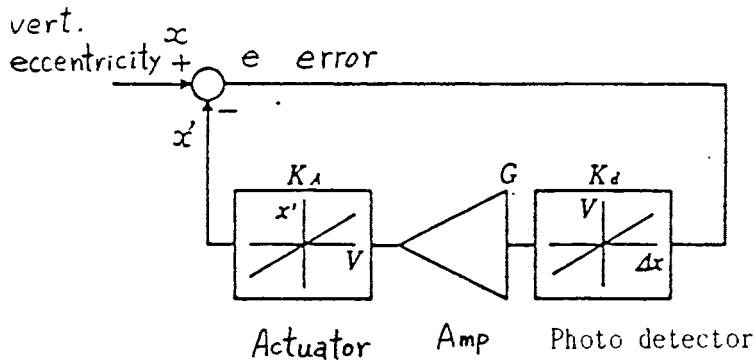
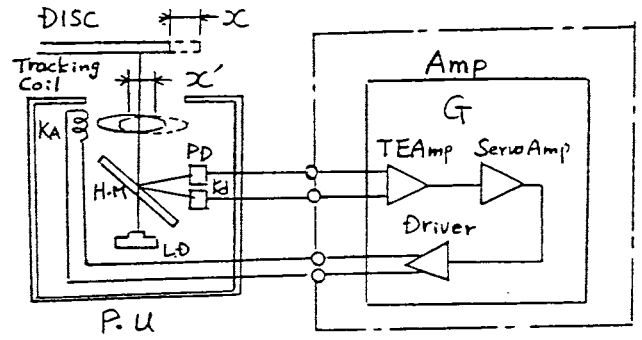
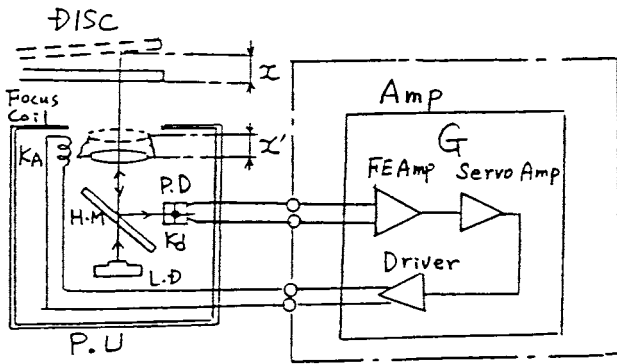

(1) Focus servo

focal depth  $\pm 1.9 \mu\text{m}$   $\Rightarrow$  error  $< \pm 1.0 \mu\text{m}$

(2) Tracking servo

pit width  $\pm 0.2 \mu\text{m}$   $\Rightarrow$  error  $< \pm 0.1 \mu\text{m}$