

**SONY**<sup>®</sup>

TRINITRON<sup>®</sup> COLOR VIDEO MONITOR

**BVM-D9H1A** CHASSIS NO. SCC-P31C-A

**BVM-D9H1E** CHASSIS NO. SCC-G10D-A

**BVM-D9H1U** CHASSIS NO. SCC-G09F-A

**BVM-D9H5A** CHASSIS NO. SCC-P31F-A

**BVM-D9H5E** CHASSIS NO. SCC-G10G-A

**BVM-D9H5U** CHASSIS NO. SCC-G09G-A



***Multiformat***

MAINTENANCE MANUAL

1st Edition

Serial No. 2000001 and Higher (ALL MODELS)

## **⚠ WARNING**

This manual is intended for qualified service personnel only.

To reduce the risk of electric shock, fire or injury, do not perform any servicing other than that contained in the operating instructions unless you are qualified to do so. Refer all servicing to qualified service personnel.

## **⚠ WARNUNG**

Die Anleitung ist nur für qualifiziertes Fachpersonal bestimmt.

Alle Wartungsarbeiten dürfen nur von qualifiziertem Fachpersonal ausgeführt werden. Um die Gefahr eines elektrischen Schlages, Feuergefahr und Verletzungen zu vermeiden, sind bei Wartungsarbeiten strikt die Angaben in der Anleitung zu befolgen. Andere als die angegebenen Wartungsarbeiten dürfen nur von Personen ausgeführt werden, die eine spezielle Befähigung dazu besitzen.

## **⚠ AVERTISSEMENT**

Ce manuel est destiné uniquement aux personnes compétentes en charge de l'entretien. Afin de réduire les risques de décharge électrique, d'incendie ou de blessure n'effectuer que les réparations indiquées dans le mode d'emploi à moins d'être qualifié pour en effectuer d'autres. Pour toute réparation faire appel à une personne compétente uniquement.

### **WARNING!!**

**AN INSULATED TRANSFORMER SHOULD BE USED DURING ANY SERVICE TO AVOID POSSIBLE SHOCK HAZARD, BECAUSE OF LIVE CHASSIS. THE CHASSIS OF THIS RECEIVER IS DIRECTLY CONNECTED TO THE AC POWER LINE.**

### **SAFETY-RELATED COMPONENT WARNING !!**

**COMPONENTS IDENTIFIED BY A ⚠ MARK ON THE SCHEMATIC DIAGRAMS, EXPLODED VIEWS AND IN THE PARTS LIST ARE CRITICAL TO SAFE OPERATION. REPLACE THESE COMPONENTS WITH SONY PARTS WHOSE PART NUMBERS APPEAR AS SHOWN IN THIS MANUAL OR IN SUPPLEMENTS PUBLISHED BY SONY. CIRCUIT ADJUSTMENTS THAT ARE CRITICAL TO SAFE OPERATION ARE IDENTIFIED IN THIS MANUAL. FOLLOW THESE PROCEDURES WHENEVER CRITICAL COMPONENTS ARE REPLACED OR IMPROPER OPERATION IS SUSPECTED.**

### **ATTENTION!!**

**AFIN D'ÉVITER TOUT RISQUE D'ÉLECTROCUTION PROVENANT D'UN CHÂSSIS SOUS TENSION, UN TRANSFORMATEUR D'ISOLEMENT DOIT ÊTRE UTILISÉ LORS DE TOUT DÉPANNAGE. LE CHÂSSIS DE CE RÉCEPTEUR EST DIRECTEMENT RACCORDÉ À L'ALIMENTATION SECTEUR.**

### **ATTENTION AUX COMPOSANTS RELATIFS À LA SÉCURITÉ!!**

**LES COMPOSANTS IDENTIFIÉS PAR UNE MAPQUE ⚠ SUR LES SCHÉMAS DE PRINCIPE, LES VUES EXPLOSÉES ET LES LISTES DE PIÈCES SONT D'UNE IMPORTANCE CRITIQUE POUR LA SÉCURITÉ DU FONCTIONNEMENT. NE LES REMPLACER QUE PAR DES COMPOSANTS SONY DONT LE NUMÉRO DE PIÈCE EST INDIQUÉ DANS LE PRÉSENT MANUEL OU DANS DES SUPPLÉMENTS PUBLIÉS PAR SONY. LES RÉGLAGES DE CIRCUIT DONT L'IMPORTANCE EST CRITIQUE POUR LA SÉCURITÉ DU FONCTIONNEMENT SONT IDENTIFIÉS DANS LE PRÉSENT MANUEL. SUIVRE CES PROCÉDURES LORS DE CHAQUE REMPLACEMENT DE COMPOSANTS CRITIQUES, OU LORSQU'UN MAUVAIS FONCTIONNEMENT EST SUSPECTÉ.**

# Table of Contents

## 1. Operating Instructions

BVM-D9H1J/D9H1U/D9H1E/D9H1A/D9H5J/D9H5U/D9H5E/D9H5A D14H1J/D14H1U/D14H1E/D14H1A/D14H5J/D14H5U/D14H5E/D14H5A .....	1-1
---	-----

## 2. Service Informations

2-1. Circuit Boards Location (1/2) .....	2-1
2-2. Circuit Boards Location (2/2) .....	2-1
2-2-1. Cabinet Assy Removal .....	2-2
2-2-2. Control Panel Complete Assy Removal (D9H5) .....	2-3
2-2-3. HA and HB Boards Removal (D9H5) .....	2-3
2-2-4. HC and HD Boards Removal (D9H5) .....	2-4
2-2-5. YA and YB Boards Removal .....	2-4
2-2-6. B, B1 and B2 Boards Removal .....	2-5
2-2-7. How to Open D Board .....	2-5
2-2-8. P Board Removal .....	2-6
2-2-9. BX Board (BKM-129X) Removal and Check .....	2-7
2-2-10. T Board Removal .....	2-8
2-2-11. M Block Assy (MA and MB Boards) Removal .....	2-8
2-2-12. G Board Removal .....	2-9
2-2-13. Picture Tube Removal .....	2-10

## 3. Set-Up Adjustments

3-1. Set-Up Adjustment When CRT is Replaced .....	3-1
[Focus Adjustment] .....	3-3
[Landing Adjustment] .....	3-3
[H. Blanking Adjustment] .....	3-4
[V. Blanking Adjustment] .....	3-6
[Linearity Adjustment] .....	3-6
[Convergence Adjustment] .....	3-8
[Static Convergence Adjustment] .....	3-9
[Dynamic Convergence Adjustment] .....	3-9
[G2 Adjustment] .....	3-10
[White Balance Adjustment] .....	3-10

## 4. Safety Related Adjustments

+B (12 V) Voltage Check .....	4-2
High Voltage Regulator Check .....	4-2
High Voltage Hold-Down Check .....	4-3
ABL Check .....	4-3
Beam Current Protector Check .....	4-4

## 5. Circuit Adjustments

5-1. B Board Adjustments .....	5-1
1. RGB Signal Adjustment .....	5-2
2. 15k YPBPR SMPTE (709) Signal Adjustment .....	5-3
3. 15k YPBPR SMPTE (601) Signal Adjustment .....	5-5
4. 15k YPBPR BETACAM SETUP 0 (601) Signal Adjustment ...	5-6
5. 15k YPBPR BETACAM SETUP 7.5 (601) Signal Adjustment	5-7
6. 33k YPBPR SMPTE (709) Signal Adjustment .....	5-8

## 6. Circuit Descriptions

6-1. G Board .....	6-1
6-2. B Board .....	6-2
6-3. MA Board .....	6-3
6-4. MB Board .....	6-3
6-5. D Board P1 and P2 .....	6-4
6-6. P Board .....	6-6
6-7. HA, HB and HC Boards .....	6-8
6-8. HD Board .....	6-8

## 7. Semiconductors ..... 7-1

## 8. Exploded Views

8-1. Chassis .....	8-1
8-2. Picture Tube .....	8-2
8-3. Power Unit .....	8-3

## 9. Electrical Parts List ..... 9-1

## 10. Block Diagrams

Overall (1/2) .....	10-1
Overall (2/2) .....	10-2
BC (1/2), BX, B1, B2 .....	10-3
BC (2/2), C .....	10-4
D (1/2) .....	10-5
D (2/2), G1 .....	10-6
P .....	10-7
MA, MB .....	10-8
HA, HB, HC .....	10-9

## 11. Diagrams

11-1. Frame Schematic Diagram .....	11-2
Frame .....	11-2
11-2. Schematic Diagrams and Printed Wiring Boards .....	11-3
Schematic Diagrams	
BX (1/2) .....	11-4
BX (2/2) .....	11-5
B (1/4) .....	11-7
B (2/4) .....	11-8
B (3/4) .....	11-9
B (4/4) .....	11-10
B1 .....	11-12
B2 .....	11-13
G .....	11-15
C .....	11-17
D (1/2) .....	11-19
D (2/2) .....	11-20
MA .....	11-23
MB .....	11-25
P .....	11-29
HA, HB .....	11-31
HD .....	11-32
YA, YB .....	11-33
HC .....	11-35
T .....	11-36

Printed Wiring Boards

BX	.....	11-3
B	.....	11-6
B1	.....	11-12
B2	.....	11-13
G	.....	11-14
C	.....	11-17
D	.....	11-18
MA	.....	11-22
MB	.....	11-24
P	.....	11-28
HA, HB, HD	.....	11-30
YA, YB	.....	11-33
HC	.....	11-34
T	.....	11-36

**Section 1**  
**Operating Instructions**

This section is extracted from  
operation manual.

**SONY®**

TRINITRON® COLOR VIDEO MONITOR

**BVM-D9H1J/D9H1U/D9H1E/D9H1A**

**BVM-D9H5J/D9H5U/D9H5E/D9H5A**

**BVM-D14H1J/D14H1U/D14H1E/D14H1A**

**BVM-D14H5J/D14H5U/D14H5E/D14H5A**



***Multiformat***

OPERATION MANUAL Japanese/English

1st Edition

Serial No. 2000001 and Higher

**WARNING**

To prevent fire or shock hazard, do not expose the unit to rain or moisture.

To avoid electrical shock, do not open the cabinet. Refer servicing to qualified personnel only.

**AVERTISSEMENT**

Afin d'éviter tout risque d'incendie ou d'électrocution, ne pas exposer cet appareil à la pluie ou à l'humidité.

Afin d'éviter tout risque d'électrocution, garder le coffret fermé. Ne confier l'entretien de l'appareil qu'à un personnel qualifié.

**WARNING**

Um Feuergefahr und die Gefahr eines elektrischen Schlages zu vermeiden, darf das Gerät weder Regen noch Feuchtigkeit ausgesetzt werden.

Um einen elektrischen Schlag zu vermeiden, darf das Gehäuse nicht geöffnet werden. Überlassen Sie Wartungsarbeiten stets nur einem Fachmann.

**ADVERTENCIA**

Para evitar incendios o el riesgo de electrocución, no exponga la unidad a la lluvia ni a la humedad.

Para evitar descargas eléctricas, no abra la unidad. En caso de avería, solicite los servicios de personal cualificado.

**ATTENZIONE**

Per evitare incendi o cortocircuiti, l'apparecchio non deve essere esposto alla pioggia o all'umidità.

Per evitare scosse elettriche, non aprite l'apparecchio. Per le riparazioni rivolgetevi solo a personale qualificato.

**CAUTION:**

Danger of explosion if battery is incorrectly replaced. Replace only with the same or equivalent type recommended by the manufacturer. Discard used batteries according to the manufacturer's instructions.

**ATTENTION**

Il y a un risque d'explosion si la pile est mal insérée. Remplacer la pile uniquement par une pile de même type ou de type équivalent recommandé par le fabricant. Jeter les piles usées conformément aux instructions du fabricant.

**VORSICHT:**

Es besteht Explosionsgefahr, wenn die Batterie inkorrekt eingelegt wird. Es darf nur eine identische oder eine vom Hersteller empfohlene Batterie des gleichen Typs eingesetzt werden. Entladene Batterien sind nach den Anweisungen des Herstellers zu entsorgen.

**PRECAUCION**

Peligro de explosión en caso de haberse instalado incorrectamente la batería. Cambie sólo por una del mismo tipo o especificaciones equivalentes, de entre las recomendadas por el fabricante. Las baterías viejas se deben eliminar siguiendo las instrucciones del fabricante.

**ATTENZIONE:**

Pericolo di esplosione se la pila viene sostituita scorrettamente. Sostituirla solo con un'altra uguale o di un tipo equivalente consigliato dal fabbricante. Gettare via le pile usate secondo le istruzioni del fabbricante.

**Note**

The socket-outlet should be installed near the equipment and be easily accessible.

**Remarque**

La prise doit être près de l'appareil et facile d'accès.

**Hinweis**

Zur Trennung vom Netz ist der Netzstecker aus der Steckdose zu ziehen, welche sich in der Nähe des Gerätes befinden muß und leicht zugänglich sein soll.

**Nota**

La toma mural debe estar instalada cerca del equipo y debe accederse a ésta con facilidad.

**Nota**

La presa di corrente deve essere situata vicino all'apparecchio o deve essere facilmente accessibile.

**For customers in the USA****(BVM-D9H1U/D9H5U, BVM-D14H1U/D14H5U)**

This equipment has been tested and found to comply with the limits for a Class A digital device, pursuant to Part 15 of the FCC Rules. These limits are designed to provide reasonable protection against harmful interference when the equipment is operated in a commercial environment. This equipment generates, uses, and can radiate radio frequency energy and, if not installed and used in accordance with the instruction manual, may cause harmful interference to radio communications. Operation of this equipment in a residential area is likely to cause harmful interference in which case the user will be required to correct the interference at his own expense.

You are cautioned that any changes or modifications not expressly approved in this manual could void your authority to operate this equipment.

The shielded interface cable recommended in this manual must be used with this equipment in order to comply with the limits for a digital device pursuant to Subpart B of Part 15 of FCC Rules.

**Für Kunden in Deutschland**

Entsorgungshinweis: Bitte werfen Sie nur entladene Batterien in die Sammelboxen beim Handel oder den Kommunen. Entladen sind Batterien in der Regel dann, wenn das Gerät abschaltet und signalisiert "Batterie leer" oder nach längerer Gebrauchsdauer der Batterien "nicht mehr einwandfrei funktioniert". Um sicherzugehen, kleben Sie die Batteriepole z.B. mit einem Klebestreifen ab oder geben Sie die Batterien einzeln in einen Plastikbeutel.

**Voor de klanten in Nederland**

Bij dit produkt zijn batterijen geleverd. Wanneer deze leeg zijn, moet u ze niet weggoien maar inleveren als KCA.

- Dit apparaat bevat een Li-ion batterij voor memory back-up.
- De batterij voor memory back-up is vastgesoldeerd op de MA printplaat BT1.
- Raadpleeg uw leverancier over de verwijdering van de batterij op het moment dat u het apparaat bij einde levensduur afdankt.
- Gooi de batterij niet weg, maar lever hem in als KCA.

**För kunderna i Sverige**

Apparaten ma kun tilkoples jordet stikkontakt

**For kunder i Norge**

Apparatet må kun tilkoples jordet stikkontakt

**For the customers in Europe****(BVM-D9H1E/D9H1A/D9H5E/D9H5A, BVM-D14H1E/D14H1A/D14H5E/D14H5A)**

This product with the CE marking complies with both the EMC Directive (89/336/EEC) and the Low Voltage Directive (73/23/EEC) issued by the Commission of the European Community.

Compliance with these directives implies conformity to the following European standards:

- EN60950: Product Safety
- EN55103-1: Electromagnetic Interference (Emission)
- EN55103-2: Electromagnetic Susceptibility (Immunity)

This product is intended for use in the following Electromagnetic Environment(s): E1 (residential), E2 (commercial and light industrial), E3 (urban outdoors) and E4 (controlled EMC environment, ex. TV studio).

**Pour les clients européens****(BVM-D9H1E/D9H1A/D9H5E/D9H5A, BVM-D14H1E/D14H1A/D14H5E/D14H5A)**

Ce produit portant la marque CE est conforme à la fois à la Directive sur la compatibilité électromagnétique (EMC) (89/336/CEE) et à la Directive sur les basses tensions (73/23/CEE) émises par la Commission de la Communauté européenne.

La conformité à ces directives implique la conformité aux normes européennes suivantes:

- EN60950: Sécurité des produits
- EN55103-1: Interférences électromagnétiques (émission)
- EN55103-2: Sensibilité électromagnétique (immunité)

Ce produit est prévu pour être utilisé dans les environnements électromagnétiques suivants: E1 (résidentiel), E2 (commercial et industrie légère), E3 (urbain extérieur) et E4 (environnement EMC contrôlé ex. studio de télévision).

**Für Kunden in Europa****(BVM-D9H1E/D9H1A/D9H5E/D9H5A, BVM-D14H1E/D14H1A/D14H5E/D14H5A)**

Dieses Produkt besitzt die CE-Kennzeichnung und erfüllt sowohl die EMV-Direktive (89/336/EEC) als auch die Direktive Niederspannung (73/23/EEC) der EG-Kommission.

Die Erfüllung dieser Direktiven bedeutet Konformität für die folgenden Europäischen Normen:

- EN60950: Produktsicherheit
- EN55103-1: Elektromagnetische Interferenz (Emission)
- EN55103-2: Elektromagnetische Empfindlichkeit (Immunität)

Dieses Produkt ist für den Einsatz unter folgenden elektromagnetischen Bedingungen ausgelegt:

E1 (Wohnbereich), E2 (kommerzieller und in beschränktem Maße industrieller Bereich), E3 (Stadtbereich im Freien) und E4 (kontrollierter EMV-Bereich, z.B. Fernsehstudio)



**ATTENTION - When the product is installed in a rack:**

- a) Elevated operating ambient temperature**  
If installed in a closed or multi-unit rack assembly, the operating ambient temperature of the rack environment may be greater than room ambient. Therefore, consideration should be given to installing the equipment in an environment compatible with the manufacture's maximum rated ambient temperature (T<sub>mra</sub>: 0°C to 35°C (32°F to 95°F)).
- b) Reduced air flow**  
Installation of the equipment in a rack should be such that the amount of air flow required for safe operation of the equipment is not compromised.
- c) Mechanical loading**  
Mounting of the equipment in the rack should be such that a hazardous condition is not achieved due to uneven mechanical loading.
- d) Circuit overloading**  
Consideration should be given to the connection of the equipment to the supply circuit and the effect that overloading of circuits might have on overcurrent protection and supply wiring. Appropriate consideration of equipment nameplate ratings should be used when addressing this concern.
- e) Reliable earthing**  
Reliable earthing of rack-mounted equipment should be maintained. Particular attention should be given to supply connections other than direct connections to the branch circuit (e.g., use of power strips).
- f) Gap keeping**  
Upper and lower gap of rack-mounted equipment should be kept at least 44 mm (1 3/4 inches).

**For the customers in the United Kingdom  
(BVM-D9H1E/D9H1A/D9H5E/D9H5A, BVM-D14H1E/  
D14H1A/D14H5E/D14H5A)**

**WARNING**  
**THIS APPARATUS MUST BE EARTHED**

**IMPORTANT**

The wires in this mains lead are coloured in accordance with the following code:

Green-and-yellow:	Earth
Blue:	Neutral
Brown:	Live

As the colours of the wires in the mains lead of this apparatus may not correspond with the coloured markings identifying the terminals in your plug proceed as follows:  
The wire which is coloured green-and-yellow must be connected to the terminal in the plug which is marked by the letter E or by the safety earth symbol  $\perp$  or coloured green or green-and-yellow.

The wire which is coloured blue must be connected to the terminal which is marked with the letter N or coloured black.  
The wire which is coloured brown must be connected to the terminal which is marked with the letter L or coloured red.

Ensure that your equipment is connected correctly - if you are in any doubt consult a qualified electrician.

**Achtung - bei Installation des Geräts in einem Gestell:**

- a) Erhöhte Umgebungstemperatur bei Betrieb**  
Wird das Gerät in einem geschlossenen Gestell oder einem Gestell mit mehreren anderen Geräten installiert, kann die Umgebungstemperatur um das Gestell höher sein als die normale Umgebungstemperatur im Raum. Achten Sie daher bitte besonders darauf, das Gerät in einer Umgebung zu installieren, in der die Temperatur nicht über die vom Hersteller angegebene Umgebungstemperatur von 0 bis 35 °C (32 °F bis 95 °F) ansteigt (T<sub>mra</sub>).
- b) Reduzierte Belüftung**  
Das Gerät muß so im Gestell installiert werden, daß eine Belüftung gewährleistet ist, die für den sicheren Betrieb des Geräts erforderlich ist.
- c) Mechanische Belastung**  
Das Gerät muß so im Gestell installiert werden, daß nicht durch eine ungleichmäßige mechanische Belastung Unfallgefahr entsteht.
- d) Überlastung der Stromkreise**  
Der Anschluß des Geräts an das Versorgungsnetz erfordert sorgfältige Planung. Bitte beachten Sie insbesondere die Auswirkungen, die eine Überlastung der Stromkreise im Hinblick auf den Überspannungsschutz und die physischen Komponenten des Versorgungsnetzes haben kann. Beachten Sie in diesem Zusammenhang unbedingt die Angaben auf dem Typenschild am Gerät.
- e) Zuverlässige Erdung**  
Geräte, die in einem Gestell installiert werden, benötigen eine zuverlässige Erdung. Achten Sie insbesondere auf Anschlüsse an das Versorgungsnetz, die nicht direkt an einen Abzweigstromkreis, sondern indirekt, zum Beispiel über Verlängerungskabel, erfolgen.
- f) Erforderliche Abstände**  
Halten Sie zur Ober- und Unterseite eines in einem Gestell installierten Geräts einen Abstand von 44 mm (1 3/4 inches) ein.

# Table of Contents

## Chapter 1 Overview

Precautions .....	3(E)
Overview .....	4(E)
Features .....	4(E)
Options .....	5(E)
<b>Location and Function of Parts .....</b>	<b>7(E)</b>
BVM-D9H1U/D9H1E/D9H1A/D9H5U/D9H5E/D9H5A Front Panel .....	7(E)
BVM-D9H1U/D9H1E/D9H1A/D9H5U/D9H5E/D9H5A Rear Panel .....	12(E)
BVM-D14H1U/D14H1E/D14H1A/D14H5U/D14H5E/D14H5A Front Panel .....	16(E)
BVM-D14H1U/D14H1E/D14H1A/D14H5U/D14H5E/D14H5A Rear Panel .....	21(E)
<b>Installation of the 4:3 Mask .....</b>	<b>24(E)</b>
BVM-D9H1U/D9H1E/D9H1A/ D9H5U/D9H5E/D9H5A .....	24(E)
BVM-D14H1U/D14H1E/D14H1A/ D14H5U/D14H5E/D14H5A .....	24(E)

## Chapter 2 Menu

<b>Basic Menu Operations .....</b>	<b>25(E)</b>
Menu Operation Buttons .....	25(E)
Displaying the Menus .....	26(E)
Menu Operation .....	26(E)
ADDRESS Menu .....	29(E)
<b>Menu Structure .....</b>	<b>30(E)</b>
<b>A Preset Adjustment of the Picture Level Control Knobs</b>	
— CONTROL PRESET ADJ Menu .....	31(E)
Overview .....	31(E)
Structure of the CONTROL PRESET ADJ Menu .....	31(E)
Setting Lists in the CONTROL PRESET ADJ Menu .....	31(E)
<b>B Adjusting the Color Temperature</b>	
— COLOR TEMP ADJ Menu .....	33(E)
Overview .....	33(E)
Structure of the COLOR TEMP ADJ Menu .....	33(E)
Setting Lists in the COLOR TEMP ADJ Menu .....	34(E)
<b>C Setting the Input Configuration</b>	
— INPUT CONFIG Menu .....	35(E)
Overview .....	35(E)
Structure of the INPUT CONFIG Menu .....	35(E)
Setting Lists in the INPUT CONFIG Menu .....	36(E)
<b>D Assigning the Remote Control Functions</b>	
— REMOTE Menu .....	37(E)
Overview .....	37(E)
Structure of the REMOTE Menu .....	37(E)
Setting Lists of the REMOTE Menu .....	38(E)

(Continued)

## Table of contents

Chapter 2  
Menu

<b>E</b> Setting the Power-Up Conditions and Data about the Screen Display — SYSTEM CONFIG Menu .....	39(E)
Overview .....	39(E)
Structure of the SYSTEM CONFIG Menu .....	40(E)
Setting Lists of the SYSTEM CONFIG Menu .....	40(E)
<b>F</b> Displaying Information About the Monitor	
— STATUS Menu .....	42(E)
Overview .....	42(E)
Structure of the STATUS Menu .....	42(E)
Setting Lists of the STATUS Menu .....	42(E)
<b>G</b> Adjusting the Position, Size and Geometry of the Picture	
— ALIGNMENT Menu .....	43(E)
Overview .....	43(E)
Structure of the ALIGNMENT Menu .....	43(E)
Setting Lists of the ALIGNMENT Menu .....	43(E)
Selecting the Monitor to Control — ADDRESS Menu .....	45(E)
Overview .....	45(E)
Displaying the ADDRESS Menu .....	45(E)
Cancelling the Remote Control Mode .....	46(E)
Exiting the ADDRESS Menu .....	46(E)
Short-cut Function in the ADDRESS Menu .....	46(E)

Chapter 3  
Appendix

<b>Specifications</b> .....	47(E)
Available Signal Format .....	53(E)
Connection Cable Specifications for Color Temperature Probes .....	54(E)
<b>Menu Index</b> .....	56(E)
<b>Menu Configuration</b> .....	58(E)

## Precautions

**On safety**

- Operate the unit only with a power source as specified in “Specifications” section.
- The nameplate indicating operating voltage, power consumption, etc., is located at the rear.
- Should any solid object or liquid fall into the cabinet, unplug the unit and have it checked by qualified personnel before operating it any further.
- Do not drop or place heavy objects on the power cord. If the power cord is damaged, turn off the power immediately. It is dangerous to use the unit with a damaged power cord.
- Unplug the unit from the wall outlet if it is not to be used for several days or more.
- Disconnect the power cord from the AC outlet by grasping the plug, not by pulling the cord.
- The socket-outlet shall be installed near the equipment and shall be easily accessible.
- Use the supplied AC adaptor for the BVM-D9H1U/D9H1E/D9H1A/D9H5U/D9H5E/D9H5A models only. It is dangerous to use the AC adaptor for models other than these.

**On installation**

- Allow adequate air circulation to prevent internal heat build-up.  
Do not place the unit on surfaces (rugs, blankets, etc.) or near materials (curtains, draperies) that may block the ventilation holes.
- Do not install the unit in a location near heat sources such as radiators or air ducts, or in a place subject to direct sunlight, excessive dust, mechanical vibration or shock.

**On mounting the rack**

When the monitor is mounted on the rack, the proximity of other equipment or a decrease in air circulation may cause heat to build up inside the monitor. Therefore, when mounting the monitor on the rack, ensure there is an adequate opening for ventilation or install a fan. The following operating conditions are needed:

Temperature: 0°C to 35°C (32°F to 95°F),

Optimum temperature: 20°C to 30°C (68°F to 86°F)

**On the battery (BVM-D9H1U/D9H1E/D9H1A/D9H5U/D9H5E/D9H5A only)**

The MAIN POWER switch is not supplied with the above models. Therefore, when the power is turned off with a battery installed, the monitor is set to standby mode and a small amount of power is consumed. When the monitor is not used for a long period, remove the battery.

**On cleaning**

To keep the unit looking brand-new, periodically clean it with a mild detergent solution. Never use strong solvents such as thinner or benzene, or abrasive cleansers since they will damage the cabinet. As a safety precaution, unplug the unit before cleaning it.

**On repacking**

Do not throw away the carton and packing materials. They make an ideal container which to transport the unit.

If you have any questions about this unit, contact your authorized Sony dealer.

**On magnetism**

- Do not place the unit near any objects or pieces of equipment which generate magnetism, such as magnets, speakers, electric clocks, toys using magnets, health appliances, etc. Magnetism will cause picture bounce, oscillations or picture discoloration.
- Also, the picture may become fuzzy or the colors may not reproduce correctly due to earth magnetism. This depends on direction that the unit is installed. This is not equipment failure. In such a case, simply degauss the unit.

**On the CRT**

- Dust accumulates on the CRT easily. Clean the CRT when necessary with a soft cloth.  
The surface of the CRT is easily scratched; therefore, do not rub or touch the surface of the CRT unnecessarily since this may result in a scratched picture tube.
- If you touch the surface of the CRT, you may feel a weak electrical shock. This is simply static electricity that is generated on the surface of the CRT. It will not affect the human body.

**On using as the monitor for 4:3 signals**

The 16:9 mask is installed at the factory. When the display is set to the 4:3 aspect ratio, the upper and lower portions of the display are masked and you cannot view the upper and lower portions of the picture. Therefore, when you want to display the picture in 4:3 aspect ratio, install the supplied 4:3 mask.

## Overview

The BVM-D9H1U/D9H1E/D9H1A/D9H5U/D9H5E/D9H5A are 9-inch Trinitron®<sup>1)</sup> Color Monitors. The BVM-D14H1U/D14H1E/D14H1A/D14H5U/D14H5E/D14H5A are 14-inch<sup>2)</sup> Trinitron® Color Monitors.

### Features

#### Multiformat

The monitor supports the principal format (480I/480P/720P/1080I) for the digital broadcasts, NTSC and PAL color systems, and a wide variety of signals<sup>3)</sup> whose horizontal frequency is between 15 kHz and 45 kHz.

#### High resolution picture tube

The HR Trinitron picture tube produces a clear, high resolution image.

Model	Aperture grille pitch	Resolution at the center of the picture
BVM-D9H1U/ D9H1E/D9H1A/ D9H5U/D9H5E/ D9H5A	0.25 mm	450 TV lines (4:3) 340 TV lines (16:9)
BVM-D14H1U/ D14H1E/D14H1A/ D14H5U/D14H5E/ D14H5A	0.25 mm	800 TV lines (4:3) 600 TV lines (16:9)

#### Separate control unit (BVM-D9H1U/D9H1E/D9H1A/D14H1U/D14H1E/D14H1A)

Using a separate control unit reduces the space needed for the equipment.

The monitor is controlled by a separate control unit, such as an optional BKM-10R/11R Monitor Control Unit or by daisy chain connections.

#### Controlling monitor groups

Up to 32 monitors can be controlled from one control unit by the RS-485 serial remote connections. You can control individual monitors or monitor groups simply by entering monitor address or group numbers. You can also execute the same operation on all connected monitors, or put all connected monitors into the same setup and adjustment state.

#### Auto chroma phase and white balance functions

The chroma and phase of the decoder are automatically adjusted with the auto chroma phase function and the color temperature is automatically adjusted with the auto white balance function by using the BKM-14L Auto Setup Probe, etc.

#### 4:3 area marker

It is possible to check the 4:3 aspect area in the 16:9 picture by displaying the 4:3 marker.

#### Expandable input capability

You can obtain HD SDI signals, D1 SDI signals, NTSC/PAL signals or YPbPr/RGB signals by installing the optional input adaptors at the rear of the monitor. The input connector configuration can be easily modified and up to three adaptors can be installed. The BKM-129X Analog Component Input Adaptor is installed at SLOT 1 at the factory.

#### Stable color temperature

The beam current feedback circuit maintains a constant color temperature over long periods of time.

#### Blue-only mode convenient for monitoring noise

All three CRT cathodes can be driven with a blue signal, producing a monochrome display. This mode is convenient for chroma and phase adjustment, and for monitoring VTR noise.

#### Other features

- The monitor's various functions and operating conditions can be set with on-screen menus.
- Has both RS-485 serial remote and relay contact parallel remote control connectors.
- H delay and V delay functions for simultaneous checking of the horizontal and vertical synchronization signals. VITS (Vertical Interval Test Signal) checking is also possible.
- Auto and manual degaussing.
- The monitor may be mounted in an EIA-standard 19-inch rack, using an optional MB-520 (for 9-inch monitor) or BKM-30E14/31E14 (for 14-inch monitor) Rack Mount Kit.
- The appearance of the monitor can be changed to 16:9 or 4:3 display by the replacement of a mask.
- Operable by using a Sony lithium ion battery (BP-L60/L90A) or DC 12 V external power source. (BVM-D9H1U/D9H1E/D9H1A/D9H5U/D9H5E/D9H5A only)
- Built-in audio reproduce circuit and speaker. (BVM-D9H5U/D9H5E/D9H5A only)

### Options

#### For external control

##### BKM-10R Monitor Control Unit

A controller for the BVM-D9H/D14H series video monitors, allowing you to control multiple monitors from one control unit.

##### BKM-11R Monitor Control Unit

A controller for the BVM-D9H/D14H and other BVM/HDM series video monitors, allowing you to control multiple monitors from one control unit.

##### BKM-14L Auto Setup Probe

A probe, allowing the automatic adjustment of this monitor's color temperature.

#### For installation

##### MB-520 Mounting Bracket

Mounting bracket to mount one or two BVM-D9H1U/D9H1E/D9H1A/D9H5U/D9H5E/D9H5A in a 19-inch EIA standard rack.

##### MB-519 Mounting Panel

Panel for the BVM-D9H1U/D9H1E/D9H1A to fill up the space created when mounting a video monitor to a rack with the MB-520 mounting bracket.

##### MB-509 Mounting Panel

Panel for the BVM-D9H5U/D9H5E/D9H5A to fill up the space created when mounting a video monitor to a rack with the MB-520 mounting bracket.

##### BKM-30E14 Rack Mount Kit

Rack mount kit for mounting the BVM-D14H5U/D14H5E/D14H5A in an EIA standard 19-inch rack.

##### BKM-31E14 Rack Mount Kit

Rack mount kit for mounting the BVM-D14H1U/D14H1E/D14H1A in an EIA standard 19-inch rack.

#### Others

##### VF-508 Monitor ENG Kit

Kit that includes a light intercepting hood which is mounted on the front of a monitor, and a connector protector which is mounted on the rear.

#### Input adaptors

The input connector panel is configured by sliding the optional input adaptor into the input option slot at the rear of the monitor. Up to three adaptors can be installed to the monitor.

The input signal type for each connector of the adaptor is set with the INPUT CONFIG menu, in accordance with the configuration of the connector panel.

#### Note

When installing the adaptor, be sure to perform the necessary input signal setup with the INPUT CONFIG menu. If the setup is not performed, the adaptors may not function correctly.

For information about the INPUT CONFIG menu, see "[C] Setting the Input Configuration — INPUT CONFIG Menu" on page 35(E).

1) Trinitron® is a registered trademark of Sony Corporation.  
 2) 9-inch and 14-inch refer to the CRT size of the monitor.  
 For effective picture size, see "Specifications" on page 47(E).  
 3) For details on the signal format, see "Available Signal Format" on page 53(E).  
 4 (E)

## Overview

**BKM-120D SDI 4:2:2 Input Adaptor**  
Includes a decoder for serial digital component signals. D1 SDI input/output connectors for two serial digital channels and active loop-through output connectors.

**BKM-127W NTSC/PAL Input Adaptor**  
Includes decoders for analog composite NTSC and PAL signals. Input/output connectors for two analog channels and one YC channel.

**BKM-129X Analog Component Input Adaptor**  
Includes input/output connectors for one analog channel and EXT SYNC input/output connectors.

The BKM-129X is mounted to the monitor at the factory.

**BKM-142HD HD SDI Input Adaptor**  
Includes a decoder for HD serial digital signals and input/output connectors for two serial digital signal channels and monitor output connector.

**Notes**

- The BKM-142HD uses two input option slots.
- The signal from MONITOR OUT connector does not satisfy the ON-LINE signal specifications.

## Location and Function of Parts

### BVM-D9H1U/D9H1E/D9H1A/D9H5U/D9H5E/D9H5A Front Panel

For the BVM-D14H1U/D14H1E/D14H1A/D14H5U/D14H5E/D14H5A, see pages 16(E) to 20(E).

#### BVM-D9H1U/D9H1E/D9H1A

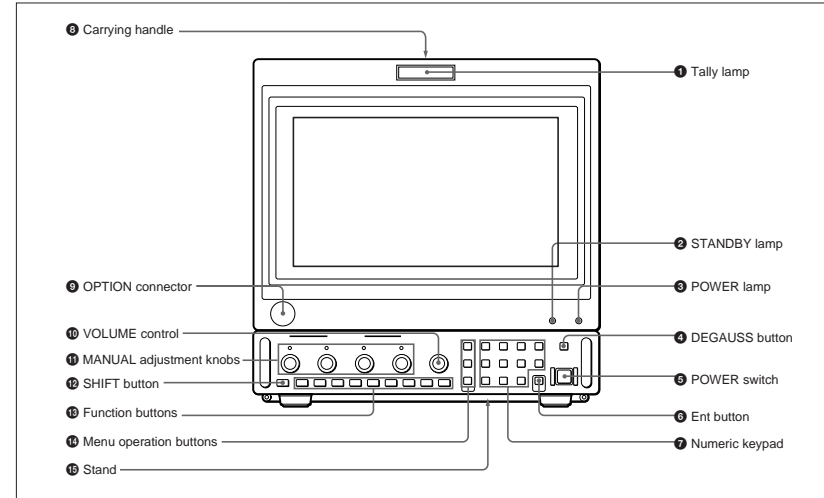

#### BVM-D9H5U/D9H5E/D9H5A

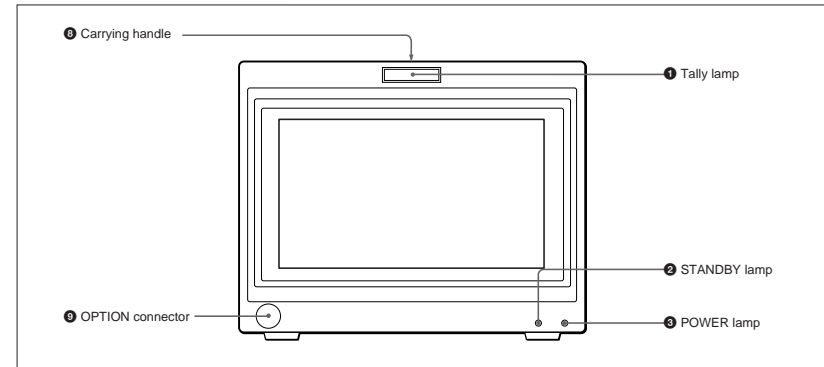

## Location and Function of Parts

This manual explains the location and function of parts and controls of the BVM-D9H5U/D9H5E/D9H5A. The explanation also applies to the optional BKM-10R/11R Monitor Control Unit.

### 1 Tally lamp

With factory settings, the tally lamp lights as follows when the pins of the PARALLEL REMOTE [1] connector on the rear panel are shorted:

- in red, when pins No.3 and No.9 are shorted.
- in green, when pins No.4 and No.9 are shorted.
- in amber, when pins No.3, No.4 and No.9 are shorted.

The tally lamp lights as follows when the pins of the PARALLEL REMOTE [2] connector on the rear panel are shorted:

- in red, when pins No.3 and No.5 are shorted.
- in green, when pins No.4 and No.5 are shorted.
- in amber, when pins No.3, No.4 and No.5 are shorted.

By changing the setting in the REMOTE menu, different pins on the remote connector can be used to control the tally lamp.

For information about the REMOTE menu, see “[D] Assigning the Remote Control Functions — REMOTE Menu” on page 37(E).

### 2 STANDBY lamp

Lights when the monitor is in standby mode. The monitor will be in standby mode under the following conditions:

- The AC adaptor or battery is attached to the monitor when the STANDBY MODE menu of the SYSTEM CONFIG menu is set to ON.
- The monitor is changed from operation mode to standby mode by external control.

For information about the SYSTEM CONFIG menu, see “[E] Setting the Power-Up Conditions and Data about the Screen Display — SYSTEM CONFIG Menu” on page 39(E).

### 3 POWER lamp

Lights when the monitor is put into operation mode from standby mode (see STANDBY lamp 2) by pressing the POWER switch 5.

### Note

When the STANDBY lamp 2 is blinking, the monitor cannot be put into operation mode (internal data initialization is taking place). Wait until the STANDBY lamp 2 is steadily lit.

### 4 DEGAUSS button

Press to degauss the CRT (every time the monitor is turned on, the CRT is degaussed automatically). To degauss again, wait for more than five minutes.

### 5 POWER switch

Press to turn on/off the monitor. By setting with the ADDRESS menu, it is possible to turn on/off the power of the specified monitors only, or of all monitors at the same time.

For information about the ADDRESS menu, see “Selecting the Monitor to Control — ADDRESS Menu” on page 45(E).

### 6 Ent button

Use to confirm the items, values and characters entered.

### 7 Numeric keypad

Use to designate the channel number for the input signal to be monitored, or to enter the setting values with the menus.

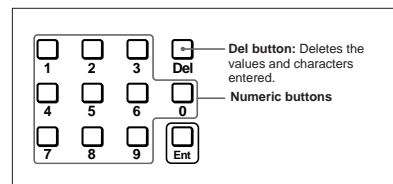

### 8 Carrying handle

Pull out to use for carrying the monitor.

### 9 OPTION connector

Used to connect the BKM-11R Monitor Control Unit or Auto Setup Probe (BKM-14L, etc.)

### 10 VOLUME control

Adjusts the volume of the audio signals from the equipment connected to the AUDIO IN jacks at the rear of the monitor.

### 11 MANUAL adjustment knobs

Each press of one of these knobs turns the knob's green LED on or off. When the corresponding knob is on (lit), it is possible to manually adjust the contrast, brightness, chroma and phase by turning the corresponding knobs. The PHASE knob is also used to select the items or enter the setting values with the menus. It is possible to set the preset value for each adjusting item with the CONTROL PRESET ADJ menu.

For information about the CONTROL PRESET ADJ menu, see “[A] Preset Adjustment of the Picture Level Control Knobs — CONTROL PRESET ADJ menu” on page 31(E).

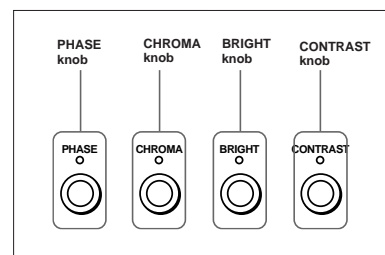

### Note

The PHASE and CHROMA knobs may not be adjusted due to the signals. However, these knobs are used for selecting the items or entering the setting values with the menus.

### 12 SHIFT button

Press to select one of the two functions designated to the function buttons 13.

Each time the SHIFT button is pressed, the LED turns on (SHIFT ON: lits in amber) and off (SHIFT OFF.)

**SHIFT OFF:** The functions indicated above the function buttons can be used (the LED of the function button lits in green.)

**SHIFT ON:** The functions indicated below the function buttons can be used (the LED of the function button lits in amber.)

### 13 Function buttons

Change the operation conditions for the monitor. Each time the button is pressed, the LED turns on and turns off, and the operation conditions are changed. Each button has two functions. Select one of the two functions by pressing the SHIFT button 12. When the SHIFT button is set to ON, the LED lights in amber, and when the SHIFT button is set to OFF, the LED of each button lights in green.

For the functions of the function buttons in case of SHIFT OFF and SHIFT ON, see pages 10(E) and 11(E).

### 14 Menu operation buttons

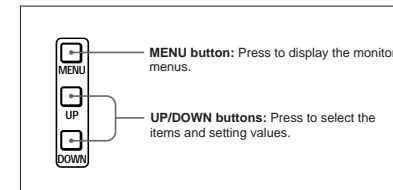

For more information about menu operation, see “Basic Menu Operations” on page 25(E).

### 15 Stand

Pull out to use.

## Using the Carrying Handle and Stand

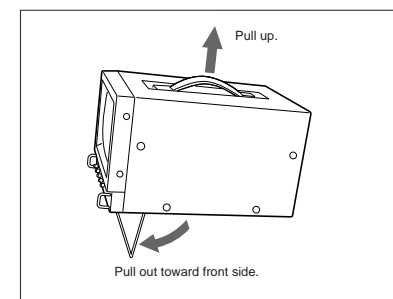

## Location and Function of Parts

### Function buttons in SHIFT OFF mode (LEDs of function buttons in green)

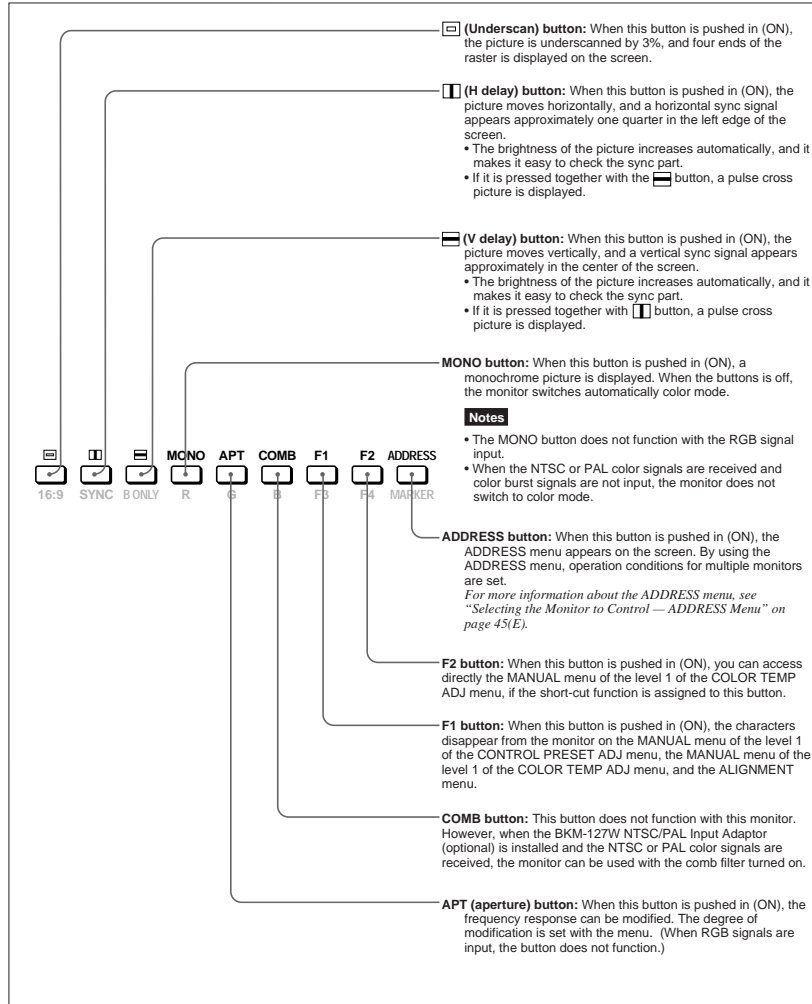

10 (E)

### Function buttons in SHIFT ON mode (LEDs of function buttons in amber)

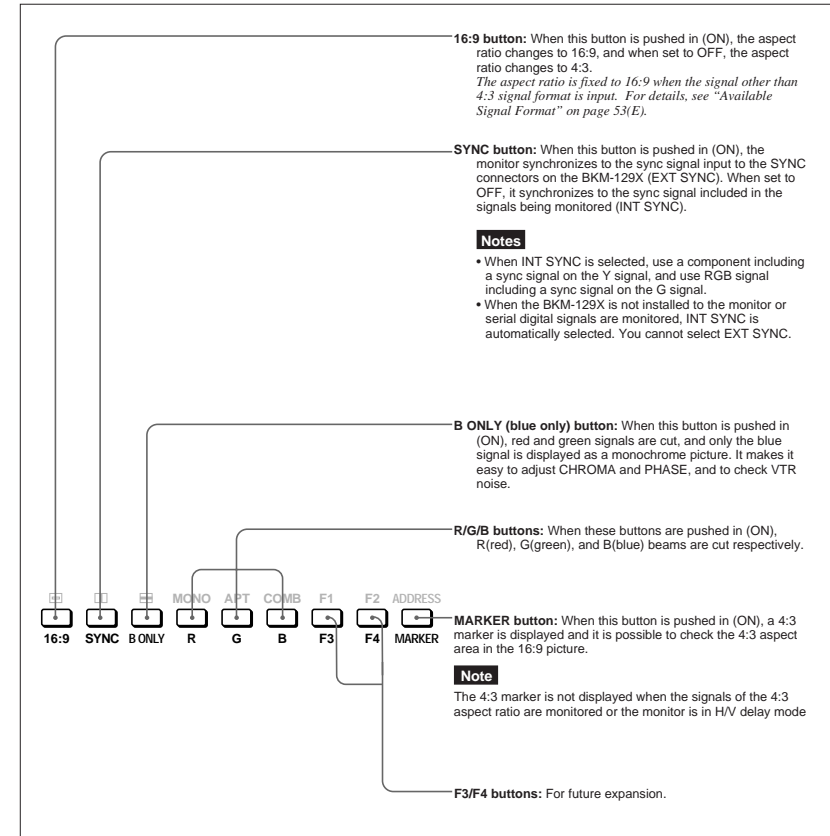

11 (E)

## Location and Function of Parts

### BVM-D9H1U/D9H1E/D9H1A/D9H5U/D9H5E/D9H5A Rear Panel

For the BVM-D14H1U/D14H1E/D14H1A/D14H5U/D14H5E/D14H5A, see pages 21(E) to 23(E).

#### BVM-D9H5U/D9H5E/D9H5A

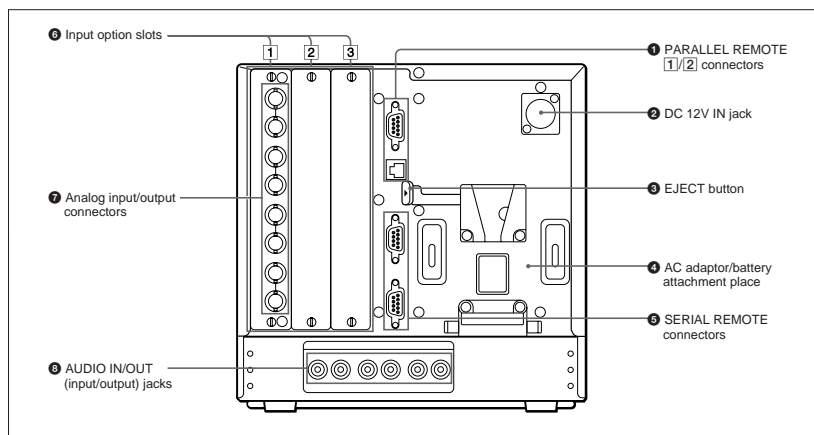

#### BVM-D9H1U/D9H1E/D9H1A

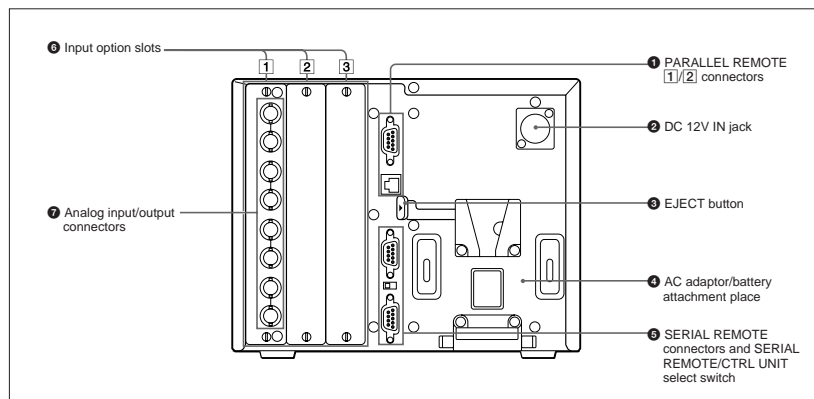

- 1 PARALLEL REMOTE 1/2 connectors**  
**(1): female, D-sub 9-pin, (2): modular connector**  
 Form a parallel switch and controls the monitor externally. The pin assignment and factory setting function assigned to each pin are given below.

**1: D-sub 9-pin**

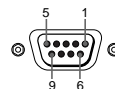

Pin number	Functions
1	Set input signal channel 1 (numeric keypad function)
2	Set input signal channel 2 (numeric keypad function)
3	Set red tally lamp on or off
4	Set green tally lamp on or off
5	Select sync signal (SYNC button function)
6	Set underscan on or off
7	Set a 16:9 aspect ratio on or off
8	Set the 4:3 area marker display on or off
9	GND

**2: modular connector**



Pin number	Functions
1	Set input signal channel 1 (numeric keypad function)
2	Set input signal channel 2 (numeric keypad function)
3	Set red tally lamp on or off
4	Set green tally lamp on or off
5	GND
6	Set underscan on or off

All pin function assignments can be changed with the REMOTE menu.

For information about the REMOTE menu, see “ [D] Assigning the Remote Control Functions — REMOTE Menu ” on page 37(E).

To switch each function between on and off or between enable and disable, change pin connections in the following way.

**ON or enabled:** Short each pin and pin 9 together for **D-sub 9-pin**.

Short each pin and pin 5 together for **modular connector**.

**OFF or disabled:** Leave each pin open.

- 2 DC 12V IN jack (XLR-type, 4-pin)**  
 Connects the DC 12V external power source to use the monitor.

- 3 EJECT button**  
 While sliding this button, remove the AC adaptor or battery.

- 4 AC adaptor/battery attachment place**  
 Attach the AC adaptor or battery.

- 5 SERIAL REMOTE connectors (female, D-sub 9-pin), and SERIAL REMOTE/CTRL UNIT select switch (BVM-D9H1U/D9H1E/D9H1A only)**  
 These are RS-485 serial interface connectors, used for connecting two or more BVM-xxE/F/G, BVM-xxD and HDM-xxE series monitors. The IN and OUT connectors form a loop-through connection.  
 BVM-D9H1U/D9H1E/D9H1A only: The SERIAL REMOTE/CTRL UNIT select switch is set to SERIAL REMOTE at the factory.

#### For connecting the monitor (used for daisy chain connections)

Connect two monitors using a cable with D-sub 9-pin plugs such as an RCC-5G (not supplied) as follows:

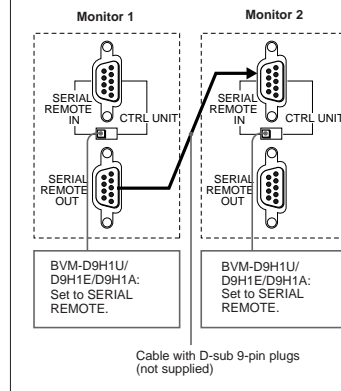

(continued)

## Location and Function of Parts

### For connecting the BKM-10R Monitor Control Unit

Connect the monitor and control unit using a cable with D-sub 9-pin plugs such as an RCC-5G (not supplied) as follows:

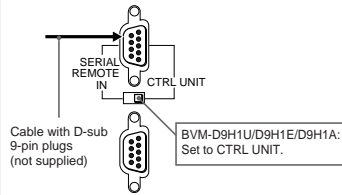

### 6 Input option slots (three slots)

The monitor may be fitted with optional input adaptors up to three.

The BKM-129X is installed to the monitor at the factory.

#### Notes

- The BKM-142HD uses two input option slots.
- Each adaptor can also be installed into SLOT 1. Install any adaptor to SLOT 1.

### 7 Analog input/output connectors (BKM-129X)

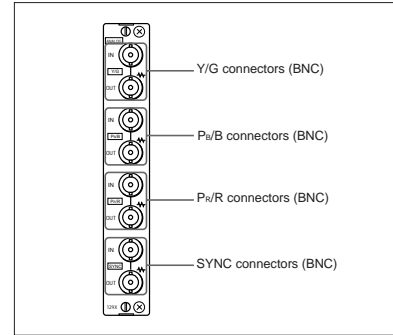

RGB signals or component signals (Y/P<sub>B</sub>/P<sub>R</sub>) can be fed in the IN connectors. The type of signal applied to each connector is set with the INPUT CONFIG menu. The OUT connectors are used for loop-through output of the input signal.

For information about the INPUT CONFIG menu, see “[Setting the Input Configuration — INPUT CONFIG Menu](#)” on page 35(E).

### 8 AUDIO IN/OUT (input/output) jacks (BVM-D9H5U/D9H5E/D9H5A only)

Connects to the audio output jacks of the VCR or microphone amplifier. The monitor is equipped with three input and output jacks. You can obtain the loop-through output from the OUT jacks.

### Attaching the AC adaptor or battery

#### Attaching

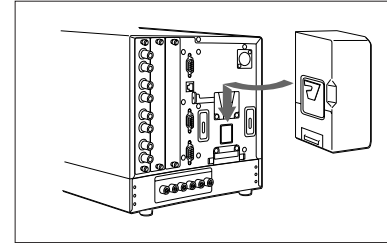

#### Removing the AC adaptor or battery

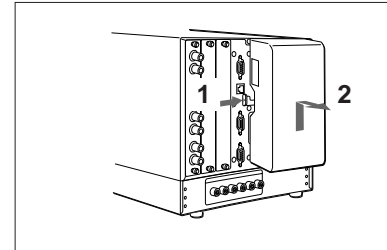

#### Note

Use the supplied AC adaptor for the BVM-D9H1U/D9H1E/D9H1A/D9H5U/D9H5E/D9H5A models only. It is dangerous to use the AC adaptor for models other than these.

### Connecting the AC power cord

Attach the AC adaptor to the monitor, and then connect the supplied AC power cord.

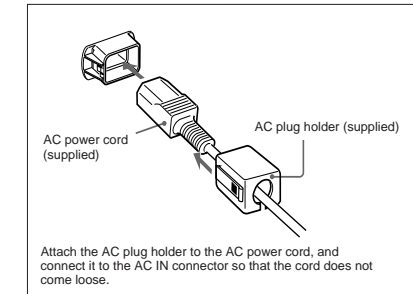

Attach the AC plug holder to the AC power cord, and connect it to the AC IN connector so that the cord does not come loose.



## Location and Function of Parts

### BVM-D14H1U/D14H1E/D14H1A/D14H5U/D14H5E/D14H5A Front Panel

#### BVM-D14H5U/D14H5E/D14H5A

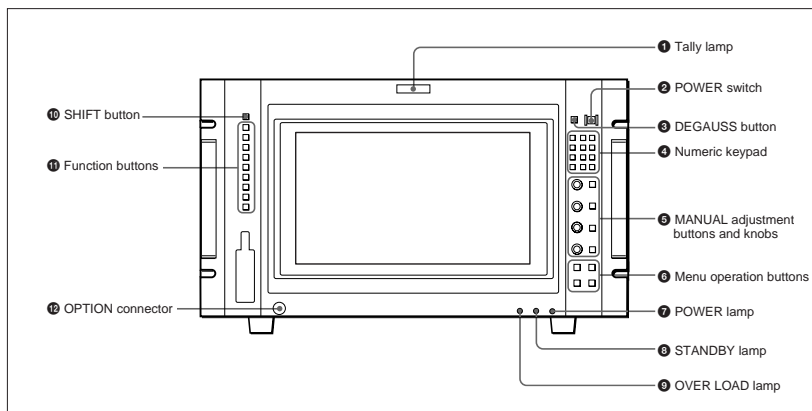

#### BVM-D14H1U/D14H1E/D14H1A

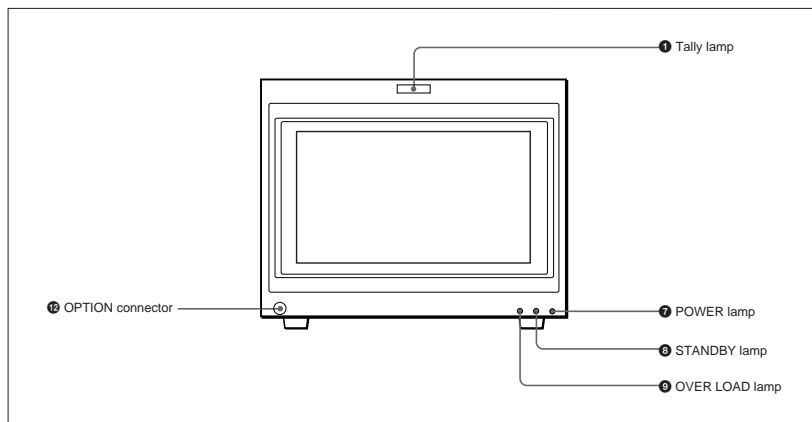

This manual explains the location and function of parts and controls of the BVM-D14H5U/D14H5E/D14H5A. The explanation also applies to the optional BKM-10R/11R Monitor Control Unit.

#### 1 Tally lamp

With factory settings, the tally lamp lights as follows when the pins of the PARALLEL REMOTE [1] connector on the rear panel are shorted:

- in red, when pins No.3 and No.9 are shorted.
- in green, when pins No.4 and No.9 are shorted.
- in amber, when pins No.3, No.4 and No.9 are shorted.

The tally lamp lights as follows when the pins of the PARALLEL REMOTE [2] connector on the rear panel are shorted:

- in red, when pins No.3 and No.5 are shorted.
- in green, when pins No.4 and No.5 are shorted.
- in amber, when pins No.3, No.4 and No.5 are shorted.

By changing the setting in the REMOTE menu, different pins on the remote connector can be used to control the tally lamp.

For information about the REMOTE menu, see "[D] Assigning the Remote Control Functions — REMOTE Menu" on page 37(E).

#### 2 POWER switch

Press to turn on/off the monitor. By setting with the ADDRESS menu, it is possible to turn on/off the power of the specified monitors only, or of all monitors at the same time.

For information about the ADDRESS menu, see "Selecting the Monitor to Control — ADDRESS Menu" on page 45(E).

#### 3 DEGAUSS button

Press to degauss the CRT (every time the monitor is turned on, the CRT is degaussed automatically). To degauss again, wait for more than five minutes.

#### 4 Numeric keypad

Use to designate the channel number for the input signal to be monitored, or to enter the setting values with the menus.

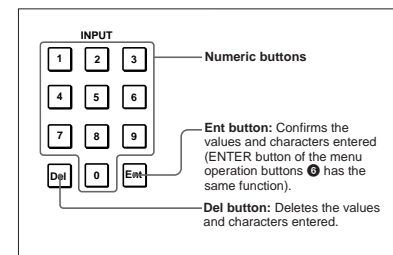

#### 5 MANUAL adjustment buttons and knobs

Each press of one of these buttons turns the button's green LED on or off. When the corresponding button is on (lit), it is possible to manually adjust the contrast, brightness, chroma and phase by turning the corresponding knobs. The PHASE knob is also used to enter the setting values with the menus. It is possible to set the preset value for each adjusting item with the CONTROL PRESET ADJ menu.

For information about the CONTROL PRESET ADJ menu, see "[A] Preset Adjustment of the Picture Level Control Knobs — CONTROL PRESET ADJ menu" on page 31(E).

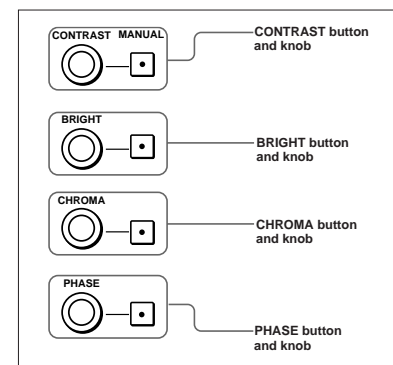

#### Note

The PHASE and CHROMA knobs may not be adjusted due to the signals. However, these knobs are used for selecting the items or entering the setting values with the menus.

(continued)

## Location and Function of Parts

### 6 Menu operation buttons

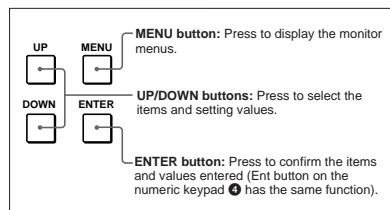

For more information about menu operation, see "Basic Menu Operations" on page 25(E).

### 7 POWER lamp

Lights when the monitor is put into operation mode from standby mode (see STANDBY lamp 8) by pressing the POWER switch 2.

#### Note

When the STANDBY lamp 8 is blinking, the monitor cannot be put into operation mode (internal data initialization is taking place). Wait until the STANDBY lamp 8 is steadily lit.

### 8 STANDBY lamp

Lights when the monitor is in standby mode. The monitor will be in standby mode under the following conditions:

- The MAIN POWER switch (on the rear panel) is turned on when the STANDBY MODE menu of the SYSTEM CONFIG menu is set to ON (the STANDBY lamp will blink for a few moments after the switch is turned on, then will light).
- The monitor is changed from operation mode to standby mode by external control.

For information about the SYSTEM CONFIG menu, see "[E] Setting the Power-Up Conditions and Data about the Screen Display — SYSTEM CONFIG Menu" on page 39(E).

### 9 OVER LOAD lamp

Lights when some malfunction has occurred. When the OVER LOAD lamp is lit, consult your nearest Sony service facilities.

### 10 SHIFT button

Press to select one of the two functions designated to the function buttons 11.

Each time the SHIFT button is pressed, the LED turns on (SHIFT ON: lits in amber) and off (SHIFT OFF.)

**SHIFT OFF:** The functions indicated above the function buttons can be used (the LED of the function button lits in green.)

**SHIFT ON:** The functions indicated below the function buttons can be used (the LED of the function button lits in amber.)

### 11 Function buttons

Change the operation conditions for the monitor. Each time the button is pressed, the LED turns on and turns off, and the operation conditions are changed. Each button has two functions. Select one of the two functions by pressing the SHIFT button 10. When the SHIFT button is set to ON, the LED lights in amber, and when the SHIFT button is set to OFF, the LED of each button lights in green.

For the functions of the function buttons in case of SHIFT OFF and SHIFT ON, see pages 19(E) and 20(E).

### 12 OPTION connector

Used to connect the BKM-11R Monitor Control Unit or Auto Setup Probe (BKM-14L, etc.)

### Function buttons in SHIFT OFF mode (LEDs of function buttons in green)

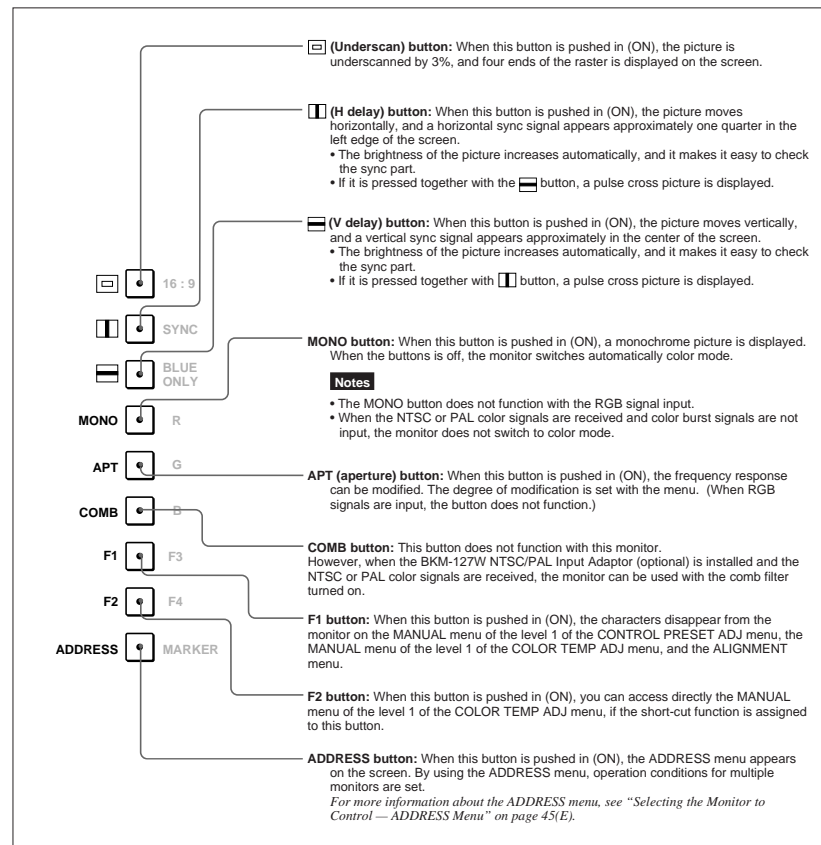

## Location and Function of Parts

### Function buttons in SHIFT ON mode (LEDs of function buttons in amber)

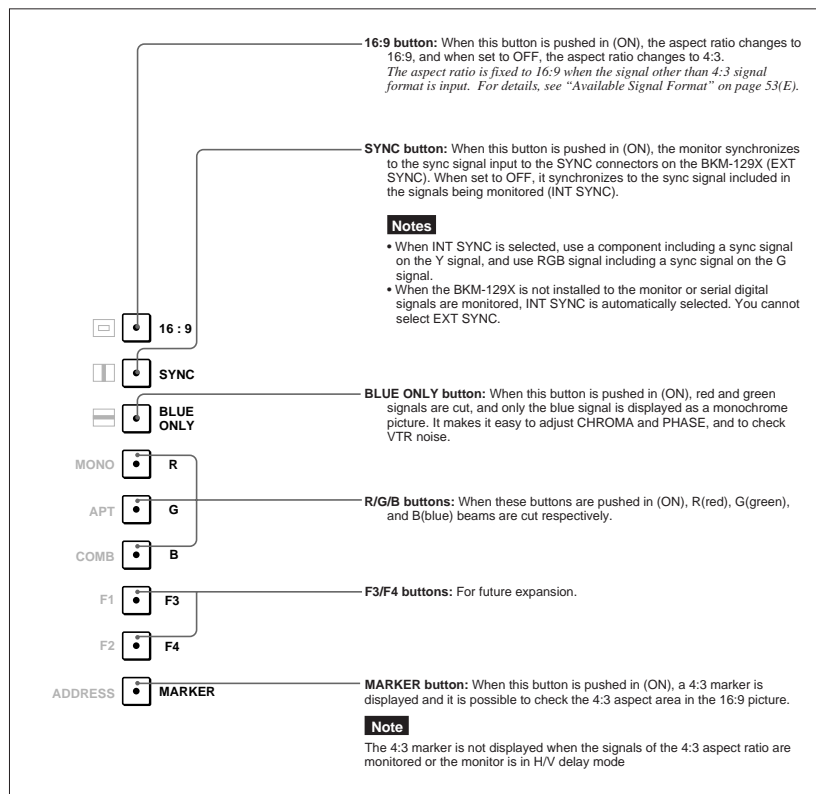

## BVM-D14H1U/D14H1E/D14H1A/D14H5U/D14H5E/D14H5A Rear Panel

### BVM-D14H5U/D14H5E/D14H5A

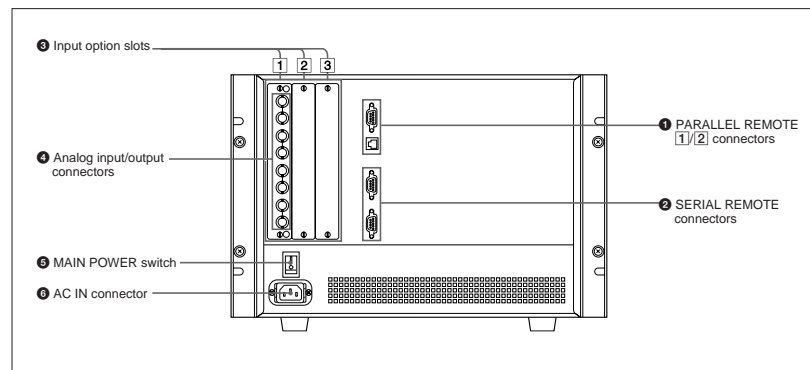

### BVM-D14H1U/D14H1E/D14H1A

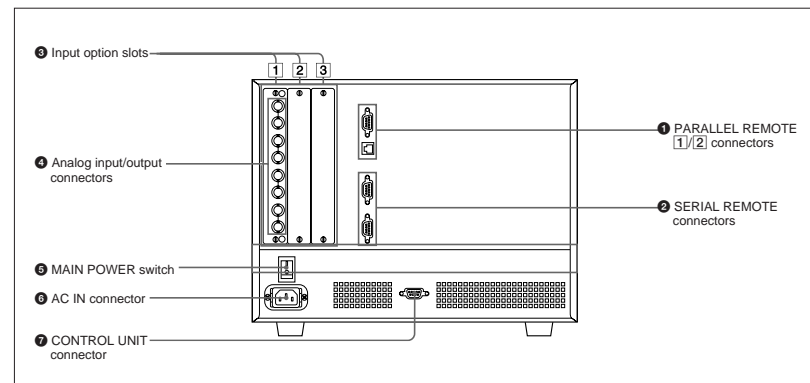

(continued)

## Location and Function of Parts

### 1 PARALLEL REMOTE [1]/[2] connectors (1: female, D-sub 9-pin, 2: modular connector)

Form a parallel switch and controls the monitor externally. The pin assignment and factory setting function assigned to each pin are given below.

#### 1: D-sub 9-pin

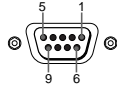

Pin number	Functions
1	Set input signal channel 1 (numeric keypad function)
2	Set input signal channel 2 (numeric keypad function)
3	Set red tally lamp on or off
4	Set green tally lamp on or off
5	Select sync signal (SYNC button function)
6	Set underscan on or off
7	Set a 16:9 aspect ratio on or off
8	Set the 4:3 area marker display on or off
9	GND

#### 2: modular connector



Pin number	Functions
1	Set input signal channel 1 (numeric keypad function)
2	Set input signal channel 2 (numeric keypad function)
3	Set red tally lamp on or off
4	Set green tally lamp on or off
5	GND
6	Set underscan on or off

All pin function assignments can be changed with the REMOTE menu.

For information about the REMOTE menu, see “ [D] Assigning the Remote Control Functions — REMOTE Menu” on page 37(E).

To switch each function between on and off or between enable and disable, change pin connections in the following way.

**ON or enabled:** Short each pin and pin 9 together for **D-sub 9-pin**.  
Short each pin and pin 5 together for **modular connector**.

**OFF or disabled:** Leave each pin open.

### 2 SERIAL REMOTE connectors (female, D-sub 9-pin)

These are RS-485 serial interface connectors, used for connecting two or more BVM-xxE/F/G, BVM-xxD and HDM-xxE series monitors.

The IN and OUT connectors form a loop-through connection.

Connect two monitors using a cable with D-sub 9-pin plugs such as an RCC-5G (not supplied) as shown in the figure on the next page.

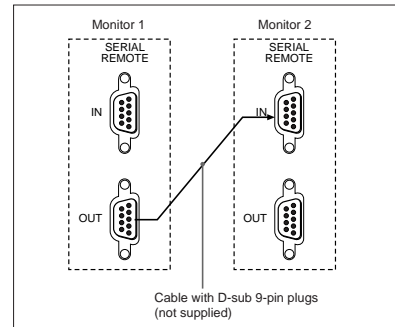

### 3 Input option slots (three slots)

The monitor may be fitted with optional input adaptors up to three.

The BKM-129X is installed to the monitor at the factory.

#### Notes

- The BKM-142HD uses two input option slots.
- Each adaptor can also be installed into SLOT 1. Install any adaptor to SLOT 1.

### 4 Analog input/output connectors (BKM-129X)

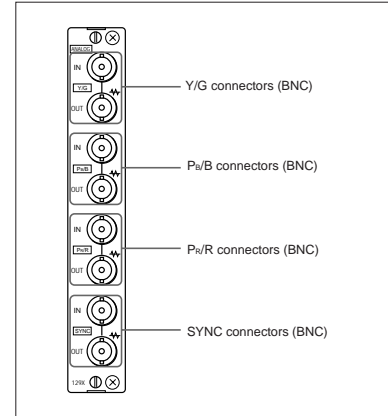

RGB signals or component signals (Y/P<sub>B</sub>/P<sub>R</sub>) can be fed in the IN connectors. The type of signal applied to each connector is set with the INPUT CONFIG menu. The OUT connectors are used for loop-through output of the input signal.

For information about the INPUT CONFIG menu, see “ [C] Setting the Input Configuration — INPUT CONFIG Menu” on page 35(E).

### 5 MAIN POWER switch

When turned on, the monitor enters operation mode. By setting in the SYSTEM CONFIG menu, the monitor can also be set to enter standby mode when the MAIN POWER switch is turned on.

For information about the SYSTEM CONFIG menu, see “ [E] Setting the Power-Up Conditions and Data about the Screen Display — SYSTEM CONFIG Menu” on page 39(E).

### 6 AC IN connector (3-pin)

Connects the monitor to an AC power source, via the supplied AC power cord.

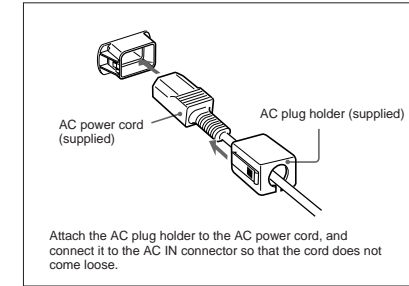

### 7 CONTROL UNIT connector (female, D-sub 9-pin) (BVM-D14H1U/D14H1E/D14H1A only)

Connects a monitor control unit such as the BKM-10R using a cable with D-sub 9-pin plugs such as an RCC-5G (not supplied).

## Installation of the 4:3 Mask

When the aspect ratio is switched from 16:9 to 4:3, replace the 16:9 mask with the supplied 4:3 mask.

### BVM-D9H1U/D9H1E/D9H1A/ D9H5U/D9H5E/D9H5A

#### Installing the 4:3 mask

- 1 Remove four screws from both sides of the monitor and then remove the 16:9 mask.

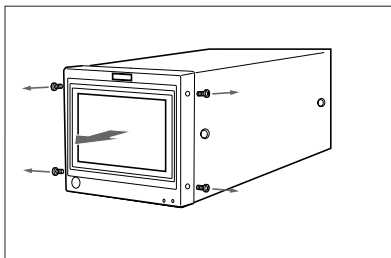

- 2 Install the 4:3 mask (supplied) and fix both sides with four screws.

#### Replacing the 16:9 mask

Remove the 4:3 mask and replace the 16:9 mask using the same procedures as those for installing the 4:3 mask.

### BVM-D14H1U/D14H1E/D14H1A/ D14H5U/D14H5E/D14H5A

#### Installing the 4:3 mask

- 1 Remove the 16:9 mask.

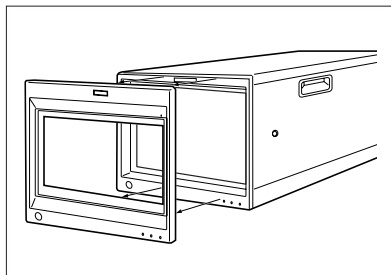

- 2 Install the 4:3 mask (supplied).
  - 1 Attach the lower portion of the mask.
  - 2 Attach the upper portion of the mask by pressing it until the click.

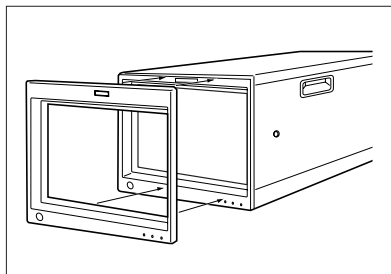

#### Replacing the 16:9 mask

Remove the 4:3 mask and replace the 16:9 mask using the same procedures as those for installing the 4:3 mask.

## Basic Menu Operations

### Menu Operation Buttons

The menus are operated using the menu operation buttons on the front panel of the monitor or BKM-10R/11R Monitor Control Unit.

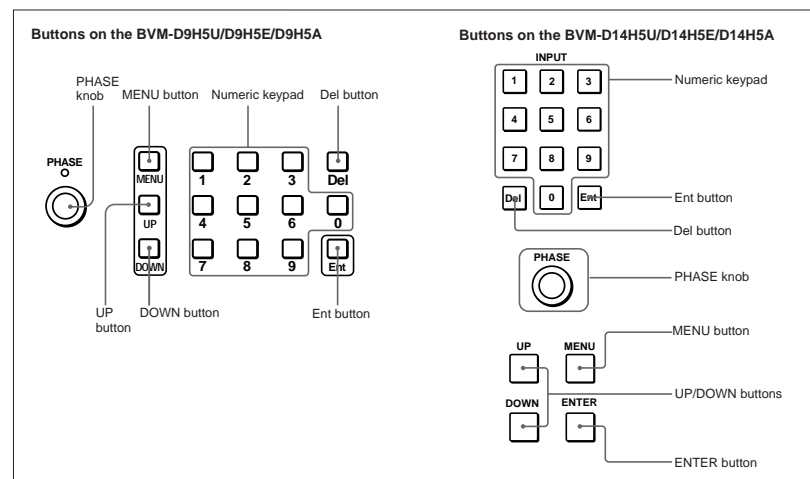

The functions of the menu operation buttons are described below.

Button	Function
UP button	Moves the cursor upward. In setting mode, increases the setting and adjustment values.
DOWN button	Moves the cursor downward. In setting mode, decreases the setting and adjustment values.
MENU button	Displays the Menus. Goes back to the menu of the upper level (on the Main Menu, goes back to the normal picture).
ENTER button/ Ent button	Executes the items selected and settings.
PHASE knob	By turning this knob clockwise, the cursor moves upward. In setting mode, increases the setting and adjustment values (has the same function as UP button). By turning this knob counterclockwise, the cursor moves downward. In setting mode, decreases the setting and adjustment values (has the same function as DOWN button).
Numeric keypad	Enters the numerical values.
Del button	Deletes the values and characters entered.

## Basic Menu Operations

### Displaying the Menus

Press the MENU button.  
The menu list is displayed on the screen.

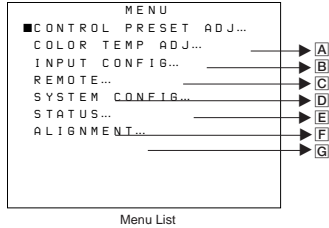

When you select one item on the main menu, the level 1 menu corresponding to the selected item on the main menu appears.

For information about the items on the main menu, see "Menu Structure" on page 30(E).

**Note**

Menu settings that cannot be changed are displayed in blue.

### About menu numbers

For purposes of explanation in this manual, each menu is preceded by menu numbers. The alphabet determines the classification of menus on the Menu List (Main Menu), and the numbers determine the level and the order. These menu numbers are not shown on the screen.

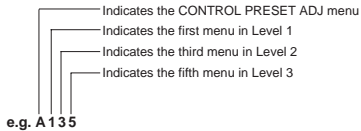

**Note**

Only the menus which require explanation are preceded by menu numbers. Thus, the menu number is counted without menus which do not require explanation.

### Menu Operation

Follow the steps described below to display the menu and perform the adjustment or setup you wish.

- 1 Press the MENU button.  
The Menu List is displayed.
- 2 Using the UP/DOWN buttons or PHASE knob, move the cursor to the desired item. (Example: select the INPUT CONFIG menu by pressing the DOWN button.)

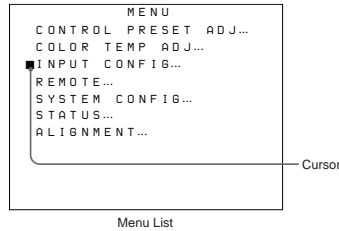

- 3 Press the ENTER button or Ent button.  
The Level 1 of the selected menu is displayed.

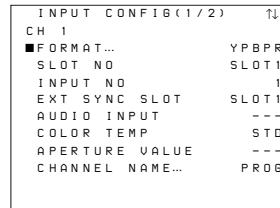

(continued)

- 4 Repeat steps 2 and 3 until the desired menu is displayed.

For more information about setting and adjustments, see below.

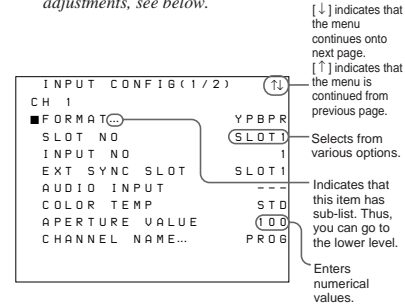

### To abort menu operation

Press the MENU button. The menu of the upper level is displayed.  
The setting or adjustment being performed is canceled, and data loading or saving is aborted.

### If "NG" or "ERROR" appears during menu operation

Press the MENU button to return to the menu in use.

### Choosing one of two or more selections

#### Selecting in setting mode

- 1 Using the UP/DOWN buttons or PHASE knob, move the cursor to the desired item and press the ENTER or Ent button.  
The selected item is displayed in yellow text and set to setting mode.

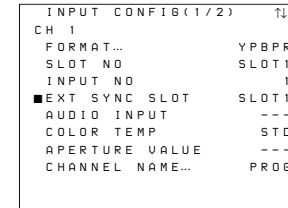

- 2 Using the UP/DOWN buttons or PHASE knob, change the setting.
- 3 Press the ENTER or Ent button.  
The setting is confirmed (The item is displayed in white text again).

#### Selecting from the setting list

- 1 Using the UP/DOWN buttons or PHASE knob, move the cursor to the desired item in the setting list.

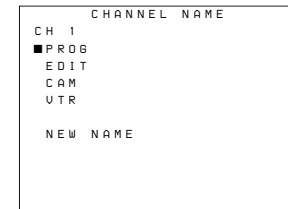

- 2 Press the ENTER or Ent button.  
The display returns to the menu of the upper level, and the selected setting is executed.

## Basic Menu Operations

### Entering a numerical value

- Using the UP/DOWN buttons or PHASE knob, move the cursor to the desired item and press the ENTER or Ent button. The selected item is displayed in yellow text and set to setting mode.

```

INPUT CONFIG(1/2)
CH 1
FORMAT... YPBPR
SLOT NO SLOT1
INPUT NO 1
EXT SYNC SLOT SLOT1
AUDIO INPUT --
COLOR TEMP STD
■ APERTURE VALUE 100
CHANNEL NAME... PROG
    
```

- Set the value in one of the following three ways:
  - Enter the value directly using the numeric keypad and press the ENTER or Ent button
  - Select the value using the UP/DOWN buttons
  - Select the value using the PHASE knob
- Press the ENTER or Ent button. The setting is confirmed (The item is displayed in white text again).

### Entering characters

- Display the setting menu and set the cursor to NEW NAME using the UP/DOWN buttons or PHASE knob.

```

CHANNEL NAME
CH 1
PROG
EDIT
CAM
UTR
■ NEW NAME
    
```

- Press the ENTER or Ent button. “?” is displayed in yellow. The “?” indicates the position where character input is possible.

```

CHANNEL NAME
CH 1
PROG
EDIT
CAM
UTR
■ NEW NAME
  ?
    
```

- Select the character you wish to enter using the UP/DOWN buttons or PHASE knob. When you press the UP button, or turn the PHASE knob clockwise, the characters and symbols appear in the order shown below.

A B .....Y Z 0 1 .....8 9 ( , ) : ; .  
- + / & (space) ?

If you press the UP/DOWN button or turn the PHASE knob counterclockwise, the characters and symbols appear in the reverse order described above.

- Press the ENTER or Ent button. The selected character is entered.

```

CHANNEL NAME
CH 1
PROG
EDIT
CAM
UTR
■ NEW NAME
  C ?
    
```

- Repeat steps 3 and 4 until all the characters are entered, then press the ENTER or Ent button. The selected characters are confirmed, and the display returns to the menu of the previous level.

#### To correct the entered character

Press the Del button on the numeric keypad. The character on the left side of the “?” (in yellow) is deleted.

## ADDRESS Menu

In addition to the menus displayed on the menu list, the ADDRESS menu is provided. This ADDRESS menu is used to select the monitor or the monitor group, so that when several monitors are connected together via serial remote ports, the control panel can select which monitor to control.

To display or exit the ADDRESS menu, press the ADDRESS button. The method of choosing menu items and changing settings is the same as with the other menus.

*For information about the ADDRESS menu, see “Selecting the Monitor to Control —ADDRESS Menu” on page 45(E).*

## Menu Structure

Menus consist of one to three levels.

Detailed information on the levels of menus is described at the top of explanation of each menu.

	Main Menu	Functions
[A]	CONTROL PRESET ADJ menu	Sets the preset values for the input signal's chroma, contrast, phase, and brightness. (page 31(E))
[B]	COLOR TEMP ADJ menu	Sets the color temperature. (page 33(E))
[C]	INPUT CONFIG menu	Sets the input channel. (page 35(E))
[D]	REMOTE menu	Sets the remote control functionality. (page 37(E))
[E]	SYSTEM CONFIG menu	Sets the power-up conditions and data about the screen display. (page 39(E))
[F]	STATUS menu	Displays the information about the monitor or options installed in the monitor. (page 42(E))
[G]	ALIGNMENT menu	Adjusts the position, size and geometry of the picture. (page 43(E))

## A Preset Adjustment of the Picture Level Control Knobs — CONTROL PRESET ADJ Menu

### Overview

The preliminary adjustments of chroma, phase, contrast and brightness are carried out with the CONTROL PRESET ADJ menu to set the preset values to the knobs for the above-mentioned adjustments.

Preset values can be set in the following two ways:

- **Adjustment with the MANUAL adjustment knobs (MANUAL menu)**
- **Automatic adjustment (AUTO menu)**  
An external color bar signal is necessary.

**Note**

After installing the optional board, carry out AUTO adjustment.

### Structure of the CONTROL PRESET ADJ Menu

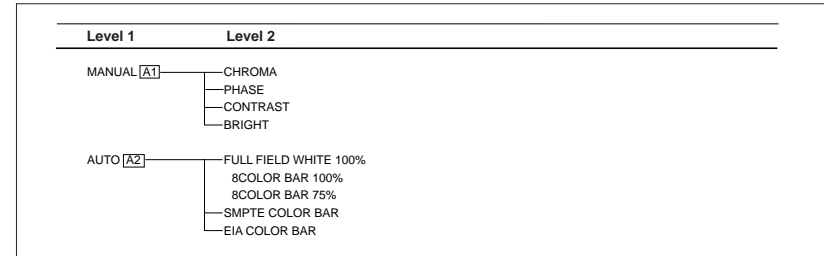

### Setting Lists in the CONTROL PRESET ADJ Menu

This section explains the setting lists displayed in the menu.

**How to read the setting lists**

- For purposes of explanation, each setting list is preceded by a menu number. These numbers are not displayed on the screen.

*For more information about the menu number, see "About menu numbers" on page 26(E).*

- The arrow mark (⇒) refers you to another setting list that appears after you make the setting, or to an operation that is carried out as a result of the setting. When there is no arrow mark, the menu does not have any sub-list.



## A Preset Adjustment of the Picture Level Control Knobs — CONTROL PRESET ADJ Menu

### A CONTROL PRESET ADJ menu

Select the setting method.

**MANUAL...** : Set with the MANUAL adjustment knobs. ⇒ [A1]

**AUTO...** : Set by automatic adjustment. ⇒ [A2]

### A1 MANUAL menu

Adjust values by turning the CHROMA, PHASE, CONTRAST, and/or BRIGHT knobs. After the adjustment, press the ENTER or Ent button to confirm the adjusted values.

The setting value is 0 to 200.

**CHROMA:** xxx

**PHASE:** xxx

**CONTRAST:** xxx

**BRIGHT:** xxx

### When you want to erase characters from the screen while adjusting manually

Press the [F1] button. The characters disappear. To display characters, press the [F1] button again.

### To reset the setting to the default

Press the corresponding MANUAL adjustment button (BVM-D14H5U/D14H5E/D14H5A) or knob (BVM-D9H5U/D9H5E/D9H5A.) The adjusted value is reset to 100 (default).

### A2 AUTO menu

You can adjust the CHROMA and PHASE levels automatically. Input the color bar signals to the board to be adjusted and select the required color bar signals. ⇒ Adjustment is carried out.

**8COLOR BAR 100%**: 100% full-field 8-color bar (white, yellow, cyan, green, magenta, red, blue, black)

**8COLOR BAR 75%**: 75% full-field color bar (with 100% white signal)

**SMPTE COLOR BAR:** SMPTE standard color bar

**EIA COLOR BAR:** EIA standard color bar

### Note

When you execute the AUTO menu, SYNC button should be set to OFF (INT SYNC).

EXT SYNC will cause an error abortion of auto adjustment procedure.

## B Adjusting the Color Temperature — COLOR TEMP ADJ Menu

### Overview

The monitor can memorize the data for up to three color temperatures (STD, COL1, COL2.) The data for each color temperature is adjusted with the COLOR TEMP ADJ menu. The data of the color temperature selected in the INPUT CONFIG menu is adjusted. Color temperature adjustment can be made in the following three ways:

#### • Knob adjustment (MANUAL menu)

You can adjust the color temperature with the bias and gain knobs.

#### • Automatic adjustment using a probe (PROBE menu)

You can use the following probes for automatic adjustment of color temperature. Except for the Sony BKM-14L, a cable is required to connect the color analyzer to the monitor.

Manufacturer	Probe Model Name
SONY	BKM-14L (no cable required)
GRASEBY	SLS 9400
MINOLTA	CA-100
PHILIPS	PM 5639
THOMA	TF6

For more information about the cable specification required and about the connection, see "Connection Cable Specifications for Color Temperature Probes" on page 54(E).

### Notes

- The CRT size of the BVM-D9H1U/D9H1E/D9H1A/D9H5U/D9H5E/D9H5A is small. So, when a probe other than the Sony BKM-14L is used, use the probe closely to the CRT screen.
- After the color temperature is adjusted by automatic adjustment, carry out the AUTO adjustment of the CONTROL PRESET ADJ menu (AUTO CHROMA PHASE adjustment.)

#### • Copying other color temperature data (COPY menu)

You can copy the memorized color temperature data (STD/COL1/COL2/D65/D93.) Use the factory setting value or the adjusted value as an original value to shorten the adjustment time.

### Structure of the COLOR TEMP ADJ Menu

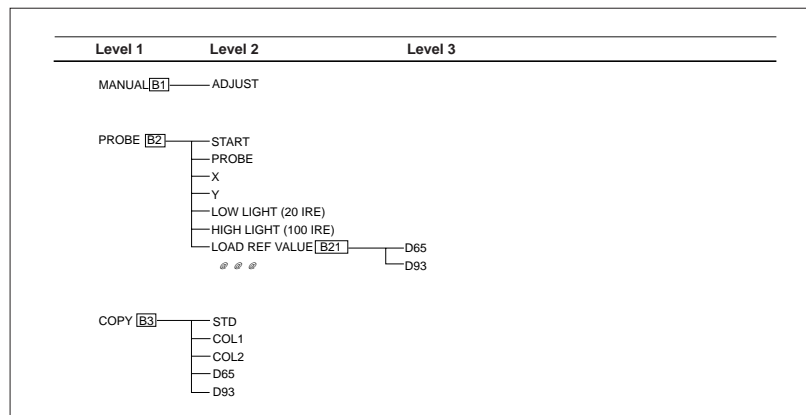

## B Adjusting the Color Temperature — COLOR TEMP ADJ Menu

### Setting Lists in the COLOR TEMP ADJ Menu

This section explains the setting lists displayed in the menu.

#### How to read the setting lists

- For purposes of explanation, each setting list is preceded by a menu number. These numbers are not displayed on the screen.  
*For more information about the menu number, see "About menu numbers" on page 26(E).*
- The arrow mark (⇒) refers you to another setting list that appears after you make the setting, or to an operation that is carried out as a result of the setting. When there is no arrow mark, the menu does not have any sub-list.

#### B1 COLOR TEMP ADJ menu

Select the adjustment method.

**MANUAL...** : Set with the MANUAL adjustment knob. ⇒ B1

**PROBE...** : Set using a probe. ⇒ B2

**COPY...** : Copy data from elsewhere. ⇒ B3

#### B1 MANUAL menu

Adjust the gain and bias with the MANUAL adjustment knob.

**ADJUST...** : Adjust the gain and bias. To shift between gain adjustment and bias adjustment, press UP/DOWN buttons. Use appropriate knobs in each adjustment as described below. After the adjustment, press the ENTER or Ent button to confirm the adjusted values.

**RED:** CONTRAST KNOB (Adjust the R gain or bias with the CONTRAST knob.)

**GREEN:** BRIGHT KNOB (Adjust the G gain or bias with the BRIGHT knob.)

**BLUE:** CHROMA KNOB (Adjust the B gain or bias with the CHROMA knob.)

**LUMINANCE:** PHASE KNOB (Adjust luminance with the PHASE knob.)

#### To reset RED/GREEN/BLUE to the value before adjustment

When you are adjusting the gain or bias using the MANUAL adjustment knobs, you can reset the setting to the one before adjustment by pressing the corresponding MANUAL adjustment button (BVM-D14H5U/D14H5E/D14H5A) or knob (BVM-D9H5U/D9H5E/D9H5A).

To reset all of settings at the same time, press the PHASE button or knob.

#### Note

You cannot reset the setting after you press the ENTER or Ent button.

#### To access the MANUAL menu directly

When the [F2] button is assigned as the short-cut key to the MANUAL menu, you can directly access the MANUAL menu that corresponds to the color temperature setting (STD/COL1/COL2) set to the image on the screen.

*For details of how to assign the short-cut key, see "[E] Setting the Power-Up Conditions and Data about the Screen Display — SYSTEM CONFIG Menu" on page 39(E).*

#### B2 PROBE menu

Select the probe for color temperature adjustment.

**START:** Start adjustment.

**PROBE:** Select the probe.

**X:** Enter the x coordinate.

**Y:** Enter the y coordinate.

**LOW LIGHT (20IRE):** Enter the luminance (cd/m<sup>2</sup>) for low light.

**HIGH LIGHT (100IRE):** Enter the luminance (cd/m<sup>2</sup>) for high light.

**LOAD REF VALUE:** Select the standard settings of the x and y coordinates. ⇒ B21

#### B21 LOAD REF VALUE

Select one of the followings:

**D65:** Use D65 setting (x and y coordinates and standard luminance).

**D93:** Use D93 setting (x and y coordinates and standard luminance).

#### B3 COPY menu

Select one of followings: ⇒ The current data, which is used for adjusting, is copied.

**STD:** Copy STD data (factory setting: D65).

**COL1:** Copy COL 1 data (factory setting: D93).

**COL2:** Copy COL 2 data (factory setting: D65).

**D65:** Copy the color temperature of D65.

**D93:** Copy the color temperature of D93.

#### Note

The current data which is used for adjusting (selected in the INPUT CONFIG menu) is displayed in blue letters and you can not select it.

## C Setting the Input Configuration — INPUT CONFIG Menu

### Overview

You can set up to nine input channels.

Data pertaining to the input signals are set with the INPUT CONFIG menu.

When a channel number (1 to 9) is entered with the numeric keypad, it is then possible to set which input connector on the rear panel will be assigned to that channel number, and select the type of signal that will be connected.

#### To assign D1 serial digital signals

Serial digital signals can be assigned to the slot where the BKM-120D is installed.

#### To assign analog composite signals

Analog composite signals can be assigned to the slot where the BKM-127W is installed.

#### To assign HD serial digital signals

HD serial digital signals can be assigned to the slots where the BKM-142HD is installed.

#### To assign analog component or RGB signals

Analog component or RGB signals can be assigned to the slot where BKM-129X is installed.

### Assigning slot and connector numbers

Set which input connector on which slot will be assigned to the current channel.

### Assigning the signal type and format

The signal type and format which can be assigned to each channel number vary, depending on what adaptors are installed in the rear panel.

### Structure of the INPUT CONFIG Menu

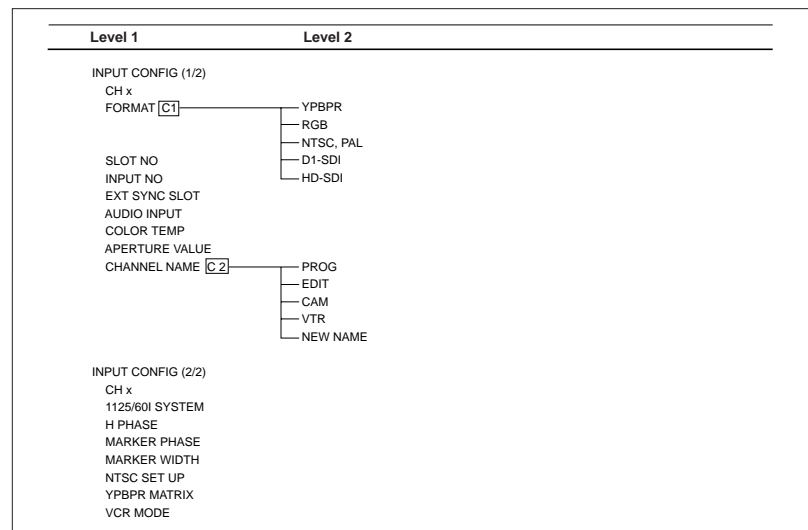

## C Setting the Input Configuration — INPUT CONFIG Menu

### Setting Lists in the INPUT CONFIG Menu

This section explains the setting lists displayed in the menu.

#### How to read the setting lists

- For purposes of explanation, each setting list is preceded by a menu number. These numbers are not displayed on the screen.
- For more information about the menu number, see “About menu numbers” on page 26(E).
- The arrow mark (⇒) refers you to another setting list that appears after you make the setting, or to an operation that is carried out as a result of the setting. When there is no arrow mark, the menu does not have any sub-list.

#### [C] (1/2) INPUT CONFIG (1/2) menu

Set input signal data for each channel.

**CH x:** Current channel is indicated. To change the channel, enter a channel number with the numeric keypad. The settings below will be stored as information of this channel.

**FORMAT... :** Select the input signal type. ⇒ [C1]

**SLOT NO:** Select the slot number.

**INPUT NO:** Select the input connector number.

**EXT SYNC SLOT:** Select the slot when the external sync signal is used.

**AUDIO INPUT (BVM-D9H5U/D9H5E/D9H5A only):** Select the audio input number.

**COLOR TEMP:** Select the color temperature.

**APERTURE VALUE:** Enter the aperture adjustment value (0 to 200).

**CHANNEL NAME:** Give the channel a name. ⇒ [C2]

#### [C] (2/2) INPUT CONFIG (2/2) menu

Set input signal data for each channel.

**CH x:** Current channel is indicated. To change the channel, enter a channel number with the numeric keypad. The settings below will be stored as information of this channel.

**1125/60I SYSTEM:** Select the number of active scanning lines per frame for 1125/60I input signals. When the HD SDI signal is input, the number of active scanning lines is selected automatically.

**1035:** The active scanning lines are 1035 lines.

**1080:** The active scanning lines are 1080 lines

**H PHASE:** Set the horizontal picture position (–128 to +127).

**MARKER PHASE:** Set the 4:3 marker position.

**MARKER WIDTH:** Set the 4:3 marker width.

**NTSC SET UP:** Set the setup level when the BKM-127W is installed. SETUP 7.5 or 0.

**YPBPR MATRIX:** Select the matrix when YPbPr signals of the signal format 480/60I or 480/60P (TV lines 525) are input.

**VCR MODE:** Compensate for a distorted picture when the input signals from the VCR are not typical. This mode is effective when the signal formats 480/60I or 575/50I are input.

**ON:** Operates when the signal formats 480/60I or 575/50I are input.

**OFF:** Does not operate.

#### [C1] FORMAT menu

Select the signal format.

**YPBPR:** Select the component signals when the BKM-129X is installed. SPMTE, BETACAM 7.5 or 0.

**RGB:** Select when the BKM-129X is installed.

**NTSC, PAL:** Selects when the BKM-127W is installed.

**D1-SDI:** Select when the BKM-120D is installed.

**HD-SDI:** Select when the BKM-142D is installed.

#### [C2] CHANNEL NAME menu

Give the channel a name. Enter a name after a preset one or a new one.

**PROG:** Program signal.

**EDIT:** Signal from an editor.

**CAM:** Camera signal.

**VTR:** Signal from a VTR.

**NEW NAME:** Enter a new name. (Up to 20 characters can be entered and up to six characters from the head of the name are displayed in the INPUT CONFIG menu ([C] 1/2).)

## D Assigning the Remote Control Functions — REMOTE Menu

### Overview

The remote control functions are set with the REMOTE menu. With this monitor, both serial remote control (SERIAL REMOTE) and parallel remote control (PARALLEL REMOTE) are possible.

#### • Settings for the serial remote control (SERIAL REMOTE)

An address number (MONITOR ADDRESS) and group number (GROUP ADDRESS) can be assigned to the monitor connected to the SERIAL REMOTE connector.

#### • ON/OFF setting for the parallel remote control (PARALLEL REMOTE)

#### • Settings for the parallel remote control (PARALLEL REMOTE)

Functions can be assigned to the pins of the PARALLEL REMOTE connector.

#### Priority order of the remote control functions

It is possible to simultaneously use the BKM-10R/11R Monitor Control Unit, SERIAL REMOTE, and PARALLEL REMOTE for control, but commands from PARALLEL REMOTE have priority. Therefore, it is impossible for the BKM-10R/11R or SERIAL REMOTE to change items set by PARALLEL REMOTE.

There is no priority order between commands from SERIAL REMOTE and the BKM-10R/11R control panel.

PARALLEL REMOTE [1] and [2] are connected parallel inside the unit, therefore, there is no priority order between them.

### About monitor address and group numbers

It is possible to control up to 32 monitors connected via serial remote connector (using the SERIAL REMOTE connector). By giving each monitor a monitor address and group number, it is possible to control just a specific monitor or monitor group. With the SERIAL REMOTE menu, each monitor can be set with a monitor address and group number, between 1 and 99. The ADDRESS menu is used to control the monitors which are connected by the serial remote connectors.

For information about the ADDRESS menu, see “Selecting the Monitor to Control — ADDRESS Menu” on page 45(E).

#### Note

The address number must differ from one monitor to another. If two or more monitors have the same address number, an operation error occurs.

### Structure of the REMOTE Menu

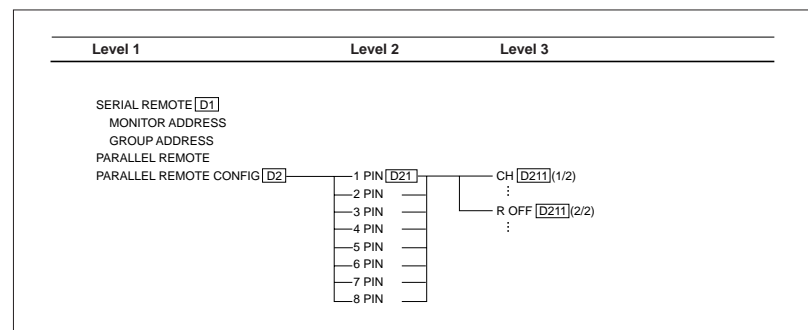

## D Assigning the Remote Control Functions — REMOTE Menu

### Setting Lists of the REMOTE Menu

This section explains the setting lists displayed in the menu.

#### How to read the setting lists

- For purposes of explanation, each setting list is preceded by a menu number. These numbers are not displayed on the screen.
- For more information about the menu number, see "About menu numbers" on page 26(E).
- The arrow mark (⇒) refers you to another setting list that appears after you make the setting, or to an operation that is carried out as a result of the setting. When there is no arrow mark, the menu does not have any sub-list.

#### D REMOTE menu

Select the type of remote control.

**SERIAL REMOTE** : Set the address and group number of the monitor controlled via the SERIAL REMOTE connector. ⇒ **[D1]**

**PARALLEL REMOTE** : Select whether parallel remote control will be used or not (ON or OFF.)

**PARALLEL REMOTE CONFIG** : Set the pin assignments for the PARALLEL REMOTE connector. ⇒ **[D2]**

#### D1 SERIAL REMOTE menu

Set the monitor address and group number.

**MONITOR ADDRESS**: Enter a number.

**GROUP ADDRESS**: Enter a number.

#### D2 PARALLEL REMOTE CONFIG menu

Select the PARALLEL REMOTE connector pins for which you want to change the function. The factory settings for each pin are given below. ⇒ **[D21]**

PINs 1 to 4, and PIN 6 of the PARALLEL REMOTE **[1]** and **[2]** are common settings.

**1 PIN**: CH01

**2 PIN**: CH02

**3 PIN**: TALLY RED

**4 PIN**: TALLY GREEN

**5 PIN**: EXT SYNC (PARALLEL REMOTE **[1]**)  
GND (PARALLEL REMOTE **[2]**)

**6 PIN**: UNDERSCAN

**7 PIN**: 16:9

**8 PIN**: 4:3 MARKER

#### Note

PINs 1 to 4, and PIN 6 of the PARALLEL REMOTE **[1]** and **[2]** are connected inside the unit, therefore different functions cannot be assigned to those pins.

#### D211 (1/2) 1-8 PIN menu (1/2)

Assign a function to the selected pin.

**CH**: Select a channel number. Enter the desired channel number with the numeric keypad.

----: Set to unused.

**UNDER SCAN**: Set underscan on or off.

**16:9**: Set a 16:9 aspect ratio on or off.

**H DELAY**: Set the horizontal sync display on or off.

**V DELAY**: Set the vertical sync display on or off.

**EXT SYNC**: Set the synchronization to external sync signals enabled or disabled.

**APERTURE**: Set the correction of frequency characteristics enabled or disabled.

**MONO**: Set monochrome display on or off.

**BLUE ONLY**: Set the blue signal pictures display (monochrome) on or off.

#### D211 (2/2) 1-8 PIN menu (2/2)

Assign a function to the selected pin.

**R OFF**: Set cutting red beams enabled or disabled.

**G OFF**: Set cutting green beams enabled or disabled.

**B OFF**: Set cutting blue beams enabled or disabled.

**4:3 MARKER**: Set the 4:3 marker display on or off.

**CAPTION VISION**: Set Caption Vision on or off.

**TALLY RED**: Set tally red on or off.

**TALLY GREEN**: Set tally green on or off.

**DEGAUSS**: Set degaussing on or off.

**POWER OFF**: Set the monitor power on or off.

For the pin assignment, see "PARALLEL REMOTE **[1]**/**[2]** connectors" in the Location and Function of Parts on page 13(E) for BVM-D9H1U/D9H1E/D9H1A/D9H5U/D9H5E/D9H5A or page 22(E) for BVM-D14H1U/D14H1E/D14H1A/D14H5U/D14H5E/D14H5A.

## E Setting the Power-Up Conditions and Data about the Screen Display — SYSTEM CONFIG Menu

### Overview

The SYSTEM CONFIG menu is displayed on the two pages.

The SYSTEM CONFIG (1/2) menu is used for the following settings:

- Power-up condition (STANDBY MODE menu)**  
This menu sets the condition of the monitor when the MAIN POWER switch on the rear panel is switched on (BVM-D14H1U/D14H1E/D14H1A/D14H5U/D14H5E/D14H5A) or when the battery is installed (BVM-D9H1U/D9H1E/D9H1A/D9H5U/D9H5E/D9H5A.)

- Power-up input channel (DEFAULT CH menu)**  
This menu sets the power-up input channel.

- Time from power-up until degauss (DEGAUSS DELAY menu)**

If several monitors are turned on at the same time and all start degaussing at the same time, there will be a very large current draw on the power supply for a few moments. To prevent this, the delay time between power-up and degaussing can be set for each monitor independently.

- Setting of the contrast and brightness after adjusting the white balance (CONT/BRT HOLD menu)**

Selects if the adjusted contrast and brightness are retained or they are reset to the center values, when the color temperature is adjusted in the COLOR TEMP ADJ menu.

- Assigning shortcut to the COLOR TEMP ADJ menu to the **[F2]** key (COL TEMP SHORT-CUT menu)**

Assigns the shortcut to the MANUAL menu of the COLOR TEMP ADJ menu to the **[F2]** key. This allows you to jump directly to the MANUAL menu corresponding to the color temperature set to the currently displayed image (STD/COL 1/COL 2.)

- Auto color control (ACC SW menu) (when using the BKM-127W)**

Selects if the ACC (Auto Color Control) circuit is turned on or off.

- Selecting the monitor to copy the original data (CONFIG COPY menu)**

Setting data of the INPUT CONFIG and SYSTEM CONFIG (except the DEGAUSS DELAY data) menus can be copied from the serial connected

monitor.

The SYSTEM CONFIG (2/2) menu is used for the following settings:

- Display mode and position of the signal format (FORMAT DISPLAY and POSITION menus)**
- Display mode and position of the channel number (CH NO and POSITION menus)**
- Display mode and position of the channel name (CH NAME and POSITION menus)**
- Display mode of the caption (CAPTION menu)**

- Maintenance (MAINTENANCE menu)**

This is for a service qualified personnel.

## Setting the Power-Up Conditions and Data about the Screen Display — SYSTEM CONFIG Menu

### Structure of the SYSTEM CONFIG Menu

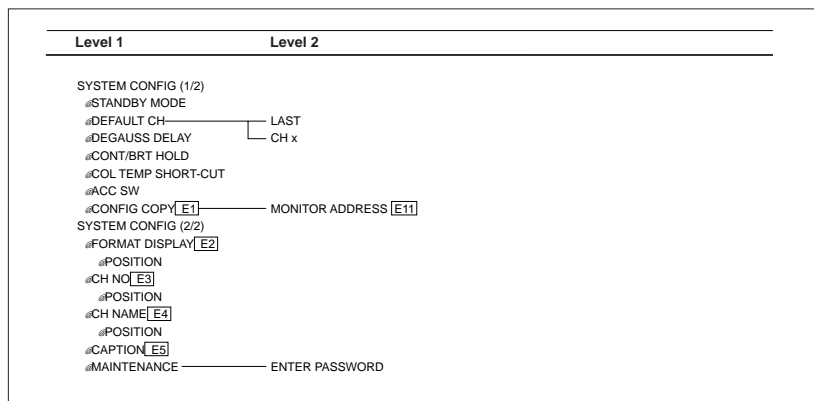

### Setting Lists of the SYSTEM CONFIG Menu

This section explains the setting lists displayed in the menu.

#### How to read the setting lists

- For purposes of explanation, each setting list is preceded by a menu number. These numbers are not displayed on the screen.
- For more information about the menu number, see "About menu numbers" on page 26(E).
- The arrow mark (⇒) refers you to another setting list that appears after you make the setting, or to an operation that is carried out as a result of the setting. When there is no arrow mark, the menu does not have any sub-list.
- The factory setting is shown in the brackets.

#### [E] (1/2) SYSTEM CONFIG (1/2) menu

Set each of the following items.

**STANDBY MODE:** Select the power-up condition when the MAIN POWER switch is turned on (BVM-D14H1U/D14H1E/D14H1A/D14H5U/D14H5E/D14H5A) or when the battery is installed (BVM-D9H1U/D9H1E/D9H1A/D9H5U/D9H5E/D9H5A.)

**ON:** Standby mode  
**[OFF]:** Operation mode

**DEFAULT CH:** Select the power-up input channel (LAST or CH x).

**[LAST]:** Set the channel to the channel that was selected at the time the power was last turned off.

**CH x:** Set the channel to a specific channel number.

**DEGAUSS DELAY:** Set the time between power-up and the beginning of degaussing. Enter the desired time (in seconds, 0 to 255).

**CONT/BRT HOLD:** Select the contrast and brightness settings to the center or adjusted value after adjusting the white balance or auto adjustment of CONTROL PRESET ADJ (OFF or ON).

**ON:** The contrast and brightness are set to the value before adjusting.

**[OFF]:** The contrast and brightness are set to the center value (100) after adjusting.

**COL TEMP SHORT-CUT:** Assign the shortcut function to the MANUAL menu of the COLOR TEMP ADJ menu to [F2] key (OFF or F2).

**F2:** Assigns the shortcut to the MANUAL menu of the COLOR TEMP ADJ menu.

**[OFF]:** Does not assign the shortcut to the MANUAL menu of the COLOR TEMP ADJ menu.

**ACC SW:** Set the automatic color control switch (OFF or ON).

**CONFIG COPY...:** Copy setting data of the INPUT CONFIG and SYSTEM CONFIG (except the DEGAUSS DELAY data) menus from the serial connected BVM-D9H/D14H monitor. ⇒ [E11]

#### [E11] MONITOR ADDRESS menu

Set the address number of the monitor to be copied.

#### [E] (2/2) SYSTEM CONFIG (2/2) menu

Select items to be displayed on the screen.

**FORMAT DISPLAY:** Select the display mode of the signal format. ⇒ [E2] (2/2)

**POSITION:** Select the display position of the signal format. ⇒ [E2] (2/2)

**CH NO:** Select the display mode of the channel number. ⇒ [E3] (2/2)

**POSITION:** Select the display position of the channel number. ⇒ [E3] (2/2)

**CH NAME:** Select the display mode of the channel name. ⇒ [E4] (2/2)

**POSITION:** Select the display position of the channel name. ⇒ [E4] (2/2)

**CAPTION:** Select the caption display mode. ⇒ [E5] (2/2)

**MAINTENANCE...:** Menu for service personnel.

#### [E2] (2/2) FORMAT DISPLAY and POSITION menus

##### FORMAT DISPLAY menu

Select the display mode of the signal format.

**[AUTO]:** Disappears after displayed for a while.

**ON:** Displayed.

**OFF:** Not displayed.

##### POSITION menu

Select the display position.

[BOTTOM LEFT]  
 BOTTOM CENTER  
 BOTTOM RIGHT  
 TOP LEFT  
 TOP CENTER  
 TOP RIGHT

#### [E3] (2/2) CH NO and POSITION menus

##### CH NO menu

Select the display mode of the channel number.

**[AUTO]:** Disappears after displayed for a while.

**ON:** Displayed.

**OFF:** Not displayed.

##### POSITION menu

Select the display position.

BOTTOM LEFT  
 BOTTOM CENTER  
 [BOTTOM RIGHT]  
 TOP LEFT  
 TOP CENTER  
 TOP RIGHT

#### [E4] (2/2) CH NAME and POSITION menus

##### CH NAME menu

Select the display mode of the channel name.

**[AUTO]:** Disappears after displayed for a while.

**ON:** Displayed.

**OFF:** Not displayed.

##### POSITION menu

Select the display position.

BOTTOM LEFT  
 BOTTOM CENTER  
 BOTTOM RIGHT  
 [TOP LEFT]  
 TOP CENTER  
 TOP RIGHT

#### [E5] (2/2) CAPTION menu

Select the caption display mode.

**[OFF]:** Not displayed

**CAPTION 1:** Displayed in CAPTION 1 mode.

**CAPTION 2:** Displayed in CAPTION 2 mode.

**TEXT 1:** Displayed in TEXT 1 mode.

**TEXT 2:** Displayed in TEXT 2 mode.

## F Displaying Information About the Monitor — STATUS Menu

### Overview

The STATUS menu is used to view general data about the monitor and information about signals assigned to the slots in the rear panel.

The following information is displayed on the two pages of the STATUS menu.

- **Data about the current channel (STATUS menu (1/2))**
- **Data about the monitor in use and data about the input adaptors installed into the slots on the rear panel (STATUS menu (2/2))**

### Structure of the STATUS Menu

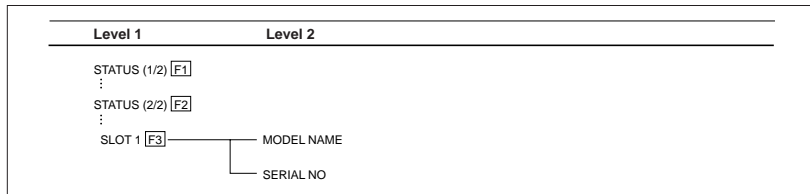

### Setting Lists of the STATUS Menu

This section explains the setting lists displayed in the menu.

#### How to read the setting lists

- For purposes of explanation, each setting list is preceded by a menu number. These numbers are not displayed on the screen.

*For more information about the menu number, see "About menu numbers" on page 26(E).*

- The arrow mark (⇒) refers you to another setting list that appears after you make the setting, or to an operation that is carried out as a result of the setting. When there is no arrow mark, the menu does not have any sub-list.

#### [F] STATUS menu

Select the STATUS menu 1/2 or 2/2. ⇒ [F1]

#### [F1] STATUS (1/2) menu

Data about the current channel is displayed.

**CH:** channel number

**SL:** slot number

**IN:** input connector number

**FORMAT:** format of the input signal

**NAME:** channel name

#### [F2] STATUS (2/2) menu

Data about the monitor is displayed at the upper half of the display.

**MODEL NAME:** model name

**SERIAL NO:** serial number

**OPERATION TIME:** operation time (in hours)

**SOFTWARE VERSION:** software version

Data about the input adaptors installed into the respective slots in the rear panel is displayed at the lower half of the display.

When the BKM-129X is installed in SLOT 1, the following is displayed. When any optional boards are not installed, EMPTY is displayed for SLOT 2 and SLOT 3.

**SLOT1: COMPONENT** ⇒ [F3]

**SLOT2: EMPTY** ⇒ [F3]

**SLOT3: EMPTY** ⇒ [F3]

#### [F3] SLOT 1 to 3 menu

Select the desired slot. Data about the optional board installed in the selected slot is displayed.

**MODEL NAME:** Model name of that optional board

**SERIAL NO:** Serial number of that circuit board

## G Adjusting the Position, Size and Geometry of the Picture — ALIGNMENT Menu

### Overview

The ALIGNMENT menu is used for adjusting the position, size and geometry of the picture.

### Structure of the ALIGNMENT Menu



### Setting Lists of the ALIGNMENT Menu

This section explains the setting lists displayed in the menu.

#### How to read the setting lists

- For purposes of explanation, each setting list is preceded by a menu number. These numbers are not displayed on the screen.

*For more information about the menu number, see "About menu numbers" on page 26(E).*

## Ⓜ Adjusting the Position, Size and Geometry of the Picture — ALIGNMENT Menu

### Ⓜ ALIGNMENT menu

Adjust the position, size or geometry of the picture with the UP and DOWN buttons or PHASE knob.

**V SIZE:** Adjust the height of the picture.

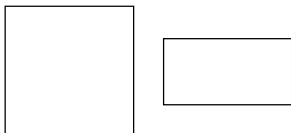

**V CENTER:** Adjust the vertical picture position.



**H SIZE:** Adjust the width of the picture.



**H PHASE:** Adjust the horizontal picture position.



**H PIN:** Correct side pincushion distortion.

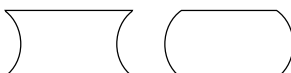

**H KEY:** Correct trapezoid distortion.



## Selecting the Monitor to Control — ADDRESS Menu

### Overview

When multiple monitors are connected by a serial remote connection, the ADDRESS menu is used to choose whether one particular monitor or monitor group will be controlled, or whether operations are to be performed on all monitors together.

### Displaying the ADDRESS Menu

Press the ADDRESS button.  
The ADDRESS menu is displayed on the screen.  
By pressing the ENTER or Ent button after selecting the item, serial remote operation becomes activated.

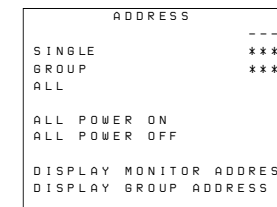

ADDRESS Menu

Settings made with the menu items are as follows:

Item	Function
SINGLE	Controls only a specified monitor. Enter the monitor address number.
GROUP	Controls only a specified monitor group. Enter the group address number.
ALL	Controls all monitors.
ALL POWER ON	Turns all connected monitors on.
ALL POWER OFF	Turns all connected monitors off.
DISPLAY MONITOR ADDRESS	When this item is selected, each connected monitor displays its monitor address on its screen.
DISPLAY GROUP ADDRESS	When this item is selected, each connected monitor displays its group address on its screen.

### Notes

- To remotely control monitors connected in serial, MONITOR ADDRESS or GROUP ADDRESS of monitors should be correctly set in the REMOTE menu.  
For details of the REMOTE menu, see "[E] Assigning the Remote Control Functions – REMOTE Menu" on page 37(E).
- In GROUP or ALL mode, the LEDs of the function buttons will not light with controlled from the menu. (LEDs light only when you press the function button.)
- In GROUP or ALL mode, LEDs of controlled monitor will light as follows.

- In case of SHIFT OFF before remote control operation:** LEDs light in green when the SHIFT button is remotely set to OFF.  
For details, see "SHIFT button" on page10(E) for BVM-D9H5U/D9H5E/D9H5A or on page 19(E) for BVM-D14H5U/D14H5E/D14H5A.
- In case of SHIFT ON before remote control operation:** LEDs light in amber when the SHIFT button is remotely set to ON.  
For details, see "SHIFT button" on page11(E) for BVM-D9H5U/D9H5E/D9H5A or on page 20(E) for BVM-D14H5U/D14H5E/D14H5A.

(continued)

## Selecting the Monitor to Control — ADDRESS Menu

### Canceling the Remote Control Mode

To cancel the remote control mode, press the ADDRESS button.

### Exiting the ADDRESS Menu

To exit the ADDRESS menu, press the ADDRESS button or the MENU button.

### Short-cut Function in the ADDRESS Menu

When selecting the monitor, short-cut function will enable to select the target monitor without using the items in the ADDRESS menu. The operation procedure is as follows.

#### To select the monitor in the SINGLE mode

- 1 Press the ADDRESS button.
- 2 Press the address number of the target monitor. Press one digit address number on the numeric keypad when it is from 1 to 9. Press three digits address number (press 0 button and then press the two-digit address number) when it is from 10 to 99.

#### To select the monitors in the GROUP mode

- 1 Press the ADDRESS button.
- 2 Press the F1 button.
- 3 Press the group number of the target monitor. Press one digit group address number when it is from 1 to 9. Press three digits group address number (press 0 button and then press the two-digit group number) when it is from 10 to 99.

#### To select all the monitors in the ALL mode

- 1 Press the ADDRESS button.
- 2 Press the F2 button.

## Specifications

### General

System 15.625 kHz – 45 kHz  
(For details, see "Available Signal Format" on page 53(E).)

### CRT

#### BVM-D9H1U/D9H1E/D9H1A/D9H5U/D9H5E/D9H5A

HR Trinitron, 4:3 aspect ratio  
Aperture grille pitch: 0.25 mm  
90 degree deflection, 21.6 mm diameter in-line gun  
Effective picture size with 16:9 aspect ratio:  
155.4 × 87.4 mm (6 1/8 × 3 1/2 inches) (w/h)  
178 mm (7 inches) (diagonal size)  
Effective picture size with 4:3 aspect ratio:  
155.4 × 115 mm (6 1/8 × 4 5/8 inches) (w/h)  
190.7 mm (7 1/2 inches) (diagonal size)  
CRT protection: EHT (extremely high tension) protection type  
Warm-up time: approx. 30 minutes  
Anode voltage: 15 kV with no beam current

#### BVM-D14H1U/D14H1E/D14H1A/D14H5U/D14H5E/D14H5A

HR Trinitron, 4:3 aspect ratio  
Aperture grille pitch: 0.25 mm  
90 degree deflection, 29.4 mm diameter in-line gun  
Effective picture size with 16:9 aspect ratio:  
267.5 × 150.5 mm (10 5/8 × 6 inches) (w/h)  
306.9 mm (12 1/8 inches) (diagonal size)  
Effective picture size with 4:3 aspect ratio:  
267.5 × 200.6 mm (10 5/8 × 8 inches) (w/h)  
331.6 mm (13 1/8 inches) (diagonal size)  
CRT protection: EHT (extremely high tension) protection type  
Warm-up time: approx. 30 minutes  
Anode voltage: 23 kV with no beam current

Nominal chromaticity coordinates:

EBU phosphor		
	x	y
R	0.640	0.330
G	0.290	0.600
B	0.150	0.060

Dimensions (w/h/d)

BVM-D9H1U/D9H1E/D9H1A:  
approx. 217 × 174 × 364.5mm  
(8 5/8 × 6 7/8 × 14 3/8 inches)  
when the AC adaptor is installed:  
approx. 217 × 174 × 419.5mm  
(8 5/8 × 6 7/8 × 16 5/8 inches)  
BVM-D9H5U/D9H5E/D9H5A:  
approx. 217 × 218 × 364.5mm  
(8 5/8 × 8 5/8 × 14 3/8 inches)  
when the AC adaptor is installed:  
approx. 217 × 218 × 419.5mm  
(8 5/8 × 8 5/8 × 16 5/8 inches)  
BVM-D14H1U/D14H1E/D14H1A:  
approx. 346 × 280 × 519mm  
(13 5/8 × 11 1/8 × 20 1/2 inches)  
BVM-D14H5U/D14H5E/D14H5A:  
approx. 482 × 280 × 519mm  
(19 × 11 1/8 × 20 1/2 inches)



## Specifications

### Dimensional drawing

#### BVM-D9H1U/D9H1E/D9H1A

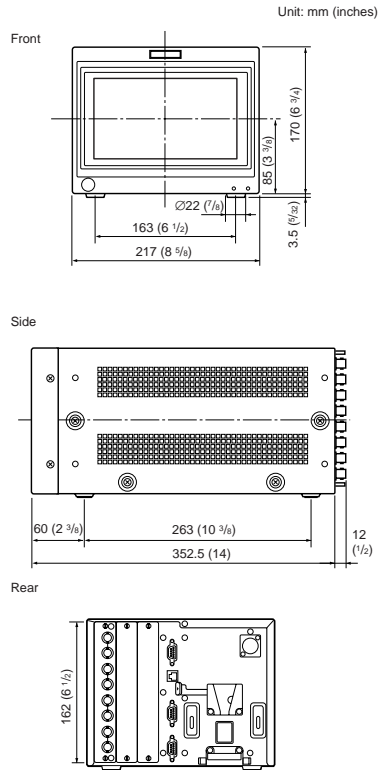

#### BVM-D9H5U/D9H5E/D9H5A

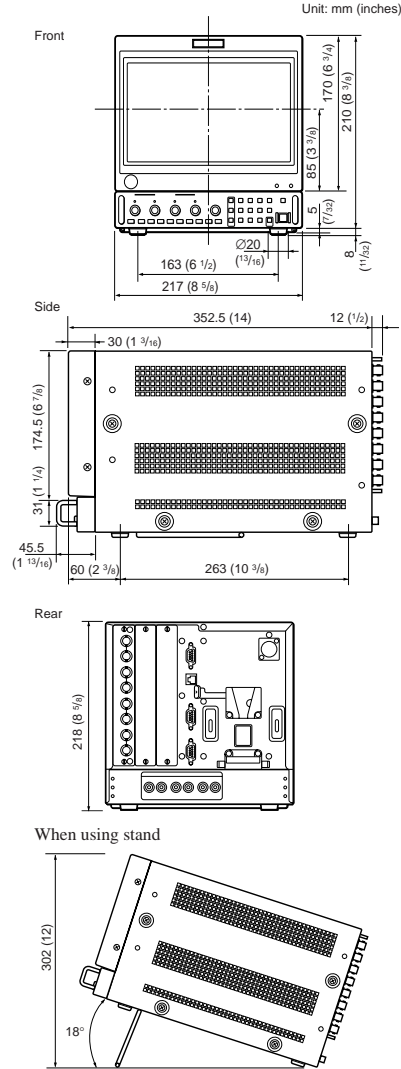

#### BVM-D14H1U/D14H1E/D14H1A

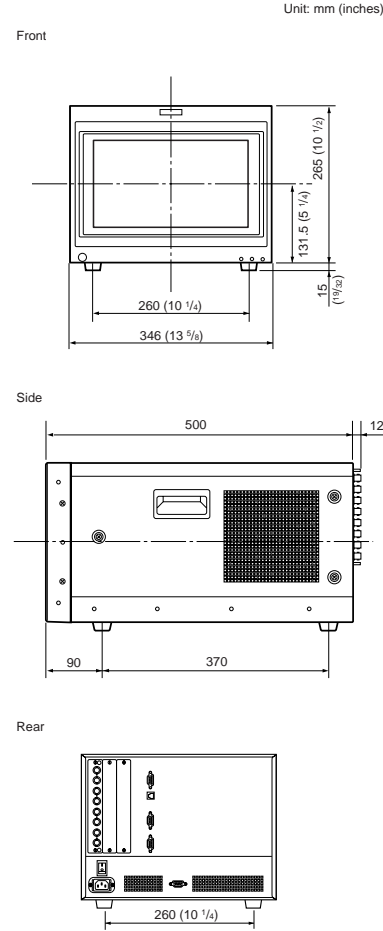

#### BVM-D14H5U/D14H5E/D14H5A

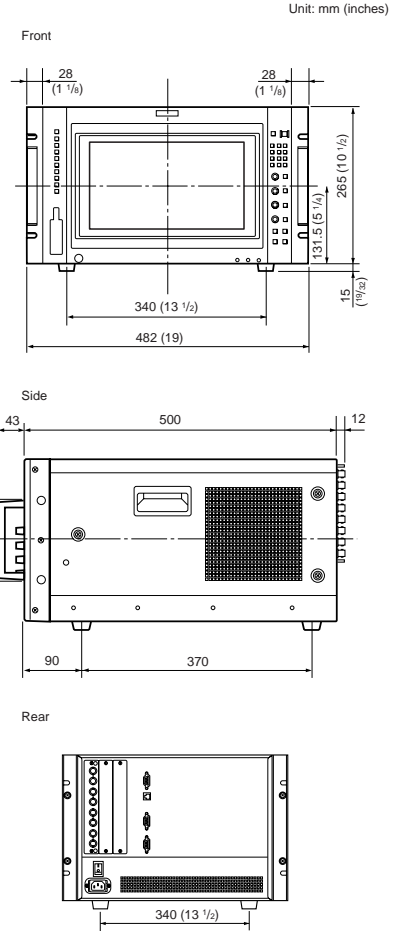

## Specifications

<p><b>Mass</b></p> <p>BVM-D9H1U/D9H1E/D9H1A: approx. 8.1 kg (17 lb 14 oz) when the AC adaptor is installed: approx. 8.9 kg (19 lb 10 oz)</p> <p>BVM-D9H5U/D9H5E/D9H5A: approx. 9.3 kg (20 lb 8 oz) when the AC adaptor is installed: approx. 10.1 kg (22 lb 4 oz)</p> <p>BVM-D14H1U/D14H1E/D14H1A: approx. 21 kg (46 lb 5 oz)</p> <p>BVM-D14H5U/D14H5E/D14H5A: approx. 23 kg (50 lb 11 oz)</p> <p><b>Power consumption</b></p> <p>BVM-D9H1U/D9H1E/D9H1A/ D9H5U/D9H5E/D9H5A: 85 W max. (an optional BKM-142HD or BKM-120D is installed) 60 W typical (the supplied analog component input adaptor is installed)</p> <p>BVM-D14H1U/D14H1E/D14H1A/ D14H5U/D14H5E/D14H5A: 115 W max. (an optional BKM-142HD or BKM-120D is installed) 100 W typical (the supplied analog component input adaptor is installed)</p> <p><b>Peak inrush current</b></p> <p>(1) Power ON, current probe method: 80 A (240 V) (BVM-D9H1U/D9H1E/D9H1A/D9H5U/D9H5E/D9H5A), 45 A (240 V) (BVM-D14H1U/D14H1E/D14H1A/D14H5U/D14H5E/D14H5A)</p> <p>(2) Hot switching inrush current, measured in accordance with European standard EN55103-1: 10 A (230 V) (BVM-D9H1U/D9H1E/D9H1A/D9H5U/D9H5E/D9H5A), 20 A (230 V) (BVM-D14H1U/D14H1E/D14H1A/D14H5U/D14H5E/D14H5A)</p>	<p><b>Power requirements</b></p> <p>BVM-D9H1U/D9H1E/D9H1A/ D9H5U/D9H5E/D9H5A: AC 100 to 240 V, 50/60 Hz, DC 12V<sup>⚡</sup> V</p> <p>BVM-D14H1U/D14H1E/D14H1A/ D14H5U/D14H5E/D14H5A: AC 100 to 240 V, 50/60 Hz</p> <p><b>Input/output connectors</b></p> <p><b>Video input/output</b> BNC type × 3 (with loop-through outputs, 75-ohm automatic termination) R/G/B: 1 Vp-p ±6 dB, positive, high impedance Y: 1 Vp-p ±6 dB, high impedance Pb/Pr: 0.7 Vp-p ±6 dB, high impedance</p> <p><b>Sync input/output</b> BNC type × 1 (with loop-through output, 75-ohm automatic termination) Composite sync: 0.3 to 8 Vp-p, positive/negative tri-level sync signal input or negative bi-level sync signal input, high impedance</p> <p><b>Return loss</b> More than 40 dB (10 MHz, with 75-ohm termination)</p> <p><b>Remote control</b> OPTION: Mini-DIN 8-pin × 1 CONTROL UNIT: D-sub 9-pin × 1 (BVM-D9H1U/D9H1E/D9H1A<sup>1)</sup>, BVM-D14H1U/D14H1E/D14H1A only) PARALLEL REMOTE [1]: D-sub 9-pin × 1 PARALLEL REMOTE [2]: Modular connector 6-pin SERIAL REMOTE: D-sub 9-pin × 2<sup>1)</sup> (with loop-through output)</p> <p><b>Audio input</b> (BVM-D9H5U/D9H5E/D9H5A only) Phono jack × 3 (with loop-through output)</p>
---	--

1) BVM-D9H1U/D9H1E/D9H1A is switched to REMOTE or CTRL UNIT with the select switch.

## Video signal

<b>Frequency response</b>	575/50I, 480/60I component inputs BVM-D9H1U/D9H1E/D9H1A/ D9H5U/D9H5E/D9H5A/ D14H1U/D14H1E/D14H1A/ D14H5U/D14H5E/D14H5A: 50Hz to 10MHz (0 dB/-3 dB)
<b>Aperture compensation<sup>2)</sup></b>	Models other than the above or RGB inputs BVM-D9H1U/D9H1E/D9H1A/ D9H5U/D9H5E/D9H5A: 48 Hz to 17 MHz, (1 dB/-3 dB) BVM-D14H1U/D14H1E/ D14H1A/D14H5U/D14H5E/ D14H5A: 48 Hz to 24 MHz, (0 dB/-3 dB) OFF: 0 dB ON: 2 dB to 6 dB 575/50I, 480/60I inputs: 5 MHz Input other than the above: 16 MHz

## Picture performance

<b>Normal scan</b>	5% overscan of CRT effective screen area (adjustable range greater than ±15%)
<b>Underscan</b>	3% underscan of CRT effective screen area (adjustable range greater than ±15%)
<b>Linearity</b>	Within a central area bounded by a circle with a diameter equal to the picture height, less than 1.0 % of the picture height, and outside the same area, about 2.0 % of the picture height
<b>Color temperature</b>	D93, D65 (adjustable to other color temperatures)

2) The aperture cannot be compensated for RGB input signals.

<b>Convergence error</b>	Within a central area bounded by a circle with a diameter equal to the picture height. Less than 0.4 mm with a central area bounded by a circle and less than 0.7 mm at any other point.
<b>Standard luminescence</b>	120 cd/m <sup>2</sup> (at standard 1 Vp-p 100% white signal)
<b>Raster size stability</b>	Less than 1% of picture height (at 120 cd/m <sup>2</sup> peak luminescence, 10 to 90% APL)
<b>Resolution</b> (at screen center, 120 cd/m <sup>2</sup> luminescence)	BVM-D9H1U/D9H1E/D9H1A/ D9H5U/D9H5E/D9H5A: 340 TV lines (16:9) 450 TV lines (4:3) BVM-D14H1U/D14H1E/D14H1A/ D14H5U/D14H5E/D14H5A: 600 TV lines (16:9) 800 TV lines (4:3)

## Operating conditions

<b>Temperature</b>	0°C to 35°C (32°F to 95°F)
<b>Optimum temperature</b>	20°C to 30°C (68°F to 86°F)
<b>Humidity</b>	0% to 90% (no condensation)
<b>Pressure</b>	700 hPa to 1060 hPa

## Storage and transport conditions

<b>Temperature</b>	-10°C to 40°C (14°F to 104°F)
<b>Humidity</b>	0% to 90%
<b>Pressure</b>	700 hPa to 1060 hPa



## Specifications

### Accessories supplied

AC power cord (1)  
 AC adaptor (1) (BVM-D9H1U/D9H1E/D9H1A/  
 D9H5U/D9H5E/D9H5A only)  
 AC plug holder (1)  
 Tally plate (1)  
 4:3 mask (1)  
 Operation manual (1)

### Acquired safety regulations

UL1950, CSA950  
 FCC Class A, IC Class A  
 DHHS, DNHW  
 TÜV (EN60950), PTB  
 CE-Marking, C-tick Mark

Design and specifications are subject to change without notice.

### Available Signal Format

System	Total lines per frame	Active lines per frame	** Frame rate (Hz)	Scanning format	Aspect	Standard
575/50I (*PAL)	625	575	25	2:1 interlace	16:9/4:3	ITU 601
480/60I (*NTSC)	525	483	30	2:1 interlace	16:9/4:3	ITU 601
575/50P	625	575	50	Progressive	16:9/4:3	–
480/60P	525	483	60	Progressive	16:9/4:3	SMPTE 293M
1080/48I	1125	1080	24	2:1 interlace	16:9	–
1080/50I	1125	1080	25	2:1 interlace	16:9	SMPTE 294M
1035/60I	1125	1035	30	2:1 interlace	16:9	BTA S-001B
1080/60I	1125	1080	30	2:1 interlace	16:9	SMPTE 274M/BTA S-001B
720/60P	750	720	60	Progressive	16:9	SMPTE 296M

\* Available when the optional adaptor is installed.

\*\* Also compatible with  $\frac{1}{1.001}$ .



Specifications

Connection Cable Specifications for Color Temperature Probes

Special cables are required to connect color temperature probes other than the Sony BKM-14L to the monitor.

The following diagrams show specifications and pin assignments for the required cables.

Connection cable for GRASEBY SLS 9400 probe

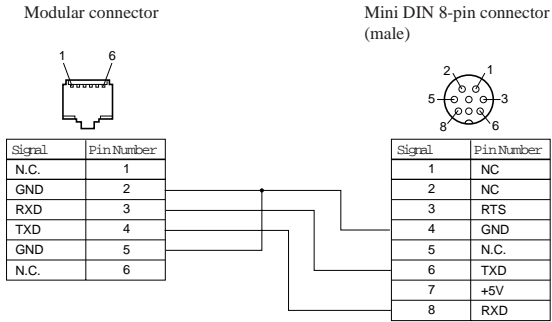

Connection cable for MINOLTA CA-100 probe

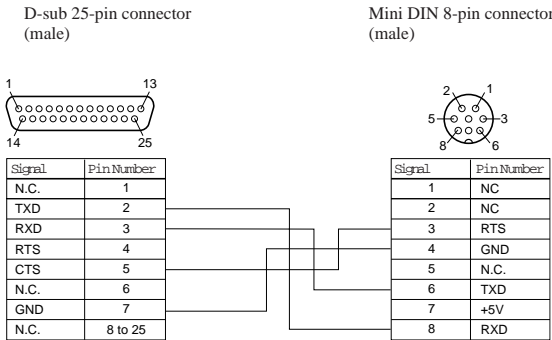

Connection cable for PHILIPS PM 5639 probe (corresponds to PHILIPS PM 5639/64 cable)

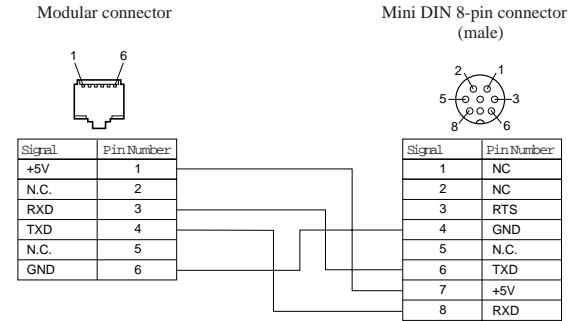

Connection cable for THOMA TF6 probe

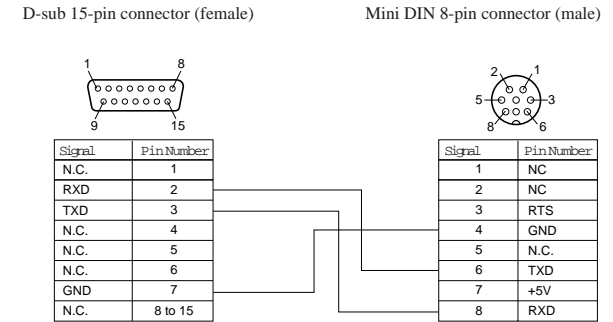

# Menu Index

The menu index shows the menu items provided with this monitor in alphabetical order. For your reference, each menu item is followed by the page of this manual on which the item is explained, its menu number, and the Main Menu that the item belongs to.

Menu Item	Page	Menu number	Main menu
A ACC SW	41(E)	-	SYSTEM CONFIG menu
ADDRESS	45(E)	-	ADDRESS menu
ADJUST	34(E)	-	COLOR TEMP ADJ menu
ALIGNMENT	44(E)	[G]	ALIGNMENT menu
APERTURE VALUE	36(E)	-	INPUT CONFIG menu
AUDIO INPUT	36(E)	-	INPUT CONFIG menu
AUTO	32(E)	[A2]	CONTROL PRESET ADJ menu
B BRIGHT	32(E)	-	CONTROL PRESET ADJ menu
C CAM	36(E)	-	INPUT CONFIG menu
CAPTION	41(E)	[E5]	SYSTEM CONFIG menu
CH	38(E)	[D211]	REMOTE menu
CH NAME	40(E)	-	SYSTEM CONFIG menu
CH NO	41(E)	[E4]	SYSTEM CONFIG menu
CHANNEL NAME	41(E)	[E3]	SYSTEM CONFIG menu
CHROMA	36(E)	[C2]	INPUT CONFIG menu
COL TEMP SHORT-CUT	32(E)	-	CONTROL PRESET ADJ menu
COL1	41(E)	-	SYSTEM CONFIG menu
COL2	34(E)	-	COLOR TEMP ADJ menu
COLOR TEMP	34(E)	-	COLOR TEMP ADJ menu
COLOR TEMP ADJ	36(E)	-	INPUT CONFIG menu
CONFIG COPY	33(E)	[B]	COLOR TEMP ADJ menu
CONT/BRT HOLD	41(E)	[E1]	SYSTEM CONFIG menu
CONTRAST	41(E)	-	SYSTEM CONFIG menu
CONTROL PRESET ADJ	32(E)	-	CONTROL PRESET ADJ menu
COPY	31(E)	[A]	CONTROL PRESET ADJ menu
	34(E)	[B3]	COLOR TEMP ADJ menu
D D1-SDI	36(E)	-	INPUT CONFIG menu
D65	34(E)	-	COLOR TEMP ADJ menu
D93	34(E)	-	COLOR TEMP ADJ menu
DEFAULT CH	40(E)	-	SYSTEM CONFIG menu
DEGAUSS DELAY	40(E)	-	SYSTEM CONFIG menu
E EDIT	36(E)	-	INPUT CONFIG menu
EIA COLOR BAR	32(E)	-	CONTROL PRESET ADJ menu
ENTER PASSWORD	40(E)	-	SYSTEM CONFIG menu
EXT SYNC SLOT	36(E)	-	INPUT CONFIG menu
F FORMAT	36(E)	[C1]	INPUT CONFIG menu
FORMAT DISPLAY	41(E)	[E2]	SYSTEM CONFIG menu
FULL FIELD WHITE 100 %	31(E)	-	CONTROL PRESET ADJ menu
G GROUP ADDRESS	38(E)	-	REMOTE menu
H H KEY	44(E)	-	ALIGNMENT menu
H SIZE	44(E)	-	ALIGNMENT menu
H PHASE	36(E)	-	INPUT CONFIG menu
	44(E)	-	ALIGNMENT menu
H PIN	44(E)	-	ALIGNMENT menu
HD-SDI	36(E)	-	INPUT CONFIG menu
HIGH LIGHT	34(E)	-	COLOR TEMP ADJ menu
I INPUT CONFIG	35(E)	[C]	INPUT CONFIG menu
INPUT NO	36(E)	-	INPUT CONFIG menu
L LAST	40(E)	-	SYSTEM CONFIG menu
LOAD REF VALUE	34(E)	[B21]	COLOR TEMP ADJ menu
LOW LIGHT	34(E)	-	COLOR TEMP ADJ menu

Menu Item	Page	Menu number	Main menu
M MAINTENANCE	40(E)	[E5]	SYSTEM CONFIG menu
MANUAL	32(E)	[A1]	CONTROL PRESET ADJ menu
	34(E)	[B1]	COLOR TEMP ADJ menu
MARKER PHASE	36(E)	-	INPUT CONFIG menu
MARKER WIDTH	36(E)	-	INPUT CONFIG menu
MODEL NAME	42(E)	-	STATUS menu
MONITOR ADDRESS	38(E)	-	REMOTE menu
	41(E)	[E11]	SYSTEM CONFIG menu
N NEW NAME	36(E)	-	INPUT CONFIG menu
NTSC, PAL	36(E)	-	INPUT CONFIG menu
NTSC SET UP	36(E)	-	INPUT CONFIG menu
P PARALLEL REMOTE	38(E)	-	REMOTE menu
PARALLEL REMOTE CONFIG	38(E)	[D2]	REMOTE menu
PHASE	32(E)	-	CONTROL PRESET ADJ menu
POSITION	41(E)	-	SYSTEM CONFIG menu
PROBE	34(E)	-	COLOR TEMP ADJ menu
PROG	36(E)	-	INPUT CONFIG menu
R REMOTE	37(E)	[D]	REMOTE menu
RGB	35(E)	-	INPUT CONFIG menu
R OFF	38(E)	[D211]	REMOTE menu
S SERIAL NO	42(E)	-	STATUS menu
SERIAL REMOTE	38(E)	[D1]	REMOTE menu
SLOT 1	42(E)	[F3]	STATUS menu
SLOT NO	36(E)	-	INPUT CONFIG menu
SMPTÉ COLOR BAR	32(E)	-	CONTROL PRESET ADJ menu
STANDBY MODE	40(E)	-	SYSTEM CONFIG menu
START	34(E)	-	COLOR TEMP ADJ menu
STATUS	42(E)	[F]	STATUS menu
STD	34(E)	-	COLOR TEMP ADJ menu
SYSTEM CONFIG	39(E)	[E]	SYSTEM CONFIG menu
V V CENTER	44(E)	-	ALIGNMENT menu
V SIZE	44(E)	-	ALIGNMENT menu
VTR	36(E)	-	INPUT CONFIG menu
X X	34(E)	-	COLOR TEMP ADJ menu
Y Y	34(E)	-	COLOR TEMP ADJ menu
YPBPR	36(E)	-	INPUT CONFIG menu
YPBPR MATRIX	36(E)	-	INPUT CONFIG menu
1 1125/60I SYSTEM	36(E)	-	INPUT CONFIG menu
1 PIN	38(E)	[D21]	REMOTE menu
2 2 PIN	38(E)	-	REMOTE menu
3 3 PIN	38(E)	-	REMOTE menu
4 4 PIN	38(E)	-	REMOTE menu
5 5 PIN	38(E)	-	REMOTE menu
6 6 PIN	38(E)	-	REMOTE menu
7 7 PIN	38(E)	-	REMOTE menu
8 8COLOR BAR 100%	32(E)	-	CONTROL PRESET ADJ menu
8COLOR BAR 75%	32(E)	-	CONTROL PRESET ADJ menu
8 PIN	38(E)	-	REMOTE menu

# Menu Configuration

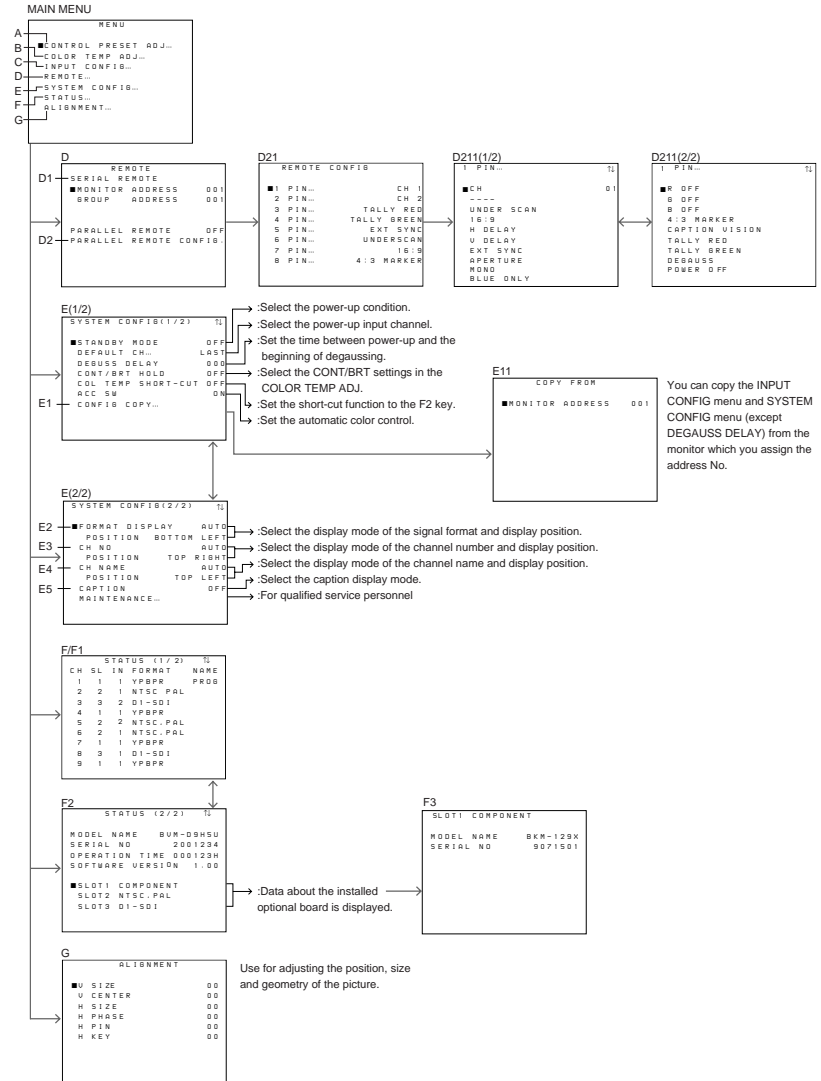
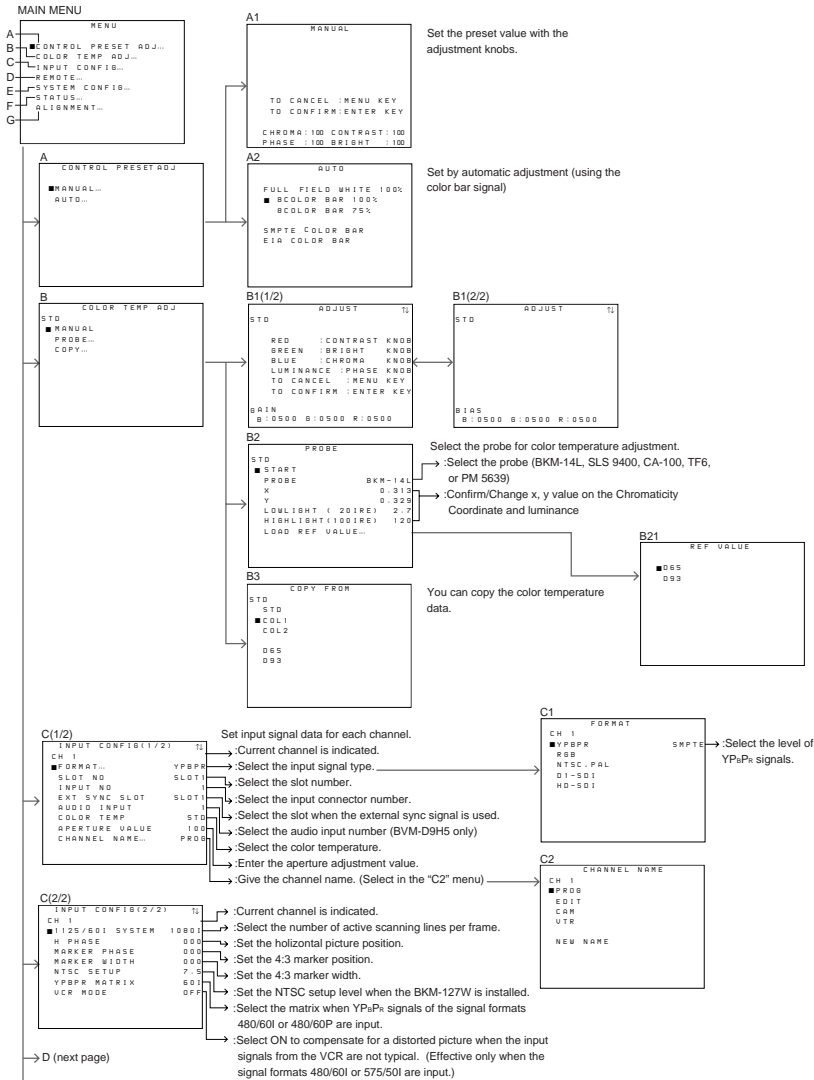

# Section 2

## Service Informations

### 2-1. Circuit Boards Location (1/2)

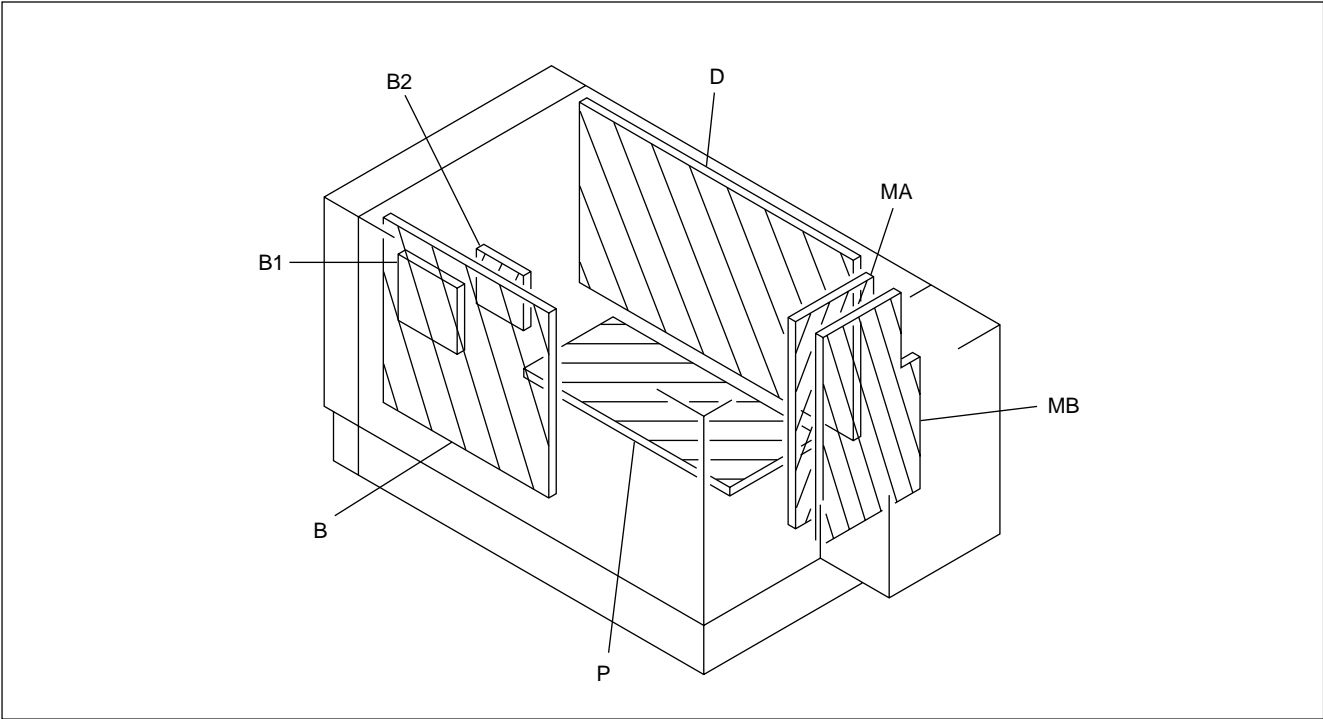

### 2-1. Circuit Boards Location (2/2)

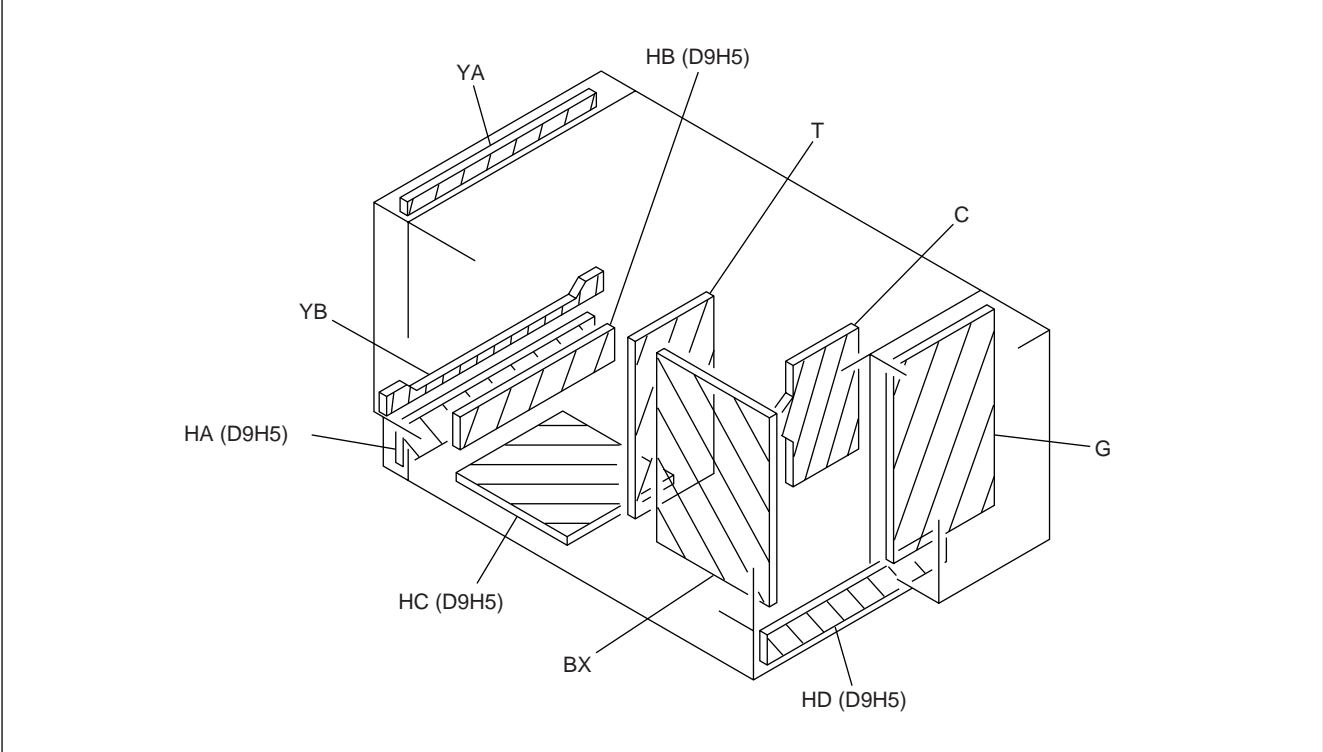

## 2-2-1. Cabinet Assy Removal

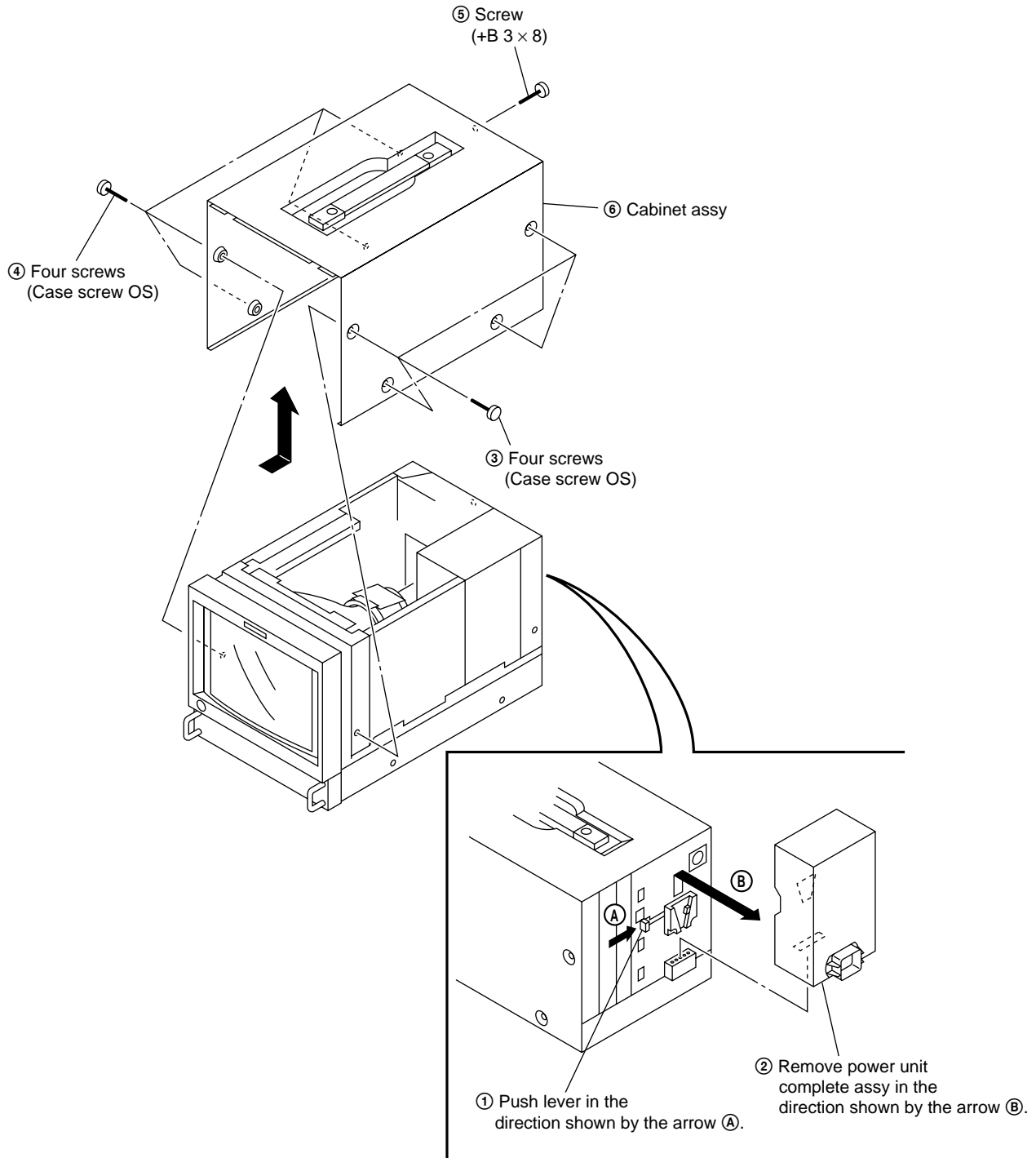



## 2-2-2. Control Panel Complete Assy Removal (D9H5)

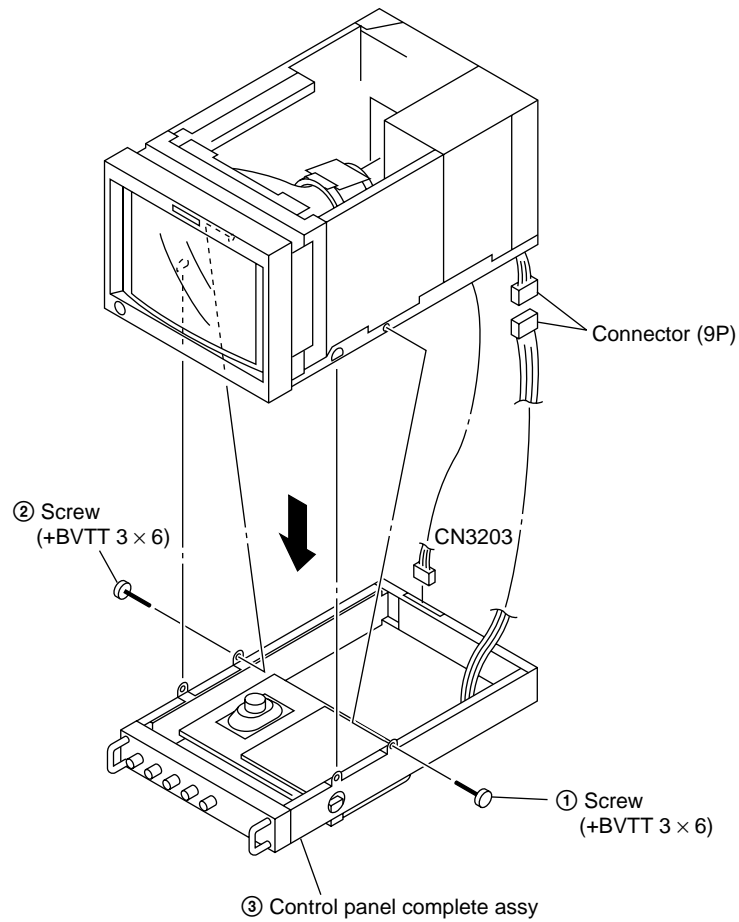

## 2-2-3. HA and HB Boards Removal (D9H5)

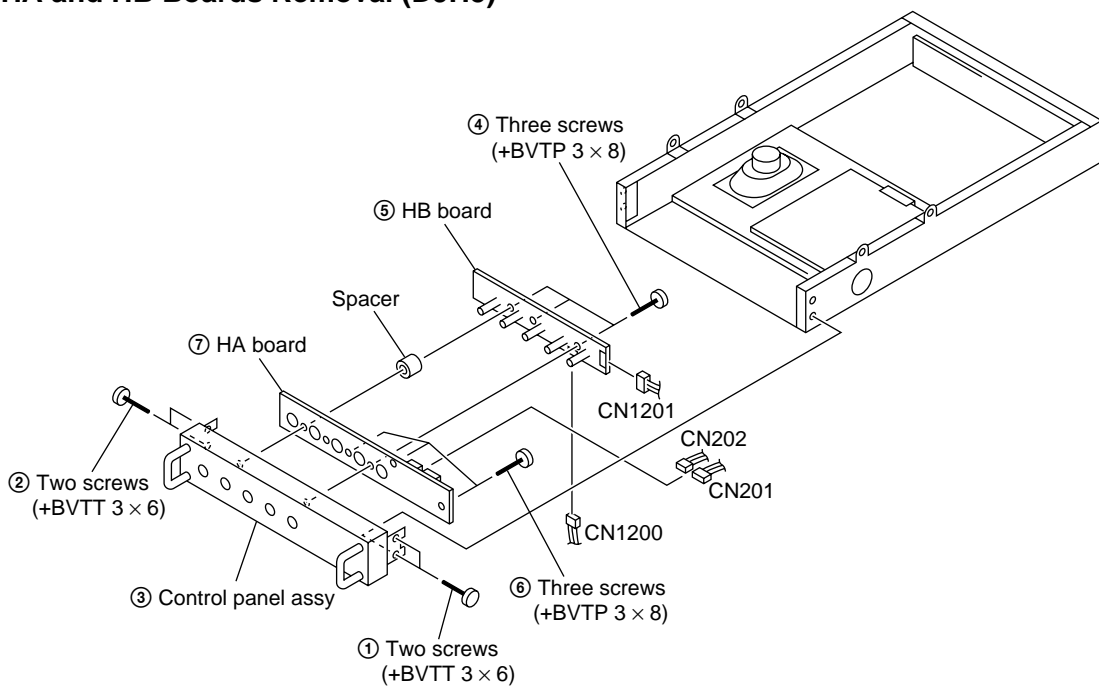

### 2-2-4. HC and HD Boards Removal (D9H5)

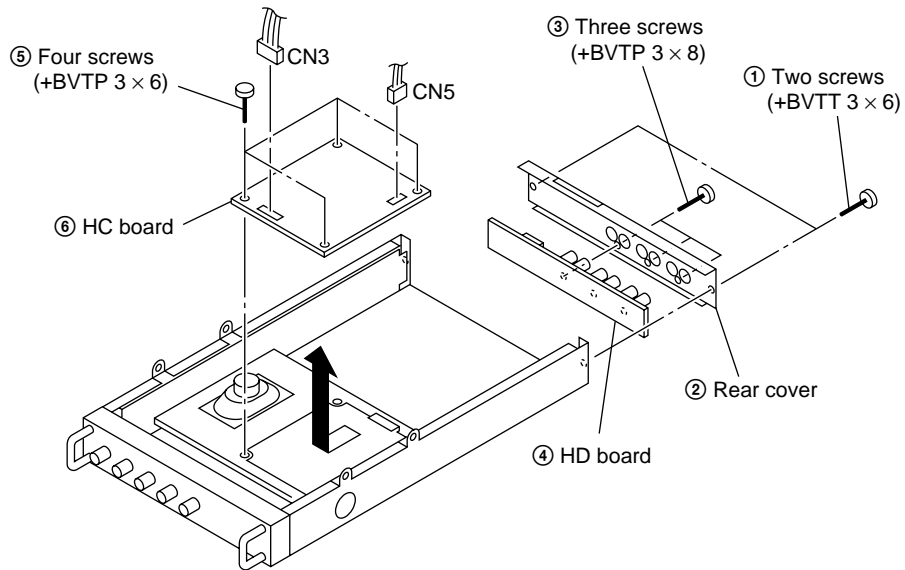

### 2-2-5. YA and YB Boards Removal

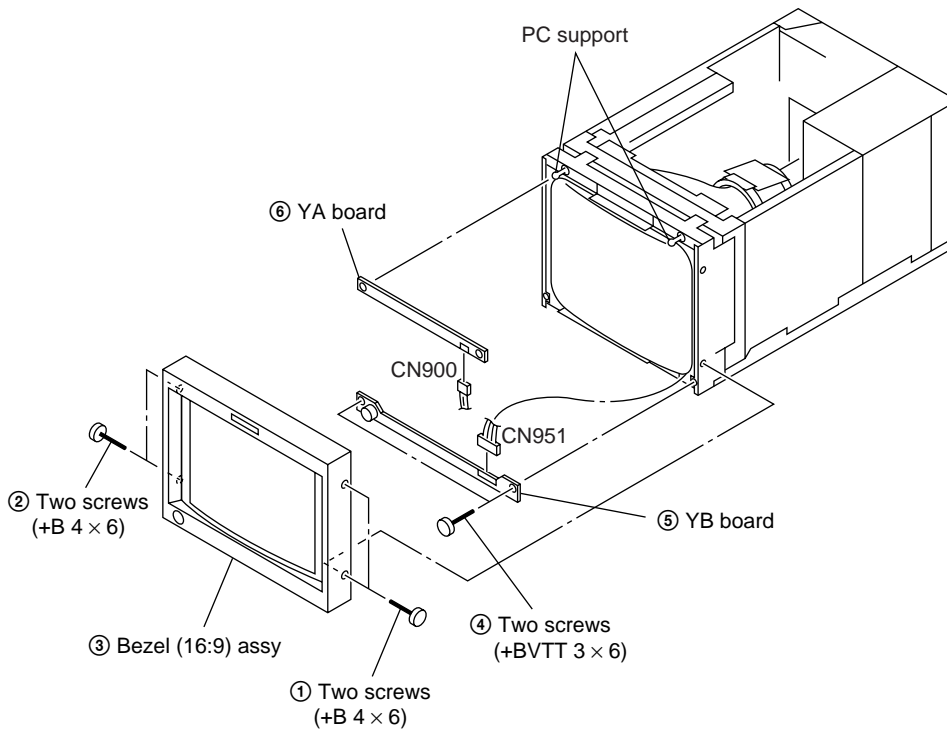

## 2-2-6. B, B1 and B2 Boards Removal

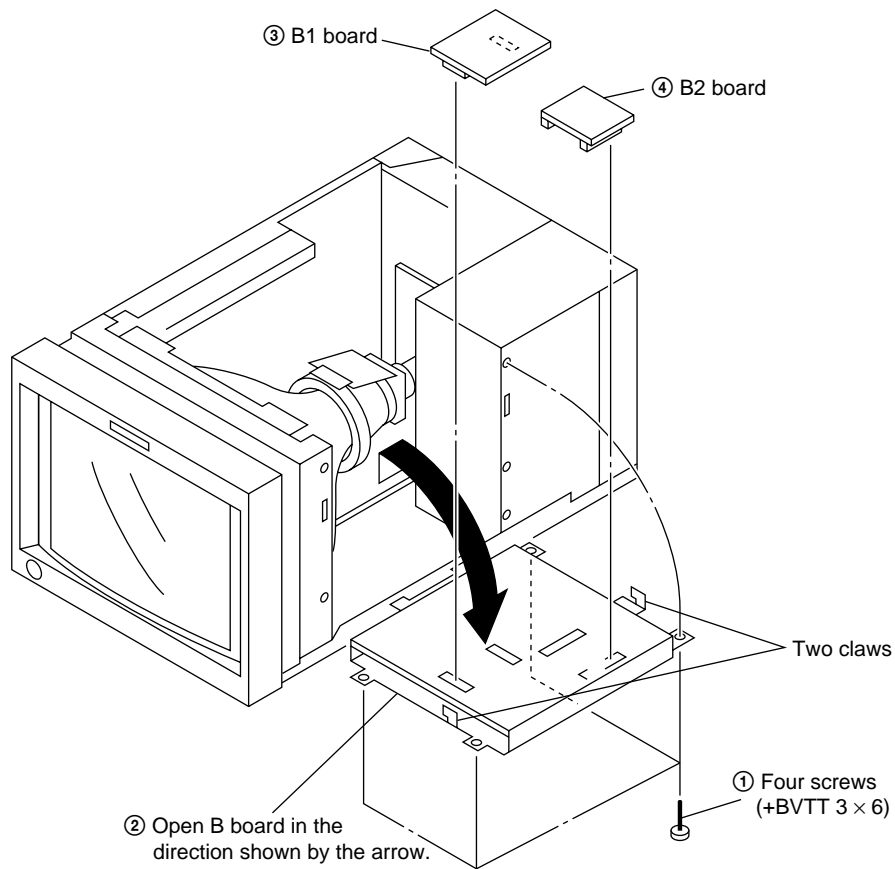

## 2-2-7. How to Open D Board

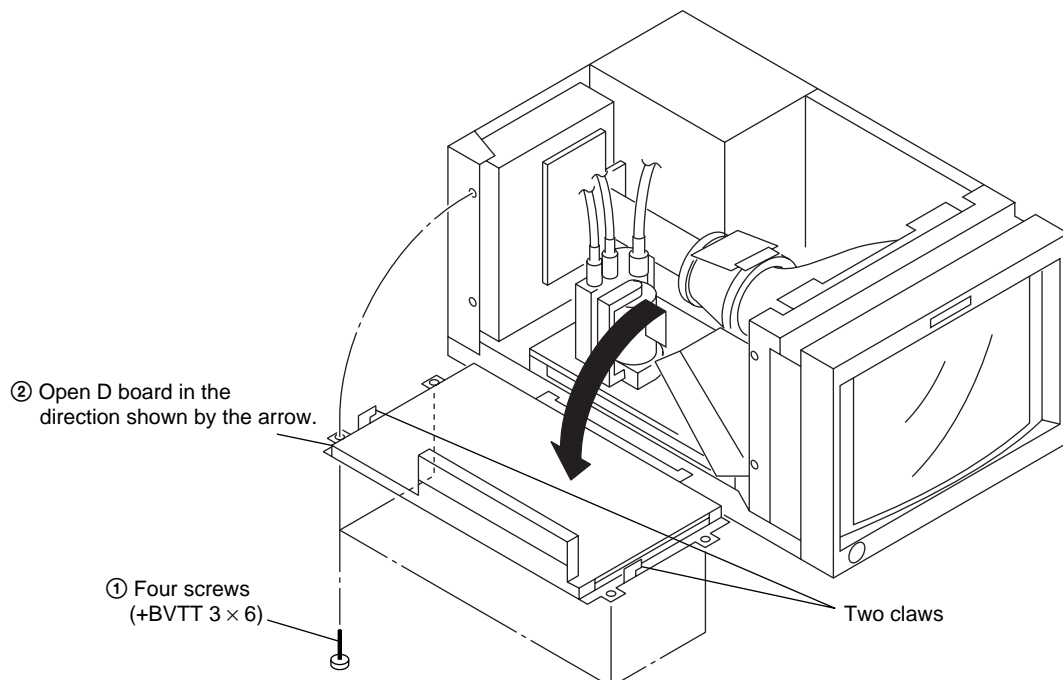

## 2-2-8. P Board Removal

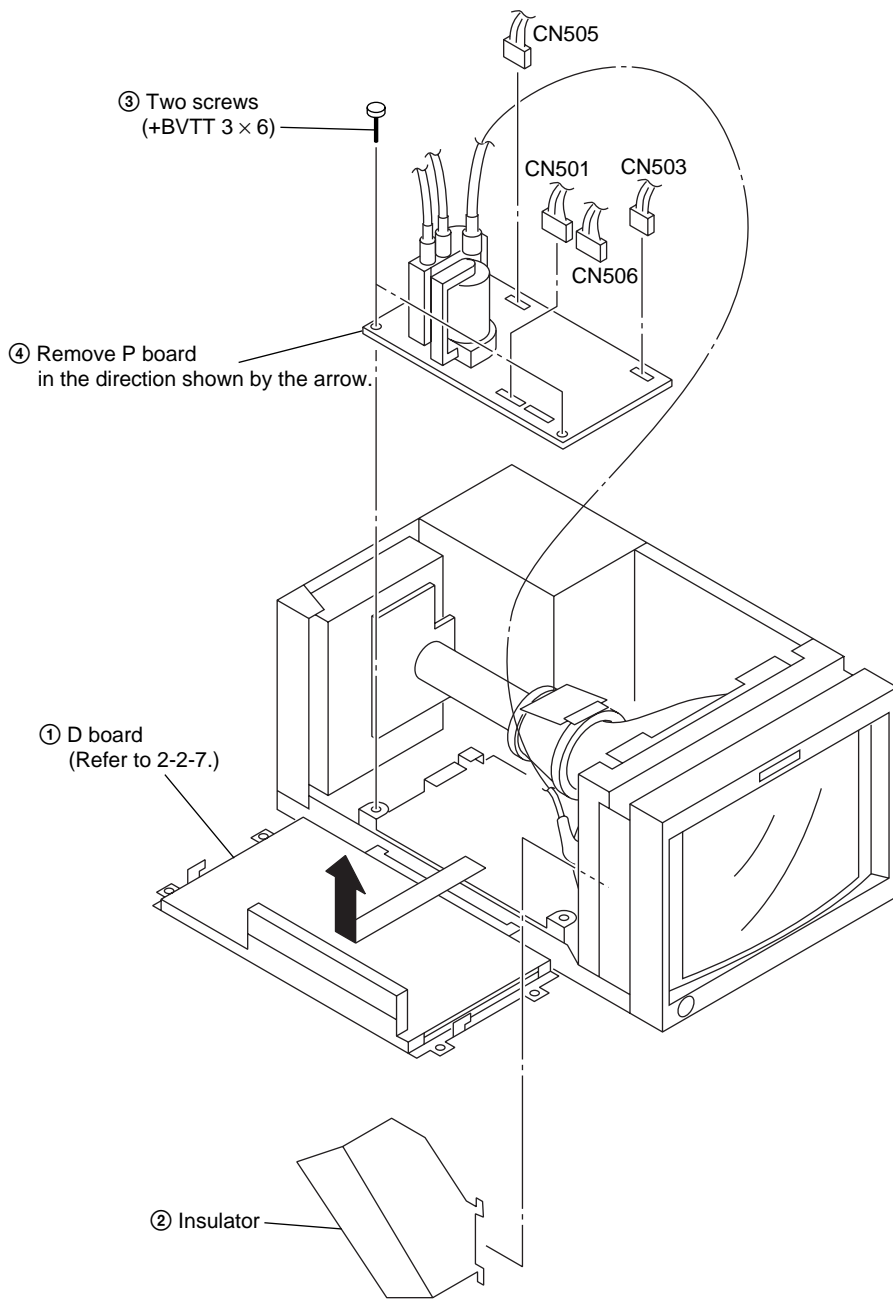

## 2-2-9. BX Board (BKM-129X) Removal and Check

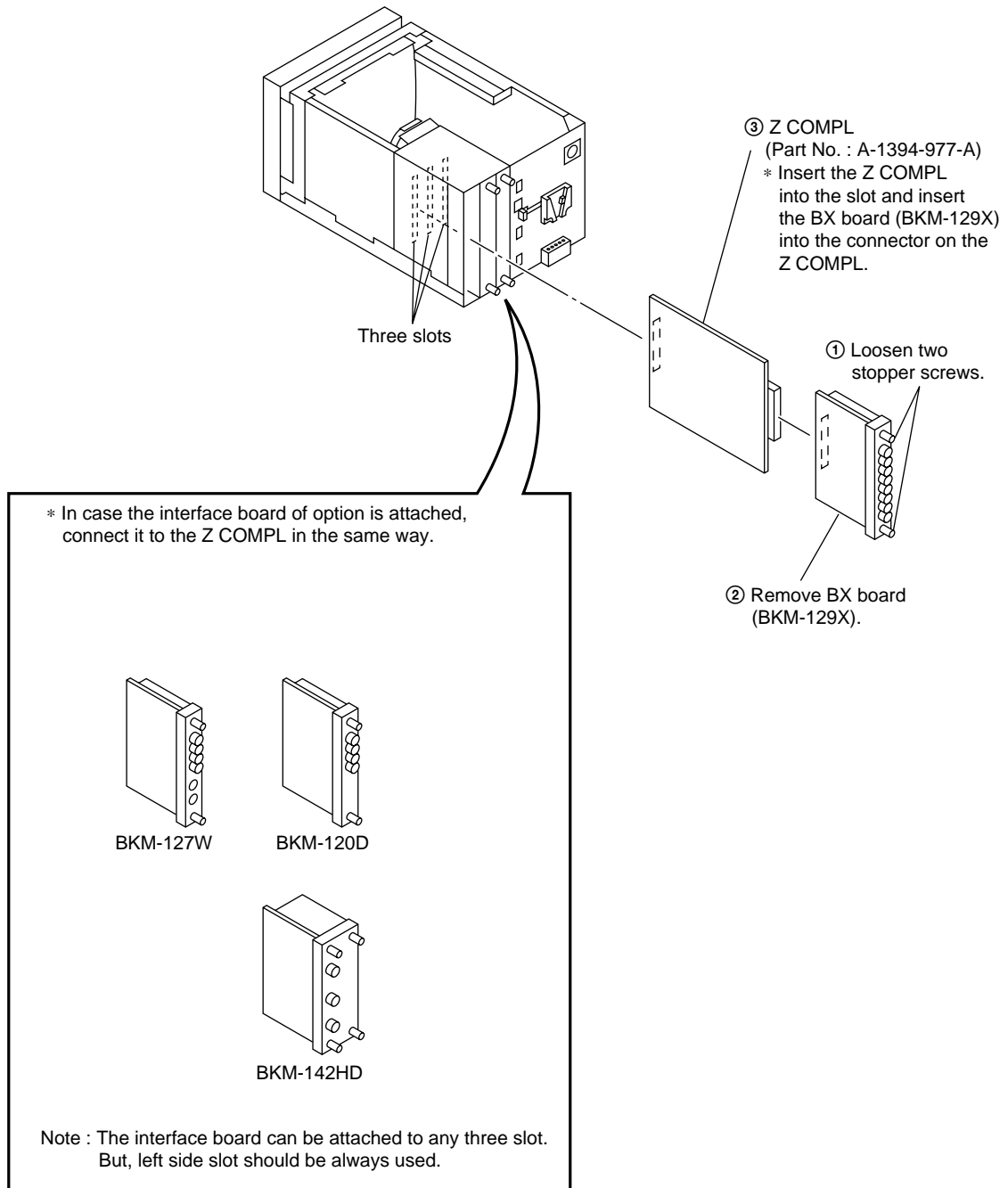

## 2-2-10. T Board Removal

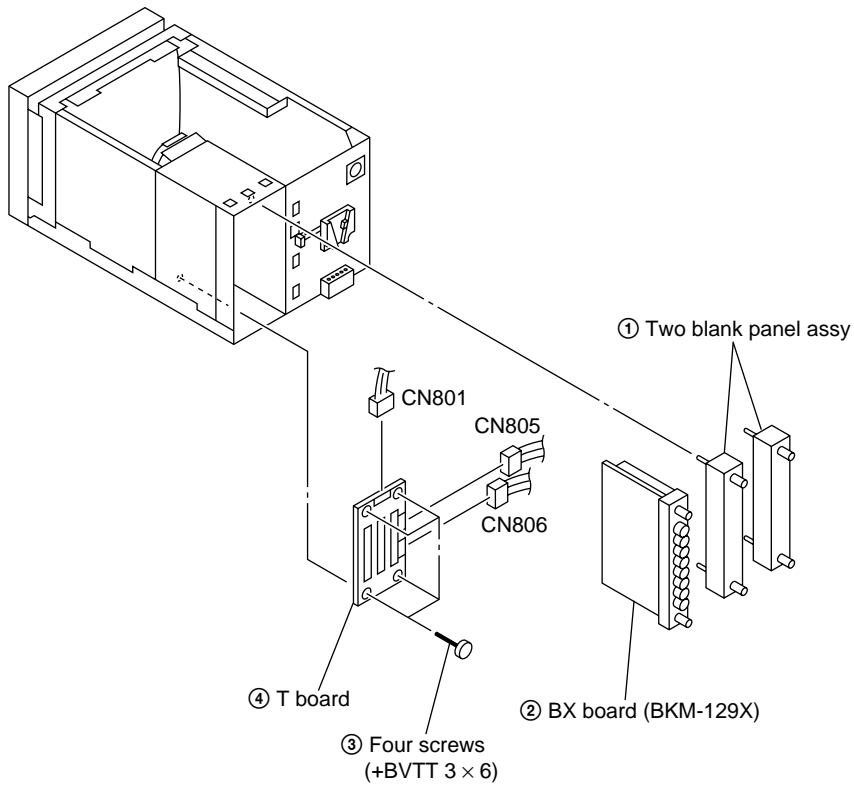

## 2-2-11. M Block Assy (MA and MB Boards) Removal

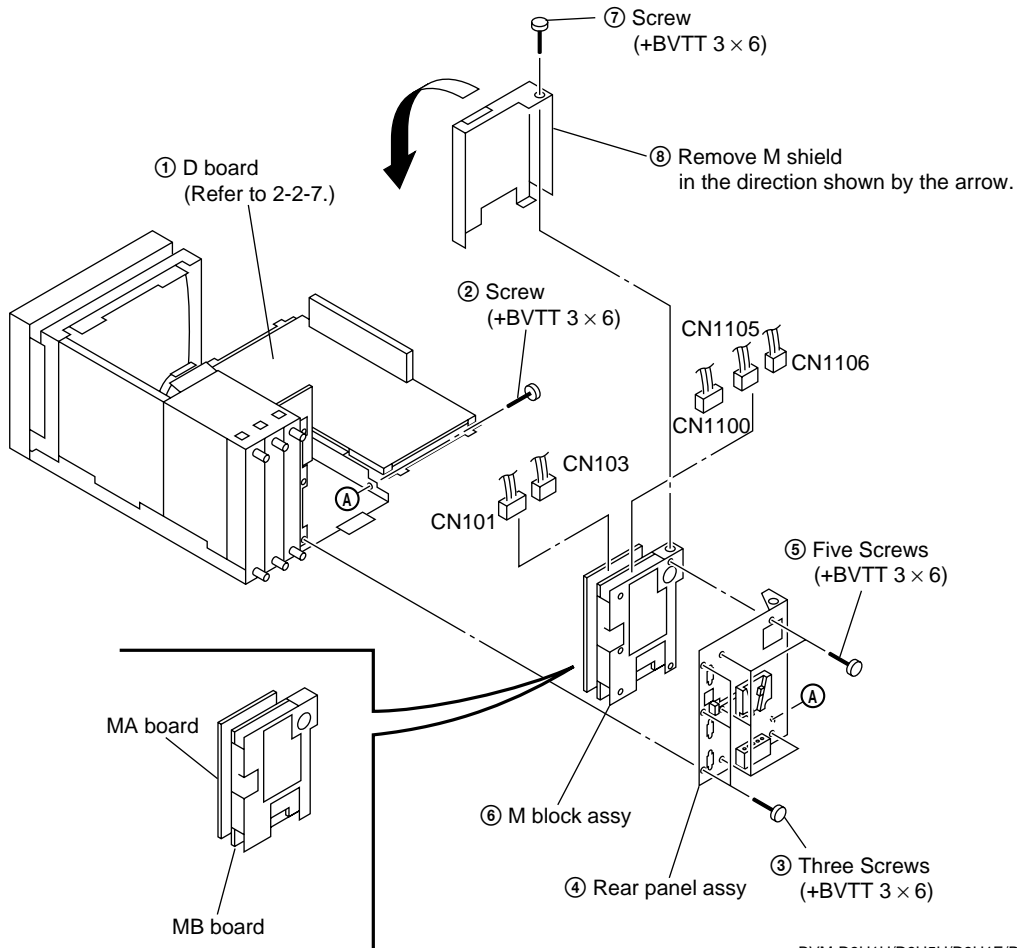

## 2-2-12. G Board Removal

\* Remove the power unit complete assy. (Refer to 2-2-1.)

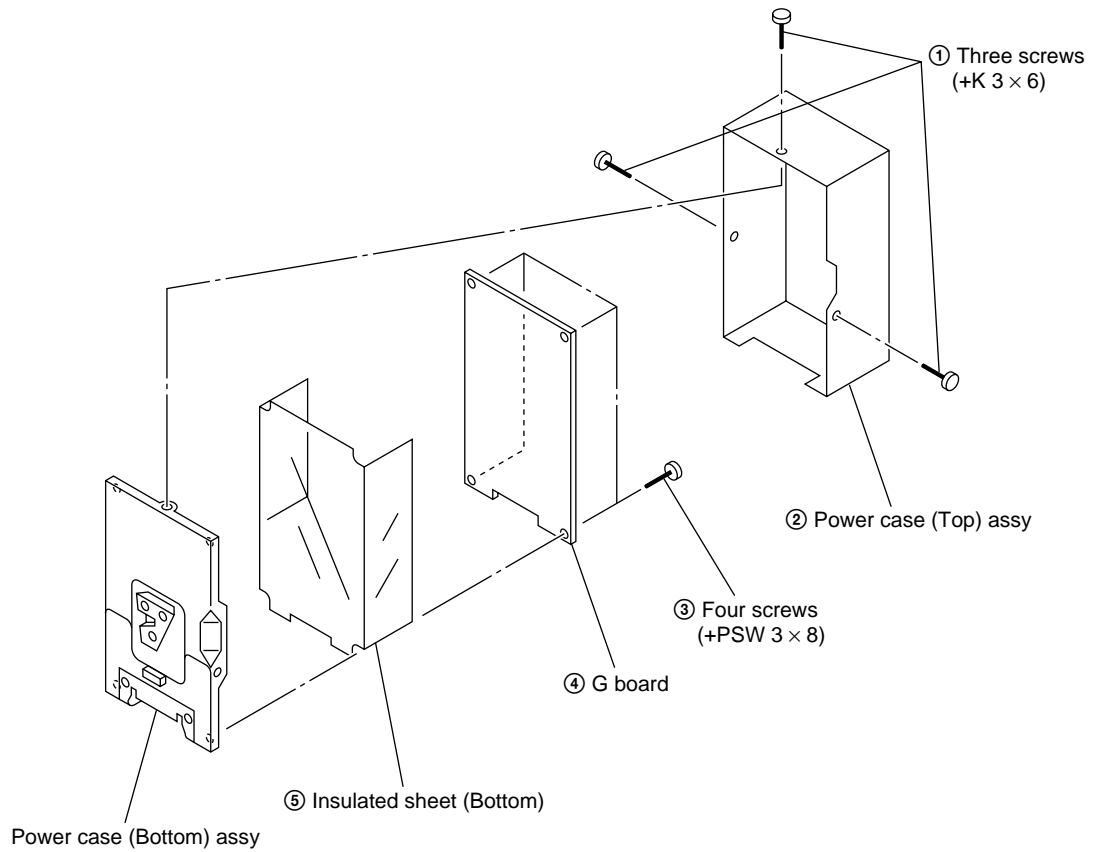

## 2-2-13. Picture Tube Removal

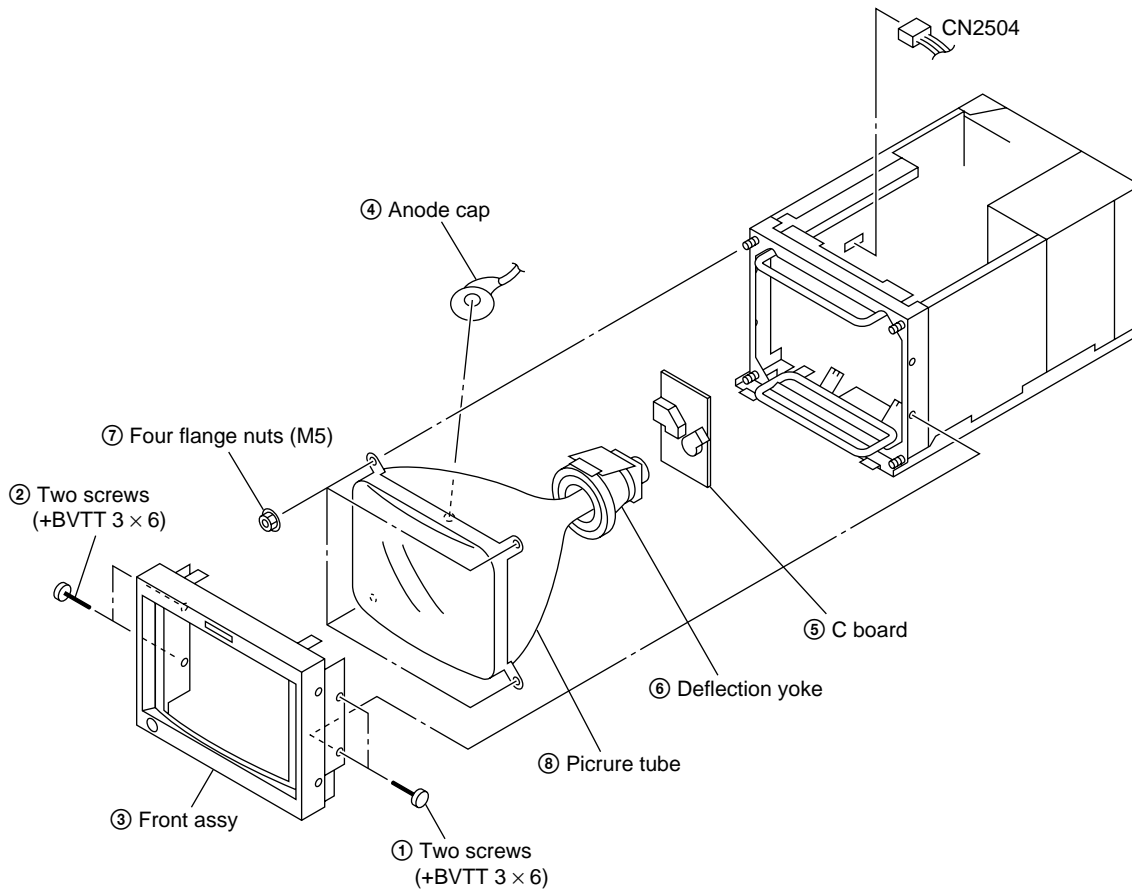

### • REMOVAL OF ANODE CAP

Note: To eliminate electric shock hazard, when replacing the picture tube, short-circuit the anode of the picture tube and the high-voltage terminal of anode cap to the picture tube shield or carbon painted on the picture tube, after removing the anode.

#### • Removal Procedure

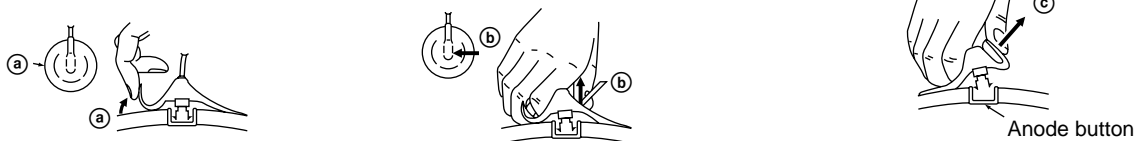

- (1) Turn up one side of the rubber cap in the direction indicated by arrow (a).
- (2) Using a thumb, pull up the rubber cap firmly in the direction indicated by arrow (b).
- (3) When one side of the rubber cap is separated from the anode button, the anode-cap can be removed by turning up the rubber cap and pulling up it in the direction of the arrow (c).

#### • Handling Precautions

- (1) Do not scratch the surface of anode cap with a sharp object.
- (2) Do not press the rubber so hard that it damages the inside of anode caps. A shatter-hook terminal is built into the rubber.
- (3) Do not turn the foot of the rubber over.  
The shatter-hook terminal will stick out or damage the rubber.

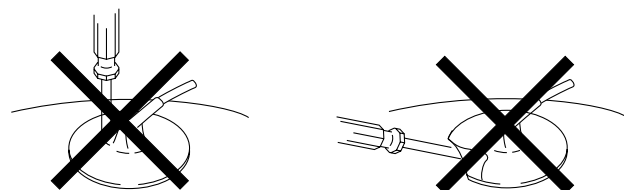



# Section 3

## Set-Up Adjustments

### 3-1. Set-Up Adjustment When CRT is Replaced

This section describes the adjustments to be performed when the CRT is replaced.

#### [Preparations]

- Required tools and measuring instruments

1. Signal generator
  - YPBYPR signal generator
    - 1080/60i (1125) : SMPTE274M standard/  
BTA S-001 standard
    - 1035/60i (1125) : BTA S-001 standard or  
SMPTE240M standard
    - 720/60p : SMPTE296M standard
    - 480/60p (525p) : BTA T-1004 standard or  
SMPTE293M standard
    - 480/60i (525) : ITU601
    - 1080/48i (1125) : —
    - 1080/50i (1125) : SMPTE274M standard
    - 720/50p : —
    - 575/50p (625p) : —
    - 575/50i (625) : ITU601
  - NTSC analog composite signal generator
  - HD SDI signal generator
  - D1 SDI signal generator
2. BKM-127W (NTSC/PAL input adapter)
3. BKM-142HD (HD SDI input adapter)
4. BKM-120D (D1 SDI input adapter)
5. Oscilloscope
6. Luminance meter
7. Color analyzer (Minolta CA-100)
8. Cable of the following specifications to connect the RS-232C terminal of the CA-100 and the OPTION terminal of the monitor.

- Setting the INPUT CONFIGURATION menu

Set the INPUT CONFIGURATION menu of the SETUP menu as shown below unless otherwise specified.

```

FORMAT ..... YPBPR
SLOT NO ..... 1
INPUT NO ..... 1
SYNC MODE ..... INT
APEARTURE VALUE ..... 100
CHANNEL NAME ..... PROG
COLOR TEMP ..... STD
H PHASE ..... 000
MARKER PHASE ..... 000
MARKER WIDTH ..... 000
  
```

- Operate the SYSTEM CONFIG menu as follows.

Use the SYSTEM menu to select ALL SYSTEM with the RE-LOAD FACTORY DATA, and execute it.

BVM-D9H1/D9H5  
control panel

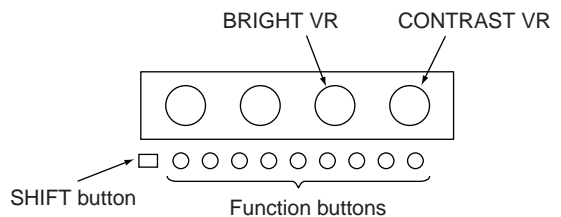

HDM option connector side

Mini DIN 8-pin

H SYNC	1
V SYNC	2
RTS	3
GND	4
NC	5
TXD	6
+5V	7
RXD	8

CA-100 RS-232C connector side

D Sub 25-pin (male)

1	FG
2	TXD
3	RXD
4	RTS
5	CTS
6	NC
7	GND
8	NC
9-19	NC
20	DTR
21-25	NC

• Connection diagram

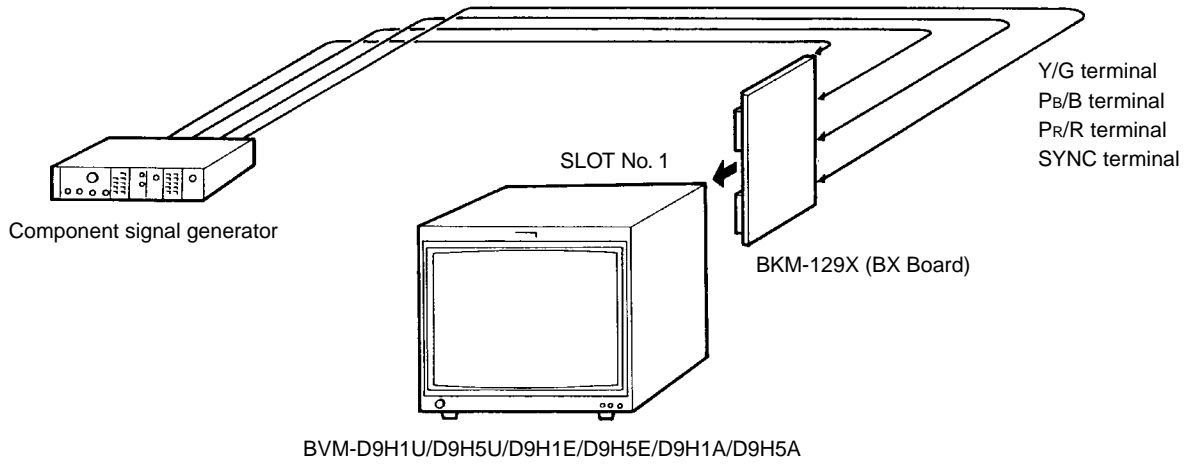

### [Focus Adjustment]

1. Connect the 1080/60i cross-hatch signal (see note) to the ANALOG Y/G input connector.

Note: This is the 1125 (1080) cross-hatch signal.

2. Set the initial (default) value to the following DF adjustment data.

FOCUS AMP : 00

FOCUS KEY : 07

Note: This menu is located in the directory under the DEFLECTION menu of the MAINTENANCE menu.

3. Obtain the optimum focus at the center of the screen by adjusting the FOCUS adjustment control.
4. Connect the 1080/60i monoscope signal to the ANALOG Y/G input connector.
5. Check that the horizontal resolution higher than the specifications can be recognized.

Specifications: 320 TV lines or more

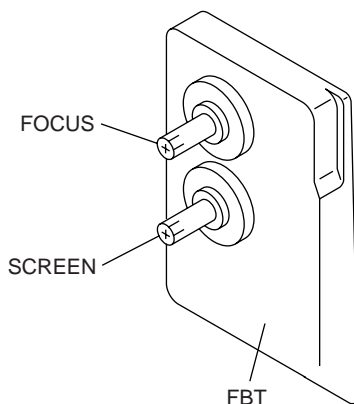

Fig. 1-1

### [Landing Adjustment]

1. Connect the 480/60i entire-white signal (see note) to the ANALOG Y/G input connector.

Note: This is the NTSC entire-white signal.

2. Press the SHIFT button to ON. [The LED (orange) on top of the button turns on.]
3. Press the 16:9 button to the OFF position to set the 4:3 mode. [The LED (orange) on top of the button turns off.]
4. Direct the CRT screen toward east (or west). Press the DEGAUSS button.
5. Set the Purity knob in the mechanical center.

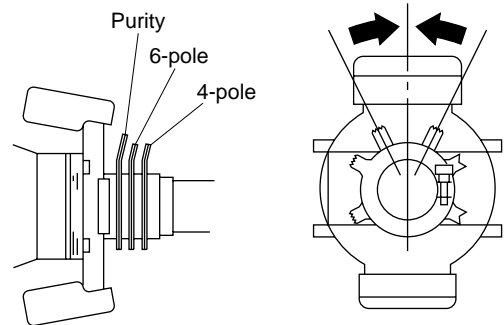

Fig. 1-2

6. Push the DY (deflection yoke) to the front as far as it can go.
7. Change the screen display to all green only as follows. [While the SFHIT is ON (the orange LED on the SHIFT button turns on), press the R and B button to ON. (The orange LED on the SHIFT button turns on.)]
8. Adjust the Purity knob until green comes to the center of the display.

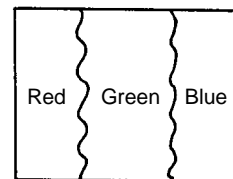

Fig. 1-3

9. Move back the DY so that the entire screen shows the green only.

10. Connect the 480/60i cross-hatch signal (see note) to the ANALOG Y/G input connector.  
Note: This is the NTSC cross-hatch signal.
11. Adjust the DY inclination. After DY inclination adjustment is complete, tighten the DY fixing screw.
12. Fix the deflection yoke (DY) using the three DY spacers.

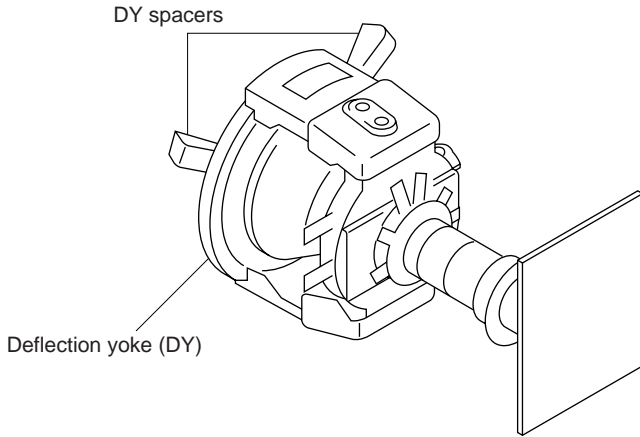

Fig. 1-4

• Final adjustment

When the adjustment is complete, check that mis-landing (landing error) does not occur even when the monitor is directed in all directions of east, west, south and north.

**[H. Blanking Adjustment]**

• Preparation

1. Connect the monoscope signal of the signal formats that are shown in the following table, to the ANALOG Y/G input connector. Perform the H. blanking adjustment in the respective screen modes using the respective signal formats.

60 Hz system

Mode	Signal format	Screen mode	
MODE1	1080/60i	16 : 9	NORMAL
MODE2	(1125)		UNDER SCAN
MODE3	1035/60i	16 : 9	NORMAL
MODE4	(1125)		UNDER SCAN
MODE5	720/60p	16 : 9	NORMAL
MODE6			UNDER SCAN
MODE7	480/60p	16 : 9	NORMAL
MODE8	(525)		UNDER SCAN
MODE9		4 : 3	NORMAL
MODE10			UNDER SCAN
MODE11	480/60i	16 : 9	NORMAL
MODE12	(525)		UNDER SCAN
MODE13		4 : 3	NORMAL
MODE14			UNDER SCAN



50 Hz system

Mode	Signal format	Screen mode	
MODE15	1080/48i	16 : 9	NORMAL
MODE16	(1125)		UNDER SCAN
MODE17	1080/50i	16 : 9	NORMAL
MODE18	(1125)		UNDER SCAN
MODE19	720/50p	16 : 9	NORMAL
MODE20			UNDER SCAN
MODE21	575/50P	16 : 9	NORMAL
MODE22	(625)		UNDER SCAN
MODE23		4 : 3	NORMAL
MODE24			UNDER SCAN
MODE25	575/50i	16 : 9	NORMAL
MODE26	(625)		UNDER SCAN
MODE27		4 : 3	NORMAL
MODE28			UNDER SCAN

2. Increase the brightness by adjusting the BRIGHT control so that blanking becomes visible on screen.  
Note: The following adjustment menus are located in the directory under the DEFLECTION menu of the MAINTENANCE menu.

H BLK LEFT    H CENT  
H BLK RIGHT    H PHASE  
H SIZE

• H. Blanking Adjustment

1. Press the SHIFT button to ON. [The LED (orange) on top of the button turns on.]
2. To select the 4:3 mode of the adjustment, press the 16:9 OFF button [to turn off the LED (orange)] to select the 4:3 mode.  
To select the 16:9 mode of the adjustment, press the 16:9 ON button [to turn on the LED (orange)] to select the 16:9 mode.
3. Press the SHIFT button to OFF. [The LED (orange) on top of the button turns off.]
4. To select the NORMAL mode of adjustment, press the UNDER SCAN button (  ) to its OFF position to select the normal mode. [The green LED turns off.]  
To select the UNDER SCAN mode of adjustment, press the UNDER SCAN button (  ) to its ON position to select the under scan mode. [The green LED turns on.]
5. Set the following data to maximum.  
H BLK LEFT : 255  
H BLK RIGHT : 255
6. Adjust the H. SIZE data so that the entire raster area is visible on screen.
7. Adjust the H. CENTER data so that the raster is position just in the center of the screen (so that  $A \cong B$ ). (Fig. 1-5)

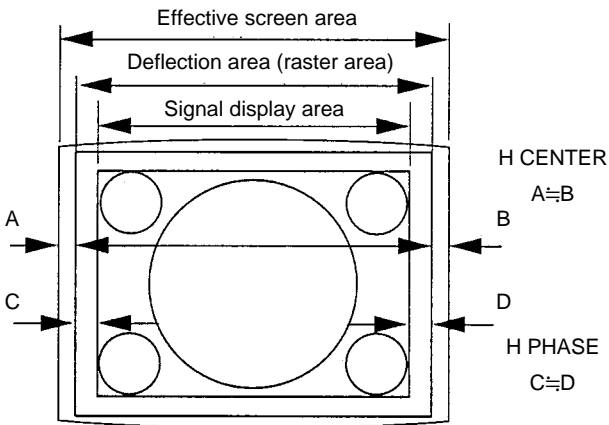

Fig. 1-5

8. Adjust the H. PHASE data so that the monoscope picture is position just in the center of the raster (so that  $C \cong D$ ).
9. Adjust the H. BLK. RIGHT data so that the horizontal blanking is position 0 to 2 mm outside the right end of the monoscope signal display area. (Fig. 1-6)
10. Adjust the H. BLK. LEFT data so that the horizontal blanking is position 0 to 2 mm outside the left end of the monoscope signal display area. (Fig. 1-6)
11. Return the H. SIZE data to the original data size.

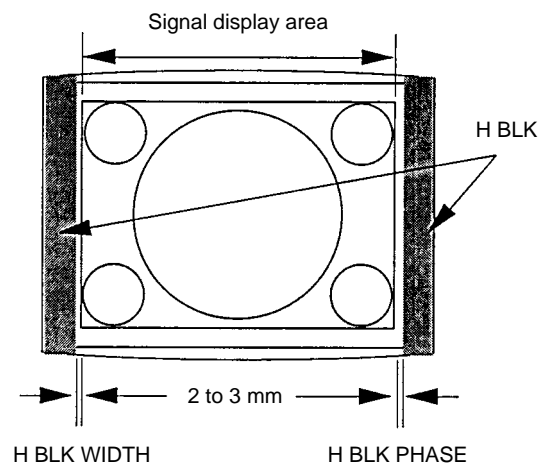

Fig. 1-6

## [V. Blanking Adjustment]

### • Preparation

1. Connect the monoscope signal of the signal formats that are shown in the following table, to the ANALOG Y/G input connector. Perform the V. blanking adjustment in the respective screen modes using the respective signal formats.

#### 60 Hz system

Mode	Signal format	Screen mode	
MODE9	480/60p (525)	4 : 3	NORMAL
MODE13	480/60i (525)	4 : 3	NORMAL

#### 50 Hz system

Mode	Signal format	Screen mode	
MODE23	575/50p(625)	4 : 3	NORMAL
MODE27	575/50i(625)	4 : 3	NORMAL

2. Increase the brightness by adjusting the BRIGHT control so that blanking becomes visible on screen.  
Note: The following adjustment menus are located in the directory under the DEFLECTION menu of the MAINTENANCE menu.

V BLK TOP

V SIZE

V CENT

### • V. Blanking Adjustment

1. Press the SHIFT button to ON. [The LED (orange) on top of the button turns on.]
2. Press the 16:9 OFF button [to turn off the LED (orange)] to select the 4:3 mode.
3. Press the SHIFT button to set the SHIFT OFF. [The LED (orange) on top of the button turns off.]
4. Press the UNDER SCAN button (  ) to its OFF position to select the normal mode. [The green LED turns off.]
5. Adjust the V. SIZE data so that the 5% over-scan is obtained.
6. Take note of the present V. CENT data. After noting, adjust the V. CENT data so that the top of the raster becomes visible.
7. Adjust the V. BLK. TOP data so that the vertical blanking on top of the screen is positioned as closest as possible to the signal display area.
8. Return the V. CENT data to the original data.

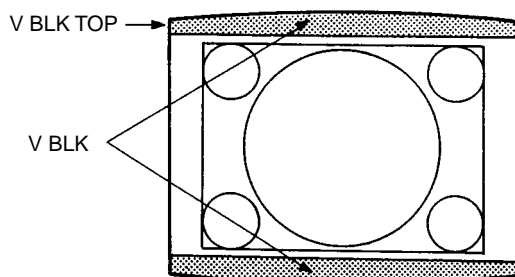

## [Linearity Adjustment]

### • Linearity Adjustment (1)

1. Connect the 1080/60i (1125) cross-hatch signal to the ANALOG Y/G input connector.
2. Press the SHIFT button to ON. [The LED (orange) on top of the button turns on.]
3. Press the 16:9 ON button [to turn on the LED (orange)] to select the 16:9 mode.
4. Press the SHIFT button to OFF. [The LED (orange) on top of the button turns off.]
5. Press the UNDER SCAN button (  ) to its OFF position to select the normal mode. [The green LED turns off.]
6. Check that the picture is not slanted, that there are no top and bottom PIN distortion and horizontal trapezoidal distortion.

Slanted picture :

Adjust inclination of the DY.

Horizontal PIN distortion :

Adjust upper and lower neck twist of the DY.

• Linearity Adjustment (2)

Note 1) Connect the monoscope signal or the cross-hatch signal having the following signal formats as shown in the table below, to the ANALOG Y/G input connector. Perform the linearity adjustment (2) in the respective screen modes using the respective signal formats.

60 Hz system

MODE	Signal format	Screen mode	
MODE1	1080/60i (1125)	16 : 9	NORMAL
MODE2			UNDER SCAN
MODE3	1035/60i (1125)	16 : 9	NORMAL
MODE4			UNDER SCAN
MODE5	720/60p	16 : 9	NORMAL
MODE6			UNDER SCAN
MODE7	480/60p (525)	16 : 9	NORMAL
MODE8			UNDER SCAN
MODE9		4 : 3	NORMAL
MODE10			UNDER SCAN
MODE11	480/60i (525)	16 : 9	NORMAL
MODE12			UNDER SCAN
MODE13		4 : 3	NORMAL
MODE14			UNDER SCAN

50 Hz system

MODE	Signal format	Screen mode	
MODE15	1080/48i (1125)	16 : 9	NORMAL
MODE16			UNDER SCAN
MODE17	1080/50i (1125)	16 : 9	NORMAL
MODE18			UNDER SCAN
MODE19	720/50p	16 : 9	NORMAL
MODE20			UNDER SCAN
MODE21	575/50P (625)	16 : 9	NORMAL
MODE22			UNDER SCAN
MODE23		4 : 3	NORMAL
MODE24			UNDER SCAN
MODE25	575/50i (625)	16 : 9	NORMAL
MODE26			UNDER SCAN
MODE27		4 : 3	NORMAL
MODE28			UNDER SCAN

Note 2) The following adjustment menus are located in the directory under the DEFLECTION menu of the MAINTENANCE menu.

- H SIZE
- H CENTER
- H KEY BAL
- H KEY
- H PIN BAL
- H PIN
- H COR S
- H COR PIN
- H PIN
- V SIZE
- V CENTER
- V LIN AMP
- V LIN BAL

1. Connect the monoscope signal to the ANALOG Y/G input connector.
  2. Press the SHIFT button to ON. [The LED (orange) on top of the button turns on.]
  3. To adjust the 4:3 mode of adjustment, press the 16:9 OFF button [to turn off the LED (orange)] to select the 4:3 mode.
  4. Press the SHIFT button to OFF. [The LED (orange) on top of the button turns off.]
  5. To select the NORMAL mode of adjustment, press the UNDER SCAN button (  ) to its OFF position to select the normal mode. [The green LED turns off.] To select the UNDER SCAN mode of adjustment, press the UNDER SCAN button (  ) to its ON position to select the under scan mode. [The green LED turns on.]
  6. Adjust the H CENTER data so that the horizontal center of the picture comes to the horizontal center of the screen.
  7. Adjust the V CENTER data so that the vertical center of the picture comes to the vertical center of the screen.
  8. Connect the cross-hatch signal to the ANALOG Y/G input connector.
  9. Adjust the respective V SIZE, V LIN BAL, V LIN AMP and H SIZE data so that the optimum picture is obtained as shown in Fig. 1-8.
- Note: Do not adjust the V SIZE data when adjusting the MODEs 9, 13, 23 and 27.
10. Adjust the trapezoidal distortion and PIN distortion on both sides of picture using the H KEY BAL, H KEY, H PIN BAL and H PIN data respectively as shown in Fig. 1-9.
  11. Adjust the corner "S" distortion and the corner PIN distortion on both sides of picture using the H CORS and H COR PIN data respectively as shown in Fig. 1-10.
  12. Repeat the above-described steps of the linearity adjustment(2) until the optimum horizontal linearity and vertical linearity are obtained.

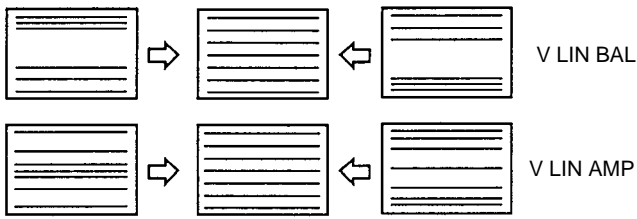

Fig. 1-8

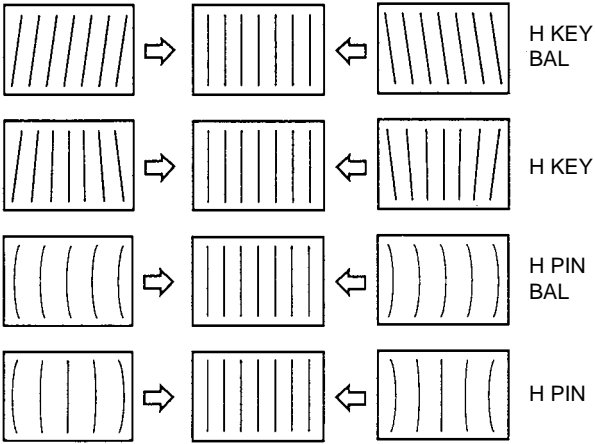

Fig. 1-9

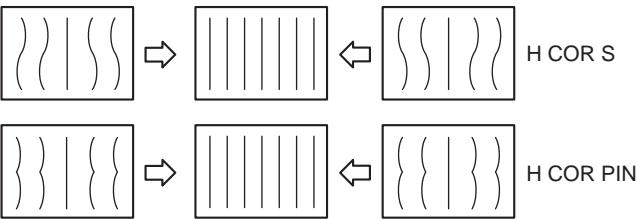



Fig. 1-10

**[Convergence Adjustment]**

• Preparation

1. Connect the 480/60p cross-hatch signal to the ANALOG Y/G input connector.
2. Press the SHIFT button to ON. [The LED (orange) on top of the button turns on.]
3. Press the 16:9 OFF button [to turn off the LED (orange)] to select the 4:3 mode.
4. Press the SHIFT button to OFF. [The LED (orange) on top of the button turns off.]
5. Press the UNDER SCAN button (  ) to its OFF position to select the NORMAL mode. [The green LED turns off.]

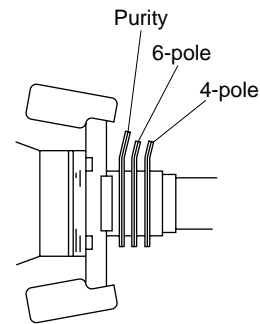

Fig. 1-11



**[Static Convergence Adjustment]**

- Horizontal Static Convergence Adjustment
- 1. Adjust RV701 on the C board so that the red dots and the green dots are correctly converged.
- 2. When the blue dot is mis-converged with respect to the red and green dots, implement the HMC (horizontal misconvergence) correction by adjusting the 4-pole magnet and the 6-pole magnet of the DY.

- Vertical Static Convergence Adjustment
- 1. Implement the VMC (vertical misconvergence) correction by adjusting the 4-pole magnet and the 6-pole magnet of the DY.

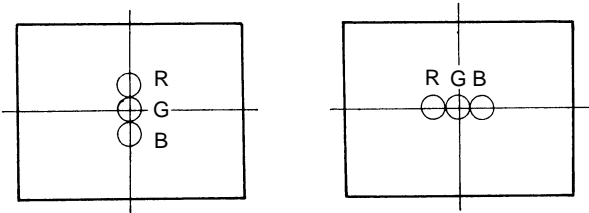

Fig. 1-12

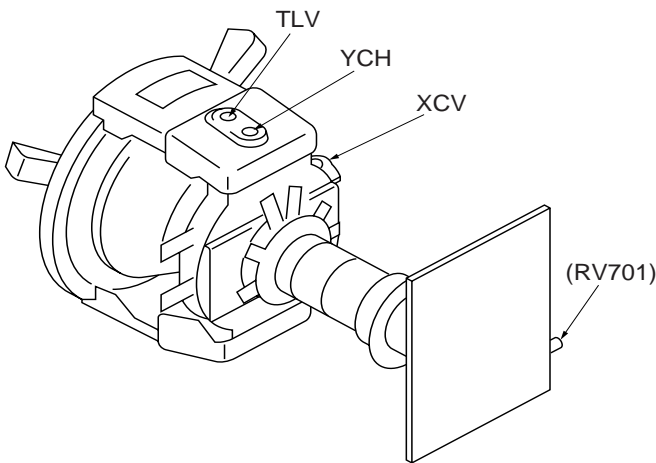

Fig. 1-13

**[Dynamic Convergence Adjustment]**

1. Minimize the vertical misconvergence in the left-most end of the center of a screen and in the right-most end of the center of a screen by the DY correction reactor XCV as shown in Fig. 1-14.
2. Minimize the vertical misconvergence in the top of a screen and in the bottom of a screen by the DY correction reactor TLV as shown in Fig. 1-14.

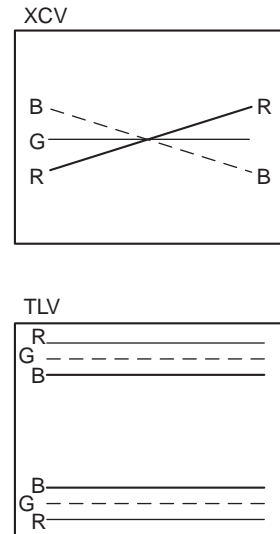

Fig. 1-14

**[G2 Adjustment]**

1. Turn off the POWER switch.
2. Disconnect the connector CN701 from the C board.
3. Apply the following DC voltage to pin-1, pin-3 and pin-5 of CN701 on the C board respectively.  
100 ± 2 V
4. Turn on the POWER switch.
5. Adjust the SCREEN control of FBT to the point of immediately before the blanking lines disappear on screen.
6. Turn off the POWER switch.
7. Remove the DC voltages that are applied in step 3, from the C board
8. Re-connect the connector CN701 to the C board.

**[White Balance Adjustment]**

1. Outline of the white balance adjustment and calibration of the color analyzer that is used for the white balance adjustment are described first.
  - 1.1 The parameter that converts the RGB drive voltage of a CRT to the chromaticity coordinate is acquired.

This monitor has the copy function of the color temperature data between two or more monitors.

However, the CRT drive voltage are unique in every monitor because it is different depending on each CRT. Therefore, the same color temperature cannot be obtained in multiple monitors even though the same drive voltage is given to them. It means that the data that is used to copy the color temperature, must be the xyY chromaticity coordinate or similar data that does not depend on each CRT, unlike the CRT drive that depends on each CRT.

When the D93 MANUAL adjustment is implemented using the MAINTENANCE/SYSTEM/COLOR TEMP menu of the SYSTEM CONFIG menu, the parameter that converts the CRT drive voltage to the chromaticity coordinate is created while the adjustment is implemented. This parameter is used when copying the color temperature data to other monitors as shown.

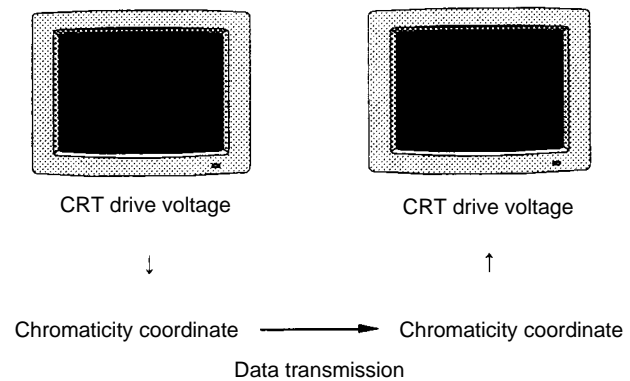

**Fig. 1-15**

1.2 D65 color temperature adjustment

1.3 Copying the color temperature data to the STD color temperature, COLOR1 color temperature and COLOR2 color temperature.

- On calibration of the color analyzer

When color temperature of any monitor is measured by two or more color analyzers, these color analyzers show different measurement values even though the object of measurement is the same. Also the measurement value of color analyzer changes as time elapses.

Therefore, any color analyzer must be calibrated so that it shows the correct measurement value of the following chromaticity coordinate before using the analyzer.

	x	y	y (cd/m <sup>2</sup> )
D65	0.313	0.329	2.7
	0.313	0.329	120
D93	0.283	0.297	2.7
	0.283	0.297	120

## 2. Preparation for Adjustment

- 2.1 Connect the 480/60i (525) WINDOW signal to the ANALOG Y/G input connector.
- 2.2 Connect the RS-232C connector of a color analyzer CA-100 with the OPTION connector of a monitor using the cable that is shown by section “3-1. Set-Up Adjustment When CRT is Replaced - Required tools and measuring instruments, item 8”.
- 2.3 Set up the CA-100 as described below. Attach the measurement probe of the CA-100 to the center of the CRT screen.

Display mode	xyY mode
Baud rate	9600

## 3. White Balance Adjustment





### 3.1 White Balance Adjustment (1)

1. Press the SHIFT ON button [to turn on the LED (orange) on top of the SHIFT button]. Press the 16:9 ON button [to turn on the LED (orange)] to select the 16:9 mode.
2. Press the MONO ON button to select the B/W mode. [The green LED turns on.]
3. Select MAINTENANCE menu of the SYSTEM CONFIG menu.
4. Select VIDEO menu of the MAINTENANCE menu.
5. Take note of the SUB CONTRAST data. Then set 100 to the SUB CONTRAST data.
6. Select SYSTEM/COLOR TEMP menu of the MAINTENANCE menu.
7. Select D93 of the SYSTEM/COLOR TEMP menu. Then cover the entire CRT screen surface with a black blind cloth. Select the MANUAL adjustment item and adjust the white balance until the following value is obtained.  
 $x = 0.283$   
 $y = 0.297$
8. Select D65 of the SYSTEM/COLOR TEMP menu. Then cover the entire CRT screen surface with a black blind cloth. Select the MANUAL adjustment item and adjust the white balance until the following value is obtained.  
 $x = 0.313$   
 $y = 0.329$
9. Select the SYSTEM/COLOR TEMP/COPY/OTHER VALUE menu.
10. After selecting the STD item of the COLOR TEMP menu, select D93. Copy the D93 color temperature data to STD.

11. After selecting the COLOR1 item of the COLOR TEMP menu, select D65. Copy the D65 color temperature data to COLOR1.
12. After selecting the COLOR2 item of the COLOR TEMP menu, select D93. Copy the D93 color temperature data to COLOR2.
13. Select VIDEO menu of the MAINTENANCE menu.
14. Return the SUB CONTRAST data to the original data.
15. Press the MONO button to the OFF position to cancel the B/W mode. [The green LED turns off.]

### 3.2 Sub Contrast Adjustment

1. Connect the 480/60i (525) WINDOW signal to the ANALOG Y/G input connector.
2. Attach the luminance meter to the center of the CRT screen.
3. Select STD using the COLOR TEMP menu of the INPUT CONFIG menu.
4. Select MAINTENANCE menu of the SYSTEM CONFIG menu.
5. Select SUB CONTRAST menu of the VIDEO menu.
6. Press the SHIFT ON button [to turn on the LED (orange) on top of the SHIFT button]. Press the 16:9 OFF button [to turn off the LED (orange)] to select the 4:3 mode.
7. Press the SHIFT OFF button [to turn off the LED (orange) on top of the SHIFT button]. Press the UNDER SCAN button (  ) to its ON position to select the under scan mode. [The green LED turns on.]
8. Adjust SUB CONTRAST so that luminance becomes 120 cd/m<sup>2</sup>.
9. Press the SHIFT ON button [to turn on the LED (orange) on top of the SHIFT button]. Press the 16:9 ON button [to turn on the LED (orange)] to select the 16:9 mode.
10. Adjust SUB CONTRAST so that luminance becomes 120 cd/m<sup>2</sup>.
11. Press the SHIFT OFF button [to turn off the LED (orange) on top of the SHIFT button]. Press the UNDER SCAN button (  ) to its ON position to select the under scan mode. [The green LED turns on.]
12. Adjust SUB CONTRAST so that luminance becomes 120 cd/m<sup>2</sup>.
13. Press the UNDER SCAN button (  ) to its ON position to select the under scan mode. [The green LED turns on.]
14. Press the SHIFT ON button [to turn on the LED (orange) on top of the SHIFT button]. Press the 16:9 OFF button [to turn off the LED (orange)] to select the 4:3 mode.

15. Connect the 1080/60i 100 IRE WINDOW signal to the ANALOG Y/G input connector.
16. Adjust SUB CONTRAST so that luminance becomes 120 cd/m<sup>2</sup>.
17. Press the SHIFT OFF button [to turn off the LED (orange) on top of the SHIFT button].  
Press the UNDER SCAN button (  ) to its ON position to select the under scan mode. [The green LED turns on.]
18. Adjust SUB CONTRAST so that luminance becomes 120 cd/m<sup>2</sup>.
19. Press the UNDER SCAN button (  ) to its OFF position to select the normal mode. [The green LED turns off.]
20. Connect the 480/60p (525P) 100IRE WINDOW signal to the to ANALOG Y/G input connector.
21. Press the SHIFT ON button [to turn on the LED (orange) on top of the SHIFT button]. Press the 16:9 OFF button [to turn off the LED (orange)] to select the 4:3 mode.
22. Press the SHIFT OFF button [to turn off the LED (orange) on top of the SHIFT button].  
Press the UNDER SCAN button (  ) to its OFF position to select the normal mode. [The green LED turns off.]
23. Adjust SUB CONTRAST so that luminance becomes 120 cd/m<sup>2</sup>.
24. Press the UNDER SCAN button (  ) to its OFF position to select the normal mode. [The green LED turns off.]
25. Adjust SUB CONTRAST so that luminance becomes 120 cd/m<sup>2</sup>.
26. Press the UNDER SCAN button (  ) to its OFF position to select the normal mode. [The green LED turns off.]

### 3.3 White Balance Adjustment (2)

1. Connect the 480/60i (525) 20 IRE WINDOW color difference signal to the ANALOG Y/G input connector.
2. Select STD using the COLOR TEMP menu of the INPUT CONFIG menu.
3. Select MAINTENANCE menu of the SYSTEM CONFIG menu.
4. Select the VIDEO menu.
5. Increase the CHROMA control to its maximum.
6. Adjust white balance by adjusting the PR/R. BLACK and PB/B. BLACK menus of the VIDEO menu.  
 $x = 0.283$   
 $y = 0.297$

### 3.4 White Balance Adjustment (3)

1. Connect the 1080/60i (1125) 20 IRE WINDOW color difference signal to the ANALOG Y/G input connector.
2. Select STD using the COLOR TEMP menu of the INPUT CONFIG menu.
3. Select MAINTENANCE menu of the SYSTEM CONFIG menu.
4. Select the VIDEO menu.
5. Increase the CHROMA control to its maximum.
6. Adjust white balance by adjusting the PR/R. BLACK and PB/B. BLACK menus of the VIDEO menu.  
 $x = 0.283$   
 $y = 0.297$

### 3.5 White Balance Adjustment (4)

1. Turn off the main POWER switch.
2. Insert the BKM-142HD into the SLOT 2.
3. Connect the HD-SDI 20 IRE WINDOW signal to the BKM-142HD.
4. Turn on the main POWER switch.
5. Select HD-SDI using the FORMAT menu of the INPUT CONFIG menu.
6. Select MAINTENANCE menu of the SYSTEM CONFIG menu.
7. Select the VIDEO menu.
8. Increase the CHROMA control to its maximum.
9. Adjust white balance by adjusting the PR/R. BLACK and PB/B. BLACK menus of the VIDEO menu.  
 $x = 0.283$   
 $y = 0.297$

### 3.6 White Balance Adjustment (5)

1. Turn off the main POWER switch.
2. Insert the BKM-120D into the SLOT 2.
3. Connect the D1-SDI 20 IRE WINDOW signal to the BKM-120D.
4. Turn on the main POWER switch.
5. Select D1-SDI using the FORMAT menu of the INPUT CONFIG menu.
6. Select MAINTENANCE menu of the SYSTEM CONFIG menu.
7. Select the VIDEO menu.
8. Increase the CHROMA control to its maximum.
9. Adjust white balance by adjusting the PR/R BLACK and PB/B BLACK menus of the VIDEO menu.  
 $x = 0.283$   
 $y = 0.297$

### 3.7 White Balance Adjustment (6)

1. Turn off the main POWER switch.
2. Insert the BKM-127W into the SLOT 2.
3. Connect the NTSC 20 IRE WINDOW signal to the BKM-127W.
4. Turn on the main POWER switch.
5. Select NTSC, PAL using the FORMAT menu of the INPUT CONFIG menu.
6. Select MAINTENANCE menu of the SYSTEM CONFIG menu.
7. Select the VIDEO menu.
8. Increase the CHROMA control to its maximum.
9. Adjust white balance by adjusting the PR/R BLACK and PB/B BLACK menus of the VIDEO menu.  
 $x = 0.283$   
 $y = 0.297$



## Section 4

### Safety Related Adjustments

This section describes the adjustment procedure that is required when the safety related parts are replaced.

#### [Preparation]

- Required tools and measuring equipment
- 1. Signal generator
  - YPBYPR signal generator
    - 1080/60i (1125) : SMPTE274M standard
    - 480/60i (525) : ITU601 (Refer to page 1-29)
- 2. Electrostatic voltmeter: Singer ESH-27X or ESH-23X or equivalent
- 3. Digital voltmeter
- 4. 200 k $\Omega$  variable resistor
- 5. 50 k $\Omega$  variable resistor
- 6. Ammeter

- Set the INPUT CONFIGURATION menu
- Set the INPUT CONFIGURATION menu of the SETUP menu as shown below unless otherwise specified.

```

FORMAT ..... YPBPR
SLOT NO ..... 1
INPUT NO ..... 1
SYNC MODE ..... INT
APEARTURE VALUE ..... 100
CHANNEL NAME ..... PROG
COLOR TEMP ..... STD
H PHASE ..... 000
MARKER PHASE ..... 000
MARKER WIDTH ..... 000
  
```

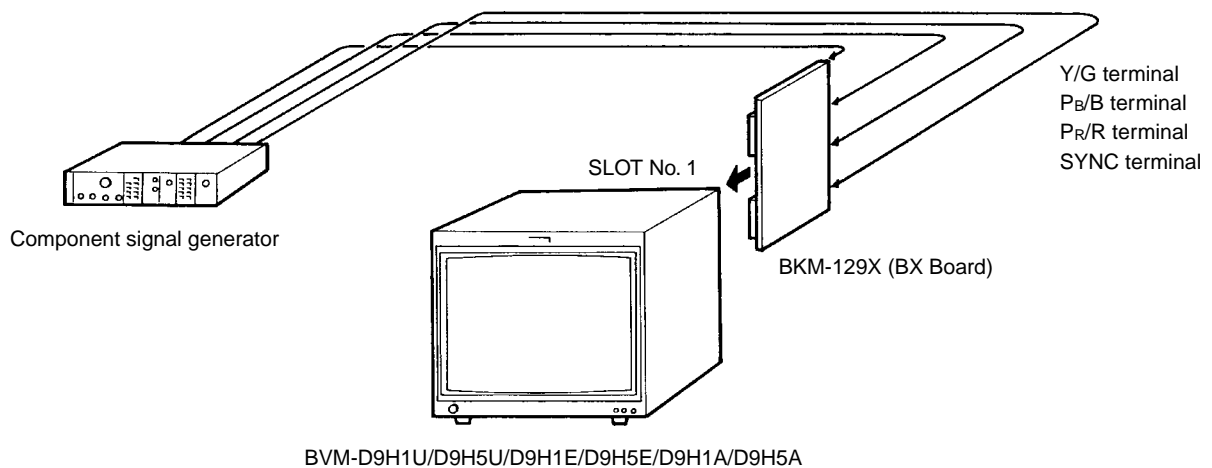

### **+B (12 V) Voltage Check**

When the following parts (the parts to which the  $\blacksquare$  mark is attached on the schematic diagram) are replaced, be sure to perform the following checks.

$\blacksquare$  G board ..... IC666, IC603, IC690, PH601, T602, T604

1. Connect a digital voltmeter between pin-1 and pin-2 (GND) of CN1602 on the D board.
2. Turn on the main power.
3. Connect the 1080/60i monoscope signal (see note) to input connector.  
Note: 1125 (1080) monoscope signal
4. Push the BRIGHTNESS and CONTRAST buttons to their MANUAL positions (to turn the green LEDs on the buttons.)
5. Set the BRIGHTNESS and CONTRAST buttons to their mechanical center positions.
6. Check that the following DC voltage appears.  
 $13.0 \pm 1.0 \text{ V}$
7. Turn off the main power.
8. Disconnect the digital voltmeter.

### **High Voltage Regulator Check**

When the following parts (the parts to which the  $\blacksquare$  mark is attached on the schematic diagram) are replaced, be sure to perform the following checks.

$\blacksquare$  P board ..... IC502, IC508, R540, R541, R543, R544, R549, R550, R555, R599

1. Turn off the main power.
2. Connect an electrostatic voltmeter to the anode cap of CRT tube.
  - Electrostatic voltmeter: It must have already been calibrated to have the input impedance of  $2 \times 10^9 \Omega$  or more.
3. Turn on the main power.
4. Connect the 1080/60i monoscope signal (see note) to input connector.  
Note: HD 1125 signal
5. Push the BRIGHTNESS and CONTRAST buttons to their MANUAL positions (to turn the green LEDs on the buttons.)
6. Set the BRIGHTNESS and CONTRAST buttons to their mechanical center positions.
7. Check that the following high voltage appears.  
 $15.5 \pm 0.4 \text{ kV}$
8. Turn off the main power.
9. Disconnect the electrostatic voltmeter.

### **[Connection]**

D board (A SIDE)

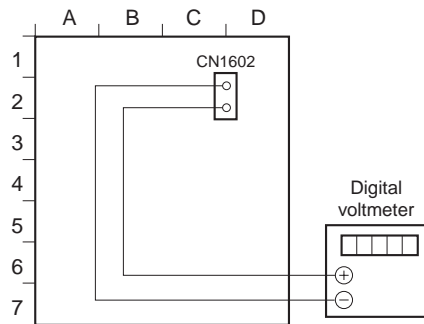



### High Voltage Hold-Down Check

When the following parts (the parts to which the  $\blacksquare$  mark is attached on the schematic diagram) are replaced, be sure to perform the following checks.

$\blacksquare$  P board ..... IC509, IC511, D527, R539, R577, R578, R579, R580, R592, R588, R587

1. Turn off the main power.
2. Connect a digital voltmeter between TP505 and TP514 (GND) of P board.
3. Connect a 200 k $\Omega$  variable resistor between TP508 and TP514 (GND) of P board.  
[Adjust the 200 k $\Omega$  variable resistor to its maximum resistance value.]
4. Turn on the main power.
5. Connect the 480/60i all black signal (see note) to input connector.  
Note: NTSC all black signal
6. Push the BRIGHTNESS and CONTRAST buttons to their MANUAL positions (to turn the green LEDs on the buttons.)
7. Set the BRIGHTNESS and CONTRAST buttons to their MIN positions.
8. Confirm that the raster disappears from the CRT screen when the DC voltage at TP505 reaches the following voltage as the 200 k $\Omega$  variable resistor is turned to decrease its resistance value gradually.  
4.90 to 5.10 V
9. Turn off the main power.
10. Remove the 200 k $\Omega$  variable resistor from TP508.
11. Turn on the main power.
12. Confirm that the DC voltage at TP505 is as follows.  
3.95  $\pm$  0.15 V
13. Connect the 480/60i entire white signal to input connector.
14. Set the BRIGHTNESS and CONTRAST buttons to their MAXIMUM positions.
15. Confirm that the DC voltage at TP505 is as follows.  
4.25  $\pm$  0.20 V
16. Disconnect the digital voltmeter.

#### [Connection] P board (Side A)

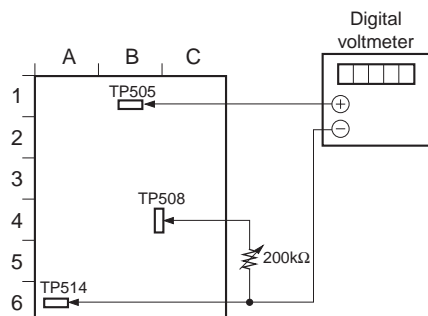

### ABL Check

When the following parts (the parts to which the  $\blacksquare$  mark is attached on the schematic diagram) are replaced, be sure to perform the following checks.

$\blacksquare$  P board ..... R1507, R1508, R1509  
 $\blacksquare$  B board ..... R1461, R1464, R1467, R1469, R1470, R1471

1. Turn off the main power.
2. Disconnect the CN504 connector from the P board.
3. Connect a DC ammeter between pin-1 and pin-3 of CN504 on the P board  
[Pin-3 is the positive (+) side.]
4. Turn on the main power.
5. Connect the 1080/60i all white signal (see note) to input connector.  
Note: 1125 (1080) entire white signal
6. Push the BRIGHTNESS and CONTRAST buttons to their MANUAL positions (to turn the green LEDs on the buttons.)
7. Check to see that ABL operates when the BRIGHTNESS and CONTRAST buttons are turned from their MIN positions toward the MAX positions. [Check that the maximum value of the DC ammeter reading is within the range as shown below.]  
0.50 to 0.60 mA
8. Turn off the main power.
9. Disconnect the DC ammeter.
10. Connect CN504 connector to the P board again.

#### [Connection]

P board (Side B)

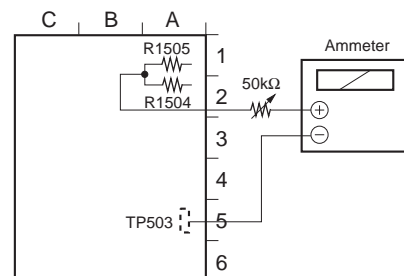

## Beam Current Protector Check

When the following parts (the parts to which the  mark is attached on the schematic diagram) are replaced, be sure to perform the following checks.

P board ..... R582, R583, R584, R585, R586, R1504, R1505, R1506

1. Turn off the main power.
2. Connect a DC ammeter and a 50 k $\Omega$  variable resistor in series between the junction point of R1504 and R1505, and TP513 (GND) on the P board.  
[The junction point of R1504 and R1505 is the positive (+) side. Adjust the 50 k $\Omega$  variable resistor to its maximum resistance beforehand.]
3. Turn on the main power.
4. Connect the 1080/60i entire black signal (see note) to input connector.  
Note: 1125 (1080) entire black signal
5. Push the BRIGHTNESS and CONTRAST buttons to their MANUAL positions (to turn the green LEDs on the buttons.)
6. Set the BRIGHTNESS and CONTRAST buttons to their mechanical center positions.
7. Confirm that the raster disappears from the CRT screen when the DC ammeter reaches the following value as the 50 k $\Omega$  variable resistor is turned to decrease its resistance value gradually.  
550  $\mu$ A
8. Turn off the main power.
9. Remove a 50 k $\Omega$  variable resistor and a DC ammeter.

# Section 5

## Circuit Adjustments

### 5-1. B Board Adjustments

This section describes the following adjustments that are required when the parts are replaced or maintenance is performed in the B board.

1. RGB signal adjustment
2. 15k YPBPR SMPTE (709) signal adjustment
3. 15k YPBPR SMPTE (601) signal adjustment
4. 15k YPBPR BETACAM SETUP 0 (601) signal adjustment
5. 15k YPBPR BETACAM SETUP 7.5 (601) signal adjustment
6. 33k YPBPR SMPTE (709) Signal Adjustment

#### Control Settings

- Set the INPUT CONFIGURATION menu of the SETUP menu as shown below.  
 FORMAT ..... YPBPR  
 SLOT NO ..... 1  
 INPUT NO ..... 1
- Set “128” to the CHROMA data using the CHROMA control knob.
- Perform the following operation using the SYSTEM CONFIG menu.  
 Select the B BOARD using the RE-LOAD FACTORY DATA of the SYSTEM menu.

#### Equipment Required

Name	Main Specifications	Model Name
Signal generator	15 kHz/60 Hz RGB 15 kHz/60 Hz YPBPR SMPTE (709) 15 kHz/60 Hz YPBPR SMPTE (601) 15 kHz/60 Hz YPBPR BETACAM SETUP 7.5 (601) 33 kHz/60 Hz YPBPR SMPTE (709)	VG-854 or equivalent
Oscilloscope	Frequency: DC to 150 MHz or more Dual trace	TEKTRONIX 2445A or equivalent

#### Connection (1)

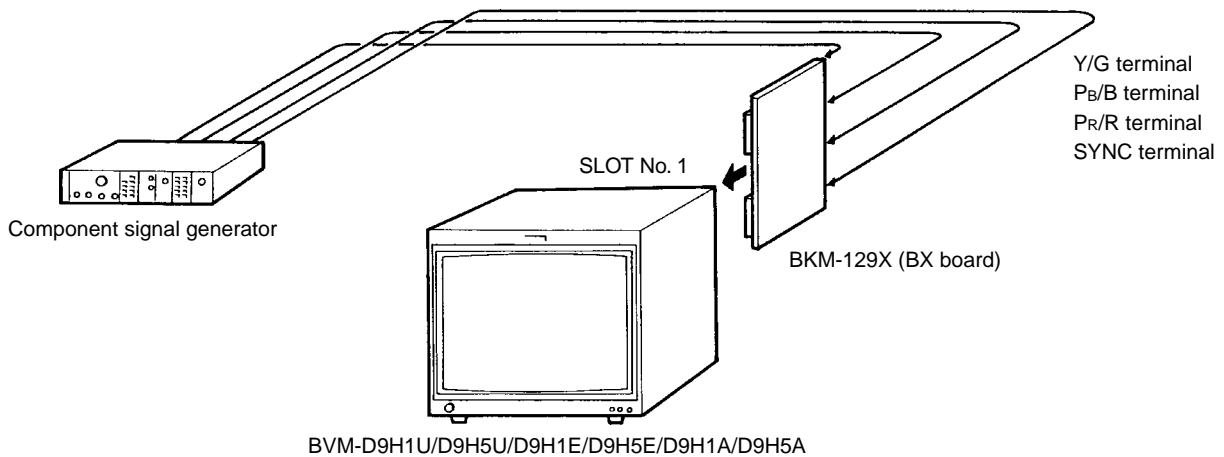

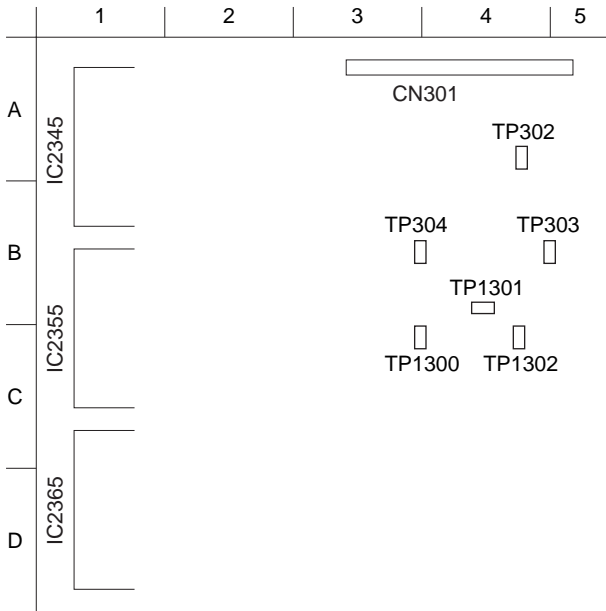

**Connection (2)  
B Board -side A-**



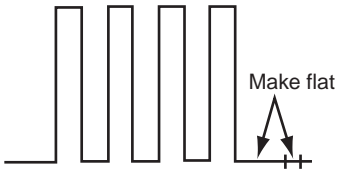

**Adjustment Procedure**

**1. RGB Signal Adjustment**

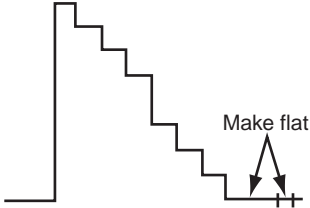
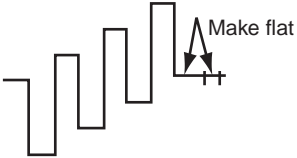

Status During Adjustment	Specifications	Adjustment Point
<p>Step 1</p> <ul style="list-style-type: none"> <li>Input the 15 kHz/60 Hz RGB 100% color bar signal.</li> <li>Use the FORMAT item of the INPUT CONFIG menu to select RGB.</li> <li>Connect an oscilloscope to TP302.</li> </ul>	<p>Adjust the GREEN waveforms to have the same amplitude at TP302.</p> <p>Level difference: <math>0 \pm 10</math> mV</p> 	<p>Use the adjustment menu Y/G BLACK (40H) that is located under the directory of the VIDEO menu of the MAINTENANCE menu.</p>
<p>Step 2</p> <ul style="list-style-type: none"> <li>Connect an oscilloscope to TP303.</li> </ul>	<p>Make flat the pedestal portion of the BLUE waveform at TP303.</p> <p>Level difference: <math>0 \pm 10</math> mV</p> 	<p>Use the adjustment menu PB/B BLACK (30H) that is located under the directory of the VIDEO menu of the MAINTENANCE menu.</p>
<p>Step 3</p> <ul style="list-style-type: none"> <li>Connect an oscilloscope to TP304.</li> </ul>	<p>Make flat the pedestal portion of the RED waveform at TP304.</p> <p>Level difference: <math>0 \pm 10</math> mV</p> 	<p>Use the adjustment menu PR/R BLACK (20H) that is located under the directory of the VIDEO menu of the MAINTENANCE menu.</p>

## 2. 15k YPBPR SMPTE (709) Signal Adjustment

### 2-1. BLACK Level Adjustment

Status During Adjustment	Specifications	Adjustment Point
<p>Step 1</p> <ul style="list-style-type: none"> <li>Input the 15 kHz/60 Hz YPBPR SMPTE (709) 100% color bar signal.</li> <li>Use the FORMAT item of the INPUT CONFIG menu to select YPBPR SMPTE. Set 709 for YPBPR MATRIX.</li> <li>Connect an oscilloscope to TP302.</li> </ul>	<p>Make flat the pedestal portion of the Y-signal waveform at TP302.</p> <p>Level difference: <math>0 \pm 10</math> mV</p> 	<p>Use the adjustment menu Y/G BLACK (41H) that is located under the directory of the VIDEO menu of the MAINTENANCE menu.</p>
<p>Step 2</p> <ul style="list-style-type: none"> <li>Connect an oscilloscope to TP303.</li> </ul>	<p>Make flat the pedestal portion of the PB waveform at TP303.</p> <p>Level difference: <math>0 \pm 10</math> mV</p> 	<p>Use the adjustment menu PB/B BLACK (32H) that is located under the directory of the VIDEO menu of the MAINTENANCE menu.</p>
<p>Step 3</p> <ul style="list-style-type: none"> <li>Connect an oscilloscope to TP304.</li> </ul>	<p>Make flat the pedestal portion of the PR waveform at TP304.</p> <p>Level difference: <math>0 \pm 10</math> mV</p> 	<p>Use the adjustment menu PR/R BLACK (22H) that is located under the directory of the VIDEO menu of the MAINTENANCE menu.</p>

### 2-2. CHROMA Leak Adjustment

Status During Adjustment	Specifications	Adjustment Point
<p>Step 1</p> <ul style="list-style-type: none"> <li>Input the 15 kHz/60 Hz YPBPR SMPTE (709) 100% color bar signal.</li> <li>Use the FORMAT item of the INPUT CONFIG menu to select YPBPR SMPTE. Set 709 for YPBPR MATRIX.</li> <li>Use the CHROMA knob to set "0" to the CHROMA data.</li> <li>Connect an oscilloscope to TP303.</li> </ul>	<p>Make flat the PB waveform at TP303.</p> <p>Level difference: <math>0 \pm 20</math> mV</p>  <p>Make the signal amplitude as flat as possible.</p>	<p>Use the adjustment menu CHROMA PB (11H) that is located under the directory of the VIDEO menu of the MAINTENANCE menu.</p>
<p>Step 2</p> <ul style="list-style-type: none"> <li>Connect an oscilloscope to TP304.</li> </ul>	<p>Make flat the PR waveform at TP304.</p> <p>Level difference: <math>0 \pm 20</math> mV</p>  <p>Make the signal amplitude as flat as possible.</p>	<p>Use the adjustment menu CHROMA PR (10H) that is located under the directory of the VIDEO menu of the MAINTENANCE menu.</p>
<p>Step 3</p> <ul style="list-style-type: none"> <li>Set "128" to the CHROMA data using the CHROMA control knob.</li> </ul>		

## 2-3. MATRIX Adjustment

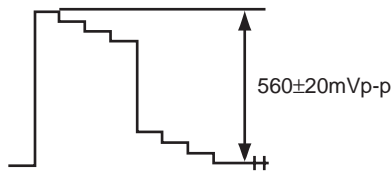
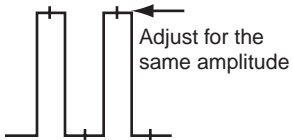
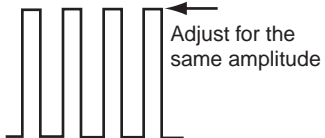
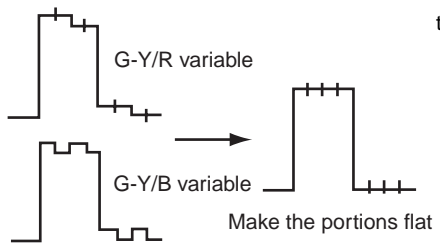
Status During Adjustment	Specifications	Adjustment Point
<p>Step 1</p> <ul style="list-style-type: none"> <li>Input the 15 kHz/60 Hz YPBPR SMPTE (709) 100% color bar signal.</li> <li>Use the FORMAT item of the INPUT CONFIG menu to select YPBPR SMPTE. Set 709 for YPBPR MATRIX.</li> <li>Connect an oscilloscope to TP1301.</li> </ul>	<p>GREEN waveform amplitude at TP1301:  <math>560 \pm 20</math> mVp-p</p> 	<p>Use the adjustment menu Y LEVEL (50H) that is located under the directory of the VIDEO menu of the MAINTENANCE menu.</p>
<p>Step 2</p> <ul style="list-style-type: none"> <li>Connect an oscilloscope to TP1300.</li> </ul>	<p>Adjust the RED waveforms to have the same amplitude at TP1300.            Level difference: <math>0 \pm 20</math> mV</p> 	<p>Use the adjustment menu PR LEVEL (60H) that is located under the directory of the VIDEO menu of the MAINTENANCE menu.</p>
<p>Step 3</p> <ul style="list-style-type: none"> <li>Connect an oscilloscope to TP1302.</li> </ul>	<p>Adjust the BLUE waveforms to have the same amplitude at TP1302.            Level difference: <math>0 \pm 20</math> mV</p> 	<p>Use the adjustment menu PB LEVEL (80H) that is located under the directory of the VIDEO menu of the MAINTENANCE menu.</p>
<p>Step 4</p> <ul style="list-style-type: none"> <li>Connect an oscilloscope to TP1301.</li> </ul>	<p>Make flat the GREEN waveform at TP1301            Level difference: <math>0 \pm 20</math> mV</p> 	<p>Use the adjustment menu G-Y/R (70H) and G-Y/B (90H) that is located under the directory of the VIDEO menu of the MAINTENANCE menu.</p>

### 3. 15k YPBPR SMPTE (601) Signal Adjustment

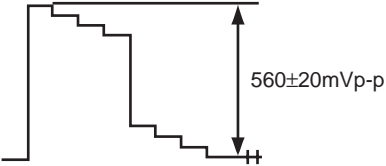
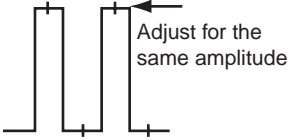
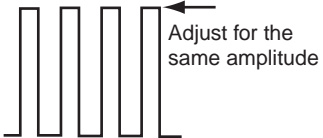
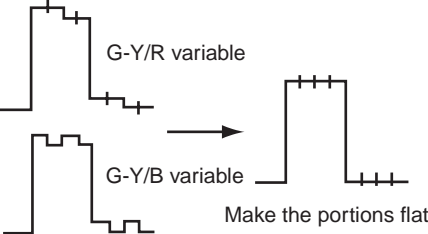
Status During Adjustment	Specifications	Adjustment Point
<p>Step 1</p> <ul style="list-style-type: none"> <li>Input the 15 kHz/60 Hz YPBPR SMPTE (601) 100% color bar signal.</li> <li>Use the FORMAT item of the INPUT CONFIG menu to select YPBPR SMPTE. Set 601 for YPBPR MATRIX.</li> <li>Connect an oscilloscope to TP1301.</li> </ul>	<p>GREEN waveform amplitude at TP1301:  <math>560 \pm 20</math> mVp-p</p> 	<p>Use the adjustment menu Y LEVEL (51H) that is located under the directory of the VIDEO menu of the MAINTENANCE menu.</p>
<p>Step 2</p> <ul style="list-style-type: none"> <li>Connect an oscilloscope to TP1300.</li> </ul>	<p>Adjust the RED waveforms to have the same amplitude at TP1300.            Level difference: <math>0 \pm 20</math> mV</p> 	<p>Use the adjustment menu PR LEVEL (62H) that is located under the directory of the VIDEO menu of the MAINTENANCE menu.</p>
<p>Step 3</p> <ul style="list-style-type: none"> <li>Connect an oscilloscope to TP1302</li> </ul>	<p>Adjust the BLUE waveforms to have the same amplitude at TP1302.            Level difference: <math>0 \pm 20</math> mV</p> 	<p>Use the adjustment menu PB LEVEL (82H) that is located under the directory of the VIDEO menu of the MAINTENANCE menu.</p>
<p>Step 4</p> <ul style="list-style-type: none"> <li>Connect an oscilloscope to TP1301.</li> </ul>	<p>Make flat the GREEN waveform at TP1301 :            Level difference: <math>0 \pm 20</math> mV</p> 	<p>Use the adjustment menu G-Y/R (71H) and G-Y/B (91H) that is located under the directory of the VIDEO menu of the MAINTENANCE menu.</p>

#### 4. 15k YPBPR BETACAM SETUP 0 (601) Signal Adjustment

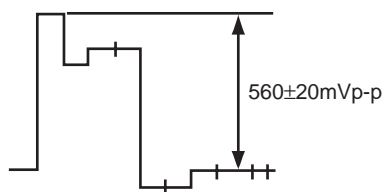
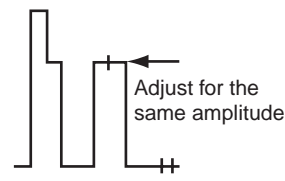
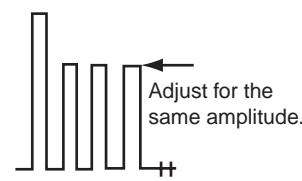
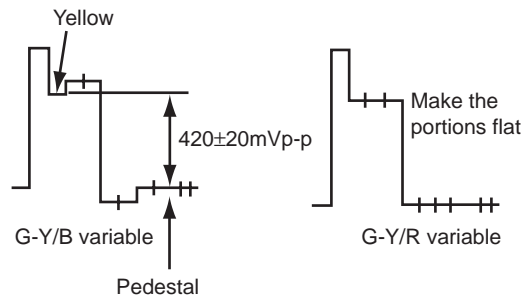
Status During Adjustment	Specifications	Adjustment Point
<p>Step 1</p> <ul style="list-style-type: none"> <li>Input the 15 kHz/60 Hz YPBPR BETACAM SETUP 0 (601) 75% color bar signal.</li> <li>Use the FORMAT item of the INPUT CONFIG menu to select YPBPR BETA 0.</li> <li>Connect an oscilloscope to TP1301.</li> </ul>	<p>GREEN waveform amplitude at TP1301:</p> <p><math>560 \pm 20 \text{ mVp-p}</math></p> 	<p>Use the adjustment menu Y LEVEL (52H) that is located under the directory of the VIDEO menu of the MAINTENANCE menu.</p>
<p>Step 2</p> <ul style="list-style-type: none"> <li>Connect an oscilloscope to TP1300.</li> </ul>	<p>Adjust the RED waveforms to have the same amplitude at TP1300.</p> <p>Level difference: <math>0 \pm 20 \text{ mV}</math></p> 	<p>Use the adjustment menu PR LEVEL (64H) that is located under the directory of the VIDEO menu of the MAINTENANCE menu.</p>
<p>Step 3</p> <ul style="list-style-type: none"> <li>Connect an oscilloscope to TP1302.</li> </ul>	<p>Adjust the BLUE waveforms to have the same amplitude at TP1302.</p> <p>Level difference: <math>0 \pm 20 \text{ mV}</math></p> 	<p>Use the adjustment menu PB LEVEL (84H) that is located under the directory of the VIDEO menu of the MAINTENANCE menu.</p>
<p>Step 4</p> <ul style="list-style-type: none"> <li>Connect an oscilloscope to TP1301.</li> </ul>	<p>Make flat the GREEN waveform at TP1301.</p> <p>Amplitude between YELLOW and pedestal: <math>420 \pm 20 \text{ mVp-p}</math></p> <p>Make flat the waveform: Level difference: <math>0 \pm 20 \text{ mV}</math></p> 	<p>Use the adjustment menu G-Y/R (72H) and G-Y/B (92H) that is located under the directory of the VIDEO menu of the MAINTENANCE menu.</p>

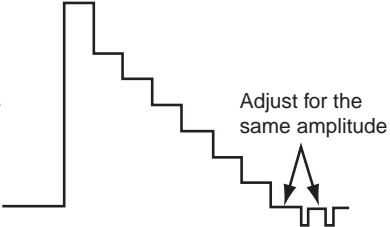
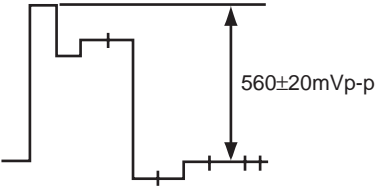
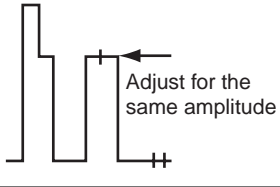
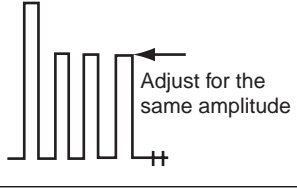
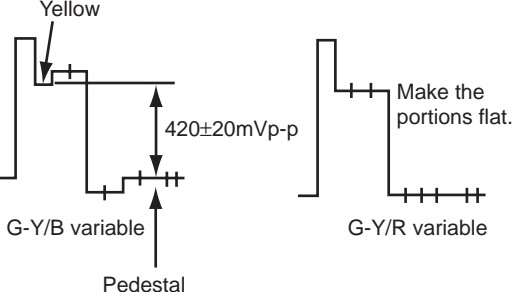

## 5. 15k YPBPR BETACAM SETUP 7.5 (601) Signal Adjustment

Status During Adjustment	Specifications	Adjustment Point
<p>Step 1</p> <ul style="list-style-type: none"> <li>Input the 15 kHz/60 Hz YPBPR BETACAM SETUP 7.5 (601) 75% color bar signal.</li> <li>Use the FORMAT item of the INPUT CONFIG menu to select YPBPR BETA 7.5.</li> <li>Connect an oscilloscope to TP302.</li> </ul>	<p>Make flat the pedestal portion of the Y-signal waveform at TP302.</p> <p>Level difference: <math>0 \pm 10</math> mV</p> 	<p>Use the adjustment menu Y/G BLACK (42H) that is located under the directory of the VIDEO menu of the MAINTENANCE menu.</p>
<p>Step 2</p> <ul style="list-style-type: none"> <li>Connect an oscilloscope to TP1301.</li> </ul>	<p>GREEN waveform amplitude at TP1301:</p> <p><math>560 \pm 20</math> mVp-p</p> 	<p>Use the adjustment menu Y LEVEL (53H) that is located under the directory of the VIDEO menu of the MAINTENANCE menu.</p>
<p>Step 3</p> <ul style="list-style-type: none"> <li>Connect an oscilloscope to TP1300.</li> </ul>	<p>Adjust the RED waveforms to have the same amplitude at TP1300.</p> <p>Level difference: <math>0 \pm 20</math> mV</p> 	<p>Use the adjustment menu PR LEVEL (65H) that is located under the directory of the VIDEO menu of the MAINTENANCE menu.</p>
<p>Step 4</p> <ul style="list-style-type: none"> <li>Connect an oscilloscope to TP1302.</li> </ul>	<p>Adjust the BLUE waveforms to have the same amplitude at TP1302.</p> <p>Level difference: <math>0 \pm 20</math> mV</p> 	<p>Use the adjustment menu PB LEVEL (85H) that is located under the directory of the VIDEO menu of the MAINTENANCE menu.</p>
<p>Step 5</p> <ul style="list-style-type: none"> <li>Connect an oscilloscope to TP1301.</li> </ul>	<p>Make flat the GREEN waveform at TP1301.</p> <p>Amplitude between YELLOW and pedestal:</p> <p><math>420 \pm 20</math> mVp-p</p> <p>Make flat the waveform:</p> <p>Level difference: <math>0 \pm 20</math> mV</p> 	<p>Use the adjustment menu G-Y/R (73H) and G-Y/B (93H) that is located under the directory of the VIDEO menu of the MAINTENANCE menu.</p>

## 6. 33k YPBPR SMPTE (709) Signal Adjustment

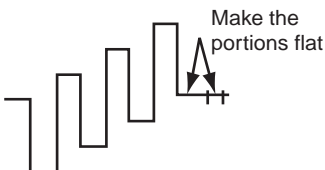
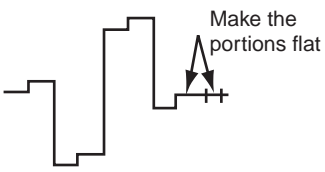
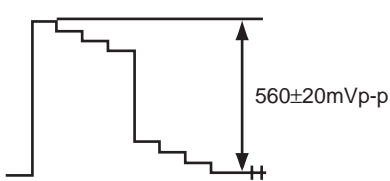
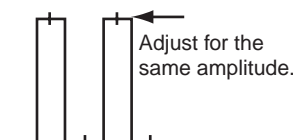
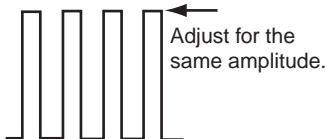
Status During Adjustment	Specifications	Adjustment Point
<p>Step 1</p> <ul style="list-style-type: none"> <li>Input the 33 kHz/60 Hz YPBPR SMPTE (709) 100% color bar signal.</li> <li>Use the FORMAT item of the INPUT CONFIG menu to select YPBPR SMPTE.</li> <li>Connect an oscilloscope to TP303.</li> </ul>	<p>Make flat the PB waveform at TP303.</p> <p>Level difference: <math>0 \pm 10</math> mV</p> 	<p>Use the adjustment menu PB/B BLACK (33H) that is located under the directory of the VIDEO menu of the MAINTENANCE menu.</p>
<p>Step 2</p> <ul style="list-style-type: none"> <li>Connect an oscilloscope to TP304.</li> </ul>	<p>Make flat the PR waveform at TP304.</p> <p>Level difference: <math>0 \pm 10</math> mV</p> 	<p>Use the adjustment menu PR/R BLACK (23H) that is located under the directory of the VIDEO menu of the MAINTENANCE menu.</p>
<p>Step 3</p> <ul style="list-style-type: none"> <li>Connect an oscilloscope to TP1301.</li> </ul>	<p>Check amplitude of the GREEN waveform at TP1301: <math>560 \pm 20</math> mVp-p</p> 	
<p>Step 4</p> <ul style="list-style-type: none"> <li>Connect an oscilloscope to TP1300.</li> </ul>	<p>Adjust the RED waveforms to have the same amplitude at TP1300.</p> <p>Level difference: <math>0 \pm 20</math> mV</p> 	<p>Use the adjustment menu PR LEVEL (61H) that is located under the directory of the VIDEO menu of the MAINTENANCE menu.</p>
<p>Step 5</p> <ul style="list-style-type: none"> <li>Connect an oscilloscope to TP1302.</li> </ul>	<p>Adjust the BLUE waveforms to have the same amplitude at TP1302.</p> <p>Level difference: <math>0 \pm 20</math> mV</p> 	<p>Use the adjustment menu PB LEVEL (81H) that is located under the directory of the VIDEO menu of the MAINTENANCE menu.</p>

## Section 6

# Circuit Descriptions

This section describes the circuit operations of the following boards used in the BVM-D9H1/D9H5.

- 6-1. G board
- 6-2. B board
- 6-3. MA board
- 6-4. MB board
- 6-5. D board P1 and P2
- 6-6. P board
- 6-7. HA, HB and HC boards
- 6-8. HD board

### 6-1. G Board

Power supply of this monitor consists of the following two switching regulators.

1. The power factor improvement regulator that is used to comply with the power supply high frequency harmonics regulations.
2. The main regulator that supplies the power to the signal system, the deflection circuit and high voltage circuit.

#### 1. Power Factor Improvement Circuit

The power factor improvement circuit of this monitor uses the active filter IC module (IC601) of the current-threshold type boost-chopper system to comply with the power supply high frequency harmonics regulations. In this monitor, the output voltage  $V_{pfc}$  becomes always higher than the peak value of the input voltage to the power circuit. The output voltage  $V_{pfc}$  of this monitor is set to about 370 V.

The power factor improvement circuit consists of IC666, T602, C630 and C615.

IC666 is a module IC in which the control IC, the switching FET, the boost diode and input/output voltage detectors are built in.

Basic operation of the power factor improvement block is as follows. When the  $V_{cc}$  power is supplied to IC666, the FET inside the module IC666 is turned on and an electric current starts to flow in the primary winding of T602 and the FET. This current increases with the slope of  $V_{in}(\text{rms})/L$  where  $L$  is the primary side's inductance of T602. This FET current is monitored by the source current detection resistor that is connected between pin-4 and pin-7 of IC666. When this FET current reaches the set value that is specified by the multiplier inside the control IC, the

FET is turned off. Then an electric current flows through the boost diode where the current decreases with the slope of  $-(V_{pfc} - V_{in}(\text{rms}))/L$ . When this current reaches 0, the FET is turned on. The current-threshold operation is thus realized by the above described circuit operations.

In other words, the circuit operations that are described, are performed as one-operation-cycle all the time while the power is on. When you observe the circuit operations as described above, during only the half-wave period of commercial power line frequency, you will notice that ON/OFF timing of the FET is controlled by the control IC so that the envelope of the peak values of the choke current is proportional to the half-wave of the sine waveform of the power line frequency. As the result of this control, waveform of the input voltage and that of the output voltage become similar so that the power factor is improved.

#### 2. Main Regulator

The separately excited current composite resonance system is used for the main regulator. The power regulation with high efficiency and low noise is thus realized. The main regulator consists of IC603, IC690, T604, C644, C623 and the secondary side rectifier circuit of T604. IC603 is a multiple chip module in which the four chips of the control block, the FET drive block and the switching FET block (high side and low side) are connected by bonding wire inside the IC. The main regulator has the following circuit configuration. A half-bridge rectifier is constructed by the two FET switches, the two capacitors C644 and C623, and the transformer T604 for the input voltage  $V_{pfc}$ . The secondary side of the transformer has the full wave rectifier having the center tap.

IC603 receives the control signal from IC690 that performs the constant voltage control over the +13 V line through the isolator PH601. The control signal changes the oscillating frequency of IC603 so that the constant voltage control is realized.

## 6-2. B board

### 1. Clamp Circuit (1)

The signal that is selected by the option board is input to CN301.

IC300 (1/3) (analog switch) is turned ON by the Y-CLP-P pulse. As a result, the pedestal voltage of the Y/G signal is sampled-and-held. In IC303, the sampled-and-held voltage and the reference voltage (Y/G BLACK voltage) are compared so that the error voltage is used to control the bias current of the Y/G signal clamp amplifier (Q300 to Q302) so that the pedestal voltage of the Y/G signal is clamped to a fixed voltage.

The same clamp operation is performed for the PB/B and PR/R signals but the C-CLP-P pulse is used as the clamp pulse.

### 2. Matrix Circuit

The Y, R-Y and B-Y signals are converted to the R, G and B signals by the matrix circuit during the Y/PB/PR mode. IC306 is the Y-level adjustment amplifier. IC307 and IC308 are the chroma level adjustment amplifier. The R-signal is generated by adding the Y-signal to the R-Y signal that has passed IC400 (PR gain control amplifier). The G-signal is generated by adding the R-Y signal that has passed IC400 (PR gain control amplifier), the B-Y signal that has passed IC401 (PB gain control amplifier) and the Y-signal that is inverted and amplified. These signals are added at Q463. The B-signal is generated by adding the Y-signal to the B-Y signal that has passed IC401 (PB gain control amplifier).

### 3. RGB Selector Switch

IC1300 (1/3), IC1302 (1/3) and IC1303 (1/3) are the selector switch selecting either the RGB signal or the YPBPR signal (matrix circuit). Output of the selector switch is R, G and B signals.

### 4. Clamp Circuit (2)

The R-signal is sampled-and-held by the timing pulse of the deflection system.

IC1305 compares the sampled R-signal with the reference signal. The error voltage of the comparator controls the DC bias of the R-signal amplifiers (Q1300 to Q1302) so that the pedestal level is kept to a constant DC level all the time. The same clamp operation is performed in the G and B signals in the same way.

### 5. OSD Insertion Circuit

The on-screen display of the R-signal is realized by inserting the OSD blanking with IC1300 (2/3) and by inserting the OSD characters with IC1304 (1/3). The WINDOW signal that is used during the AUTO W/B adjustment is also created by the character generator, and uses the same signal line in the same way of the character display. The same insertion operation is performed in the G and B signals in the same way.

### 6. CUT-OFF Circuit

Cut-off of the R-signal is performed by IC1304 (2/3, 3/3). The same cut-off operation is performed in the G and B signals in the same way.

### 7. CXA1739 Peripheral Circuit

The RGB signal is input during the normal operation and the color difference signal is input during the blue-only mode.

### 8. ABL Circuit

The ABL circuit consists of Q1460 for ABL, and Q1461 for BRT ABL.

The ABL voltage from the deflection block is input the respective emitters of Q1460 and Q1461. The voltage-divided DC voltage of the ABL signal is input the respective bases of Q1460 and Q1461. Their collectors are connected to IC1401 pin-46 (PIC CONT) and pin-7 (BRT CONT) respectively. When these transistors are turned on, the ABL operation can be performed by decreasing their respective control voltages.

### 9. AUTO CHROMA PHASE

The signals that are output from IC1401 are selected by IC2380. Only the sample pulse portion of the selected signal is sampled by IC2381 and is compared with the output by IC2382. The error signal from the comparator is fed back to DAC through IC2383 and automatically controls the PB LEVEL or the R LEVEL until the output agrees with the sampled level.

## 10. B1 Board

The B1 board is an aperture correction circuit.

The aperture correction performs the frequency compensation at 5 MHz when the input signal is 480/60i and 575/501 with DL400/DL401. It performs the frequency compensation at 16 MHz with DL402 and DL403 when any other signals are input.

DL404 and DL405 are the delay lines that correct the delay amount of the Y-signal. The PB and PR signals are corrected of their delay by DL501, DL502, DL503 and DL504.

Amount of compensation can be varied by 2 to 6 dB when the APT is ON using the IC450 aperture correction amplifier.

## 11. Sync Separator Circuit/B2 Board

The sync separator circuit consists of the sync AGC circuit and the B2 board.

Either the input sync signal in the modes of 480/60i and 575/50i or that in any other modes, is selected by IC3301 (2/3), (3/3), Q3302 and Q3303. The sync signal is separated by the SYNC AGC circuit of Q3304 to Q3319.

Either INT sync or EXT sync is selected by IC3301 (1/3).

In the B2 board, the equalizing pulses are extracted by IC3901, the H. sync pulse is separated by the H. SYNC SEP circuit consisting of IC3904, IC3905, IC3906 and IC3907. The V. sync pulse is separated by the V. SYNC SEP. circuit consisting of Q3905, Q3907, Q3908.

The switch IC3902 is the selector switch that selects either the internal sync separator output or the already separated H. and V. sync signals that are input when the SDI signal is used.

## 12. Drive circuit

IC2345 is the R-signal drive circuit.

Q2377 is the auto cut-off circuit. Output pulse from Q2377 flows through R3363 through Q2346 when Q2377 is turned ON.

The reference pulse that is current-to-voltage converted by R3363 is input to IC1401 pin-25 through a buffer in the B board in order to activate the auto cut-off circuit.

The same circuit operation is applied to the G-signal circuit and the B-signal circuit.

## 6-3. MA board

### 1. System Control

IC106 (system control CPU) controls the monitor in accordance with the program that is installed in IC108 (flash EEPROM). The program in IC108 can be re-written by the boot loader program in IC106. Various settings are saved in the SRAM (IC111) that is backed up by battery.

### 2. Internal Bus inside Monitor

Most blocks of the deflection circuit and the signal circuit are controlled by the I2C bus that is driven by IC103 (5/6), (6/6). The I2C bus is controlled of its operation by controlling the general purpose port of IC106 by software. IC112 is an expansion I/O unit that is used to control the internal bus and the TALLY LED.

### 3. Connection to Options

The respective option boards are controlled by IC101 (1/4), (2/4), (3/4), IC103 (1/6), (2/6), (3/6), (4/6) and IC104. The data communication between the monitor and the option slot bus uses the strobe/hand-shake method using the SLOT ID signal. Data is transferred by MISO/MOSI/SCLK. The MISO/MOSI/SCLK signal is also used for communication between the MA board and the MB board. IC112 is the RS-422 driver that establishes communication to read the key data or knob information of the internal controller or of the control unit and to turn on/off the LEDs.

## 6-4. MB board

### 1. Character Display and Internal Signal Generator

IC1107 is the character generator IC such as menu characters. IC1110 generates the 4:3 marker and the various signals for automatic adjustments.

Outputs of the two ICs are mixed by IC1100 and are output.

### 2. Serial Communication Driver

IC1105 is the communication controller for the serial remote control. It performs the transmission and reception of the serial remote communication data together with the RS-485 driver of IC1103 and IC1106.

IC1108 (communication controller) and IC1109 (RS-232 driver) perform the transmission and reception of the OPTION terminals.

### 3. Parallel Remote Control

IC1112 reads out the status of the parallel remote terminal and transfers it to the CPU in the MA board.

## 6-5. D Board P1 and P2

### 1. D board - P1

The P1 block of the D board is the DC-DC converter circuit that generates the following power voltages to be used in the monitor: Standby 5 V (abbreviated as ST5 hereafter), +/- 12 V, +/- 6 V, +/- 5 V, + 24 V and the floating power source (HC+, HC-, HC N) for the H. CENTER circuit.

The DC-DC converter receives the DC power input (the DC input voltage line is called DC. IN) from various sources such as the DC input that is generated by the external power supply board (G board) or the DC input from lithium-ion battery or the DC input that is directly supplied from any external DC power supplies. The acceptable range of the DC. IN input voltage is from 11 V to 17 V. The DC. IN input voltage is compared with the output of the shunt regulator IC1601 by the comparator Q1601. When the DC voltage of 11 V or less or 17 V or higher is input, the relay RY1601 that is inserted in the input line, is activated to turn off the DC power input in order to protect the subsequent circuit from being damaged. The DC voltage that is supplied from the power supply board is 13 V. ST5V is generated by the PWM controller consisting of IC1602 and FET Q1604 that is a regulator. The output voltage from the regulator is voltage-divided and is compared with the reference voltage that is created by IC1601, by the comparator IC1602. The error output from the comparator controls the ON time of the pulse amplitude (frequency of the pulse is about 66 kHz) that is applied to Q1604 gate. ST5V is always output whenever the DC. IN voltage is input, and does not depend upon the POWER switch operation. The circuit Q1608 to Q1610 is the switch that turns off the PWM IC output when the DC. IN input voltage is outside the operating range of this regulator circuit. Q1611 to Q1613 are the transistors to drive Q1614.

+6 V power is generated by the PWM controller IC2601 and the regulator FET Q2607. -6 V power is generated by the PWM controller IC2601 and the regulator FET Q2612.  $\pm 6$  V power depends on the POWER switch. Output of the  $\pm 6$  V power is controlled by the control signal that is supplied from microprocessor. When the POWER switch is turned off, output from IC2601 is turned off by Q1617, Q2601 to Q2603 so that  $\pm 6$  V power output is turned off.  $\pm 5$  V power is generated by the 3-terminal regulator IC2602 and IC2603 from the  $\pm 6$  V input power.  $\pm 12$  V power is generated by the PWM controller IC3601 and regulator FET Q3607, Q3609 and Q3613.

This output is also controlled by the output signal from microprocessor in the same manner as in the case of  $\pm 6$  V power.

The floating power voltages (HC+, HC- and HC N) are generated by rectifying and smoothing out the output voltage from the secondary winding of the transformer T3601 that receives the DC. IN voltage to its primary winding after the DC. IN voltage is switched by the +12 V regulator FET.

24 V power is generated by rectifying and smoothing out the voltage that is induced across pin-5 and pin-6 of T3601 that receives the input power at its primary winding pin-7.

### 2. D board - P2

The P2 block of the D board consists of the horizontal and vertical sync signal processing, sync signal delay processing, deflection system control, BLKG signal processing, +B power supply circuit for horizontal output, horizontal and vertical output circuits and the H. CENTER circuit.

- Sync Signal Processing, Sync Signal Delay Processing and Deflection System Control Circuits

The horizontal and vertical sync signals that are input from CN2501 (pins-1/-2) are sent to the H/V DELAY timing circuit consisting of IC2513, IC2512, IC2509 and IC2519. The H/V DELAY timing circuit outputs the signal that repeats H/L at every half-cycle of the H. and V. input signals. This output signal is shaped of its pulse-width by IC2505 and is sent to IC2503 that is the deflection system signal processing IC. During normal operation of the monitor, the H/V DELAY timing circuit outputs the sync signals that have the same phase as those of the input signal. However, during the H. DELAY mode and the V. DELAY mode, the signal that is inverted of its phase by IC2517 and IC2516 is input to IC2505, the output sync signals are generated from the edges that correspond to the half-cycle of both horizontal and vertical periods. Thus the H. DELAY and the V. DELAY are realized.

The deflection signal processor IC2503 (TDA9106) outputs the various signals that are required for deflection, such as horizontal drive signal, parabola signal for dynamic focusing, parabola signal for picture distortion correction, vertical drive signal and H/V blanking signals. These output signals are controlled directly by the microprocessor in the MA board through I2C bus. The horizontal free-running frequency is set for about 18 kHz. The pull-in range of the input signal frequency is from 15 kHz to 45 kHz.

The deflection signal processor IC2503 has the built-in protector for X-ray irradiation. When its pin-15 is raised to 8 V or higher, the X-ray protection circuit starts working to stop the horizontal and vertical outputs. The X-ray protector circuit can be reset by turning off the main power once then back on.

There can be a case that the monitor receives the non-standard TV signal such as the output signal from VTR. In order to reduce the skew effect on screen caused by irregular timing of the input sync signal, the PLL circuit inside the IC2503 is stopped using the PLL stop signal that is output from IC2523 during the vertical blanking period. This function is effective when the horizontal frequency of the input signal is 15 kHz (480/60i, 575/50i, etc.) Because this circuit produces an ill effect when the standard TV signal is input, use or not-use of this circuit can be selected from the on-screen menu.

- BLK Signal Processing

The H. blanking circuit consists of IC2513, IC2521, IC2506 and the peripheral circuit. The timing reference signal for the horizontal blanking is the H. DF signal (parabola waveform of horizontal cycle) that is output from IC2503 pin-17. The start position of the horizontal blanking period is determined by creating a pulse by comparing the parabola waveform with a certain DC level at IC2506, and by comparing the output pulse with the waveform that is output from IC2503 pin-22 (H. BLKG). IC2513 determines the end position of the horizontal blanking.

The V. blanking circuit consists of IC2509, IC2522 and the peripheral circuit. The start position of the V. blanking is determined by the fall-down edge of the VD-signal that is output from IC2503 pin-29. The end position of the V. blanking is determined by IC2509. The H/V blanking signal are controlled of its timing by the control voltage that is output from IC2501 (D/A converter).

- +B Power Supply Circuit for Horizontal Output

The +B power supply circuit for horizontal output consists of Q2509, L2503, D2505, C2542 and other devices.

This circuit uses the step-up chopper circuit in order to produce the + B power in which the DC. IN input voltage is stepped up by switching. When Q2509 is turned on, a current flows from drain to source of Q2509 through L2503. When Q2509 is turned off, a counter electromotive force is generated across L2503 that charges C2542 through D2505 and generates the +B

voltage. Relationship between DC. IN and +B voltage is shown below.

$$V (+B) = DC. IN + V (L2503)$$

It means that the output voltage can be changed in accordance with the amount of energy that is stored in L2503. In the other words, the output voltage can be controlled by controlling the ON time of Q2509.

The +B power for the horizontal deflection system is controlled by the PWM IC IC502.

The H. size control DC voltage is super-imposed upon the horizontal PIN distortion correction signal that is output from IC2503 pin-31. The super-imposed signal is compared with the signal that is fed back from the horizontal output circuit. The error signal of the comparator is the PWM control signal (H. PWM) that is output from IC502 pin-11. The PWM control output signal is amplified by Q2507 and Q2508, then is sent to Q2509 gate so that it drives Q2509.

- Horizontal Output Circuit

The drive signal (HD) for the horizontal output signal is output from IC2503 pin-21, amplified by Q2512, Q2513, Q2535 and drives T2503 (HDT). The HD signal that is current-amplified by HDT, drives Q2514 and generates the collector pulse by the resonance of the horizontal winding of DY, the S-shape capacitor C2562, C2563 and C2564. The collector pulse generates the AGC pulse having 5 Vp-p with C2556, C2557, C2558, IC2508 and the peripheral circuit. The AGC pulse is sent to the deflection system control IC (IC2503), signal system B board, microprocessor control system MA board.

The horizontal deflection current that flows through the DY is detected of its peak value as the voltage data by T2502 and is sent to IC502 that is the horizontal deflection control PWM IC on the P board. For the linearity compensation of the screen, the right half of a screen is compensated by the S-shape capacitors (C2562 to C2564) and the left half of a screen is compensated by HLC (L2505, L2509). When the video signal having the horizontal frequency of 45 kHz ( $33.75 \text{ kHz} < F_h \leq 45 \text{ kHz}$ ), compensation is applied by L2509 and C2562. When the horizontal frequency of 30 kHz ( $15.75 \text{ kHz} < F_h \leq 33.75 \text{ kHz}$ ), compensation is applied by L2509, C2562 and C2563. When the horizontal frequency of 15 kHz ( $15.625 \text{ kHz} \leq F_h \leq 15.75 \text{ kHz}$ ), the relay RY2501 is turned off by Q2521 and compensation is applied by L2505, L2509, T2504 and C2562 to C2564. T2504 is a

choke coil that is inserted to raise the +B voltage during 15 kHz input mode. Q2519 is the switch to add the S-shape capacitor for 15 k and 30 k to the circuit, and is driven by Q2522 and Q2523. The control signal for switching these horizontal frequencies is supplied from IC2502 (D/A converter).

- **Vertical Output Circuit**

The vertical output circuit consists of IC2504 and its peripheral circuit.

The vertical output signal is generated by inputting the V. drive signal that is output from IC2503 pin-29, to IC2504 pin-1 where it is amplified. The V. center position is controlled by inputting the V. DC signal that is supplied from IC2503 pin-28, to IC2504 pin-7. The vertical deflection amplitude and the vertical center position are controlled by IC2503.

The vertical feedback pulse is generated by wave-shaping the V. flyback pulse with R3505, R3506 and D2524, and by inputting it to IC IC2503 pin-30.

- **H CENTER Circuit**

The H CENTER control is performed by converting the DC voltage level of IC2502 (D/A converter) pin-7 to electric current by IC2518, Q2516, amplified by IC2507, and by super-imposing an appropriate DC current upon the horizontal deflection current through L2504 (HCC). The power supply for IC2507 uses the floating power supplies that are HC+, HC- and HC N as described before.

- **Protector Circuit**

The D board (P2) has the three protectors that are H. PROT, V. PROT and H+B OVP. The H. PROT is the protector that is activated when the horizontal deflection is stopped. It detects existence of the collector pulse with IC2514, IC2515, D2519 and C576 after the collector pulse is divided by C2556 and C2557.

V. PROT is the protector that is activated when the vertical deflection is stopped. It detects existence of the V. out waveform after the V. out waveform is rectified and smoothed out by D2523 and C2578.

H+B OVP is the protector that is activated when the + B power voltage has increased by some defects. It detects the + B voltage after it is divided by R2552 and R2553. Operating point of the protector is about 65 V.

## 6-6. P Board

The P board consists of the PWM circuit for horizontal deflection system and for high voltage system, the + B power supply for high voltage output, protector circuit, degauss circuit and heater circuit.

### 1. PWM Circuit for Horizontal Deflection and High Voltage Systems

The PWM circuit for horizontal deflection system has already been described. The PWM circuit for high voltage system controls length of the ON period of the high voltage PWM output that is output from IC504 pin-13. The ON period is controlled by the error output that is obtained by comparing the reference voltage that is generated by the shunt regulator IC504 with the high voltage detected output that is output from FBT pin-12 which is the voltage obtained by dividing the high voltage (HV) with resistors.

For your reference, the input signal that is used as the reference of horizontal deflection and the high voltage systems is the HD signal that is output from IC2503 pin-21. The HD signal is locked to the input signal of the monitor. (When there is no input signal to the monitor, it synchronized with the free-run frequency.)

There can be a case that the horizontal output circuit and the high voltage output circuit are damaged because they cannot follow the sharp change of input frequency when frequency of the input signal is changed or when input channel is switched. In order to prevent the horizontal output circuit and the high voltage output circuit from damage, IC502 reduces the ON period of the horizontal and high voltage PWM output to their minimum (by decreasing the + B voltage so that the horizontal deflection size is reduced to minimum and high voltage is decreased to the lowest voltage) when IC502 receives the frequency change information from IC2503 pin-37 (DTC: Dead Time Control) in the D board. The ON period is controlled until these circuits are locked on the input frequency slowly with some time constant in order to prevent these circuits from damage.

IC502 also has the built-in HD drive output circuit that receives the HD input signal and is locked to the input HD frequency. Phase and ON time of the HD output signal is determined by the voltages that are applied to pin-22 and pin-21 respectively. In this monitor, this HD drive signal is also used as the drive signal of the high voltage output circuit.



## 2. + B Power Supply for High Voltage Output

The + B power supply for high voltage output consists of Q515, L501, D520, C535, C583 and other devices.

This circuit uses the step-up chopper circuit in order to produce the + B power in which the DC. IN input voltage is stepped up by switching the transistor Q515. When Q515 is turned on, a current flows from drain to source of Q515 through L501. When Q515 is turned off, a counter electromotive force is generated across L501 that charges C535 and C583 through D520 and generates the +B voltage. Relationship between DC. IN and +B voltage is shown below.

$$V (+B) = DC. IN + V (L501)$$

It means that the output voltage can be changed in accordance with the amount of energy that is stored in L501. In the other words, the output voltage can be controlled by controlling the ON time of Q515.

The +B power for the horizontal deflection system is controlled by the PWM IC IC502.

The PWM control signal (HV +B PWM) is output from IC502 pin-13. The PWM control output signal is amplified by Q506, Q509 and Q510, then is sent to Q515 gate.

## 3. High Voltage Output Circuit

The input drive signal to the high voltage output circuit is output from IC502 pin-23 and is sent to an input of the NAND gate IC505. The other input terminal of the NAND gate is the protector detection terminal (staying at the “L” level when the protector works) that cuts off the drive signal to the high voltage circuit when the protector works. The drive signal that is output from IC505 is sent to the HV OUT: Q520 gate through the inverter (Q511) and the drive circuit (Q513, Q514).

The flyback pulse is generated at the Q520 drain by the resonance of T502 (FBT), T501, C539, C542 when Q520 is switched and is turned off by the HV. DRV pulse.

As the CRT current increases and the high tension voltage decreases, the voltage at the high tension voltage detection pin pin-12 of FBT decreases so that Q515's ON time is prolonged by IC502. As the result of the longer ON time, +B voltage increases, the Q520 drain pulse becomes larger and the high tension voltage increases. The high tension voltage is thus regulated.

Q527 is the switch that selects the resonance capacitors.

The switch Q527 is turned on and capacitance of the resonance capacitor is increased when 15 kHz signal is input by shorting C542. This shorting is performed in order to stabilize the high voltage circuit by widening the pulse width of the drain pulse.

T502 is the flyback transformer that generates the high

tension voltage of the monitor, focus voltage, G2 voltage, heater voltage and high voltage protector detected output voltage. The circuit consisting of L504, C544 and R581 is the filter circuit in order to absorb the FBT damping. For your reference, the filter side of C545 that is T501 pin-2 receives the voltage that is equivalent to the + B voltage. The 120 V power voltage that is used for VIDEO OUT is generated by retracing and rectifying the voltage generated across the secondary winding of T501.

## 4. Protector Circuits

The P board has the following protector circuits that hold down the horizontal deflection circuit and the high voltage output circuit when any of the protector circuit is activated.

### • HV Protector

The HV protector is the circuit that holds down the high voltage when the high voltage (HV) that is applied to CRT exceeds the set value due to any abnormality or trouble.

The output signal from pin-5 of FBT that is the tertiary winding of FBT, is retrace-rectified by D527 and C554 to generated the detected output voltage of the high voltage protector. The high voltage output thus detected, is adjusted of its signal level, buffered by IC511 and is sent to the negative (-) input terminal of the comparator IC509 pin-3. The positive (+) input terminal of the comparator is connected to the reference voltage of the high voltage protector that is generated by the shunt regulator IC507. When the detected high voltage goes higher than the reference voltage, the comparator works so that the protector output terminal is latched to the “L” level by Q507 and Q508. The operating point of the HV protector is  $HV = 18.2 \text{ kV}$ .

### • Ik Protector

The Ik protector is the circuit that holds down the high voltage when the current Ik that flows through the CRT exceeds the set value due to any abnormality or trouble. The current flowing through the ABL signal line is detected in the form of voltage by the resistors R1504 to R1506. The detected current Ik is sent to the positive (+) input terminal of the comparator IC509 pin-5. The negative (-) input terminal of the comparator is connected to the reference voltage of the Ik protector that is generated by the voltage-division with R583 and R584. When the detected Ik voltage goes lower than the reference voltage, the comparator works so that the protector output terminal is latched to the “L” level by the circuit of Q521 to Q523. C538 is inserted in order to

pull up the Ik detection terminal to 12 V in order to prevent the protector circuit from erroneous operation. The operating point of the Ik protector is ABL current = 630  $\mu$ A.

- HV +B OCP Protector

The HV +B OCP protector is the circuit that holds down the high voltage when the current flowing through the DC. IN line exceeds the set value due to any abnormality or trouble.

The DC IN line voltage is voltage-divided by the resistors R1522 to R1524 that is sent to Q512 emitter.

The Q512 base receives the following voltage.

$$V_b(Q512) = DC. IN - R568 \times I(DC. IN) - V_f(D536)$$

When the relation of  $V_e - V_b \geq V_{be}(Q512)$  is established, Q512 turns on so that the protector output terminal is latched to the “L” level by the circuit of Q516 and Q519. D536 is inserted in order to cancel the temperature characteristics of the  $V_{be}$  voltage. The operating point of the HV +B OCP protector is I current (DC. IN) = about 2.4 [A].

- HV +B OVP Protector

The HV +B OVP protector is the circuit that holds down the high voltage when the HV +B line voltage exceeds the set value or when HV voltage abnormally decreases due to any abnormality or trouble.

The HV +B line voltage is voltage-divided by the resistors R1514 and R1513 to activate the protector. The operating point of the HV +B OVP protector is about 120 [V]. On the other hand, the detected output of the high voltage of the FBT is compared with the voltage level that is voltage-divided by R1532 and R1533 so that the abnormally low voltage from the FBT high voltage output can be detected in such a case of FBT layer short, and the protector is activated in such an error. However, this protector has a longer time constant that prevents the protector circuit from erroneous operation. The operating point of this protector is HV voltage  $\leq 6$  [kV].

- Degauss Circuit

The degauss circuit consists of the PWM controller IC503, the high withstand voltage FET driver IC506, the drive FET Q517 and the peripheral circuit.

When the main power is turned on or when the manual degauss is turned on, the control signal “DEGAUSS ON” that is sent to CN501 pin-8 is detected at its rise-up edge that sets “L” to IC503 DTC and to start oscillating the PWM output. (Length of the oscillating period is determined by the time constant of R518, R519 and

C518.) The signal that is output from IC503 pins-9 and -10 is sent to IC506 pins-10 and -12 to generate the signal that drives the FET in the subsequent circuit. The FET gate receives the signal that repeats High and Low only during the period when the PWM output is oscillating so that the FET is turned on and off repeatedly. When the FET is turned on, a current flows from the 120 V line to the degauss line so that the CRT is degaussed.

- Heater circuit

The heater circuit consists of the DC-DC converter IC510 and the peripheral circuit. The voltage that is obtained by rectifying the pin-8 “H1” using the FBT pin-7 output “H2” as the reference, is used as the power supply of IC510. The voltage that is obtained by rectifying the IC output with D530 and L505, is voltage-divided by resistors. The voltage that is obtained by the resistor-division is returned to IC510 as the feedback. The heater circuit uses the step-down converter circuit as its circuit configuration. The heater voltage that is applied to CRT is 4.5 Vrms.

## 6-7. HA, HB and HC boards

Key scan and turning on and off the LEDs

The SUB CPU (IC on the HC board) sends out the LED on signal and the key scan output signal using the serial signal (MISO, MOSI, SCLK). It receives the key scan input signal.

## 6-8. HD board

An input signal is selected from the various input signals that are connected to the AUDIO INPUT connectors (1, 2 and 3). It amplifies the selected audio signal and outputs the audio signal to speakers.

## Section 7 Semiconductors

**AN5265**

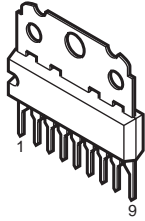

**BA05FP-E2**

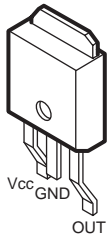

**BA05T  
BA09T**

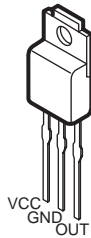

**CXA1211M  
CXA1521M  
LM358M  
LM393M  
LM393PS  
LTC490CS8  
M24C02-MN6T  
MAX487CSA-TE2  
MAX490ECSA  
MM1026BFB  
NJM2360AM (TE2)  
TC4W53FU  
TC7W08F  
TC7W32FU  
TC7W74FU  
TL082M  
UPC4558G2  
X25040SI**

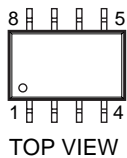

TOP VIEW

**CXA1544M-T6  
NJU3716M-T2**

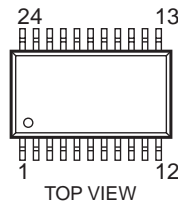

TOP VIEW

**CXA1739S**

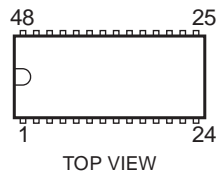

TOP VIEW

**CXA1875AM-T4  
MAX202CSE  
MAX3100CEE-TG068  
MC74HC4053F  
MC74HC4538AF  
TC74HC4053AFT (EL)  
TC74HC4538AF  
TL1451ACPWR  
TL494CNS**

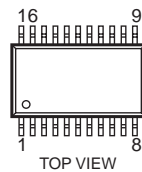

TOP VIEW

**HD6435368AX06M**

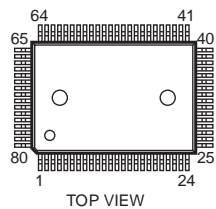

TOP VIEW

**IR2112  
SN74HC05ANS**

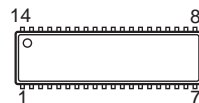

TOP VIEW

**LA6500-FA  
MC14052BF**

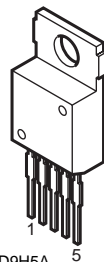

5

**LC35256DM-70-TLM  
MB90096PF-178  
MB90096PF-G-127-BND-ER**

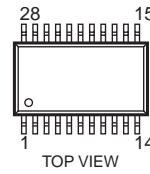

TOP VIEW

**LM2990SX-5.0**

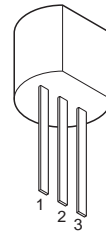

**LM2990T-5.0**



**M62399FP-TE2**

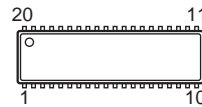

TOP VIEW

**MB89613R-651**



TOP VIEW

**MBM29F400BC-90PF**

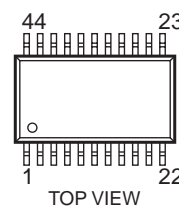

TOP VIEW

**MC74HC00AFEL  
MC74HC08AF  
MC74HC589AFEL  
TC74HC30AF  
TC74VHC02F  
TC74VHC04F  
TC74VHC125F  
TC74VHC138F  
TC74VHC14F**

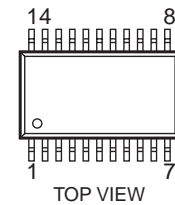

TOP VIEW

**MCR5102**

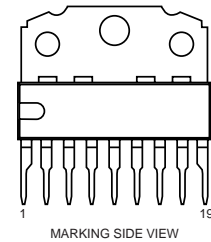

MARKING SIDE VIEW

**MZ1530**

MARKING SIDE VIEW

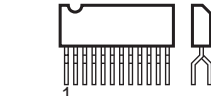

**PST529CMT**

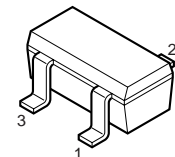

**SC7S02F  
TC-4S30F  
TC4S11F  
TC4S71F  
TC7S08F  
TC7S14F**

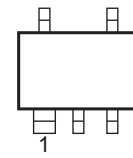

TOP VIEW

SE-012N

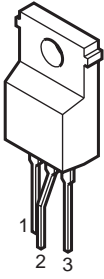

UPC1093J-1-T

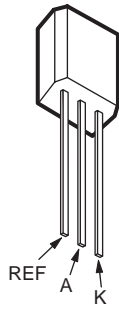

2SC4686A (LBSONY)  
2SD2578-CA  
IRFI640

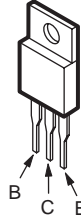

1SS119-25  
RD27ESB2  
RD5.1SB3-T2  
RD6.8SB2-T1  
RD7.5ESB1

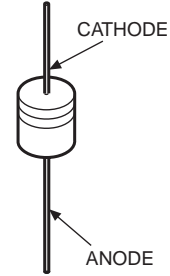

TC74VHC244F  
TC74VHC574F

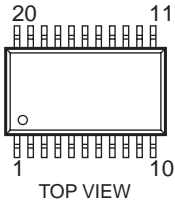

Z8622812PSC

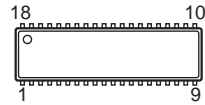

TOP VIEW

2SA1037AK-T146-QR  
2SA1037AK-T146-R  
2SA1330-06  
2SA1338-5-TB  
2SA1462-T1Y33  
2SA1462-Y33  
2SC1623-L5L6  
2SC3326N-A  
2SC3360-N16  
2SC3392-5-TB  
2SC3545-T43  
DTA114EKA-T146  
DTA144EKA-T146  
DTC114EK  
DTC114GKA  
DTC144EKA-T146

2SJ377 (TE16L)  
2SK2231-TP

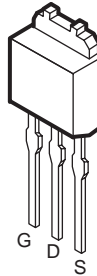

1SS226

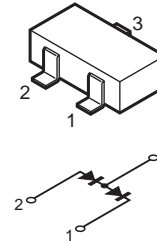

TDA6111Q/N4

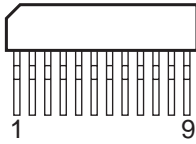

2SK520K44K45-T1B

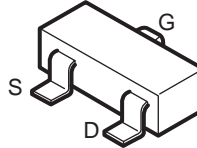

1SS352  
DTZ-TT11-5.6A  
RD12SB2  
RD18SB2-T1  
RD27SB-T1  
RD3.3SB  
RD6.2SB  
RD6.2SB2-T1

TDA8172

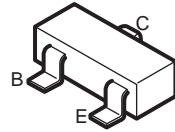
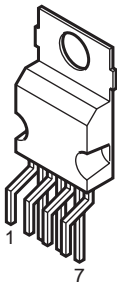

2SB1132-P  
2SD1834

IMT2

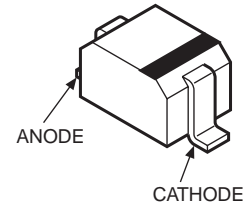
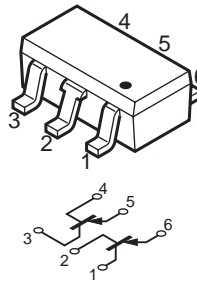

TDA9106

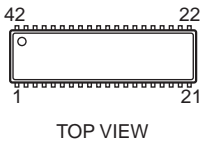

TOP VIEW

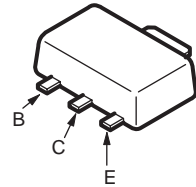

2SC2362K-G

IMX2-T109

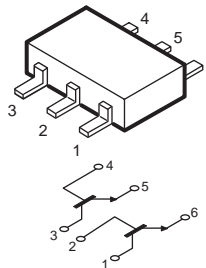

1SS83  
EL1Z  
RD12SB-T1

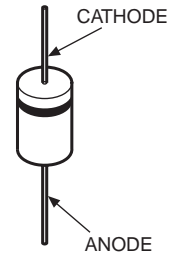

TL431CLP

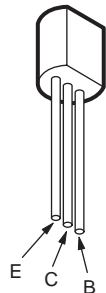
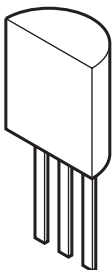

**D1NL20U-TR**  
**ERA91-02**

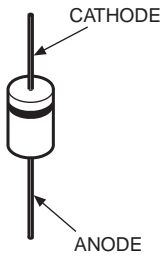

**DTZ-TT11-2.4B**

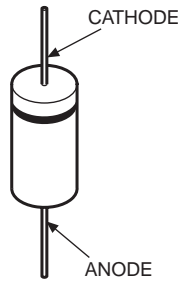

**RM11C**

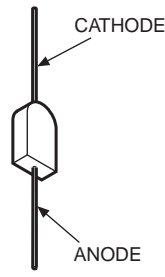

**D30SC4M**

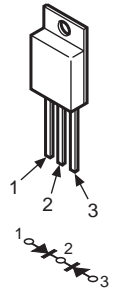

**EC10QS-06**  
**SC311-6-TE12RA**  
**SC802-04**  
**SC802-06**

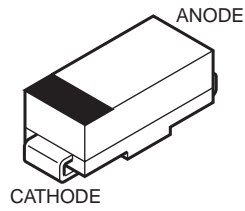

**SLR-325MCT31**  
**SLR-325VCT31**

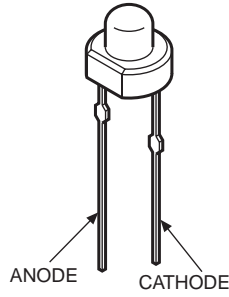

**D4SB60L**

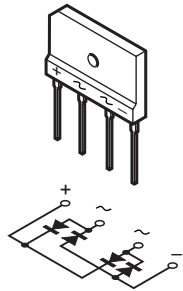

**MA111-(K8).S0**

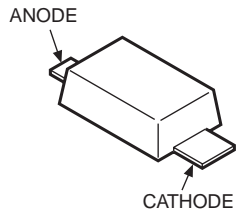

**SML-020MLTT87**

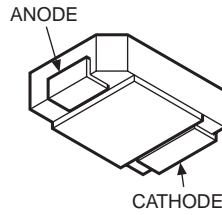

**D5L60**

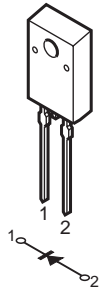

**RD10SB1**  
**RD4.7SB1-T1**  
**RD6.2SB (D9H5)**

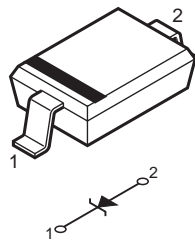

**RD18M-T1B2**  
**RD22M-B**

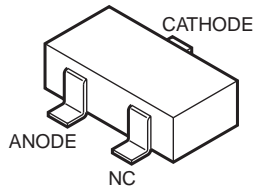



## Section 8 Exploded Views

**NOTE :**

The components identified marked  $\triangle$  are critical for safety. Replace only with the part number specified.

Les composants identifiés par la marque  $\triangle$  sont critiques pour la sécurité. Ne les remplacer que par une pièce portant le numéro spécifié.

- Items marked “\*” are not stocked since they are seldom required for routine service. Some delay should be anticipated when ordering these items.
- Items with no part number and no description are not stocked because they are seldom required for routine service.
- The construction parts of an assembled part are indicated with a collation number in the remarks column.

**Note:** In case the handle is defective, only handle can not be replaced. Replace the cabinet assy.

### 8-1. CHASSIS

- $\blacktriangle$ : 7-685-871-09 +BVTT 3x6
- $\triangle$ : 7-682-560-09 +B 4x6
- $\bullet$ : 7-682-903-21 +PWH 3x8
- $\square$ : 7-682-548-09 +B 3x8
- $\circ$ : 7-685-646-79 +BVTP 3x8
- $\blacktriangle$ : 7-682-548-04 +B 3x8
- $\oplus$ : 7-685-645-79 +BVTP 3x6

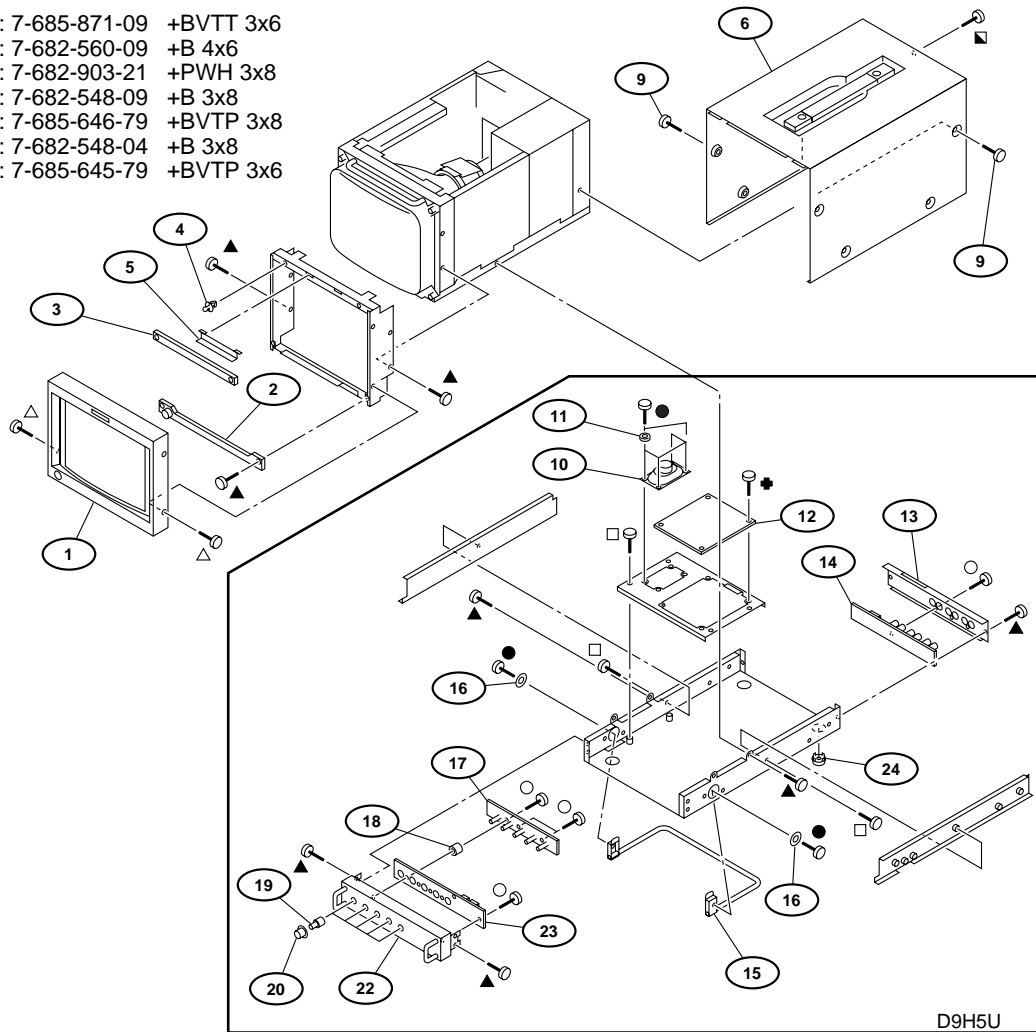

Ref.No.	Part No.	Description	Remark	Ref.No.	Part No.	Description	Remark
1	X-4037-176-1	BEZEL (16:9) ASSY		12	* A-1375-186-A	HC COMPL (D9H5)	
2	* A-1373-750-A	YB MOUNT		13	* 4-072-761-01	COVER, REAR (D9H5)	
3	* A-1373-751-A	YA MOUNT		14	* A-1372-677-A	HD MOUNT (D9H5)	
4	* 4-303-473-00	SUPPORT, PC		15	* X-4036-829-1	STAND ASSY (D9H5)	
5	* 4-073-708-01	PLATE, LIGHT INTERCEPTION		16	3-701-444-21	WASHER, 6 (D9H5)	
6	X-4037-295-2	CABINET ASSY (D9H1A, D9H1E)		17	* A-1372-676-A	HB MOUNT (D9H5)	
	X-4037-295-1	CABINET ASSY (D9H1U)		18	* 4-072-755-01	SPACER (D9H5)	
	X-4037-296-1	CABINET ASSY (D9H5U)		19	4-072-754-01	SHAFT (D9H5)	
	X-4037-296-2	CABINET ASSY (D9H5A, D9H5E)		20	4-072-756-01	BUTTON, VOLUME (D9H5)	
9	4-063-969-21	SCREW (OS), CASE, CLAW		22	X-4037-180-1	PANEL ASSY, CONTROL (D9H5)	
10	1-544-063-12	SPEAKER (D9H5)		23	* A-1372-675-A	HA MOUNT (D9H5)	
11	* 4-038-987-01	CUSHION, SPEAKER (D9H5)		24	* X-4037-179-1	FOOT ASSY (D9H5)	

8-2. PICTURE TUBE

- ▼: 7-682-946-09 +PSW 3x5
- : 7-682-948-09 +PSW 3x8
- ▲: 7-685-871-09 +BVTT 3x6
- ◇: 7-682-547-09 +B 3x6
- ▽: 7-627-556-58 +P 2.6x5

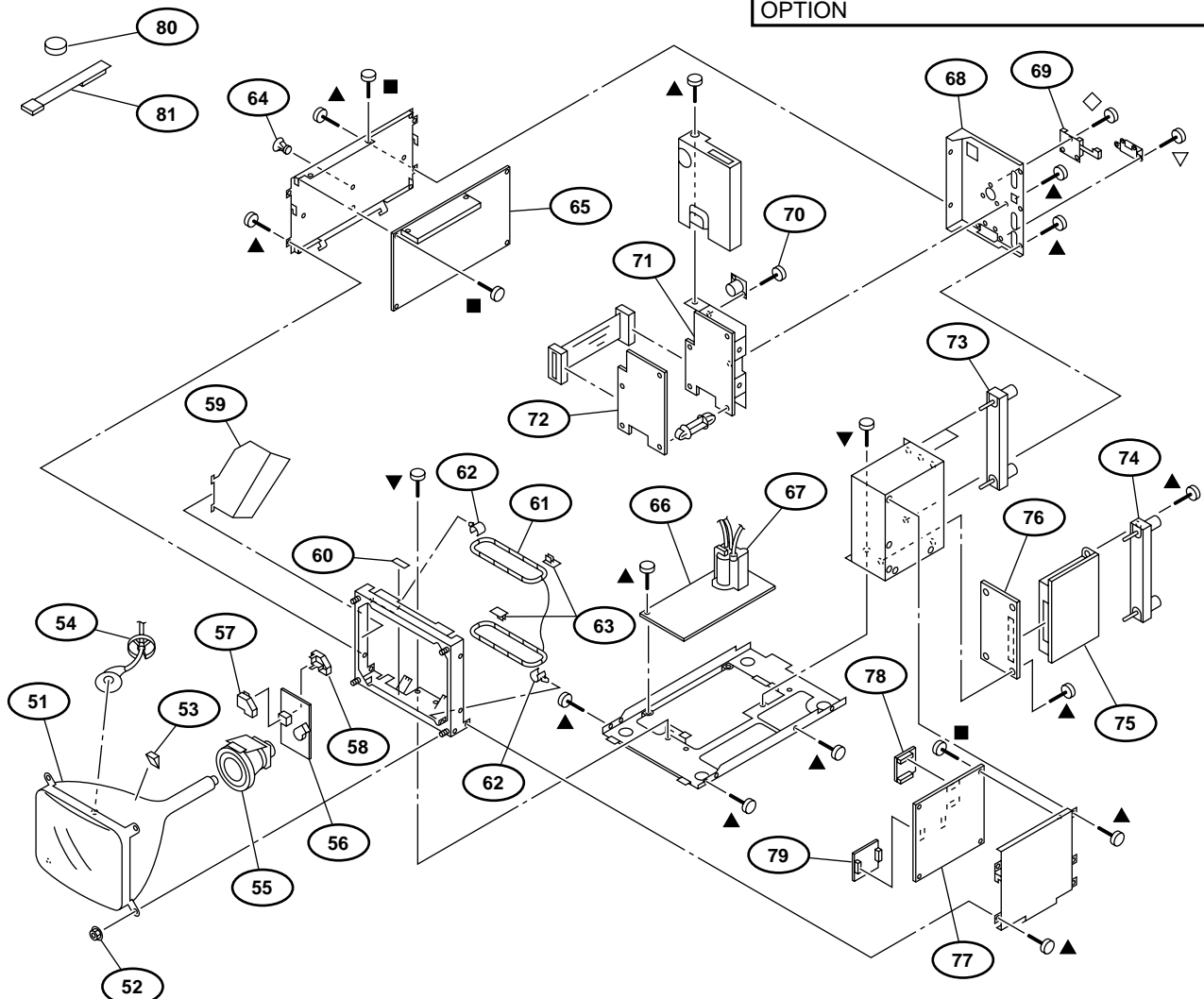
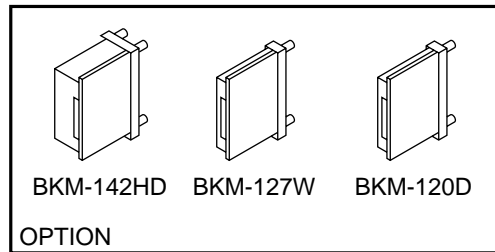

Ref.No.	Part No.	Description	Remark	Ref.No.	Part No.	Description	Remark
51	△ 8-737-658-05	PICTURE TUBE 09FX (DTV SPEC)		68	(* X-4037-178-1	PANEL ASSY, REAR (D9H1)	
52	4-304-511-00	NUT (M5), FLANGE			(* X-4037-178-2	PANEL ASSY, REAR (D9H5)	
53	4-309-369-00	SPACER, DEFLECTION YOKE		69	A-8278-025-C	MOUNT V ASSY	
54	* 4-034-856-01	HOLDER, HV CABLE		70	4-035-802-01	SCREW (M2.6X6)	
55	△ 1-451-507-11	DEFLECTION YOKE		71	(* A-1306-575-A	MB COMPL (D9H1)	
56	* A-1331-957-A	C MOUNT			(* A-1306-576-A	MB COMPL (D9H5)	
57	* 4-376-133-11	COVER (MAIN), CV VOL		72	(* A-1306-574-A	MA COMPL (D9H1)	
58	* 4-376-132-11	COVER (REAR LID), CV VOL			(* A-1306-581-A	MA COMPL (D9H5)	
59	* 4-073-712-01	INSULATOR (ANODE)		73	* X-4037-166-1	PANEL ASSY, BLANK	
60	3-840-486-02	CUSHION, SPEAKER		74	* X-4037-154-1	PANEL ASSY, CONNECTOR	
61	△ 1-419-306-11	COIL, DEGAUSSING		75	* A-1136-013-A	BX COMPL	
62	* 4-072-725-01	HOLDER, DEGAUSE COIL		76	* A-1390-942-A	T MOUNT	
63	4-380-534-01	CAP. DGC		77	* A-1136-024-A	B COMPL	78, 79
64	4-052-842-01	HOLDER, PWB		78	* A-1131-464-A	B2 MOUNT	
65	* A-1335-118-A	D COMPL		79	* A-1131-463-A	B1 MOUNT	
66	* A-1195-156-A	P COMPL	67	80	* 1-452-884-11	MAGNET	
67	△ 1-439-526-21	TRANSFORMER ASSY, FLYBACK		81	4-051-735-22	PIECE A(75), CONV. CORRECT	



## 8-3. POWER UNIT

- ◆: 7-682-549-09 +B 3x10  
 ☆: 7-682-247-09 +K 3x6  
 ◎: 7-682-961-01 +PSW 4x8  
 ▽: 7-627-556-58 +P 2.6x5

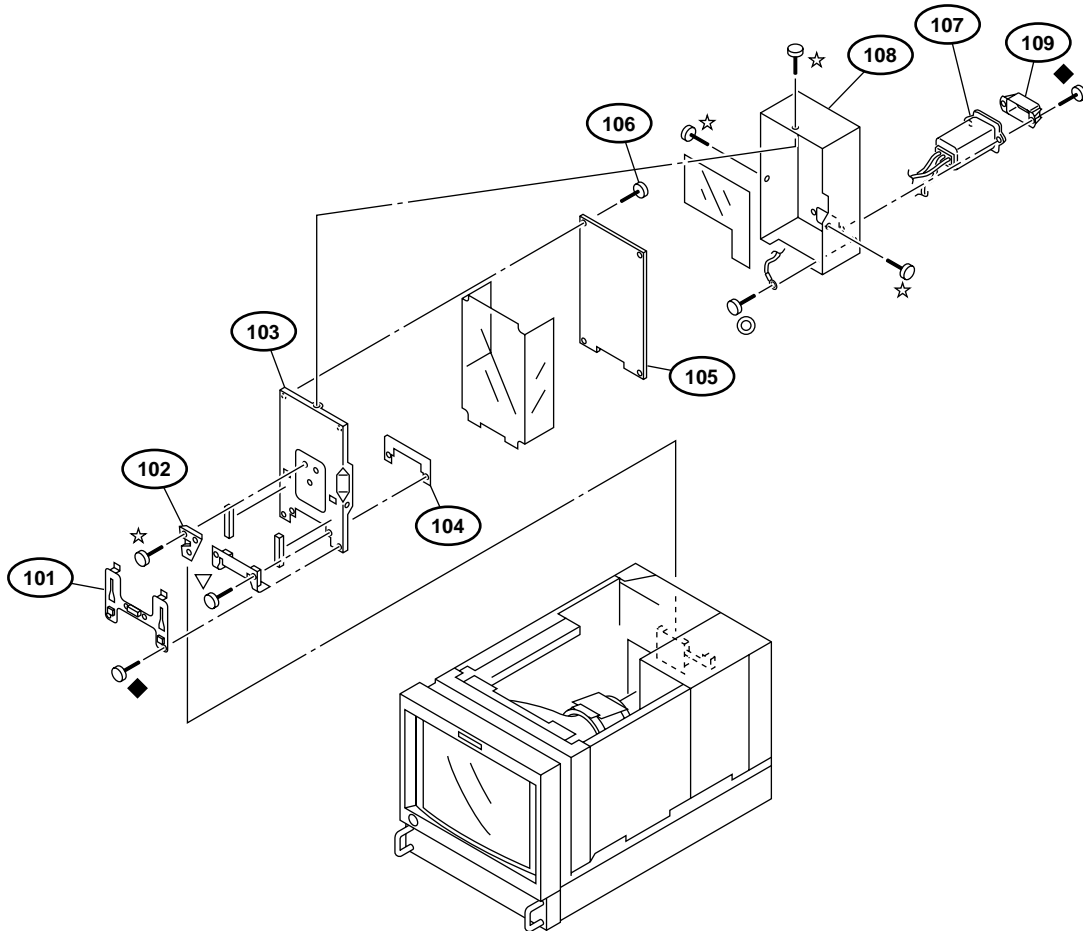

Ref.No.	Part No.	Description	Remark	Ref.No.	Part No.	Description	Remark
101	4-072-743-01	BRACKET, POWER					
102	* 4-628-904-02	SHOE, V					
103	* X-4037-169-1	CASE (BOTTOM) ASSY, POWER					
104	4-072-700-01	NUT, PLATE					
105	* A-1316-460-A	G COMPL					
106	4-382-854-01	SCREW (M3X8), P, SW (+)					
107	△ 1-251-382-11	INLET, AC 3P(WITH NOISE FILTER)					
108	* X-4037-170-1	CASE (TOP) ASSY, POWER					
109	2-990-241-02	HOLDER (A), PLUG					



## Section 9 Electrical Parts List

**NOTE :**

The components identified marked  $\triangle$  are critical for safety.  
Replace only with the part number specified.

Les composants identifiés par la marque  $\triangle$  sont critiques pour la sécurité.  
Ne les remplacer que par une pièce portant le numéro spécifié.

- Items marked “ \* ” are not stocked since they are seldom required for routine service. Some delay should be anticipated when ordering these items.
- Due to standardization, replacements in the parts list may be different from the parts specified in the diagrams or the components used on the set.

**RESISTORS**

- All resistors are in ohms.
- F: nonflammable
- METAL: Metal-film resistor
- METAL OXIDE: Metal oxide-film resistor

Ref.No.	Part No.	Description	Remark	Ref.No.	Part No.	Description	Remark
	* A-1136-024-A	B COMPL *****		C454	1-126-396-11	ELECT CHIP 47 $\mu$ F	20% 16V
	7-682-947-01	SCREW +PSW 3X6		C460	1-126-390-11	ELECT CHIP 22 $\mu$ F	20% 6.3V
	<CAPACITOR>			C461	1-126-390-11	ELECT CHIP 22 $\mu$ F	20% 6.3V
C300	1-163-031-11	CERAMIC CHIP 0.01 $\mu$ F	50V	C462	1-163-031-11	CERAMIC CHIP 0.01 $\mu$ F	50V
C301	1-163-031-11	CERAMIC CHIP 0.01 $\mu$ F	50V	C463	1-163-031-11	CERAMIC CHIP 0.01 $\mu$ F	50V
C304	1-104-760-11	CERAMIC CHIP 0.047 $\mu$ F	10% 50V	C464	1-163-031-11	CERAMIC CHIP 0.01 $\mu$ F	50V
C305	1-163-021-91	CERAMIC CHIP 0.01 $\mu$ F	10% 50V	C465	1-126-394-11	ELECT CHIP 10 $\mu$ F	20% 16V
C306	1-163-031-11	CERAMIC CHIP 0.01 $\mu$ F	50V	C466	1-126-394-11	ELECT CHIP 10 $\mu$ F	20% 16V
C307	1-164-505-11	CERAMIC CHIP 2.2 $\mu$ F	16V	C467	1-163-031-11	CERAMIC CHIP 0.01 $\mu$ F	50V
C308	1-115-152-11	ELECT CHIP 22 $\mu$ F	20% 6.3V	C468	1-163-031-11	CERAMIC CHIP 0.01 $\mu$ F	50V
C309	1-163-031-11	CERAMIC CHIP 0.01 $\mu$ F	50V	C485	1-126-390-11	ELECT CHIP 22 $\mu$ F	20% 6.3V
C310	1-163-031-11	CERAMIC CHIP 0.01 $\mu$ F	50V	C486	1-126-390-11	ELECT CHIP 22 $\mu$ F	20% 6.3V
C311	1-163-031-11	CERAMIC CHIP 0.01 $\mu$ F	50V	C487	1-163-031-11	CERAMIC CHIP 0.01 $\mu$ F	50V
C312	1-126-390-11	ELECT CHIP 22 $\mu$ F	20% 6.3V	C488	1-163-031-11	CERAMIC CHIP 0.01 $\mu$ F	50V
C332	1-104-760-11	CERAMIC CHIP 0.047 $\mu$ F	10% 50V	C489	1-163-031-11	CERAMIC CHIP 0.01 $\mu$ F	50V
C333	1-163-021-91	CERAMIC CHIP 0.01 $\mu$ F	10% 50V	C490	1-126-394-11	ELECT CHIP 10 $\mu$ F	20% 16V
C334	1-163-031-11	CERAMIC CHIP 0.01 $\mu$ F	50V	C491	1-163-031-11	CERAMIC CHIP 0.01 $\mu$ F	50V
C335	1-164-505-11	CERAMIC CHIP 2.2 $\mu$ F	16V	C492	1-163-031-11	CERAMIC CHIP 0.01 $\mu$ F	50V
C336	1-163-031-11	CERAMIC CHIP 0.01 $\mu$ F	50V	C494	1-126-396-11	ELECT CHIP 47 $\mu$ F	20% 16V
C337	1-163-031-11	CERAMIC CHIP 0.01 $\mu$ F	50V	C1300	1-163-031-11	CERAMIC CHIP 0.01 $\mu$ F	50V
C338	1-115-152-11	ELECT CHIP 22 $\mu$ F	20% 6.3V	C1301	1-163-031-11	CERAMIC CHIP 0.01 $\mu$ F	50V
C339	1-164-505-11	CERAMIC CHIP 2.2 $\mu$ F	16V	C1302	1-163-227-91	CERAMIC CHIP 10PF	0.5PF 50V
C340	1-163-031-11	CERAMIC CHIP 0.01 $\mu$ F	50V	C1304	1-104-760-11	CERAMIC CHIP 0.047 $\mu$ F	10% 50V
C341	1-163-031-11	CERAMIC CHIP 0.01 $\mu$ F	50V	C1305	1-163-021-91	CERAMIC CHIP 0.01 $\mu$ F	10% 50V
C367	1-104-760-11	CERAMIC CHIP 0.047 $\mu$ F	10% 50V	C1306	1-109-982-11	CERAMIC CHIP 1 $\mu$ F	10% 10V
C368	1-163-021-91	CERAMIC CHIP 0.01 $\mu$ F	10% 50V	C1307	1-163-031-11	CERAMIC CHIP 0.01 $\mu$ F	50V
C369	1-163-031-11	CERAMIC CHIP 0.01 $\mu$ F	50V	C1308	1-163-031-11	CERAMIC CHIP 0.01 $\mu$ F	50V
C370	1-164-505-11	CERAMIC CHIP 2.2 $\mu$ F	16V	C1309	1-164-505-11	CERAMIC CHIP 2.2 $\mu$ F	16V
C371	1-163-031-11	CERAMIC CHIP 0.01 $\mu$ F	50V	C1320	1-163-031-11	CERAMIC CHIP 0.01 $\mu$ F	50V
C372	1-163-031-11	CERAMIC CHIP 0.01 $\mu$ F	50V	C1321	1-163-031-11	CERAMIC CHIP 0.01 $\mu$ F	50V
C373	1-115-152-11	ELECT CHIP 22 $\mu$ F	20% 6.3V	C1322	1-163-227-91	CERAMIC CHIP 10PF	0.5PF 50V
C374	1-164-505-11	CERAMIC CHIP 2.2 $\mu$ F	16V	C1324	1-104-760-11	CERAMIC CHIP 0.047 $\mu$ F	10% 50V
C375	1-163-031-11	CERAMIC CHIP 0.01 $\mu$ F	50V	C1325	1-163-021-91	CERAMIC CHIP 0.01 $\mu$ F	10% 50V
C376	1-163-031-11	CERAMIC CHIP 0.01 $\mu$ F	50V	C1326	1-163-031-11	CERAMIC CHIP 0.01 $\mu$ F	50V
C377	1-126-396-11	ELECT CHIP 47 $\mu$ F	20% 16V	C1327	1-163-031-11	CERAMIC CHIP 0.01 $\mu$ F	50V
C378	1-126-396-11	ELECT CHIP 47 $\mu$ F	20% 16V	C1327	1-163-031-11	CERAMIC CHIP 0.01 $\mu$ F	50V
C386	1-126-916-11	ELECT 1000 $\mu$ F	20% 6.3V	C1330	1-164-346-91	CERAMIC CHIP 1 $\mu$ F	16V
C387	1-126-916-11	ELECT 1000 $\mu$ F	20% 6.3V	C1340	1-163-031-11	CERAMIC CHIP 0.01 $\mu$ F	50V
C450	1-126-394-11	ELECT CHIP 10 $\mu$ F	20% 16V	C1341	1-163-031-11	CERAMIC CHIP 0.01 $\mu$ F	50V
C451	1-163-031-11	CERAMIC CHIP 0.01 $\mu$ F	50V	C1342	1-163-227-91	CERAMIC CHIP 10PF	0.5PF 50V
C452	1-163-031-11	CERAMIC CHIP 0.01 $\mu$ F	50V	C1344	1-104-760-11	CERAMIC CHIP 0.047 $\mu$ F	10% 50V
				C1345	1-163-021-91	CERAMIC CHIP 0.01 $\mu$ F	10% 50V
				C1346	1-163-031-11	CERAMIC CHIP 0.01 $\mu$ F	50V
				C1347	1-163-031-11	CERAMIC CHIP 0.01 $\mu$ F	50V
				C1348	1-163-251-11	CERAMIC CHIP 100PF	5% 50V

Ref.No.	Part No.	Description	Remark	Ref.No.	Part No.	Description	Remark
C1400	1-163-035-00	CERAMIC CHIP 0.047μF	50V	C2370	1-107-746-11	ELECT 10μF	20% 200V
C1401	1-163-035-00	CERAMIC CHIP 0.047μF	50V	C2371	1-163-021-91	CERAMIC CHIP 0.01μF	10% 50V
C1402	1-163-035-00	CERAMIC CHIP 0.047μF	50V	C2372	1-163-021-91	CERAMIC CHIP 0.01μF	10% 50V
C1404	1-163-031-11	CERAMIC CHIP 0.01μF	50V	C2373	1-163-021-91	CERAMIC CHIP 0.01μF	10% 50V
C1405	1-163-035-00	CERAMIC CHIP 0.047μF	50V	C2374	1-126-394-11	ELECT CHIP 10μF	20% 16V
C1406	1-163-809-11	CERAMIC CHIP 0.047μF	10% 25V	C2375	1-126-394-11	ELECT CHIP 10μF	20% 16V
C1407	1-163-809-11	CERAMIC CHIP 0.047μF	10% 25V	C2376	1-126-394-11	ELECT CHIP 10μF	20% 16V
C1408	1-163-809-11	CERAMIC CHIP 0.047μF	10% 25V	C2380	1-163-005-11	CERAMIC CHIP 470PF	10% 50V
C1409	1-164-489-11	CERAMIC CHIP 0.22μF	10% 16V	C2381	1-163-005-11	CERAMIC CHIP 470PF	10% 50V
C1410	1-164-004-91	CERAMIC CHIP 0.1μF	10% 25V	C2382	1-163-005-11	CERAMIC CHIP 470PF	10% 50V
C1411	1-164-004-91	CERAMIC CHIP 0.1μF	10% 25V	C2383	1-163-031-11	CERAMIC CHIP 0.01μF	50V
C1412	1-164-004-91	CERAMIC CHIP 0.1μF	10% 25V	C2384	1-163-009-11	CERAMIC CHIP 0.001μF	10% 50V
C1413	1-163-251-11	CERAMIC CHIP 100PF	5% 50V	C2385	1-163-009-11	CERAMIC CHIP 0.001μF	10% 50V
C1414	1-163-275-11	CERAMIC CHIP 0.001μF	5% 50V	C2386	1-163-031-11	CERAMIC CHIP 0.01μF	50V
C1415	1-163-038-91	CERAMIC CHIP 0.1μF	25V	C2387	1-163-031-11	CERAMIC CHIP 0.01μF	50V
C1416	1-164-004-91	CERAMIC CHIP 0.1μF	10% 25V	C2388	1-163-031-11	CERAMIC CHIP 0.01μF	50V
C1417	1-164-004-91	CERAMIC CHIP 0.1μF	10% 25V	C2389	1-163-031-11	CERAMIC CHIP 0.01μF	50V
C1418	1-164-004-91	CERAMIC CHIP 0.1μF	10% 25V	C2390	1-163-031-11	CERAMIC CHIP 0.01μF	50V
C1419	1-163-251-11	CERAMIC CHIP 100PF	5% 50V	C3301	1-126-394-11	ELECT CHIP 10μF	20% 16V
C1420	1-163-275-11	CERAMIC CHIP 0.001μF	5% 50V	C3302	1-163-251-11	CERAMIC CHIP 100PF	5% 50V
C1421	1-163-038-91	CERAMIC CHIP 0.1μF	25V	C3303	1-163-251-11	CERAMIC CHIP 100PF	5% 50V
C1422	1-164-004-91	CERAMIC CHIP 0.1μF	10% 25V	C3304	1-163-257-11	CERAMIC CHIP 180PF	5% 50V
C1423	1-164-004-91	CERAMIC CHIP 0.1μF	10% 25V	C3305	1-163-251-11	CERAMIC CHIP 100PF	5% 50V
C1424	1-163-251-11	CERAMIC CHIP 100PF	5% 50V	C3306	1-163-257-11	CERAMIC CHIP 180PF	5% 50V
C1425	1-163-275-11	CERAMIC CHIP 0.001μF	5% 50V	C3307	1-163-251-11	CERAMIC CHIP 100PF	5% 50V
C1426	1-163-038-91	CERAMIC CHIP 0.1μF	25V	C3308	1-164-346-11	CERAMIC CHIP 1μF	16V
C1427	1-163-038-91	CERAMIC CHIP 0.1μF	25V	C3309	1-126-390-11	ELECT CHIP 22μF	20% 6.3V
C1428	1-164-004-91	CERAMIC CHIP 0.1μF	10% 25V	C3311	1-163-038-91	CERAMIC CHIP 0.1μF	25V
C1429	1-163-038-91	CERAMIC CHIP 0.1μF	25V	C3312	1-163-038-91	CERAMIC CHIP 0.1μF	25V
C1430	1-126-390-11	ELECT CHIP 22μF	20% 6.3V	C3313	1-163-263-11	CERAMIC CHIP 330PF	5% 50V
C1431	1-163-005-11	CERAMIC CHIP 470PF	10% 50V	C3314	1-163-038-91	CERAMIC CHIP 0.1μF	25V
C1450	1-163-031-11	CERAMIC CHIP 0.01μF	50V	C3316	1-163-038-91	CERAMIC CHIP 0.1μF	25V
C1451	1-163-251-11	CERAMIC CHIP 100PF	5% 50V	C3332	1-163-031-11	CERAMIC CHIP 0.01μF	50V
C1460	1-164-005-11	CERAMIC CHIP 0.47μF	25V	C3333	1-163-031-11	CERAMIC CHIP 0.01μF	50V
C1461	1-163-031-11	CERAMIC CHIP 0.01μF	50V	C3339	1-163-031-11	CERAMIC CHIP 0.01μF	50V
C1462	1-163-031-11	CERAMIC CHIP 0.01μF	50V	C3341	1-163-251-11	CERAMIC CHIP 100PF	5% 50V
C1464	1-164-005-11	CERAMIC CHIP 0.47μF	25V	C3344	1-164-004-11	CERAMIC CHIP 0.1μF	10% 25V
C1465	1-163-031-11	CERAMIC CHIP 0.01μF	50V	C3350	1-164-005-11	CERAMIC CHIP 0.47μF	25V
C1466	1-163-031-11	CERAMIC CHIP 0.01μF	50V	C3402	1-163-031-11	CERAMIC CHIP 0.01μF	50V
C1467	1-126-935-11	ELECT 470μF	20% 16V	C3403	1-163-031-11	CERAMIC CHIP 0.01μF	50V
C1468	1-126-396-11	ELECT CHIP 47μF	20% 16V	C3405	1-163-038-91	CERAMIC CHIP 0.1μF	25V
C1469	1-126-396-11	ELECT CHIP 47μF	20% 16V	C3406	1-164-182-11	CERAMIC CHIP 0.0033μF	10% 50V
C2310	1-126-396-11	ELECT CHIP 47μF	20% 16V	C3407	1-164-344-11	CERAMIC CHIP 0.068μF	10% 25V
C2311	1-163-031-11	CERAMIC CHIP 0.01μF	50V	C3408	1-126-394-11	ELECT CHIP 10μF	20% 16V
C2345	1-163-031-11	CERAMIC CHIP 0.01μF	50V	C3410	1-164-004-11	CERAMIC CHIP 0.1μF	10% 25V
C2346	1-163-220-11	CERAMIC CHIP 3PF	0.25PF 50V	C3411	1-163-259-91	CERAMIC CHIP 220PF	5% 50V
C2347	1-107-364-11	MYLAR 0.01μF	10% 200V	C3412	1-164-004-11	CERAMIC CHIP 0.1μF	10% 25V
C2348	1-163-251-11	CERAMIC CHIP 100PF	5% 50V	C3432	1-163-035-00	CERAMIC CHIP 0.047μF	50V
C2350	1-107-746-11	ELECT 10μF	20% 200V	C3433	1-163-031-11	CERAMIC CHIP 0.01μF	50V
C2351	1-163-031-11	CERAMIC CHIP 0.01μF	50V	C4300	1-163-031-11	CERAMIC CHIP 0.01μF	50V
C2352	1-163-031-11	CERAMIC CHIP 0.01μF	50V	C4302	1-163-031-11	CERAMIC CHIP 0.01μF	50V
C2353	1-163-031-11	CERAMIC CHIP 0.01μF	50V	C4303	1-163-031-11	CERAMIC CHIP 0.01μF	50V
C2355	1-163-031-11	CERAMIC CHIP 0.01μF	50V	C4350	1-163-031-11	CERAMIC CHIP 0.01μF	50V
C2356	1-163-087-00	CERAMIC CHIP 4PF	0.25PF 50V	C4351	1-163-031-11	CERAMIC CHIP 0.01μF	50V
C2357	1-107-364-11	MYLAR 0.01μF	10% 200V	C4352	1-163-031-11	CERAMIC CHIP 0.01μF	50V
C2358	1-163-251-11	CERAMIC CHIP 100PF	5% 50V	C4353	1-163-031-11	CERAMIC CHIP 0.01μF	50V
C2360	1-107-746-11	ELECT 10μF	20% 200V	C4354	1-163-031-11	CERAMIC CHIP 0.01μF	50V
C2361	1-126-396-11	ELECT CHIP 47μF	20% 16V	C4355	1-126-396-11	ELECT CHIP 47μF	20% 16V
C2362	1-163-031-11	CERAMIC CHIP 0.01μF	50V	<CONNECTOR>			
C2363	1-126-396-11	ELECT CHIP 47μF	20% 16V	CN301	1-764-334-11	PLUG, CONNECTOR 11P	
C2364	1-163-031-11	CERAMIC CHIP 0.01μF	50V	CN302	* 1-564-511-11	PLUG, CONNECTOR 8P	
C2365	1-163-031-11	CERAMIC CHIP 0.01μF	50V	CN303	* 1-564-510-11	PLUG, CONNECTOR 7P	
C2366	1-163-087-00	CERAMIC CHIP 4PF	0.25PF 50V	CN305	* 1-564-509-11	PLUG, CONNECTOR 6P	
C2367	1-107-364-11	MYLAR 0.01μF	10% 200V	CN307	* 1-564-512-11	PLUG, CONNECTOR 9P	
C2368	1-163-251-11	CERAMIC CHIP 100PF	5% 50V				

Ref.No.	Part No.	Description	Remark	Ref.No.	Part No.	Description	Remark
CN308	* 1-564-512-11	PLUG, CONNECTOR 9P		IC3400	8-759-424-13	IC MC74HC00AFEL	
CN411	* 1-506-611-11	PIN, CONNECTOR 8P		IC3401	8-759-032-14	IC MC74HC08AF	
CN412	* 1-506-611-11	PIN, CONNECTOR 8P		IC3403	8-759-328-12	IC Z8622812PSC	
CN421	* 1-779-070-21	PIN, CONNECTOR 12P		IC3404	8-759-527-74	IC M24C02-MN6T	
CN422	* 1-779-070-21	PIN, CONNECTOR 12P		IC3406	8-759-084-79	IC TC7S14F	
		<DIODE>					
D1400	8-719-073-01	DIODE MA111-(K8).S0		IC3407	8-759-242-76	IC TC7W08F	
D1401	8-719-073-01	DIODE MA111-(K8).S0		IC4300	8-752-072-94	IC CXA1875AM-T4	
D1402	8-719-073-01	DIODE MA111-(K8).S0		IC4301	8-752-072-94	IC CXA1875AM-T4	
D1403	8-719-073-01	DIODE MA111-(K8).S0		IC4302	8-752-072-94	IC CXA1875AM-T4	
D1404	8-719-037-17	DIODE RD10SB3-T1		IC4350	8-752-072-94	IC CXA1875AM-T4	
D1405	8-719-073-01	DIODE MA111-(K8).S0		IC4351	8-759-482-47	IC M62399FP-TE2	
D2345	8-719-157-72	DIODE RD22M-B		IC4352	8-759-482-47	IC M62399FP-TE2	
D2346	8-719-901-83	DIODE 1SS83				<COIL>	
D2347	8-719-901-83	DIODE 1SS83		L300	1-406-669-11	INDUCTOR 470µH	
D2348	8-719-073-01	DIODE MA111-(K8).S0				<TRANSISTOR>	
D2349	8-719-073-01	DIODE MA111-(K8).S0		Q300	8-729-112-65	TRANSISTOR 2SA1462-Y33	
D2355	8-719-157-72	DIODE RD22M-B		Q301	8-729-107-31	TRANSISTOR 2SC3545-T43	
D2356	8-719-901-83	DIODE 1SS83		Q302	8-729-920-59	TRANSISTOR IMX2-T109	
D2357	8-719-901-83	DIODE 1SS83		Q303	8-729-120-28	TRANSISTOR 2SC1623-L5L6	
D2358	8-719-073-01	DIODE MA111-(K8).S0		Q304	8-729-120-28	TRANSISTOR 2SC1623-L5L6	
D2359	8-719-073-01	DIODE MA111-(K8).S0		Q330	8-729-112-65	TRANSISTOR 2SA1462-Y33	
D2365	8-719-157-72	DIODE RD22M-B		Q331	8-729-107-31	TRANSISTOR 2SC3545-T43	
D2366	8-719-901-83	DIODE 1SS83		Q332	8-729-920-59	TRANSISTOR IMX2-T109	
D2367	8-719-901-83	DIODE 1SS83		Q333	8-729-120-28	TRANSISTOR 2SC1623-L5L6	
D2369	8-719-073-01	DIODE MA111-(K8).S0		Q334	8-729-120-28	TRANSISTOR 2SC1623-L5L6	
D2370	8-719-073-01	DIODE MA111-(K8).S0		Q365	8-729-112-65	TRANSISTOR 2SA1462-Y33	
D3301	8-719-016-74	DIODE 1SS352		Q366	8-729-107-31	TRANSISTOR 2SC3545-T43	
D3302	8-719-016-74	DIODE 1SS352		Q367	8-729-920-59	TRANSISTOR IMX2-T109	
D3307	8-719-800-76	DIODE 1SS226		Q368	8-729-120-28	TRANSISTOR 2SC1623-L5L6	
D3308	8-719-800-76	DIODE 1SS226		Q369	8-729-120-28	TRANSISTOR 2SC1623-L5L6	
D4401	8-719-036-88	DIODE RD4.7SB1-T1		Q450	8-729-120-28	TRANSISTOR 2SC1623-L5L6	
		<IC>		Q451	8-729-107-31	TRANSISTOR 2SC3545-T43	
IC300	8-759-011-65	IC MC74HC4053F		Q452	8-729-120-28	TRANSISTOR 2SC1623-L5L6	
IC301	8-759-011-65	IC MC74HC4053F		Q453	8-729-112-65	TRANSISTOR 2SA1462-Y33	
IC302	8-759-011-65	IC MC74HC4053F		Q460	8-729-112-65	TRANSISTOR 2SA1462-Y33	
IC303	8-759-981-48	IC TL082M		Q461	8-729-107-31	TRANSISTOR 2SC3545-T43	
IC304	8-759-981-48	IC TL082M		Q462	8-729-120-28	TRANSISTOR 2SC1623-L5L6	
IC305	8-759-981-48	IC TL082M		Q463	8-729-107-31	TRANSISTOR 2SC3545-T43	
IC306	8-752-054-80	IC CXA1521M		Q464	8-729-120-28	TRANSISTOR 2SC1623-L5L6	
IC307	8-752-054-80	IC CXA1521M		Q465	8-729-026-50	TRANSISTOR 2SA1037AK-T146-QR	
IC308	8-752-054-80	IC CXA1521M		Q466	8-729-026-50	TRANSISTOR 2SA1037AK-T146-QR	
IC400	8-752-053-21	IC CXA1211M		Q485	8-729-120-28	TRANSISTOR 2SC1623-L5L6	
IC401	8-752-053-21	IC CXA1211M		Q486	8-729-107-31	TRANSISTOR 2SC3545-T43	
IC1300	8-759-011-65	IC MC74HC4053F		Q487	8-729-120-28	TRANSISTOR 2SC1623-L5L6	
IC1302	8-759-011-65	IC MC74HC4053F		Q1300	8-729-112-65	TRANSISTOR 2SA1462-Y33	
IC1303	8-759-011-65	IC MC74HC4053F		Q1301	8-729-107-31	TRANSISTOR 2SC3545-T43	
IC1304	8-759-011-65	IC MC74HC4053F		Q1302	8-729-120-28	TRANSISTOR 2SC1623-L5L6	
IC1305	8-759-981-48	IC TL082M		Q1303	8-729-120-28	TRANSISTOR 2SC1623-L5L6	
IC1306	8-759-981-48	IC TL082M		Q1304	8-729-120-28	TRANSISTOR 2SC1623-L5L6	
IC1307	8-759-981-48	IC TL082M		Q1305	8-729-026-50	TRANSISTOR 2SA1037AK-T146-QR	
IC1308	8-759-011-65	IC MC74HC4053F		Q1320	8-729-112-65	TRANSISTOR 2SA1462-Y33	
IC1309	8-759-011-65	IC MC74HC4053F		Q1321	8-729-107-31	TRANSISTOR 2SC3545-T43	
IC1400	8-759-038-15	IC MC74HC4538AF		Q1322	8-729-120-28	TRANSISTOR 2SC1623-L5L6	
IC1401	8-752-067-05	IC CXA1739S		Q1323	8-729-120-28	TRANSISTOR 2SC1623-L5L6	
IC2345	8-759-360-83	IC TDA6111Q/N4		Q1340	8-729-112-65	TRANSISTOR 2SA1462-Y33	
IC2355	8-759-360-83	IC TDA6111Q/N4		Q1341	8-729-107-31	TRANSISTOR 2SC3545-T43	
IC2365	8-759-360-83	IC TDA6111Q/N4		Q1342	8-729-120-28	TRANSISTOR 2SC1623-L5L6	
IC2380	8-759-523-02	IC TC74HC4053AFT(EL)		Q1343	8-729-120-28	TRANSISTOR 2SC1623-L5L6	
IC2381	8-759-523-02	IC TC74HC4053AFT(EL)		Q1400	1-801-806-11	TRANSISTOR DTC144EKA-T146	
IC2382	8-759-988-13	IC LM393PS		Q1401	8-729-120-28	TRANSISTOR 2SC1623-L5L6	
IC2383	8-759-083-94	IC TC7W74FU					
IC3301	8-759-523-02	IC TC74HC4053AFT(EL)					



Ref.No.	Part No.	Description	Remark	Ref.No.	Part No.	Description	Remark
Q1402	8-729-026-50	TRANSISTOR 2SA1037AK-T146-QR		R306	1-216-025-91	RES,CHIP 100	5% 1/10W
Q1410	8-729-026-50	TRANSISTOR 2SA1037AK-T146-QR		R307	1-216-653-11	METAL CHIP 1.2K	0.50% 1/10W
Q1411	8-729-120-28	TRANSISTOR 2SC1623-L5L6		R308	1-216-025-91	RES,CHIP 100	5% 1/10W
Q1412	8-729-026-50	TRANSISTOR 2SA1037AK-T146-QR		R309	1-216-049-91	RES,CHIP 1K	5% 1/10W
Q1413	8-729-120-28	TRANSISTOR 2SC1623-L5L6		R310	1-216-049-91	RES,CHIP 1K	5% 1/10W
Q1414	8-729-120-28	TRANSISTOR 2SC1623-L5L6		R311	1-216-029-00	RES,CHIP 150	5% 1/10W
Q1420	8-729-026-50	TRANSISTOR 2SA1037AK-T146-QR		R312	1-216-675-91	METAL CHIP 10K	0.50% 1/10W
Q1421	8-729-120-28	TRANSISTOR 2SC1623-L5L6		R313	1-218-776-11	METAL CHIP 1M	0.50% 1/10W
Q1422	8-729-026-50	TRANSISTOR 2SA1037AK-T146-QR		R314	1-216-675-91	METAL CHIP 10K	0.50% 1/10W
Q1423	8-729-120-28	TRANSISTOR 2SC1623-L5L6		R315	1-218-764-11	METAL CHIP 330K	0.50% 1/10W
Q1424	8-729-120-28	TRANSISTOR 2SC1623-L5L6		R316	1-216-033-00	RES,CHIP 220	5% 1/10W
Q1430	8-729-026-50	TRANSISTOR 2SA1037AK-T146-QR		R317	1-216-025-91	RES,CHIP 100	5% 1/10W
Q1431	8-729-120-28	TRANSISTOR 2SC1623-L5L6		R318	1-216-053-00	RES,CHIP 1.5K	5% 1/10W
Q1432	8-729-026-50	TRANSISTOR 2SA1037AK-T146-QR		R319	1-216-685-11	METAL CHIP 27K	0.50% 1/10W
Q1433	8-729-120-28	TRANSISTOR 2SC1623-L5L6		R320	1-216-679-11	METAL CHIP 15K	0.50% 1/10W
Q1434	8-729-120-28	TRANSISTOR 2SC1623-L5L6		R321	1-216-089-91	RES,CHIP 47K	5% 1/10W
Q1460	8-729-120-28	TRANSISTOR 2SC1623-L5L6		R322	1-216-681-11	METAL CHIP 18K	0.50% 1/10W
Q1461	8-729-120-28	TRANSISTOR 2SC1623-L5L6		R323	1-216-025-91	RES,CHIP 100	5% 1/10W
Q1463	8-729-900-53	TRANSISTOR DTC114EK		R324	1-216-057-00	RES,CHIP 2.2K	5% 1/10W
Q2303	8-729-026-50	TRANSISTOR 2SA1037AK-T146-QR		R325	1-216-037-00	RES,CHIP 330	5% 1/10W
Q2318	8-729-026-50	TRANSISTOR 2SA1037AK-T146-QR		R330	1-216-049-91	RES,CHIP 1K	5% 1/10W
Q2333	8-729-026-50	TRANSISTOR 2SA1037AK-T146-QR		R331	1-216-025-91	RES,CHIP 100	5% 1/10W
Q2345	8-729-033-31	TRANSISTOR 2SK520K44K45-T1B		R332	1-216-657-11	METAL CHIP 1.8K	0.50% 1/10W
Q2346	8-729-105-08	TRANSISTOR 2SA1330-06		R333	1-216-663-11	METAL CHIP 3.3K	0.50% 1/10W
Q2355	8-729-033-31	TRANSISTOR 2SK520K44K45-T1B		R335	1-216-651-11	METAL CHIP 1K	0.50% 1/10W
Q2356	8-729-105-08	TRANSISTOR 2SA1330-06		R336	1-216-025-91	RES,CHIP 100	5% 1/10W
Q2365	8-729-033-31	TRANSISTOR 2SK520K44K45-T1B		R337	1-216-653-11	METAL CHIP 1.2K	0.50% 1/10W
Q2366	8-729-105-08	TRANSISTOR 2SA1330-06		R338	1-216-025-91	RES,CHIP 100	5% 1/10W
Q2375	8-729-105-37	TRANSISTOR 2SC3360-N16		R339	1-216-049-91	RES,CHIP 1K	5% 1/10W
Q2375	8-729-105-37	TRANSISTOR 2SC3360-N16		R340	1-216-049-91	RES,CHIP 1K	5% 1/10W
Q2376	8-729-105-37	TRANSISTOR 2SC3360-N16		R341	1-216-025-91	RES,CHIP 100	5% 1/10W
Q2376	8-729-105-37	TRANSISTOR 2SC3360-N16		R342	1-216-675-91	METAL CHIP 10K	0.50% 1/10W
Q2377	8-729-105-37	TRANSISTOR 2SC3360-N16		R343	1-218-776-11	METAL CHIP 1M	0.50% 1/10W
Q2377	8-729-105-37	TRANSISTOR 2SC3360-N16		R344	1-216-675-91	METAL CHIP 10K	0.50% 1/10W
Q2380	8-729-120-28	TRANSISTOR 2SC1623-L5L6		R345	1-218-770-11	METAL CHIP 560K	0.50% 1/10W
Q2381	8-729-120-28	TRANSISTOR 2SC1623-L5L6		R346	1-216-033-00	RES,CHIP 220	5% 1/10W
Q2382	8-729-120-28	TRANSISTOR 2SC1623-L5L6		R347	1-216-025-91	RES,CHIP 100	5% 1/10W
Q2383	8-729-120-28	TRANSISTOR 2SC1623-L5L6		R348	1-216-053-00	RES,CHIP 1.5K	5% 1/10W
Q3301	8-729-026-50	TRANSISTOR 2SA1037AK-T146-QR		R349	1-216-683-11	METAL CHIP 22K	0.50% 1/10W
Q3302	8-729-026-50	TRANSISTOR 2SA1037AK-T146-QR		R350	1-218-759-11	METAL CHIP 200K	0.50% 1/10W
Q3303	8-729-026-50	TRANSISTOR 2SA1037AK-T146-QR		R351	1-216-693-11	METAL CHIP 56K	0.50% 1/10W
Q3304	8-729-920-59	TRANSISTOR IMX2-T109		R353	1-216-089-91	RES,CHIP 47K	5% 1/10W
Q3305	8-729-920-59	TRANSISTOR IMX2-T109		R354	1-216-025-91	RES,CHIP 100	5% 1/10W
Q3306	8-729-120-28	TRANSISTOR 2SC1623-L5L6		R355	1-216-057-00	RES,CHIP 2.2K	5% 1/10W
Q3307	8-729-026-50	TRANSISTOR 2SA1037AK-T146-QR		R356	1-216-033-00	RES,CHIP 220	5% 1/10W
Q3308	8-729-107-31	TRANSISTOR 2SC3545-T43		R365	1-216-049-91	RES,CHIP 1K	5% 1/10W
Q3309	8-729-120-28	TRANSISTOR 2SC1623-L5L6		R366	1-216-025-91	RES,CHIP 100	5% 1/10W
Q3310	8-729-925-42	TRANSISTOR IMT2		R367	1-216-657-11	METAL CHIP 1.8K	0.50% 1/10W
Q3311	8-729-120-28	TRANSISTOR 2SC1623-L5L6		R368	1-216-663-11	METAL CHIP 3.3K	0.50% 1/10W
Q3312	8-729-026-50	TRANSISTOR 2SA1037AK-T146-QR		R370	1-216-651-11	METAL CHIP 1K	0.50% 1/10W
Q3313	8-729-120-28	TRANSISTOR 2SC1623-L5L6		R371	1-216-025-91	RES,CHIP 100	5% 1/10W
Q3314	8-729-920-59	TRANSISTOR IMX2-T109		R372	1-216-653-11	METAL CHIP 1.2K	0.50% 1/10W
Q3315	8-729-112-65	TRANSISTOR 2SA1462-Y33		R373	1-216-025-91	RES,CHIP 100	5% 1/10W
Q3316	8-729-120-28	TRANSISTOR 2SC1623-L5L6		R374	1-216-049-91	RES,CHIP 1K	5% 1/10W
Q3317	8-729-925-42	TRANSISTOR IMT2		R375	1-216-049-91	RES,CHIP 1K	5% 1/10W
Q3318	8-729-026-50	TRANSISTOR 2SA1037AK-T146-QR		R376	1-216-025-91	RES,CHIP 100	5% 1/10W
Q3319	8-729-120-28	TRANSISTOR 2SC1623-L5L6		R377	1-216-675-91	METAL CHIP 10K	0.50% 1/10W
Q3402	1-801-806-11	TRANSISTOR DTC144EKA-T146		R378	1-218-776-11	METAL CHIP 1M	0.50% 1/10W
		<RESISTOR>		R379	1-216-675-91	METAL CHIP 10K	0.50% 1/10W
				R380	1-218-770-11	METAL CHIP 560K	0.50% 1/10W
R300	1-216-049-91	RES,CHIP 1K	5% 1/10W	R381	1-216-033-00	RES,CHIP 220	5% 1/10W
R301	1-216-025-91	RES,CHIP 100	5% 1/10W	R382	1-216-025-91	RES,CHIP 100	5% 1/10W
R302	1-216-657-11	METAL CHIP 1.8K	0.50% 1/10W	R383	1-216-053-00	RES,CHIP 1.5K	5% 1/10W
R303	1-216-663-11	METAL CHIP 3.3K	0.50% 1/10W	R384	1-216-683-11	METAL CHIP 22K	0.50% 1/10W
R305	1-216-651-11	METAL CHIP 1K	0.50% 1/10W	R385	1-218-759-11	METAL CHIP 200K	0.50% 1/10W

Ref.No.	Part No.	Description	Remark	Ref.No.	Part No.	Description	Remark				
R386	1-216-693-11	METAL CHIP	56K	0.50%	1/10W	R1312	1-216-073-00	RES,CHIP	10K	5%	1/10W
R388	1-216-089-91	RES,CHIP	47K	5%	1/10W	R1313	1-216-025-91	RES,CHIP	100	5%	1/10W
R389	1-216-025-91	RES,CHIP	100	5%	1/10W	R1314	1-216-057-00	RES,CHIP	2.2K	5%	1/10W
R390	1-216-057-00	RES,CHIP	2.2K	5%	1/10W	R1315	1-216-295-91	SHORT	0		
R391	1-216-033-00	RES,CHIP	220	5%	1/10W	R1316	1-216-675-91	METAL CHIP	10K	0.50%	1/10W
R450	1-216-025-91	RES,CHIP	100	5%	1/10W	R1317	1-216-689-11	METAL CHIP	39K	0.50%	1/10W
R451	1-216-049-91	RES,CHIP	1K	5%	1/10W	R1318	1-216-065-91	RES,CHIP	4.7K	5%	1/10W
R452	1-216-647-11	METAL CHIP	680	0.50%	1/10W	R1319	1-216-065-91	RES,CHIP	4.7K	5%	1/10W
R453	1-216-649-11	METAL CHIP	820	0.50%	1/10W	R1320	1-216-025-91	RES,CHIP	100	5%	1/10W
R454	1-216-645-11	METAL CHIP	560	0.50%	1/10W	R1321	1-216-663-11	METAL CHIP	3.3K	0.50%	1/10W
R455	1-216-647-11	METAL CHIP	680	0.50%	1/10W	R1322	1-216-657-11	METAL CHIP	1.8K	0.50%	1/10W
R456	1-216-065-91	RES,CHIP	4.7K	5%	1/10W	R1323	1-216-651-11	METAL CHIP	1K	0.50%	1/10W
R457	1-216-025-91	RES,CHIP	100	5%	1/10W	R1325	1-216-025-91	RES,CHIP	100	5%	1/10W
R458	1-216-025-91	RES,CHIP	100	5%	1/10W	R1326	1-216-653-11	METAL CHIP	1.2K	0.50%	1/10W
R459	1-216-057-00	RES,CHIP	2.2K	5%	1/10W	R1327	1-216-025-91	RES,CHIP	100	5%	1/10W
R460	1-216-671-11	METAL CHIP	6.8K	0.50%	1/10W	R1328	1-216-049-91	RES,CHIP	1K	5%	1/10W
R461	1-216-667-11	METAL CHIP	4.7K	0.50%	1/10W	R1329	1-218-776-11	METAL CHIP	1M	0.50%	1/10W
R462	1-216-671-11	METAL CHIP	6.8K	0.50%	1/10W	R1330	1-216-675-91	METAL CHIP	10K	0.50%	1/10W
R463	1-216-667-11	METAL CHIP	4.7K	0.50%	1/10W	R1331	1-216-025-91	RES,CHIP	100	5%	1/10W
R464	1-216-660-11	METAL CHIP	2.4K	0.50%	1/10W	R1332	1-216-057-00	RES,CHIP	2.2K	5%	1/10W
R465	1-216-668-11	METAL CHIP	5.1K	0.50%	1/10W	R1333	1-216-295-91	SHORT	0		
R466	1-216-663-11	METAL CHIP	3.3K	0.50%	1/10W	R1334	1-216-073-00	RES,CHIP	10K	5%	1/10W
R467	1-216-649-11	METAL CHIP	820	0.50%	1/10W	R1335	1-216-073-00	RES,CHIP	10K	5%	1/10W
R468	1-216-049-91	RES,CHIP	1K	5%	1/10W	R1340	1-216-025-91	RES,CHIP	100	5%	1/10W
R469	1-216-049-91	RES,CHIP	1K	5%	1/10W	R1341	1-216-663-11	METAL CHIP	3.3K	0.50%	1/10W
R470	1-216-651-11	METAL CHIP	1K	0.50%	1/10W	R1342	1-216-657-11	METAL CHIP	1.8K	0.50%	1/10W
R471	1-216-061-00	RES,CHIP	3.3K	5%	1/10W	R1343	1-216-651-11	METAL CHIP	1K	0.50%	1/10W
R472	1-216-025-91	RES,CHIP	100	5%	1/10W	R1345	1-216-025-91	RES,CHIP	100	5%	1/10W
R473	1-216-049-91	RES,CHIP	1K	5%	1/10W	R1346	1-216-653-11	METAL CHIP	1.2K	0.50%	1/10W
R474	1-216-647-11	METAL CHIP	680	0.50%	1/10W	R1347	1-216-025-91	RES,CHIP	100	5%	1/10W
R475	1-216-647-11	METAL CHIP	680	0.50%	1/10W	R1348	1-216-049-91	RES,CHIP	1K	5%	1/10W
R476	1-216-647-11	METAL CHIP	680	0.50%	1/10W	R1349	1-218-776-11	METAL CHIP	1M	0.50%	1/10W
R477	1-216-645-11	METAL CHIP	560	0.50%	1/10W	R1350	1-216-675-91	METAL CHIP	10K	0.50%	1/10W
R478	1-216-065-91	RES,CHIP	4.7K	5%	1/10W	R1351	1-216-025-91	RES,CHIP	100	5%	1/10W
R479	1-216-065-91	RES,CHIP	4.7K	5%	1/10W	R1352	1-216-057-00	RES,CHIP	2.2K	5%	1/10W
R480	1-216-025-91	RES,CHIP	100	5%	1/10W	R1353	1-216-295-91	SHORT	0		
R481	1-216-057-00	RES,CHIP	2.2K	5%	1/10W	R1354	1-216-685-11	METAL CHIP	27K	0.50%	1/10W
R482	1-216-025-91	RES,CHIP	100	5%	1/10W	R1355	1-216-691-11	METAL CHIP	47K	0.50%	1/10W
R483	1-216-645-11	METAL CHIP	560	0.50%	1/10W	R1357	1-216-073-00	RES,CHIP	10K	5%	1/10W
R484	1-216-021-91	RES,CHIP	68	5%	1/10W	R1358	1-216-073-00	RES,CHIP	10K	5%	1/10W
R485	1-216-671-11	METAL CHIP	6.8K	0.50%	1/10W	R1400	1-216-025-91	RES,CHIP	100	5%	1/10W
R486	1-216-661-11	METAL CHIP	2.7K	0.50%	1/10W	R1402	1-216-073-00	RES,CHIP	10K	5%	1/10W
R487	1-216-671-11	METAL CHIP	6.8K	0.50%	1/10W	R1405	1-216-025-91	RES,CHIP	100	5%	1/10W
R488	1-216-667-11	METAL CHIP	4.7K	0.50%	1/10W	R1406	1-216-025-91	RES,CHIP	100	5%	1/10W
R489	1-216-025-91	RES,CHIP	100	5%	1/10W	R1407	1-216-025-91	RES,CHIP	100	5%	1/10W
R490	1-216-049-91	RES,CHIP	1K	5%	1/10W	R1408	1-216-049-91	RES,CHIP	1K	5%	1/10W
R491	1-216-647-11	METAL CHIP	680	0.50%	1/10W	R1409	1-216-049-91	RES,CHIP	1K	5%	1/10W
R492	1-216-647-11	METAL CHIP	680	0.50%	1/10W	R1410	1-216-025-91	RES,CHIP	100	5%	1/10W
R493	1-216-647-11	METAL CHIP	680	0.50%	1/10W	R1411	1-216-085-00	RES,CHIP	33K	5%	1/10W
R494	1-216-645-11	METAL CHIP	560	0.50%	1/10W	R1412	1-216-089-91	RES,CHIP	47K	5%	1/10W
R495	1-216-065-91	RES,CHIP	4.7K	5%	1/10W	R1413	1-216-085-00	RES,CHIP	33K	5%	1/10W
R497	1-216-025-91	RES,CHIP	100	5%	1/10W	R1414	1-216-295-91	SHORT	0		
R498	1-216-057-00	RES,CHIP	2.2K	5%	1/10W	R1415	1-216-113-00	RES,CHIP	470K	5%	1/10W
R499	1-216-025-91	RES,CHIP	100	5%	1/10W	R1416	1-216-025-91	RES,CHIP	100	5%	1/10W
R1300	1-216-025-91	RES,CHIP	100	5%	1/10W	R1417	1-216-073-00	RES,CHIP	10K	5%	1/10W
R1301	1-216-663-11	METAL CHIP	3.3K	0.50%	1/10W	R1418	1-216-049-91	RES,CHIP	1K	5%	1/10W
R1302	1-216-657-11	METAL CHIP	1.8K	0.50%	1/10W	R1419	1-216-073-00	RES,CHIP	10K	5%	1/10W
R1303	1-216-651-11	METAL CHIP	1K	0.50%	1/10W	R1420	1-216-095-00	RES,CHIP	82K	5%	1/10W
R1305	1-216-025-91	RES,CHIP	100	5%	1/10W	R1421	1-216-041-00	RES,CHIP	470	5%	1/10W
R1306	1-216-653-11	METAL CHIP	1.2K	0.50%	1/10W	R1422	1-216-049-91	RES,CHIP	1K	5%	1/10W
R1307	1-216-025-91	RES,CHIP	100	5%	1/10W	R1423	1-216-049-91	RES,CHIP	1K	5%	1/10W
R1308	1-216-049-91	RES,CHIP	1K	5%	1/10W	R1424	1-216-049-91	RES,CHIP	1K	5%	1/10W
R1309	1-218-776-11	METAL CHIP	1M	0.50%	1/10W	R1425	1-216-065-91	RES,CHIP	4.7K	5%	1/10W
R1310	1-216-675-91	METAL CHIP	10K	0.50%	1/10W	R1426	1-216-025-91	RES,CHIP	100	5%	1/10W
R1311	1-216-073-00	RES,CHIP	10K	5%	1/10W	R1427	1-216-073-00	RES,CHIP	10K	5%	1/10W



Ref.No.	Part No.	Description	Remark	Ref.No.	Part No.	Description	Remark
R1428	1-216-049-91	RES,CHIP	1K 5% 1/10W	R2350	1-216-689-11	RES,CHIP	39K 5% 1/10W
R1429	1-216-073-00	RES,CHIP	10K 5% 1/10W	R2351	1-219-743-11	CARBON	100 5% 1/2W
R1430	1-216-095-00	RES,CHIP	82K 5% 1/10W	R2352	1-216-085-00	RES,CHIP	33K 5% 1/10W
R1431	1-216-041-00	RES,CHIP	470 5% 1/10W	R2353	1-216-085-00	RES,CHIP	33K 5% 1/10W
R1432	1-216-049-91	RES,CHIP	1K 5% 1/10W	R2354	1-216-653-11	METAL CHIP	1.2K 0.50% 1/10W
R1433	1-216-049-91	RES,CHIP	1K 5% 1/10W	R2355	1-216-675-91	METAL CHIP	10K 0.50% 1/10W
R1434	1-216-049-91	RES,CHIP	1K 5% 1/10W	R2356	1-216-663-11	METAL CHIP	3.3K 0.50% 1/10W
R1435	1-216-065-91	RES,CHIP	4.7K 5% 1/10W	R2357	1-216-653-11	METAL CHIP	1.2K 0.50% 1/10W
R1436	1-216-025-91	RES,CHIP	100 5% 1/10W	R2358	1-216-049-91	RES,CHIP	1K 5% 1/10W
R1437	1-216-073-00	RES,CHIP	10K 5% 1/10W	R2359	1-214-899-81	METAL	27K 1% 1/2W
R1438	1-216-049-91	RES,CHIP	1K 5% 1/10W	R2360	1-216-689-11	RES,CHIP	39K 5% 1/10W
R1439	1-216-073-00	RES,CHIP	10K 5% 1/10W	R2361	1-219-743-11	CARBON	100 5% 1/2W
R1440	1-216-095-00	RES,CHIP	82K 5% 1/10W	R2362	1-216-085-00	RES,CHIP	33K 5% 1/10W
R1441	1-216-041-00	RES,CHIP	470 5% 1/10W	R2363	1-216-085-00	RES,CHIP	33K 5% 1/10W
R1442	1-216-049-91	RES,CHIP	1K 5% 1/10W	R2364	1-216-653-11	METAL CHIP	1.2K 0.50% 1/10W
R1443	1-216-049-91	RES,CHIP	1K 5% 1/10W	R2365	1-216-675-91	METAL CHIP	10K 0.50% 1/10W
R1444	1-216-049-91	RES,CHIP	1K 5% 1/10W	R2366	1-216-663-11	METAL CHIP	3.3K 0.50% 1/10W
R1445	1-216-065-91	RES,CHIP	4.7K 5% 1/10W	R2367	1-216-653-11	METAL CHIP	1.2K 0.50% 1/10W
R1446	1-216-097-91	RES,CHIP	100K 5% 1/10W	R2368	1-216-049-91	RES,CHIP	1K 5% 1/10W
R1447	1-216-097-91	RES,CHIP	100K 5% 1/10W	R2369	1-214-899-81	METAL	27K 1% 1/2W
R1450	1-216-675-91	METAL CHIP	10K 0.50% 1/10W	R2370	1-216-689-11	RES,CHIP	39K 5% 1/10W
R1451	1-216-089-91	RES,CHIP	47K 5% 1/10W	R2371	1-219-743-11	CARBON	100 5% 1/2W
R1452	1-216-687-11	METAL CHIP	33K 0.50% 1/10W	R2372	1-216-085-00	RES,CHIP	33K 5% 1/10W
R1453	1-216-687-11	METAL CHIP	33K 0.50% 1/10W	R2373	1-216-085-00	RES,CHIP	33K 5% 1/10W
R1454	1-216-687-11	METAL CHIP	33K 0.50% 1/10W	R2374	1-216-653-11	METAL CHIP	1.2K 0.50% 1/10W
R1455	1-216-085-00	RES,CHIP	33K 5% 1/10W	R2375	1-216-073-00	RES,CHIP	10K 5% 1/10W
R1456	1-216-085-00	RES,CHIP	33K 5% 1/10W	R2376	1-216-065-91	RES,CHIP	4.7K 5% 1/10W
R1457	1-216-085-00	RES,CHIP	33K 5% 1/10W	R2380	1-216-025-91	RES,CHIP	100 5% 1/10W
R1460	1-216-113-00	RES,CHIP	470K 5% 1/10W	R2381	1-216-057-00	RES,CHIP	2.2K 5% 1/10W
R1461	1-216-085-00	RES,CHIP	33K 5% 1/10W	R2382	1-216-025-91	RES,CHIP	100 5% 1/10W
R1464	1-216-689-11	METAL CHIP	39K 0.50% 1/10W	R2383	1-216-057-00	RES,CHIP	2.2K 5% 1/10W
R1466	1-216-113-00	RES,CHIP	470K 5% 1/10W	R2384	1-216-025-91	RES,CHIP	100 5% 1/10W
R1467	1-216-083-00	RES,CHIP	27K 5% 1/10W	R2385	1-216-057-00	RES,CHIP	2.2K 5% 1/10W
R1469	1-216-653-11	METAL CHIP	1.2K 0.50% 1/10W	R2386	1-216-025-91	RES,CHIP	100 5% 1/10W
R1470	1-216-675-91	METAL CHIP	10K 0.50% 1/10W	R2387	1-216-057-00	RES,CHIP	2.2K 5% 1/10W
R1471	1-216-690-11	METAL CHIP	43K 0.50% 1/10W	R2388	1-216-073-00	RES,CHIP	10K 5% 1/10W
R1474	1-249-419-11	RES	1.5K 5% 1/4W	R2389	1-216-073-00	RES,CHIP	10K 5% 1/10W
R1475	1-249-419-11	RES	1.5K 5% 1/4W	R2390	1-216-057-00	RES,CHIP	2.2K 5% 1/10W
R1476	1-249-419-11	RES	1.5K 5% 1/4W	R2391	1-216-073-00	RES,CHIP	10K 5% 1/10W
R1480	1-216-091-00	RES,CHIP	56K 5% 1/10W	R2392	1-216-073-00	RES,CHIP	10K 5% 1/10W
R1482	1-216-073-00	RES,CHIP	10K 5% 1/10W	R2393	1-216-057-00	RES,CHIP	2.2K 5% 1/10W
R1483	1-216-089-91	RES,CHIP	47K 5% 1/10W	R3299	1-216-025-91	RES,CHIP	100 5% 1/10W
R1484	1-216-085-00	RES,CHIP	33K 5% 1/10W	R3300	1-216-025-91	RES,CHIP	100 5% 1/10W
R1485	1-216-073-00	RES,CHIP	10K 5% 1/10W	R3301	1-216-053-00	RES,CHIP	1.5K 5% 1/10W
R2294	1-216-073-00	RES,CHIP	10K 5% 1/10W	R3302	1-216-079-00	RES,CHIP	18K 5% 1/10W
R2295	1-216-065-91	RES,CHIP	4.7K 5% 1/10W	R3303	1-216-091-00	RES,CHIP	56K 5% 1/10W
R2296	1-216-073-00	RES,CHIP	10K 5% 1/10W	R3304	1-216-013-00	RES,CHIP	33 5% 1/10W
R2297	1-216-065-91	RES,CHIP	4.7K 5% 1/10W	R3305	1-216-013-00	RES,CHIP	33 5% 1/10W
R2300	1-216-025-91	RES,CHIP	100 5% 1/10W	R3306	1-216-013-00	RES,CHIP	33 5% 1/10W
R2310	1-216-065-91	RES,CHIP	4.7K 5% 1/10W	R3307	1-216-049-91	RES,CHIP	1K 5% 1/10W
R2312	1-216-295-91	SHORT	0	R3308	1-216-049-91	RES,CHIP	1K 5% 1/10W
R2313	1-216-017-91	RES,CHIP	47 5% 1/10W	R3309	1-216-049-91	RES,CHIP	1K 5% 1/10W
R2315	1-216-025-91	RES,CHIP	100 5% 1/10W	R3310	1-216-057-00	RES,CHIP	2.2K 5% 1/10W
R2325	1-216-065-91	RES,CHIP	4.7K 5% 1/10W	R3311	1-216-057-00	RES,CHIP	2.2K 5% 1/10W
R2327	1-216-295-91	SHORT	0	R3312	1-216-049-91	RES,CHIP	1K 5% 1/10W
R2328	1-216-017-91	RES,CHIP	47 5% 1/10W	R3313	1-216-063-91	RES,CHIP	3.9K 5% 1/10W
R2330	1-216-025-91	RES,CHIP	100 5% 1/10W	R3314	1-216-053-00	RES,CHIP	1.5K 5% 1/10W
R2340	1-216-065-91	RES,CHIP	4.7K 5% 1/10W	R3315	1-216-065-91	RES,CHIP	4.7K 5% 1/10W
R2342	1-216-295-91	SHORT	0	R3316	1-216-687-11	METAL CHIP	33K 0.50% 1/10W
R2343	1-216-017-91	RES,CHIP	47 5% 1/10W	R3317	1-216-663-11	METAL CHIP	3.3K 0.50% 1/10W
R2345	1-216-675-91	METAL CHIP	10K 0.50% 1/10W	R3318	1-216-651-11	METAL CHIP	1K 0.50% 1/10W
R2346	1-216-663-11	METAL CHIP	3.3K 0.50% 1/10W	R3319	1-216-083-00	RES,CHIP	27K 5% 1/10W
R2347	1-216-653-11	METAL CHIP	1.2K 0.50% 1/10W	R3320	1-216-037-00	RES,CHIP	330 5% 1/10W
R2348	1-216-049-91	RES,CHIP	1K 5% 1/10W	R3321	1-216-679-11	METAL CHIP	15K 0.50% 1/10W
R2349	1-214-899-81	METAL	27K 1% 1/2W	R3322	1-216-097-91	RES,CHIP	100K 5% 1/10W





Ref.No.	Part No.	Description	Remark	Ref.No.	Part No.	Description	Remark
C404	1-163-031-11	CERAMIC CHIP 0.01μF	50V			<RESISTOR>	
C407	1-163-038-91	CERAMIC CHIP 0.1μF	25V				
C410	1-163-038-91	CERAMIC CHIP 0.1μF	25V	R400	1-216-025-91	RES,CHIP 100 5%	1/10W
C411	1-165-319-11	CERAMIC CHIP 0.1μF	50V	R401	1-216-057-00	RES,CHIP 2.2K 5%	1/10W
C412	1-163-031-11	CERAMIC CHIP 0.01μF	50V	R402	1-216-651-11	METAL CHIP 1K 0.50%	1/10W
C502	1-163-031-11	CERAMIC CHIP 0.01μF	50V	R403	1-216-025-91	RES,CHIP 100 5%	1/10W
C503	1-163-031-11	CERAMIC CHIP 0.01μF	50V	R404	1-216-057-00	RES,CHIP 2.2K 5%	1/10W
		<CONNECTOR>		R405	1-216-651-11	METAL CHIP 1K 0.50%	1/10W
CN401	* 1-568-015-11	SOCKET, CONNECTOR 8P		R406	1-216-025-91	RES,CHIP 100 5%	1/10W
CN402	* 1-568-015-11	SOCKET, CONNECTOR 8P		R407	1-216-057-00	RES,CHIP 2.2K 5%	1/10W
		<DELAY LINE>		R408	1-216-057-00	RES,CHIP 2.2K 5%	1/10W
DL400	1-411-450-11	DELAY LINE		R409	1-216-089-91	RES,CHIP 47K 5%	1/10W
DL401	1-411-450-11	DELAY LINE		R410	1-216-025-91	RES,CHIP 100 5%	1/10W
DL402	1-234-455-21	DELAY LINE		R411	1-216-057-00	RES,CHIP 2.2K 5%	1/10W
DL403	1-234-455-21	DELAY LINE		R412	1-216-643-11	METAL CHIP 470 0.50%	1/10W
DL404	1-411-451-11	DELAY LINE		R413	1-216-025-91	RES,CHIP 100 5%	1/10W
DL405	1-234-456-21	DELAY LINE		R414	1-216-057-00	RES,CHIP 2.2K 5%	1/10W
DL501	1-402-770-11	DELAY LINE		R415	1-216-643-11	METAL CHIP 470 0.50%	1/10W
DL502	1-416-476-21	DELAY LINE		R416	1-216-025-91	RES,CHIP 100 5%	1/10W
DL503	1-402-770-11	DELAY LINE		R417	1-216-057-00	RES,CHIP 2.2K 5%	1/10W
DL504	1-416-476-21	DELAY LINE		R418	1-216-057-00	RES,CHIP 2.2K 5%	1/10W
		<IC>		R419	1-216-085-00	RES,CHIP 33K 5%	1/10W
IC410	8-759-011-65	IC MC74HC4053F		R420	1-216-025-91	RES,CHIP 100 5%	1/10W
IC450	8-752-053-21	IC CXA1211M		R421	1-216-651-11	METAL CHIP 1K 0.50%	1/10W
IC501	8-759-011-65	IC MC74HC4053F		R422	1-216-025-91	RES,CHIP 100 5%	1/10W
		<TRANSISTOR>		R423	1-216-025-91	RES,CHIP 100 5%	1/10W
Q400	8-729-120-28	TRANSISTOR 2SC1623-L5L6		R424	1-216-643-11	METAL CHIP 470 0.50%	1/10W
Q401	8-729-120-28	TRANSISTOR 2SC1623-L5L6		R425	1-216-643-11	METAL CHIP 470 0.50%	1/10W
Q402	8-729-120-28	TRANSISTOR 2SC1623-L5L6		R426	1-216-025-91	RES,CHIP 100 5%	1/10W
Q403	8-729-120-28	TRANSISTOR 2SC1623-L5L6		R427	1-216-651-11	METAL CHIP 1K 0.50%	1/10W
Q404	8-729-026-50	TRANSISTOR 2SA1037AK-T146-QR		R428	1-216-057-00	RES,CHIP 2.2K 5%	1/10W
Q405	8-729-112-65	TRANSISTOR 2SA1462-T1Y33		R429	1-216-057-00	RES,CHIP 2.2K 5%	1/10W
Q406	8-729-112-65	TRANSISTOR 2SA1462-T1Y33		R430	1-216-025-91	RES,CHIP 100 5%	1/10W
Q407	8-729-112-65	TRANSISTOR 2SA1462-T1Y33		R431	1-216-025-91	RES,CHIP 100 5%	1/10W
Q408	8-729-107-31	TRANSISTOR 2SC3545-T43		R432	1-216-061-00	RES,CHIP 3.3K 5%	1/10W
Q409	8-729-107-31	TRANSISTOR 2SC3545-T43		R433	1-216-075-00	RES,CHIP 12K 5%	1/10W
Q410	1-801-806-11	TRANSISTOR DTC144EKA-T146		R434	1-216-065-91	RES,CHIP 4.7K 5%	1/10W
Q411	8-729-120-28	TRANSISTOR 2SC1623-L5L6		R435	1-216-051-00	RES,CHIP 1.2K 5%	1/10W
Q412	8-729-107-31	TRANSISTOR 2SC3545-T43		R436	1-216-065-91	RES,CHIP 4.7K 5%	1/10W
Q413	8-729-120-28	TRANSISTOR 2SC1623-L5L6		R437	1-216-057-00	RES,CHIP 2.2K 5%	1/10W
Q414	8-729-107-31	TRANSISTOR 2SC3545-T43		R438	1-216-073-00	RES,CHIP 10K 5%	1/10W
Q501	8-729-026-50	TRANSISTOR 2SA1037AK-T146-QR		R439	1-216-057-00	RES,CHIP 2.2K 5%	1/10W
Q502	8-729-107-31	TRANSISTOR 2SC3545-T43		R440	1-216-049-91	RES,CHIP 1K 5%	1/10W
Q503	8-729-112-65	TRANSISTOR 2SA1462-T1Y33		R441	1-216-295-91	SHORT 0	
Q504	8-729-026-50	TRANSISTOR 2SA1037AK-T146-QR		R442	1-216-025-91	RES,CHIP 100 5%	1/10W
Q505	8-729-107-31	TRANSISTOR 2SC3545-T43		R443	1-216-025-91	RES,CHIP 100 5%	1/10W
Q506	8-729-112-65	TRANSISTOR 2SA1462-T1Y33		R444	1-216-025-91	RES,CHIP 100 5%	1/10W
Q511	8-729-120-28	TRANSISTOR 2SC1623-L5L6		R501	1-216-025-91	RES,CHIP 100 5%	1/10W
Q512	8-729-107-31	TRANSISTOR 2SC3545-T43		R502	1-216-057-00	RES,CHIP 2.2K 5%	1/10W
Q513	8-729-112-65	TRANSISTOR 2SA1462-T1Y33		R503	1-216-651-11	METAL CHIP 1K 0.50%	1/10W
Q514	8-729-107-31	TRANSISTOR 2SC3545-T43		R504	1-216-651-11	METAL CHIP 1K 0.50%	1/10W
Q515	8-729-120-28	TRANSISTOR 2SC1623-L5L6		R505	1-216-025-91	RES,CHIP 100 5%	1/10W
Q516	8-729-107-31	TRANSISTOR 2SC3545-T43		R506	1-216-025-91	RES,CHIP 100 5%	1/10W
Q517	8-729-112-65	TRANSISTOR 2SA1462-T1Y33		R507	1-216-057-00	RES,CHIP 2.2K 5%	1/10W
Q518	8-729-107-31	TRANSISTOR 2SC3545-T43		R508	1-216-025-91	RES,CHIP 100 5%	1/10W
				R509	1-216-037-00	RES,CHIP 330 5%	1/10W
				R510	1-216-631-11	METAL CHIP 150 0.50%	1/10W
				R511	1-216-631-11	METAL CHIP 150 0.50%	1/10W
				R512	1-216-025-91	RES,CHIP 100 5%	1/10W
				R513	1-216-025-91	RES,CHIP 100 5%	1/10W
				R514	1-216-057-00	RES,CHIP 2.2K 5%	1/10W
				R515	1-216-651-11	METAL CHIP 1K 0.50%	1/10W
				R516	1-216-651-11	METAL CHIP 1K 0.50%	1/10W
				R517	1-216-025-91	RES,CHIP 100 5%	1/10W
				R518	1-216-025-91	RES,CHIP 100 5%	1/10W
				R519	1-216-057-00	RES,CHIP 2.2K 5%	1/10W
				R520	1-216-025-91	RES,CHIP 100 5%	1/10W

Ref.No.	Part No.	Description	Remark	Ref.No.	Part No.	Description	Remark
R521	1-216-037-00	RES,CHIP 330	5% 1/10W		<IC>		
R522	1-216-631-11	METAL CHIP 150	0.50% 1/10W				
R523	1-216-631-11	METAL CHIP 150	0.50% 1/10W	IC3901	8-759-239-34	IC TC74HC4538AF	
R524	1-216-025-91	RES,CHIP 100	5% 1/10W	IC3902	8-759-523-02	IC TC74HC4053AFT(EL)	
R531	1-216-057-00	RES,CHIP 2.2K	5% 1/10W	IC3904	8-759-239-34	IC TC74HC4538AF	
				IC3905	8-759-100-96	IC UPC4558G2	
R532	1-216-057-00	RES,CHIP 2.2K	5% 1/10W	IC3906	8-759-234-20	IC TC7S08F	
R533	1-216-061-00	RES,CHIP 3.3K	5% 1/10W				
R534	1-216-069-00	RES,CHIP 6.8K	5% 1/10W	IC3907	8-759-035-90	IC SC7S02F	
R535	1-216-057-00	RES,CHIP 2.2K	5% 1/10W	IC3908	8-759-082-61	IC TC4W53FU	
R536	1-216-057-00	RES,CHIP 2.2K	5% 1/10W				
R537	1-216-025-91	RES,CHIP 100	5% 1/10W		<TRANSISTOR>		
R538	1-216-051-00	RES,CHIP 1.2K	5% 1/10W	Q3901	8-729-027-38	TRANSISTOR DTA144EKA-T146	
R541	1-216-057-00	RES,CHIP 2.2K	5% 1/10W	Q3902	8-729-027-38	TRANSISTOR DTA144EKA-T146	
R542	1-216-057-00	RES,CHIP 2.2K	5% 1/10W	Q3903	8-729-026-50	TRANSISTOR 2SA1037AK-T146-QR	
R543	1-216-061-00	RES,CHIP 3.3K	5% 1/10W	Q3905	8-729-026-50	TRANSISTOR 2SA1037AK-T146-QR	
				Q3906	8-729-027-38	TRANSISTOR DTA144EKA-T146	
R544	1-216-069-00	RES,CHIP 6.8K	5% 1/10W				
R545	1-216-057-00	RES,CHIP 2.2K	5% 1/10W	Q3907	8-729-120-28	TRANSISTOR 2SC1623-L5L6	
R546	1-216-057-00	RES,CHIP 2.2K	5% 1/10W	Q3908	8-729-026-50	TRANSISTOR 2SA1037AK-T146-QR	
R547	1-216-025-91	RES,CHIP 100	5% 1/10W	Q3909	8-729-026-50	TRANSISTOR 2SA1037AK-T146-QR	
R548	1-216-051-00	RES,CHIP 1.2K	5% 1/10W	Q3910	8-729-026-50	TRANSISTOR 2SA1037AK-T146-QR	
				Q3911	1-801-806-11	TRANSISTOR DTC144EKA-T146	
				Q3912	8-729-202-38	TRANSISTOR 2SC3326N-A	
				Q3913	8-729-202-38	TRANSISTOR 2SC3326N-A	
				Q3914	8-729-120-28	TRANSISTOR 2SC1623-L5L6	
				Q3915	8-729-026-50	TRANSISTOR 2SA1037AK-T146-QR	
				Q3916	8-729-120-28	TRANSISTOR 2SC1623-L5L6	
*****							
	* A-1131-464-A	B2 MOUNT	*****				
		<CAPACITOR>					
C3901	1-163-031-11	CERAMIC CHIP 0.01μF	50V				
C3902	1-164-161-11	CERAMIC CHIP 0.0022μF	10% 50V				
C3903	1-163-133-00	CERAMIC CHIP 470PF	5% 50V	R3901	1-216-025-91	RES,CHIP 100	5% 1/10W
C3904	1-163-017-00	CERAMIC CHIP 0.0047μF	10% 50V	R3902	1-216-025-91	RES,CHIP 100	5% 1/10W
C3905	1-164-161-11	CERAMIC CHIP 0.0022μF	10% 100V	R3903	1-216-659-11	METAL CHIP 2.2K	0.50% 1/10W
				R3904	1-216-025-91	RES,CHIP 100	5% 1/10W
C3906	1-163-251-11	CERAMIC CHIP 100PF	5% 50V	R3905	1-218-754-11	METAL CHIP 120K	0.50% 1/10W
C3907	1-163-133-00	CERAMIC CHIP 470PF	5% 50V				
C3908	1-164-346-11	CERAMIC CHIP 1μF	16V	R3906	1-216-659-11	METAL CHIP 2.2K	0.50% 1/10W
C3909	1-163-259-91	CERAMIC CHIP 220PF	5% 50V	R3907	1-218-753-11	METAL CHIP 110K	0.50% 1/10W
C3910	1-163-031-11	CERAMIC CHIP 0.01μF	50V	R3908	1-216-059-00	RES,CHIP 2.7K	5% 1/10W
				R3909	1-216-659-11	METAL CHIP 2.2K	0.50% 1/10W
C3912	1-163-127-00	CERAMIC CHIP 270PF	5% 50V	R3910	1-216-753-11	METAL CHIP 110K	0.50% 1/10W
C3913	1-163-031-11	CERAMIC CHIP 0.01μF	50V				
C3914	1-163-031-11	CERAMIC CHIP 0.01μF	50V	R3912	1-216-057-00	RES,CHIP 2.2K	5% 1/10W
C3915	1-163-259-91	CERAMIC CHIP 220PF	5% 50V	R3913	1-216-655-11	METAL CHIP 1.5K	0.50% 1/10W
C3916	1-163-031-11	CERAMIC CHIP 0.01μF	50V	R3914	1-216-025-91	RES,CHIP 100	5% 1/10W
				R3915	1-216-674-11	METAL CHIP 9.1K	0.50% 1/10W
C3917	1-163-031-11	CERAMIC CHIP 0.01μF	50V	R3916	1-216-025-91	RES,CHIP 100	5% 1/10W
C3918	1-163-031-11	CERAMIC CHIP 0.01μF	50V				
C3919	1-163-031-11	CERAMIC CHIP 0.01μF	50V	R3917	1-216-097-91	RES,CHIP 100K	5% 1/10W
C3920	1-163-031-11	CERAMIC CHIP 0.01μF	50V	R3918	1-216-049-91	RES,CHIP 1K	5% 1/10W
C3921	1-164-489-11	CERAMIC CHIP 0.22μF	10% 16V	R3919	1-216-065-91	RES,CHIP 4.7K	5% 1/10W
				R3920	1-216-049-91	RES,CHIP 1K	5% 1/10W
C3922	1-164-489-11	CERAMIC CHIP 0.22μF	10% 16V	R3922	1-216-689-11	METAL CHIP 39K	0.50% 1/10W
C3923	1-163-031-11	CERAMIC CHIP 0.01μF	50V				
C3924	1-163-031-11	CERAMIC CHIP 0.01μF	50V	R3923	1-216-025-91	RES,CHIP 100	5% 1/10W
				R3924	1-216-681-11	METAL CHIP 18K	0.50% 1/10W
				R3925	1-216-697-91	METAL CHIP 82K	0.50% 1/10W
				R3926	1-216-049-91	RES,CHIP 1K	5% 1/10W
				R3927	1-216-699-91	METAL CHIP 100K	0.50% 1/10W
		<CONNECTOR>					
CN3901	* 1-573-896-11	SOCKET, CONNECTOR 12P		R3928	1-216-025-91	RES,CHIP 100	5% 1/10W
CN3902	* 1-573-896-11	SOCKET, CONNECTOR 12P		R3929	1-216-681-11	METAL CHIP 18K	0.50% 1/10W
				R3930	1-216-675-91	METAL CHIP 10K	0.50% 1/10W
				R3931	1-216-049-91	RES,CHIP 1K	5% 1/10W
				R3932	1-216-653-11	METAL CHIP 1.2K	0.50% 1/10W
		<DIODE>					
D3901	8-719-016-74	DIODE 1SS352		R3933	1-216-651-11	METAL CHIP 1K	0.50% 1/10W
D3902	8-719-016-74	DIODE 1SS352		R3934	1-216-025-91	RES,CHIP 100	5% 1/10W
D3903	8-719-016-74	DIODE 1SS352		R3935	1-216-049-91	RES,CHIP 1K	5% 1/10W
D3904	8-719-016-74	DIODE 1SS352		R3936	1-216-097-91	RES,CHIP 100K	5% 1/10W
				R3937	1-216-025-91	RES,CHIP 100	5% 1/10W

Ref.No.	Part No.	Description	Remark	Ref.No.	Part No.	Description	Remark
R3938	1-216-073-00	RES,CHIP 10K	5% 1/10W	C501	1-128-526-11	ELECT 100μF	20% 16V
R3939	1-216-097-91	RES,CHIP 100K	5% 1/10W	C502	1-163-038-91	CERAMIC CHIP 0.1μF	25V
R3940	1-216-073-00	RES,CHIP 10K	5% 1/10W	C503	1-163-038-91	CERAMIC CHIP 0.1μF	25V
R3941	1-216-049-91	RES,CHIP 1K	5% 1/10W	<CONNECTOR>			
R3942	1-216-081-00	RES,CHIP 22K	5% 1/10W	CN001	* 1-774-523-11	PIN, CONNECTOR (PC BOARD) 64P	
R3943	1-216-055-00	RES,CHIP 1.8K	5% 1/10W	<DIODE>			
R3944	1-216-049-91	RES,CHIP 1K	5% 1/10W	D101	8-719-073-01	DIODE MA111-(K8).SO	
R3945	1-216-079-00	RES,CHIP 18K	5% 1/10W	D102	8-719-073-01	DIODE MA111-(K8).SO	
R3946	1-216-059-00	RES,CHIP 2.7K	5% 1/10W	D201	8-719-073-01	DIODE MA111-(K8).SO	
R3947	1-216-089-91	RES,CHIP 47K	5% 1/10W	D202	8-719-073-01	DIODE MA111-(K8).SO	
R3948	1-216-295-91	SHORT 0		D301	8-719-073-01	DIODE MA111-(K8).SO	
*****							
* A-1136-013-A BX COMPL							
*****							
<CAPACITOR>							
C010	1-128-526-11	ELECT 100μF	20% 16V	<FILTER>			
C011	1-163-038-91	CERAMIC CHIP 0.1μF	25V	FL501	1-239-183-11	FILTER, EMI	
C012	1-128-526-11	ELECT 100μF	20% 16V	FL502	1-239-480-11	FILTER, EMI	
C013	1-163-038-91	CERAMIC CHIP 0.1μF	25V	FL503	1-239-480-11	FILTER, EMI	
C014	1-128-526-11	ELECT 100μF	20% 16V	<IC>			
C015	1-163-038-91	CERAMIC CHIP 0.1μF	25V	IC010	8-759-460-74	IC BA05FP-E2	
C016	1-163-038-91	CERAMIC CHIP 0.1μF	25V	IC050	8-759-539-89	IC LM2990SX-5.0	
C017	1-163-038-91	CERAMIC CHIP 0.1μF	25V	IC501	8-759-594-41	IC MB89613R-651	
C018	1-163-038-91	CERAMIC CHIP 0.1μF	25V	IC502	8-759-186-44	IC TC74VHC125F	
C019	1-163-038-91	CERAMIC CHIP 0.1μF	25V	IC503	8-759-156-54	IC X25040SI	
C020	1-163-038-91	CERAMIC CHIP 0.1μF	25V	<TRANSISTOR>			
C021	1-163-038-91	CERAMIC CHIP 0.1μF	25V	Q101	8-729-112-65	TRANSISTOR 2SA1462-Y33	
C022	1-163-038-91	CERAMIC CHIP 0.1μF	25V	Q102	8-729-027-38	TRANSISTOR DTA144EKA-T146	
C050	1-128-526-11	ELECT 100μF	20% 16V	Q103	8-729-107-31	TRANSISTOR 2SC3545-T43	
C051	1-163-038-91	CERAMIC CHIP 0.1μF	25V	Q201	8-729-112-65	TRANSISTOR 2SA1462-Y33	
C052	1-128-526-11	ELECT 100μF	20% 16V	Q202	8-729-027-38	TRANSISTOR DTA144EKA-T146	
C053	1-163-038-91	CERAMIC CHIP 0.1μF	25V	Q203	8-729-107-31	TRANSISTOR 2SC3545-T43	
C054	1-128-526-11	ELECT 100μF	20% 16V	Q301	8-729-112-65	TRANSISTOR 2SA1462-Y33	
C055	1-163-038-91	CERAMIC CHIP 0.1μF	25V	Q302	8-729-027-38	TRANSISTOR DTA144EKA-T146	
C056	1-163-038-91	CERAMIC CHIP 0.1μF	25V	Q303	8-729-107-31	TRANSISTOR 2SC3545-T43	
C057	1-163-038-91	CERAMIC CHIP 0.1μF	25V	Q401	8-729-120-28	TRANSISTOR 2SC1623-L5L6	
C058	1-163-038-91	CERAMIC CHIP 0.1μF	25V	Q402	1-801-806-11	TRANSISTOR DTC144EKA-T146	
C059	1-163-038-91	CERAMIC CHIP 0.1μF	25V	Q403	8-729-026-49	TRANSISTOR 2SA1037AK-T146-R	
C060	1-163-038-91	CERAMIC CHIP 0.1μF	25V	Q404	8-729-027-38	TRANSISTOR DTA144EKA-T146	
C061	1-163-038-91	CERAMIC CHIP 0.1μF	25V	Q501	1-801-806-11	TRANSISTOR DTC144EKA-T146	
C062	1-163-038-91	CERAMIC CHIP 0.1μF	25V	<RESISTOR>			
C101	1-163-227-11	CERAMIC CHIP 10PF	0.5PF 50V	R101	1-214-837-11	METAL 75	1% 1/2W
C102	1-163-235-11	CERAMIC CHIP 22PF	5% 50V	R102	1-216-089-91	RES,CHIP 47K	5% 1/10W
C103	1-107-701-11	ELECT 47μF	20% 16V	R103	1-216-025-91	RES,CHIP 100	5% 1/10W
C104	1-107-725-11	CERAMIC CHIP 0.1μF	10% 16V	R104	1-216-057-00	RES,CHIP 2.2K	5% 1/10W
C106	1-163-021-91	CERAMIC CHIP 0.01μF	10% 50V	R105	1-216-097-91	RES,CHIP 100K	5% 1/10W
C201	1-163-227-11	CERAMIC CHIP 10PF	0.5PF 50V	R106	1-216-009-91	RES,CHIP 22	5% 1/10W
C202	1-163-235-11	CERAMIC CHIP 22PF	5% 50V	R107	1-216-025-91	RES,CHIP 100	5% 1/10W
C203	1-107-701-11	ELECT 47μF	20% 16V	R108	1-216-097-91	RES,CHIP 100K	5% 1/10W
C204	1-107-725-11	CERAMIC CHIP 0.1μF	10% 16V	R109	1-216-013-00	RES,CHIP 33	5% 1/10W
C206	1-163-021-91	CERAMIC CHIP 0.01μF	10% 50V	R201	1-214-837-11	METAL 75	1% 1/2W
C301	1-163-227-11	CERAMIC CHIP 10PF	0.5PF 50V	R202	1-216-089-91	RES,CHIP 47K	5% 1/10W
C302	1-163-235-11	CERAMIC CHIP 22PF	5% 50V	R203	1-216-025-91	RES,CHIP 100	5% 1/10W
C303	1-107-701-11	ELECT 47μF	20% 16V	R204	1-216-057-00	RES,CHIP 2.2K	5% 1/10W
C304	1-107-725-11	CERAMIC CHIP 0.1μF	10% 16V	R205	1-216-097-91	RES,CHIP 100K	5% 1/10W
C306	1-163-021-91	CERAMIC CHIP 0.01μF	10% 50V	R206	1-216-009-91	RES,CHIP 22	5% 1/10W
C401	1-163-091-00	CERAMIC CHIP 8PF	0.25PF 50V				
C402	1-163-235-11	CERAMIC CHIP 22PF	5% 50V				
C403	1-107-701-11	ELECT 47μF	20% 16V				
C404	1-107-725-11	CERAMIC CHIP 0.1μF	10% 16V				

Ref.No.	Part No.	Description	Remark	Ref.No.	Part No.	Description	Remark
R207	1-216-025-91	RES,CHIP	100 5% 1/10W			<CAPACITOR>	
R208	1-216-097-91	RES,CHIP	100K 5% 1/10W				
R209	1-216-013-00	RES,CHIP	33 5% 1/10W	C701	1-162-114-00	CERAMIC 0.0047μF 2KV	
R301	1-214-837-11	METAL	75 1% 1/2W	C702	1-104-665-11	ELECT 100μF 20% 25V	
R302	1-216-089-91	RES,CHIP	47K 5% 1/10W	C703	1-162-114-00	CERAMIC 0.0047μF 2KV	
				C710	1-161-830-00	CERAMIC 0.0047μF 500V	
R303	1-216-025-91	RES,CHIP	100 5% 1/10W			<CONNECTOR>	
R304	1-216-057-00	RES,CHIP	2.2K 5% 1/10W				
R305	1-216-097-91	RES,CHIP	100K 5% 1/10W	CN701	* 1-564-509-11	PLUG, CONNECTOR 6P	
R306	1-216-009-91	RES,CHIP	22 5% 1/10W	CN702	* 1-508-784-00	PIN, CONNECTOR (5MM PITCH) 1P	
R307	1-216-025-91	RES,CHIP	100 5% 1/10W	CN703	* 1-564-509-11	PLUG, CONNECTOR 6P	
R308	1-216-097-91	RES,CHIP	100K 5% 1/10W			<COMPOSITION CIRCUIT BLOCK>	
R309	1-216-013-00	RES,CHIP	33 5% 1/10W	CP701	1-453-105-11	CR PACK, HIGH-VOLTAGE	
R401	1-214-837-11	METAL	75 1% 1/2W			<DIODE>	
R402	1-216-089-91	RES,CHIP	47K 5% 1/10W				
R403	1-216-049-91	RES,CHIP	1K 5% 1/10W	D701	8-719-911-19	DIODE 1SS119-25	
R404	1-216-097-91	RES,CHIP	100K 5% 1/10W			<JACK>	
R405	1-216-057-00	RES,CHIP	2.2K 5% 1/10W	J701	1-251-244-11	SOCKET, CRT	
R406	1-216-009-91	RES,CHIP	22 5% 1/10W			<COIL>	
R407	1-216-025-91	RES,CHIP	100 5% 1/10W	L701	1-408-608-31	INDUCTOR 27μH	
R408	1-216-097-91	RES,CHIP	100K 5% 1/10W	L702	1-408-601-31	INDUCTOR 6.8μH	
R409	1-216-013-00	RES,CHIP	33 5% 1/10W	L703	1-408-601-31	INDUCTOR 6.8μH	
R410	1-216-097-91	RES,CHIP	100K 5% 1/10W	L704	1-408-601-31	INDUCTOR 6.8μH	
R501	1-216-097-91	RES,CHIP	100K 5% 1/10W			<TRANSISTOR>	
R502	1-216-025-91	RES,CHIP	100 5% 1/10W	Q701	8-729-020-07	TRANSISTOR 2SC4686A(LBSONY)	
R503	1-216-025-91	RES,CHIP	100 5% 1/10W			<RESISTOR>	
R504	1-216-097-91	RES,CHIP	100K 5% 1/10W	R701	1-219-747-91	CARBON 2.2K 5% 1/2W	
R505	1-216-025-91	RES,CHIP	100 5% 1/10W	R702	1-219-747-91	CARBON 2.2K 5% 1/2W	
R506	1-216-097-91	RES,CHIP	100K 5% 1/10W	R703	1-219-747-91	CARBON 2.2K 5% 1/2W	
R507	1-216-025-91	RES,CHIP	100 5% 1/10W	R704	1-219-752-11	CARBON 100K 5% 1/2W	
R508	1-216-097-91	RES,CHIP	100K 5% 1/10W	R706	1-219-753-11	CARBON 220K 5% 1/2W	
R509	1-216-097-91	RES,CHIP	100K 5% 1/10W	R707	1-219-752-11	CARBON 100K 5% 1/2W	
R510	1-216-097-91	RES,CHIP	100K 5% 1/10W	R708	1-249-429-11	CARBON 10K 5% 1/4W	
R511	1-216-097-91	RES,CHIP	100K 5% 1/10W	R709	1-249-417-11	CARBON 1K 5% 1/4W	
R512	1-216-097-91	RES,CHIP	100K 5% 1/10W			<VARIABLE RESISTOR>	
R513	1-216-097-91	RES,CHIP	100K 5% 1/10W	RV701	△1-230-164-00	RES, ADJ, METAL GLAZE 55M	
R514	1-216-097-91	RES,CHIP	100K 5% 1/10W				
R515	1-216-097-91	RES,CHIP	100K 5% 1/10W				
R516	1-216-065-91	RES,CHIP	4.7K 5% 1/10W				
R517	1-216-097-91	RES,CHIP	100K 5% 1/10W				
R518	1-216-097-91	RES,CHIP	100K 5% 1/10W				
		<TERMINAL BOARD>					
TB001	1-694-601-11	TERMINAL BOARD ASSY, I/O					
		<TEST PIN>					
TP001	* 1-537-864-11	PIN, POST					
TP010	* 1-537-864-11	PIN, POST					
		<CRYSTAL>					
X501	1-578-689-21	VIBRATOR (8 MHz)					
*****				*****			
	* A-1331-957-A	C MOUNT			* A-1335-118-A	D COMPL	
		*****				*****	
	* 4-376-132-11	COVER(REAR LID), CV VOL			4-048-257-01	HOLDER (C), TR	
	* 4-376-133-11	COVER(MAIN), CV VOL			4-381-907-01	INSULATOR (A)	
					4-382-854-11	SCREW(M3X10), P, SW (+)	
						<CAPACITOR>	
				C1600	1-107-914-11	ELECT 1000μF 20% 25V	
				C1601	1-128-526-11	ELECT 100μF 20% 25V	
				C1602	1-163-031-11	CERAMIC CHIP 0.01μF 50V	
				C1603	1-126-096-11	ELECT 10μF 20% 35V	
				C1604	1-124-589-11	ELECT 47μF 20% 16V	



Ref.No.	Part No.	Description	Remark	Ref.No.	Part No.	Description	Remark
C1605	1-124-589-11	ELECT 47μF	20% 16V	C2551	1-163-809-11	CERAMIC CHIP 0.047μF	10% 25V
C1606	1-126-096-11	ELECT 10μF	20% 35V	C2552	1-164-346-11	CERAMIC CHIP 1μF	16V
C1607	1-163-031-11	CERAMIC CHIP 0.01μF	50V	C2553	1-164-004-11	CERAMIC CHIP 0.1μF	10% 25V
C1608	1-163-037-11	CERAMIC CHIP 0.022μF	10% 50V	C2554	1-126-176-11	ELECT 220μF	20% 10V
C1609	1-164-505-11	CERAMIC CHIP 2.2μF	16V	C2556	1-162-558-11	CERAMIC 100PF	10% 2KV
C1610	1-163-251-11	CERAMIC CHIP 100PF	5% 50V	C2557	1-130-061-91	FILM 0.0015μF	5% 630V
C1611	1-163-131-00	CERAMIC CHIP 390PF	5% 50V	C2558	1-162-558-11	CERAMIC 100PF	10% 2KV
C1612	1-163-031-11	CERAMIC CHIP 0.01μF	50V	C2559	1-163-031-11	CERAMIC CHIP 0.01μF	50V
C1615	1-128-077-11	ELECT 22μF	20% 25V	C2560	1-163-021-91	CERAMIC CHIP 0.01μF	10% 50V
C1616	1-165-319-11	CERAMIC CHIP 0.1μF	50V	C2561	1-107-746-11	ELECT 10μF	20% 200V
C1617	1-126-096-11	ELECT 10μF	20% 35V	C2562	1-115-522-11	FILM 1μF	5% 250V
C1618	1-107-914-11	ELECT 1000μF	20% 25V	C2563	1-117-673-11	FILM 1.5μF	5% 250V
C1619	1-163-031-11	CERAMIC CHIP 0.01μF	50V	C2564	1-117-674-11	FILM 1.8μF	5% 250V
C1620	1-128-339-11	ELECT 2200μF	20% 6.3V	C2565	1-163-021-91	CERAMIC CHIP 0.01μF	10% 50V
C1621	1-163-031-11	CERAMIC CHIP 0.01μF	50V	C2566	1-163-021-91	CERAMIC CHIP 0.01μF	10% 50V
C1622	1-104-653-11	ELECT 220μF	20% 6.3V	C2567	1-107-909-11	ELECT 47μF	20% 16V
C1623	1-163-031-11	CERAMIC CHIP 0.01μF	50V	C2568	1-163-031-11	CERAMIC CHIP 0.01μF	50V
C1625	1-164-004-11	CERAMIC CHIP 0.1μF	10% 25V	C2569	1-128-954-11	ELECT 1000μF	20% 25V
C2501	1-107-889-11	ELECT 220μF	20% 25V	C2570	1-163-031-11	CERAMIC CHIP 0.01μF	50V
C2502	1-163-021-91	CERAMIC CHIP 0.01μF	10% 50V	C2571	1-107-909-11	ELECT 47μF	20% 16V
C2503	1-163-031-11	CERAMIC CHIP 0.01μF	50V	C2572	1-163-021-91	CERAMIC CHIP 0.01μF	10% 50V
C2504	1-163-133-00	CERAMIC CHIP 470PF	5% 50V	C2575	1-163-031-11	CERAMIC CHIP 0.01μF	50V
C2505	1-125-838-91	CERAMIC CHIP 2.2μF	10% 6.3V	C2576	1-107-902-11	ELECT 1μF	20% 50V
C2506	1-163-021-91	CERAMIC CHIP 0.01μF	10% 50V	C2577	1-125-898-91	CERAMIC CHIP 0.22μF	10% 50V
C2507	1-163-031-11	CERAMIC CHIP 0.01μF	50V	C2578	1-107-905-11	ELECT 4.7μF	20% 50V
C2508	1-163-037-11	CERAMIC CHIP 0.022μF	10% 50V	C2579	1-128-526-11	ELECT 100μF	20% 16V
C2509	1-107-909-11	ELECT 47μF	20% 16V	C2580	1-125-838-91	CERAMIC CHIP 2.2μF	6.3V
C2510	1-163-021-91	CERAMIC CHIP 0.01μF	10% 50V	C2582	1-107-909-11	ELECT 47μF	20% 16V
C2511	1-163-017-00	CERAMIC CHIP 0.0047μF	10% 50V	C2583	1-163-021-91	CERAMIC CHIP 0.01μF	10% 50V
C2512	1-163-017-00	CERAMIC CHIP 0.0047μF	10% 50V	C2584	1-163-021-91	CERAMIC CHIP 0.01μF	10% 50V
C2513	1-163-275-11	CERAMIC CHIP 0.001μF	5% 50V	C2586	1-164-489-11	CERAMIC CHIP 0.22μF	10% 16V
C2514	1-163-809-11	CERAMIC CHIP 0.047μF	10% 25V	C2587	1-163-021-91	CERAMIC CHIP 0.01μF	10% 50V
C2515	1-107-906-11	ELECT 10μF	20% 50V	C2588	1-107-909-11	ELECT 47μF	20% 16V
C2516	1-164-222-11	CERAMIC CHIP 0.22μF	25V	C2589	1-107-823-11	CERAMIC CHIP 0.47μF	10% 16V
C2517	1-164-346-11	CERAMIC CHIP 1μF	16V	C2592	1-163-133-00	CERAMIC CHIP 470PF	5% 50V
C2518	1-107-910-11	ELECT 100μF	20% 50V	C2593	1-124-589-11	ELECT 47μF	20% 16V
C2519	1-107-823-11	CERAMIC CHIP 0.47μF	10% 16V	C2594	1-163-021-91	CERAMIC CHIP 0.01μF	10% 50V
C2520	1-163-139-00	CERAMIC CHIP 820PF	5% 50V	C2595	1-104-555-11	FILM CHIP 0.022μF	5% 16V
C2522	1-127-820-91	CERAMIC 4.7μF	0 16V	C2601	1-163-031-11	CERAMIC CHIP 0.01μF	50V
C2523	1-125-827-91	CERAMIC CHIP 1μF	10% 25V	C2602	1-163-037-11	CERAMIC CHIP 0.022μF	10% 50V
C2524	1-163-009-11	CERAMIC CHIP 0.001μF	10% 50V	C2603	1-164-505-11	CERAMIC CHIP 2.2μF	16V
C2525	1-163-021-91	CERAMIC CHIP 0.01μF	10% 50V	C2604	1-163-251-11	CERAMIC CHIP 100PF	5% 50V
C2526	1-164-344-11	CERAMIC CHIP 0.068μF	10% 25V	C2605	1-163-131-00	CERAMIC CHIP 390PF	5% 50V
C2527	1-127-820-91	CERAMIC 4.7μF	0 16V	C2606	1-163-031-11	CERAMIC CHIP 0.01μF	50V
C2528	1-126-163-11	ELECT 4.7μF	20% 25V	C2607	1-163-037-11	CERAMIC CHIP 0.022μF	10% 50V
C2529	1-125-838-91	CERAMIC CHIP 2.2μF	6.3V	C2608	1-163-251-11	CERAMIC CHIP 100PF	5% 50V
C2530	1-163-021-91	CERAMIC CHIP 0.01μF	10% 50V	C2609	1-128-077-11	ELECT 22μF	20% 25V
C2531	1-163-021-91	CERAMIC CHIP 0.01μF	10% 50V	C2610	1-165-319-11	CERAMIC CHIP 0.1μF	50V
C2532	1-107-884-11	ELECT 1000μF	20% 16V	C2611	1-126-096-11	ELECT 10μF	20% 35V
C2533	1-107-884-11	ELECT 1000μF	20% 16V	C2612	1-107-914-11	ELECT 1000μF	20% 25V
C2534	1-107-910-11	ELECT 100μF	20% 50V	C2613	1-163-031-11	CERAMIC CHIP 0.01μF	50V
C2535	1-106-228-00	MYLAR 0.22μF	10% 100V	C2614	1-128-339-11	ELECT 2200μF	20% 10V
C2536	1-164-161-11	CERAMIC CHIP 0.0022μF	10% 50V	C2616	1-163-031-11	CERAMIC CHIP 0.01μF	50V
C2537	1-126-964-11	ELECT 10μF	20% 50V	C2617	1-107-889-11	ELECT 220μF	20% 10V
C2538	1-164-004-11	CERAMIC CHIP 0.1μF	10% 25V	C2618	1-163-031-11	CERAMIC CHIP 0.01μF	50V
C2539	1-163-005-11	CERAMIC CHIP 470PF	10% 50V	C2619	1-104-653-11	ELECT 220μF	20% 6.3V
C2540	1-162-318-11	CERAMIC 0.001μF	10% 500V	C2620	1-107-914-11	ELECT 1000μF	20% 25V
C2541	1-107-364-11	MYLAR 0.01μF	10% 200V	C2621	1-163-031-11	CERAMIC CHIP 0.01μF	50V
C2542	1-124-628-11	ELECT 220μF	20% 100V	C2622	1-128-339-11	ELECT 2200μF	20% 10V
C2543	1-107-906-11	ELECT 10μF	20% 50V	C2623	1-163-031-11	CERAMIC CHIP 0.01μF	50V
C2544	1-163-021-91	CERAMIC CHIP 0.01μF	10% 50V	C2624	1-107-889-11	ELECT 220μF	20% 10V
C2545	1-162-129-91	CERAMIC 150PF	10% 2KV	C2625	1-163-031-11	CERAMIC CHIP 0.01μF	50V
C2546	1-117-828-31	FILM 3300PF	3% 1.5KV	C2626	1-104-653-11	ELECT 220μF	20% 6.3V
C2549	1-163-031-11	CERAMIC CHIP 0.01μF	50V	C2627	1-164-004-11	CERAMIC CHIP 0.1μF	10% 25V
C2550	1-164-004-11	CERAMIC CHIP 0.1μF	10% 25V	C2628	1-164-004-11	CERAMIC CHIP 0.1μF	10% 25V

Ref.No.	Part No.	Description	Remark	Ref.No.	Part No.	Description	Remark
C2631	1-127-573-91	CERAMIC CHIP 1μF	10% 16V	CN2504	* 1-793-239-11	PIN, CONNECTOR (PC BOARD) 6P	
C3501	1-163-133-00	CERAMIC CHIP 470PF	5% 50V	CN2505	* 1-564-507-11	PLUG, CONNECTOR 4P	
C3502	1-107-877-11	ELECT 1000μF	20% 10V	CN2506	* 1-564-711-11	PIN, CONNECTOR (SMALL TYPE) 9P	
C3503	1-163-021-91	CERAMIC CHIP 0.01μF	50V	CN2601	* 1-564-710-11	PIN, CONNECTOR (SMALL TYPE) 8P	
C3504	1-163-021-91	CERAMIC CHIP 0.01μF	50V	CN2602	* 1-564-710-11	PIN, CONNECTOR (SMALL TYPE) 8P	
C3505	1-125-838-91	CERAMIC CHIP 2.2μF	10% 6.3V			<DIODE>	
C3506	1-125-838-91	CERAMIC CHIP 2.2μF	10% 6.3V	D1601	8-719-210-43	DIODE EC10QS-06	
C3509	1-164-004-11	CERAMIC CHIP 0.1μF	10% 25V	D1602	8-719-073-01	DIODE MA111-(K8).S0	
C3510	1-125-838-91	CERAMIC CHIP 2.2μF	10% 6.3V	D1603	8-719-978-24	DIODE DTZ-TT11-5.6A	
C3511	1-163-021-91	CERAMIC CHIP 0.01μF	50V	D1604	8-719-158-57	DIODE RD15SB2	
C3512	1-125-838-91	CERAMIC CHIP 2.2μF	10% 6.3V	D1605	8-719-037-00	DIODE RD6.2SB2-T1	
C3513	1-163-227-11	CERAMIC CHIP 10PF	0.5PF 50V	D1606	8-719-037-00	DIODE RD6.2SB2-T1	
C3515	1-164-004-11	CERAMIC CHIP 0.1μF	10% 25V	D1607	8-719-073-01	DIODE MA111-(K8).S0	
C3516	1-163-031-11	CERAMIC CHIP 0.01μF	50V	D1608	8-719-073-01	DIODE MA111-(K8).S0	
C3517	1-125-838-91	CERAMIC CHIP 2.2μF	10% 6.3V	D1609	8-719-073-01	DIODE MA111-(K8).S0	
C3518	1-163-227-11	CERAMIC CHIP 10PF	0.5PF 50V	D1610	8-719-037-39	DIODE RD18SB2-T1	
C3519	1-125-838-91	CERAMIC CHIP 2.2μF	10% 6.3V	D1611	8-719-059-22	DIODE NSQ03A06-TE16L	
C3520	1-125-838-91	CERAMIC CHIP 2.2μF	10% 6.3V	D2501	8-719-988-72	DIODE SC802-06	
C3521	1-163-251-11	CERAMIC CHIP 100PF	5% 50V	D2504	8-719-073-01	DIODE MA111-(K8).S0	
C3522	1-163-021-91	CERAMIC CHIP 0.01μF	10% 50V	D2505	8-719-029-04	DIODE D5L60	
C3523	1-127-820-91	CERAMIC 4.7μF	0 16V	D2506	8-719-073-01	DIODE MA111-(K8).S0	
C3524	1-104-664-11	ELECT 47μF	20% 16V	D2507	8-719-073-01	DIODE MA111-(K8).S0	
C3526	1-128-526-11	ELECT 100μF	20% 16V	D2509	8-719-977-95	DIODE DTZ-TT11-2.4B	
C3527	1-163-021-91	CERAMIC CHIP 0.01μF	10% 50V	D2511	8-719-158-49	DIODE RD12SB2	
C3529	1-137-374-11	MYLAR 0.047μF	5% 50V	D2512	8-719-158-49	DIODE RD12SB2	
C3531	1-163-275-11	CERAMIC 0.001μF	5% 50V	D2513	8-719-073-01	DIODE MA111-(K8).S0	
C3601	1-163-031-11	CERAMIC CHIP 0.01μF	50V	D2515	8-719-073-01	DIODE MA111-(K8).S0	
C3602	1-163-037-11	CERAMIC CHIP 0.022μF	10% 50V	D2516	8-719-158-49	DIODE RD12SB2	
C3603	1-164-505-11	CERAMIC CHIP 2.2μF	16V	D2517	8-719-073-01	DIODE MA111-(K8).S0	
C3604	1-163-251-11	CERAMIC CHIP 100PF	5% 50V	D2519	8-719-073-01	DIODE MA111-(K8).S0	
C3605	1-163-131-00	CERAMIC CHIP 390PF	5% 50V	D2520	8-719-073-01	DIODE MA111-(K8).S0	
C3606	1-163-031-11	CERAMIC CHIP 0.01μF	50V	D2521	8-719-073-01	DIODE MA111-(K8).S0	
C3607	1-163-037-11	CERAMIC CHIP 0.022μF	10% 50V	D2522	8-719-158-49	DIODE RD12SB2	
C3608	1-163-251-11	CERAMIC CHIP 100PF	5% 50V	D2523	8-719-988-72	DIODE SC802-06	
C3609	1-128-077-11	ELECT 22μF	20% 25V	D2524	8-719-073-01	DIODE MA111-(K8).S0	
C3610	1-165-319-11	CERAMIC CHIP 0.1μF	50V	D2525	8-719-073-01	DIODE MA111-(K8).S0	
C3611	1-126-096-11	ELECT 10μF	20% 35V	D2526	8-719-073-01	DIODE MA111-(K8).S0	
C3612	1-107-914-11	ELECT 1000μF	20% 25V	D2527	8-719-159-13	DIODE RD5.1SB3-T2	
C3613	1-163-031-11	CERAMIC CHIP 0.01μF	50V	D2528	8-719-073-01	DIODE MA111-(K8).S0	
C3614	1-107-884-11	ELECT 1000μF	20% 16V	D2529	8-719-073-01	DIODE MA111-(K8).S0	
C3615	1-163-031-11	CERAMIC CHIP 0.01μF	50V	D2530	8-719-073-01	DIODE MA111-(K8).S0	
C3616	1-128-526-11	ELECT 100μF	20% 16V	D2532	8-719-033-53	DIODE RD6.8SB2-T1	
C3617	1-163-031-11	CERAMIC CHIP 0.01μF	50V	D2533	8-719-951-30	DIODE ERA91-02	
C3618	1-107-909-11	ELECT 47μF	20% 35V	D2601	8-719-059-22	DIODE NSQ03A06-TE16L	
C3619	1-107-914-11	ELECT 1000μF	20% 25V	D2602	8-719-037-39	DIODE RD18SB2-T1	
C3620	1-163-031-11	CERAMIC CHIP 0.01μF	50V	D2604	8-719-059-22	DIODE NSQ03A06-TE16L	
C3621	1-128-528-11	ELECT 470μF	20% 16V	D2605	8-719-037-39	DIODE RD18SB2-T1	
C3622	1-163-031-11	CERAMIC CHIP 0.01μF	50V	D3601	8-719-059-22	DIODE NSQ03A06-TE16L	
C3623	1-104-653-11	ELECT 220μF	20% 16V	D3603	8-719-210-43	DIODE EC10QS-06	
C3624	1-104-653-11	ELECT 220μF	20% 16V	D3604	8-719-059-22	DIODE NSQ03A06-TE16L	
C3625	1-128-526-11	ELECT 100μF	20% 16V	D3605	8-719-210-43	DIODE EC10QS-06	
C3626	1-163-031-11	CERAMIC CHIP 0.01μF	50V	D3606	8-719-210-43	DIODE EC10QS-06	
C3627	1-164-004-11	CERAMIC CHIP 0.1μF	10% 25V	D3607	8-719-059-22	DIODE NSQ03A06-TE16L	
C3628	1-164-004-11	CERAMIC CHIP 0.1μF	10% 25V	D3608	8-719-037-39	DIODE RD18SB2-T1	
C3629	1-107-884-11	ELECT 1000μF	20% 16V	D3609	8-719-037-39	DIODE RD18SB2-T1	
C3630	1-128-526-11	ELECT 100μF	20% 16V			<FUSE>	
C3631	1-127-573-91	CERAMIC CHIP 1μF	10% 16V	F1601	△ 1-576-048-11	FUSE, GLASS TUBE 10A/125V	
C3632	1-128-526-11	ELECT 100μF	20% 16V	F1602	△ 1-576-048-11	FUSE, GLASS TUBE 10A/125V	
		<CONNECTOR>					
CN1601	* 1-766-175-11	PIN, CONNECTOR (PC BOARD) 5P					
CN1602	* 1-580-843-11	PIN, CONNECTOR (POWER)					
CN2501	* 1-564-714-11	PIN, CONNECTOR (SMALL TYPE) 12P					
CN2502	* 1-564-510-11	PLUG, CONNECTOR 7P					
CN2503	* 1-564-712-11	PIN, CONNECTOR (SMALL TYPE) 10P					



Ref.No.	Part No.	Description	Remark	Ref.No.	Part No.	Description	Remark
<FUSE HOLDER>				Q1608	1-801-806-11	TRANSISTOR DTC144EKA-T146	
FH1	△ 1-533-183-11	HOLDER, FUSE		Q1609	1-801-806-11	TRANSISTOR DTC144EKA-T146	
FH2	△ 1-533-183-11	HOLDER, FUSE		Q1610	1-801-806-11	TRANSISTOR DTC144EKA-T146	
FH3	△ 1-533-183-11	HOLDER, FUSE		Q1611	8-729-120-28	TRANSISTOR 2SC1623-L5L6	
FH4	△ 1-533-183-11	HOLDER, FUSE		Q1612	8-729-824-24	TRANSISTOR 2SA1338-5-TB	
<IC>				Q1613	8-729-019-85	TRANSISTOR 2SC3392-5-TB	
IC1601	8-759-908-15	IC TL431CLP		Q1614	8-729-041-37	TRANSISTOR 2SJ377(TE16L)	
IC1602	8-759-261-48	IC TL1451ACPWR		Q1617	8-729-027-38	TRANSISTOR DTA144EKA-T146	
IC2501	8-752-072-94	IC CXA1875AM-T4		Q2502	8-729-925-42	TRANSISTOR IMT2	
IC2502	8-752-072-94	IC CXA1875AM-T4		Q2503	8-729-925-42	TRANSISTOR IMT2	
IC2503	8-759-593-29	IC TDA9106		Q2507	8-729-019-85	TRANSISTOR 2SC3392-5-TB	
IC2504	8-759-980-58	IC TDA8172		Q2508	8-729-824-24	TRANSISTOR 2SA1338-5-TB	
IC2505	8-759-239-34	IC TC74HC4538AF		Q2509	8-729-926-77	TRANSISTOR IRF1640	
IC2506	8-759-981-48	IC TL082M		Q2510	8-729-026-50	TRANSISTOR 2SA1037AK-T146-QR	
IC2507	8-759-803-42	IC LA6500-FA		Q2511	8-729-033-25	TRANSISTOR DTC114GKA	
IC2508	8-759-209-90	IC TC4S71F		Q2512	8-729-019-85	TRANSISTOR 2SC3392-5-TB	
IC2509	8-759-239-34	IC TC74HC4538AF		Q2513	8-729-824-24	TRANSISTOR 2SA1338-5-TB	
IC2510	8-759-981-48	IC TL082M		Q2514	8-729-048-07	TRANSISTOR 2SD2578-CA	
IC2512	8-759-981-48	IC TL082M		Q2516	8-729-800-32	TRANSISTOR 2SC2362K-G	
IC2513	8-759-239-34	IC TC74HC4538AF		Q2517	8-729-026-49	TRANSISTOR 2SA1037AK-T146-R	
IC2514	8-759-209-69	IC TC4S11F		Q2519	8-729-050-72	TRANSISTOR 2SK2231-TP	
IC2515	8-759-209-69	IC TC4S11F		Q2520	8-729-050-72	TRANSISTOR 2SK2231-TP	
IC2516	8-759-231-30	IC TC-4S30F		Q2521	8-729-900-53	TRANSISTOR DTC114EK	
IC2517	8-759-231-30	IC TC-4S30F		Q2522	1-801-806-11	TRANSISTOR DTC144EKA-T146	
IC2518	8-759-100-96	IC UPC4558G2		Q2523	1-801-806-11	TRANSISTOR DTC144EKA-T146	
IC2519	8-759-981-48	IC TL082M		Q2524	8-729-027-38	TRANSISTOR DTA144EKA-T146	
IC2521	8-759-209-69	IC TC4S11F		Q2525	8-729-120-28	TRANSISTOR 2SC1623-L5L6	
IC2522	8-759-209-69	IC TC4S11F		Q2526	1-801-806-11	TRANSISTOR DTC144EKA-T146	
IC2523	8-759-239-34	IC TC74HC4538AF		Q2527	8-729-120-28	TRANSISTOR 2SC1623-L5L6	
IC2601	8-759-261-48	IC TL1451ACPWR		Q2528	1-801-806-11	TRANSISTOR DTC144EKA-T146	
IC2602	8-759-450-47	IC BA05T		Q2529	8-729-027-38	TRANSISTOR DTA144EKA-T146	
IC2603	8-759-247-67	IC LM2990T-5.0		Q2530	1-801-806-11	TRANSISTOR DTC144EKA-T146	
IC3601	8-759-261-48	IC TL1451ACPWR		Q2531	8-729-027-38	TRANSISTOR DTA144EKA-T146	
<COIL>				Q2532	1-801-806-11	TRANSISTOR DTC144EKA-T146	
L1601	1-419-396-11	INDUCTOR	47μH	Q2533	1-801-806-11	TRANSISTOR DTC144EKA-T146	
L1603	1-469-563-11	INDUCTOR	5.6μH	Q2534	1-801-806-11	TRANSISTOR DTC144EKA-T146	
L1604	1-406-660-41	INDUCTOR	15μH	Q2535	8-729-050-72	TRANSISTOR 2SK2231-TP	
L2501	1-410-482-31	INDUCTOR	100μH	Q2601	1-801-806-11	TRANSISTOR DTC144EKA-T146	
L2502	1-410-482-31	INDUCTOR	100μH	Q2602	1-801-806-11	TRANSISTOR DTC144EKA-T146	
L2503	1-406-975-21	INDUCTOR	47μH	Q2603	1-801-806-11	TRANSISTOR DTC144EKA-T146	
L2504	1-419-437-11	CHOKE		Q2604	8-729-120-28	TRANSISTOR 2SC1623-L5L6	
L2505	1-419-307-11	COIL, HORIZONTAL LINEARITY		Q2605	8-729-824-24	TRANSISTOR 2SA1338-5-TB	
L2506	1-408-623-31	INDUCTOR	470μH	Q2606	8-729-019-85	TRANSISTOR 2SC3392-5-TB	
L2509	1-419-305-11	COIL, HORIZONTAL LINEARITY		Q2607	8-729-041-37	TRANSISTOR 2SJ377(TE16L)	
L2510	1-410-067-21	INDUCTOR	4.7mH	Q2609	8-729-120-28	TRANSISTOR 2SC1623-L5L6	
L2511	1-406-661-11	INDUCTOR	22μH	Q2610	8-729-824-24	TRANSISTOR 2SA1338-5-TB	
L2601	1-419-397-11	INDUCTOR	68μH	Q2611	8-729-019-85	TRANSISTOR 2SC3392-5-TB	
L2603	1-406-660-41	INDUCTOR	15μH	Q2612	8-729-041-37	TRANSISTOR 2SJ377(TE16L)	
L2604	1-419-397-11	INDUCTOR	68μH	Q3601	1-801-806-11	TRANSISTOR DTC144EKA-T146	
L2605	1-406-660-41	INDUCTOR	15μH	Q3602	1-801-806-11	TRANSISTOR DTC144EKA-T146	
L3601	1-406-665-11	INDUCTOR	100μH	Q3603	1-801-806-11	TRANSISTOR DTC144EKA-T146	
L3602	1-419-398-11	INDUCTOR	220μH	Q3604	8-729-120-28	TRANSISTOR 2SC1623-L5L6	
L3603	1-406-667-41	INDUCTOR	220μH	Q3605	8-729-824-24	TRANSISTOR 2SA1338-5-TB	
<TRANSISTOR>				Q3606	8-729-019-85	TRANSISTOR 2SC3392-5-TB	
Q1601	8-729-920-59	TRANSISTOR IMX2-T109		Q3607	8-729-041-37	TRANSISTOR 2SJ377(TE16L)	
Q1602	8-729-027-23	TRANSISTOR DTA114EKA-T146		Q3609	8-729-050-72	TRANSISTOR 2SK2231-TP	
Q1603	8-729-027-23	TRANSISTOR DTA114EKA-T146		Q3610	8-729-120-28	TRANSISTOR 2SC1623-L5L6	
Q1604	1-801-806-11	TRANSISTOR DTC144EKA-T146		Q3611	8-729-824-24	TRANSISTOR 2SA1338-5-TB	
Q1605	8-729-027-38	TRANSISTOR DTA144EKA-T146		Q3612	8-729-019-85	TRANSISTOR 2SC3392-5-TB	
<RESISTOR>				Q3613	8-729-041-37	TRANSISTOR 2SJ377(TE16L)	
R1601	1-216-677-11	METAL CHIP	12K 0.50% 1/10W				
R1602	1-216-682-11	METAL CHIP	20K 0.50% 1/10W				



Ref.No.	Part No.	Description	Remark	Ref.No.	Part No.	Description	Remark
R1603	1-216-677-11	METAL CHIP	12K 0.50% 1/10W	R2542	1-216-359-00	METAL OXIDE	6.8 5% 1W F
R1605	1-216-065-91	RES,CHIP	4.7K 5% 1/10W	R2543	1-216-359-00	METAL OXIDE	6.8 5% 1W F
R1606	1-216-055-00	RES,CHIP	1.8K 5% 1/10W	R2545	1-202-933-61	FUSIBLE	0.1 10% 1/2W F
R1607	1-216-073-00	RES,CHIP	10K 5% 1/10W	R2550	1-216-073-00	RES,CHIP	10K 5% 1/10W
R1608	1-216-057-00	RES,CHIP	2.2K 5% 1/10W	R2551	1-216-001-00	RES,CHIP	10 5% 1/10W
R1609	1-216-057-00	RES,CHIP	2.2K 5% 1/10W	R2552	1-216-699-91	METAL CHIP	100K 0.50% 1/10W
R1611	1-216-667-11	METAL CHIP	4.7K 0.50% 1/10W	R2553	1-216-679-91	RES,CHIP	15K 5% 1/10W
R1612	1-216-667-11	METAL CHIP	4.7K 0.50% 1/10W	R2554	1-216-067-00	RES,CHIP	5.6K 5% 1/10W
R1613	1-216-099-00	RES,CHIP	120K 5% 1/10W	R2555	1-216-073-00	RES,CHIP	10K 5% 1/10W
R1614	1-216-073-00	RES,CHIP	10K 5% 1/10W	R2556	1-216-065-91	RES,CHIP	4.7K 5% 1/10W
R1615	1-216-093-91	RES,CHIP	68K 5% 1/10W	R2557	1-216-001-00	RES,CHIP	10 5% 1/10W
R1616	1-216-667-11	METAL CHIP	4.7K 0.50% 1/10W	R2558	1-216-073-00	RES,CHIP	10K 5% 1/10W
R1617	1-216-685-11	METAL CHIP	27K 0.50% 1/10W	R2559	1-216-073-00	RES,CHIP	10K 5% 1/10W
R1618	1-216-677-11	METAL CHIP	12K 0.50% 1/10W	R2560	1-216-659-11	METAL CHIP	2.2K 0.50% 1/10W
R1619	1-216-659-11	METAL CHIP	2.2K 0.50% 1/10W	R2561	1-216-065-91	RES,CHIP	4.7K 5% 1/10W
R1620	1-216-667-11	METAL CHIP	4.7K 0.50% 1/10W	R2562	1-216-053-00	RES,CHIP	1.5K 5% 1/10W
R1621	1-216-667-11	METAL CHIP	4.7K 0.50% 1/10W	R2563	1-216-073-00	RES,CHIP	10K 5% 1/10W
R1624	1-216-667-11	METAL CHIP	4.7K 0.50% 1/10W	R2564	1-216-369-00	METAL OXIDE	1 5% 2W F
R1625	1-216-089-91	RES,CHIP	47K 5% 1/10W	R2565	1-249-381-11	CARBON	1 5% 1/4W F
R1626	1-216-065-91	RES,CHIP	4.7K 5% 1/10W	R2566	1-216-049-91	RES,CHIP	1K 5% 1/10W
R1627	1-216-065-91	RES,CHIP	4.7K 5% 1/10W	R2568	1-216-037-00	RES,CHIP	330 5% 1/10W
R1628	1-216-009-91	RES,CHIP	22 5% 1/10W	R2569	1-249-429-11	CARBON	10K 5% 1/4W
R1629	1-216-065-91	RES,CHIP	4.7K 5% 1/10W	R2570	1-216-069-00	RES,CHIP	6.8K 5% 1/10W
R1630	1-249-377-11	CARBON	0.47 5% 1/4W F	R2571	1-216-073-00	RES,CHIP	10K 5% 1/10W
R1631	1-249-377-11	CARBON	0.47 5% 1/4W F	R2572	1-216-097-91	RES,CHIP	100K 5% 1/10W
R1632	1-216-065-91	RES,CHIP	4.7K 5% 1/10W	R2573	1-215-887-00	METAL OXIDE	150 5% 2W F
R2501	1-216-073-00	RES,CHIP	10K 5% 1/10W	R2575	1-249-403-11	CARBON	68 5% 1/4W F
R2502	1-216-073-00	RES,CHIP	10K 5% 1/10W	R2576	1-216-482-11	METAL OXIDE	1.8K 5% 3W F
R2503	1-216-073-00	RES,CHIP	10K 5% 1/10W	R2577	1-216-425-11	METAL OXIDE	56 5% 1W F
R2504	1-216-073-00	RES,CHIP	10K 5% 1/10W	R2578	1-216-424-11	METAL OXIDE	39 5% 1W F
R2505	1-216-025-91	RES,CHIP	100 5% 1/10W	R2579	1-216-089-91	RES,CHIP	47K 5% 1/10W
R2506	1-216-651-11	METAL CHIP	1K 0.50% 1/10W	R2580	1-216-089-91	RES,CHIP	47K 5% 1/10W
R2507	1-216-683-11	METAL CHIP	22K 0.50% 1/10W	R2581	1-216-089-91	RES,CHIP	47K 5% 1/10W
R2508	1-216-001-00	RES,CHIP	10 5% 1/10W	R2582	1-216-089-91	RES,CHIP	47K 5% 1/10W
R2509	1-216-673-11	METAL CHIP	8.2K 0.50% 1/10W	R2584	1-216-049-91	RES,CHIP	1K 5% 1/10W
R2510	1-216-043-91	RES,CHIP	560 5% 1/10W	R2589	1-249-429-11	CARBON	10K 5% 1/4W
R2511	1-216-073-00	RES,CHIP	10K 5% 1/10W	R2590	1-216-081-00	RES,CHIP	22K 5% 1/10W
R2512	1-216-049-91	RES,CHIP	1K 5% 1/10W	R2591	1-216-097-91	RES,CHIP	100K 5% 1/10W
R2513	1-216-079-00	RES,CHIP	18K 5% 1/10W	R2592	1-216-089-91	RES,CHIP	47K 5% 1/10W
R2514	1-216-041-00	RES,CHIP	470 5% 1/10W	R2593	1-249-435-11	CARBON	33K 5% 1/4W
R2515	1-216-073-00	RES,CHIP	10K 5% 1/10W	R2594	1-249-417-11	CARBON	1K 5% 1/4W
R2516	1-216-073-00	RES,CHIP	10K 5% 1/10W	R2595	1-216-089-91	RES,CHIP	47K 5% 1/10W
R2517	1-216-049-91	RES,CHIP	1K 5% 1/10W	R2596	1-216-073-00	RES,CHIP	10K 5% 1/10W
R2518	1-216-041-00	RES,CHIP	470 5% 1/10W	R2597	1-216-097-91	RES,CHIP	100K 5% 1/10W
R2519	1-216-073-00	RES,CHIP	10K 5% 1/10W	R2598	1-216-089-91	RES,CHIP	47K 5% 1/10W
R2520	1-216-693-11	METAL CHIP	56K 0.50% 1/10W	R2599	1-216-089-91	RES,CHIP	47K 5% 1/10W
R2521	1-215-863-11	METAL OXIDE	100 5% 1W F	R2601	1-216-667-11	METAL CHIP	4.7K 0.50% 1/10W
R2524	1-216-085-00	RES,CHIP	33K 5% 1/10W	R2602	1-216-667-11	METAL CHIP	4.7K 0.50% 1/10W
R2525	1-216-677-11	METAL CHIP	12K 0.50% 1/10W	R2603	1-216-099-00	RES,CHIP	120K 5% 1/10W
R2526	1-216-069-00	RES,CHIP	6.8K 5% 1/10W	R2604	1-216-073-00	RES,CHIP	10K 5% 1/10W
R2527	1-216-073-00	RES,CHIP	10K 5% 1/10W	R2605	1-216-093-91	RES,CHIP	68K 5% 1/10W
R2528	1-216-111-00	RES,CHIP	390K 5% 1/10W	R2606	1-216-667-11	METAL CHIP	4.7K 0.50% 1/10W
R2529	1-216-113-00	RES,CHIP	470K 5% 1/10W	R2607	1-216-685-11	METAL CHIP	27K 0.50% 1/10W
R2530	1-216-073-00	RES,CHIP	10K 5% 1/10W	R2608	1-216-662-11	METAL CHIP	3K 0.50% 1/10W
R2531	1-216-077-91	RES,CHIP	15K 5% 1/10W	R2609	1-216-679-11	METAL CHIP	15K 0.50% 1/10W
R2532	1-216-077-91	RES,CHIP	15K 5% 1/10W	R2610	1-216-667-11	METAL CHIP	4.7K 0.50% 1/10W
R2533	1-216-097-91	RES,CHIP	100K 5% 1/10W	R2611	1-216-667-11	METAL CHIP	4.7K 0.50% 1/10W
R2534	1-249-393-11	CARBON	10 5% 1/4W F	R2612	1-216-073-00	RES,CHIP	10K 5% 1/10W
R2535	1-249-393-11	CARBON	10 5% 1/4W F	R2613	1-216-684-91	METAL CHIP	24K 0.50% 1/10W
R2536	1-216-676-11	METAL CHIP	11K 0.50% 1/10W	R2614	1-216-667-11	METAL CHIP	4.7K 0.50% 1/10W
R2537	1-216-067-00	RES,CHIP	5.6K 5% 1/10W	R2615	1-216-663-11	METAL CHIP	3.3K 0.50% 1/10W
R2538	1-249-383-11	CARBON	1.5 5% 1/4W F	R2616	1-216-089-91	RES,CHIP	47K 5% 1/10W
R2539	1-216-067-00	RES,CHIP	5.6K 5% 1/10W	R2617	1-216-065-91	RES,CHIP	4.7K 5% 1/10W
R2540	1-216-676-11	METAL CHIP	11K 0.50% 1/10W	R2618	1-216-065-91	RES,CHIP	4.7K 5% 1/10W
R2541	1-216-431-11	METAL OXIDE	560 5% 1W F	R2619	1-216-009-91	RES,CHIP	22 5% 1/10W

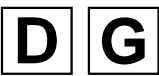

Ref.No.	Part No.	Description	Remark
R2620	1-216-065-91	RES,CHIP 4.7K	5% 1/10W
R2625	1-216-065-91	RES,CHIP 4.7K	5% 1/10W
R2626	1-216-065-91	RES,CHIP 4.7K	5% 1/10W
R2627	1-216-009-91	RES,CHIP 22	5% 1/10W
R2628	1-216-065-91	RES,CHIP 4.7K	5% 1/10W
R2629	1-249-377-11	CARBON 0.47	5% 1/4W F
R2630	1-249-377-11	CARBON 0.47	5% 1/4W F
R3500	1-216-675-91	METAL CHIP 10K	0.50% 1/10W
R3501	1-216-053-00	RES,CHIP 1.5K	5% 1/10W
R3502	1-216-673-11	METAL CHIP 8.2K	0.50% 1/10W
R3503	1-216-695-11	METAL CHIP 68K	0.50% 1/10W
R3504	1-218-754-11	METAL CHIP 120K	0.50% 1/10W
R3505	1-249-431-11	CARBON 15K	5% 1/4W
R3506	1-216-065-91	RES,CHIP 4.7K	5% 1/10W
R3507	1-216-073-00	RES,CHIP 10K	5% 1/10W
R3508	1-216-073-00	RES,CHIP 10K	5% 1/10W
R3509	1-216-049-91	RES,CHIP 1K	5% 1/10W
R3510	1-216-025-91	RES,CHIP 100	5% 1/10W
R3511	1-216-025-91	RES,CHIP 100	5% 1/10W
R3512	1-216-685-11	METAL CHIP 27K	0.50% 1/10W
R3513	1-216-049-91	RES,CHIP 1K	5% 1/10W
R3514	1-216-065-91	RES,CHIP 4.7K	5% 1/10W
R3515	1-216-025-91	RES,CHIP 100	5% 1/10W
R3516	1-216-073-00	RES,CHIP 10K	5% 1/10W
R3517	1-216-073-00	RES,CHIP 10K	5% 1/10W
R3518	1-216-073-00	RES,CHIP 10K	5% 1/10W
R3519	1-216-059-00	RES,CHIP 2.7K	5% 1/10W
R3520	1-216-073-00	RES,CHIP 10K	5% 1/10W
R3521	1-216-113-00	RES,CHIP 470K	5% 1/10W
R3522	1-216-073-00	RES,CHIP 10K	5% 1/10W
R3525	1-216-025-91	RES,CHIP 100	5% 1/10W
R3526	1-216-025-91	RES,CHIP 100	5% 1/10W
R3527	1-216-113-00	RES,CHIP 470K	5% 1/10W
R3528	1-216-049-91	RES,CHIP 1K	5% 1/10W
R3529	1-216-697-91	METAL CHIP 82K	0.50% 1/10W
R3530	1-216-679-11	METAL CHIP 15K	0.50% 1/10W
R3531	1-216-049-91	RES,CHIP 1K	5% 1/10W
R3532	1-216-089-91	RES,CHIP 47K	5% 1/10W
R3533	1-216-065-91	RES,CHIP 4.7K	5% 1/10W
R3534	1-216-049-91	RES,CHIP 1K	5% 1/10W
R3535	1-216-057-00	RES,CHIP 2.2K	5% 1/10W
R3545	1-216-057-00	RES,CHIP 2.2K	5% 1/10W
R3546	1-216-081-00	RES,CHIP 22K	5% 1/10W
R3547	1-216-091-00	RES,CHIP 56K	5% 1/10W
R3548	1-216-049-91	RES,CHIP 1K	5% 1/10W
R3550	1-216-093-91	RES,CHIP 68K	5% 1/10W
R3551	1-216-453-00	METAL OXIDE 270	5% 2W F
R3552	1-216-475-11	METAL OXIDE 120	5% 3W F
R3553	1-216-346-00	METAL OXIDE 0.56	5% 1W F
R3554	1-215-861-00	METAL OXIDE 47	5% 1W F
R3556	1-216-107-00	RES,CHIP 270K	5% 1/10W
R3557	1-216-073-00	RES,CHIP 10K	5% 1/10W
R3558	1-216-061-00	RES,CHIP 3.3K	5% 1/10W
R3560	1-216-073-00	RES,CHIP 10K	5% 1/10W
R3601	1-216-667-11	METAL CHIP 4.7K	0.50% 1/10W
R3602	1-216-667-11	METAL CHIP 4.7K	0.50% 1/10W
R3603	1-216-099-00	RES,CHIP 120K	5% 1/10W
R3604	1-216-073-00	RES,CHIP 10K	5% 1/10W
R3605	1-216-093-91	RES,CHIP 68K	5% 1/10W
R3606	1-216-667-11	METAL CHIP 4.7K	0.50% 1/10W
R3607	1-216-685-11	METAL CHIP 27K	0.50% 1/10W
R3608	1-216-689-11	METAL CHIP 39K	0.50% 1/10W
R3609	1-216-655-11	METAL CHIP 1.5K	0.50% 1/10W
R3610	1-216-667-11	METAL CHIP 4.7K	0.50% 1/10W
R3611	1-216-667-11	METAL CHIP 4.7K	0.50% 1/10W
R3612	1-216-073-00	RES,CHIP 10K	5% 1/10W

Ref.No.	Part No.	Description	Remark
R3613	1-216-691-11	METAL CHIP 47K	0.50% 1/10W
R3614	1-216-667-11	METAL CHIP 4.7K	0.50% 1/10W
R3615	1-216-662-11	METAL CHIP 3K	0.50% 1/10W
R3616	1-216-089-91	RES,CHIP 47K	5% 1/10W
R3617	1-216-065-91	RES,CHIP 4.7K	5% 1/10W
R3618	1-216-065-91	RES,CHIP 4.7K	5% 1/10W
R3619	1-216-009-91	RES,CHIP 22	5% 1/10W
R3620	1-216-065-91	RES,CHIP 4.7K	5% 1/10W
R3621	1-216-009-91	RES,CHIP 22	5% 1/10W
R3622	1-216-065-91	RES,CHIP 4.7K	5% 1/10W
R3627	1-216-065-91	RES,CHIP 4.7K	5% 1/10W
R3628	1-216-065-91	RES,CHIP 4.7K	5% 1/10W
R3629	1-216-009-91	RES,CHIP 22	5% 1/10W
R3630	1-216-065-91	RES,CHIP 4.7K	5% 1/10W
R3631	1-249-425-11	CARBON 4.7K	5% 1/4W F
R3632	1-249-413-11	CARBON 470	5% 1/4W F
R3633	1-249-413-11	CARBON 470	5% 1/4W F
R3634	1-249-377-11	CARBON 0.47	5% 1/4W F
R3635	1-249-377-11	CARBON 0.47	5% 1/4W F
R3636	1-249-393-11	CARBON 10	5% 1/4W F
R3637	1-249-381-11	CARBON 1	5% 1/4W F
R3638	1-249-381-11	CARBON 1	5% 1/4W F
<RELAY>			
RY1601	1-755-018-11	RELAY	
RY2501	1-755-198-11	RELAY, AC POWER	
<TRANSFORMER>			
T2501	1-419-437-11	CHOKE	
T2502	1-431-443-11	TRANSFORMER, FERRITE (HST)	
T2503	1-433-978-11	TRANSFORMER, HORIZONTAL DRIVE	
T2504	1-419-438-11	CHOKE	
T3601	1-435-157-11	TRANSFORMER, DC-DC CONVERTER	
*****			
		* A-1316-460-A	G COMPL
			*****
		4-382-854-01	SCREW(M3X8), P, SW (+)
<CAPACITOR>			
C601	△ 1-113-900-11	CERAMIC 470PF	10% 250V
C602	△ 1-104-708-11	MYLAR 0.47μF	20% 250V
C603	△ 1-104-706-11	MYLAR 0.22μF	20% 250V
C604	△ 1-113-926-11	CERAMIC 0.0047μF	250V
C605	△ 1-113-900-11	CERAMIC 470PF	10% 250V
C606	△ 1-113-926-11	CERAMIC 0.0047μF	250V
C611	1-107-907-11	ELECT 22μF	20% 50V
C613	1-107-905-11	ELECT 4.7μF	20% 50V
C614	1-107-910-11	ELECT 100μF	20% 50V
C615	1-131-913-11	ELECT 150μF	20% 450V
C616	1-130-495-00	MYLAR 0.1μF	5% 50V
C618	1-131-876-91	CAPACITOR 000000000	0 0
C620	1-107-910-11	ELECT 100μF	20% 50V
C621	1-107-906-11	ELECT 10μF	20% 50V
C622	1-107-909-11	ELECT 47μF	20% 50V
C623	1-127-825-11	FILM 0.0033μF	3% 1KV
C629	1-163-251-11	CERAMIC CHIP 100PF	5% 50V
C630	1-137-479-71	MYLAR 1μF	10% 400V
C631	1-115-340-11	CERAMIC CHIP 0.22μF	10% 25V
C632	1-107-910-11	ELECT 100μF	20% 50V

Ref.No.	Part No.	Description	Remark	Ref.No.	Part No.	Description	Remark
C637	1-107-910-11	ELECT 100μF 20%	50V	R653	1-215-485-00	METAL 470K	1% 1/4W
C644	1-127-825-11	FILM 0.0033μF 3%	1KV	R657	1-216-677-11	METAL CHIP 12K	0.50% 1/10W
C651	1-163-021-91	CERAMIC CHIP 0.01μF 10%	50V	R658	1-216-651-11	METAL CHIP 1K	0.50% 1/10W
C690	1-111-074-11	ELECT 0.0039F 20%	25V	R668	△1-242-803-11	CEMENTED 1.5	5% 7W
C691	1-111-074-11	ELECT 0.0039F 20%	25V	R669	△1-242-803-11	CEMENTED 1.5	5% 7W
C693	1-126-942-61	ELECT 1000μF 20%	25V	R670	1-217-192-21	METAL 0.22	10% 2W
<CONNECTOR>				R671	1-217-192-21	METAL 0.22	10% 2W
CN601	* 1-691-960-11	PIN, CONNECTOR (PC BOARD) 3P		R672	1-215-926-00	METAL OXIDE 33K	5% 3W F
CN690	* 1-580-843-11	PIN, CONNECTOR (POWER)		R673	1-215-926-00	METAL OXIDE 33K	5% 3W F
CN691	1-695-915-11	TAB (CONTACT)		R674	1-249-377-11	CARBON 0.47	5% 1/4W F
<DIODE>				R675	1-216-073-00	RES,CHIP 10K	5% 1/10W
D601	8-719-510-53	DIODE D4SB60L		R677	1-216-346-00	METAL OXIDE 0.56	5% 1W F
D602	8-719-304-63	DIODE RM11C		R678	1-260-135-11	CARBON 1M	5% 1/2W
D604	8-719-989-76	DIODE SC802-04		R679	1-260-135-11	CARBON 1M	5% 1/2W
D605	8-719-989-21	DIODE SC311-6-TE12RA		R680	1-260-135-11	CARBON 1M	5% 1/2W
D606	8-719-989-21	DIODE SC311-6-TE12RA		R681	1-260-135-11	CARBON 1M	5% 1/2W
D607	8-719-989-21	DIODE SC311-6-TE12RA		R688	1-215-926-00	METAL OXIDE 33K	5% 3W F
D620	8-719-063-73	DIODE D1NL20U-TR		R690	1-249-410-11	CARBON 270	5% 1/4W F
D661	8-719-158-53	DIODE RD13SB2		R691	1-216-057-00	RES,CHIP 2.2K	5% 1/10W
D662	8-719-063-73	DIODE D1NL20U-TR		R692	1-216-049-91	RES,CHIP 1K	5% 1/10W
D663	8-719-063-73	DIODE D1NL20U-TR		R693	1-249-401-11	CARBON 47	5% 1/4W F
D668	8-719-063-73	DIODE D1NL20U-TR		<TRANSFORMER>			
D669	8-719-110-67	DIODE RD27ESB2		T601	△1-435-155-11	TRANSFORMER, LINE FILTER	
D690	8-719-988-30	DIODE D30SC4M		T602	1-435-154-11	TRANSFORMER, FERRITE (PFT)	
<FUSE>				T604	1-435-153-11	TRANSFORMER, CONVERTER (PIT)	
F601	△1-576-231-11	FUSE (H.B.C.) 4A/250V		<VARISTOR>			
<FUSE HOLDER>				VDR602	△1-801-073-31	VARISTOR TNR14V471K660	
FH1	1-533-223-11	CLIP, FUSE		*****			
FH2	1-533-223-11	CLIP, FUSE		* A-1372-675-A	HA MOUNT (D9H5)		
<IC>				*****			
IC603	8-749-013-78	IC MCR5102		<CAPACITOR>			
IC666	8-749-015-89	IC MZ1530		C220	1-163-031-11	CERAMIC CHIP 0.01μF 50V	
IC690	8-749-920-44	IC SE-012N		C221	1-163-031-11	CERAMIC CHIP 0.01μF 50V	
<COIL>				C222	1-163-031-11	CERAMIC CHIP 0.01μF 50V	
L601	1-406-977-21	INDUCTOR 100μH		C223	1-163-031-11	CERAMIC CHIP 0.01μF 50V	
L690	1-469-563-11	INDUCTOR 5.6μH		C224	1-163-031-11	CERAMIC CHIP 0.01μF 50V	
<PHOTO COUPLER>				C225	1-163-031-11	CERAMIC CHIP 0.01μF 50V	
PH601	8-749-010-64	PHOTO COUPLER PC123F2		C226	1-163-031-11	CERAMIC CHIP 0.01μF 50V	
<RESISTOR>				C227	1-163-031-11	CERAMIC CHIP 0.01μF 50V	
R601	△1-220-825-11	CARBON 330K 5%		1/2W	C228	1-163-031-11 CERAMIC CHIP 0.01μF 50V	
R604	1-215-424-00	METAL 1.3K 1%		1/4W	C229	1-163-031-11 CERAMIC CHIP 0.01μF 50V	
R605	1-202-933-61	FUSIBLE 0.1 10%		1/2W	C230	1-163-031-11 CERAMIC CHIP 0.01μF 50V	
R608	1-216-346-00	METAL OXIDE 0.56 5%		1W F	C231	1-126-206-11 ELECT CHIP 100μF 20% 6.3V	
R610	1-216-675-91	METAL CHIP 10K 0.50%		1/10W	C232	1-126-206-11 ELECT CHIP 100μF 20% 6.3V	
R615	1-249-413-11	CARBON 470 5%		1/4W	C233	1-126-206-11 ELECT CHIP 100μF 20% 6.3V	
R621	△1-202-727-00	SOLID 4.7M 20%		1/2W	C234	1-163-031-11 CERAMIC CHIP 0.01μF 50V	
R622	△1-202-727-00	SOLID 4.7M 20%		1/2W	<CONNECTOR>		
R644	1-215-485-00	METAL 470K 1%		1/4W	CN201	1-785-728-21 PIN (PC BOARD), CONNECTOR 7P	
R645	1-215-481-91	METAL 330K 1%		1/4W	CN202	* 1-770-470-21 PIN, CONNECTOR (PC BOARD) 6P	
<DIODE>				CN203	1-779-993-11 PIN, CONNECTOR (PWB) 5P		
D201	8-719-073-01	DIODE MA111-(K8).S0		<DIODE>			
D202	8-719-073-01	DIODE MA111-(K8).S0		*****			



Ref.No.	Part No.	Description	Remark	Ref.No.	Part No.	Description	Remark
C1205	1-163-031-11	CERAMIC CHIP 0.01μF	50V	C60	1-163-031-11	CERAMIC CHIP 0.01μF	50V
C1206	1-163-031-11	CERAMIC CHIP 0.01μF	50V	C61	1-163-031-11	CERAMIC CHIP 0.01μF	50V
C1207	1-163-031-11	CERAMIC CHIP 0.01μF	50V	C62	1-163-031-11	CERAMIC CHIP 0.01μF	50V
<CONNECTOR>				C63	1-163-031-11	CERAMIC CHIP 0.01μF	50V
CN1200	* 1-564-719-11	PIN, CONNECTOR (SMALL TYPE) 3P		C64	1-163-031-11	CERAMIC CHIP 0.01μF	50V
CN1201	* 1-564-726-11	PIN, CONNECTOR (SMALL TYPE) 10P		C65	1-163-031-11	CERAMIC CHIP 0.01μF	50V
CN1203	1-564-721-11	PIN, CONNECTOR (SMALL TYPE) 5P		C67	1-163-031-11	CERAMIC CHIP 0.01μF	50V
<DIODE>				C68	1-163-031-11	CERAMIC CHIP 0.01μF	50V
D1200	8-719-158-19	DIODE RD6.2SB		C81	1-126-206-11	ELECT CHIP 100μF	20% 6.3V
D1201	8-719-073-01	DIODE MA111-(K8),S0		C82	1-124-635-00	ELECT 220μF	20% 6.3V
D1202	8-719-073-01	DIODE MA111-(K8),S0		C83	1-126-206-11	ELECT CHIP 100μF	20% 6.3V
D1203	8-719-073-01	DIODE MA111-(K8),S0		C84	1-126-206-11	ELECT CHIP 100μF	20% 6.3V
D1204	8-719-073-01	DIODE MA111-(K8),S0		C85	1-126-206-11	ELECT CHIP 100μF	20% 6.3V
<CHIP CONDUCTOR>				C86	1-126-206-11	ELECT CHIP 100μF	20% 6.3V
JR1200	1-216-295-91	SHORT	0	C87	1-126-206-11	ELECT CHIP 100μF	20% 6.3V
<RESISTOR>				C89	1-126-206-11	ELECT CHIP 100μF	20% 6.3V
R1200	1-216-081-00	RES,CHIP	22K 5% 1/10W	<CONNECTOR>			
R1201	1-216-065-91	RES,CHIP	4.7K 5% 1/10W	CN2	* 1-564-711-11	PIN, CONNECTOR (SMALL TYPE) 9P	
R1202	1-216-065-91	RES,CHIP	4.7K 5% 1/10W	CN3	* 1-564-712-11	PIN, CONNECTOR (SMALL TYPE) 10P	
R1203	1-216-065-91	RES,CHIP	4.7K 5% 1/10W	CN4	* 1-564-708-11	PIN, CONNECTOR (SMALL TYPE) 6P	
R1204	1-216-065-91	RES,CHIP	4.7K 5% 1/10W	CN5	* 1-564-708-11	PIN, CONNECTOR (SMALL TYPE) 6P	
R1205	1-216-065-91	RES,CHIP	4.7K 5% 1/10W	CN6	* 1-564-508-11	PLUG, CONNECTOR 5P	
R1206	1-216-065-91	RES,CHIP	4.7K 5% 1/10W	<DIODE>			
R1207	1-216-065-91	RES,CHIP	4.7K 5% 1/10W	D1	8-719-158-19	DIODE RD6.2SB	
R1208	1-216-065-91	RES,CHIP	4.7K 5% 1/10W	D2	8-719-158-19	DIODE RD6.2SB	
<VARIABLE RESISTOR>				D3	8-719-158-19	DIODE RD6.2SB	
RV1200	1-223-504-21	RES, VAR, CARBON 20K		D4	8-719-158-19	DIODE RD6.2SB	
<SWITCH>				D5	8-719-158-19	DIODE RD6.2SB	
S1200	1-418-651-11	ENCODER, ROTARY (PHASE)		D6	8-719-158-19	DIODE RD6.2SB	
S1201	1-418-651-11	ENCODER, ROTARY (CHROMA)		D7	8-719-158-19	DIODE RD6.2SB	
S1202	1-418-651-11	ENCODER, ROTARY (BRIGHT)		D8	8-719-158-19	DIODE RD6.2SB	
S1203	1-418-651-11	ENCODER, ROTARY (CONTRAST)SW		<FILTER>			
*****				FL1	1-239-183-11	FILTER, EMI	
* A-1375-186-A	HC COMPL (D9H5)	*****		FL2	1-239-183-11	FILTER, EMI	
1-540-044-11	SOCKET, IC			FL3	1-239-183-11	FILTER, EMI	
4-382-854-01	SCREW(M3X8), P, SW (+)			FL4	1-239-183-11	FILTER, EMI	
<CAPACITOR>				FL5	1-236-071-11	ENCAPSULATED COMPONENT	
C1	1-163-227-11	CERAMIC CHIP 10PF	0.5PF 50V	FL6	1-236-071-11	ENCAPSULATED COMPONENT	
C2	1-163-227-11	CERAMIC CHIP 10PF	0.5PF 50V	FL7	1-239-183-11	FILTER, EMI	
C4	1-163-031-11	CERAMIC CHIP 0.01μF	50V	FL8	1-239-183-11	FILTER, EMI	
C50	1-163-031-11	CERAMIC CHIP 0.01μF	50V	FL9	1-239-183-11	FILTER, EMI	
C52	1-163-031-11	CERAMIC CHIP 0.01μF	50V	FL10	1-239-183-11	FILTER, EMI	
C53	1-163-031-11	CERAMIC CHIP 0.01μF	50V	FL11	1-236-071-11	ENCAPSULATED COMPONENT	
C54	1-163-031-11	CERAMIC CHIP 0.01μF	50V	FL12	1-239-183-11	FILTER, EMI	
C55	1-163-031-11	CERAMIC CHIP 0.01μF	50V	FL13	1-239-183-11	FILTER, EMI	
C56	1-126-941-11	ELECT 470μF	20% 25V	FL14	1-239-183-11	FILTER, EMI	
C57	1-126-786-11	ELECT 47μF	20% 16V	FL15	1-239-183-11	FILTER, EMI	
<IC>				FL16	1-236-071-11	ENCAPSULATED COMPONENT	
IC2	8-759-991-19	IC PST529CMT		<IC>			
IC3	8-759-186-47	IC TC74VHC138F		IC2	8-759-991-19	IC PST529CMT	
IC9	8-759-186-30	IC TC74VHC14F		IC3	8-759-186-47	IC TC74VHC138F	
IC10	8-759-186-30	IC TC74VHC14F		IC9	8-759-186-30	IC TC74VHC14F	
IC11	8-759-175-27	IC TC74VHC574F		IC10	8-759-186-30	IC TC74VHC14F	
IC12	8-759-174-16	IC TC74VHC244F		IC11	8-759-175-27	IC TC74VHC574F	
IC13	8-759-289-43	IC LTC490CS8		IC12	8-759-174-16	IC TC74VHC244F	
IC14	8-759-394-36	IC BA09T		IC13	8-759-289-43	IC LTC490CS8	
				IC14	8-759-394-36	IC BA09T	

Ref.No.	Part No.	Description	Remark	Ref.No.	Part No.	Description	Remark
	<COIL>				<CRYSTAL>		
L2	1-412-537-31	INDUCTOR	100μH	X1	1-767-892-21	VIBRATOR, CRYSTAL (20 MHz)	
L4	1-412-544-15	INDUCTOR	390μH				
	<RESISTOR>				*****		
R1	1-216-073-00	RES,CHIP	10K	5%	1/10W	* A-1372-677-A	HD MOUNT (D9H5)
R2	1-216-295-91	SHORT	0			*****	
R3	1-216-073-00	RES,CHIP	10K	5%	1/10W		
R4	1-216-073-00	RES,CHIP	10K	5%	1/10W		
R5	1-216-073-00	RES,CHIP	10K	5%	1/10W		
	<CAPACITOR>				<CAPACITOR>		
R6	1-216-073-00	RES,CHIP	10K	5%	1/10W	C3200	1-126-791-11 ELECT 10μF 20% 16V
R7	1-216-097-91	RES,CHIP	100K	5%	1/10W	C3201	1-126-791-11 ELECT 10μF 20% 16V
R12	1-216-073-00	RES,CHIP	10K	5%	1/10W	C3202	1-126-791-11 ELECT 10μF 20% 16V
R13	1-216-073-00	RES,CHIP	10K	5%	1/10W	C3203	1-163-031-11 CERAMIC CHIP 0.01μF 50V
R14	1-216-049-91	RES,CHIP	1K	5%	1/10W	C3204	1-126-786-11 ELECT 47μF 20% 16V
R15	1-216-049-91	RES,CHIP	1K	5%	1/10W	C3205	1-163-031-11 CERAMIC CHIP 0.01μF 50V
R16	1-216-073-00	RES,CHIP	10K	5%	1/10W	C3206	1-163-031-11 CERAMIC CHIP 0.01μF 50V
R19	1-216-073-00	RES,CHIP	10K	5%	1/10W	C3207	1-126-786-11 ELECT 47μF 20% 16V
R20	1-216-073-00	RES,CHIP	10K	5%	1/10W	C3209	1-126-791-11 ELECT 10μF 20% 16V
R21	1-216-049-91	RES,CHIP	1K	5%	1/10W	C3210	1-115-868-11 ELECT 0.22μF 20% 50V
R22	1-216-049-91	RES,CHIP	1K	5%	1/10W	C3211	1-163-017-00 CERAMIC CHIP 0.0047μF 10% 50V
R23	1-216-049-91	RES,CHIP	1K	5%	1/10W	C3212	1-126-791-11 ELECT 10μF 20% 16V
R24	1-216-049-91	RES,CHIP	1K	5%	1/10W	C3213	1-126-791-11 ELECT 10μF 20% 16V
R25	1-216-049-91	RES,CHIP	1K	5%	1/10W	C3214	1-137-397-11 MYLAR 0.047μF 5% 100V
R26	1-216-049-91	RES,CHIP	1K	5%	1/10W	C3215	1-128-499-11 ELECT 220μF 20% 16V
R27	1-216-049-91	RES,CHIP	1K	5%	1/10W	C3216	1-126-786-11 ELECT 47μF 20% 16V
R28	1-216-049-91	RES,CHIP	1K	5%	1/10W	C3217	1-128-499-11 ELECT 220μF 20% 16V
R41	1-216-073-00	RES,CHIP	10K	5%	1/10W	C3218	1-126-791-11 ELECT 10μF 20% 16V
R42	1-216-073-00	RES,CHIP	10K	5%	1/10W	C3219	1-163-031-11 CERAMIC CHIP 0.01μF 50V
R43	1-216-073-00	RES,CHIP	10K	5%	1/10W		
R44	1-216-073-00	RES,CHIP	10K	5%	1/10W		
R60	1-216-089-91	RES,CHIP	47K	5%	1/10W		
R61	1-216-089-91	RES,CHIP	47K	5%	1/10W		
R62	1-216-089-91	RES,CHIP	47K	5%	1/10W		
R63	1-216-089-91	RES,CHIP	47K	5%	1/10W		
R64	1-216-089-91	RES,CHIP	47K	5%	1/10W		
R65	1-216-089-91	RES,CHIP	47K	5%	1/10W		
R66	1-216-089-91	RES,CHIP	47K	5%	1/10W		
R67	1-216-089-91	RES,CHIP	47K	5%	1/10W		
R68	1-216-097-91	RES,CHIP	100K	5%	1/10W		
R70	1-216-097-91	RES,CHIP	100K	5%	1/10W		
R71	1-216-097-91	RES,CHIP	100K	5%	1/10W		
R72	1-216-097-91	RES,CHIP	100K	5%	1/10W		
R73	1-216-097-91	RES,CHIP	100K	5%	1/10W		
R74	1-216-097-91	RES,CHIP	100K	5%	1/10W		
R75	1-216-097-91	RES,CHIP	100K	5%	1/10W		
R76	1-216-097-91	RES,CHIP	100K	5%	1/10W		
R77	1-216-097-91	RES,CHIP	100K	5%	1/10W		
R78	1-216-097-91	RES,CHIP	100K	5%	1/10W		
R79	1-216-097-91	RES,CHIP	100K	5%	1/10W		
R80	1-216-097-91	RES,CHIP	100K	5%	1/10W		
R81	1-216-097-91	RES,CHIP	100K	5%	1/10W		
R82	1-216-097-91	RES,CHIP	100K	5%	1/10W		
R83	1-216-097-91	RES,CHIP	100K	5%	1/10W		
R84	1-216-097-91	RES,CHIP	100K	5%	1/10W		
R85	1-216-097-91	RES,CHIP	100K	5%	1/10W		
R86	1-216-097-91	RES,CHIP	100K	5%	1/10W		
R87	1-216-097-91	RES,CHIP	100K	5%	1/10W		
R88	1-216-097-91	RES,CHIP	100K	5%	1/10W		
R89	1-216-097-91	RES,CHIP	100K	5%	1/10W		
R90	1-216-097-91	RES,CHIP	100K	5%	1/10W		
R91	1-216-097-91	RES,CHIP	100K	5%	1/10W		
R92	1-216-097-91	RES,CHIP	100K	5%	1/10W		
R93	1-216-097-91	RES,CHIP	100K	5%	1/10W		
R94	1-216-097-91	RES,CHIP	100K	5%	1/10W		
	<CONNECTOR>				<CONNECTOR>		
				CN3200	* 1-564-518-11	PLUG, CONNECTOR 3P	
				CN3202	* 1-564-517-11	PLUG, CONNECTOR 2P	
				CN3203	* 1-564-526-11	PLUG, CONNECTOR 11P	
	<FERRITE BEAD>				<FERRITE BEAD>		
				FB3200	1-410-396-41	FERRITE	0.45μH
	<FILTER>				<FILTER>		
				FL3200	1-239-384-11	FILTER, EMI	
				FL3201	1-239-384-11	FILTER, EMI	
				FL3202	1-239-384-11	FILTER, EMI	
	<IC>				<IC>		
				IC3200	8-759-009-06	IC MC14052BF	
				IC3201	8-759-420-04	IC AN5265	
	<JACK>				<JACK>		
				J3200	1-793-632-11	JACK, PIN (LINE A)	
				J3201	1-793-632-11	JACK, PIN (LINE B)	
				J3202	1-793-632-11	JACK, PIN (LINE C)	
	<JACKCHIP CONDUCTOR>				<JACKCHIP CONDUCTOR>		
				JR3201	1-216-295-91	SHORT	0
	<TRANSISTOR>				<TRANSISTOR>		
				Q3200	8-729-026-50	TRANSISTOR 2SA1037AK-T146-QR	
				Q3201	8-729-026-50	TRANSISTOR 2SA1037AK-T146-QR	

Ref.No.	Part No.	Description	Remark	Ref.No.	Part No.	Description	Remark
Q3202	8-729-026-50	TRANSISTOR 2SA1037AK-T146-QR		C110	1-163-031-11	CERAMIC CHIP 0.01μF	50V
Q3203	8-729-120-28	TRANSISTOR 2SC1623-L5L6		C111	1-126-392-11	ELECT CHIP 100μF	20% 6.3V
Q3205	1-801-806-11	TRANSISTOR DTC144EKA-T146		C112	1-126-392-11	ELECT CHIP 100μF	20% 6.3V
Q3206	1-801-806-11	TRANSISTOR DTC144EKA-T146		C113	1-163-031-11	CERAMIC CHIP 0.01μF	50V
Q3207	8-729-026-49	TRANSISTOR 2SA1037AK-T146-R		C114	1-163-031-11	CERAMIC CHIP 0.01μF	50V
				C115	1-163-031-11	CERAMIC CHIP 0.01μF	50V
		<RESISTOR>		C116	1-126-392-11	ELECT CHIP 100μF	20% 6.3V
R3200	1-249-440-11	CARBON 82K	5% 1/4W	C117	1-163-031-11	CERAMIC CHIP 0.01μF	50V
R3201	1-249-440-11	CARBON 82K	5% 1/4W	C118	1-126-392-11	ELECT CHIP 100μF	20% 6.3V
R3202	1-249-440-11	CARBON 82K	5% 1/4W	C119	1-163-031-11	CERAMIC CHIP 0.01μF	50V
R3203	1-216-097-91	RES,CHIP 100K	5% 1/10W	C120	1-163-031-11	CERAMIC CHIP 0.01μF	50V
R3204	1-216-097-91	RES,CHIP 100K	5% 1/10W	C121	1-126-392-11	ELECT CHIP 100μF	20% 6.3V
R3205	1-216-097-91	RES,CHIP 100K	5% 1/10W	C122	1-126-392-11	ELECT CHIP 100μF	20% 6.3V
R3206	1-216-105-91	RES,CHIP 220K	5% 1/10W	C123	1-163-031-11	CERAMIC CHIP 0.01μF	50V
R3207	1-216-115-00	RES,CHIP 560K	5% 1/10W	C124	1-163-031-11	CERAMIC CHIP 0.01μF	50V
R3208	1-216-105-91	RES,CHIP 220K	5% 1/10W	C125	1-126-392-11	ELECT CHIP 100μF	20% 6.3V
R3209	1-216-115-00	RES,CHIP 560K	5% 1/10W	C126	1-163-031-11	CERAMIC CHIP 0.01μF	50V
R3210	1-216-105-91	RES,CHIP 220K	5% 1/10W	C127	1-163-031-11	CERAMIC CHIP 0.01μF	50V
R3211	1-216-115-00	RES,CHIP 560K	5% 1/10W	C128	1-126-392-11	ELECT CHIP 100μF	20% 6.3V
R3212	1-216-077-91	RES,CHIP 15K	5% 1/10W	C129	1-126-392-11	ELECT CHIP 100μF	20% 6.3V
R3213	1-216-077-91	RES,CHIP 15K	5% 1/10W	C130	1-163-031-11	CERAMIC CHIP 0.01μF	50V
R3214	1-216-077-91	RES,CHIP 15K	5% 1/10W	C131	1-163-031-11	CERAMIC CHIP 0.01μF	50V
R3215	1-216-025-91	RES,CHIP 100	5% 1/10W	C132	1-126-392-11	ELECT CHIP 100μF	20% 6.3V
R3216	1-216-025-91	RES,CHIP 100	5% 1/10W	C133	1-126-392-11	ELECT CHIP 100μF	20% 6.3V
R3217	1-216-025-91	RES,CHIP 100	5% 1/10W	C134	1-163-031-11	CERAMIC CHIP 0.01μF	50V
R3218	1-216-025-91	RES,CHIP 100	5% 1/10W	C135	1-163-031-11	CERAMIC CHIP 0.01μF	50V
R3219	1-216-025-91	RES,CHIP 100	5% 1/10W	C136	1-126-392-11	ELECT CHIP 100μF	20% 6.3V
R3220	1-216-025-91	RES,CHIP 100	5% 1/10W	C137	1-163-031-11	CERAMIC CHIP 0.01μF	50V
R3221	1-216-077-91	RES,CHIP 15K	5% 1/10W	C139	1-163-031-11	CERAMIC CHIP 0.01μF	50V
R3222	1-216-025-91	RES,CHIP 100	5% 1/10W	C140	1-163-031-11	CERAMIC CHIP 0.01μF	50V
R3226	1-216-091-00	RES,CHIP 56K	5% 1/10W	C141	1-163-031-11	CERAMIC CHIP 0.01μF	50V
R3228	1-249-389-11	CARBON 4.7	5% 1/4W	C142	1-163-031-11	CERAMIC CHIP 0.01μF	50V
R3229	1-249-424-11	CARBON 3.9K	5% 1/4W	C144	1-163-031-11	CERAMIC CHIP 0.01μF	50V
R3230	1-249-415-11	CARBON 680	5% 1/4W	C145	1-163-031-11	CERAMIC CHIP 0.01μF	50V
R3231	1-216-085-00	RES,CHIP 33K	5% 1/10W	C147	1-163-031-11	CERAMIC CHIP 0.01μF	50V
R3232	1-216-081-00	RES,CHIP 22K	5% 1/10W	C148	1-163-031-11	CERAMIC CHIP 0.01μF	50V
R3233	1-249-393-11	CARBON 10	5% 1/4W F	C149	1-126-392-11	ELECT CHIP 100μF	20% 6.3V
R3234	1-249-389-11	CARBON 4.7	5% 1/4W F	C150	1-163-031-11	CERAMIC CHIP 0.01μF	50V
R3235	1-216-073-00	RES,CHIP 10K	5% 1/10W	C151	1-163-031-11	CERAMIC CHIP 0.01μF	50V
R3236	1-216-073-00	RES,CHIP 10K	5% 1/10W	C153	1-163-031-11	CERAMIC CHIP 0.01μF	50V
R3237	1-216-081-00	RES,CHIP 22K	5% 1/10W	C154	1-163-031-11	CERAMIC CHIP 0.01μF	50V
R3238	1-216-077-91	RES,CHIP 15K	5% 1/10W	C159	1-126-392-11	ELECT CHIP 100μF	20% 6.3V
R3239	1-216-025-91	RES,CHIP 100	5% 1/10W	C160	1-163-031-11	CERAMIC CHIP 0.01μF	50V
				C161	1-163-031-11	CERAMIC CHIP 0.01μF	50V
				C162	1-163-031-11	CERAMIC CHIP 0.01μF	50V
				C163	1-126-392-11	ELECT CHIP 100μF	20% 6.3V
				C164	1-163-031-11	CERAMIC CHIP 0.01μF	50V
*****							
	* A-1306-574-A	MA COMPL (D9H1)		C165	1-126-400-11	ELECT CHIP 22μF	20% 35V
		*****		C166	1-126-392-11	ELECT CHIP 100μF	20% 6.3V
	* A-1306-581-A	MA COMPL (D9H5)		C168	1-126-392-11	ELECT CHIP 100μF	20% 6.3V
		*****		C169	1-163-031-11	CERAMIC CHIP 0.01μF	50V
				C171	1-163-031-11	CERAMIC CHIP 0.01μF	50V
	1-540-222-11	SOCKET, IC (PCC PACKAGE) 84P		C172	1-126-392-11	ELECT CHIP 100μF	20% 6.3V
	1-550-104-11	HOLDER, BATTERY					
		BATTERY, LITHIUM CR2025					
		<CAPACITOR>					
C101	1-163-031-11	CERAMIC CHIP 0.01μF	50V				
C102	1-126-392-11	ELECT CHIP 100μF	20% 6.3V				
C103	1-126-392-11	ELECT CHIP 100μF	20% 6.3V				
C104	1-163-031-11	CERAMIC CHIP 0.01μF	50V				
C105	1-163-235-11	CERAMIC CHIP 22PF	5% 50V				
C106	1-163-227-11	CERAMIC CHIP 10PF	0.5PF 50V				
C108	1-126-392-11	ELECT CHIP 100μF	20% 6.3V				
C109	1-126-392-11	ELECT CHIP 100μF	20% 6.3V				
		<CONNECTOR>					
				CN101	* 1-564-525-11	PLUG, CONNECTOR 10P	
				CN102	* 1-793-722-11	PIN, CONNECTOR (PC BOARD) 50P	
				CN103	* 1-564-522-11	PLUG, CONNECTOR 7P	
				CN104	* 1-564-526-11	PLUG, CONNECTOR 11P (D9H5)	
				CN105	* 1-564-524-11	PLUG, CONNECTOR 9P (D9H5)	
		<DIODE>					
				D101	8-719-158-19	DIODE RD6.2SB	
				D102	8-719-158-19	DIODE RD6.2SB	



Ref.No.	Part No.	Description	Remark	Ref.No.	Part No.	Description	Remark
D103	8-719-158-19	DIODE RD6.2SB		R106	1-216-097-91	RES,CHIP 100K 5%	1/10W
D104	8-719-158-19	DIODE RD6.2SB		R107	1-216-097-91	RES,CHIP 100K 5%	1/10W
D105	8-719-158-19	DIODE RD6.2SB (D9H5)		R108	1-216-097-91	RES,CHIP 100K 5%	1/10W
D107	8-719-158-19	DIODE RD6.2SB (D9H5)		R109	1-216-097-91	RES,CHIP 100K 5%	1/10W
D109	8-719-158-19	DIODE RD6.2SB		R110	1-216-097-91	RES,CHIP 100K 5%	1/10W
		<FILTER>		R111	1-216-097-91	RES,CHIP 100K 5%	1/10W
FL103	1-239-183-11	FILTER, EMI		R112	1-216-097-91	RES,CHIP 100K 5%	1/10W
FL104	1-239-183-11	FILTER, EMI		R113	1-216-025-91	RES,CHIP 100 5%	1/10W
FL105	1-239-183-11	FILTER, EMI		R114	1-216-295-91	SHORT 0 (D9H5)	
FL107	1-239-183-11	FILTER, EMI		R115	1-216-025-91	RES,CHIP 100 5%	1/10W
FL108	1-239-183-11	FILTER, EMI		R116	1-216-025-91	RES,CHIP 100 5%	1/10W
FL109	1-239-183-11	FILTER, EMI		R117	1-216-025-91	RES,CHIP 100 5%	1/10W
FL110	1-239-183-11	FILTER, EMI		R118	1-216-097-91	RES,CHIP 100K 5%	1/10W
FL111	1-239-183-11	FILTER, EMI		R119	1-216-097-91	RES,CHIP 100K 5%	1/10W
FL112	1-239-183-11	FILTER, EMI		R120	1-216-025-91	RES,CHIP 100 5%	1/10W
FL113	1-239-183-11	FILTER, EMI		R121	1-216-097-91	RES,CHIP 100K 5%	1/10W
FL114	1-236-071-11	ENCAPSULATED COMPONENT		R122	1-216-025-91	RES,CHIP 100 5%	1/10W
FL115	1-236-071-11	ENCAPSULATED COMPONENT		R123	1-216-121-91	RES,CHIP 1M 5%	1/10W
FL116	1-239-183-11	FILTER, EMI (D9H5)		R124	1-216-025-91	RES,CHIP 100 5%	1/10W
FL117	1-236-071-11	ENCAPSULATED COMPONENT		R125	1-216-065-91	RES,CHIP 4.7K 5%	1/10W
FL118	1-239-183-11	FILTER, EMI (D9H5)		R126	1-216-025-91	RES,CHIP 100 5%	1/10W
FL120	1-239-183-11	FILTER, EMI		R127	1-216-065-91	RES,CHIP 4.7K 5%	1/10W
FL121	1-239-183-11	FILTER, EMI (D9H5)		R128	1-216-097-91	RES,CHIP 100K 5%	1/10W
FL123	1-239-183-11	FILTER, EMI		R129	1-216-097-91	RES,CHIP 100K 5%	1/10W
		<IC>		R130	1-216-049-91	RES,CHIP 1K 5%	1/10W
IC101	8-759-186-44	IC TC74VHC125F		R131	1-216-049-91	RES,CHIP 1K 5%	1/10W
IC102	8-759-082-59	IC TC7W32FU		R132	1-216-097-91	RES,CHIP 100K 5%	1/10W
IC103	8-759-925-75	IC SN74HC05ANS		R133	1-216-049-91	RES,CHIP 1K 5%	1/10W
IC104	8-759-239-98	IC TC74HC30AF		R134	1-216-049-91	RES,CHIP 1K 5%	1/10W
IC106	8-759-644-13	IC HD6435368AX06M		R135	1-216-073-00	RES,CHIP 10K 5%	1/10W
IC107	8-759-081-44	IC TC74VHC04F		R136	1-216-073-00	RES,CHIP 10K 5%	1/10W
IC108	8-759-553-93	IC MBM29F400BC-90PF		R137	1-216-073-00	RES,CHIP 10K 5%	1/10W
IC109	8-759-186-47	IC TC74VHC138F		R138	1-216-097-91	RES,CHIP 100K 5%	1/10W
IC110	8-759-346-07	IC MM1026BFB		R139	1-216-049-91	RES,CHIP 1K 5%	1/10W
IC111	8-759-497-29	IC LC35256DM-70-TLM		R140	1-216-097-91	RES,CHIP 100K 5%	1/10W
IC113	8-759-575-91	IC MAX490ECSA		R141	1-216-049-91	RES,CHIP 1K 5%	1/10W
		<CHIP CONDUCTOR>		R142	1-216-097-91	RES,CHIP 100K 5%	1/10W
JR101	1-216-295-91	SHORT 0		R143	1-216-049-91	RES,CHIP 1K 5%	1/10W
JR103	1-216-097-91	RES,CHIP 100K 5%	1/10W	R144	1-216-097-91	RES,CHIP 100K 5%	1/10W
		<COIL>		R145	1-216-049-91	RES,CHIP 1K 5%	1/10W
L101	1-412-537-31	INDUCTOR 100μH		R146	1-216-097-91	RES,CHIP 100K 5%	1/10W
		<TRANSISTOR>		R147	1-216-049-91	RES,CHIP 1K 5%	1/10W
Q102	8-729-027-38	TRANSISTOR DTA144EKA-T146		R148	1-216-097-91	RES,CHIP 100K 5%	1/10W
Q103	1-801-806-11	TRANSISTOR DTC144EKA-T146		R150	1-216-097-91	RES,CHIP 100K 5%	1/10W
Q104	1-801-806-11	TRANSISTOR DTC144EKA-T146		R151	1-216-097-91	RES,CHIP 100K 5%	1/10W
Q105	8-729-903-46	TRANSISTOR 2SB1132-P		R152	1-216-073-00	RES,CHIP 10K 5%	1/10W
Q106	8-729-903-46	TRANSISTOR 2SB1132-P		R153	1-216-073-00	RES,CHIP 10K 5%	1/10W
		<RESISTOR>		R154	1-216-097-91	RES,CHIP 100K 5%	1/10W
R101	1-216-097-91	RES,CHIP 100K 5%	1/10W	R155	1-216-097-91	RES,CHIP 100K 5%	1/10W
R102	1-216-097-91	RES,CHIP 100K 5%	1/10W	R156	1-216-097-91	RES,CHIP 100K 5%	1/10W
R103	1-216-025-91	RES,CHIP 100 5%	1/10W	R157	1-216-097-91	RES,CHIP 100K 5%	1/10W
R104	1-216-025-91	RES,CHIP 100 5%	1/10W	R158	1-216-073-00	RES,CHIP 10K 5%	1/10W
R105	1-216-097-91	RES,CHIP 100K 5%	1/10W	R159	1-216-049-91	RES,CHIP 1K 5%	1/10W
				R160	1-216-073-00	RES,CHIP 10K 5%	1/10W
				R161	1-216-097-91	RES,CHIP 100K 5%	1/10W
				R162	1-216-097-91	RES,CHIP 100K 5%	1/10W
				R163	1-216-097-91	RES,CHIP 100K 5%	1/10W
				R164	1-216-097-91	RES,CHIP 100K 5%	1/10W
				R165	1-216-097-91	RES,CHIP 100K 5%	1/10W
				R166	1-216-025-91	RES,CHIP 100 5%	1/10W
				R167	1-216-097-91	RES,CHIP 100K 5%	1/10W
				R168	1-216-025-91	RES,CHIP 100 5%	1/10W
				R169	1-216-097-91	RES,CHIP 100K 5%	1/10W
				R170	1-216-025-91	RES,CHIP 100 5%	1/10W
				R171	1-216-025-91	RES,CHIP 100 5%	1/10W



Ref.No.	Part No.	Description	Remark	Ref.No.	Part No.	Description	Remark
R173	1-216-025-91	RES,CHIP	100 5% 1/10W	C1115	1-126-206-11	ELECT CHIP 100μF 20%	6.3V
R174	1-216-025-91	RES,CHIP	100 5% 1/10W	C1116	1-163-031-11	CERAMIC CHIP 0.01μF	50V
R177	1-216-025-91	RES,CHIP	100 5% 1/10W	C1117	1-126-206-11	ELECT CHIP 100μF 20%	6.3V
R178	1-216-053-00	RES,CHIP	1.5K 5% 1/10W	C1118	1-163-021-91	CERAMIC CHIP 0.01μF	10% 50V
R179	1-216-047-91	RES,CHIP	820 5% 1/10W	C1119	1-107-682-11	CERAMIC CHIP 1μF	10% 16V
R180	1-216-073-00	RES,CHIP	10K 5% 1/10W	C1120	1-163-031-11	CERAMIC CHIP 0.01μF	50V
R181	1-216-025-91	RES,CHIP	100 5% 1/10W	C1121	1-126-206-11	ELECT CHIP 100μF 20%	6.3V
R182	1-216-025-91	RES,CHIP	100 5% 1/10W	C1122	1-165-319-11	CERAMIC CHIP 0.1μF	50V
R183	1-216-073-00	RES,CHIP	10K 5% 1/10W	C1123	1-163-031-11	CERAMIC CHIP 0.01μF	50V
R184	1-216-025-91	RES,CHIP	100 5% 1/10W	C1124	1-165-319-11	CERAMIC CHIP 0.1μF	50V
R185	1-216-025-91	RES,CHIP	100 5% 1/10W	C1125	1-126-206-11	ELECT CHIP 100μF 20%	6.3V
R186	1-216-025-91	RES,CHIP	100 5% 1/10W	C1126	1-165-319-11	CERAMIC CHIP 0.1μF	50V
R187	1-216-025-91	RES,CHIP	100 5% 1/10W	C1127	1-126-206-11	ELECT CHIP 100μF 20%	6.3V
R188	1-216-025-91	RES,CHIP	100 5% 1/10W	C1128	1-165-319-11	CERAMIC CHIP 0.1μF	50V
R189	1-216-025-91	RES,CHIP	100 5% 1/10W	C1129	1-126-206-11	ELECT CHIP 100μF 20%	6.3V
R190	1-216-053-00	RES,CHIP	1.5K 5% 1/10W	C1130	1-126-206-11	ELECT CHIP 100μF 20%	6.3V
R191	1-216-053-00	RES,CHIP	1.5K 5% 1/10W	C1131	1-163-031-11	CERAMIC CHIP 0.01μF	50V
R192	1-216-097-91	RES,CHIP	100K 5% 1/10W	C1132	1-165-319-11	CERAMIC CHIP 0.1μF	50V
R193	1-216-053-00	RES,CHIP	1.5K 5% 1/10W	C1133	1-165-319-11	CERAMIC CHIP 0.1μF	50V
R194	1-216-053-00	RES,CHIP	1.5K 5% 1/10W	C1134	1-165-319-11	CERAMIC CHIP 0.1μF	50V
R195	1-216-053-00	RES,CHIP	1.5K 5% 1/10W	C1135	1-163-021-91	CERAMIC CHIP 0.01μF	10% 50V
R196	1-216-073-00	RES,CHIP	10K 5% 1/10W	C1136	1-107-682-11	CERAMIC CHIP 1μF	10% 16V
R197	1-216-073-00	RES,CHIP	10K 5% 1/10W	C1137	1-165-319-11	CERAMIC CHIP 0.1μF	50V
R198	1-216-097-91	RES,CHIP	100K 5% 1/10W	C1138	1-165-319-11	CERAMIC CHIP 0.1μF	50V
<THERMISTOR>				C1139	1-165-319-11	CERAMIC CHIP 0.1μF	50V
THP101	1-771-075-21	THERMISTOR, POSITIVE		C1140	1-165-319-11	CERAMIC CHIP 0.1μF	50V
THP102	1-771-075-21	THERMISTOR, POSITIVE		C1141	1-163-031-11	CERAMIC CHIP 0.01μF	50V
<TEST PIN>				C1142	1-126-206-11	ELECT CHIP 100μF 20%	6.3V
TP110	* 1-537-864-11	PIN, POST		C1143	1-163-031-11	CERAMIC CHIP 0.01μF	50V
TP111	* 1-537-864-11	PIN, POST		C1144	1-163-031-11	CERAMIC CHIP 0.01μF	50V
TP112	* 1-537-864-11	PIN, POST		C1145	1-126-206-11	ELECT CHIP 100μF 20%	6.3V
TP113	* 1-537-864-11	PIN, POST		C1146	1-163-031-11	CERAMIC CHIP 0.01μF	50V
TP114	* 1-537-864-11	PIN, POST		C1147	1-163-031-11	CERAMIC CHIP 0.01μF	50V
<CRYSTAL>				C1148	1-163-031-11	CERAMIC CHIP 0.01μF	50V
X101	1-767-892-21	VIBRATOR, CRYSTAL (20 MHz)		C1149	1-163-031-11	CERAMIC CHIP 0.01μF	50V
*****				C1150	1-126-206-11	ELECT CHIP 100μF 20%	6.3V
* A-1306-575-A	MB COMPL (D9H1)	*****		C1151	1-163-031-11	CERAMIC CHIP 0.01μF	50V
* A-1306-576-A	MB COMPL (D9H5)	*****		C1152	1-163-031-11	CERAMIC CHIP 0.01μF	50V
7-432-114-11	SCREW LOCK			C1153	1-163-031-11	CERAMIC CHIP 0.01μF	50V
<CAPACITOR>				C1154	1-163-031-11	CERAMIC CHIP 0.01μF	50V
C1100	1-126-206-11	ELECT CHIP 100μF	20% 6.3V	C1155	1-163-031-11	CERAMIC CHIP 0.01μF	50V
C1101	1-165-319-11	CERAMIC CHIP 0.1μF	50V	C1156	1-126-206-11	ELECT CHIP 100μF 20%	6.3V
C1102	1-126-206-11	ELECT CHIP 100μF	20% 6.3V	C1157	1-163-031-11	CERAMIC CHIP 0.01μF	50V
C1103	1-165-319-11	CERAMIC CHIP 0.1μF	50V	C1158	1-126-206-11	ELECT CHIP 100μF 20%	6.3V
C1104	1-163-031-11	CERAMIC CHIP 0.01μF	50V	C1159	1-163-021-91	CERAMIC CHIP 0.01μF	10% 50V
C1105	1-163-031-11	CERAMIC CHIP 0.01μF	50V	C1160	1-163-021-91	CERAMIC CHIP 0.01μF	10% 50V
C1106	1-126-206-11	ELECT CHIP 100μF	20% 6.3V	C1161	1-163-021-91	CERAMIC CHIP 0.01μF	10% 50V
C1107	1-126-206-11	ELECT CHIP 100μF	20% 6.3V	C1162	1-164-690-91	CERAMIC CHIP 0.0022μF	5% 50V
C1108	1-163-233-11	CERAMIC CHIP 18PF	5% 50V	C1180	1-163-243-11	CERAMIC CHIP 47PF	5% 50V
C1109	1-163-031-11	CERAMIC CHIP 0.01μF	50V	<CONNECTOR>			
C1110	1-163-231-11	CERAMIC CHIP 15PF	5% 50V	CN1100	* 1-564-524-11	PLUG, CONNECTOR 9P	
C1111	1-126-206-11	ELECT CHIP 100μF	20% 6.3V	CN1101	* 1-564-527-11	PLUG, CONNECTOR 12P	
C1112	1-163-031-11	CERAMIC CHIP 0.01μF	50V	CN1102	* 1-793-722-11	PIN, CONNECTOR (PC BOARD) 50P	
C1114	1-163-031-11	CERAMIC CHIP 0.01μF	50V	CN1103	1-695-581-21	CONNECTOR, D SUB	
				CN1104	1-695-581-21	CONNECTOR, D SUB	
				CN1105	* 1-564-524-11	PLUG, CONNECTOR 9P	
				CN1106	* 1-564-522-11	PLUG, CONNECTOR 7P	
				CN1107	1-695-581-21	CONNECTOR, D SUB	
				CN1109	1-793-721-11	JACK, MODULAR	
<DIODE>							
				D1100	8-719-158-19	DIODE RD6.2SB	
				D1101	8-719-158-19	DIODE RD6.2SB	
				D1102	8-719-158-19	DIODE RD6.2SB	

Ref.No.	Part No.	Description	Remark	Ref.No.	Part No.	Description	Remark
D1103	8-719-158-19	DIODE RD6.2SB		R1106	1-216-025-91	RES,CHIP 100 5%	1/10W
D1104	8-719-037-22	DIODE RD12SB-T1		R1107	1-216-025-91	RES,CHIP 100 5%	1/10W
D1105	8-719-037-22	DIODE RD12SB-T1		R1108	1-216-025-91	RES,CHIP 100 5%	1/10W
D1106	8-719-037-22	DIODE RD12SB-T1		R1109	1-216-025-91	RES,CHIP 100 5%	1/10W
D1107	8-719-037-22	DIODE RD12SB-T1		R1110	1-216-025-91	RES,CHIP 100 5%	1/10W
D1108	8-719-037-22	DIODE RD12SB-T1		R1111	1-216-025-91	RES,CHIP 100 5%	1/10W
D1109	8-719-037-22	DIODE RD12SB-T1		R1112	1-216-025-91	RES,CHIP 100 5%	1/10W
D1110	8-719-158-19	DIODE RD6.2SB		R1113	1-216-097-91	RES,CHIP 100K 5%	1/10W
D1111	8-719-158-19	DIODE RD6.2SB		R1114	1-216-025-91	RES,CHIP 100 5%	1/10W
D1112	8-719-158-19	DIODE RD6.2SB		R1115	1-216-025-91	RES,CHIP 100 5%	1/10W
D1113	8-719-158-19K	DIODE RD6.2SB		R1117	1-216-121-91	RES,CHIP 1M 5%	1/10W
D1114	8-719-158-19	DIODE RD6.2SB		R1118	1-216-077-91	RES,CHIP 15K 5%	1/10W
D1115	8-719-158-19	DIODE RD6.2SB		R1119	1-216-025-91	RES,CHIP 100 5%	1/10W
D1116	8-719-158-19	DIODE RD6.2SB		R1120	1-216-097-91	RES,CHIP 100K 5%	1/10W
D1117	8-719-158-19	DIODE RD6.2SB		R1121	1-216-097-91	RES,CHIP 100K 5%	1/10W
D1118	8-719-158-19	DIODE RD6.2SB		R1122	1-216-097-91	RES,CHIP 100K 5%	1/10W
		<FILTER>		R1123	1-216-097-91	RES,CHIP 100K 5%	1/10W
FL1100	1-239-183-11	FILTER, EMI		R1125	1-216-097-91	RES,CHIP 100K 5%	1/10W
FL1101	1-239-183-11	FILTER, EMI		R1126	1-216-097-91	RES,CHIP 100K 5%	1/10W
FL1102	1-239-183-11	FILTER, EMI		R1127	1-216-097-91	RES,CHIP 100K 5%	1/10W
FL1103	1-239-183-11	FILTER, EMI		R1128	1-216-097-91	RES,CHIP 100K 5%	1/10W
FL1108	1-239-183-11	FILTER, EMI		R1130	1-216-089-91	RES,CHIP 47K 5%	1/10W
FL1109	1-239-183-11	FILTER, EMI		R1131	1-216-097-91	RES,CHIP 100K 5%	1/10W
FL1110	1-239-183-11	FILTER, EMI		R1132	1-216-097-91	RES,CHIP 100K 5%	1/10W
FL1111	1-239-183-11	FILTER, EMI		R1133	1-216-089-91	RES,CHIP 47K 5%	1/10W
FL1112	1-239-183-11	FILTER, EMI		R1136	1-216-089-91	RES,CHIP 47K 5%	1/10W
FL1113	1-239-183-11	FILTER, EMI		R1137	1-216-295-91	SHORT 0	
FL1114	1-239-183-11	FILTER, EMI		R1138	1-216-625-11	METAL CHIP 82 0.50%	1/10W
FL1115	1-239-183-11	FILTER, EMI		R1140	1-216-638-11	METAL CHIP 300 0.50%	1/10W
FL1116	1-239-183-11	FILTER, EMI		R1141	1-216-073-00	RES,CHIP 10K 5%	1/10W
FL1117	1-239-183-11	FILTER, EMI		R1142	1-216-073-00	RES,CHIP 10K 5%	1/10W
FL1118	1-239-183-11	FILTER, EMI		R1143	1-216-073-00	RES,CHIP 10K 5%	1/10W
FL1119	1-239-183-11	FILTER, EMI		R1144	1-216-073-00	RES,CHIP 10K 5%	1/10W
FL1120	1-239-183-11	FILTER, EMI		R1145	1-216-089-91	RES,CHIP 47K 5%	1/10W
FL1121	1-239-183-11	FILTER, EMI		R1147	1-216-295-91	SHORT 0	
		<IC>		R1148	1-216-625-11	METAL CHIP 82 0.50%	1/10W
IC1100	8-759-186-26	IC TC74VHC02F		R1149	1-216-638-11	METAL CHIP 300 0.50%	1/10W
IC1101	8-759-186-44	IC TC74VHC125F		R1151	1-216-049-91	RES,CHIP 1K 5%	1/10W
IC1102	8-759-081-44	IC TC74VHC04F		R1152	1-216-049-91	RES,CHIP 1K 5%	1/10W
IC1103	8-759-397-01	IC MAX487CSA-TE2		R1153	1-216-049-91	RES,CHIP 1K 5%	1/10W
IC1104	8-759-186-30	IC TC74VHC14F		R1154	1-216-049-91	RES,CHIP 1K 5%	1/10W
IC1105	8-759-594-45	IC MAX3100CEE-TG068		R1155	1-216-049-91	RES,CHIP 1K 5%	1/10W
IC1106	8-759-397-01	IC MAX487CSA-TE2		R1156	1-216-049-91	RES,CHIP 1K 5%	1/10W
IC1107	8-759-522-14	IC MB90096PF-G-127-BND-ER		R1157	1-216-049-91	RES,CHIP 1K 5%	1/10W
IC1108	8-759-594-45	IC MAX3100CEE-TG068		R1158	1-216-097-91	RES,CHIP 100K 5%	1/10W
IC1109	8-759-252-59	IC MAX202CSE		R1159	1-216-049-91	RES,CHIP 1K 5%	1/10W
IC1110	8-759-594-46	IC MB90096PF-178		R1160	1-216-097-91	RES,CHIP 100K 5%	1/10W
IC1112	8-759-454-11	IC MC74HC589AFEL		R1161	1-216-097-91	RES,CHIP 100K 5%	1/10W
		<COIL>		R1162	1-216-097-91	RES,CHIP 100K 5%	1/10W
L1100	1-412-537-31	INDUCTOR 100μH		R1163	1-216-097-91	RES,CHIP 100K 5%	1/10W
L1101	1-412-537-31	INDUCTOR 100μH		R1164	1-216-097-91	RES,CHIP 100K 5%	1/10W
L1102	1-412-537-31	INDUCTOR 100μH		R1165	1-216-097-91	RES,CHIP 100K 5%	1/10W
		<RESISTOR>		R1166	1-216-097-91	RES,CHIP 100K 5%	1/10W
R1100	1-216-025-91	RES,CHIP 100 5%	1/10W	R1167	1-216-089-91	RES,CHIP 47K 5%	1/10W
R1101	1-216-025-91	RES,CHIP 100 5%	1/10W	R1170	1-216-065-91	RES,CHIP 4.7K 5%	1/10W
R1102	1-216-025-91	RES,CHIP 100 5%	1/10W	R1171	1-216-065-91	RES,CHIP 4.7K 5%	1/10W
R1103	1-216-025-91	RES,CHIP 100 5%	1/10W	R1172	1-216-089-91	RES,CHIP 47K 5%	1/10W
R1104	1-216-025-91	RES,CHIP 100 5%	1/10W	R1173	1-216-089-91	RES,CHIP 47K 5%	1/10W
				R1174	1-216-097-91	RES,CHIP 100K 5%	1/10W
				R1175	1-216-097-91	RES,CHIP 100K 5%	1/10W
				R1176	1-216-097-91	RES,CHIP 100K 5%	1/10W
				R1177	1-216-097-91	RES,CHIP 100K 5%	1/10W
				R1180	1-216-065-91	RES,CHIP 4.7K 5%	1/10W
				R1181	1-216-097-91	RES,CHIP 100K 5%	1/10W
				R1182	1-216-049-91	RES,CHIP 1K 5%	1/10W

Ref.No.	Part No.	Description	Remark	Ref.No.	Part No.	Description	Remark
R1183	1-216-049-91	RES,CHIP 1K 5%	1/10W	C514	1-163-005-11	CERAMIC CHIP 470PF 10%	50V
R1184	1-216-049-91	RES,CHIP 1K 5%	1/10W	C515	1-107-903-11	ELECT 2.2μF 20%	50V
R1185	1-216-049-91	RES,CHIP 1K 5%	1/10W	C516	1-165-319-11	CERAMIC CHIP 0.1μF	50V
R1186	1-216-295-91	SHORT 0 (D9H5)		C517	1-107-823-11	CERAMIC CHIP 0.47μF 10%	16V
R1187	1-216-295-91	SHORT 0 (D9H5)		C518	1-164-004-11	CERAMIC CHIP 0.1μF 10%	25V
R1188	1-216-295-91	SHORT 0 (D9H5)		C519	1-164-343-11	CERAMIC CHIP 0.056μF 10%	25V
R1189	1-216-295-91	SHORT 0 (D9H5)		C520	1-163-031-11	CERAMIC CHIP 0.01μF	50V
		<RELAY>		C521	1-163-241-11	CERAMIC CHIP 39PF 5%	50V
RY1101	1-515-716-11	RELAY (TQ2-5V) (D9H1)		C522	1-165-319-11	CERAMIC CHIP 0.1μF	50V
RY1102	1-515-716-11	RELAY (TQ2-5V) (D9H1)		C523	1-126-964-11	ELECT 10μF	50V
		<SWITCH>		C524	1-163-121-00	CERAMIC CHIP 150PF 5%	50V
S1101	1-771-815-11	SWITCH, LEVER		C525	1-115-339-11	CERAMIC CHIP 0.1μF 10%	50V
S1102	1-762-712-11	SWITCH, SLIDE (D9H1)		C526	1-163-031-11	CERAMIC CHIP 0.01μF	50V
		<THERMISTOR>		C527	1-107-906-11	ELECT 10μF 20%	50V
TH1100	1-533-817-21	THERMISTOR		C528	1-104-664-11	ELECT 47μF 20%	25V
		<TEST PIN>		C529	1-163-133-00	CERAMIC CHIP 470PF 5%	50V
TP1100	* 1-537-864-11	PIN, POST		C530	1-165-319-11	CERAMIC CHIP 0.1μF	50V
TP1101	* 1-537-864-11	PIN, POST		C531	1-164-004-11	CERAMIC CHIP 0.1μF 10%	25V
TP1102	* 1-537-864-11	PIN, POST		C532	1-107-955-11	ELECT 100μF 20%	200V
TP1103	* 1-537-864-11	PIN, POST		C533	1-107-906-11	ELECT 10μF 20%	50V
TP1104	* 1-537-864-11	PIN, POST		C534	1-162-318-11	CERAMIC 0.001μF 10%	500V
TP1106	* 1-537-864-11	PIN, POST		C535	1-107-995-11	ELECT 100μF	160V
TP1107	* 1-537-864-11	PIN, POST		C536	1-107-364-11	MYLAR 0.01μF 10%	200V
TP1108	* 1-537-864-11	PIN, POST		C537	1-163-031-11	CERAMIC CHIP 0.01μF	50V
TP1109	* 1-537-864-11	PIN, POST		C538	1-126-963-11	ELECT 4.7μF 20%	50V
TP1110	* 1-537-864-11	PIN, POST		C539	1-117-644-11	FILM 10000PF 3%	1.2KV
TP1111	* 1-537-864-11	PIN, POST		C540	1-107-746-51	ELECT 10μF 20%	200V
TP1112	* 1-537-864-11	PIN, POST		C541	1-107-746-51	ELECT 10μF 20%	200V
TP1113	* 1-537-864-11	PIN, POST		C542	1-137-591-91	FILM 0.0082μF 5%	800V
		<CRYSTAL>		C543	1-104-664-11	ELECT 47μF 20%	25V
X1100	1-767-280-21	VIBRATOR, CRYSTAL (3.6864 MHz)		C544	1-108-385-91	MYLAR 0.047μH 10%	100V
		*****		C545	1-115-522-11	FILM 1μF 5%	250V
* A-1195-156-A	P COMPL	*****		C546	1-165-319-11	CERAMIC CHIP 0.1μF	50V
△4-051-742-01	SHEET, INSULATE			C547	1-163-031-11	CERAMIC CHIP 0.01μF	50V
4-382-854-01	SCREW (M3X8), P, SW (+)			C548	1-163-038-91	CERAMIC CHIP 0.1μF	25V
4-382-854-11	SCREW (M3X10), P, SW (+)			C549	1-163-031-11	CERAMIC CHIP 0.01μF	50V
7-682-647-09	SCREW +PS 3X6			C550	1-163-031-11	CERAMIC CHIP 0.01μF	50V
		<CAPACITOR>		C551	1-163-031-11	CERAMIC CHIP 0.01μF	50V
C501	1-107-907-11	ELECT 22μF 20%	25V	C552	1-107-954-91	ELECT 47μF 20%	200V
C502	1-163-038-91	CERAMIC CHIP 0.1μF	25V	C553	1-102-228-00	CERAMIC 470PF 10%	500V
C503	1-107-888-11	ELECT 47μF 20%	25V	C554	1-126-968-11	ELECT 100μF 20%	50V
C504	1-164-343-11	CERAMIC CHIP 0.056μF 10%	25V	C555	1-162-318-11	CERAMIC 0.001μF 10%	500V
C505	1-107-906-11	ELECT 10μF 20%	50V	C556	1-162-318-11	CERAMIC 0.001μF 10%	500V
C506	1-163-031-11	CERAMIC CHIP 0.01μF	50V	C557	1-111-116-11	ELECT 100μF 20%	50V
C508	1-163-031-11	CERAMIC CHIP 0.01μF	50V	C558	1-126-964-11	ELECT 10μF 20%	50V
C509	1-163-021-91	CERAMIC CHIP 0.01μF 10%	50V	C559	1-163-263-11	CERAMIC CHIP 330PF 5%	50V
C510	1-107-909-11	ELECT 47μF 20%	16V	C560	1-130-471-00	MYLAR 0.001μF 5%	50V
C511	1-163-133-00	CERAMIC CHIP 470PF 5%	50V	C561	1-163-031-11	CERAMIC CHIP 0.01μF	50V
C512	1-107-902-11	ELECT 1μF 20%	50V	C562	1-104-664-11	ELECT 47μF 20%	25V
C513	1-163-121-00	CERAMIC CHIP 150PF 5%	50V	C563	1-115-732-11	ELECT 330μF 20%	6.3V
				C564	1-137-150-11	MYLAR 0.01μF 10%	100V
				C565	1-137-150-11	MYLAR 0.01μF 10%	100V
				C566	1-163-031-11	CERAMIC CHIP 0.01μF	50V
				C567	1-163-031-11	CERAMIC CHIP 0.01μF	50V
				C568	1-115-789-11	ELECT 0.001F 20%	25V
				C569	1-163-031-11	CERAMIC CHIP 0.01μF	50V
				C570	1-163-031-11	CERAMIC CHIP 0.01μF	50V
				C571	1-163-021-91	CERAMIC CHIP 0.01μF 10%	50V
				C572	1-107-902-11	ELECT 1μF 20%	50V
				C574	1-163-809-11	CERAMIC CHIP 0.047μF 10%	25V
				C575	1-107-823-11	CERAMIC CHIP 0.47μF 10%	16V
				C576	1-136-161-00	MYLAR 0.047μF 5%	50V
				C577	1-136-165-00	MYLAR 0.1μF 5%	50V
				C578	1-107-902-11	ELECT 1μF 20%	50V
				C579	1-107-909-11	ELECT 47μF 20%	16V
				C581	1-128-526-11	ELECT 100μF 20%	16V



Ref.No.	Part No.	Description	Remark	Ref.No.	Part No.	Description	Remark	
C583	1-107-995-11	ELECT	100μF	160V	IC506	8-759-185-47	IC IR2112	
C584	1-107-889-11	ELECT	220μF	20%	25V	IC507	8-759-198-31	IC UPC1093J-1-T
C585	1-104-653-11	ELECT	220μF	20%	16V	IC508	8-759-502-80	IC LM358M
C587	1-163-021-91	CERAMIC CHIP	0.01μF	10%	50V	IC509	8-759-502-84	IC LM393M
C588	1-163-021-91	CERAMIC CHIP	0.01μF	10%	50V	IC510	8-759-337-67	IC NJM2360AM(TE2)
C589	1-163-021-91	CERAMIC CHIP	0.01μF	10%	50V	IC511	8-759-502-80	IC LM358M
C590	1-163-021-91	CERAMIC CHIP	0.01μF	10%	50V			
C592	1-107-888-91	ELECT	47μF	20%	25V			<COIL>
		<CONNECTOR>			L504	1-406-663-21	INDUCTOR	47μH
CN501	* 1-564-712-11	PIN, CONNECTOR (SMALL TYPE)	10P		L505	1-419-346-11	COIL, CHOKE	
CN502	* 1-564-508-11	PLUG, CONNECTOR	5P		L507	1-406-661-11	INDUCTOR	22μH
CN503	* 1-691-960-11	PIN, CONNECTOR (PC BOARD)	3P		L508	1-408-623-21	INDUCTOR	470μH
CN505	* 1-564-509-11	PLUG, CONNECTOR	6P					<NEON LAMP>
CN506	* 1-564-711-11	PIN, CONNECTOR (SMALL TYPE)	9P		NL501	1-519-526-11	LAMP, NEON	
		<DIODE>			NL502	1-519-526-11	LAMP, NEON	
D501	8-719-073-01	DIODE MA111-(K8).S0						<TRANSISTOR>
D502	8-719-073-01	DIODE MA111-(K8).S0			Q502	8-729-027-23	TRANSISTOR DTA114EKA-T146	
D503	8-719-158-49	DIODE RD12SB2			Q503	1-801-806-11	TRANSISTOR DTC144EKA-T146	
D504	8-719-073-01	DIODE MA111-(K8).S0			Q504	1-801-806-11	TRANSISTOR DTC144EKA-T146	
D505	8-719-158-49	DIODE RD12SB2			Q505	8-729-027-38	TRANSISTOR DTA144EKA-T146	
D506	8-719-158-49	DIODE RD12SB2			Q506	8-729-019-85	TRANSISTOR 2SC3392-5-TB	
D507	8-719-158-40	DIODE RD10SB1			Q507	8-729-120-28	TRANSISTOR 2SC1623-L5L6	
D508	8-719-073-01	DIODE MA111-(K8).S0			Q508	8-729-026-49	TRANSISTOR 2SA1037AK-T146-R	
D509	8-719-989-21	DIODE SC311-6-TE12RA			Q509	8-729-824-24	TRANSISTOR 2SA1338-5-TB	
D510	8-719-073-01	DIODE MA111-(K8).S0			Q510	8-729-019-85	TRANSISTOR 2SC3392-5-TB	
D511	8-719-107-15	DIODE RD18M-T1B2			Q511	8-729-019-85	TRANSISTOR 2SC3392-5-TB	
D512	8-719-073-01	DIODE MA111-(K8).S0			Q512	8-729-026-49	TRANSISTOR 2SA1037AK-T146-R	
D513	8-719-073-01	DIODE MA111-(K8).S0			Q513	8-729-824-24	TRANSISTOR 2SA1338-5-TB	
D514	8-719-073-01	DIODE MA111-(K8).S0			Q514	8-729-019-85	TRANSISTOR 2SC3392-5-TB	
D515	8-719-989-21	DIODE SC311-6-TE12RA			Q515	8-729-050-47	TRANSISTOR 2SK3110	
D516	8-719-073-01	DIODE MA111-(K8).S0			Q516	8-729-120-28	TRANSISTOR 2SC1623-L5L6	
D517	8-719-073-01	DIODE MA111-(K8).S0			Q517	8-729-926-77	TRANSISTOR IRF1640	
D518	8-719-073-01	DIODE MA111-(K8).S0			Q518	8-729-926-77	TRANSISTOR IRF1640	
D519	8-719-073-01	DIODE MA111-(K8).S0			Q519	8-729-026-49	TRANSISTOR 2SA1037AK-T146-R	
D520	8-719-029-04	DIODE D5L60			Q520	8-729-050-71	TRANSISTOR IRFPE50LF20	
D521	8-719-073-01	DIODE MA111-(K8).S0			Q521	8-729-027-38	TRANSISTOR DTA144EKA-T146	
D522	8-719-073-01	DIODE MA111-(K8).S0			Q522	8-729-120-28	TRANSISTOR 2SC1623-L5L6	
D523	8-719-110-67	DIODE RD27ESB2			Q523	8-729-026-49	TRANSISTOR 2SA1037AK-T146-R	
D524	8-719-110-67	DIODE RD27ESB2			Q524	1-801-806-11	TRANSISTOR DTC144EKA-T146	
D525	8-719-302-43	DIODE EL1Z			Q525	8-729-033-25	TRANSISTOR DTC114GKA	
D526	8-719-302-43	DIODE EL1Z			Q526	8-729-026-49	TRANSISTOR 2SA1037AK-T146-R	
D527	8-719-302-43	DIODE EL1Z			Q527	8-729-032-54	TRANSISTOR IRF1840LF38	
D528	8-719-073-01	DIODE MA111-(K8).S0			Q528	1-801-806-11	TRANSISTOR DTC144EKA-T146	
D529	8-719-073-01	DIODE MA111-(K8).S0			Q529	8-729-027-38	TRANSISTOR DTA144EKA-T146	
D530	8-719-210-43	DIODE EC10QS-06			Q530	1-801-806-11	TRANSISTOR DTC144EKA-T146	
D531	8-719-110-67	DIODE RD27ESB2						<RESISTOR>
D532	8-719-037-53	DIODE RD27SB-T1			R503	1-216-075-00	RES,CHIP	12K 5% 1/10W
D533	8-719-073-01	DIODE MA111-(K8).S0			R504	1-216-025-91	RES,CHIP	100 5% 1/10W
D534	8-719-073-01	DIODE MA111-(K8).S0			R505	1-216-077-91	RES,CHIP	15K 5% 1/10W
D535	8-719-158-57	DIODE RD15SB2			R506	1-216-081-00	RES,CHIP	22K 5% 1/10W
D536	8-719-073-01	DIODE MA111-(K8).S0			R507	1-216-659-11	METAL CHIP	2.2K 0.50% 1/10W
D537	8-719-110-02	DIODE RD7.5ESB1			R508	1-216-685-11	METAL CHIP	27K 0.50% 1/10W
D538	8-719-033-53	DIODE RD6.8SB2-T1			R509	1-216-017-91	RES,CHIP	47 5% 1/10W
D539	8-719-073-01	DIODE MA111-(K8).S0			R510	1-216-053-00	RES,CHIP	1.5K 5% 1/10W
		<IC>			R511	1-249-381-11	CARBON	1 5% 1/4W F
IC501	8-759-209-69	IC TC4S11F			R512	1-216-097-91	RES,CHIP	100K 5% 1/10W
IC502	8-759-158-82	IC CXA1544M-T6			R513	1-216-009-91	RES,CHIP	22 5% 1/10W
IC503	8-759-914-04	IC TL494CNS			R514	1-216-101-00	RES,CHIP	150K 5% 1/10W
IC504	△ 8-759-198-31	IC UPC1093J-1-T			R515	1-216-025-91	RES,CHIP	100 5% 1/10W
IC505	8-759-209-69	IC TC4S11F						

Ref.No.	Part No.	Description	Remark	Ref.No.	Part No.	Description	Remark
R516	1-216-025-91	RES,CHIP	100 5% 1/10W	R582	1-216-693-11	METAL CHIP	56K 0.50% 1/10W
R517	1-216-073-00	RES,CHIP	10K 5% 1/10W	R583	1-216-687-11	METAL CHIP	33K 0.50% 1/10W
R518	1-216-097-91	RES,CHIP	100K 5% 1/10W	R584	1-216-690-11	METAL CHIP	43K 0.50% 1/10W
R519	1-216-081-00	RES,CHIP	22K 5% 1/10W	R585	1-216-651-11	METAL CHIP	1K 0.50% 1/10W
R520	1-216-089-91	RES,CHIP	47K 5% 1/10W	R586	1-216-685-11	METAL CHIP	27K 0.50% 1/10W
R521	1-216-073-00	RES,CHIP	10K 5% 1/10W	R587	1-218-756-11	METAL CHIP	150K 0.50% 1/10W
R522	1-216-049-91	RES,CHIP	1K 5% 1/10W	R588	1-218-768-11	METAL CHIP	470K 0.50% 1/10W
R523	1-216-073-00	RES,CHIP	10K 5% 1/10W	R589	1-249-377-11	CARBON	0.47 5% 1/4W F
R524	1-216-073-00	RES,CHIP	10K 5% 1/10W	R590	1-249-377-11	CARBON	0.47 5% 1/4W F
R525	1-216-057-00	RES,CHIP	2.2K 5% 1/10W	R591	1-249-377-11	CARBON	0.47 5% 1/4W F
R526	1-216-073-00	RES,CHIP	10K 5% 1/10W	R592	1-249-377-11	CARBON	0.47 5% 1/4W F
R527	1-216-025-91	RES,CHIP	100 5% 1/10W	R593	1-216-677-11	METAL CHIP	12K 0.50% 1/10W
R528	1-216-083-00	RES,CHIP	27K 5% 1/10W	R594	1-216-073-00	RES,CHIP	10K 5% 1/10W
R529	1-216-063-91	RES,CHIP	3.9K 5% 1/10W	R595	1-216-081-00	RES,CHIP	22K 5% 1/10W
R530	1-216-009-91	RES,CHIP	22 5% 1/10W	R596	1-216-081-00	RES,CHIP	22K 5% 1/10W
R531	1-216-667-11	METAL CHIP	4.7K 0.50% 1/10W	R597	1-216-067-00	RES,CHIP	5.6K 5% 1/10W
R532	1-216-659-11	METAL CHIP	2.2K 0.50% 1/10W	R598	1-216-073-00	RES,CHIP	10K 5% 1/10W
R533	1-216-685-11	METAL CHIP	27K 0.50% 1/10W	R599	1-216-097-91	RES,CHIP	100K 5% 1/10W
R534	1-216-667-11	METAL CHIP	4.7K 0.50% 1/10W	R1501	1-216-653-11	METAL CHIP	1.2K 0.50% 1/10W
R535	1-216-683-11	METAL CHIP	22K 0.50% 1/10W	R1502	1-216-629-11	METAL CHIP	120 0.50% 1/10W
R536	1-216-687-11	METAL CHIP	33K 0.50% 1/10W	R1503	1-216-662-11	METAL CHIP	3K 0.50% 1/10W
R537	1-216-073-00	RES,CHIP	10K 5% 1/10W	R1504	1-216-663-11	METAL CHIP	3.3K 0.50% 1/10W
R538	1-216-043-91	RES,CHIP	560 5% 1/10W	R1505	1-216-663-11	METAL CHIP	3.3K 0.50% 1/10W
R539	1-216-651-11	METAL CHIP	1K 0.50% 1/10W	R1506	1-216-663-11	METAL CHIP	3.3K 0.50% 1/10W
R540	1-216-675-91	METAL CHIP	10K 0.50% 1/10W	R1507	1-216-673-11	METAL CHIP	8.2K 0.50% 1/10W
R541	1-216-675-91	METAL CHIP	10K 0.50% 1/10W	R1508	1-216-663-11	METAL CHIP	3.3K 0.50% 1/10W
R543	1-216-057-00	RES,CHIP	2.2K 5% 1/10W	R1509	1-216-663-11	METAL CHIP	3.3K 0.50% 1/10W
R544	1-216-057-00	RES,CHIP	2.2K 5% 1/10W	R1510	1-219-759-11	CARBON	1M 5% 1/2W
R545	1-216-073-00	RES,CHIP	10K 5% 1/10W	R1511	1-216-067-00	RES,CHIP	5.6K 5% 1/10W
R546	1-216-073-00	RES,CHIP	10K 5% 1/10W	R1512	1-216-073-00	RES,CHIP	10K 5% 1/10W
R547	1-216-043-91	RES,CHIP	560 5% 1/10W	R1513	1-216-693-91	METAL CHIP	56K 0.50% 1/10W
R548	1-216-073-00	RES,CHIP	10K 5% 1/10W	R1514	1-218-774-11	METAL CHIP	820K 0.50% 1/10W
R549	△1-216-689-11	METAL CHIP	39K 0.50% 1/10W	R1515	1-216-073-00	RES,CHIP	10K 5% 1/10W
R550	1-216-295-91	SHORT	0	R1516	1-215-879-11	METAL OXIDE	47K 5% 1W F
R551	1-216-065-91	RES,CHIP	4.7K 5% 1/10W	R1517	1-216-081-00	RES,CHIP	22K 5% 1/10W
R552	1-216-081-00	RES,CHIP	22K 5% 1/10W	R1518	1-215-437-00	METAL	4.7K 1% 1/4W
R553	1-216-065-91	RES,CHIP	4.7K 5% 1/10W	R1519	1-218-753-11	METAL CHIP	110K 0.50% 1/10W
R554	1-216-081-00	RES,CHIP	22K 5% 1/10W	R1520	1-216-073-00	RES,CHIP	10K 5% 1/10W
R555	△1-218-758-11	METAL CHIP	180K 0.50% 1/10W	R1521	1-219-510-11	CARBON	470K 5% 1/2W
R556	1-216-067-00	RES,CHIP	5.6K 5% 1/10W	R1522	1-216-657-11	METAL CHIP	1.8K 0.50% 1/10W
R557	1-216-065-91	RES,CHIP	4.7K 5% 1/10W	R1523	1-216-295-91	SHORT	0
R558	1-216-049-91	RES,CHIP	1K 5% 1/10W	R1524	1-218-768-11	METAL CHIP	470K 0.50% 1/10W
R559	1-216-063-91	RES,CHIP	3.9K 5% 1/10W	R1526	1-216-025-91	RES,CHIP	100 5% 1/10W
R560	1-216-073-00	RES,CHIP	10K 5% 1/10W	R1527	1-218-768-11	METAL CHIP	470K 0.50% 1/10W
R561	1-216-089-91	RES,CHIP	47K 5% 1/10W	R1529	1-216-675-91	METAL CHIP	10K 0.50% 1/10W
R562	1-216-065-91	RES,CHIP	4.7K 5% 1/10W	R1530	1-247-885-91	RES	180K 5% 1/4W
R563	1-216-675-91	METAL CHIP	10K 0.50% 1/10W	R1531	1-216-113-00	RES,CHIP	470K 5% 1/10W
R564	1-218-756-11	METAL CHIP	150K 0.50% 1/10W	R1532	1-216-683-11	METAL CHIP	22K 0.5% 1/10W
R565	1-216-065-91	RES,CHIP	4.7K 5% 1/10W	R1533	1-216-675-91	METAL CHIP	10K 0.5% 1/10W
R566	1-216-073-00	RES,CHIP	10K 5% 1/10W	<TRANSFORMER>			
R567	1-216-001-00	RES,CHIP	10 5% 1/10W	T501	1-435-156-11	TRANSFORMER, FERRITE	
R568	1-219-718-11	CEMENTED	0.1 10% 5W	T502	△1-439-526-21	TRANSFORMER ASSY, FLYBACK	
R569	1-216-001-00	RES,CHIP	10 5% 1/10W	<THERMISTOR>			
R570	1-216-001-00	RES,CHIP	10 5% 1/10W	TH501	1-807-973-11	THERMISTOR	
R571	1-216-073-00	RES,CHIP	10K 5% 1/10W	*****			
R572	1-216-073-00	RES,CHIP	10K 5% 1/10W				
R573	1-216-067-00	RES,CHIP	5.6K 5% 1/10W				
R574	1-216-073-00	RES,CHIP	10K 5% 1/10W				
R575	1-216-001-00	RES,CHIP	10 5% 1/10W				
R576	1-216-073-00	RES,CHIP	10K 5% 1/10W				
R577	1-216-661-11	METAL CHIP	2.7K 0.50% 1/10W				
R578	1-216-646-11	METAL CHIP	620 0.50% 1/10W				
R579	1-216-658-11	METAL CHIP	2K 0.50% 1/10W				
R580	1-216-041-00	RES,CHIP	470 5% 1/10W				
R581	1-215-860-11	METAL OXIDE	33 5% 1W F				

Ref.No.	Part No.	Description	Remark
	* A-1390-942-A	T MOUNT *****	
		<CONNECTOR>	
CN801	* 1-564-526-11	PLUG, CONNECTOR 11P	
CN802	1-774-525-11	SOCKET, CONNECTOR 64P	
CN803	1-774-525-11	SOCKET, CONNECTOR 64P	
CN804	1-774-525-11	SOCKET, CONNECTOR 64P	
CN805	* 1-564-523-11	PLUG, CONNECTOR 8P	
CN806	* 1-564-525-11	PLUG, CONNECTOR 10P	
*****			
	* A-1373-751-A	YA MOUNT *****	
		<CONNECTOR>	
CN900	* 1-564-719-11	PIN, CONNECTOR (SMALL TYPE) 3P	
		<DIODE>	
D900	8-719-054-22	DIODE SML-020MLTT87	
D901	8-719-054-22	DIODE SML-020MLTT87	
D902	8-719-054-22	DIODE SML-020MLTT87	
D903	8-719-054-22	DIODE SML-020MLTT87	
D904	8-719-054-22	DIODE SML-020MLTT87	
D905	8-719-054-22	DIODE SML-020MLTT87	
D906	8-719-054-22	DIODE SML-020MLTT87	
D907	8-719-054-22	DIODE SML-020MLTT87	
		<RESISTOR>	
R900	1-216-071-00	RES,CHIP 8.2K 5% 1/10W	
R901	1-216-071-00	RES,CHIP 8.2K 5% 1/10W	
R902	1-216-071-00	RES,CHIP 8.2K 5% 1/10W	
R903	1-216-071-00	RES,CHIP 8.2K 5% 1/10W	
R904	1-216-071-00	RES,CHIP 8.2K 5% 1/10W	
R905	1-216-071-00	RES,CHIP 8.2K 5% 1/10W	
R906	1-216-071-00	RES,CHIP 8.2K 5% 1/10W	
R907	1-216-071-00	RES,CHIP 8.2K 5% 1/10W	
R908	1-216-071-00	RES,CHIP 8.2K 5% 1/10W	
R909	1-216-071-00	RES,CHIP 8.2K 5% 1/10W	
R910	1-216-071-00	RES,CHIP 8.2K 5% 1/10W	
R911	1-216-071-00	RES,CHIP 8.2K 5% 1/10W	
R912	1-216-071-00	RES,CHIP 8.2K 5% 1/10W	
R913	1-216-071-00	RES,CHIP 8.2K 5% 1/10W	
R914	1-216-071-00	RES,CHIP 8.2K 5% 1/10W	
R915	1-216-071-00	RES,CHIP 8.2K 5% 1/10W	
*****			
	* A-1373-750-A	YB MOUNT *****	
		<CONNECTOR>	
CN951	* 1-564-726-11	PIN, CONNECTOR (SMALL TYPE)10P	
CN952	1-774-806-11	CONNECTOR, ROUND TYPE (8PIN) (INDICATOR)JACK	

Ref.No.	Part No.	Description	Remark
		<DIODE>	
D951	8-719-060-27	DIODE SLR-325MCT31	
D952	8-719-053-43	DIODE SLR-325VCT31	
D953	8-719-037-22	DIODE RD12SB-T1	
D954	8-719-037-22	DIODE RD12SB-T1	
D955	8-719-037-22	DIODE RD12SB-T1	
D956	8-719-037-22	DIODE RD12SB-T1	
D957	8-719-158-19	DIODE RD6.2SB	
D958	8-719-037-22	DIODE RD12SB-T1	
D959	8-719-037-22	DIODE RD12SB-T1	
*****			
		ACCESSORIES *****	
	X-4037-175-1	BEZEL (4:3) ASSY	
	△ 1-534-827-14	CORD, POWER 10A/125V	
	2-990-242-01	HOLDER (B), PLUG (POWER CORD)	
	3-867-938-01	MANUAL OPERATION (JAPANESE, ENGLISH)	
	4-073-253-01	PLATE, TALLY	

### Section 10 Block Diagrams

Overall (1/2)

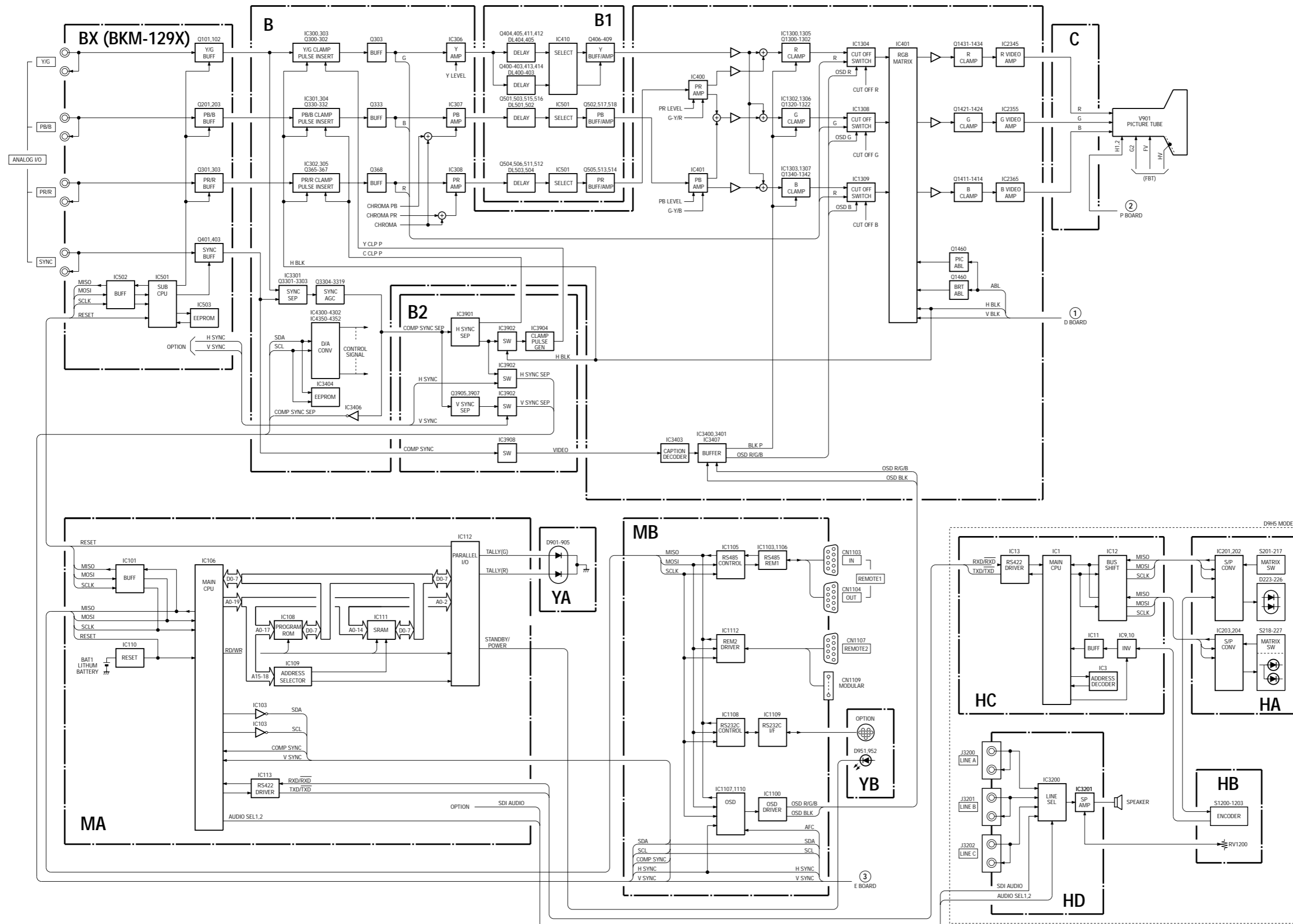

Overall (1/2)

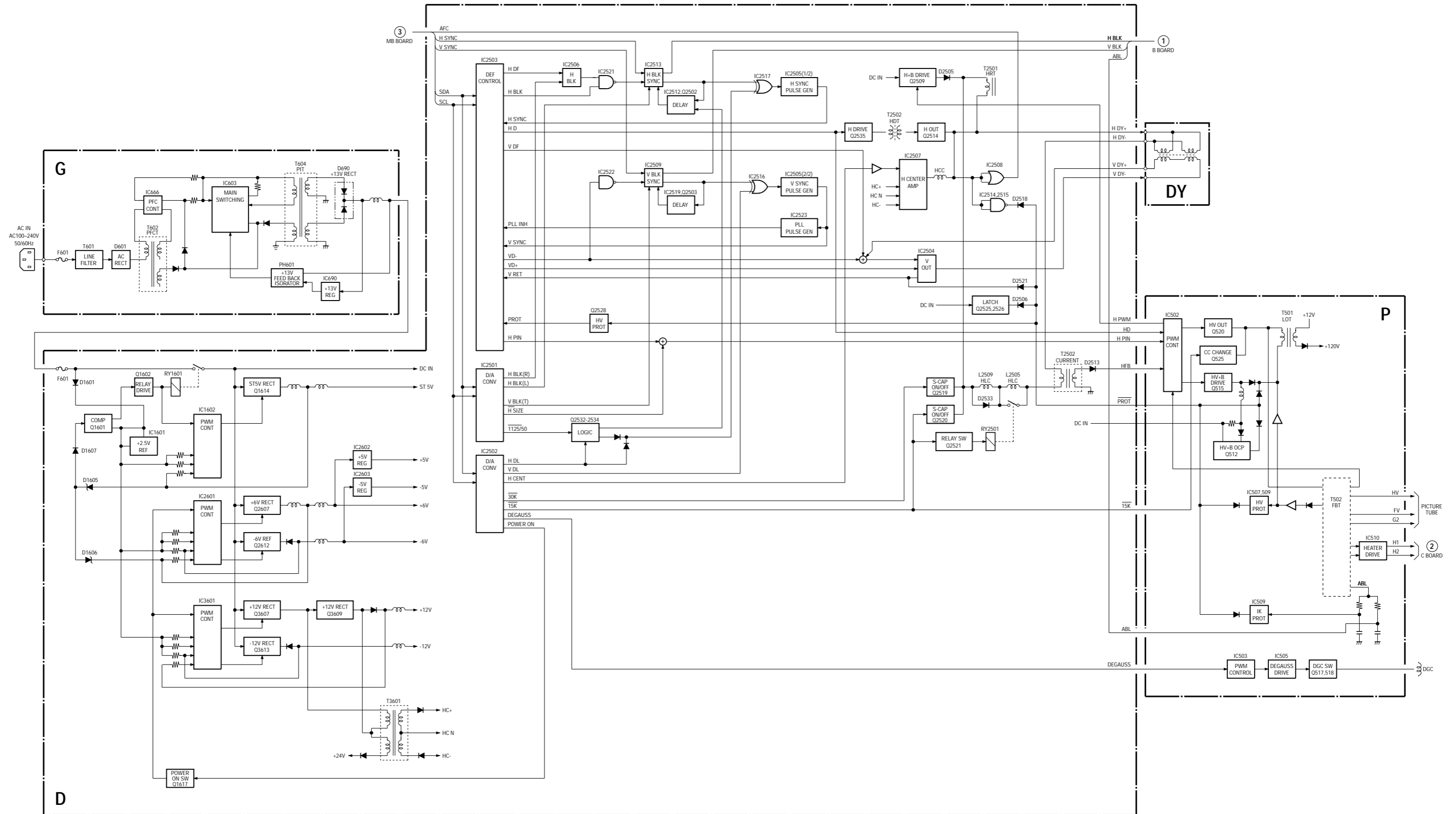



B Block (1/2)  
 BX Block  
 B1 Block  
 B2 Block

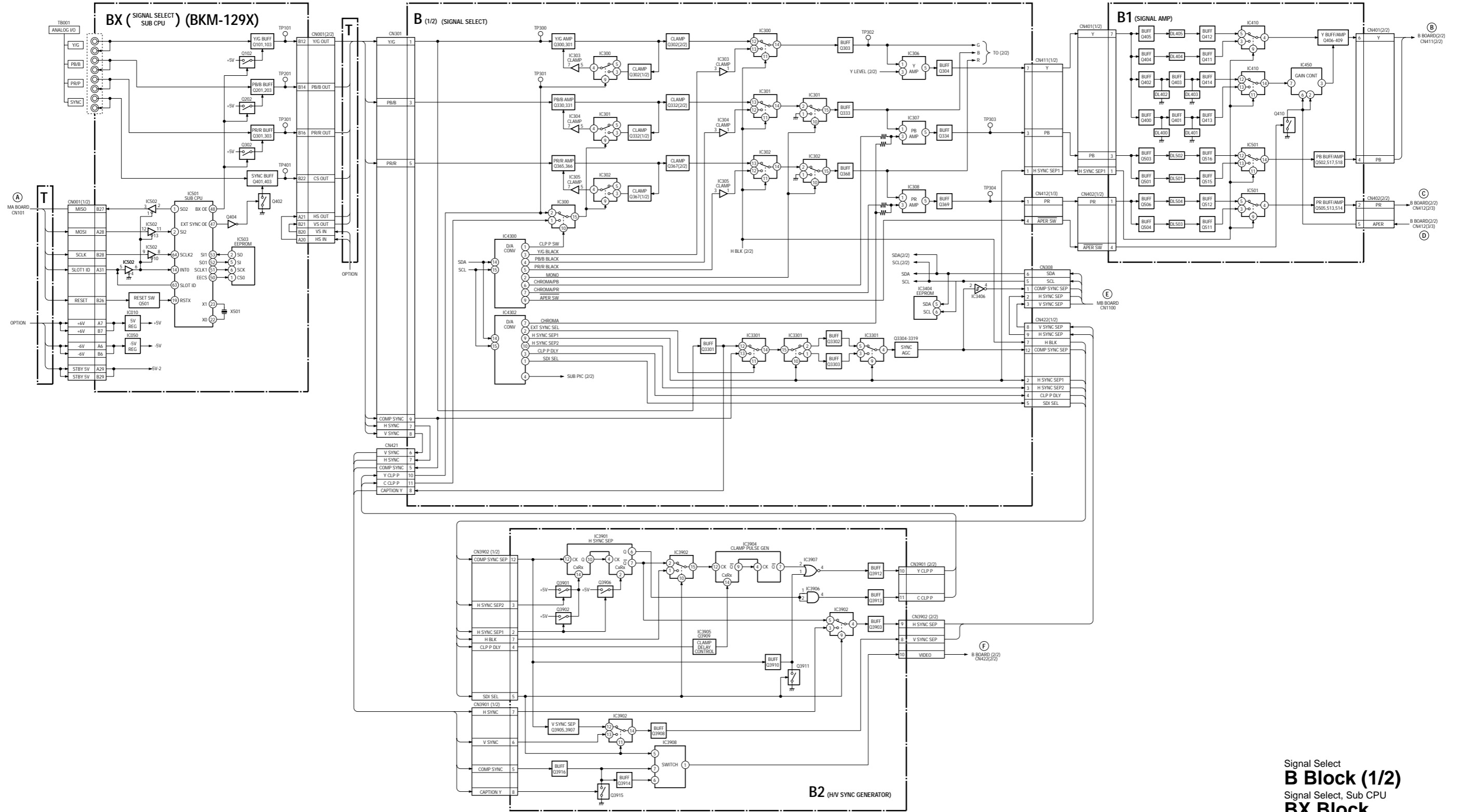

Signal Select  
**B Block (1/2)**  
 Signal Select, Sub CPU  
**BX Block**  
 Signal Amp  
**B1 Block**  
 H/V, Sync Generator  
**B2 Block**

B Block (2/2)  
C Block

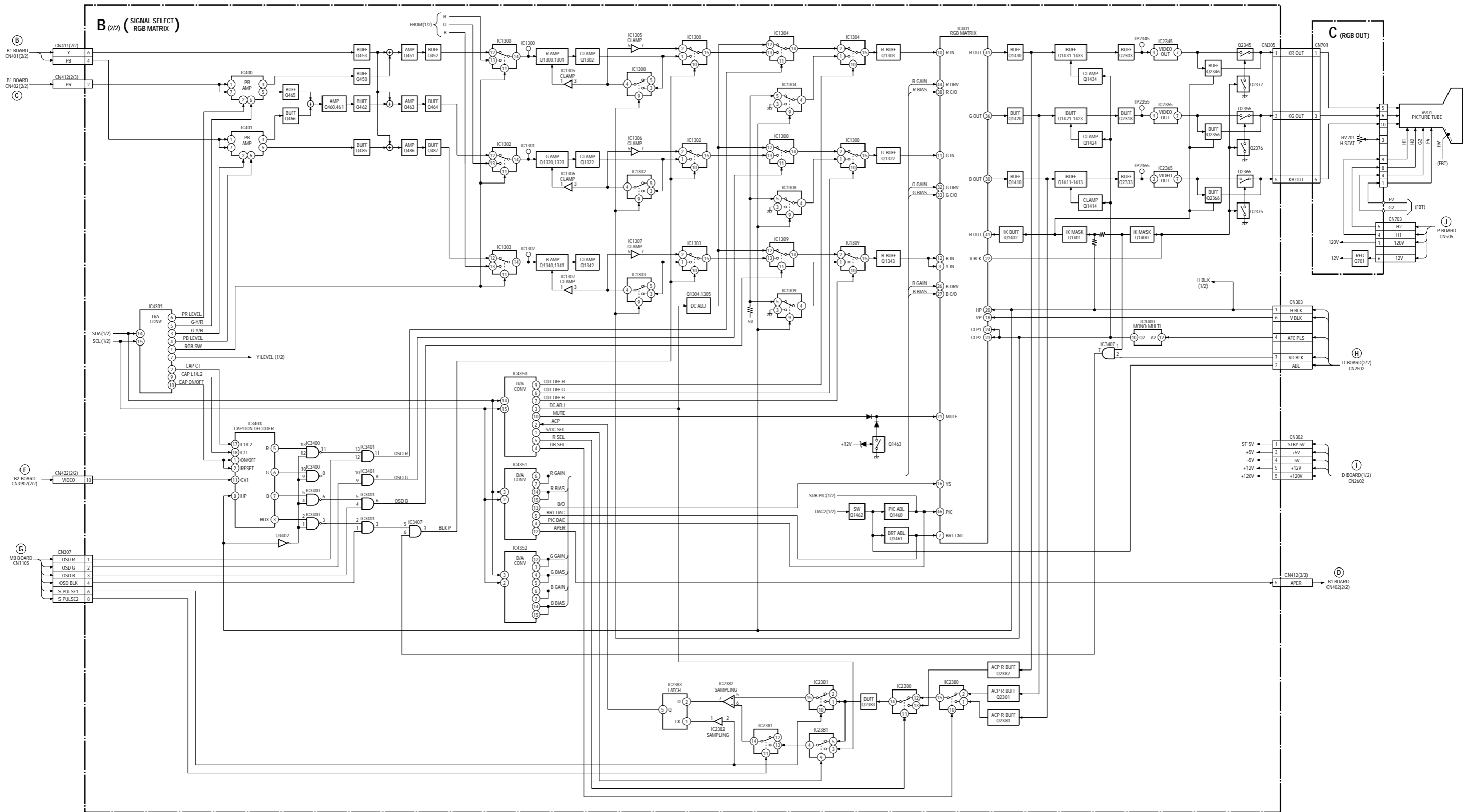

Signal Select, RGB Matrix  
**B Block (2/2)**  
RGB Out  
**C Block**

D Block (1/2)

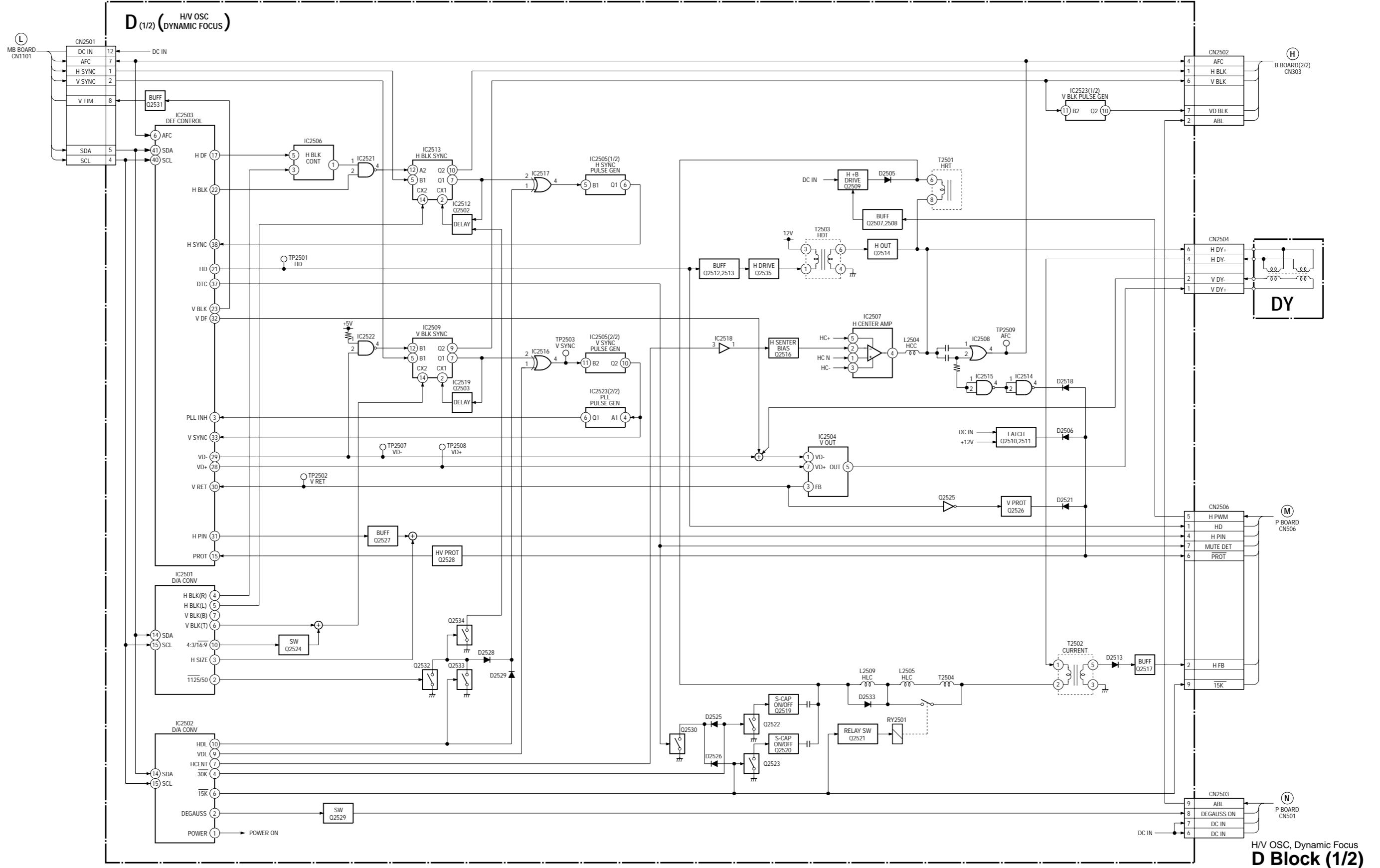

D Block (2/2)  
G1 Block

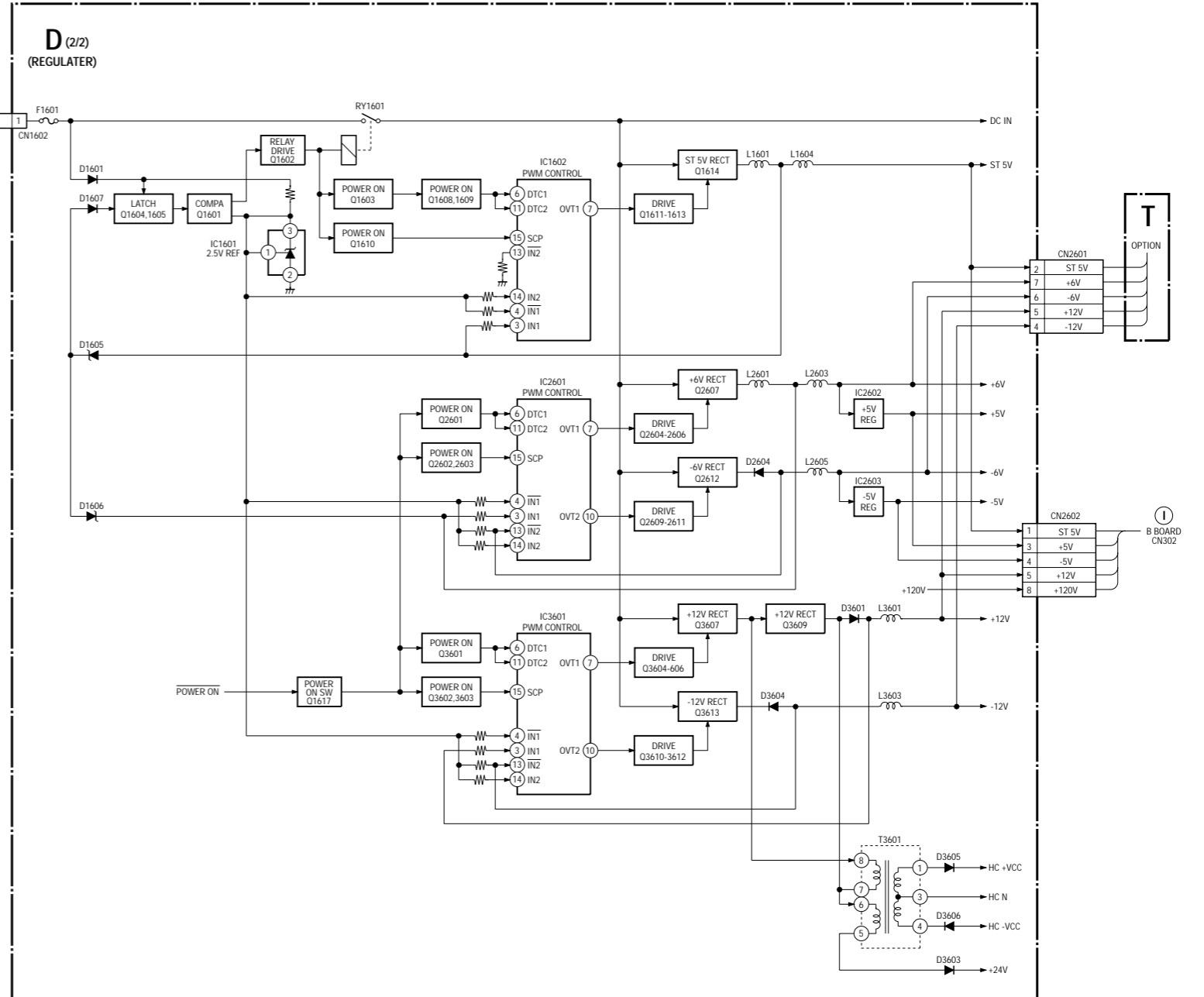
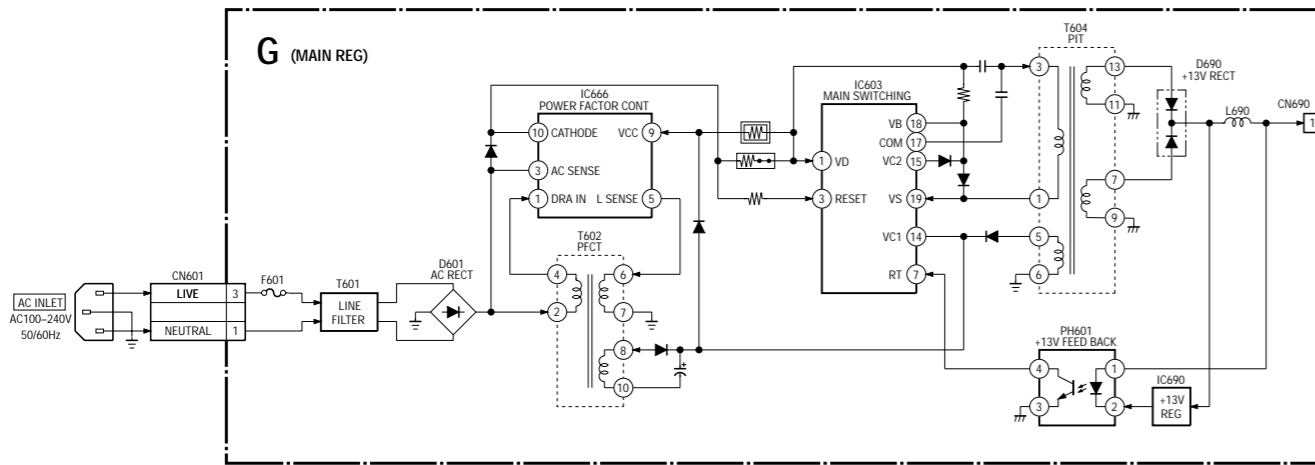

Main Regulator  
**D Block (2/2)**  
Main Regulator  
**G1 Block**

P Block

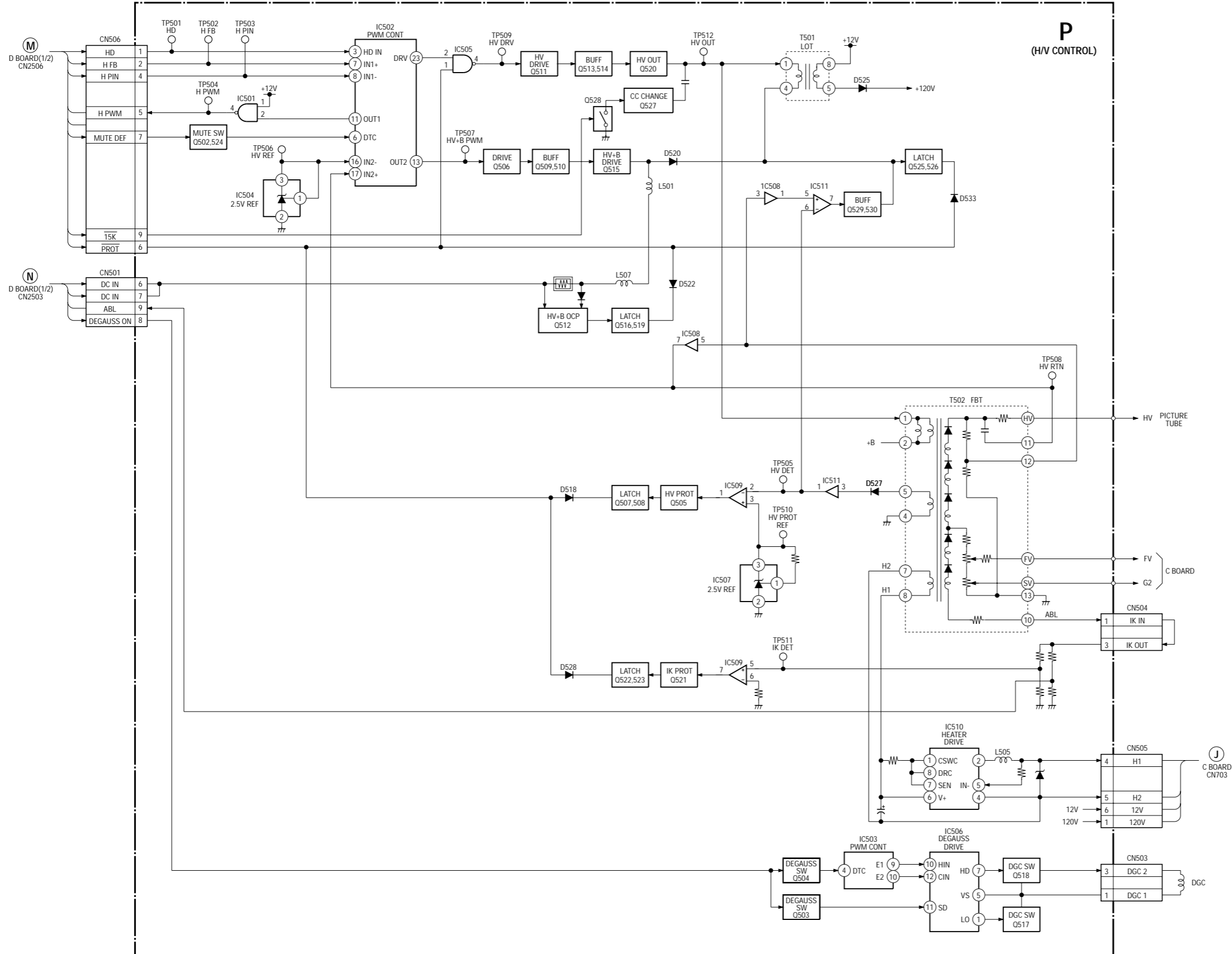

H/V Control P Block

MA Block  
MB Block

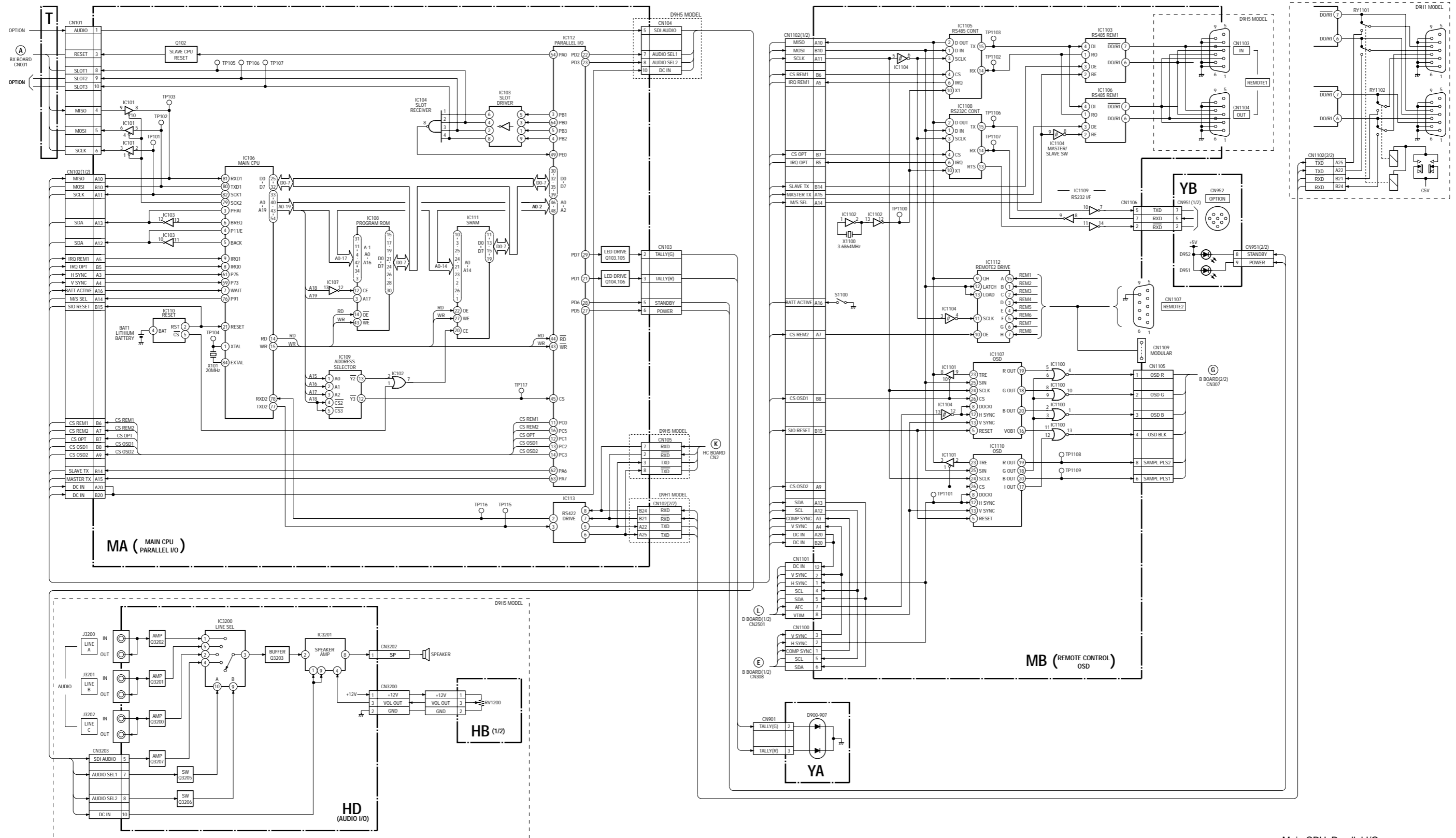

Main CPU, Parallel I/O  
**MA Block**  
Remote Control OSD  
**MB Block**

HA Block  
HB Block  
HC Block

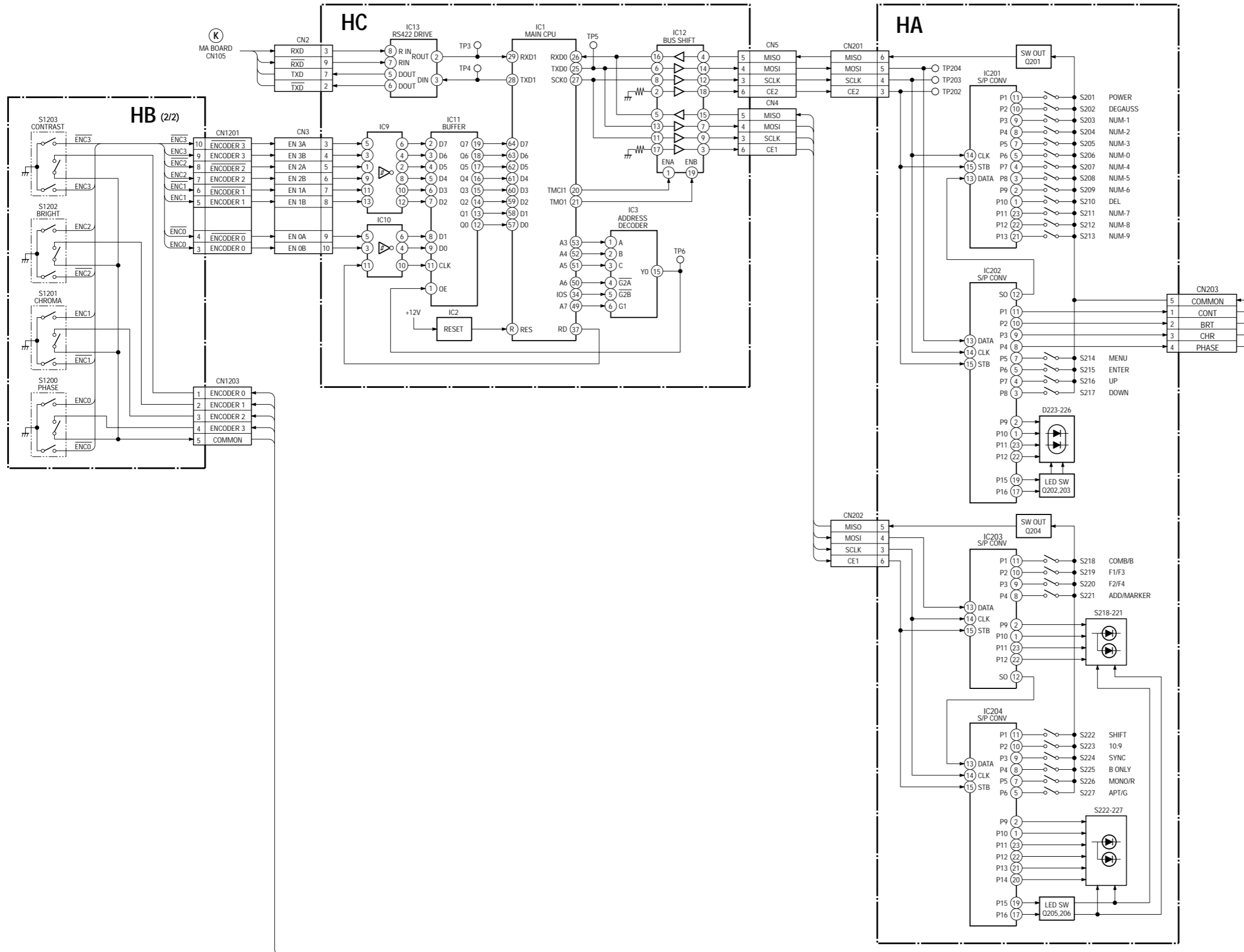



Serial to Parallel Converter  
**HA Block**  
Switch  
**HB Block**  
Main CPU  
**HC Block**







## Section 11 Diagrams

### Note:



- Parts marked “ \* ” differ according to the model/destination. Refer to the mount table for each function.
- The parts marked “ # ” on schematic diagrams are not mounted.
- All capacitors are in  $\mu\text{F}$  unless otherwise noted.  $\text{pF}$ :  $\mu\mu\text{F}$  50WV or less are not indicated except for electrolytics.
- All electrolytics are in 50 V unless otherwise specified.
-  : fusible resistor
-  : nonflammable resistor
- $\Delta$  : internal component
-  : panel designation and adjustment for repair
- Caution when replacing chip parts  
New parts must be attached after removal of the chip.  
Be careful not to heat the minus side of a tantalum capacitor, because it is easily damaged by the heat.

### Reference information

RESISTOR	RN	: METAL FILM
	RC	: SOLID
	FPRD	: NONFLAMMABLE CARBON
	FUSE	: NONFLAMMABLE FUSIBLE
	RS	: NONFLAMMABLE METAL OXIDE
	RB	: NONFLAMMABLE CEMENT
	RW	: NONFLAMMABLE WIREWOUND
	※	: ADJUSTMENT RESISTOR
COIL	LF-8L	: MICRO INDUCTOR
CAPACITOR	TA	: TANTALUM
	PS	: STYROL
	PP	: POLYPROPYLENE
	PT	: MYLAR
	MPS	: METALIZED POLYESTER
	MPP	: METALIZED POLYPROPYLENE
	ALB	: BIPOLAR
	ALT	: HIGH TEMPERATURE
	ALR	: HIGH RIPPLE

- The components marked  in this schematic diagram have been carefully factory-selected for each set in order to satisfy regulations regarding X-ray radiation.
- When replacing components marked , make the necessary adjustments indicated. If results do not meet the specified value, change the component marked  and repeat the adjustment until the specified value is achieved.

### [Measuring conditions, voltage and waveform]

- A voltage value is the reference value between the measurement point and the earth, when the RGB color bar signal is received from the color bar generator (digital multi-meter used: 10 M ohms/ V DC).
- Unit of voltage is V (volt).
-  : B+line
-  : B- line
- Voltage variations may occur due to normal production tolerances.
- RGB color bar signal.
- Circled numbers indicate the reference waveform.
-  : Signal path.

The components identified marked  $\Delta$  are critical for safety.  
Replace only with the part number specified.

Les composants identifiés par la marque  $\Delta$  sont critiques pour la sécurité.  
Ne les remplacer que par une pièce portant le numéro spécifié.



**NOTE:**  
The circuit indicated as shown on the left contains high voltages of over 600 Vp-p. Take care to avoid electric shock during inspection or repair work.

11-1. Frame Schematic Diagram

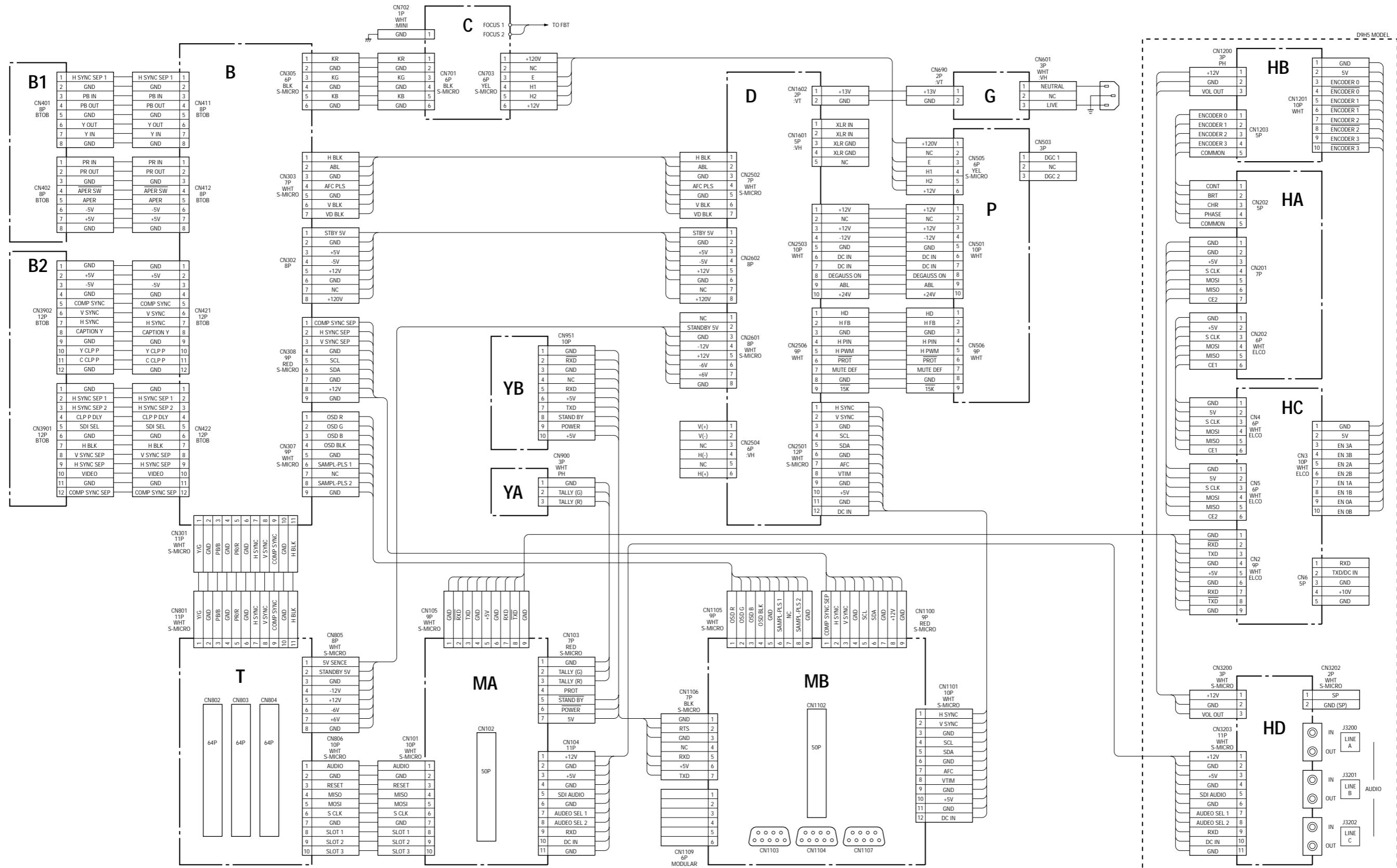

11-2. Schematic Diagrams and Printed Wiring Boards

BX BOARD

[BX BOARD]

\* : B SIDE

D101	A-1
D102	C-2
D201	A-2
D202	C-3
D301	A-3
D302	C-3
D401	A-4
D402	C-3
D501	C-5
IC010	B-1
IC050	C-1
IC501	B-4
IC502	C-4
IC503	B-5
Q101	A-1
Q102	B-2
Q103	C-2
Q201	A-2
Q202	B-3
Q203	C-3
Q301	A-3
Q302	B-4
Q303	C-3
Q401	A-4
Q402	B-4
Q403	C-3
Q404	B-5
Q501	C-4
TP001	B-2
TP010	B-4
TP101	C-2
TP201	C-3
TP301	C-3
TP401	C-3

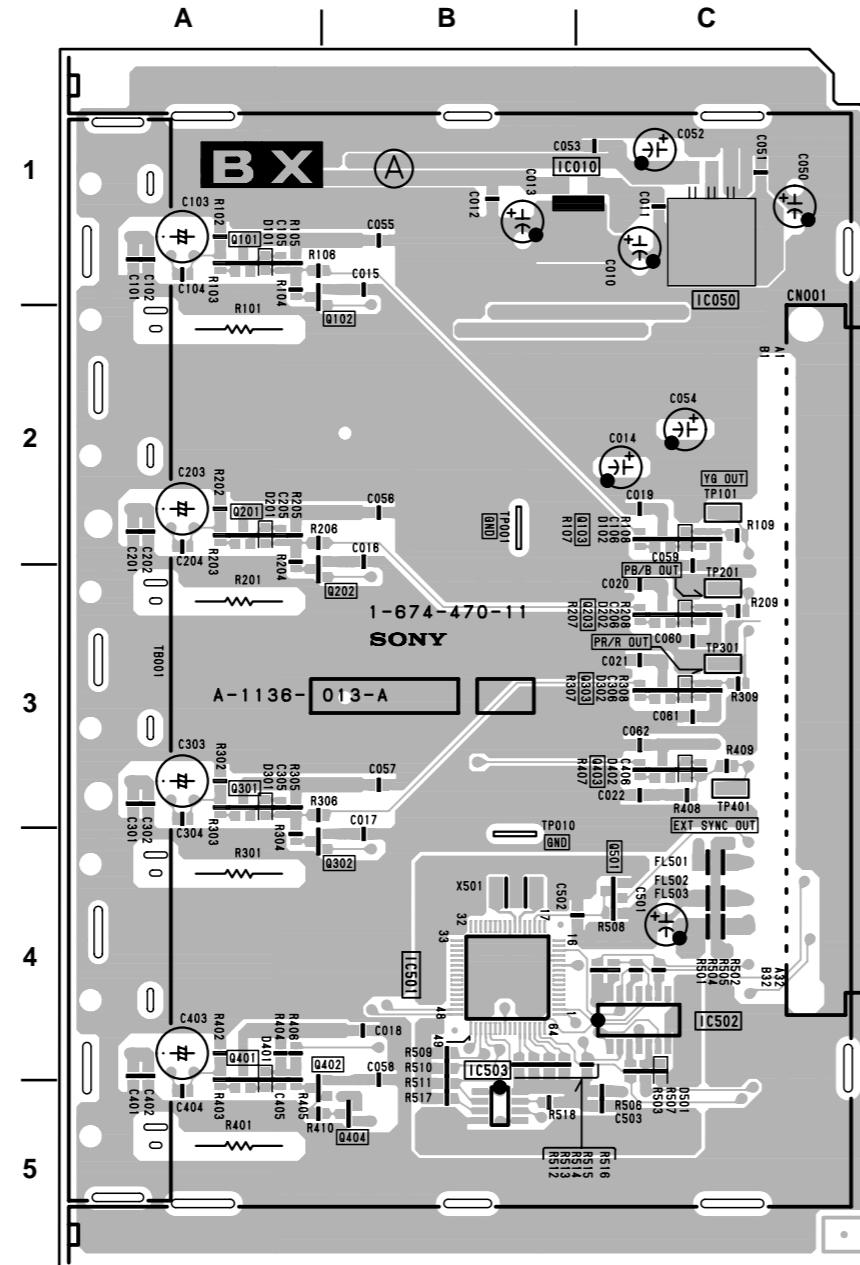

BX -A SIDE-  
SUFFIX: -11

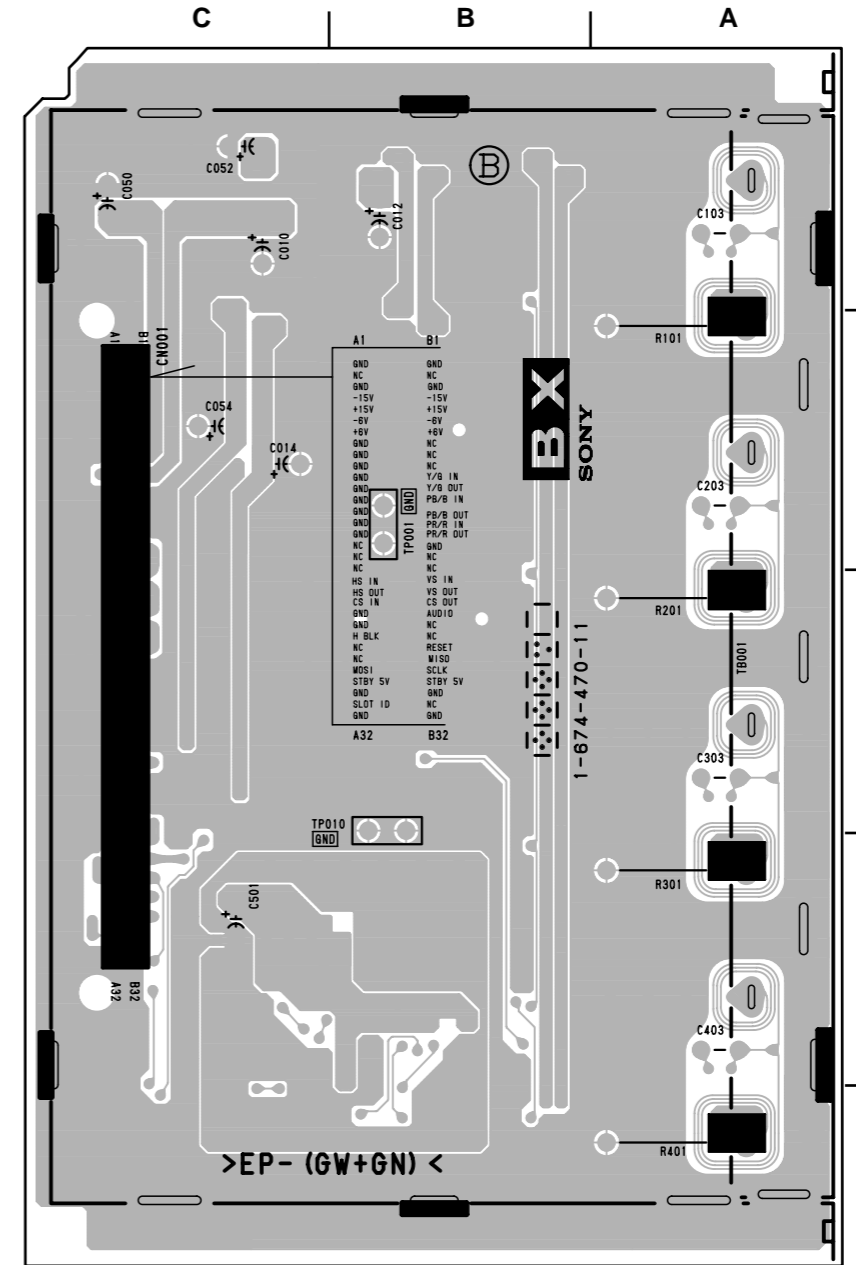

BX -B SIDE-  
SUFFIX: -11

1

2

3

4

5

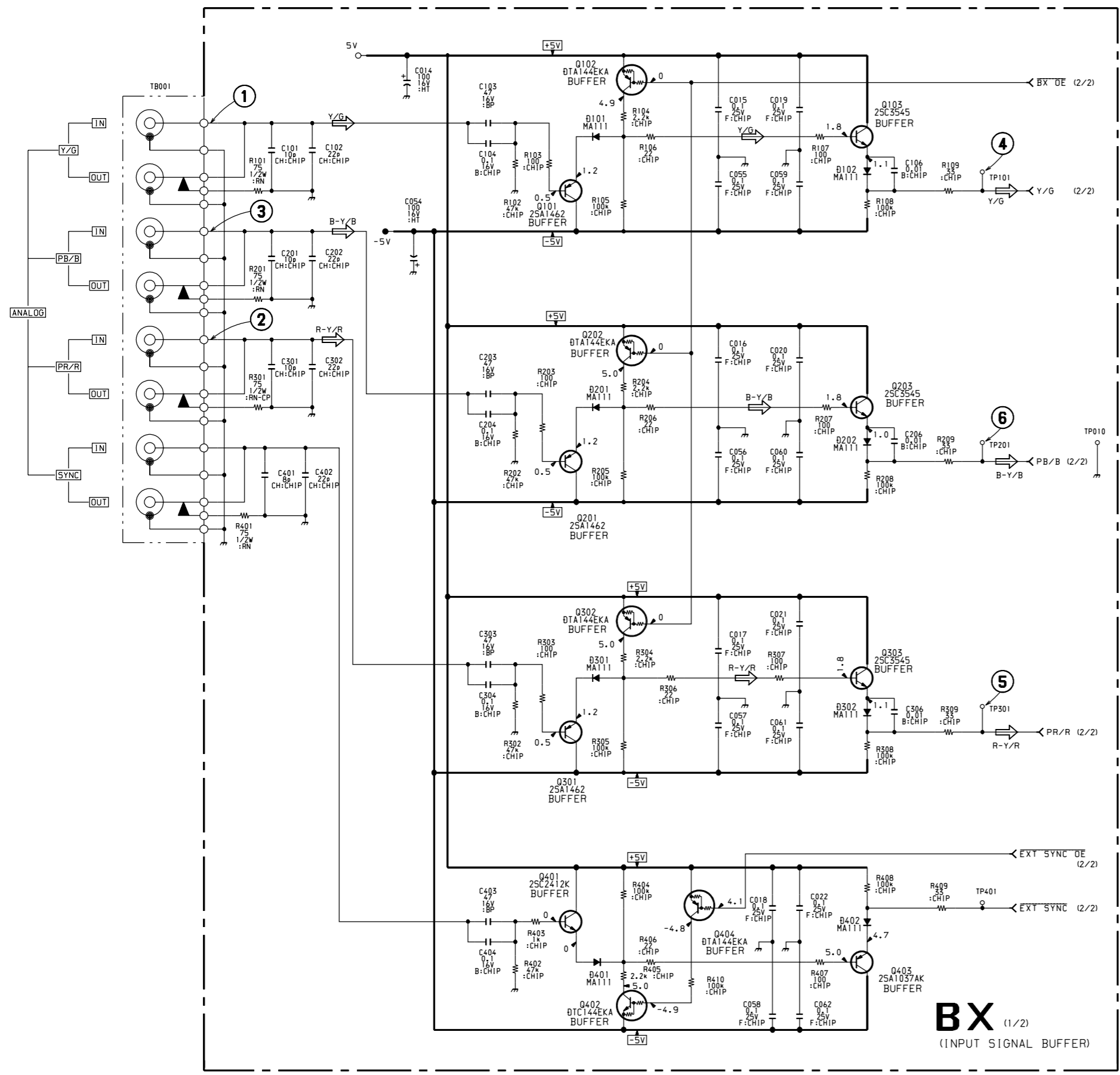

**BX** (1/2)  
(INPUT SIGNAL BUFFER)

B-SS9646-BX.-P1

**BX BOARD WAVEFORMS**

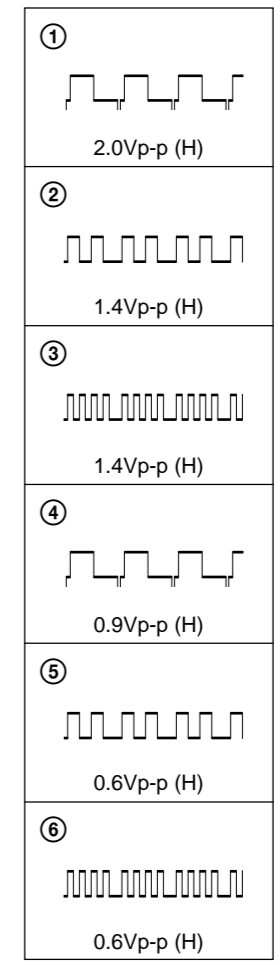

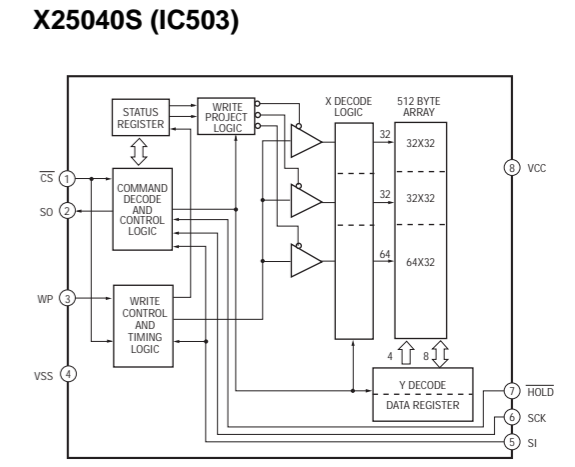
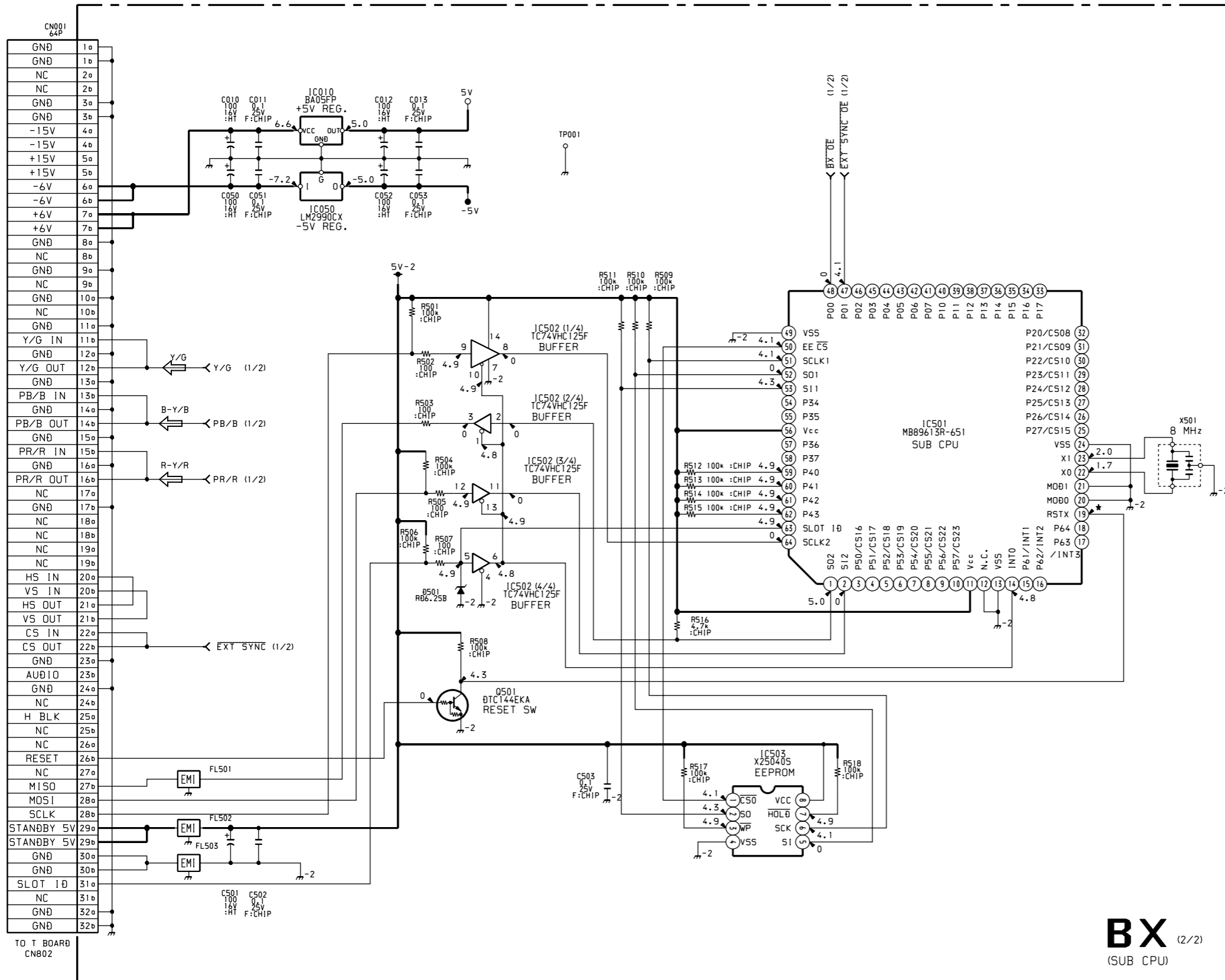

**BX** (2/2)  
(SUB CPU)

B-SS9646-BX.-P2

**B BOARD**

\* : B SIDE

D1400	C-3	Q460	* B-1	TP300	A-1
D1401	D-4	Q461	* B-1	TP301	A-1
D1402	D-3	Q462	* B-2	TP302	A-1
D1403	C-3	Q463	* C-1	TP303	B-1
D1404	* B-3	Q464	* C-2	TP304	B-2
D1405	* C-3	Q465	* B-2	TP310	A-1
D2345	* A-5	Q466	* C-1	TP1300	C-2
D2346	* B-4	Q485	* B-1	TP1301	C-2
D2347	* B-5	Q486	* C-1	TP1302	C-1
D2348	* A-5	Q487	* C-1	TP2345	A-4
D2349	* B-5	Q1300	* C-2	TP2355	B-4
D2355	* C-5	Q1301	* C-2	TP2365	C-4
D2356	* B-4	Q1302	* D-2	TP3301	A-3
D2357	* B-5	Q1303	* D-2		
D2358	* C-5	Q1304	* D-1		
D2359	* C-4	Q1305	* D-1		
D2365	* D-5	Q1320	* C-2		
D2366	* B-4	Q1321	* C-2		
D2367	* B-5	Q1322	* D-2		
D2369	* D-5	Q1323	* D-2		
D2370	* D-4	Q1340	* C-1		
D3301	* B-4	Q1341	* C-1		
D3302	* A-3	Q1342	* D-1		
D3307	* D-4	Q1343	* D-1		
D3308	* D-4	Q1400	* C-3		
D4401	* D-3	Q1401	* C-3		
		Q1402	* C-3		
		Q1410	* C-3		
		Q1411	* C-3		
		Q1412	* C-4		
		Q1413	* C-3		
		Q1414	* C-4		
		Q1420	* C-3		
		Q1421	* C-3		
		Q1422	* C-4		
		Q1423	* C-3		
		Q1424	* C-4		
		Q1430	* B-3		
		Q1431	* B-3		
		Q1432	* B-4		
		Q1433	* B-3		
		Q1434	* B-4		
		Q1460	* D-3		
		Q1461	* D-4		
		Q1462	* C-3		
		Q1463	* C-3		
		Q2300	* B-4		
		Q2301	* B-4		
		Q2302	* B-4		
		Q2303	* B-4		
		Q2315	* C-4		
		Q2316	* C-4		
		Q2317	* C-4		
		Q2318	* B-4		
		Q2330	* D-4		
		Q2331	* C-4		
		Q2332	* C-4		
		Q2333	* C-4		
		Q2345	* A-5		
		Q2346	* A-4		
		Q2355	* C-5		
		Q2356	* C-5		
		Q2365	* D-5		
		Q2366	* D-5		
		Q2375	* D-5		
		Q2376	* C-4		
		Q2377	* B-5		
		Q2380	* D-3		
		Q2381	* D-3		
		Q2382	* D-3		
		Q2383	* D-3		
		Q3301	* A-3		
		Q3302	* A-4		
		Q3303	* A-4		
		Q3304	* A-3		
		Q3305	* A-4		
		Q3306	* A-3		
		Q3307	* A-4		
		Q3308	* A-4		
		Q3309	* B-3		
		Q3310	* A-3		
		Q3311	* A-3		
		Q3312	* B-3		
		Q3313	* A-3		
		Q3314	* A-3		
		Q3315	* A-3		
		Q3316	* A-3		
		Q3317	* A-3		
		Q3318	* A-3		
		Q3319	* A-3		
		Q3402	* D-1		
Q300	A-1	Q3301	* A-3		
Q301	* A-1	Q3302	* A-4		
Q302	A-1	Q3303	* A-4		
Q303	A-1	Q3304	* A-3		
Q304	* B-1	Q3305	* A-4		
Q330	A-2	Q3306	* A-3		
Q331	* A-2	Q3307	* A-4		
Q332	A-2	Q3308	* A-4		
Q333	A-2	Q3309	* B-3		
Q334	* B-1	Q3310	* A-3		
Q365	A-2	Q3311	* A-3		
Q366	* A-2	Q3312	* B-3		
Q367	A-2	Q3313	* A-3		
Q368	A-2	Q3314	* A-3		
Q369	* B-2	Q3315	* A-3		
Q450	B-2	Q3316	* A-3		
Q451		Q3317	* A-3		
Q452	* C-2	Q3318	* A-3		
Q453	* B-1	Q3319	* A-3		

**B BOARD**

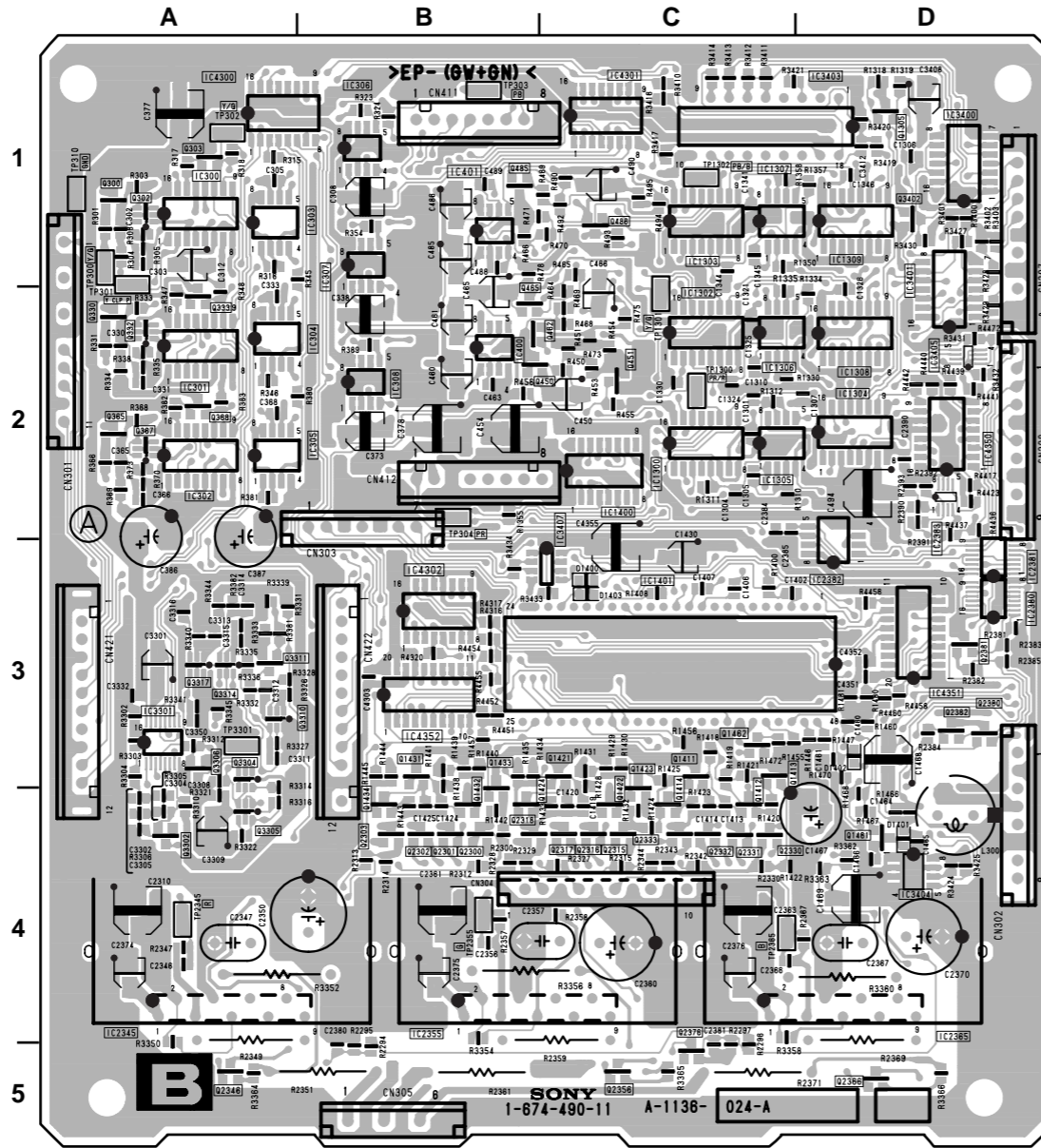

**B -A SIDE-**  
SUFFIX: -11

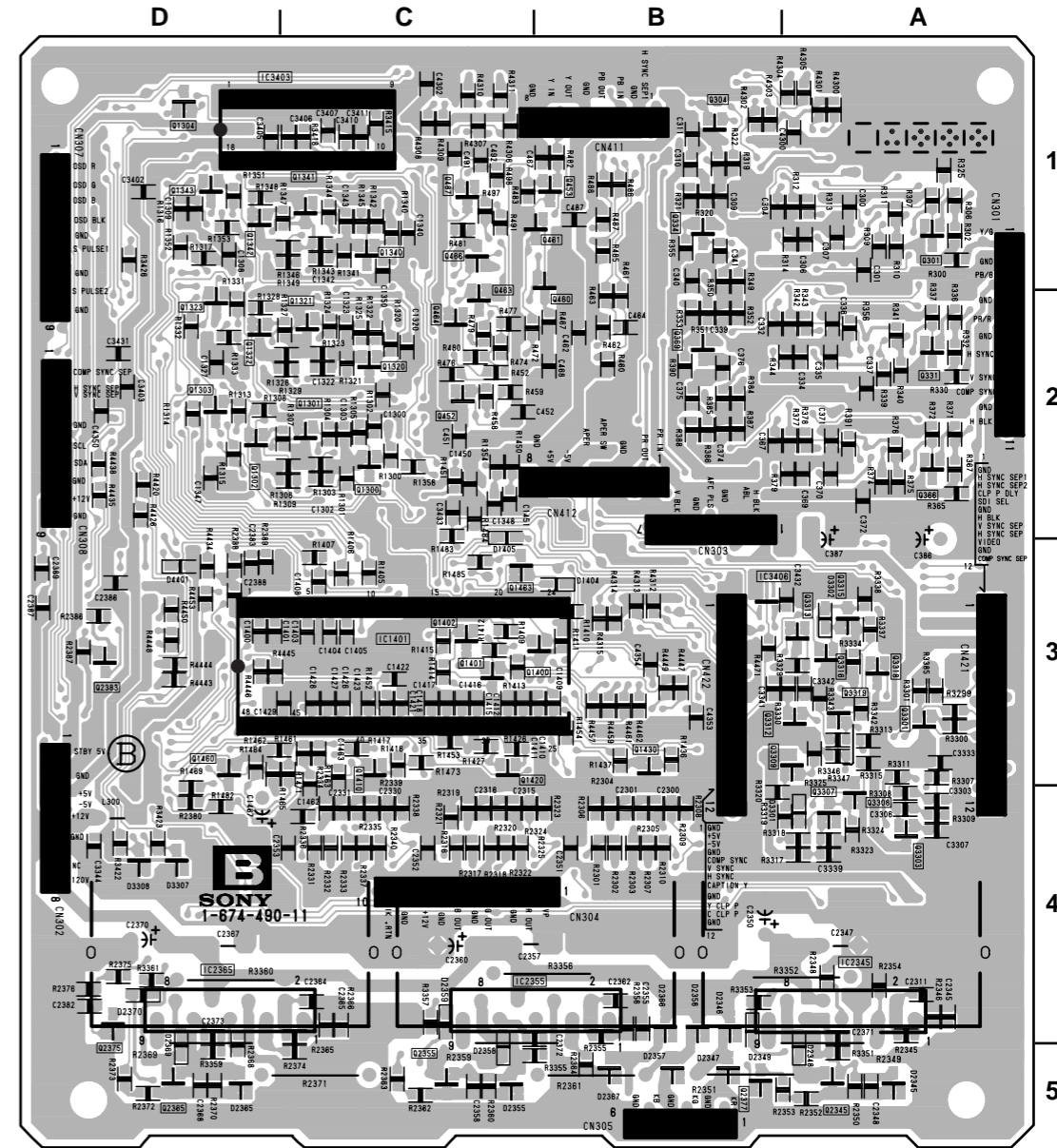

**B -B SIDE-**  
SUFFIX: -11

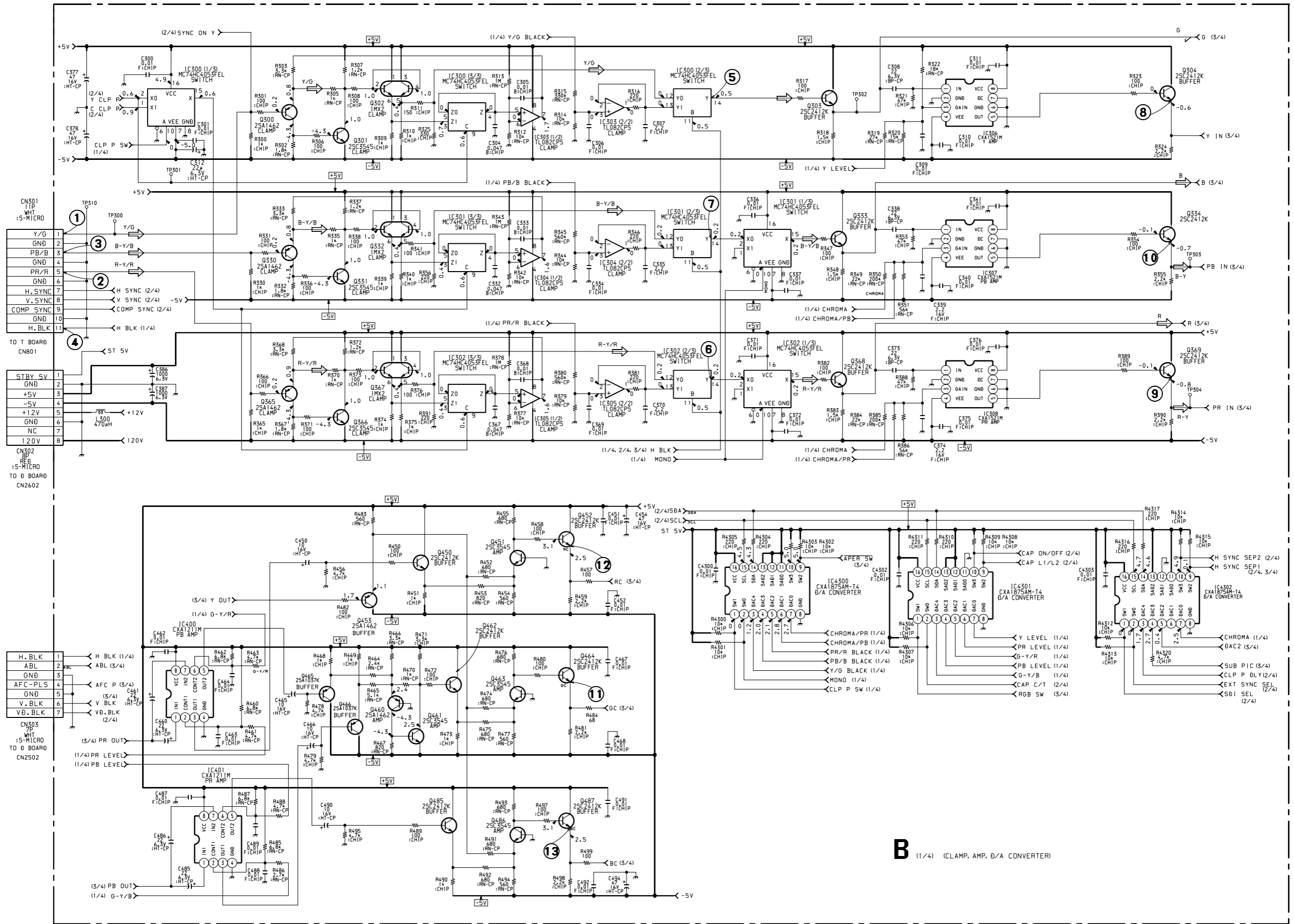

CN501  
TIP  
:S-MICRO

1	Y/G
2	GND
3	PB/B
4	GND
5	PR/R
6	GND
7	H SYNC (2/4)
8	V SYNC (2/4)
9	COMP SYNC (2/4)
10	GND
11	H BLK (1/4)

TO T BOARD  
CN801

1	STBY 5V
2	GND
3	+5V
4	-5V
5	+12V
6	GND
7	NC
8	120V

CN302  
RED  
:S-MICRO  
TO D BOARD  
CN2602

1	H BLK (1/4)
2	ABL (3/4)
3	GND
4	AFC PLS (3/4)
5	V BLK (2/4)
6	VD BLK (2/4)
7	GND

CN303  
WHT  
:S-MICRO  
TO D BOARD  
CN2502

1	(3/4) PR OUT
2	(1/4) PR LEVEL
3	(1/4) PB LEVEL





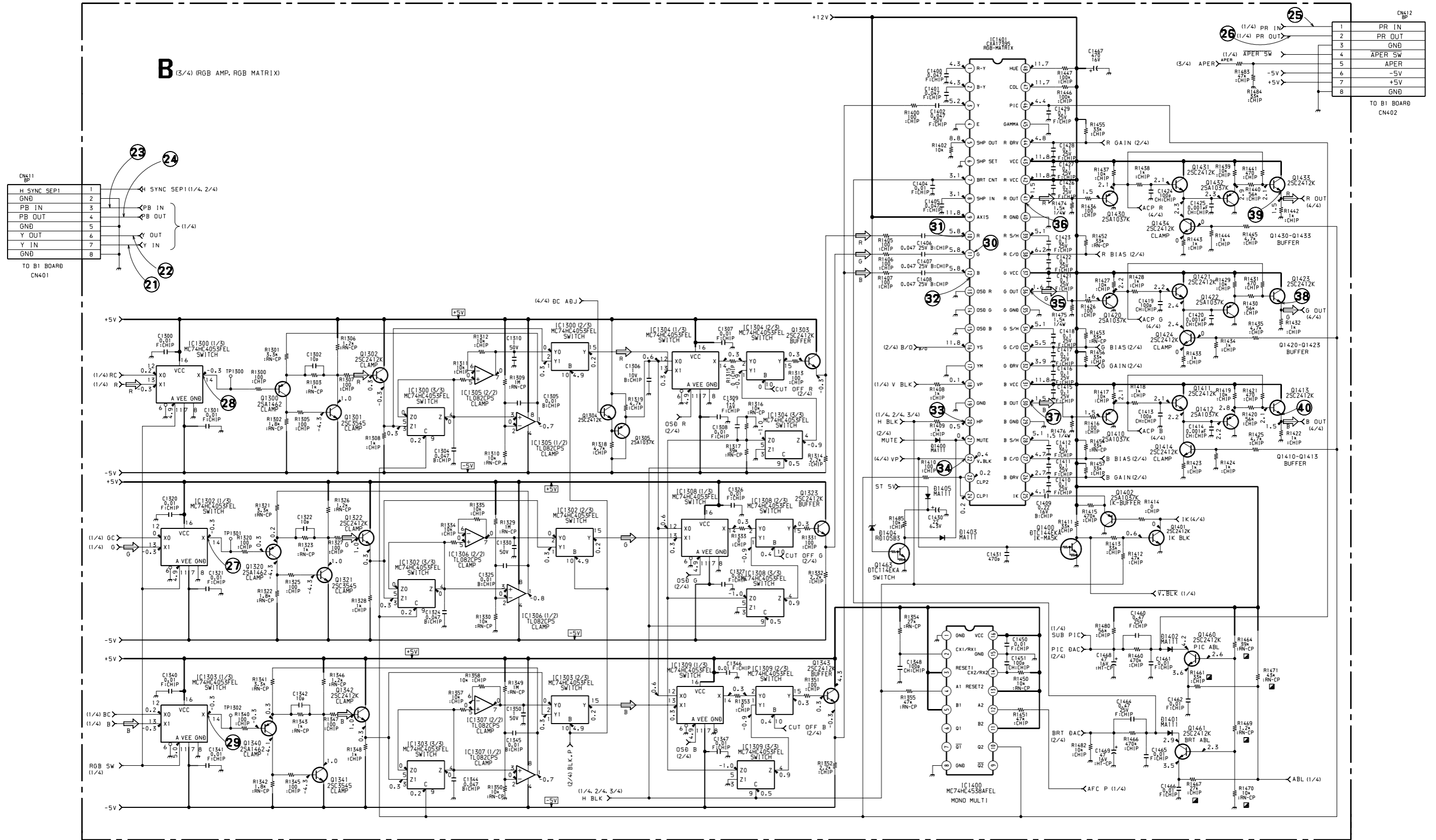

1

2

3

4

5

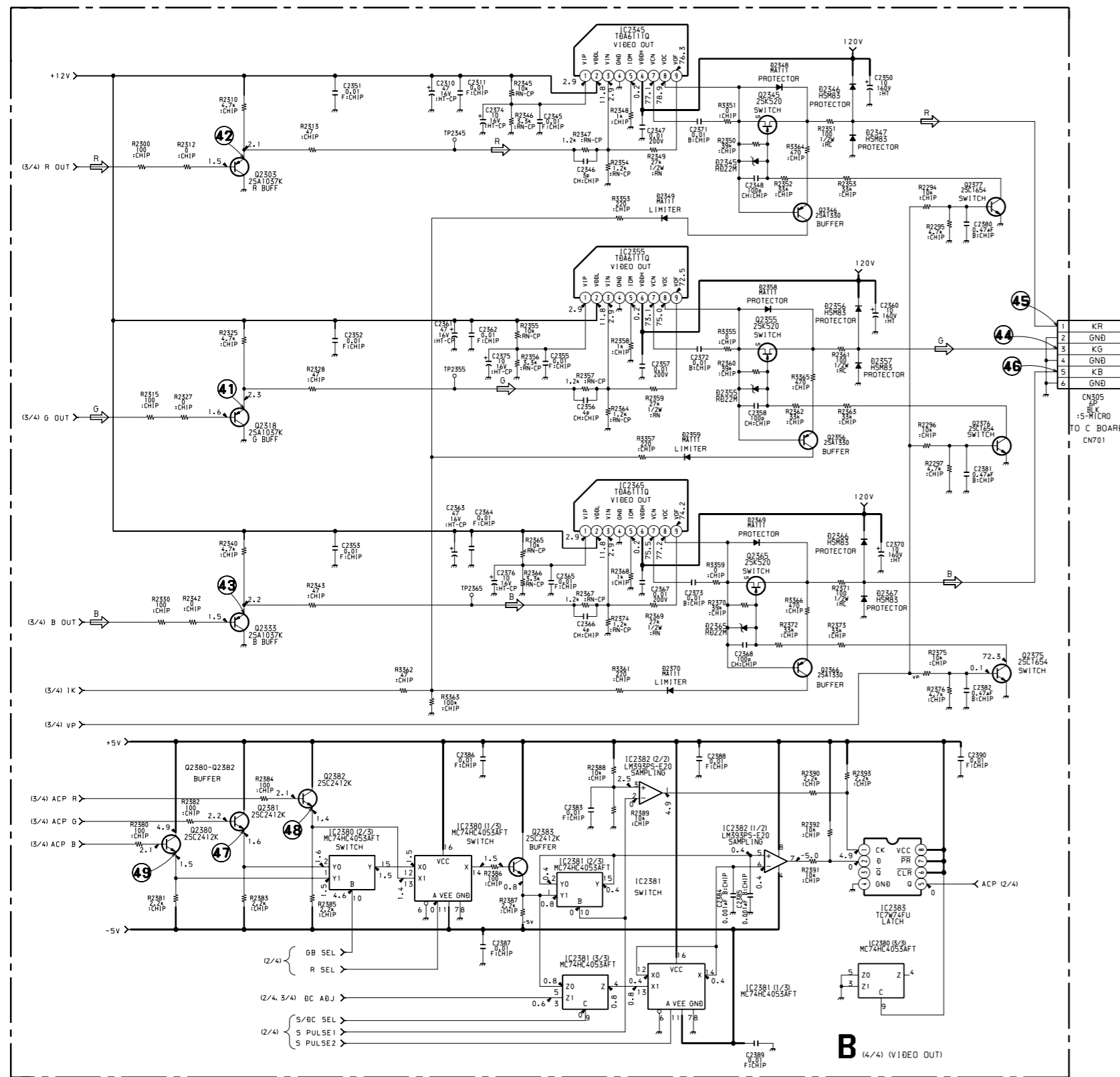

CXA1211M (IC400, 401)

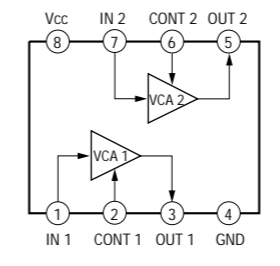

CXA1875AM-T4 (IC4300, 4301, 4302, 4350)

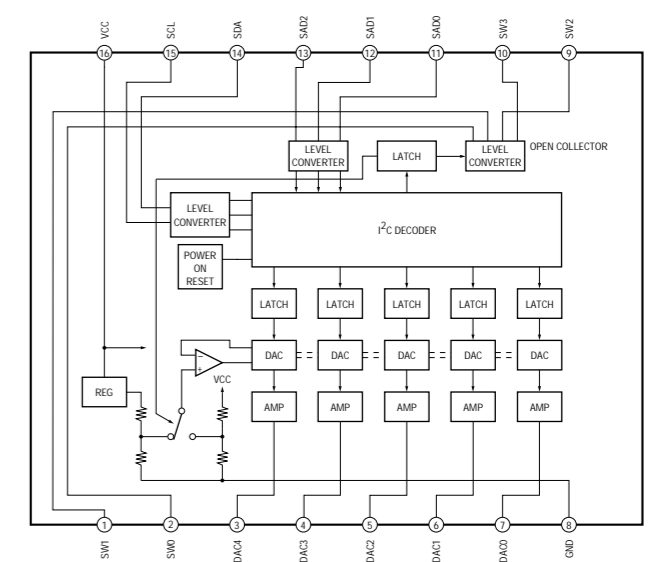

CXA1521M (IC306, 307, 308)

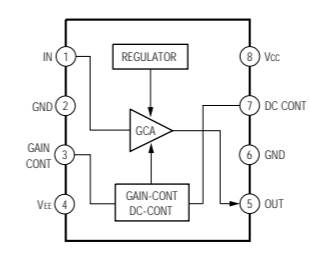

CXA1739S (IC1401)

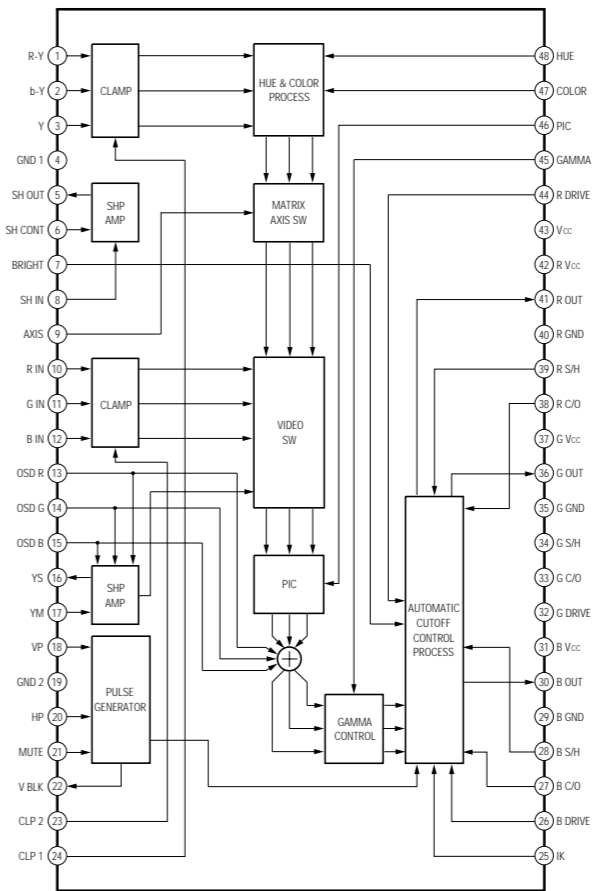

M24C02-MN6T (IC3404)

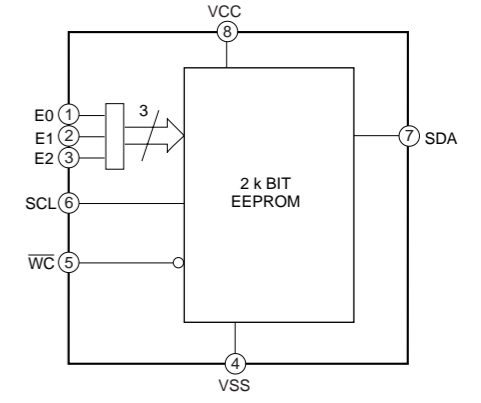

M62399FP-TE2 (IC4351, 4352)

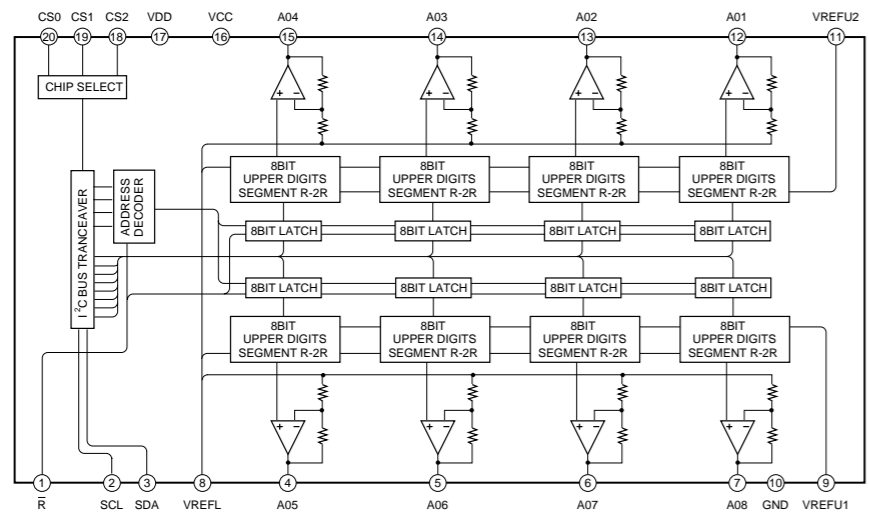

MC74HC4538AFEL (IC1400)

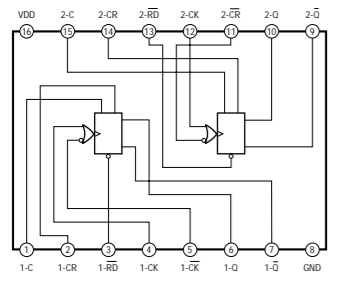

TDA6111Q (IC2345, 2355, 2365)

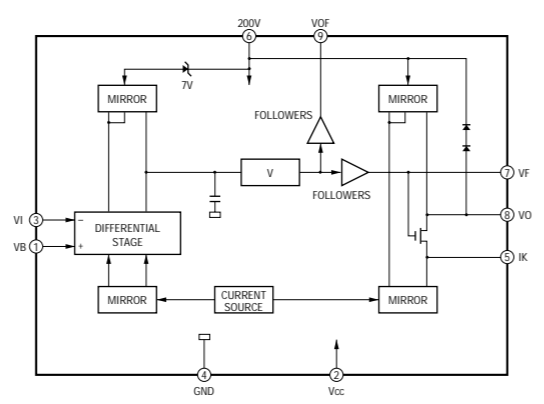

TC7W74FU (IC2383)

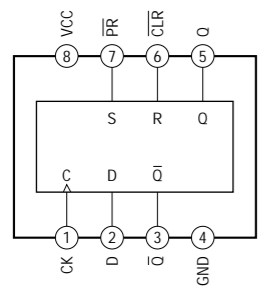

Z8622812PSC (IC3403)

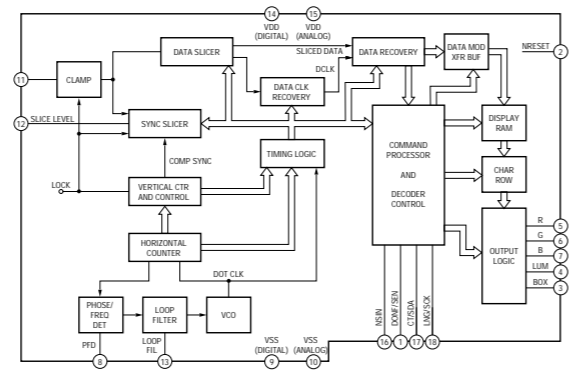

B BOARD WAVEFORMS

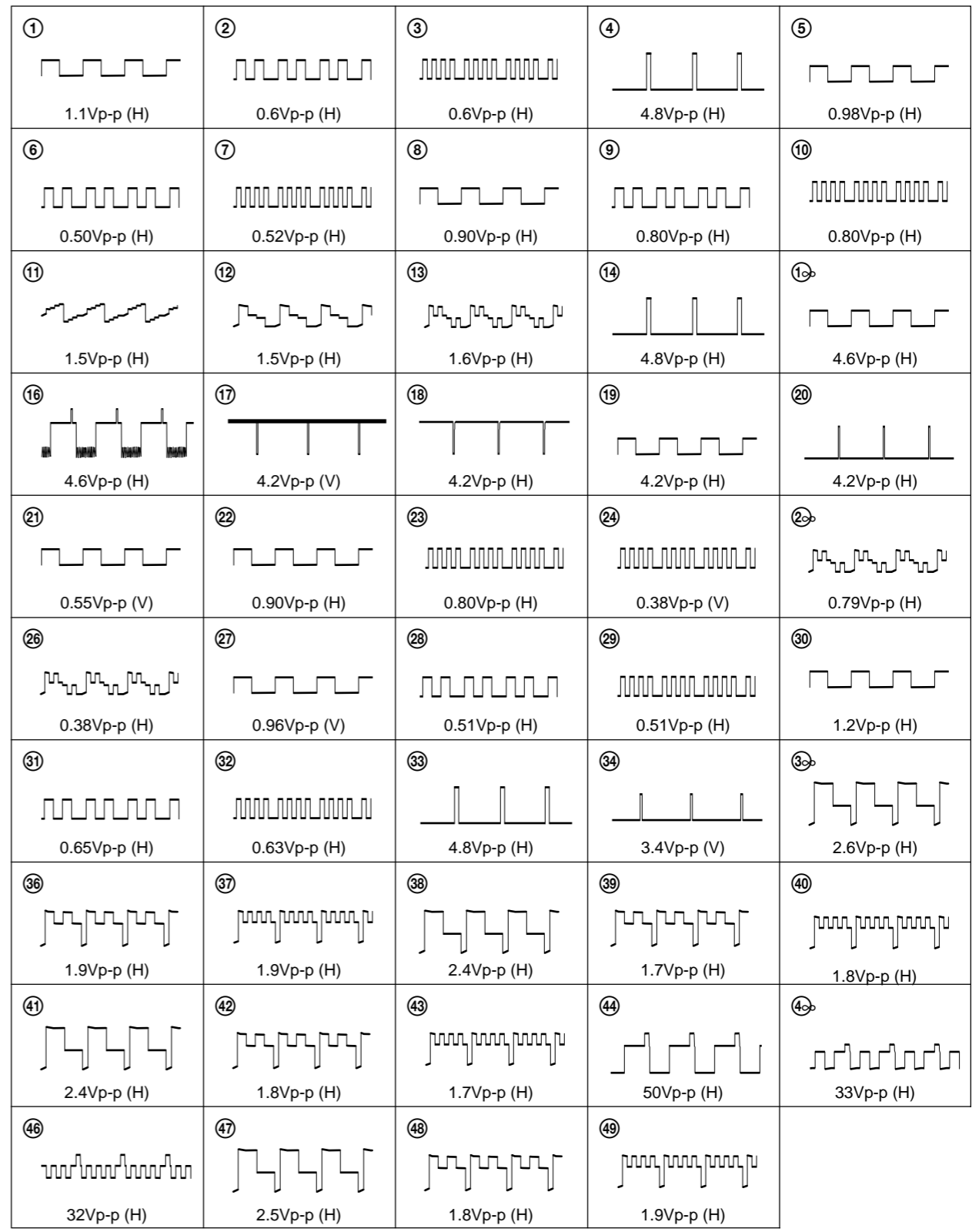

**B1**  
(Y/R-Y/B-Y AMP. SWITCH)

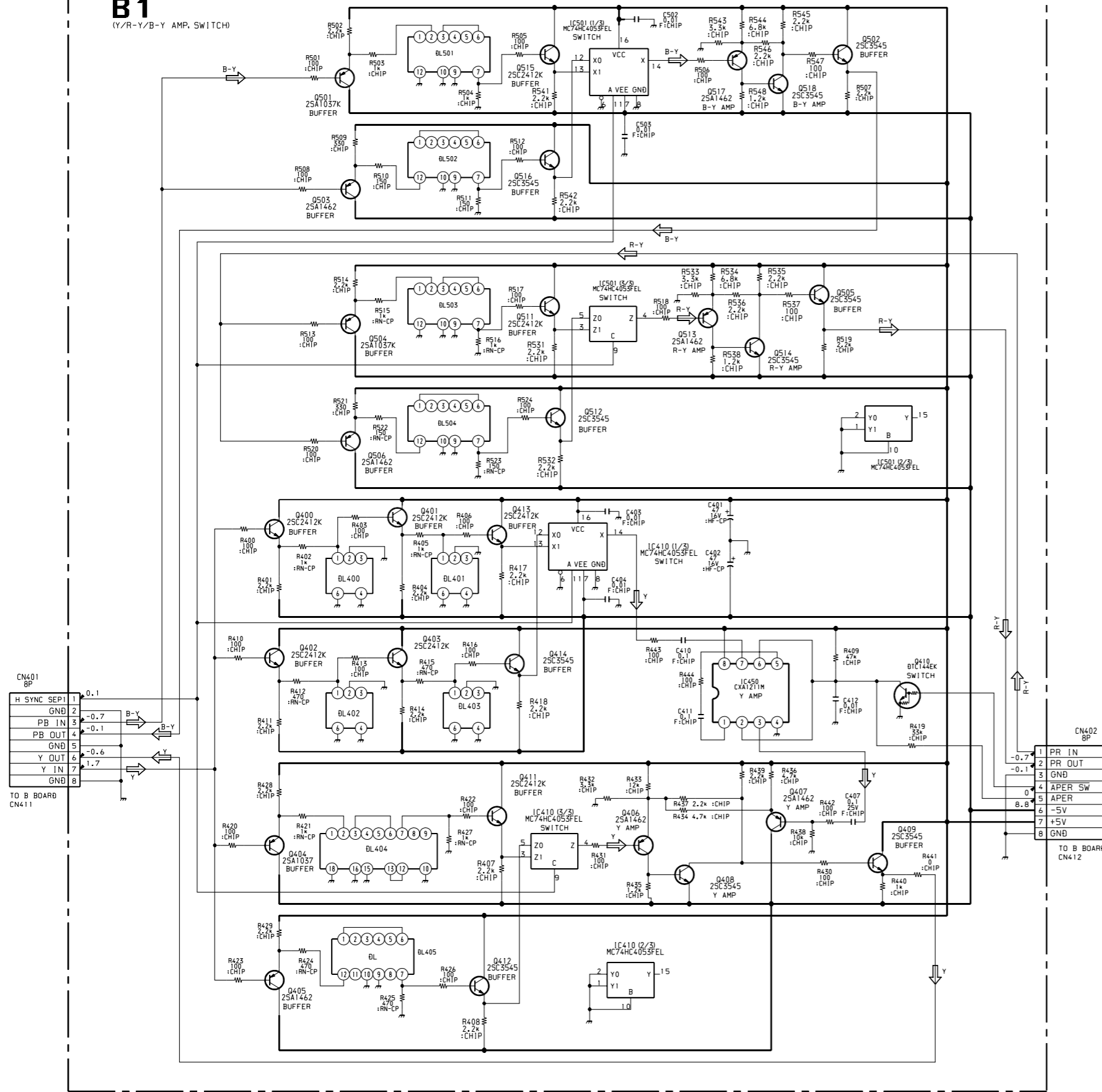

**CXA1211M (IC450)**

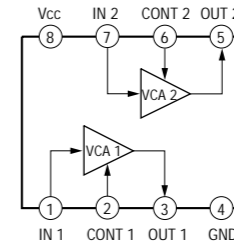

**B1 BOARD**

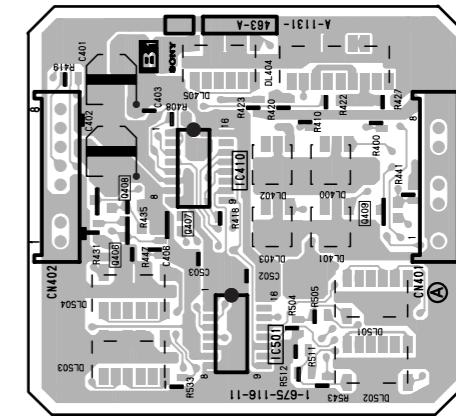

**B1 -A SIDE-**  
SUFFIX: -11

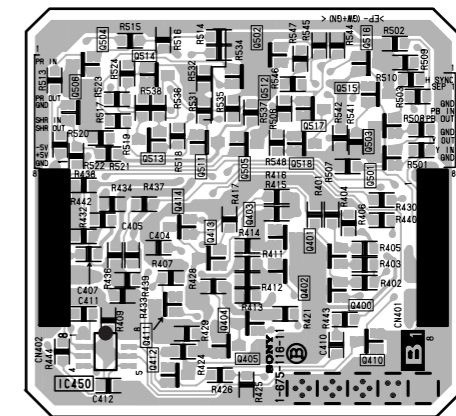

**B1 -B SIDE-**  
SUFFIX: -11

B-5V9660UC-B1.



**G BOARD**

\* : B-SIDE

D2501	F-6	IC506	B-1
D2502	G-7	IC507	C-1
D2503	F-6	IC508	C-2
D2504	J-5	IC509	B-2
D2506	G-7	IC510	E-1
D2507	H-6	IC512	E-1
D2508	E-7	IC514	K-2
D2509	E-7	IC515	E-1
D2510	H-7	IC516	D-1
D2511	H-7	IC517	K-1
D2512	J-6	IC519	F-2
D2513	K-5	IC520	* G-2
D2514	H-5	IC522	B-1
D2515	* E-6	IC523	* J-2
D2520	* J-5	IC524	B-2
D501	* E-2	IC526	B-1
D502	* E-2	IC527	B-2
D503	* E-2	IC528	D-1
D504	* E-2	IC529	A-2
D505	E-2	IC601	D-7
D506	* J-3	IC602	C-5
D507	* J-2	IC606	F-3
D508	* J-2	IC607	F-3
D509	* J-2	IC608	D-3
D510	* J-2	IC609	E-2
D511	* J-2	IC610	D-3
D512	* J-2		
D513	J-3	Q2501	G-6
D514	* K-4	Q2502	G-6
D515	* F-1	Q2503	G-7
D516	H-4	Q2504	E-6
D517	* F-2	Q2505	G-6
D518	J-4	Q2508	J-7
D519	J-4	Q2511	J-5
D520	H-3	Q2513	J-5
D524	G-2	Q2514	G-5
D525	* G-3	Q2515	* G-5
D529	* C-1	Q2518	G-5
D530	E-1	Q2519	* G-5
D531	* C-2	Q501	B-1
D532	* C-2	Q504	E-2
D533	* B-2	Q505	F-1
D534	* D-1	Q506	* J-4
D535	* F-2	Q507	* K-4
D536	* C-1	Q508	* F-1
D537	* F-2	Q509	* F-1
D538	* C-1	Q510	F-1
D539	* C-2	Q511	F-1
D540	* B-1	Q512	F-1
D601	* B-3	Q513	K-4
D602	B-4	Q514	H-4
D603	* C-3	Q517	G-3
D604	C-3	Q518	G-3
D605	C-4	Q520	* C-1
D607	* C-4	Q521	* D-2
D608	D-7	Q523	E-2
D609	* D-4	Q524	* C-1
D612	* C-4	Q525	* D-1
D614	* D-5	Q529	B-2
D617	* D-5	Q530	B-2
D619	* D-4	Q531	B-2
D620	* D-4	Q532	* E-1
D622	F-5	Q533	* F-2
D623	F-5	Q534	* E-1
D624	G-4	Q535	* C-1
D625	D-3	Q536	B-2
D626	F-4	Q601	* A-2
D627	F-2	Q602	C-4
D633	* C-3	Q603	* C-3
D634	A-2	Q604	* C-3
D635	C-6	Q605	D-4
D636	* D-5	Q608	D-4
D637	F-4	Q609	* D-4
D638	* E-2	Q611	* F-2
D639	* F-2	Q612	* F-2
D640	* F-2	Q613	* F-2
		Q614	G-4
IC2501	* F-6	Q615	* D-3
IC2502	* E-6	Q616	* F-2
IC2503	K-5	Q617	* F-2
IC2504	E-6	Q618	* D-2
IC501	B-1	Q619	* A-2
IC502	D-1	Q620	* F-2
IC503	B-1	Q621	* F-2
		Q622	* E-2

**G BOARD**

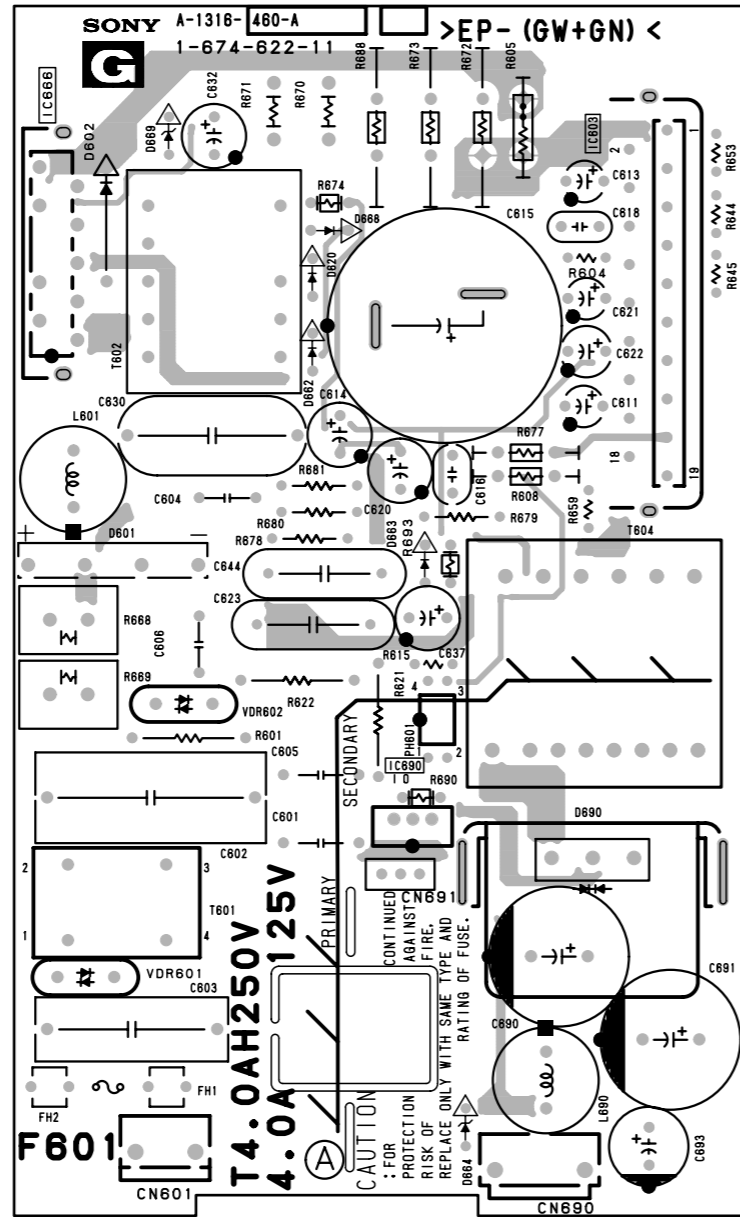

**G -A SIDE-**  
SUFFIX: -11

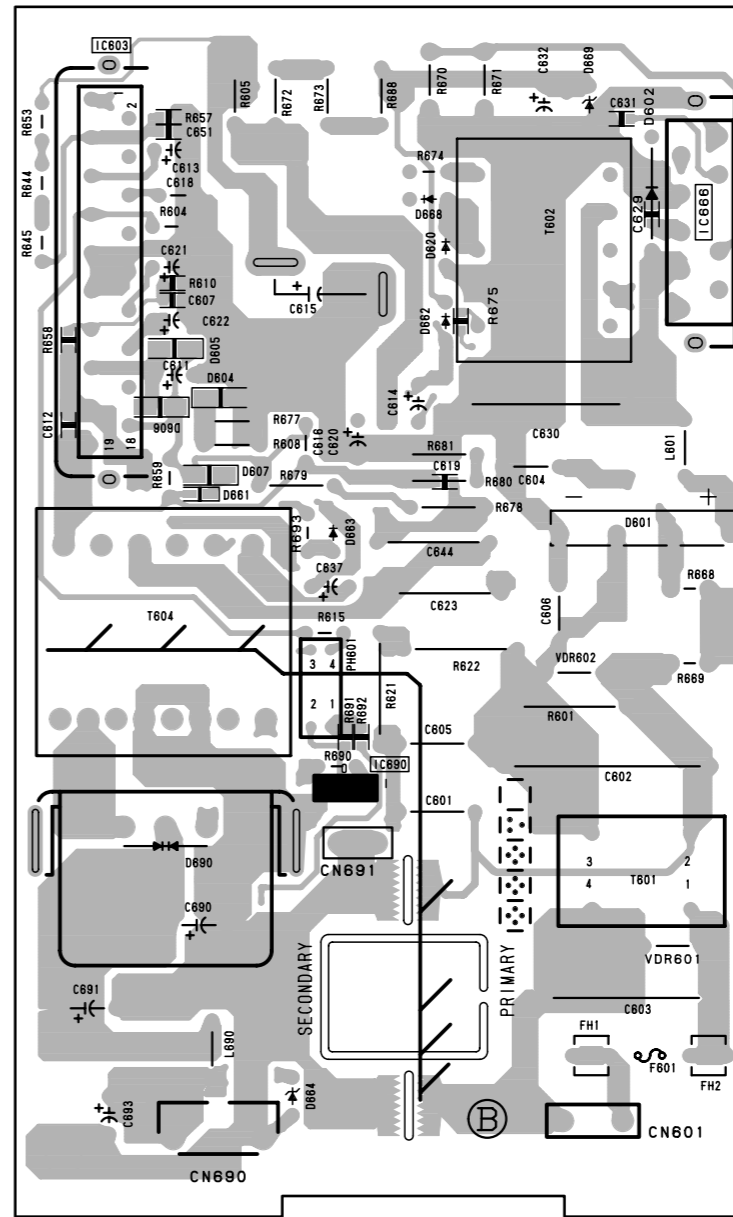

**G -B SIDE-**  
SUFFIX: -11

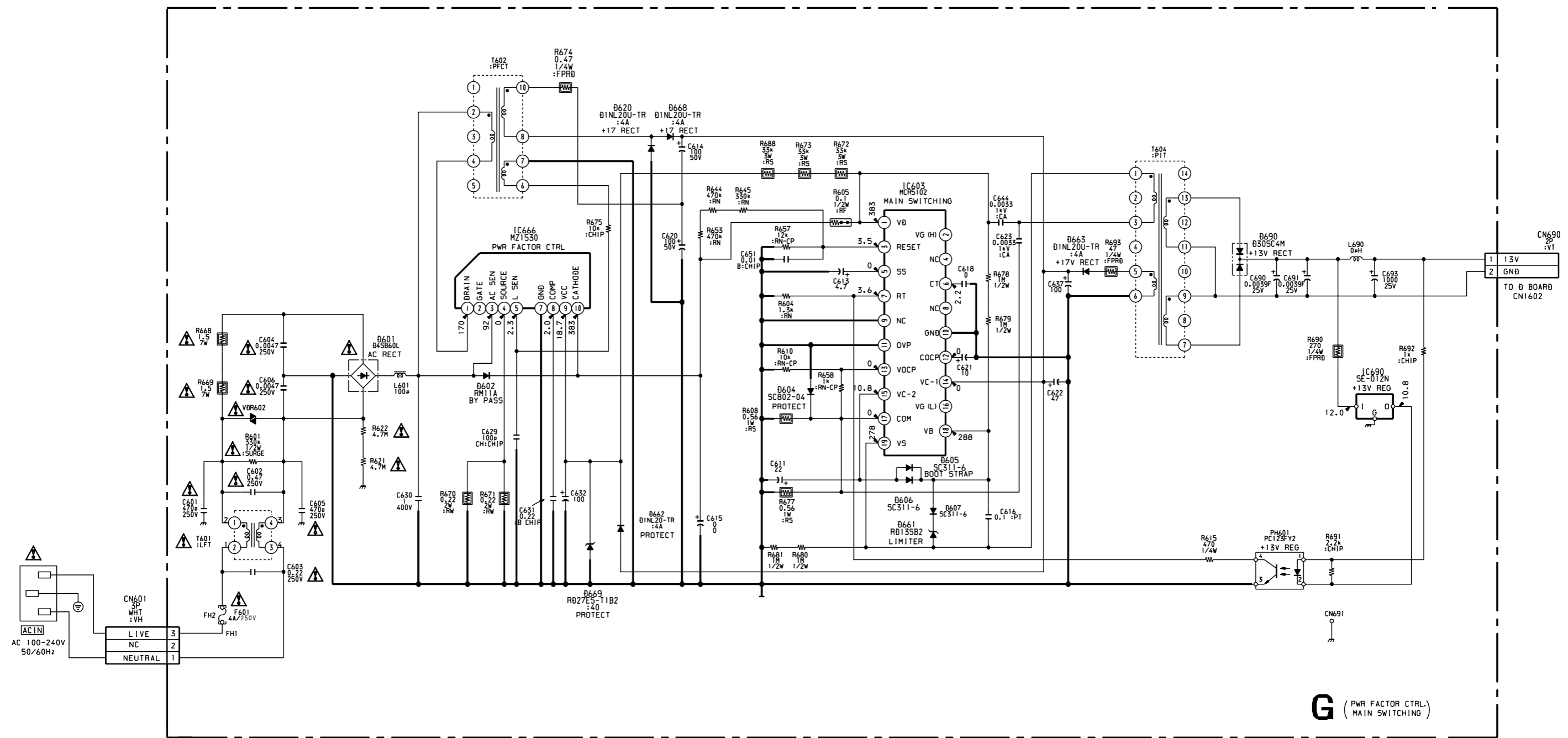

G (PWR FACTOR CTRL.) MAIN SWITCHING

B-SV9660UC-G..

1

2

3

4

5

MCR5102 (IC603)

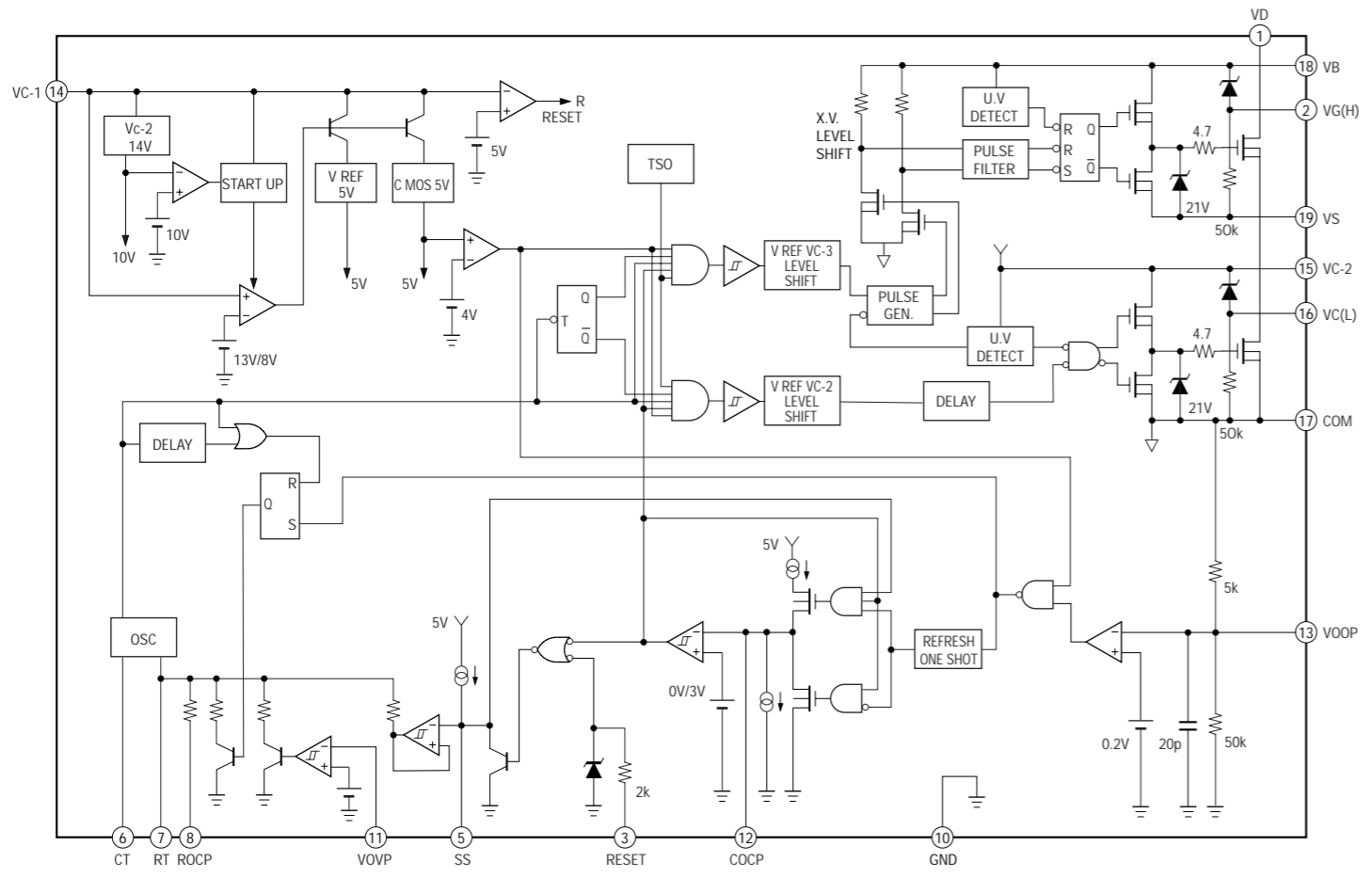

MZ1530 (IC666)

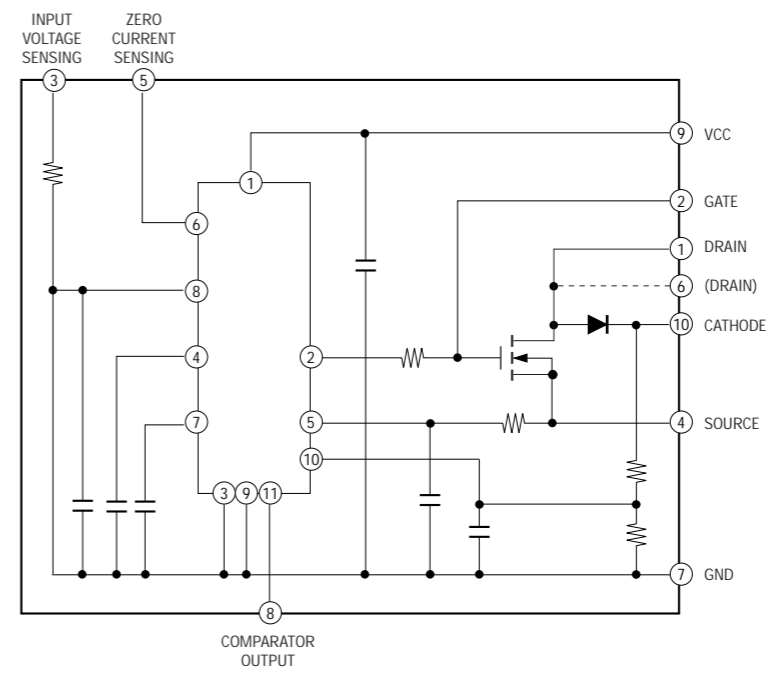



C BOARD

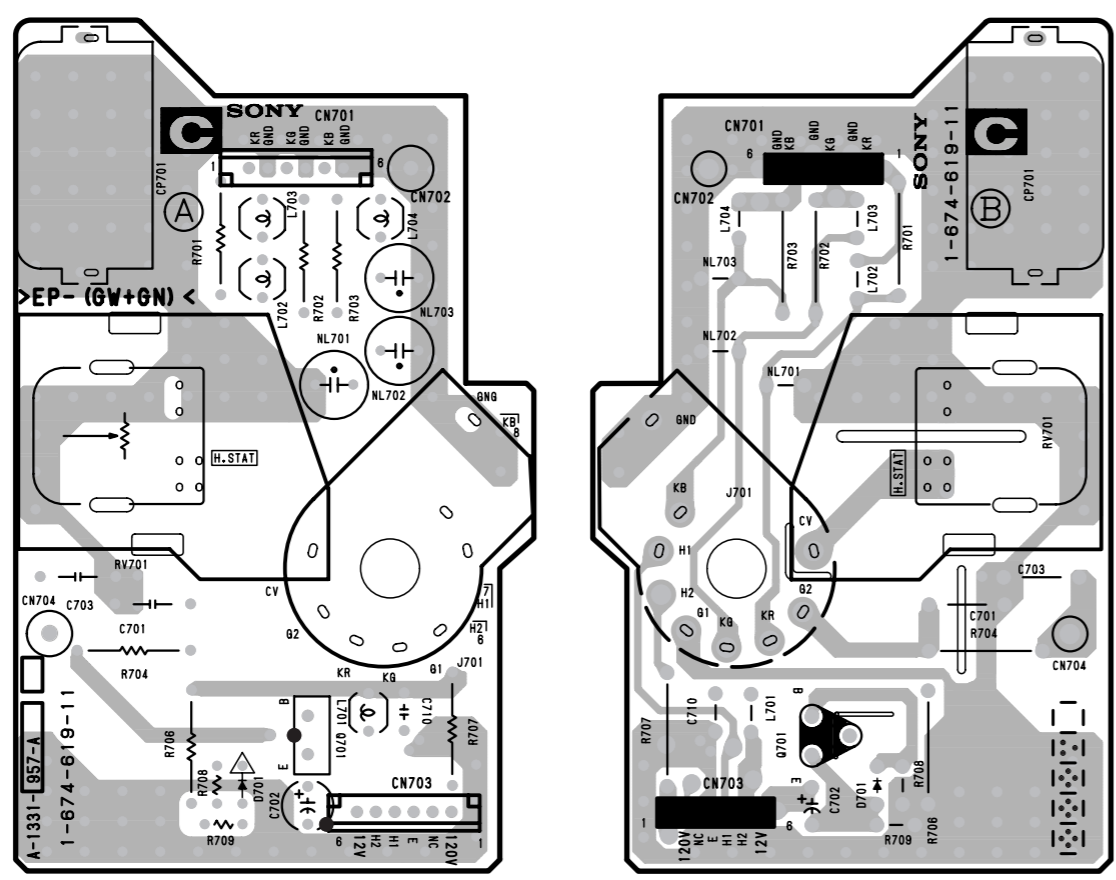

C -A SIDE-  
SUFFIX: -11

C -B SIDE-  
SUFFIX: -11

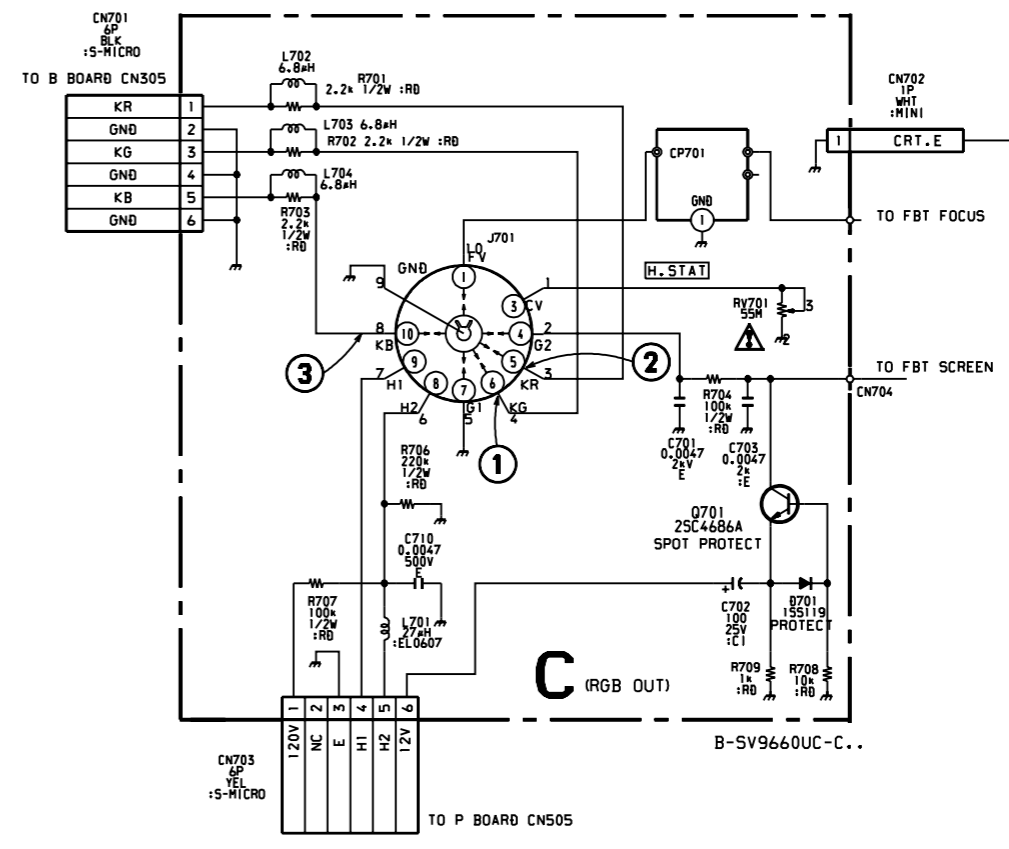
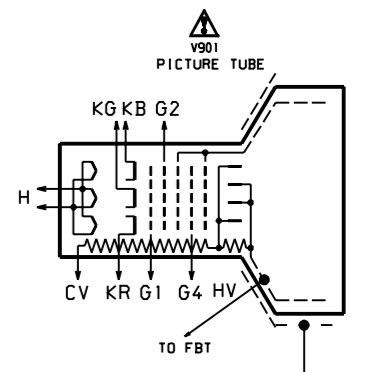

C BOARD WAVEFORMS

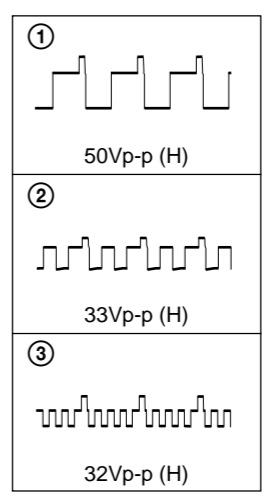

1

2

3

4

5

D BOARD

D BOARD

\*: B SIDE

D1601	B-1	Q1601	A-1
D1602	A-1	Q1602	A-1
D1603	A-1	Q1603	A-1
D1604	A-1	Q1604	B-1
D1605	B-1	Q1605	B-1
D1606	B-1	Q1608	2-D
D1607	A-1	Q1609	2-D
D1608	A-1	Q1610	2-D
D1609	* A-1	Q1611	C-1
D1610	C-1	Q1612	B-2
D1611	* B-2	Q1613	C-2
D2501	* A-7	Q1614	* C-2
D2504	* A-6	Q1617	D-3
D2505	A-6	Q2502	* A-7
D2506	* B-6	Q2503	* C-7
D2507	* B-6	Q2507	* A-6
D2509	* A-4	Q2508	* A-6
D2511	* B-6	Q2509	A-6
D2512	* B-6	Q2510	* B-6
D2513	* C-6	Q2511	* A-6
D2515	* C-5	Q2512	* B-6
D2516	* B-6	Q2513	* B-6
D2517	* B-7	Q2514	A-5
D2518	* B-7	Q2516	A-4
D2519	* B-5	Q2517	* C-6
D2520	* B-7	Q2519	* B-3
D2521	* B-7	Q2520	* B-4
D2522	* B-7	Q2521	* C-5
D2523	A-7	Q2522	* B-3
D2524	* B-7	Q2523	* C-3
D2525	* C-3	Q2524	B-7
D2526	* B-3	Q2525	* B-7
D2527	* C-6	Q2526	* B-7
D2528	C-7	Q2527	* D-6
D2529	* D-7	Q2528	* C-6
D2530	* B-7	Q2529	* D-6
D2532	* B-6	Q2530	* D-6
D2533	C-5	Q2531	* C-7
D2601	* B-2	Q2532	C-7
D2602	B-1	Q2533	C-7
D2604	* B-2	Q2534	C-7
D2605	B-1	Q2535	* A-6
D3601	* A-2	Q2601	D-3
D3603	* A-3	Q2602	C-3
D3604	* A-2	Q2603	C-3
D3605	* A-3	Q2604	D-3
D3606	* A-3	Q2605	B-2
D3607	* A-2	Q2606	B-2
D3608	A-2	Q2607	* B-1
D3609	A-2	Q2609	D-2
		Q2610	B-2
		Q2611	B-2
		Q2612	* B-1
		Q3601	C-3
		Q3602	C-3
		Q3603	C-3
		Q3604	C-3
		Q3605	A-2
		Q3606	A-2
		Q3607	* A-1
		Q3609	* A-2
		Q3610	C-2
		Q3611	A-2
		Q3612	B-2
		Q3613	* B-1
IC1601	C-2		
IC1602	C-2		
IC2501	D-7		
IC2502	D-6		
IC2503	C-6		
IC2504	A-7		
IC2505	D-7		
IC2506	* C-7		
IC2507	A-4		
IC2508	B-6		
IC2509	* C-7		
IC2510	* C-7		
IC2512	* D-7		
IC2513	* C-7		
IC2514	B-5		
IC2515	B-5		
IC2516	D-7		
IC2517	D-7		
IC2518	A-4		
IC2519	* C-7		
IC2521	B-7		
IC2522	C-7		
IC2523	D-7		
IC2601	D-3		
IC2602	C-4		
IC2603	C-4		
IC3601	C-3		

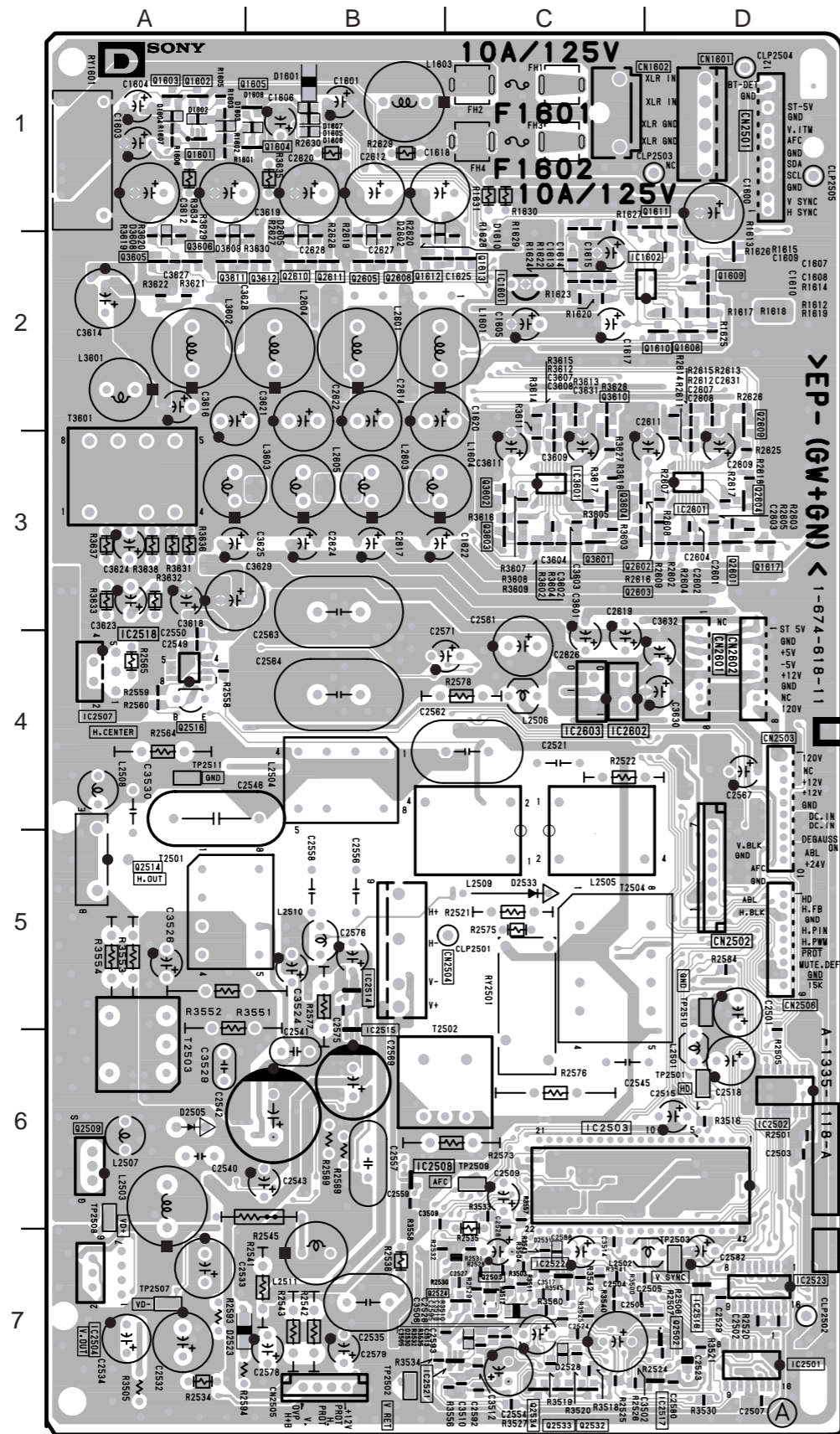

D -A SIDE-  
SUFFIX: -11

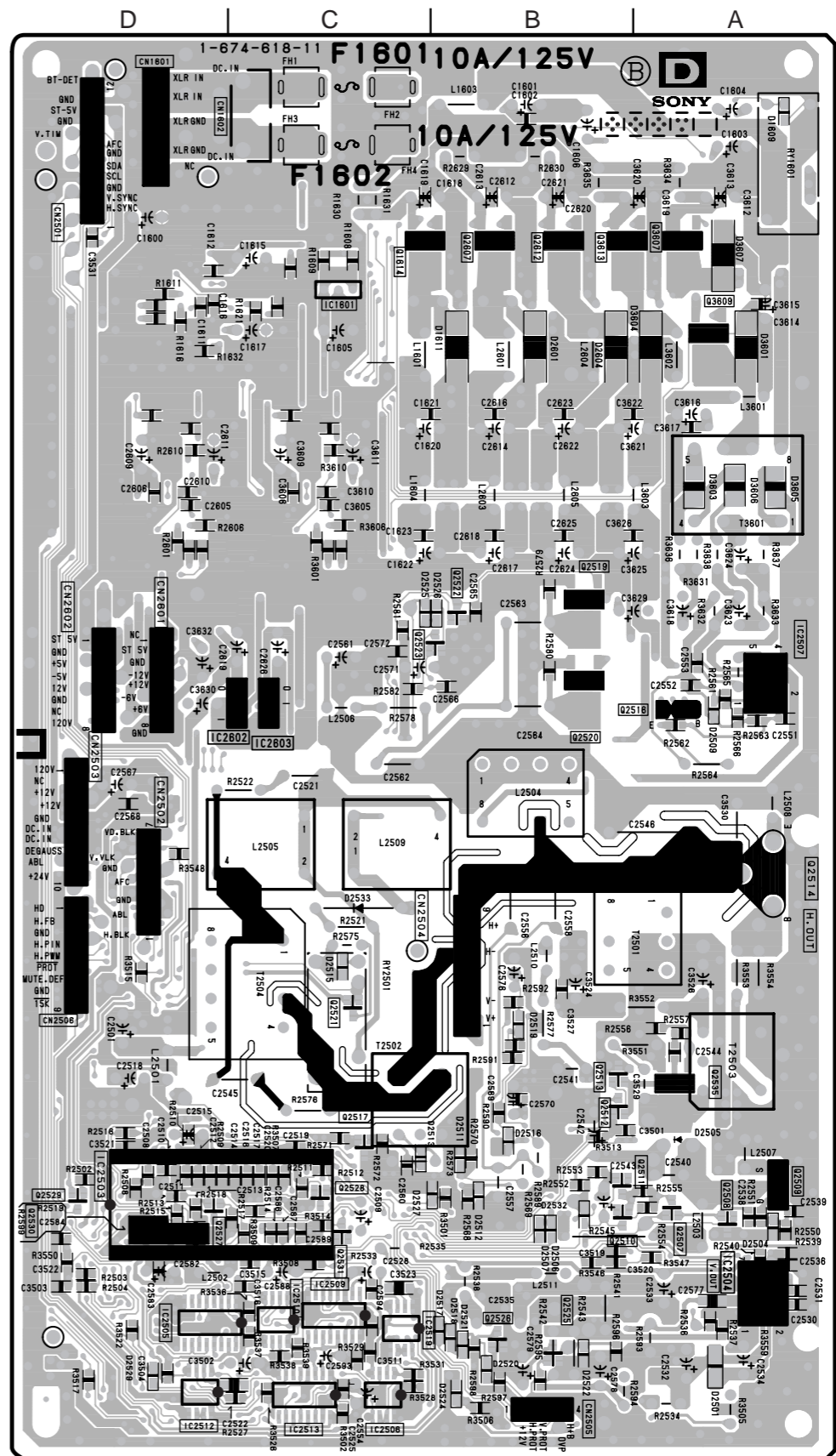

D -B SIDE-  
SUFFIX: -11

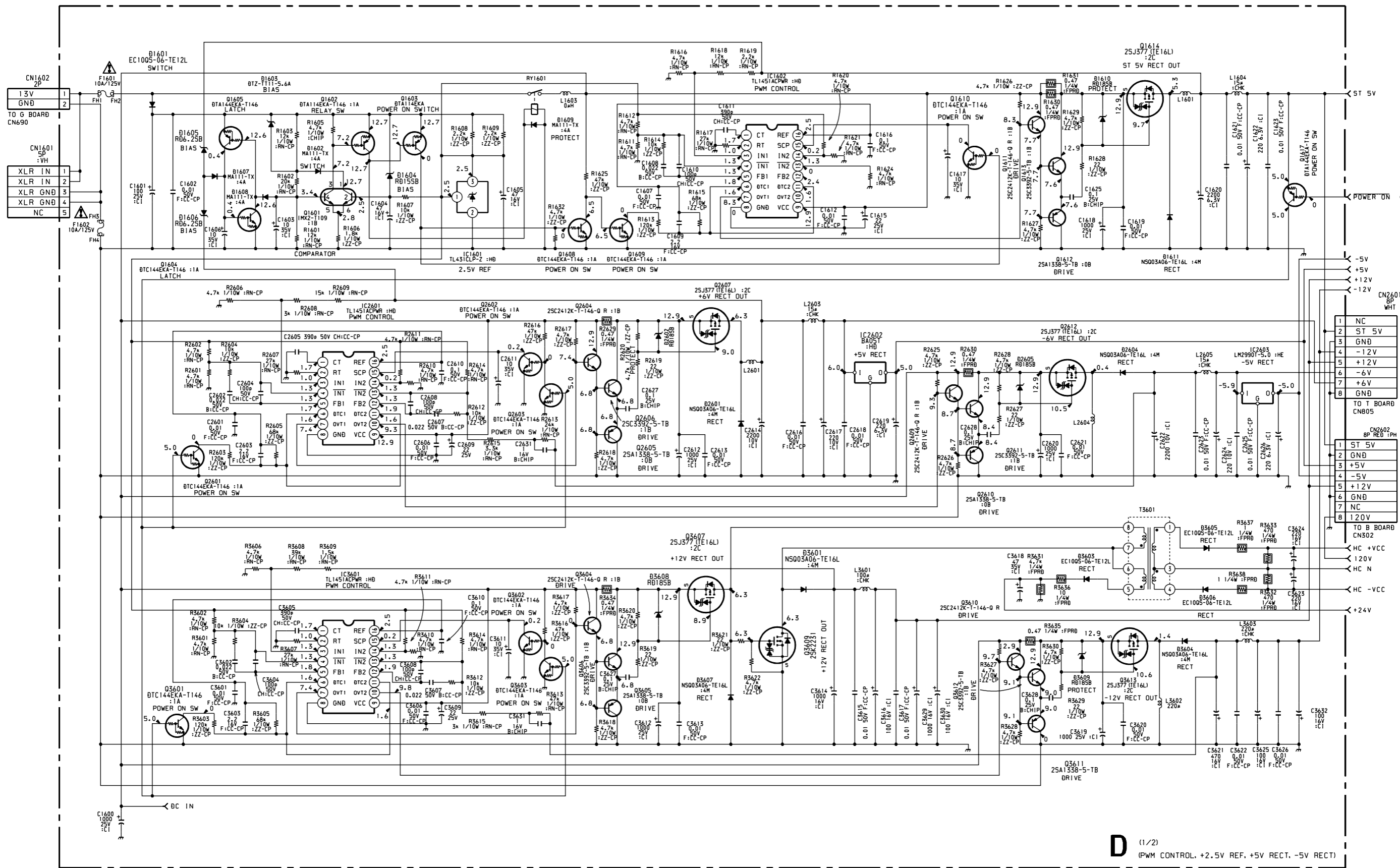

D (1/2) (PWM CONTROL, +2.5V REF, +5V RECT, -5V RECT)

B-SV9660UC-B...-P1

1

2

3

4

5

1

2

3

4

5

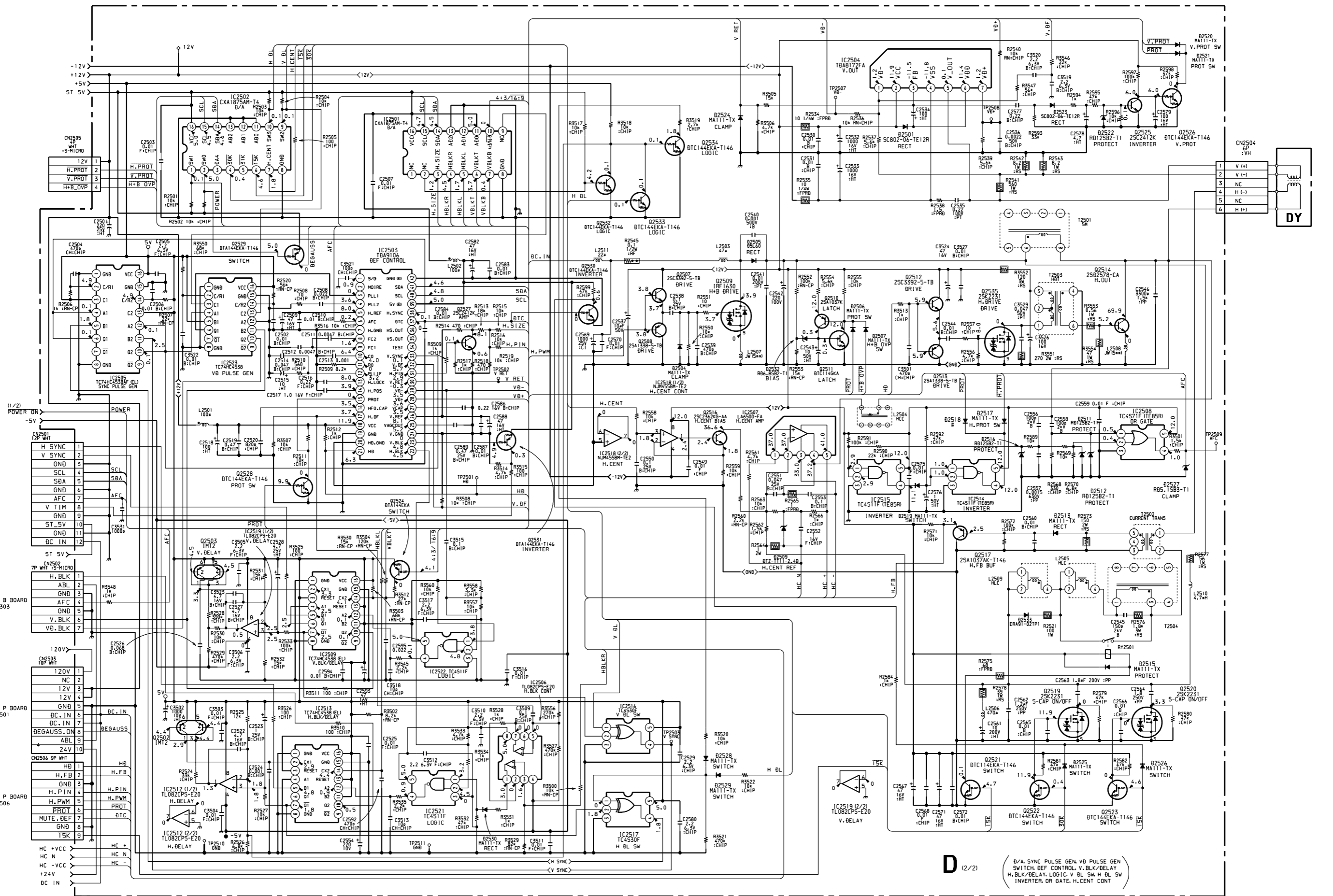

**D** (2/2)

(B/A, SYNC PULSE GEN, VB PULSE GEN)  
 SWITCH DEF CONTROL, V.BLK/DELAY  
 H.BLK/DELAY, LOGIC, V.DL SW, H.DL SW  
 INVERTER, OR GATE, H.CENT CONT

CXA1875AM-T4 (IC2501, 2502)

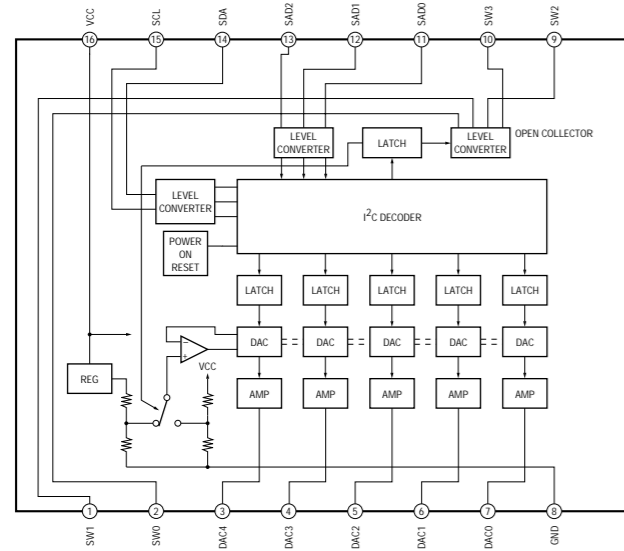

TDA8172FA (IC2504)

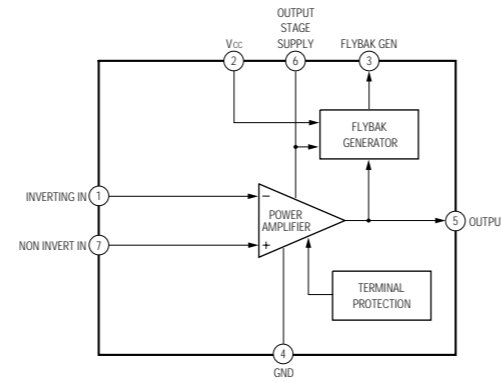

TL1451ACPWR (IC1602, 2601, 3601)

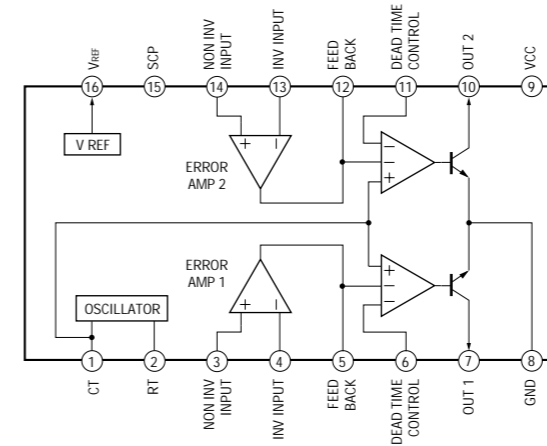

TC74HC4538AF(EL) (IC2505, 2509, 2513, 2523)

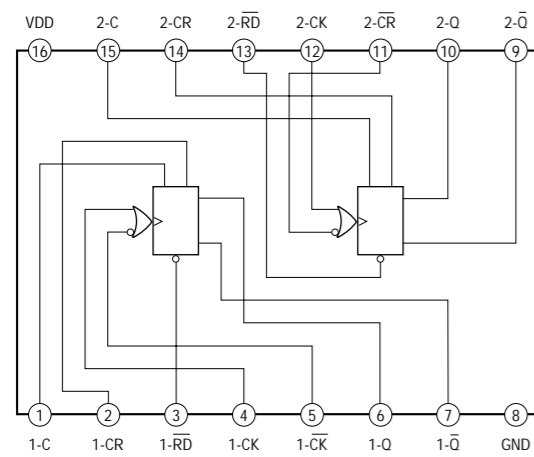

TDA9106 (IC2503)

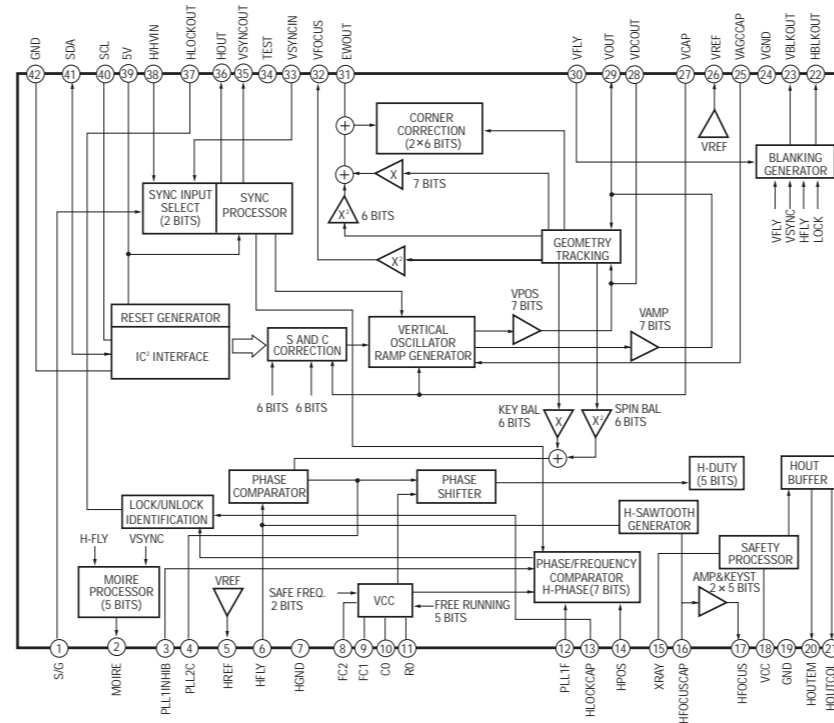

MA BOARD

[MA BOARD]

\* : B SIDE

D101	* C-4
D102	** C-4
D103	** B-4
D104	** B-4
D105	* A-5
D106	** A-5
D107	** A-5
D108	* A-5
D109	* C-4
IC101	* B-1
IC102	* C-4
IC103	** B-4
IC104	** A-4
IC106	B-2
IC107	* A-3
IC108	* A-3
IC109	* A-3
IC110	* C-3
IC111	* A-4
IC112	B-3
IC113	A-4
Q102	* A-4
Q103	* B-1
Q104	C-1
Q105	* B-1
Q106	C-1
TP101	B-1
TP102	B-1
TP103	B-1
TP104	B-1
TP105	B-4
TP106	B-4
TP107	B-4
TP108	B-1
TP109	C-5
TP110	C-2
TP111	B-4
TP112	A-2
TP113	A-2
TP114	A-5
TP115	* A-5
TP116	A-4
TP117	B-4

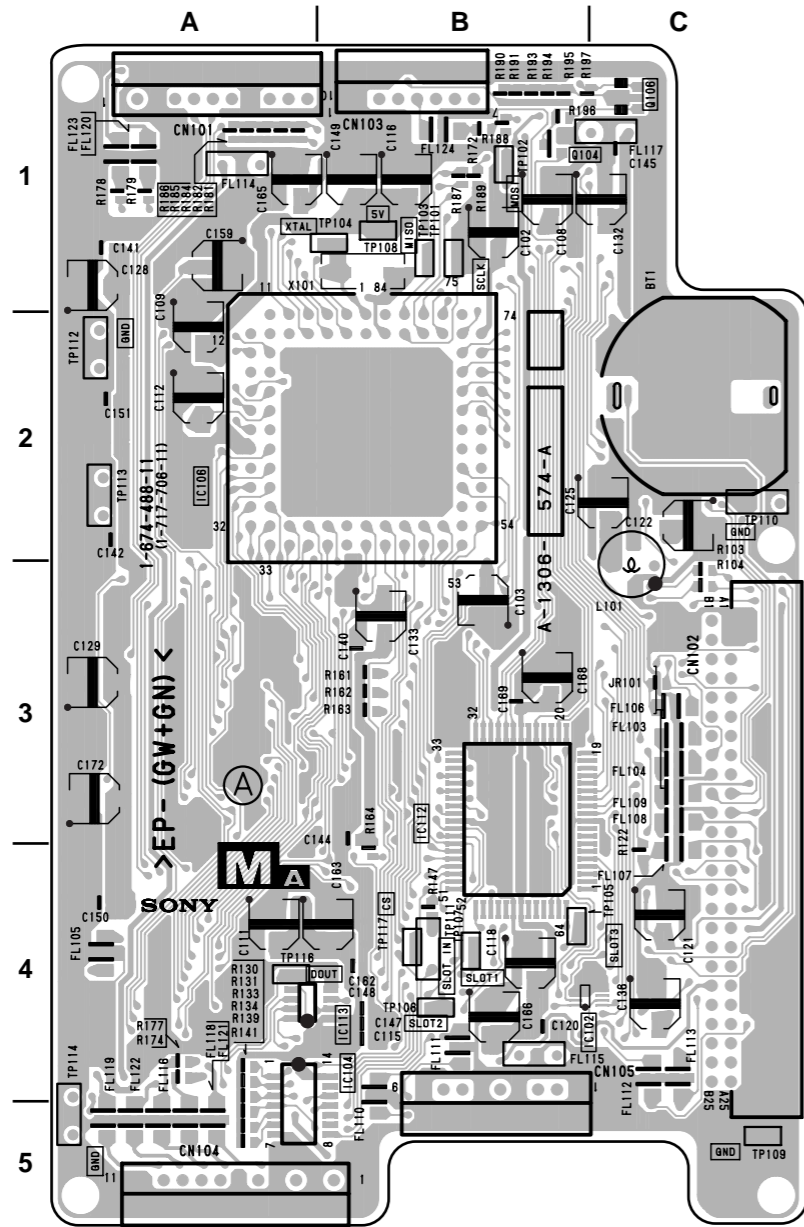

MA -A SIDE-  
SUFFIX: -11

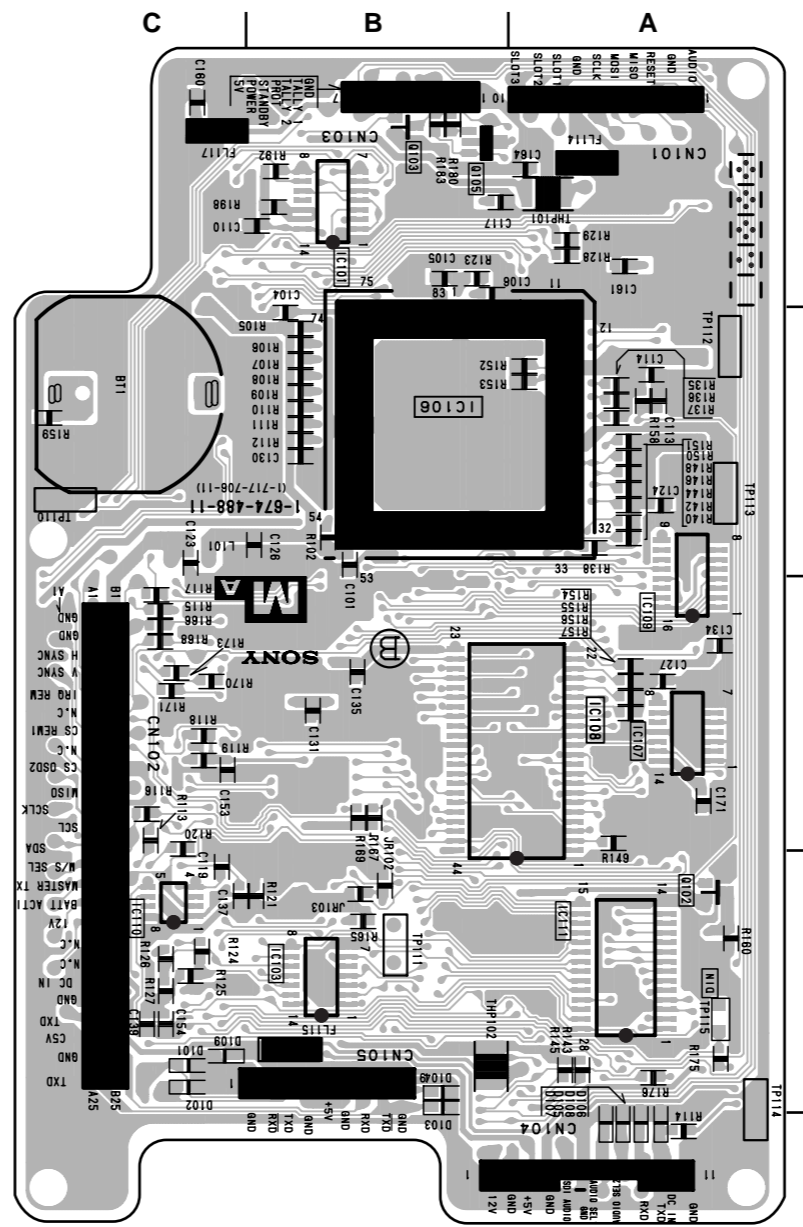

MA -B SIDE-  
SUFFIX: -11

CXD1095BQ (IC112)

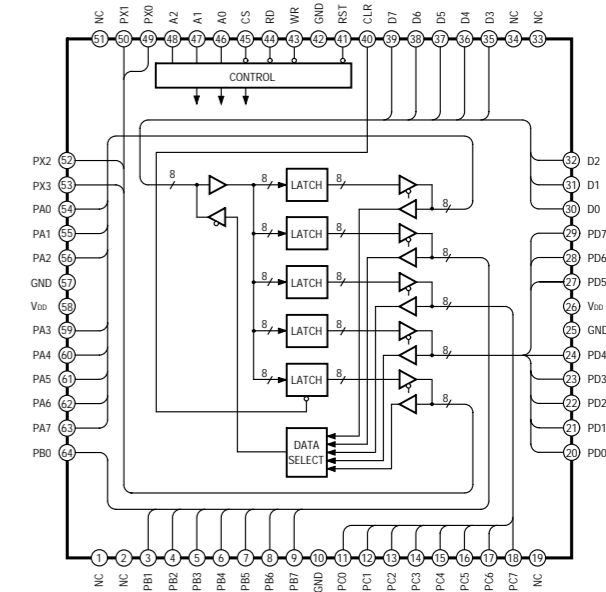

MAX490ECSA (IC113)

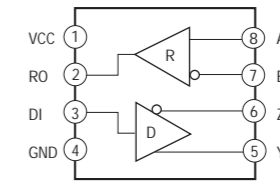

MM1026BFB (IC110)

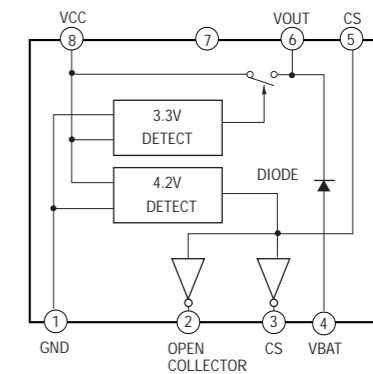

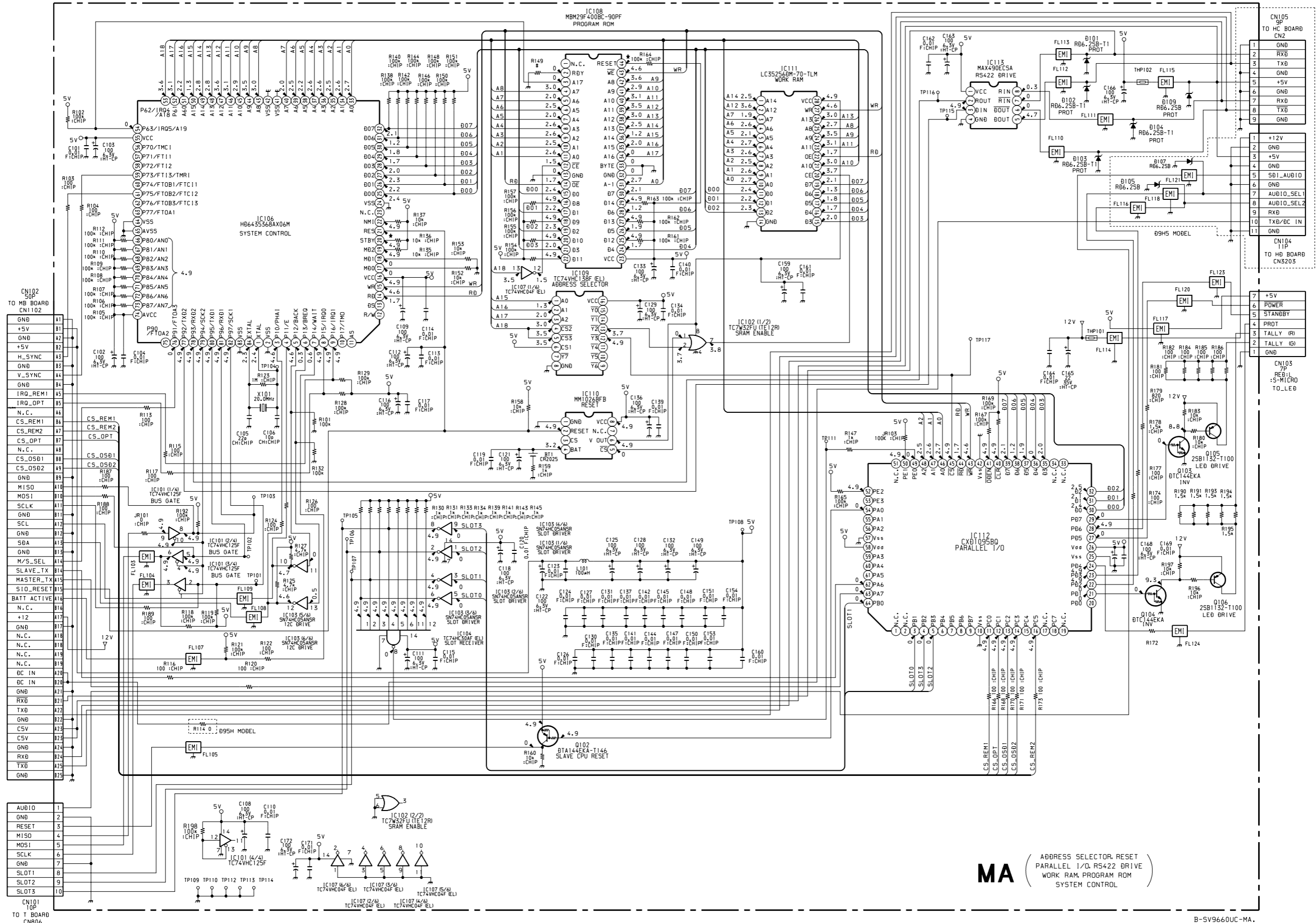

CN102 50P TO MB BOARD CN102

GND	A1
+5V	A2
GND	A3
+5V	A4
H_SYNC	A5
GND	A6
V_SYNC	A7
GND	A8
IRQ_REM1	A9
CS_REM1	A10
CS_REM2	A11
CS_OPT	A12
N.C.	A13
CS_OSD1	A14
CS_OSD2	A15
GND	A16
MISO	A17
MOSI	A18
SCLK	A19
GND	A20
SCL	A21
GND	A22
SDA	A23
GND	A24
M/S_SEL	A25
SLAVE_TX	A26
MASTER_TX	A27
SID_RESET	A28
BATT_ACTIVE	A29
N.C.	A30
+12	A31
GND	A32
N.C.	A33
N.C.	A34
N.C.	A35
N.C.	A36
DC IN	A37
DC IN	A38
GND	A39
RXB	A40
GND	A41
TXB	A42
GND	A43
CSV	A44
CSV	A45
GND	A46
RXB	A47
GND	A48
TXB	A49
GND	A50

CN101 10P TO T BOARD CN806

AUDIO	1
GND	2
RESET	3
MISO	4
MOSI	5
SCLK	6
GND	7
SLOT1	8
SLOT2	9
SLOT3	10

CN105 9P TO HC BOARD CN2

1	GND
2	RXB
3	TXB
4	GND
5	+5V
6	GND
7	RXB
8	TXB
9	GND

CN104 11P TO HD BOARD CNS205

1	+12V
2	GND
3	+5V
4	GND
5	SD1_AUDIO
6	GND
7	AUDIO_SEL1
8	AUDIO_SEL2
9	RXD
10	TXB/BC IN
11	GND

CN103 7P REB-1 :S-MICRO TO\_LED

7	+5V
6	POWER
5	STANDBY
4	PROT
3	TALLY (R)
2	TALLY (G)
1	GND

**MA** ( ADDRESS SELECTOR, RESET PARALLEL I/O, RS422 DRIVE WORK RAM, PROGRAM ROM SYSTEM CONTROL )

MB BOARD

[MB BOARD]

\* : B SIDE

- |        |       |
|--------|-------|
| D1100  | * A-3 |
| D1101  | * A-3 |
| D1102  | * A-4 |
| D1103  | * A-5 |
| D1104  | * C-1 |
| D1105  | * C-1 |
| D1106  | * C-1 |
| D1107  | * C-1 |
| D1108  | * C-1 |
| D1109  | * C-1 |
| D1110  | * A-2 |
| D1111  | * A-2 |
| D1112  | * A-2 |
| D1113  | * A-2 |
| D1114  | * A-2 |
| D1115  | * A-2 |
| D1116  | * A-1 |
| D1117  | * A-1 |
| D1118  | * C-1 |
| IC1100 | * B-1 |
| IC1101 | * A-1 |
| IC1102 | * B-1 |
| IC1103 | * A-3 |
| IC1104 | * B-3 |
| IC1105 | * C-2 |
| IC1106 | * A-2 |
| IC1107 | * B-2 |
| IC1108 | * C-2 |
| IC1109 | * C-1 |
| IC1110 | * B-3 |
| IC1112 | * B-2 |
| TP1100 | * C-2 |
| TP1101 | * B-3 |
| TP1102 | * B-3 |
| TP1103 | * B-2 |
| TP1104 | * B-2 |
| TP1106 | * B-1 |
| TP1107 | * C-1 |
| TP1108 | * C-2 |
| TP1109 | * B-3 |
| TP1110 | * C-2 |
| TP1111 | * B-4 |
| TP1112 | * C-4 |
| TP1113 | * C-4 |

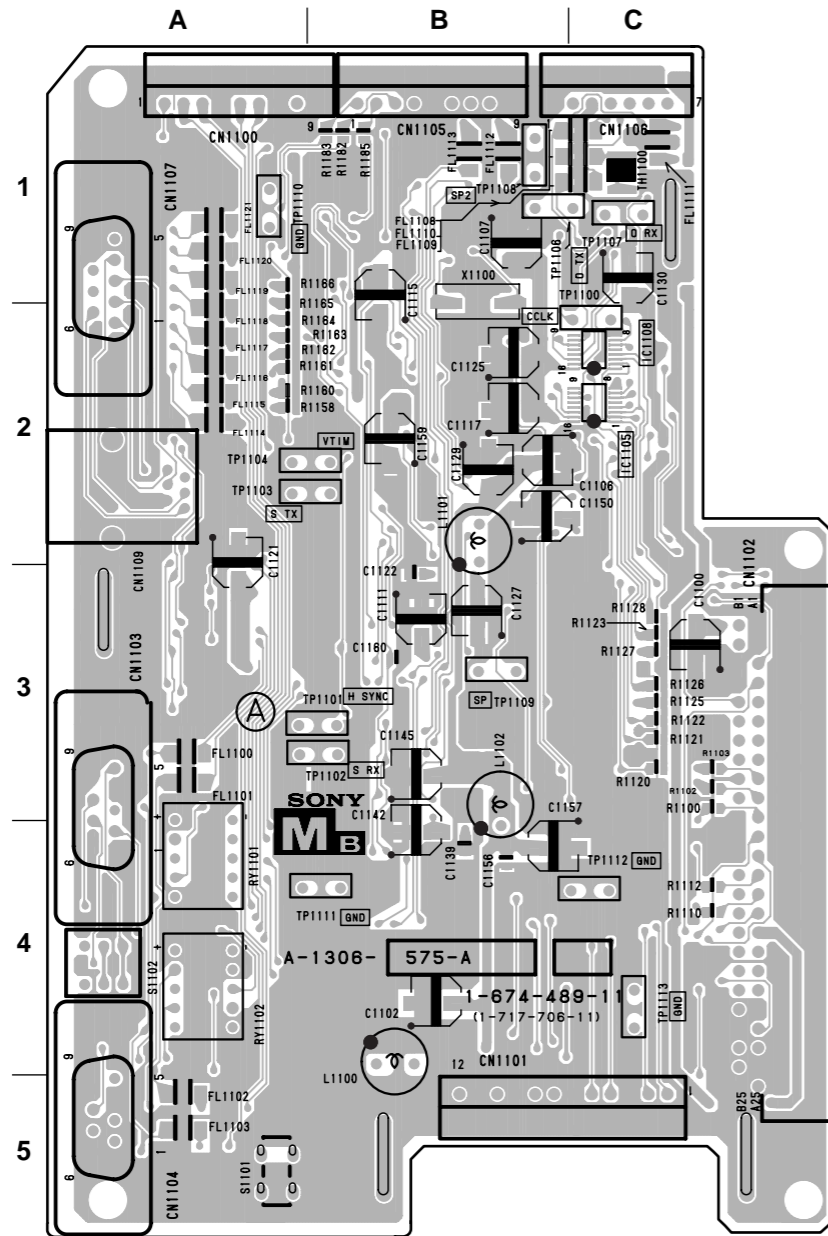

MB -A SIDE-  
SUFFIX: -11

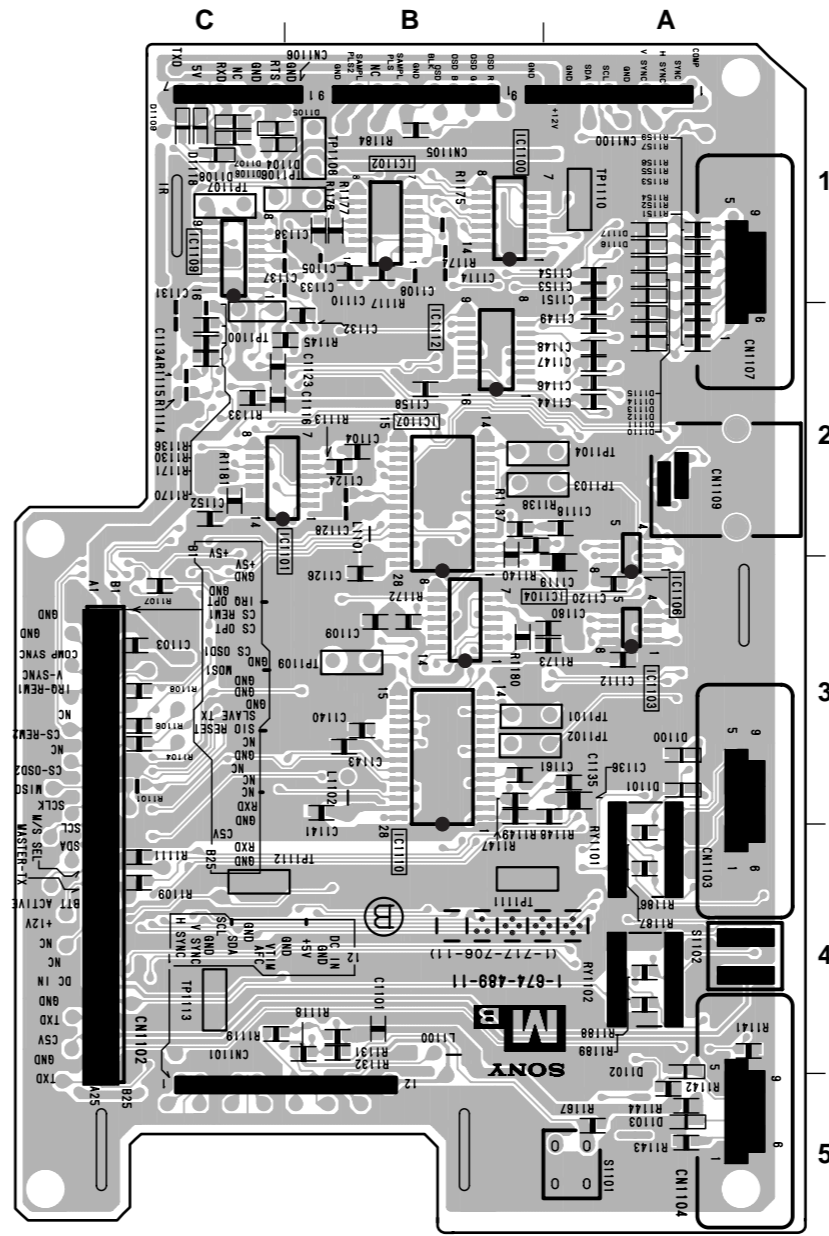

MB -B SIDE-  
SUFFIX: -11



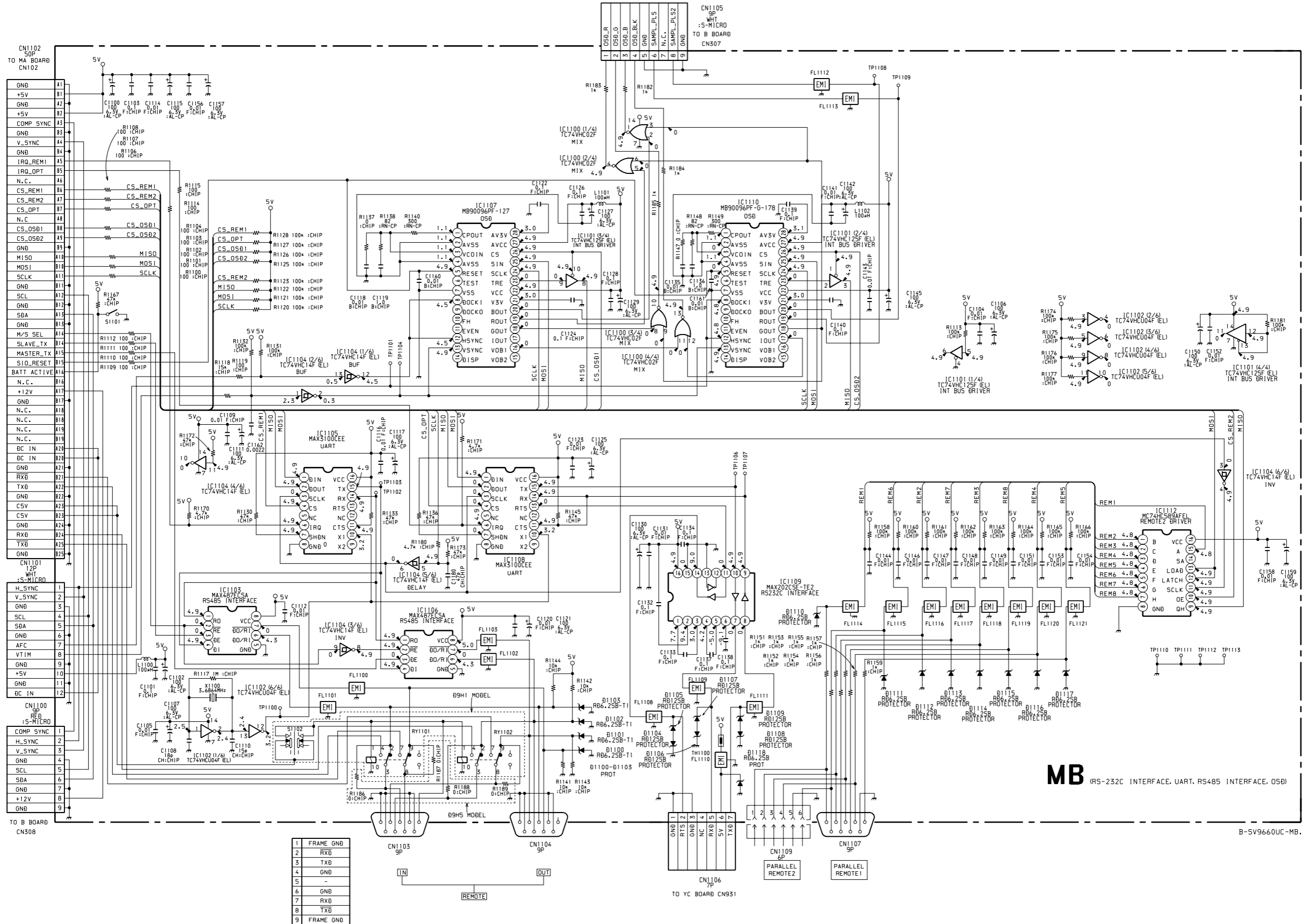

1	FRAME GND
2	RXD
3	TXD
4	GND
5	-
6	GND
7	RXD
8	TXD
9	FRAME GND

**MB** (RS-232C INTERFACE, UART, RS485 INTERFACE, OSD)  
B-SV9660UC-MB.

MAX3100CEE (IC1105, 1108)

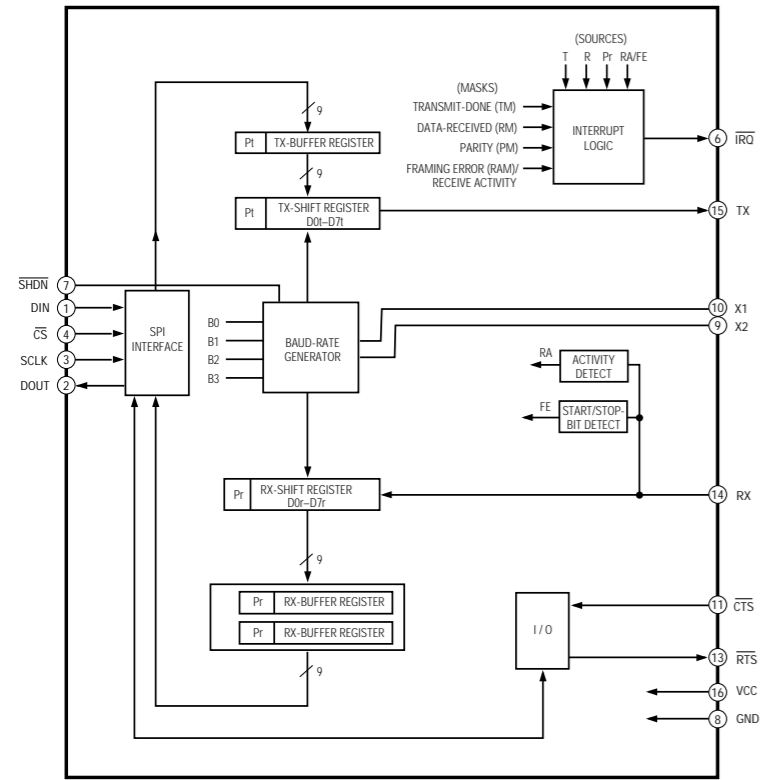

MB90096PF-127/G-178 (IC1107, 1110)

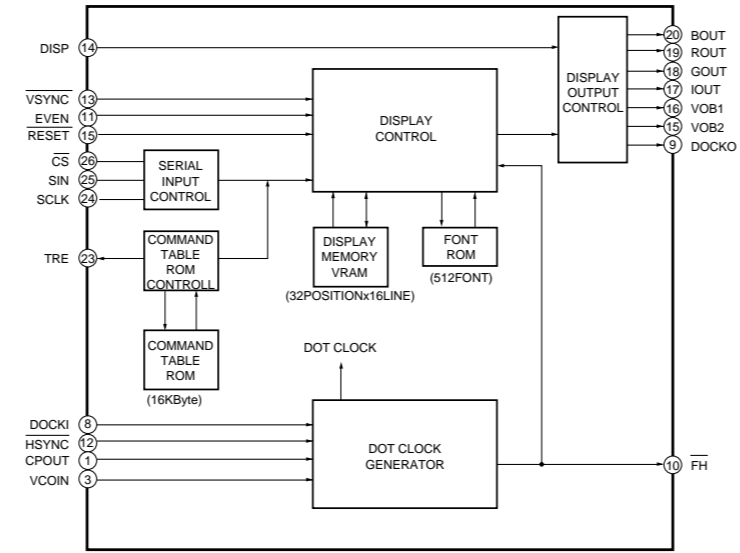

MAX487ECSA (IC1103, 1106)

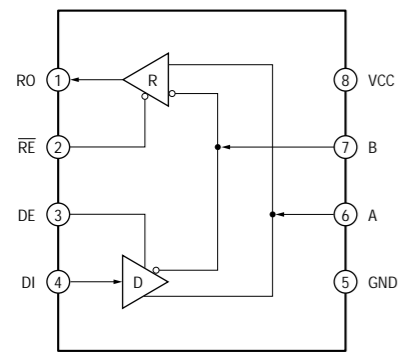

MC74HC589AFEL (IC1112)

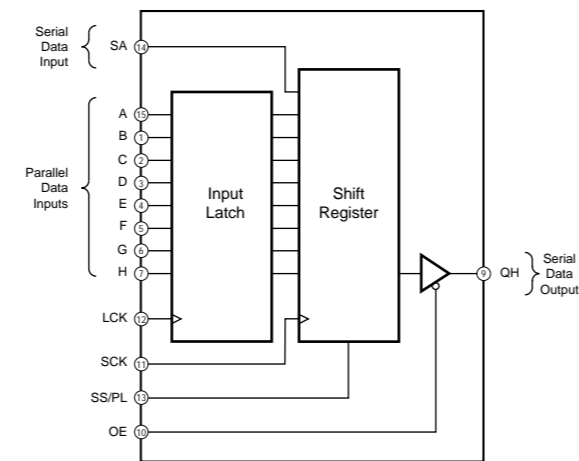

CXA1544M-T6 (IC502)

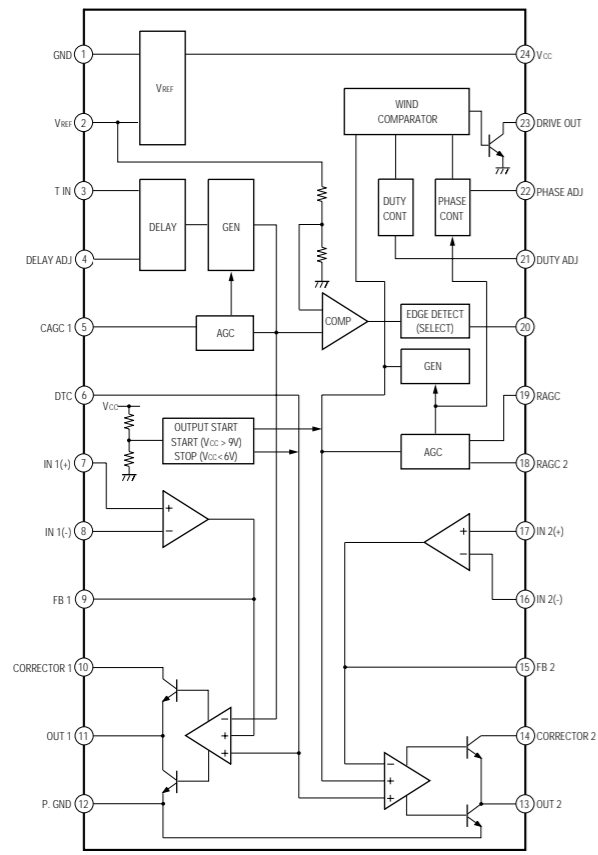

NJM2360AM (TE2) (IC510)

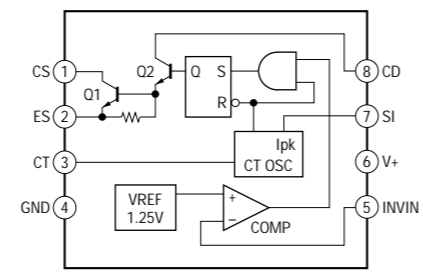

TL494CNS-E20 (IC503)

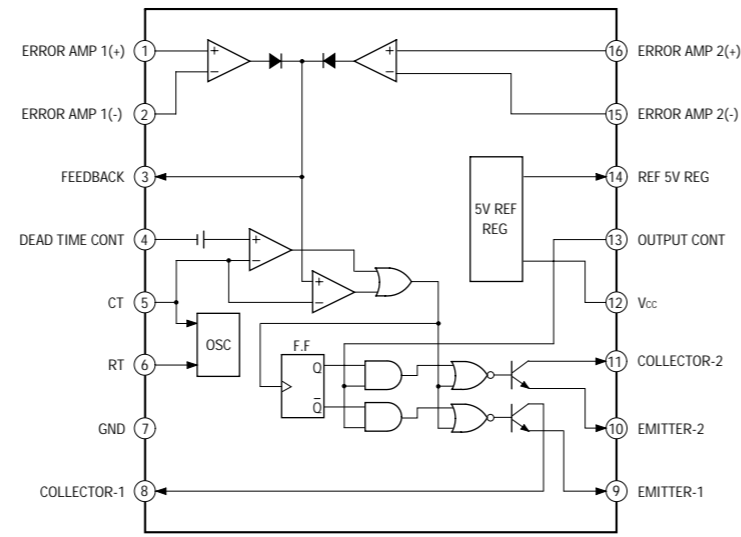

IR2112 (IC506)

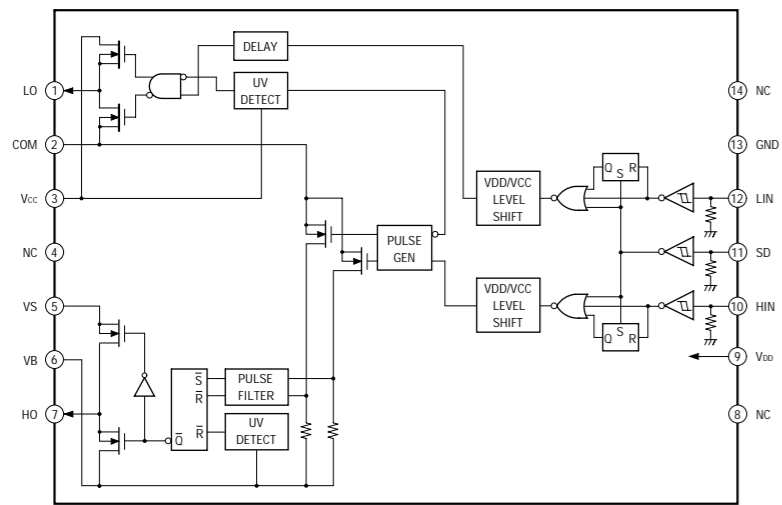

[P BOARD]

\*: B SIDE

- |       |       |       |     |
|-------|-------|-------|-----|
| D501  | * C-6 | TP501 | C-6 |
| D502  | * B-6 | TP502 | A-5 |
| D503  | C-6   | TP503 | A-5 |
| D504  | * B-6 | TP504 | A-5 |
| D505  | C-6   | TP505 | B-1 |
| D506  | * B-1 | TP506 | C-4 |
| D507  | * A-1 | TP507 | C-5 |
| D508  | * A-5 | TP508 | C-3 |
| D509  | * C-4 | TP509 | B-5 |
| D510  | * A-6 | TP511 | B-1 |
| D511  | * C-4 | TP513 | C-6 |
| D512  | * C-5 | TP514 | A-6 |
| D513  | * C-5 | TP515 | A-1 |
| D514  | * C-5 | TP516 | A-1 |
| D515  | * C-4 |       |     |
| D516  | * C-5 |       |     |
| D517  | * B-4 |       |     |
| D518  | * B-1 |       |     |
| D519  | * B-1 |       |     |
| D520  | * A-5 |       |     |
| D521  | * B-1 |       |     |
| D522  | * B-1 |       |     |
| D523  | C-3   |       |     |
| D524  | C-4   |       |     |
| D525  | C-2   |       |     |
| D526  | C-1   |       |     |
| D527  | C-2   |       |     |
| D528  | * B-1 |       |     |
| D529  | * B-1 |       |     |
| D530  | * C-1 |       |     |
| D531  | * C-2 |       |     |
| D532  | * C-4 |       |     |
| D533  | * B-1 |       |     |
| D534  | * B-1 |       |     |
| D535  | * B-4 |       |     |
| D536  | * A-4 |       |     |
| D537  | * C-2 |       |     |
| D538  | * C-4 |       |     |
| D539  | C-4   |       |     |
| D540  | C-4   |       |     |
| IC501 | A-5   |       |     |
| IC502 | B-6   |       |     |
| IC503 | B-3   |       |     |
| IC504 | * C-4 |       |     |
| IC505 | C-5   |       |     |
| IC506 | C-4   |       |     |
| IC507 | B-1   |       |     |
| IC508 | C-3   |       |     |
| IC509 | B-1   |       |     |
| IC510 | C-1   |       |     |
| IC511 | C-4   |       |     |
| Q502  | * B-6 |       |     |
| Q503  | * B-4 |       |     |
| Q504  | * B-5 |       |     |
| Q505  | * A-1 |       |     |
| Q506  | * A-5 |       |     |
| Q507  | * A-1 |       |     |
| Q508  | * A-1 |       |     |
| Q509  | * A-5 |       |     |
| Q510  | * A-5 |       |     |
| Q511  | * A-4 |       |     |
| Q512  | * A-4 |       |     |
| Q513  | * A-4 |       |     |
| Q514  | * A-4 |       |     |
| Q515  | * B-6 |       |     |
| Q516  | * B-6 |       |     |
| Q517  | * C-4 |       |     |
| Q518  | * C-3 |       |     |
| Q519  | * B-6 |       |     |
| Q520  | * A-4 |       |     |
| Q521  | * B-1 |       |     |
| Q522  | * B-1 |       |     |
| Q523  | * B-1 |       |     |
| Q524  | * B-6 |       |     |
| Q525  | * B-4 |       |     |
| Q526  | * B-4 |       |     |
| Q527  | * B-4 |       |     |
| Q528  | * B-4 |       |     |
| Q529  | C-4   |       |     |
| Q530  | C-4   |       |     |

P BOARD

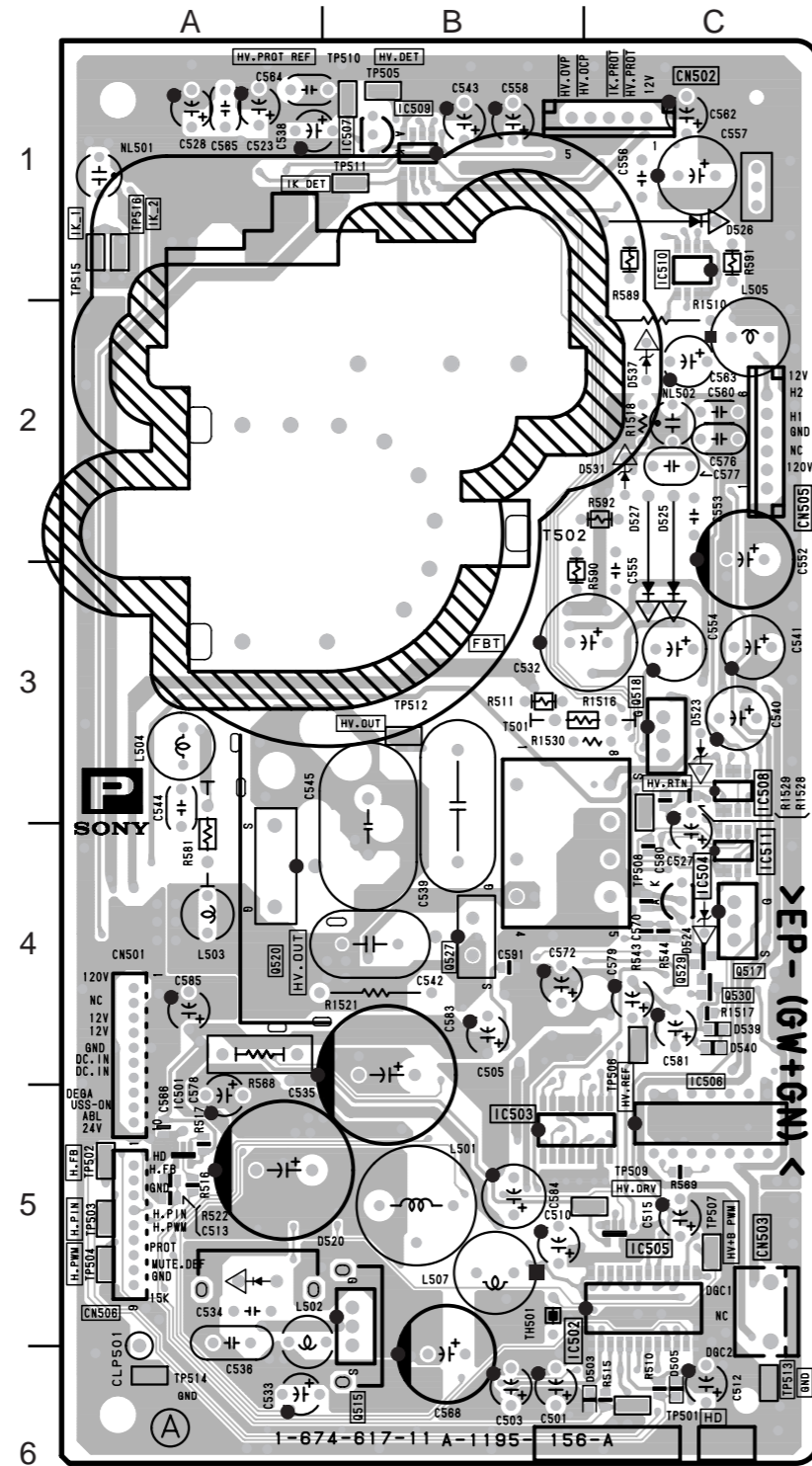

P -A SIDE-  
SUFFIX: -11

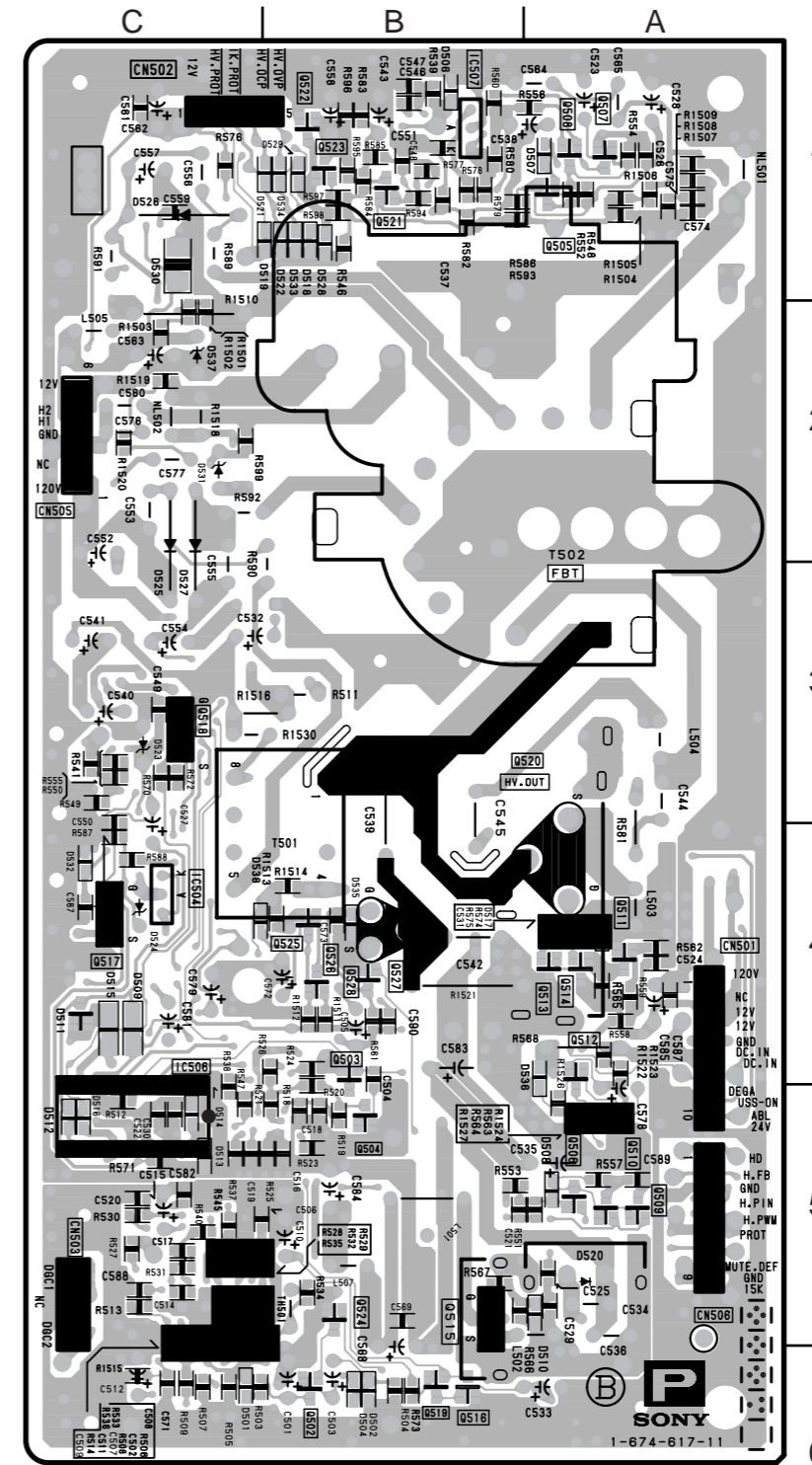

P -B SIDE-  
SUFFIX: -11

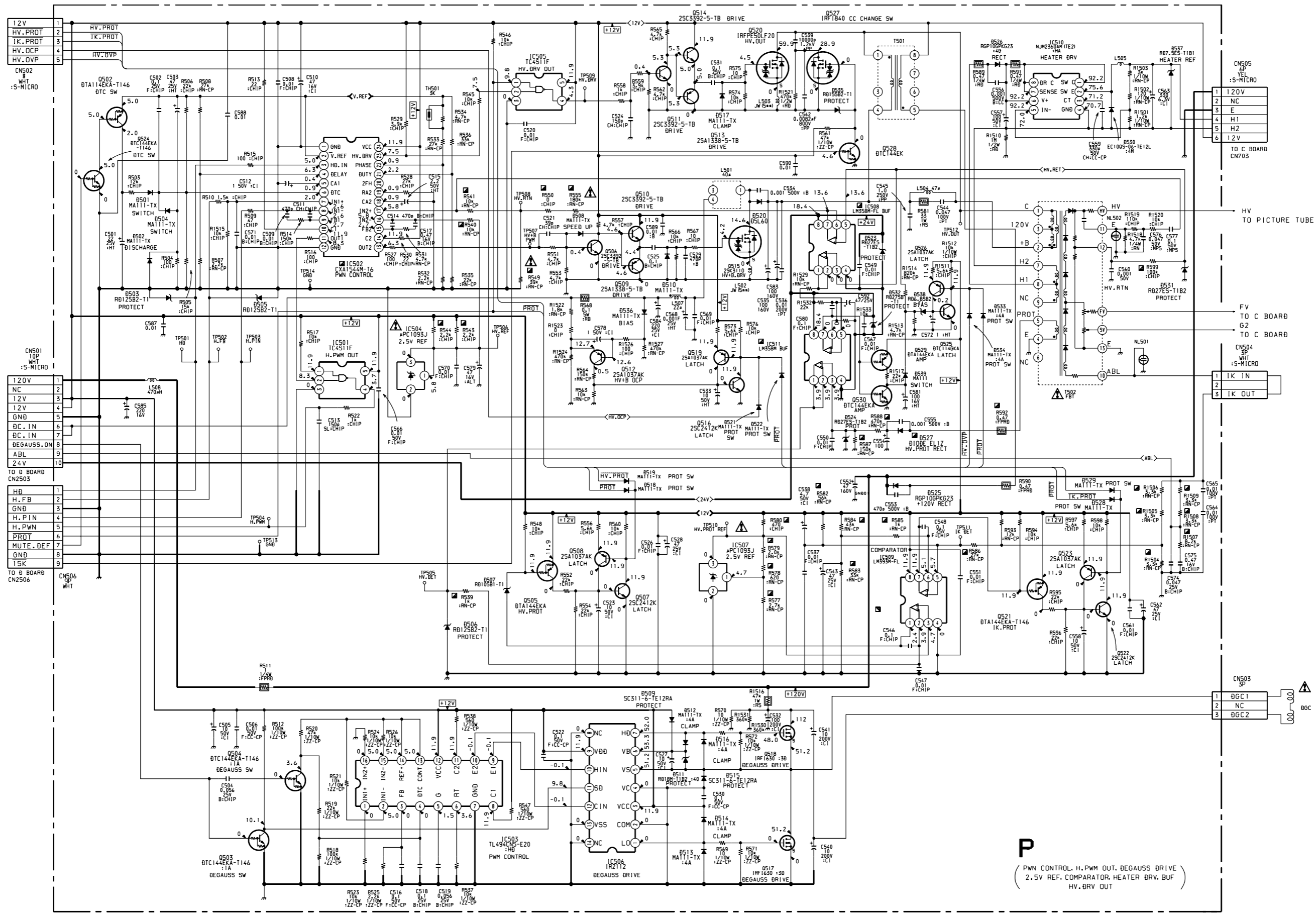

**P**  
 (PWN CONTROL, H.PWM OUT, DEGAUSS DRIVE)  
 (2.5V REF, COMPARATOR, HEATER DRV, BUF)  
 HV.DRV OUT

B-5V9660UC-P..

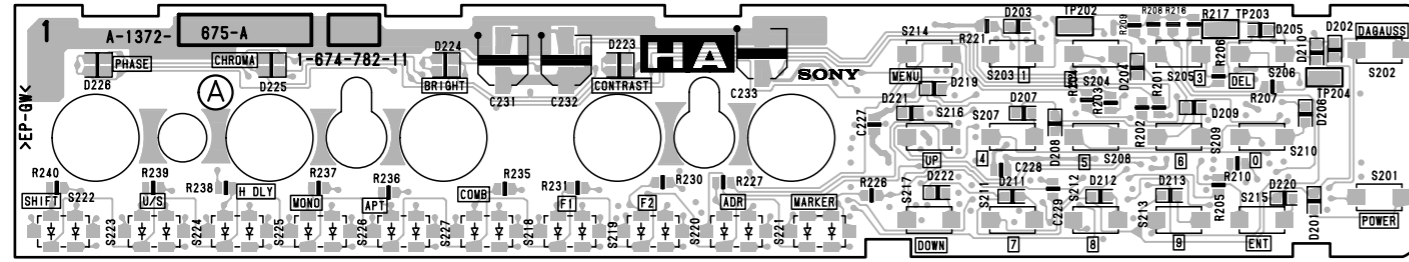

**HA -A SIDE-**  
SUFFIX: -11

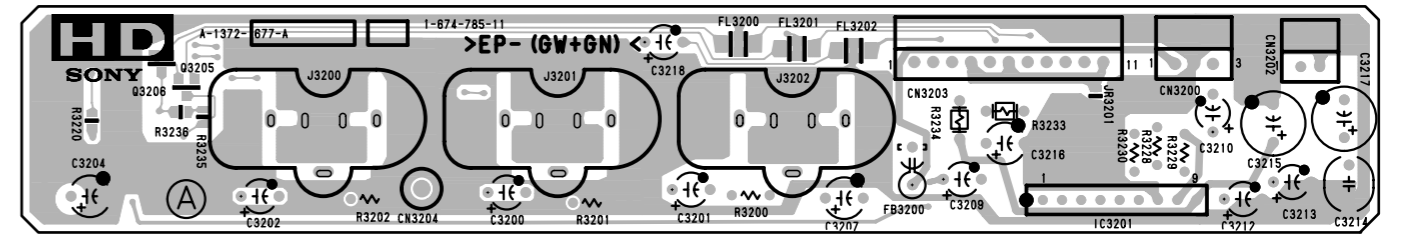

**HD -A SIDE-**  
SUFFIX: -11

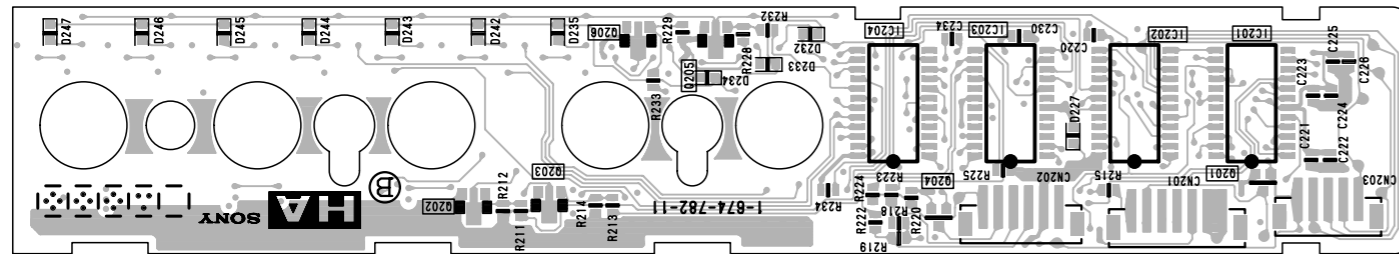

**HA -B SIDE-**  
SUFFIX: -11

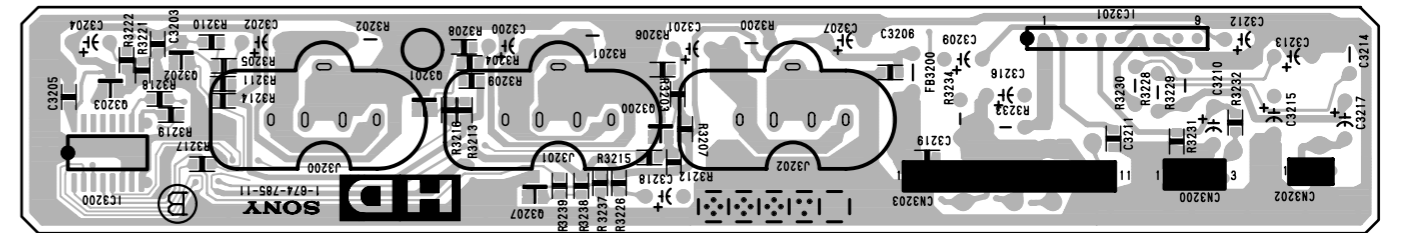

**HD -B SIDE-**  
SUFFIX: -11

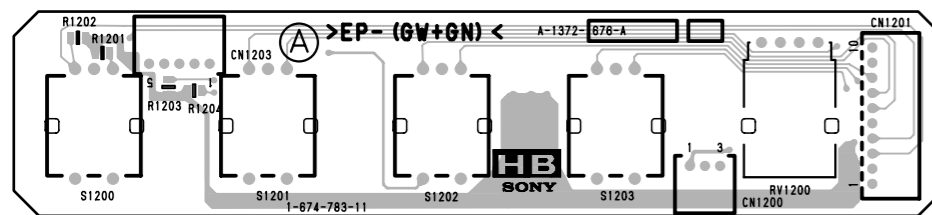

**HB -A SIDE-**  
SUFFIX: -11

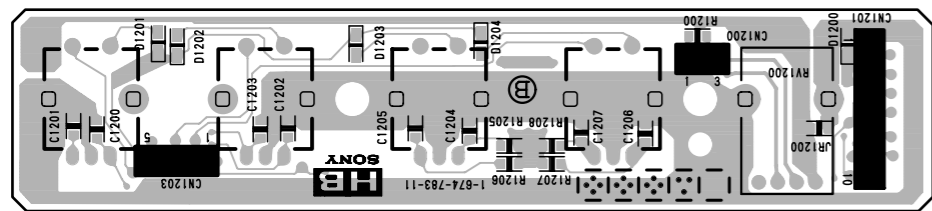

**HB -B SIDE-**  
SUFFIX: -11

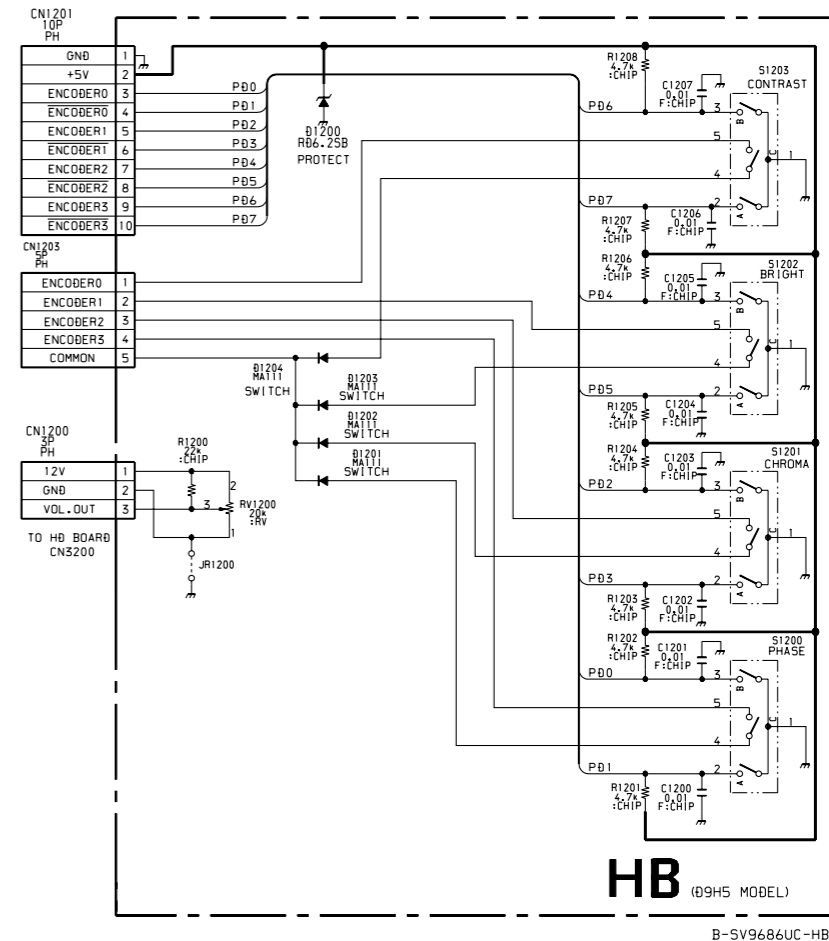
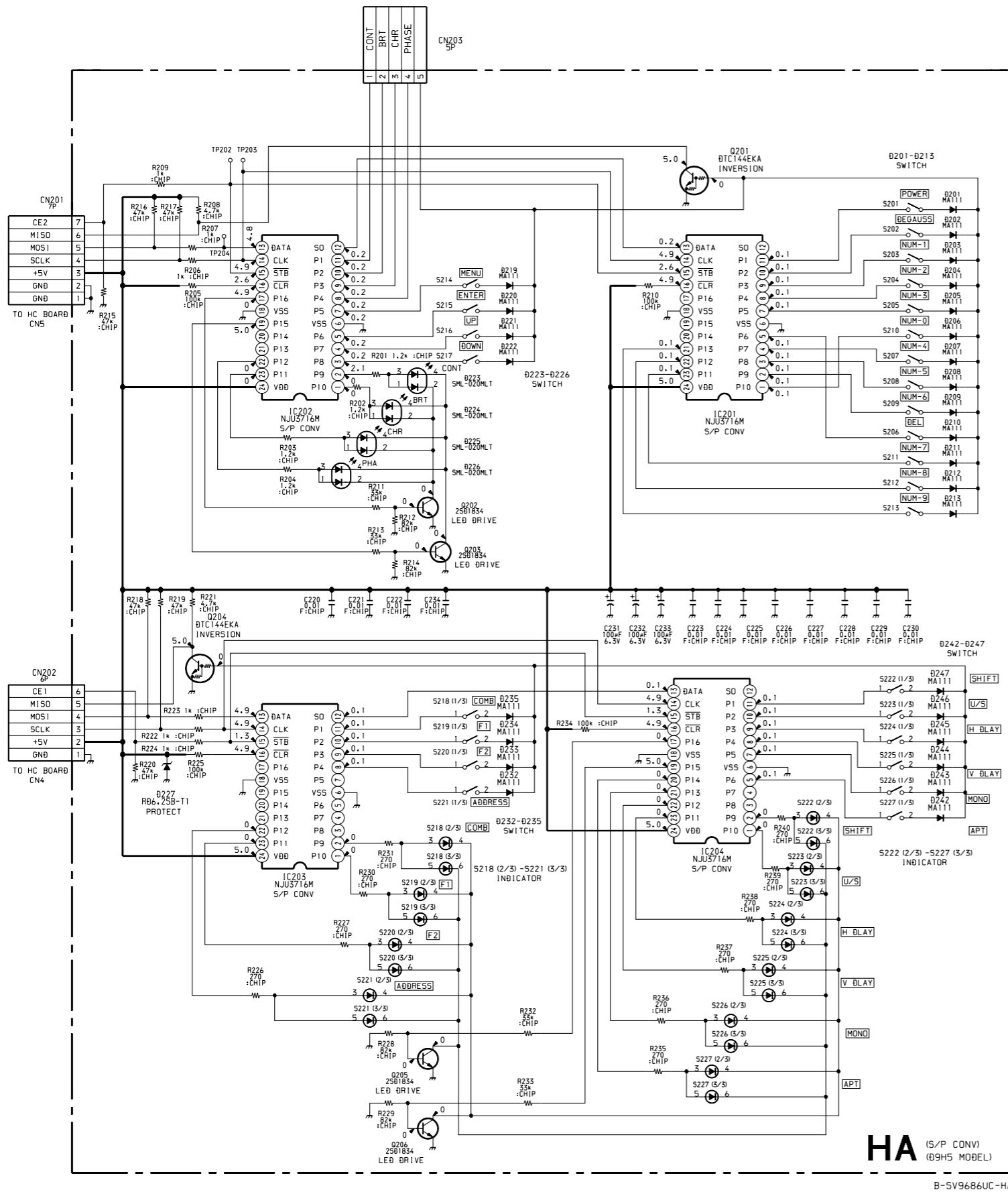

NJU3716M (IC201, 202, 203, 204)

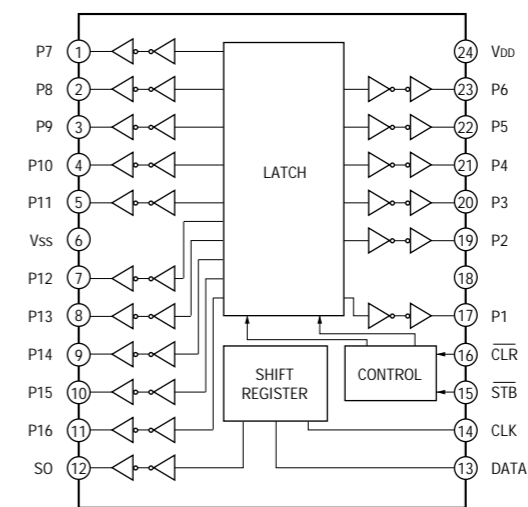

AN5265 (IC3201)

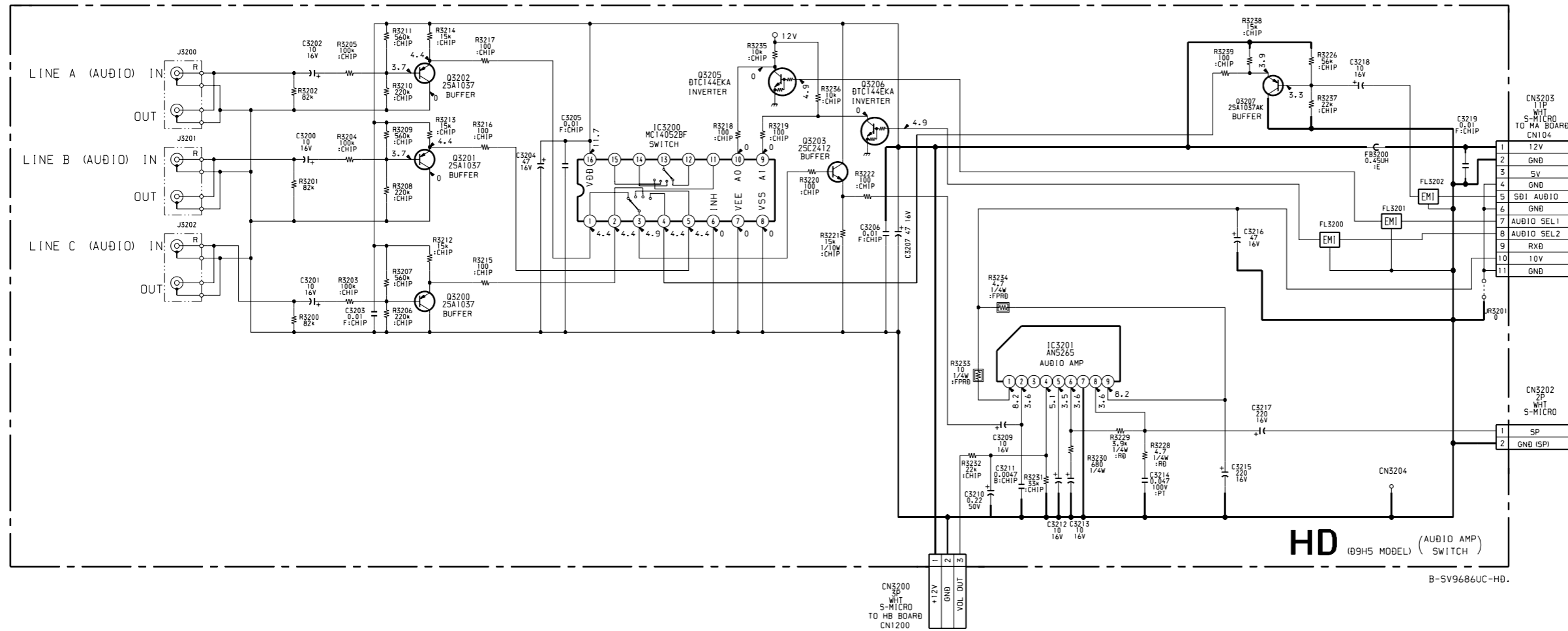
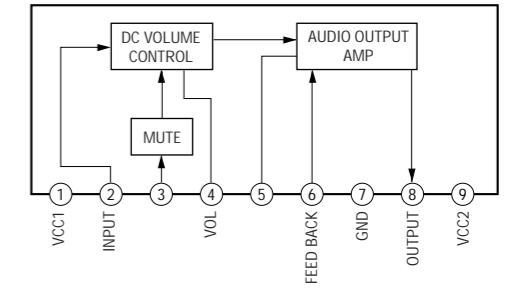

1	12V
2	GND
3	5V
4	GND
5	SBI AUB10
6	GND
7	AUDIO SEL1
8	AUDIO SEL2
9	RXB
10	10V
11	GND

1	SP
2	GND (SP)

1	+12V
2	GND
3	VOL OUT

B-SV9686UC-HD.





**YA -B SIDE-**  
SUFFIX: -11

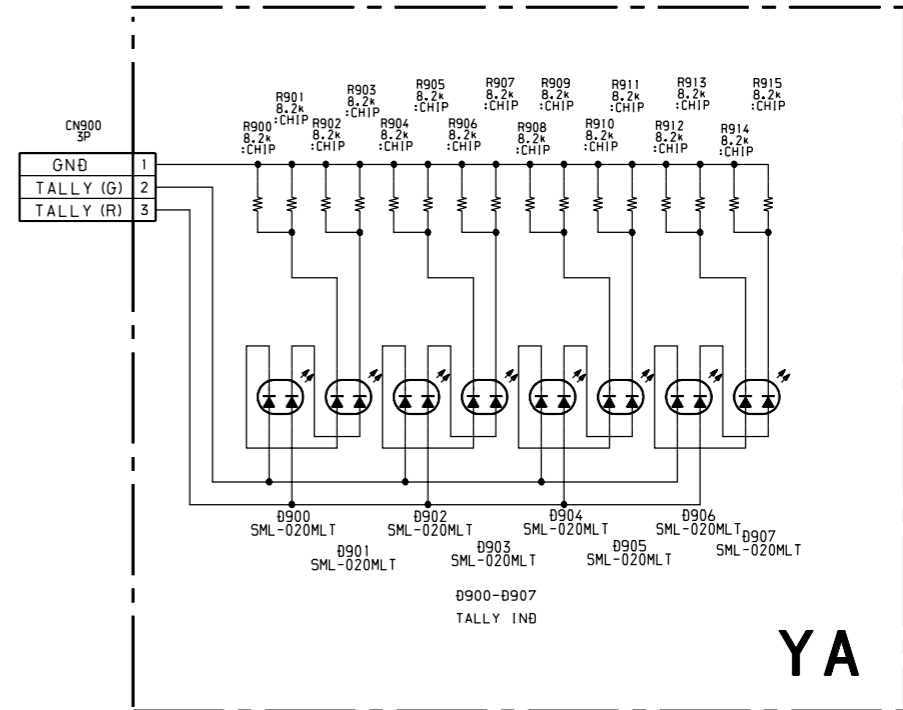

B-SV9660UC-YA.



**YB -B SIDE-**  
SUFFIX: -11

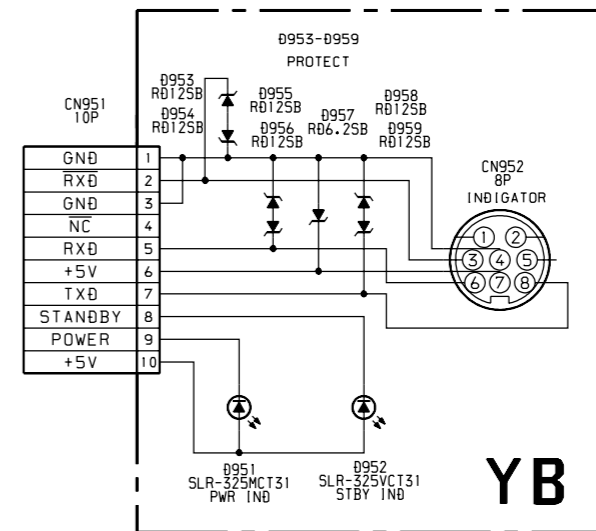

B-SV9660UC-YB.

HC BOARD

[HC BOARD]

\*:B SIDE

D1	* A-1
D2	* A-1
D3	* A-1
D4	A-1
D5	A-1
D6	* A-2
D7	* A-3
D8	* A-2
D9	A-1
IC1	B-2
IC2	A-1
IC3	B-3
IC4	* B-5
IC5	* B-4
IC6	* B-3
IC7	* B-3
IC8	* B-5
IC9	B-1
IC10	B-1
IC11	B-2
IC13	A-1
IC14	B-2
IC21	* B-4
Q4	A-3
TP2	A-1
TP3	A-1
TP4	A-2
TP6	C-1
TP7	C-3
TP8	C-3
TP9	B-3

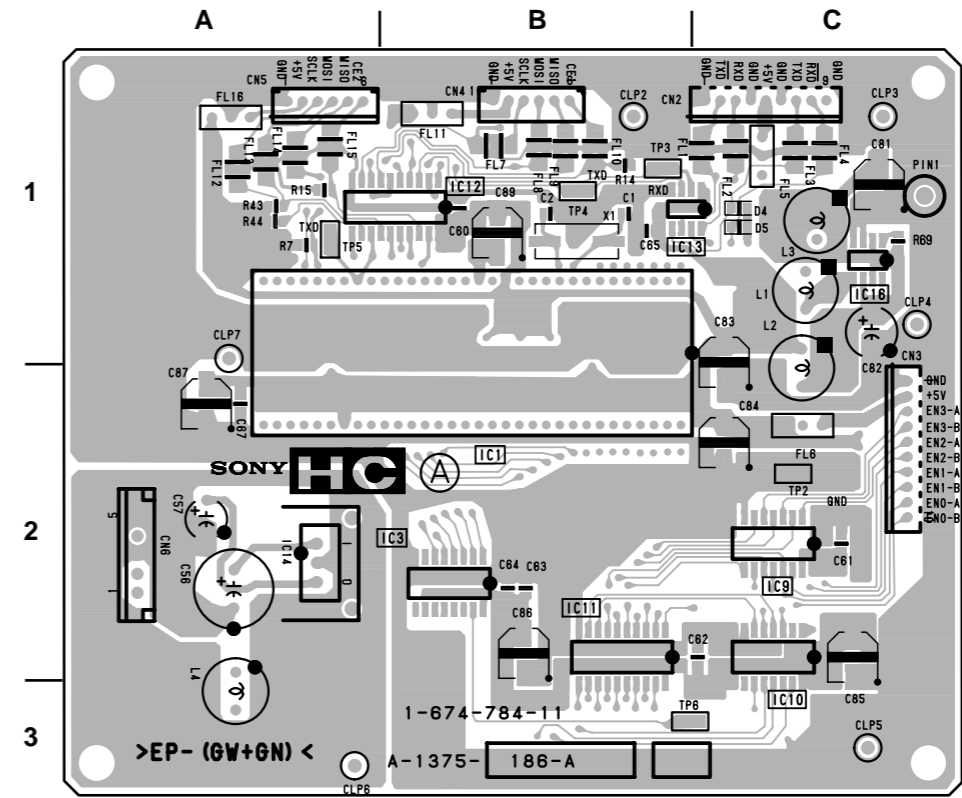

HC -A SIDE-  
SUFFIX: -11

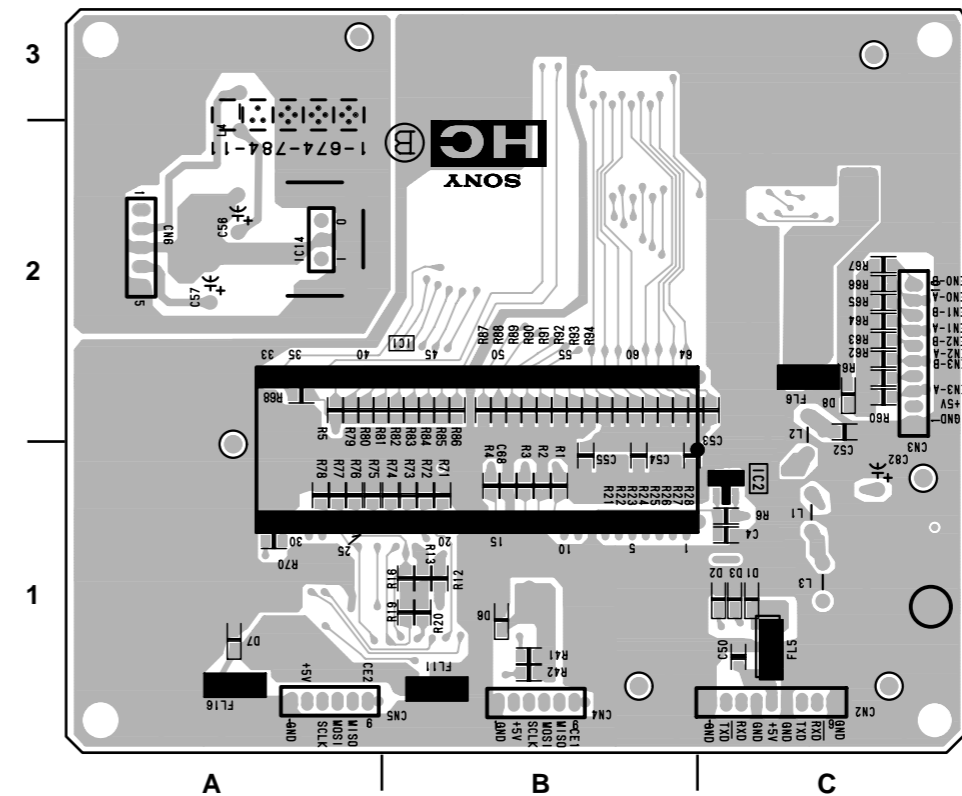

HC -B SIDE-  
SUFFIX: -11

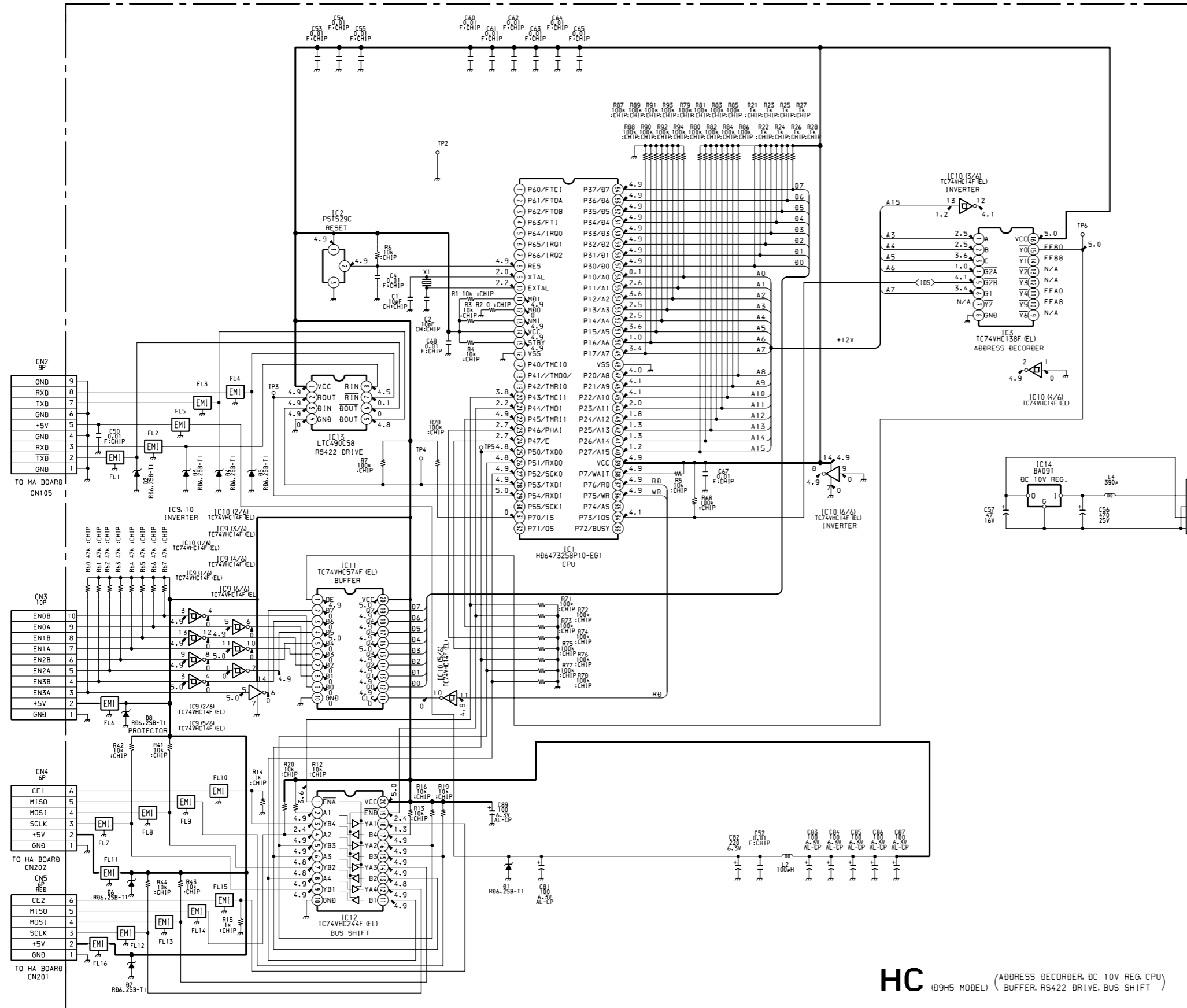

LTC490CS8 (IC13)

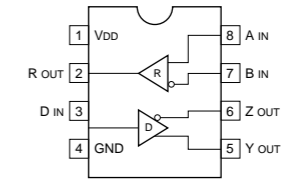

TC74VHC138F (EL) (IC3)

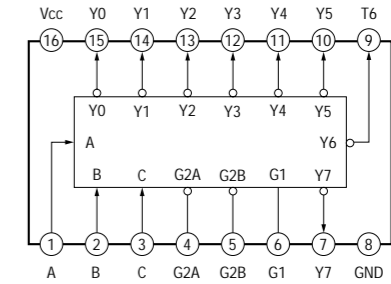

TC74VHC244F (EL) (IC12)

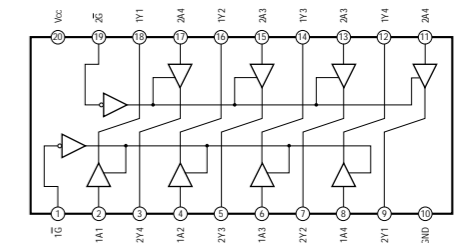

TC74VHC574F (EL) (IC11)

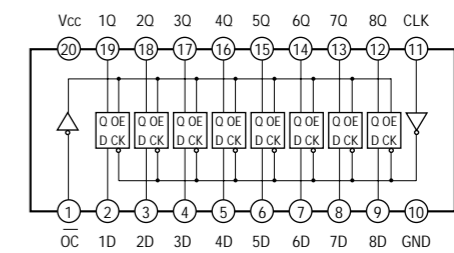

HC (ADDRESS DECODER, DC 10V REG, CPU) (BUFFER, RS422 DRIVE, BUS SHIFT)

B-5V9686UC-HC.

T BOARD

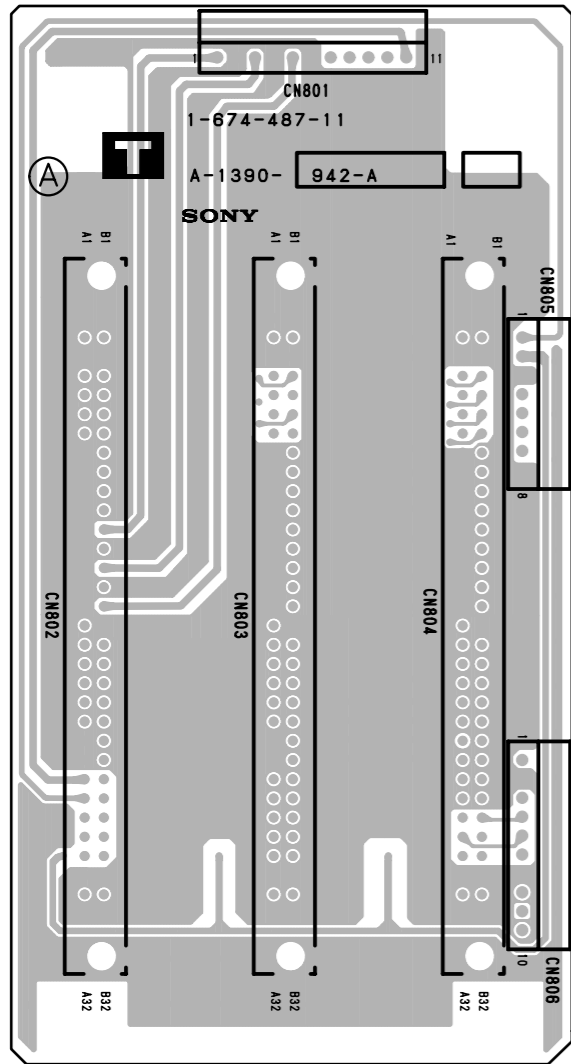

T -A SIDE-  
SUFFIX: -11

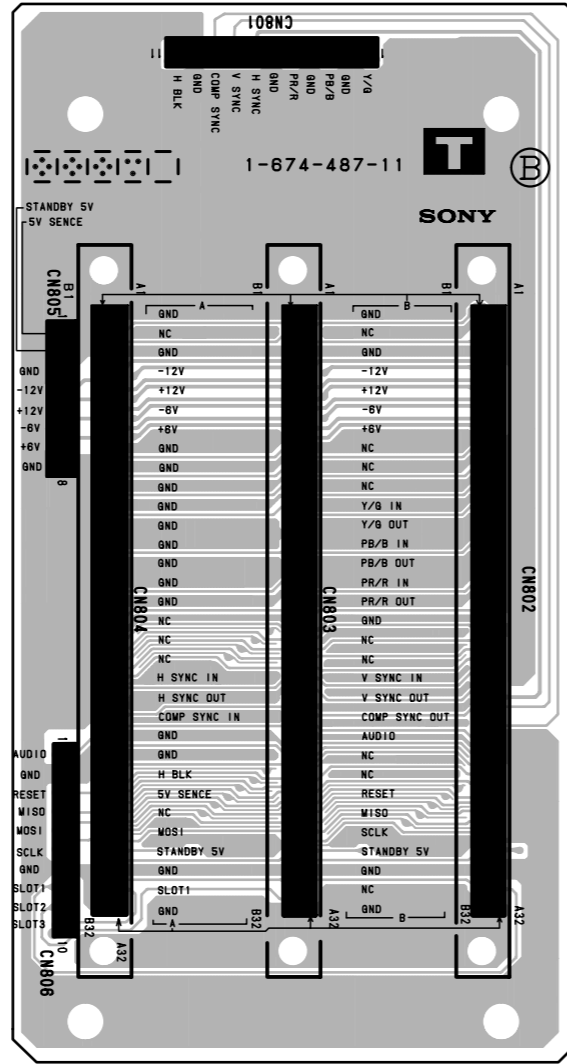

T -B SIDE-  
SUFFIX: -11

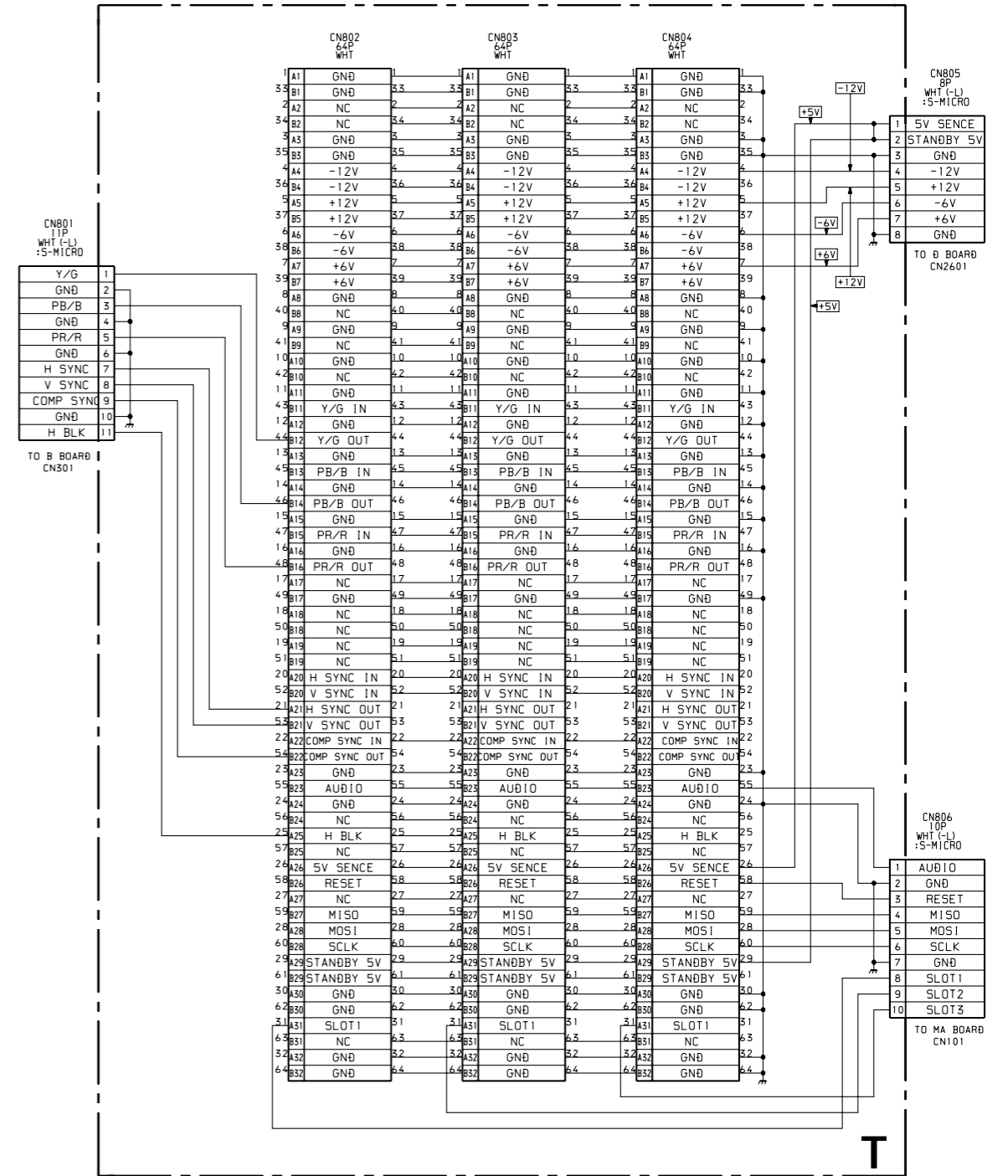

The material contained in this manual consists of information that is the property of Sony Corporation. Sony Corporation expressly prohibits the duplication of any portion of this manual or the use thereof for any purpose other than the operation or maintenance of the equipment described in this manual without the express written permission of Sony Corporation.

Le matériel contenu dans ce manuel consiste en informations qui sont la propriété de Sony Corporation. Sony Corporation interdit formellement la copie de quelque partie que ce soit de ce manuel ou son emploi pour tout autre but que des opérations ou entretiens de l'équipement à moins d'une permission écrite de Sony Corporation.

Das in dieser Anleitung enthaltene Material besteht aus Informationen, die Eigentum der Sony Corporation sind. Die Sony Corporation untersagt ausdrücklich die Vervielfältigung jeglicher Teile dieser Anleitung oder den Gebrauch derselben für irgendeinen anderen Zweck als die Bedienung oder Wartung der in dieser Anleitung beschriebenen Ausrüstung ohne ausdrückliche schriftliche Erlaubnis der Sony Corporation.

