



VTR

Broadcast Products Technical Bulletin 20-2002-167

DATE: **July 15, 2002**SUBJECT: **STATUS INDICATOR BLINKS RED;
FILTERS NEED CLEANING AFTER 24 HOURS**MODEL: **PFV-HD300**SERIAL NO: **ALL**

DESCRIPTION

If internal temperature exceeds the allowable range, the status indicator blinks red. If the temperature continues to rise, the protection circuit in the power supply activates and shuts down the power supply.

If the status indicator blinks red, clean the filters and the fan shield assembly as described in Technical Bulletin 20-2002-166.

If the unit is operating in high temperature or dusty environments and the filters need to be cleaned again after 24 hours, replace the fan shield assembly with a fan guard assembly as described in the following modification procedure.

PARTS REQUIRED

Part No.	Description	Qty.
3-168-032-01	Fan Guard Assembly	4

ORDERING INFORMATION

NOTE: To order upgrades or for regional service center and parts ordering information, refer to the following document, which lists all contact telephone numbers:

Technical Bulletin 001999000

MODIFICATION PROCEDURE

WARNING: Turn off the unit and unplug the power cord from the outlet before replacing the assembly. Turning off power is not enough to prevent electric shock.

1. Remove the fan shield cover and the fan shield assembly by removing eight screws. (See Figure 1.)
2. Discard the fan shield assembly.
3. Install the DC fan, fan shield cover, and fan guards as shown in Figure 2.

HDVM01-167

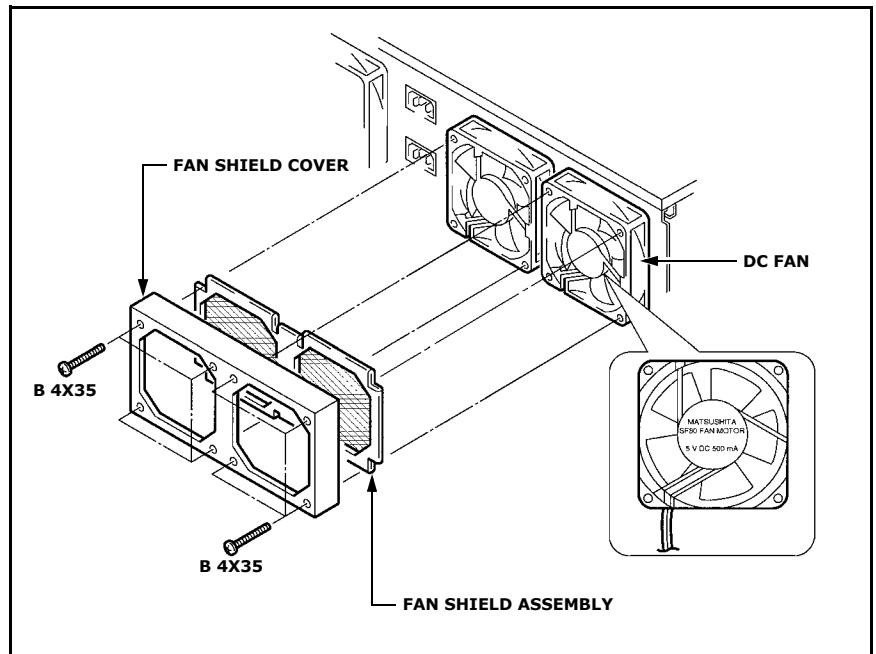

Figure 1

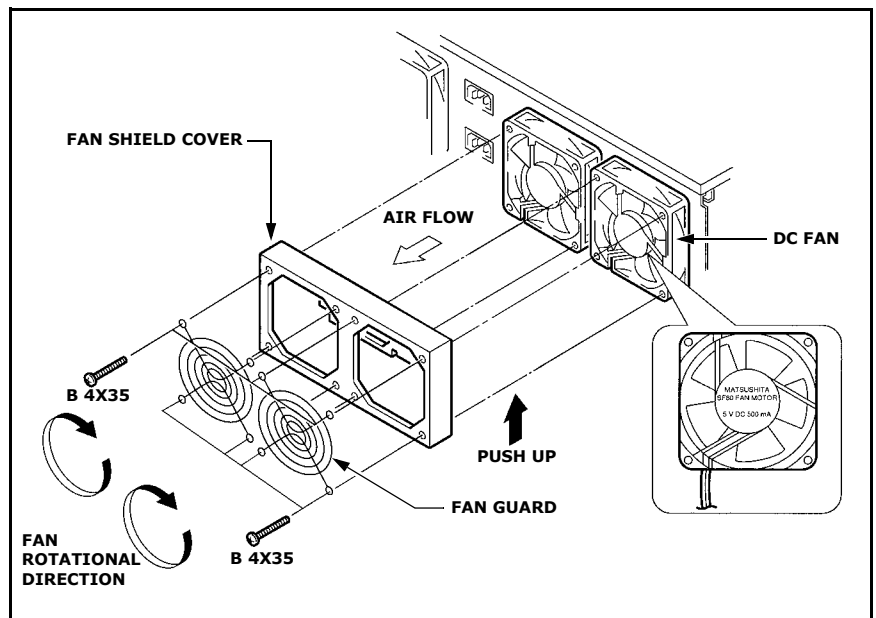

Figure 2

CAUTION:

- Take care to install the DC fan correctly so that:
 - The fan rotates in the proper direction.
 - The fan harness is not pinched by the fan shield cover.
- Do not discard the fan shield cover, which is required to prevent unwanted radiation.
- Install the fan shield cover while pushing it up.