

Magnavox

SERVICE MANUAL

THE MAGNAVOX COMPANY · SERVICE DEPARTMENT
FORT WAYNE, INDIANA

Manual No. 6500

File: 1974 "D" Series (Volume 11)
Miscellaneous Section
Second Issue: May, 1975

1TL200 BLAK & BK12 ODYSSEY GAME SIMULATOR

Scanned by Sly DC (2018)

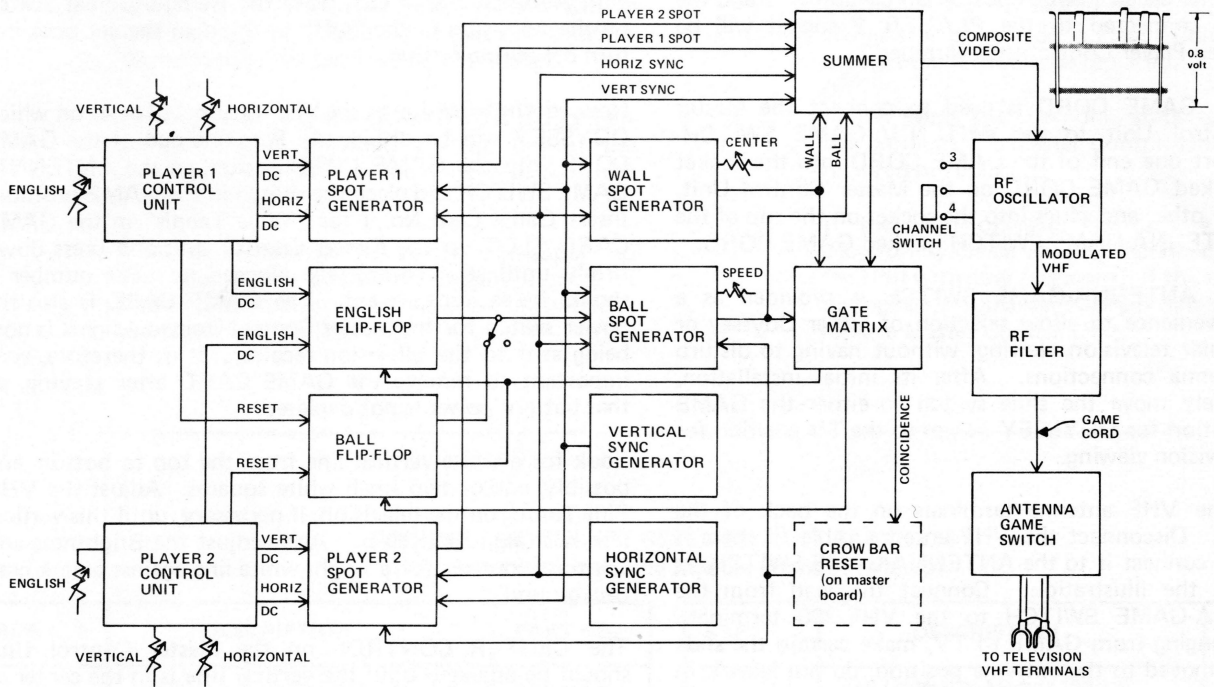

Figure 1 -- Odyssey Block Diagram

GENERAL DESCRIPTION

Odyssey is an electronic game simulator developed by Magnavox as a consumer leisure time product. The basic Odyssey set consists of a Master Control Unit, Game Cards, two Player Control Units, Antenna-Game Switch Box and the cables necessary to interconnect the electronics. Also included are game Overlays, Instruction Book, Poker Chips, etc., for playing the various games. Accessories such as the Rifle are available as options.

DMFWP274

The Master Control Unit consists of a master board and 12 solid-state plug-in modules. Figure 1 is the block diagram of the Odyssey system excluding the television set.

The Odyssey game is connected as shown in Figure 2. The Master Control Unit generates the video, sync and RF signals necessary to produce two Players, a Ball and a Wall on the television screen.

Printed in U.S.A., Copyright 1975

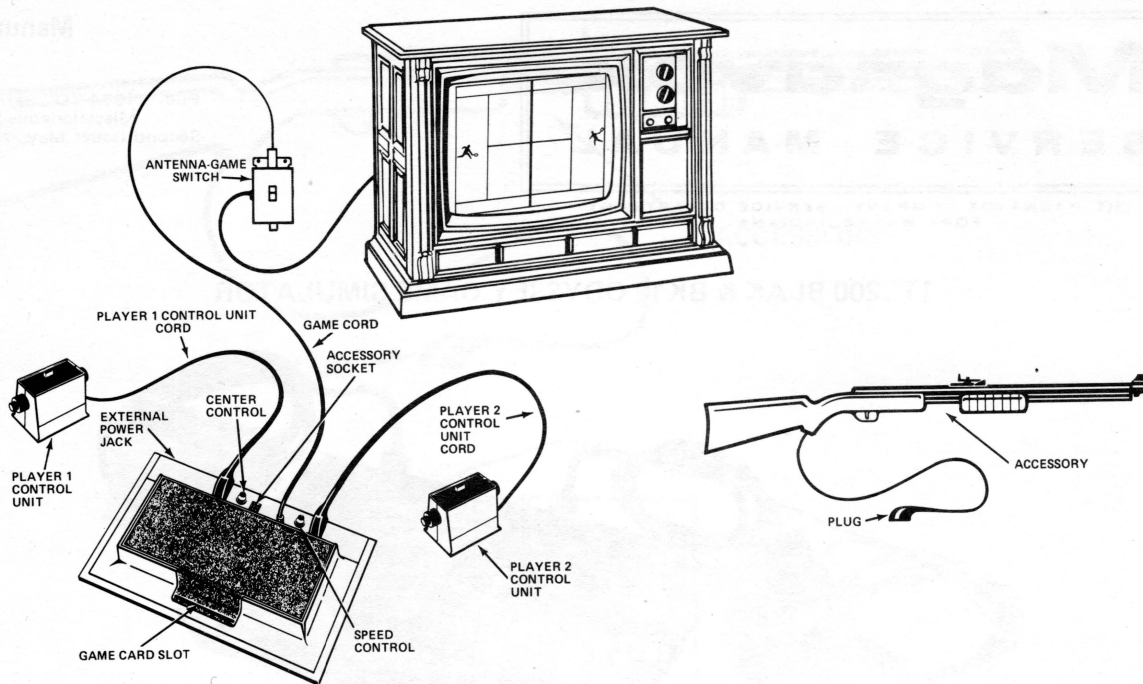

Figure 2 -- Odyssey Game Setup with Rifle Accessory

INSTALLATION INSTRUCTIONS

1. Plug the Player Control Unit cables into the Master Control Unit as illustrated in Figure 2. The two Player Control Units are identical; however, the Player Control Unit connected to the PLAYER 1 socket will be called Player Control Unit Number 1 and the one connected to the PLAYER 2 socket will be called Player Control Unit Number 2.
2. The GAME CORD is used to connect the Master Control Unit to the ANTENNA-GAME SWITCH. Insert one end of the GAME CORD into the socket marked GAME CORD on the Master Control Unit. The other end plugs into the socket on the top of the ANTENNA-GAME SWITCH marked GAME CORD.
3. The ANTENNA-GAME SWITCH is provided as a convenience to allow selection of either Odyssey or regular television viewing, without having to disturb antenna connections. After its initial installation, merely move the slide switch to either the GAME position for ODYSSEY . . . or to the TV position for television viewing.

Locate the VHF antenna terminals on the back of the television. Disconnect the VHF antenna cable (if there is one), and connect it to the ANTENNA-GAME SWITCH, as shown in the illustration. Connect the lead from the ANTENNA-GAME SWITCH to the VHF-300 terminals. When changing from GAME to TV, make certain the slide switch is moved to the extreme position; do not leave it in the middle.

Before proceeding further, set the ANTENNA-GAME SWITCH to the TV position and turn on television. Select a known operating channel and adjust television for normal picture viewing. If the TV incorporates a Remote System with Automatic Shut-Off, place the Remote Defeat Switch on the television in the "Off" position so the set does not turn off during testing.

Now, set the television to the VHF Channel (3 or 4) on which ODYSSEY will be displayed. Plug one end of the GAME CORD into the GAME CORD socket on the ANTENNA-GAME SWITCH and place the switch in the GAME position. Insert Game Card No. 1 for "Table Tennis" in the GAME CARD SLOT on the Master Control Unit and press down firmly until it is completely plugged in. The number 1 should be facing outward. The GAME CARD is also the power switch for the Master Control Unit so a signal is now being sent to the television receiver. It is, therefore, very important to remove the GAME CARD after playing, so that battery power is not depleted.

Look for a white vertical line from the top to bottom and possibly one or two small white squares. Adjust the VHF Fine Tuning on the television, if necessary, until this vertical line is straight and clear. Also, adjust the Brightness and Contrast controls for a bright white line against a dark gray background.

The CENTER CONTROL on the Master Control Unit should be adjusted until the vertical line is in the center of the television screen.

300 Ohm Lead-In

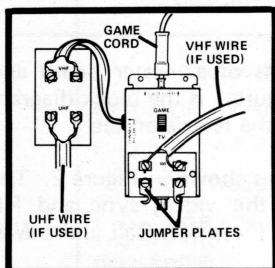

75 Ohm Coax Lead-In

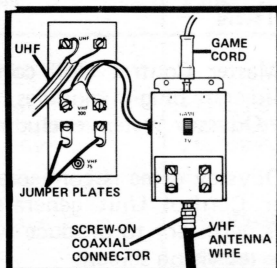

701517-1 "ANTENNA GAME SWITCH BOX" REPLACEMENT PARTS LIST

REF.	DESCRIPTION	PART NO.
	Strain Relief Bushing	102635-3
	Plastic Hook (2 used)	142712-1
	Antenna Connector, Male Coax	180739-1
	Antenna Connector, Female Coax	180902-3
	Antenna Switch Box	731913-5
	Antenna Switch Cover	731914-2
	TV/Game Switch	160499-1
S1	Balun	361000-8
T1	Balun	361485-1
T2	Balun	361485-1

CHECKOUT PROCEDURE

1. Visually inspect Master Control Unit, Player Control Units, and cables for breakage, cracks, broken or bent connector pins, broken wires, foreign material, corrosion or other damage.
2. Check to insure batteries are correctly installed.
3. Following the installation instructions on Page 2 connect Odyssey to a good TV receiver. Check Channel Switch setting in Odyssey battery compartment. Insert Game Card No. 1 in the Master Control Unit.
4. If there is no player image on the television screen when a Game Card is inserted in the Master Control Unit:
 - a. Rotate the HORIZONTAL and VERTICAL controls on both Player Control Units. If the Player images do not appear on the screen, continue with the check list.
 - b. Check to see that the Channel Selector on television is set to the proper channel (3 or 4), as indicated by the Channel Switch in the Master Control Unit.
 - c. Check to see that the Game Card is inserted properly with the number facing outward and is plugged in all the way.
 - d. Check to see that the Antenna-Game Switch is in the "Game" position and that the Antenna-Game Switch has been properly installed.
 - e. Check to see that the Game Cord is plugged into the socket provided on the top of the Antenna-Game Switch and on the back of the Master Control Unit.
 - f. Connect an external +9 volt power supply to J1. If unit now functions normally, replace all batteries with new ones. Insure that batteries are properly installed.

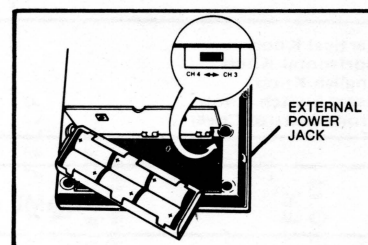

- g. Check to insure that the contacts of J1 close when external power plug is removed. If J1 contacts do not press together, bend one or the other until contact is made. Recheck operation with external power supply. J1 is accessible through the battery compartment.
5. If trouble is experienced with one or more games:
 - a. Check to be sure the proper Game Card is properly inserted in the Master Control Unit.
 - b. Check Game Card to see if there is any visible damage to the card.
 - c. If no Players, Ball, or Wall appear on the television screen, try a new Game Card.
 - d. If one Player does not appear or cannot be controlled, or if control of Ball by that Player Control Unit is abnormal, unplug the Player Control Units and switch them. If malfunction changes to other side, a Player Control Unit is defective and should be replaced.
 - e. In the event the preceding steps fail to locate the problem, the Master Control Unit should be repaired or replaced.
 - f. If the Unit operates normally except with accessories, check accessory connections. Test the Unit with new accessory. If the malfunction disappears, original accessory is defective; if not, replace Master Control Unit.

"CIRCUIT MODULES" REPLACEMENT PARTS LIST
 (Individual Parts with the Module are not available)

REF.	DESCRIPTION	PART NO.
	Horizontal Sync Generator Module	703491-3
	Vertical Sync Generator Module (BLAK)	703492-3
	Vertical Sync Generator Module (BK12)	703492-5
	Player No. 1 Generator Module (BLAK)	703493-2
	Player No. 1 Generator Module (BK12)	703493-3
	Player No. 2 Generator Module (BLAK)	703493-2
	Player No. 2 Generator Module (BK12)	703493-3
	Ball Generator Module (BLAK)	703493-2

REF.	DESCRIPTION	PART NO.
	Ball Generator Module (BK12)	703493-3
	Wall Generator Module (BLAK)	703493-2
	Wall Generator Module (BK12)	703493-3
	Flip-Flop/English Module	703494-2
	Flip-Flop/Ball Module	703494-2
	Gate Matrix Module (BLAK)	703495-2
	Gate Matrix Module (BK12)	703495-4
	Summer Module	703496-2
	RF Oscillator Module	703497-3
	RF Filter Module	703498-2
	Hand Control No. 1 & 2 Module (BLAK)	703488-2
	Hand Control No. 1 & 2 Module (BK12)	703488-3

701578-1 & 4 "PLAYER CONTROL" REPLACEMENT PARTS LIST

REF.	DESCRIPTION	PART NO.
	Vertical Knob	142695-1
	Horizontal Knob	142696-1
	English Knob	142697-4
	Reset Switch Knob	142828-1
	Front Control Cover	142706-1

REF.	DESCRIPTION	PART NO.
	Back Control Cover	142705-1
	Feet, Black (4 used)	141737-3
	Reset Switch	160487-1
S1	100K/25K, English/Horizontal	220272-3
R6A,B	50K, Vertical	220281-1
R8		

"GAME BOX" REPLACEMENT PARTS LIST

REF.	DESCRIPTION	PART NO.
	TABLE TENNIS	
	Game Card	142888-1
	Overlay (Medium)	151366-2
	Overlay (Large)	151367-2
	SKI	
	Game Card	142888-2
	Overlay (Medium)	151366-5
	Overlay (Large)	151367-5
	HOCKEY	
	Game Card	142888-3
	Overlay (Medium)	151366-3
	Overlay (Large)	151367-3
	Tape	642897-1
	FOOTBALL	
	Game Card	142888-4
	Overlay (Medium)	151366-4
	Overlay (Large)	151367-4
	Marker & Score Card	642964-1
	Board	642898-1
	Cards	701525-1
	SUBMARINE	
	Game Card	142888-5
	Overlay (Medium)	151366-6
	Overlay (Large)	151367-6
	ROULETTE	
	Game Card	142888-6
	Overlay (Medium)	151366-11
	Overlay (Large)	151367-11
	Chips	701528-1

REF.	DESCRIPTION	PART NO.
	SIMON SAYS	
	Overlay (Medium)	151366-8
	Overlay (Large)	151367-8
	Cards	701527-1
	HAUNTED HOUSE	
	Overlay (Medium)	151366-9
	Overlay (Large)	151367-9
	ANOLOGIC	
	Overlay (Medium)	151366-10
	Overlay (Large)	151367-10
	CAT & MOUSE	
	Overlay (Medium)	151366-12
	Overlay (Large)	151367-12
	STATES	
	Overlay (Medium)	151366-24
	Overlay (Large)	151367-24
	Map	591550-1
	Cards	701526-1
	Folder	591549-1
	MISCELLANEOUS	
	Operating Instruction Booklet	1B2622-3
	Battery (6 used)	530078-2
	Dice (2 used)	143018-1

703490-4 & 5 "MASTER" BOARD REPLACEMENT PARTS LIST

REF.	DESCRIPTION	PART NO.
	CAPACITORS	
C1	Electrolytic, 220 mfd., 10V	270111-2210
C2	Electrolytic, 47 mfd., 16V	270109-5115
C3	Electrolytic, 10 mfd., 35V	270109-1135
C4	Electrolytic, 47 mfd., 16V	270111-5115
C5	Electrolytic, 10 mfd., 35V	270109-1135
C6	Electrolytic, 100 mfd., 10V	270109-1210
C7	Electrolytic, 10 mfd., 35V	270109-1135
C8	Electrolytic, 4.7 mfd., 50V	270109-5050
C9	Electrolytic, 10 mfd., 35V	270109-1135
C10	Electrolytic, 4.7 mfd., 50V	270109-5050
C12	Electrolytic, 100 mfd., 10V	270109-1210
C14	Electrolytic, 470 mfd., 16V	270109-5215
C15	Electrolytic, 470 mfd., 16V	270109-5215
C21	Electrolytic, 47 mfd., 16V (BK 12 only)	270109-5115
	CONTROLS & SWITCHES	
R3	9K, Ball Speed	220166-44
R4	15K, Ball Height	220316-1533
R6	47K, Ball Width	220316-4733
R12	25K, Wall Center Adjust	220311-3
R17	47K, Wall Width	220317-4732
R26	47K, Player No. 1 Width	220316-4733
R28	15K, Player No. 1 Height	220316-1533
R31	15K, Player No. 2 Height	220316-1533
R32	47K, Player No. 2 Width	220316-4733
R38	47K, Horiz. Frequency Adjust	220300-4732
R39	100K, Vertical Freq. Adjust	220316-1043
S1	Channel Slide Switch	160498-1
	SEMICONDUCTORS	
D2	Silicon Diode	530072-1018
D3	Silicon Diode	530072-1018
D4	Silicon Diode	530072-1018
D5	Germanium Diode	530065-1002
D6	Germanium Diode	530065-1002

REF.	DESCRIPTION	PART NO.
D7	Germanium Diode	530065-1002
D8	Germanium Diode	530065-1002
D9	Silicon Diode (BK 12 only)	530072-1018
D10	Silicon Diode (BK 12 Only)	530072-1018
Z1	Zener Diode (6.2V) (BLAK Only)	530157-629
Z1	Zener Diode (6.8V) (BK 12 Only)	530157-689
Z2	Zener Diode (6.8V) (BLAK Only)	530157-689
Q1	NPN Silicon	610142-9
Q2	NPN Silicon	610142-9
Q3	NPN Silicon (BK 12 Only)	610142-9
SCR1	Thyristor	611003-1
	MISCELLANEOUS	
FB1 thru 4	Ferrite Bead	364005-1
TM1	Thermistor (BLAK Only)	230205-1
TM2	Thermistor (BLAK Only)	230205-2
J1	AC/DC Power Assembly	701479-4
	—Battery Connector	181096-1
	—Jack	181102-1
	—Terminals (2 used)	200451-2
J2	Edge Board Connector	181105-3
J3	12 Pin Female HSG Molex (Hand Control No. 2)	180727-2
J4	12 Pin Female HSG Molex (Hand Control No. 1)	180727-2
J5 thru		
J12	Module Socket	181069-1
J15 thru		
J17	Module Socket	181069-1
J18	Module Socket (RF Filter)	181069-2
J19	Phono Coax Socket	180902-4
J20	6 Pin Female HSG Molex (Rifle)	180732-1
	RF Shield Top	731906-1
	RF Shield, Bottom	731907-1
	RF Shield, Side	731908-1
	RF Spacer	642940-1
	AC External Adaptor (Optional Accessory)	2A9179

701477-3 & 5 "MASTER CONTROL" REPLACEMENT PARTS LIST

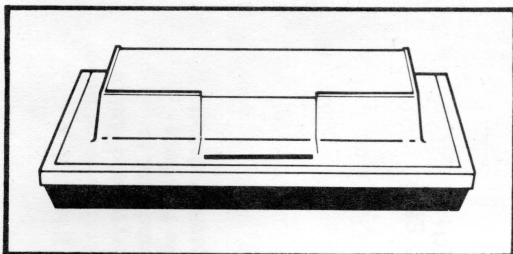

REF.	DESCRIPTION	PART NO.
	Knob, Speed & Center Control	141393-5
	Main Box, Top (BLAK)	142657-1
	Main Box, Top (BK12)	142657-3
	Main Box, Bottom	142659-3
	Battery Holder	142658-1
	Battery Door Cover	142693-1
	Door Spring	731965-1
	Door Button (2 used)	102631-4
	Feet, Black (4 used)	141737-3

The Master Control Unit contains a master board on which are mounted Game Card, Game Cord, Player, and accessory connectors, adjustment pots, and twelve plug-in modules. Field servicing of the Master Control Unit consists of isolating any malfunction down to a specific adjustment or defective module and making the appropriate adjustment or replacing the module.

Figure 3 shows the location and function of modules and adjustments on the master board. The adjustment potentiometers may be turned using a finger tip or screwdriver. The modules all plug vertically into sockets mounted on the board. To remove a module, grasp by the edges and gently lift one end out. If difficulty is encountered, use a small screwdriver to lift the plastic strip at the end of the socket to unlock the module.

SERVICE ADJUSTMENTS

CAUTION: UNDER NO CIRCUMSTANCES ATTEMPT TO MAKE ADJUSTMENTS OF THE RF OSCILLATOR AND RF FILTER LOCATED INSIDE THE METAL SHIELD. THESE ARE PRESET AT THE FACTORY IN TEST FIXTURES TO MAGNAVOX STANDARDS AND STRICT FCC REQUIREMENTS. IF RF CIRCUITS ARE DEFECTIVE REPLACE MODULES AND RETURN TO FACTORY.

IF REPLACEMENT OF MODULES IS NECESSARY BE SURE TO RESOLDER THE RF SHIELD COVER.

Potentiometers are provided on the master board to adjust sizes of the spots and frequencies of the vertical and horizontal sync generators. The adjustments may be made using the fingertip or a small screwdriver. Looking at the face of the potentiometer, clockwise rotation increases that function.

All adjustments are to be made with unit connected in accordance with the installation procedures. Fine tune and adjust Brightness and Contrast controls for best display. Use Game Card No. 1.

VERTICAL & HORIZONTAL FREQUENCY ADJUSTMENT

Vertical Freq. Adj. (Using a Frequency Counter)

1. Connect the Frequency Counter probe to TP2 (Vert. Test Point) and the ground of the probe to point W2.
2. Adjust R39 (Vert. Freq. Adj.) for 60 Hz ± 1 Hz.

Horizontal Freq. Adj. (Using a Frequency Counter)

1. Connect the Frequency Counter probe to TP3 (Horiz. Test Point) and the ground of the probe to point W2.
2. Adjust R38 (Horiz. Freq. Adj.) for 15,734 Hz. ± 50 Hz.

For Color Television

1. Select channel in high VHF.
2. Fine tune for best reception.

3. Place the Service switch in the middle or "Horizontal Frequency" position.
4. Adjust the TV Horizontal Hold control until the TV syncs with the broadcast sync.
5. Return the Service switch to "Normal" position.
6. Connect ODYSSEY Master Control unit to the TV.
7. Place the Channel Select switch in Channel 4 position and Game Card No. 2 into slot provided.
8. Place the Antenna/Game switch in the TV position. Tune TV to Channel 3 and Fine Tune for best reception. (If no signal is available on Ch. 3 use a Color Bar Generator to insure Ch. 3 is properly Fine Tuned. Turn Off generator after Fine Tuning the TV).
9. Place the Antenna/Game switch in the Game position. (If frequency is off the diagonal lines will be almost to the point of being horizontal).
10. Adjust R38 (located on the Master Board) until the horizontal lines are vertical. At this point the horizontal frequency is very close to the specified frequency.

For Monochrome Television

1. Select channel in high VHF.
2. Fine Tune for best reception.
3. Continue to Fine Tune into sound modulation where horizontal lines are evident.
4. Adjust the TV Horizontal Hold control until the horizontal lines are vertical and the horizontal blanking bar is vertical on the screen. (The Horizontal Hold control is now adjusted approximately +5 Hz. of the station sync.)

MASTER BOARD REFERENCE GUIDE (TOP VIEW)

6500-6

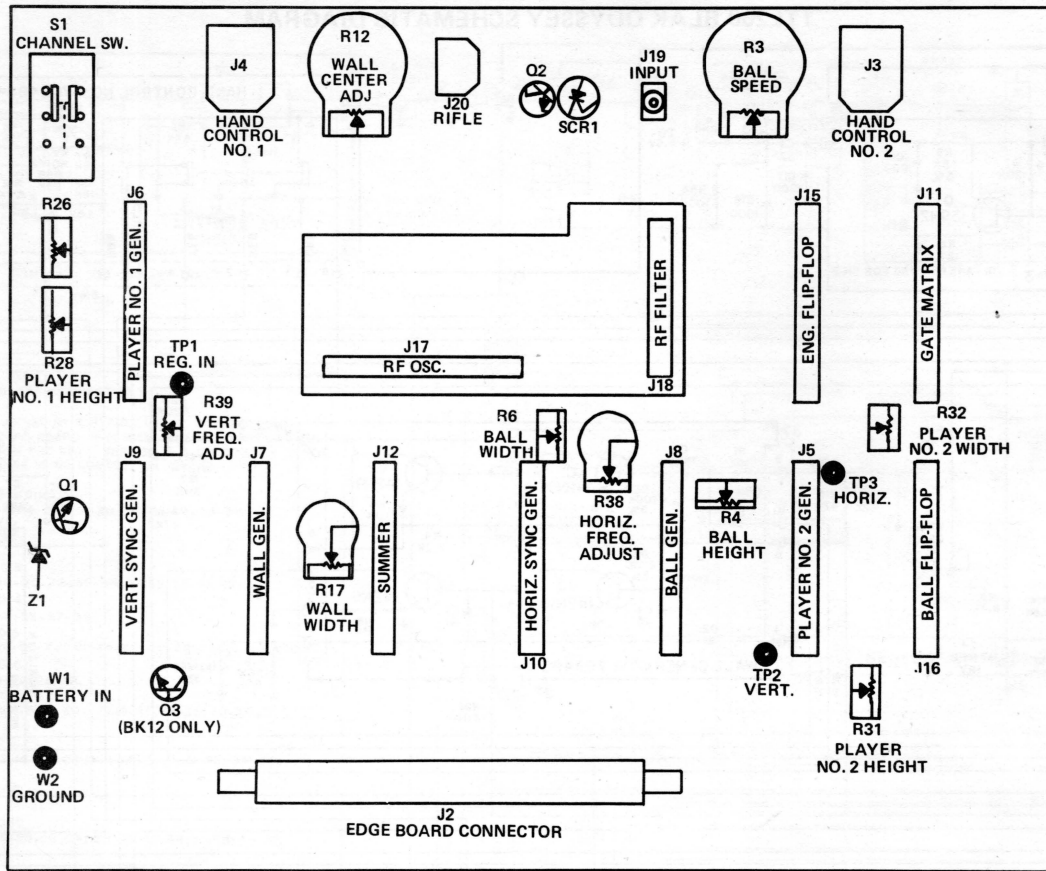
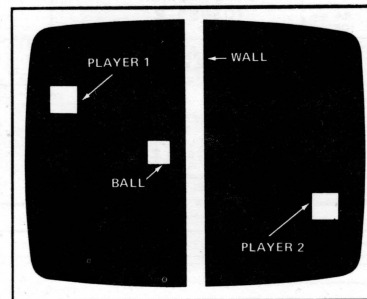

TABLE 1 -- SPOT SIZES

TV Tube Size	Wall Width	Player		Ball	
		Width	Height	Width	Height
25 in.	3/8 in.	1 1/4 in.	1 1/4 in.	1 in.	1 in.
23 in.	11/16 in.	1 1/8 in.	1 1/8 in.	7/8 in.	7/8 in.
21 in.	5/8 in.	1 in.	1 in.	7/8 in.	7/8 in.
19 in.	9/16 in.	15/16 in.	15/16 in.	3/4 in.	3/4 in.
16 in.	1/2 in.	13/16 in.	13/16 in.	5/8 in.	5/8 in.
14 in.	7/16 in.	11/16 in.	11/16 in.	9/16 in.	9/16 in.
12 in.	3/8 in.	5/8 in.	5/8 in.	1/2 in.	1/2 in.

Game Card No. 1 Display



SPOT SIZE ADJUSTMENTS

1. Adjust Player Control Units to position Player 1 on the left and Player 2 on the right side of the screen.
2. Use the Centering control (R12) to put the Wall at midpoint of the screen.
3. Table 1 shows the relative spot sizes in inches for various television picture tube sizes. Pick the size of the TV you are using or the listed size that is closest and the spot dimensions are listed on the same line. Use a ruler or tape to measure the spot size during adjustments.
4. Adjust R17 (Wall Width) until the Wall is the size shown in Table 1 (3/4 inch on 25 inch screen).
5. Adjust R26 (Player No. 1 Width) for proper width of Player No. 1.
6. Adjust R28 for Player No. 1 Height.
7. Adjust R32 for Player No. 2 Width.
8. Adjust R31 for Player No. 2 Height.
9. Depress both reset buttons and release. The Ball will drift to the center of the screen.
10. Turn the Centering control so that the Wall is not on top of the Ball.
11. Adjust R6 for Ball Width.
12. Adjust R4 for Ball Height.
13. Turn Centering Control (R12) so that the Wall is at midpoint on the screen.

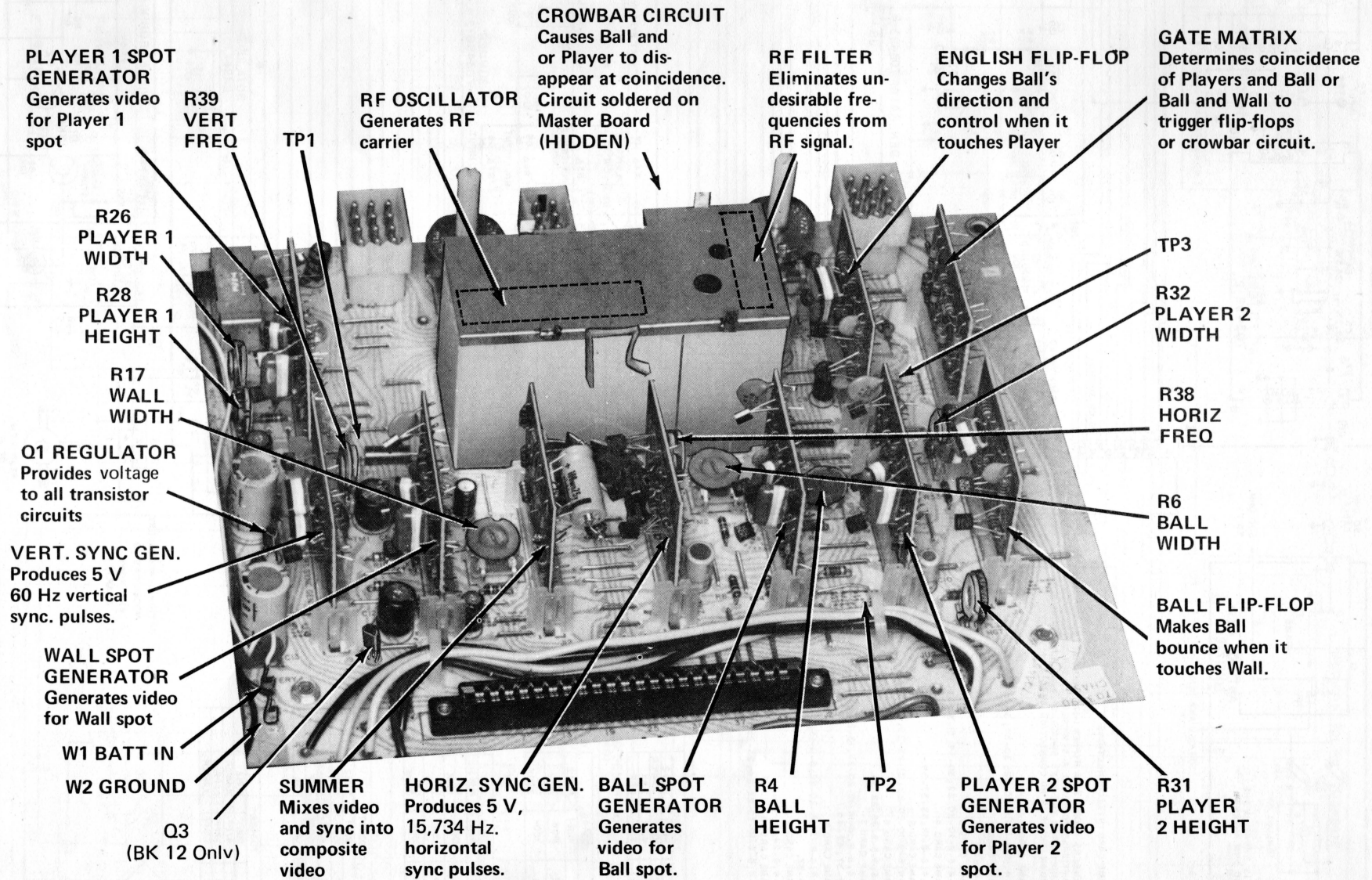
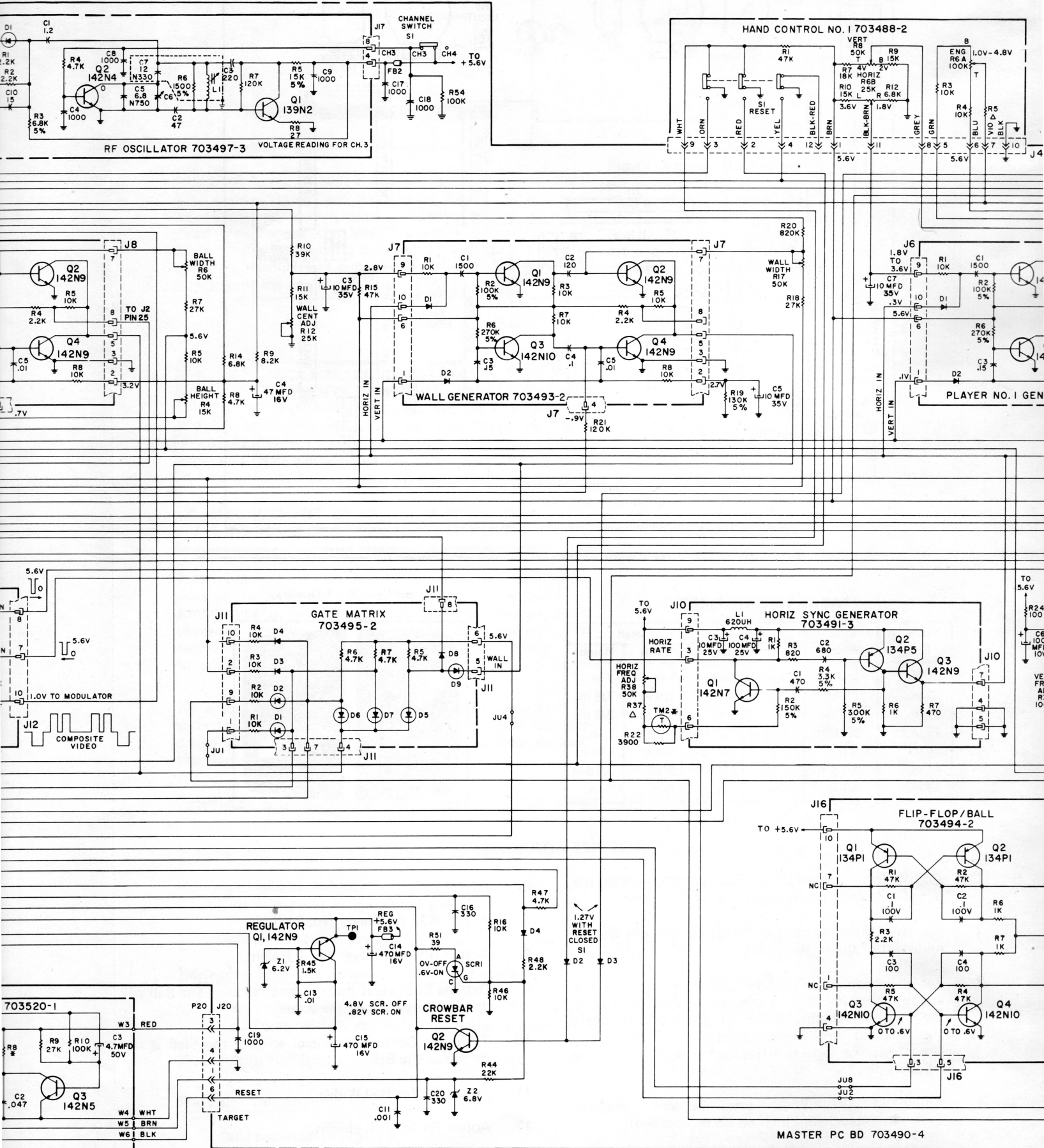
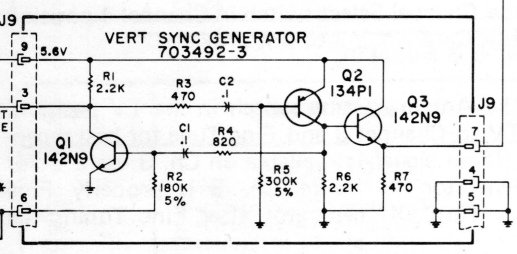
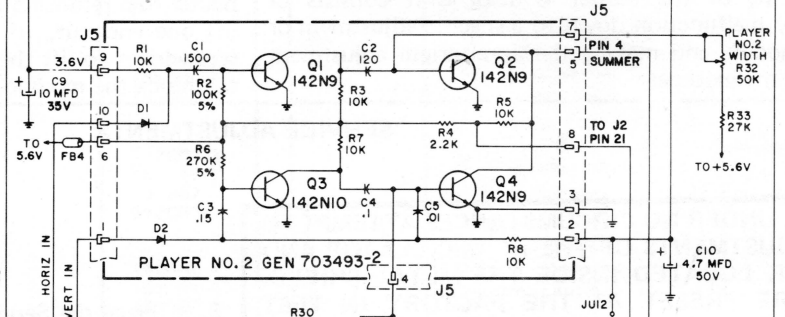
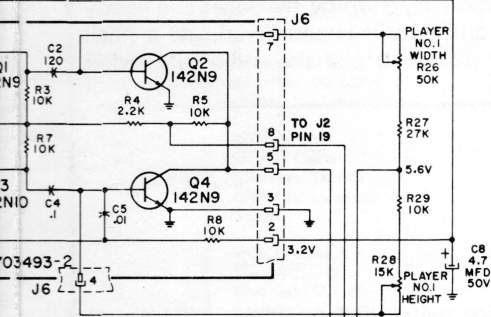
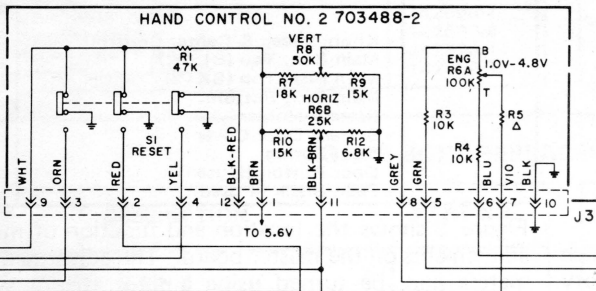

Figure 3 -- Master Board Module Location

1TL200 BLAK ODYSSEY SCHEMATIC DIAGRAM





- NOTES:
UNLESS OTHERWISE SPECIFIED
1. CAPACITANCE VALUES 1 OR GREATER ARE IN PICOFARADS.
 2. CAPACITANCE VALUES LESS THAN 1 ARE IN MICROFARADS.
 3. RESISTORS ARE 1/4 WATT, 10%.
 4. Δ = ADD JUMPERS WHERE PARTS INDICATED.
 5. * = SPACE PROVIDED ON LAYOUT, NO JUMPER.
 6. DIODES IN CIRCLES ARE GERMANIUM, OTHERS ARE SILICON.
 7. VOLTAGE READINGS TAKEN WITH CARD/ UNLESS OTHERWISE NOTED.
 8. VOLTAGE READINGS TAKEN WITH FLUKE DIGITAL VOLTMETER #8100 A.

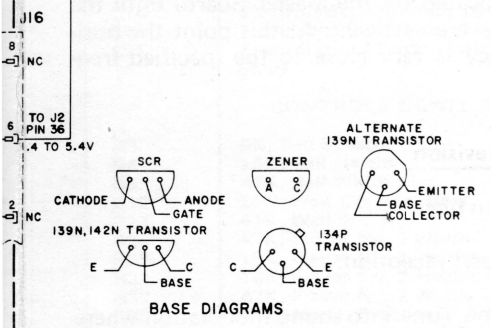
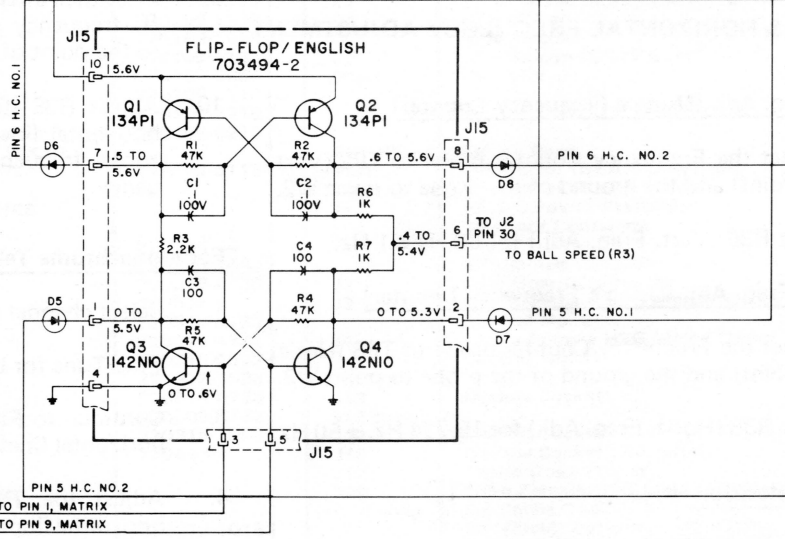

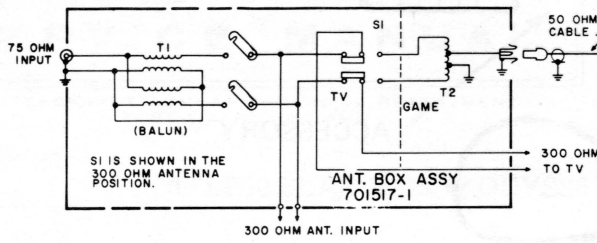

GAME CARD INTERCONNECTIONS

NUMBERS JOINED BY A HYPHEN (-) ARE CONNECTED ON GAME CARD PC BOARD. A SEMICOLON (;) SEPARATES EACH SERIES FROM THE NEXT SERIES. IF A PIN NUMBER IS NOT SHOWN, THERE IS NO CONNECTION AT THAT PIN.

- GAME CARD 1**
2-4; 6-8-14-16-20-22; 30-34; 31-39; 35-37.
- GAME CARD 2**
2-4; 6-8.
- GAME CARD 3**
2-4; 6-8-10-20-22; 30-34; 31-39; 35-37; 42-44.
- GAME CARD 4**
2-4; 6-8-10; 21-23; 33-37-39.
- GAME CARD 5**
2-4; 6-8-10-20-22; 21-23-25; 30-34; 31-33-39; 35-37.
- GAME CARD 6**
2-4; 3-5-9; 26-28-38.
- GAME CARD 7**
2-4; 6-8-10-14-16-20-22; 13-27; 23-25; 30-34; 31-39; 35-37; 42-44.
- GAME CARD 8**
2-4; 6-8-12-14-20-22; 9-11-13; 15-17; 31-39; 34-36; 38-37.
- GAME CARD 9**
2-4; 6-24; 21-23.
- GAME CARD 10**
2-4; 6-8-10-20-22-24; 23-25; 30-34; 31-39; 35-37.
- GAME CARD 11**
2-4; 6-8-12-14 20 22; 9-11-13; 15-17; 31-39; 34-36; 35-37; 38-40.
- GAME CARD 12**
2-4; 3-5-7; 6-8-18; 21-23; 26-28; 33-37-39.

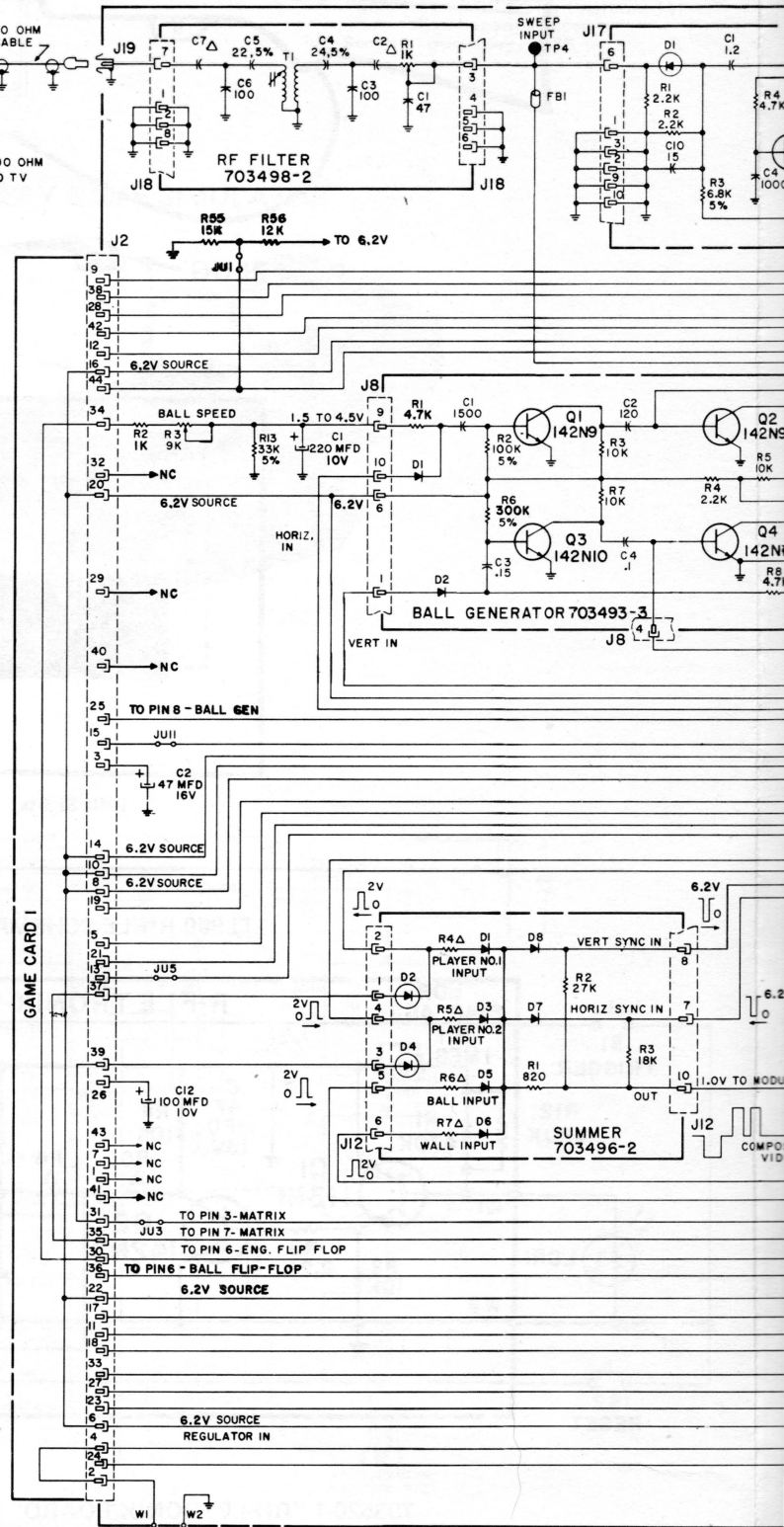

OPTIONAL ACCESSORY
MODEL 2A9179
EXT POWER
ADAPTOR

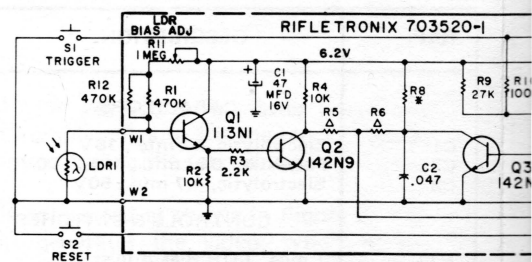
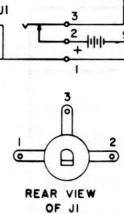

1TL200BK12 ODYSSEY SCHEMATIC DIAGRAM

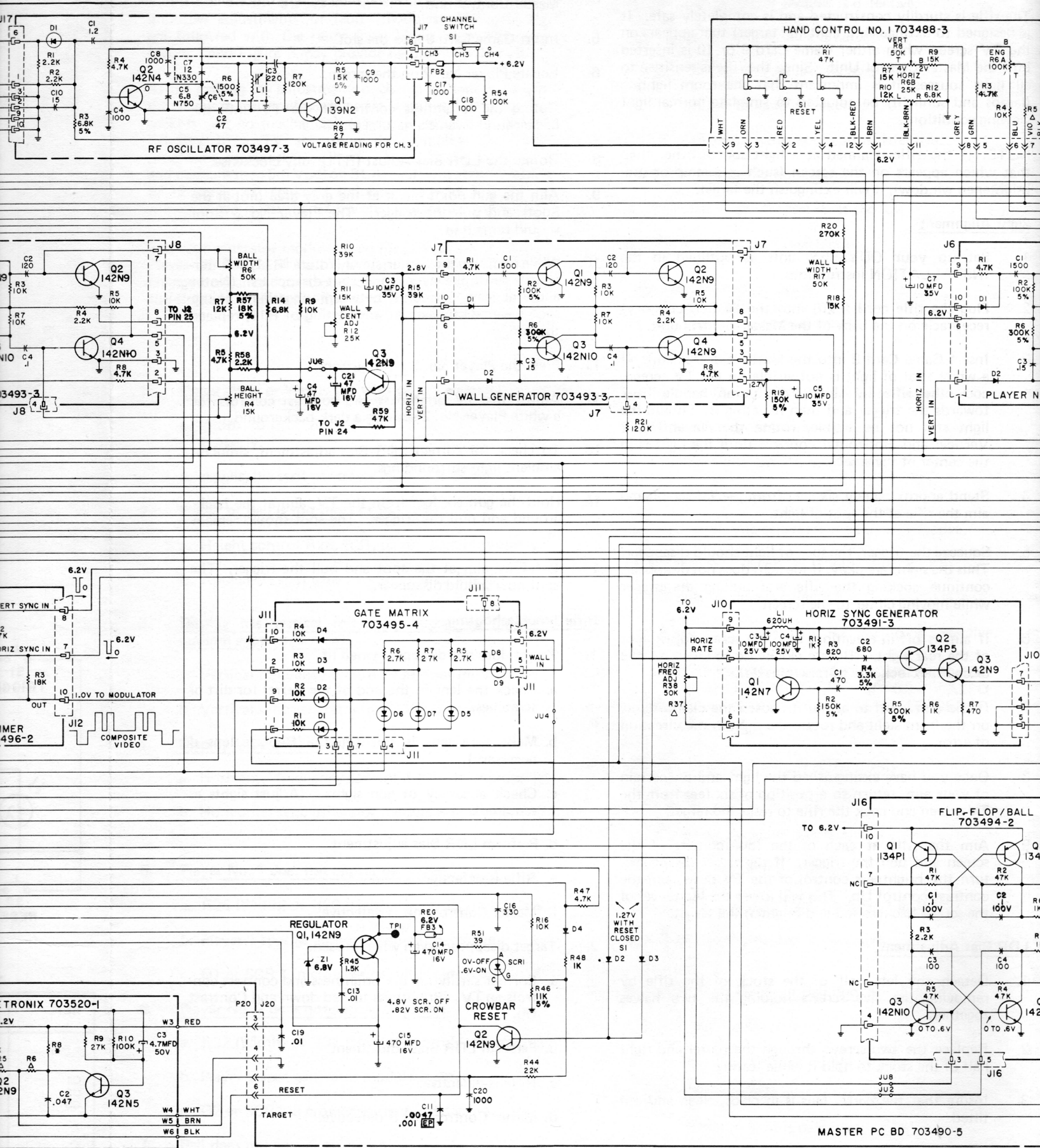

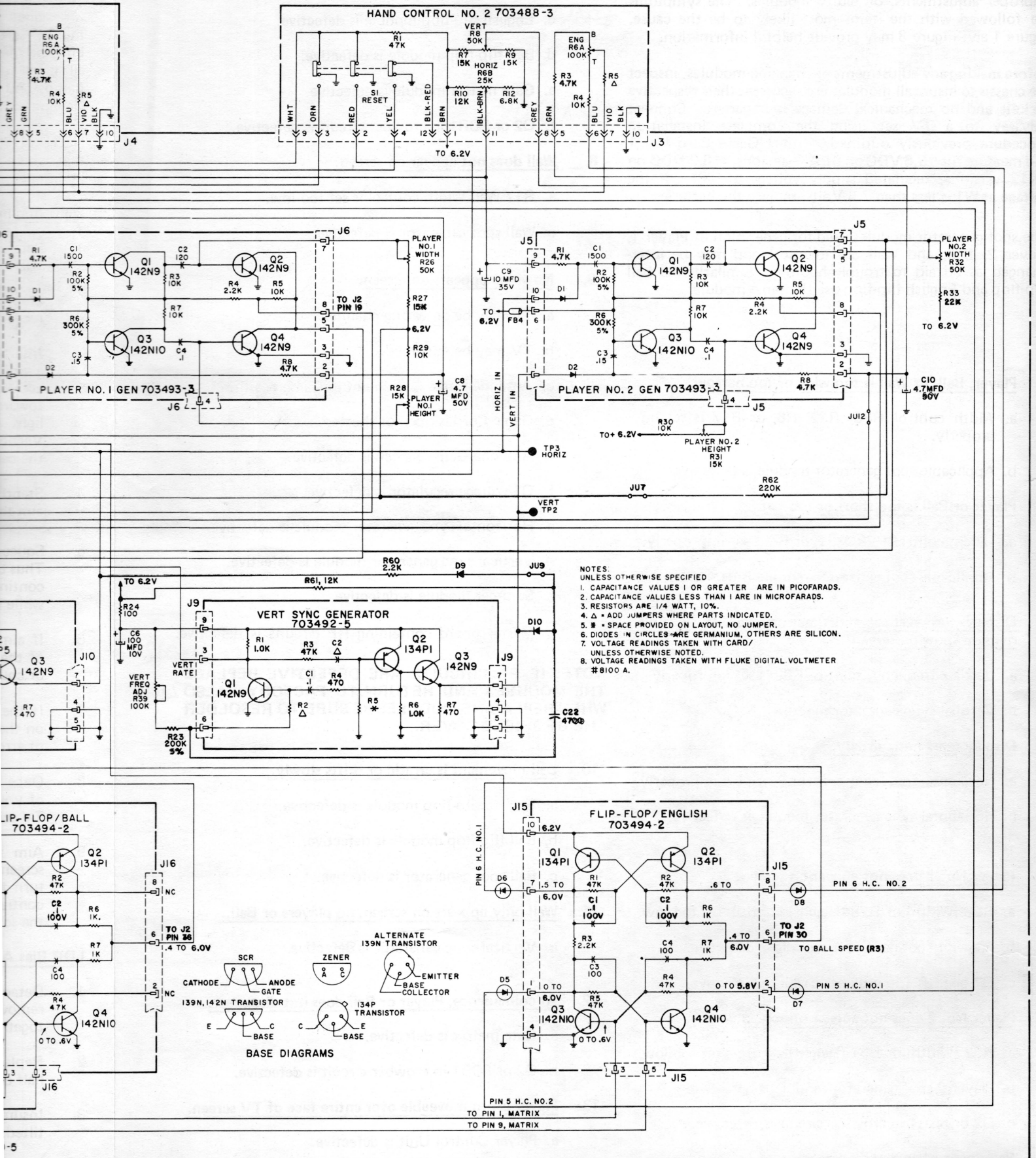

ODYSSEY TROUBLESHOOTING

This troubleshooting guide contains instructions for locating improper adjustments, or faulty modules. The symptoms are followed with the items most likely to be the cause. Figure 1 and Figure 3 may provide helpful information.

Before making any adjustments or changing modules, inspect the chassis to insure all modules are secure in their respective sockets and no mechanical damage is apparent. Connect Odyssey to a TV set using the complete installation procedure previously outlined. Insert Game Card No. 1 and measure the +5.6 VDC on BLAK versions, (+6.2 VDC on BK12 versions) regulated supply voltage at TP1. If the voltage at W1 is less than 7.5 Volts, replace the batteries.

The spot generator modules used for generation of Player 1, Player 2, Ball, and Wall are identical and may be interchanged as an aid to troubleshooting. Similarly the ball flip-flop and English flip-flop use the same module.

1. **Player, Ball, or Wall is too wide or too narrow.**
 - a. Width control R26, R32, R6, or R17 is set improperly.
 - b. Applicable spot generator module is defective.
 2. **Player or Ball is too short or too tall.**
 - a. Height control R28, R31, or R4 is set improperly.
 - b. Applicable spot generator module is defective.
 3. **Display has vertical roll (may appear as multiple random spots on screen).**
 - a. Vertical frequency control R39 is set improperly.
 - b. Vertical sync generator module is defective.
 4. **Display tears horizontally.**
 - a. Horizontal frequency control R38 is set improperly.
 - b. Horizontal sync generator module is defective.
 5. **Player No. 1 does not appear on screen.**
 - a. R26 (Width) or R28 (Height) controls set too low.
 - b. Player 1 spot generator module is defective.
 - c. Q1 or SCR 1 in crowbar circuit is defective.
 6. **Player No. 2 does not appear on screen.**
 - a. R32 (Width) or R31 (Height) controls set too low.
 - b. Player 2 spot generator module is defective.
 - c. Q2 or SCR1 in crowbar circuit is defective.
 7. **Ball does not appear on screen.**
 - a. R6 (Width) or R4 (Height) controls set too low.
 - b. Ball spot generator module is defective.
 - c. English flip-flop module is defective.
 - d. Ball flip-flop module is defective.
 - e. Gate matrix module is defective.
 - f. Q2 or SCR1 in crowbar circuit is defective.
 8. **Wall does not appear on screen.**
 - a. R17 Wall Width control is set too low.
 - b. Wall spot generator is defective.
 9. **No video appears on screen.**
 - a. TV may be on wrong channel.
 - b. TV may be mistuned.
 - c. Antenna-Game Switch not in Game position.
 - d. Game Cord is open or shorted.
 - e. Antenna-Game Switch is defective.
 - f. Q1 voltage regulator is defective.
 - g. Horizontal sync generator module is defective.
 - h. Vertical sync generator module is defective.
 - i. Summer module is defective.
 - j. Master board containing RF circuits is defective.
- NOTE: IF RF CIRCUITS ARE DEFECTIVE REPLACE THE MODULES AND RETURN TO FACTORY. ALSO WHEN REPLACING MODULES BE SURE TO RESOLDER THE RF SHIELD COVER.**
10. **Ball movement is erratic or drifts slowly.**
 - a. English flip-flop module is defective.
 - b. Ball flip-flop module is defective.
 - c. Ball spot generator is defective.
 11. **Wall only appears on screen, no players or Ball.**
 - a. Vertical sync generator is defective.
 12. **At coincidence, Player or Ball does not disappear.**
 - a. Gate matrix is defective.
 - b. Q2 or SCR1 in crowbar circuit is defective.
 13. **Player is not moveable over entire face of TV screen.**
 - a. Player Control Unit is defective.
 - b. Player spot generator module is defective.

1TL950 RIFLE ACCESSORY SERVICING

General Description

The rifle is sturdily constructed and is completely safe. It is designed to extinguish a light (or target) that appears on the TV screen when either Game Card 9 or 10 is inserted into the Master Control Unit. Since the rifle is sensitive to all light sources, it is important that the room lighting (lamps and sunlight) be adjusted to simulate normal light viewing conditions.

NOTE: If the rifle is aimed at a light source other than that which appears on the screen (such as a lamp or sun-brightened window), it will extinguish the target.

Sight Alignment

1. Set up your ODYSSEY unit as outlined in the INSTALLATION instructions.
2. Plug the rifle cord (P20) into the ACC (Accessory) receptacle on the back of the Master Control unit.
3. Insert Game Card 9 into the Master Control unit. If a white spot of light is not visible on the TV screen, cock the rifle by sliding the pump handle back towards the trigger and then releasing it. Should the light still not be visible, rotate the Player No. 2 Vertical and Horizontal controls until the light is in the center of the screen.
4. Stand approximately six feet from the TV screen and aim the rifle at the spot of light.
5. Squeeze the trigger, the spot of light should disappear. Thus the sights are okay. If the light does not disappear, continue cocking the rifle and pulling the trigger while moving closer to the screen.
6. If aim is off in elevation, turn the screw adjustment of the rear sight. (Rotate clockwise to lower muzzle or counterclockwise to raise muzzle).
7. If the aim is off in azimuth, loosen the clamp screw on the front sight and rotate the sight in the direction of error.
8. Once you have extinguished the light and are certain of your aim, return to a position of six feet from the TV screen and cock the rifle to reset the target.
9. Aim the rifle at each of the four corners of the screen and pull the trigger. If the target disappears, turn the brightness control of the TV down and the contrast control Up. This will lower the light level of the screen background and brighten the target.

LDR Bias Adjustment

1. Detach the left half of the stock of the rifle by removing the five screws holding the two halves together.
2. Replace the two screws through the barrel and right half of the stock to hold it while testing.
3. Insure that the barrel lens is in place, clean and not tilted.

4. Plug the rifle cord (P20) into the ACC jack on the Master Control unit.
5. Insert Game Card 9 into the slot.
6. Locate Player No. 2 on the screen.
7. Rotate the brightness control of the TV until the background level is a natural gray.
8. Rotate the LDR Bias Adjust (R11) fully clockwise.
9. Aim the gun point blank at the gray area (not at the Spot) and pull the trigger. The Player No. 2 Spot should remain lit.
10. While pumping the trigger, slowly rotate (R11) counterclockwise until Player No. 2 spot disappears. (Note: allow at least 2 seconds between triggering). If the spot never disappears at any setting of R11, replace the gun.
11. Press the Player No. 2 reset button.
12. Adjust the TV brightness and contrast controls for a white Player No. 2 spot on a dark background.
13. To check for correct LDR Bias adjustment, simulate ambient light surroundings.
14. Hold the gun six feet from the TV, aim at the background and pull the trigger. The spot should remain lit.
15. Carefully aim at the spot and pull the trigger. The spot now should disappear.

Rifle Troubleshooting

1. Target does not disappear when lit.
 - a. Check the lens in the end of the barrel for dirt or scratches.
 - b. Make sure lens is not tilted. (Replace lens if necessary).
 - c. Check accuracy of gun sights. (Adjust sights as required).
 - d. Perform LDR Bias adjustment.
 - e. Rifle is defective.
 - f. Master Control unit is defective.
2. Target disappears even when missed.
 - a. Correct setting of the brightness and contrast controls on TV. (Brightness turned down and Contrast Up).
 - b. Perform LDR Bias adjustment.
 - c. Rifle is defective.
 - d. Master Control unit is defective.

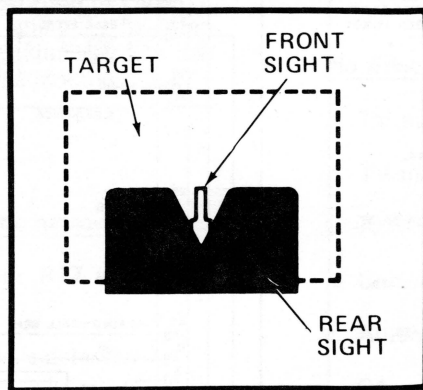
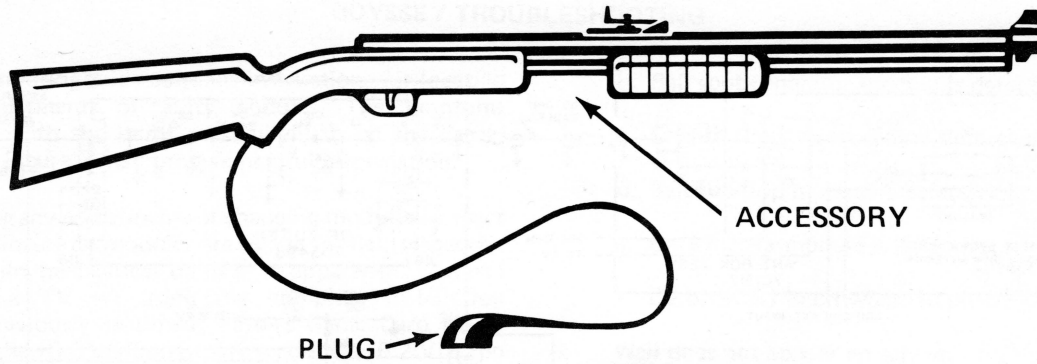

Rifle Sights

1TL950 RIFLE SCHEMATIC DIAGRAM

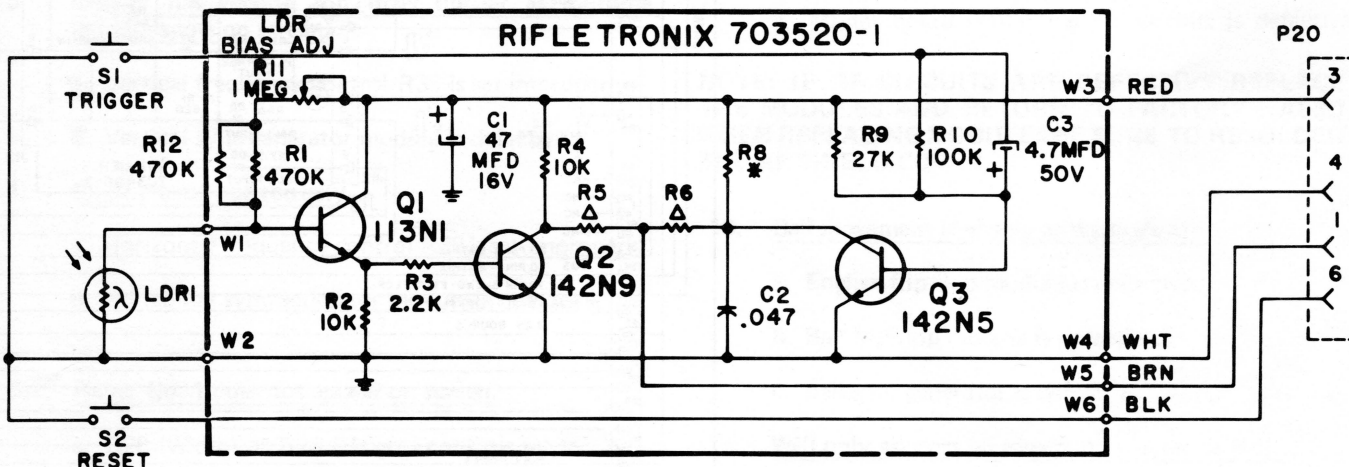

703520-1 "RIFLETRONIX BOARD" REPLACEMENT PARTS LIST

REF.	DESCRIPTION	PART NO.
CAPACITORS		
C1	Electrolytic, 47 mfd., 16V	270109-5115
C2	Polyester, .047 mfd., 10%, 100V	250581-4743
C3	Electrolytic, 4.7 mfd., 50V	270109-5050
CONTROLS & SWITCHES		
R11	1 meg., LDR Bias Adjust	220193-36
S1	Trigger Switch	731984-1
S2	Reset Switch	731985-1

REF.	DESCRIPTION	PART NO.
SEMICONDUCTORS		
Q1	NPN Silicon	610113-1
Q2	NPN Silicon	610142-9
Q3	NPN Silicon	610142-5
MISCELLANEOUS		
LDR1	Light Dependent Resistor	230204-2
	LDR Holder, Top	142722-1
	LDR Holder, Bottom	142723-1
	Wire Wrap Pin	200460-3