

Repair Document For Known Sony PVM CRT Issue

Published by S13G32

[Reddit](#) | [Website](#)

The purpose of this short document is to assist in the diagnosis and repair of the issues I found after obtaining a number of Sony PVM models of different types and years. These units all had the same issue which will be pictured and described below, I was unsuccessful in finding information easily on this issue thus I have created and distributed this document.

Many thanks to [Manualslib](#), [Datasheetz](#), [Mouser](#), [ON Semiconductor](#), and [Texas Instruments](#) for all schematics, documents, and parts used during this repair process.

Issue:

Power on, Tally light, No response from menu or input buttons, No picture display

PVM-1353MD/1453MD

SERVICE MANUAL

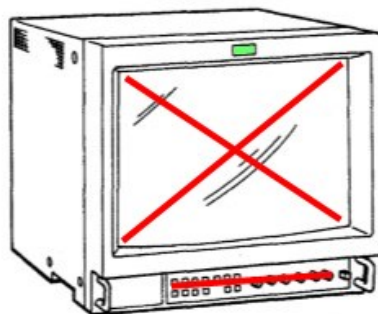

*US Model
Canadian Model*

PVM-1353MD
Chassis No. SCC-H31B-A

AEP Model

PVM-1453MD
Chassis No. SCC-H29C-A

Issue repaired on following models

PVM-1353MD, PVM-1351Q,

PVM-1343MD, PVM-14M4U

Within a short period of time I was able to get my hands on six PVM's that needed repair where three had the same issue as described while the others had other issues of similar nature.

I will start by saying that this issue is caused almost 100% of the time by an issue on the power board, otherwise notated as the G board for Sony PVM models, where power is not being delivered properly.

The culprit in my repair case was the same across all models I worked on, the G board was not outputting 5v over the "5V a" rail. At first I was haphazard and just did what everyone online was saying to do, replace the capacitors on the G board. Now, this is a really important thing to do overall with any PVM due to the high likelihood for the G board caps to fail.

After replacing all the caps on my G board for both my 1352MD and 1351Q models I was still getting the failure. I went through and checked all the caps again with my Woods multimeter which has served me well for years now. I urge you to use an electronic multimeter for this repair due to being easier to read outputs off the G board and the more options you will typically get from it. A fluke meter was my weapon of choice and did a great job of reading all the power rails that I needed it to.

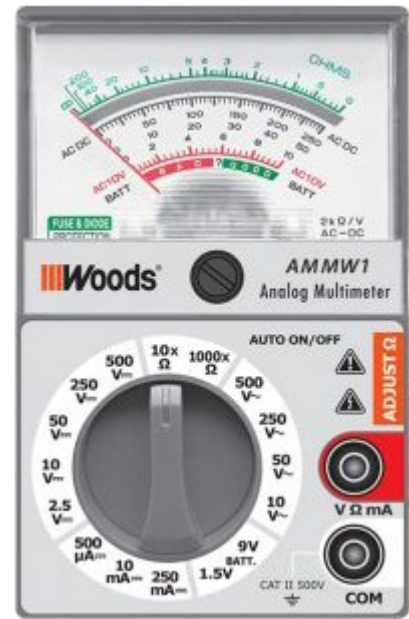

Woods Multimeter



Fluke 115 Multimeter

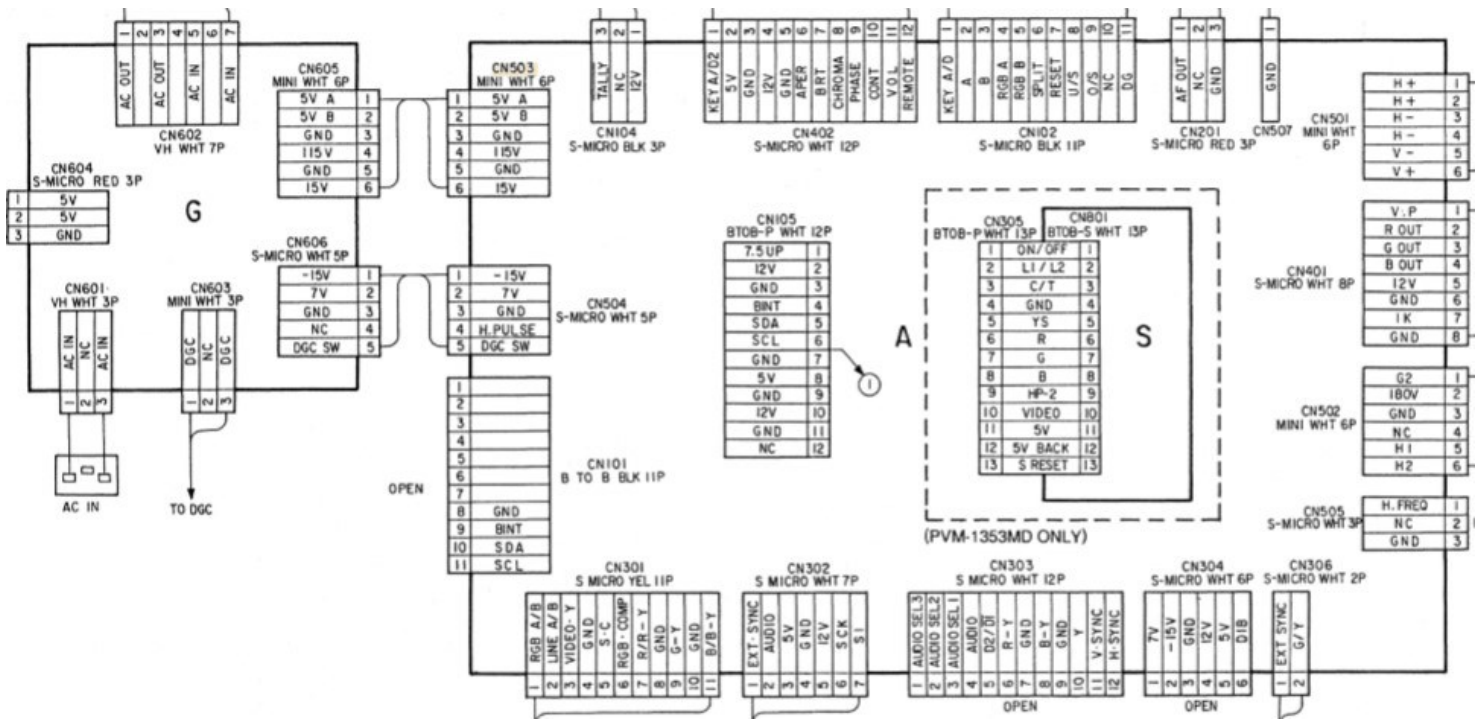

Schematic diagram of connections between G board and A board for PVM-1353MD

Above you can see the diagram showing the connection between the G board and A board at CN605 (g board) & CN503 (a board) in it's simplest format. The connection that we are engaging with is that "5V a" rail on connection 1.

To test this in the most easy and safest ways, unplug the G board's connection from the A board, flip the G board over and find the CN605 connection. You will see the silkscreen printing for all the rails we are interested in on the backside of the board easily.

Ensure that power is plugged into the unit and use the power switch to activate all the rails on the G board. Do be mindful and careful not to touch or move the board at random due to the high voltage going through it.

Use the multimeter to test the CN605 connections for the "5V a", "5V b", "15V", and "115V" rails. You should be getting readings within 1V of each indicated connection.

After testing all the power rails on the G board and finding that "5V a" is actually not outputting anything near 5V you can follow the traces down the line and find the culprit. For myself the problem child on the G board was IC603, an integrated circuit voltage regulator.

This part takes 10V and converts it down to 5V and can easily overheat and burn out after years of use. This 5V line is important for the PVM due to being the power source for IC502 and IC503 on the A board.

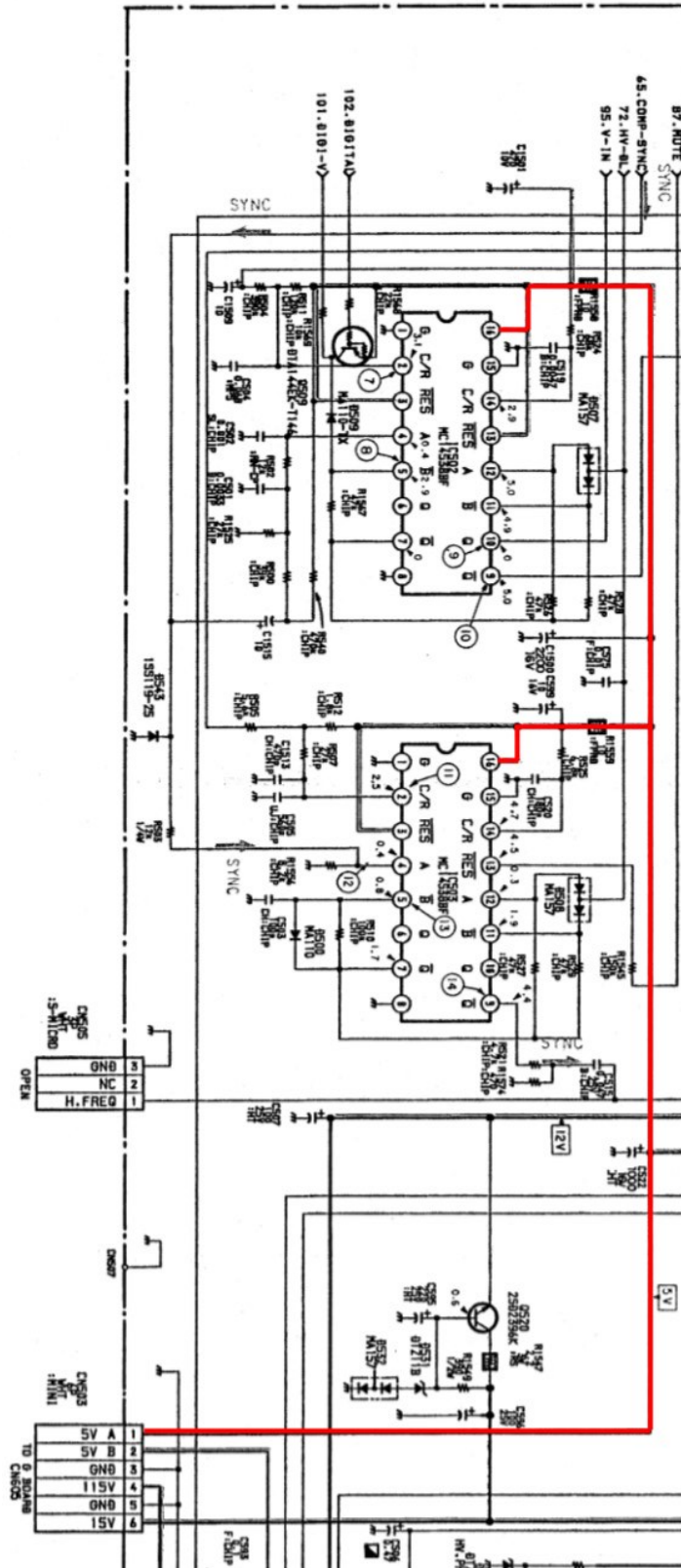

In Conclusion

If "5V a" is not outputting 5V -> Replace IC603 on G board

If "5V b" is not outputting 5V -> Replace IC604 on G board, Do check schematics and the actual board to confirm that IC604 is handling the "5V b" rail. IC604 handled "5V b" on my boards though the schematics do not reflect that.

Part# from Schematics:

8-759-701-5

Mouser Part#:

513-NJM78M05FA

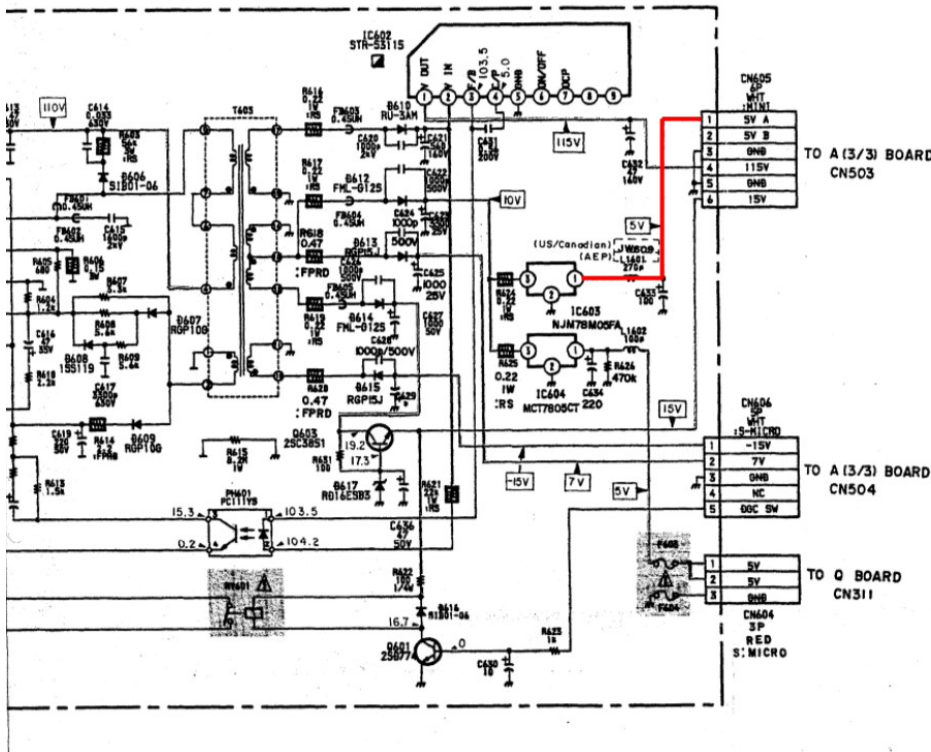
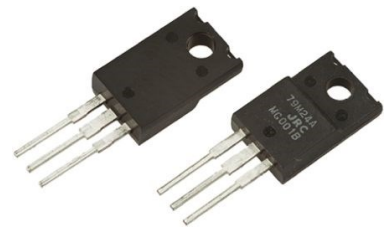

G BOARD

IC601	REF PWM
IC602	+B CONTROL
IC603	+5V A REG
IC604	+5V B REG
Q601	RELAY DRIVE
Q603	+15V REG
D601	MAIN RECT
D602	MAIN RECT
D603	MAIN RECT
D604	MAIN RECT
D605	OVP
D606	PROTECT
D607	SWITCH
D608	SWITCH
D609	SWITCH
D610	+B RECT
D612	+12V RECT
D613	+7V RECT
D614	+15V RECT
D615	-15V RECT
D616	PROTECT
D617	REF VOLTEGE

For anyone curious about IC502 & IC503

A (3/3) BOARD

IC200	AUDIO OUT
IC500	X-RAY PROTECT
IC502	V DELAY MONO-MULTI
IC503	H DELAY MONO-MULTI
IC504	V GAIN-CONT AMP 2
IC505	+12V REG
IC506	H BLK MONO-MULTI
IC507	DEFLECTION
IC508	V GAIN-CONT AMP 1
IC509	PIN COMPLETION
IC510	16:9 V BLK MONO-MULTI

IC413	8-759-932-67	IC BU4053BCF
IC500	8-749-010-07	IC H8D7248
IC502	8-759-009-51	IC MC14538BF
IC503	8-759-009-51	IC MC14538BF
IC504	8-752-053-21	IC CXA1211M

MC14538B

Dual Precision Retriggerable/Resettable Monostable Multivibrator

Both IC502 & IC503 are timing chips used for the vertical sync & horizontal sync. Without power going to these chips, the unit is unable to compile or understand the sync input and display an image.

Description

CD14538B dual precision monostable multivibrator provides stable retriggerable/resettable one-shot operation for any fixed-voltage timing application.

An external resistor (R_X) and an external capacitor (C_X) control the timing and accuracy for the circuit. Adjustment of R_X and C_X provides a wide range of output pulse widths from the Q and \bar{Q} terminals. The time delay from trigger input to output transition (trigger propagation delay) and the time delay from reset input to output transition (reset propagation delay) are independent of R_X and C_X . Precision control of output pulse widths is achieved through linear CMOS techniques.

Leading-edge-triggering (+TR) and trailing-edge-triggering (-TR) inputs are provided for triggering from either edge of an input pulse. An unused +TR input should be tied to V_{SS} . An unused -TR input should be tied to V_{DD} . A RESET (on low level) is provided for immediate termination of the output pulse or to prevent output pulses when power is turned on. An unused RESET input should be tied to V_{DD} . However, if an entire section of the CD14538B is not used, its inputs must be tied to either V_{DD} or V_{SS} . See Table 1.

In normal operation the circuit retriggers (extends the output pulse one period) on the application of each new trigger pulse. For operation in the non-retriggerable mode, \bar{Q} is connected to -TR when leading-edge triggering (+TR) is used or Q is connected to +TR when trailing-edge triggering (-TR) is used. The time period (T) for this multivibrator can be calculated by: $T = R_X C_X$.

The minimum value of external resistance, R_X , is 4 k Ω . The minimum and maximum values of external capacitance, C_X are 0 pF and 100 μ F, respectively.

The CD14538B is interchangeable with type MC14538 and is similar to and pin-compatible with the CD4098B* and CD4538B. It can replace the CD4538B which type is not recommended for new designs.

The CD14538B types are supplied in 16-lead hermetic dual-in-line ceramic packages (F3A suffix), 16-lead dual-in-line plastic packages (E suffix), 16-lead small-outline packages (M, M96, MT, and NSR suffixes), and 16-lead thin shrink small-outline packages (PW and PWR suffixes).

Features

- Retriggerable/resettable capability
- Trigger and reset propagation delays independent of R_X , C_X
- Triggering from leading or trailing edge
- Q and \bar{Q} buffered outputs available
- Separate resets
- Replaces CD4538B Type
- Wide range of output-pulse widths
- Schmitt-trigger input allows unlimited rise and fall times on +TR and -TR inputs
- 100% tested for maximum quiescent current at 20 V
- Maximum input current of 1 μ A at 18 V over full package-temperature range; 100 nA at 18 V and 25°C
- Noise margin (full package-temperature range):
 - 1 V at $V_{DD} = 5$ V
 - 2 V at $V_{DD} = 10$ V
 - 2.5 V at $V_{DD} = 15$ V
- 5-V, 10-V, and 15-V parametric ratings
- Standardized, symmetrical output characteristics
- Meets all requirements of JEDEC Tentative Standard No. 13B, "Standard Specifications for Description of 'B' Series CMOS Devices"
- Applications:
 - Pulse delay and timing
 - Pulse shaping

*T = 0.5 $R_X C_X$ for $C_X \geq 1000$ pF

#T = $R_X C_X$; C_X min = 5000 pF

Data sheet acquired from Harris Semiconductor

In Conclusion

After replacing the IC603 on the G boards I was able to power the units on and feed image to them without any issues. My power boards were in amazing condition with no caps showing issues and almost no dust, these units were very clean on the inside. I will say that long period testing after completing the repair should be done to ensure there is not anything else wrong with the unit.

Recaps of the G board are highly recommended to prolong the unit's life.

I do hope that this simple document was of assistance to anyone having a similar issue that I was having.

I do stress to all individuals to be very careful when opening and repairing CRT units do to the amount of current they produce, please follow all possible safety methods to avoid injury or death!



Best wishes and good luck!