

## Display

Date: **August 29, 1994**

Subject: **ELECTROLYTIC CAPACITOR  
REPLACEMENT—GA BOARD**

Model: **BVM-1310/1311/1315/1316/1316C  
BVM-1910/1911/1912/1915/1916/2811**

Serial No: **SEE TEXT**

### DESCRIPTION

To improve reliability of the power block, replacement of the following electrolytic capacitors on the GA board may be necessary. (See Figure 1.)

- C1, C2, C64, C65 (1-124-024-00, 4.7 $\mu$ F, 350V)
- C8, C10 (1-124-525-11, 1000 $\mu$ F, 25V)

### Models/Applicable Serial Numbers

BVM-1310	2,002,231–2,002,250
BVM-1311	2,000,001–2,000,150 2,000,406–2,000,460 2,000,486–2,000,495 2,000,506–2,000,535
BVM-1315	2,002,061–2,002,243
BVM-1316	2,000,051–2,000,120 2,000,421–2,000,490 2,000,501–2,000,550
BVM-1316C	2,000,001–2,000,300 2,000,501–2,000,550
BVM-1910	2,002,231–2,002,270
BVM-1911	2,000,051–2,000,170 2,000,466–2,000,615 2,000,741–2,000,755
BVM-1912	2,000,214–2,000,216
BVM-1915	2,000,501–2,000,533
BVM-1916	2,000,051–2,000,080 2,000,276–2,000,325 2,000,336–2,000,360
BVM-2811	2,000,021–2,000,025 2,000,031–2,000,035 2,000,046–2,000,060

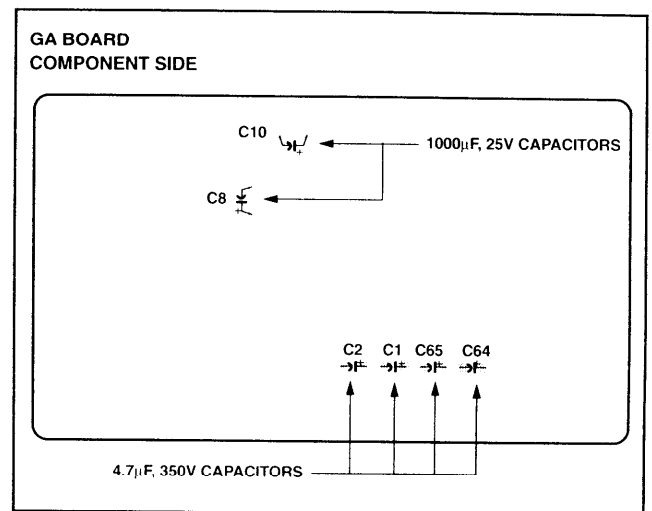

**Figure 1**

### Capacitors C1, C2, C64 and C65

1. Check lot numbers of C1, C2, C64 and C65. (See Figure 2.)
2. If capacitor with lot number "27B" is mounted, replace it with a new one.

### Capacitors C8, C10

3. Check the manufacturer of C8 and C10.
4. If C8 or C10 is not manufactured by Nippon Kemikon<sup>®</sup>, Rubycon<sup>®</sup> or ELNA<sup>®</sup>, replace it with a new one.

Figure 3 shows where the lot number is located on the capacitor.

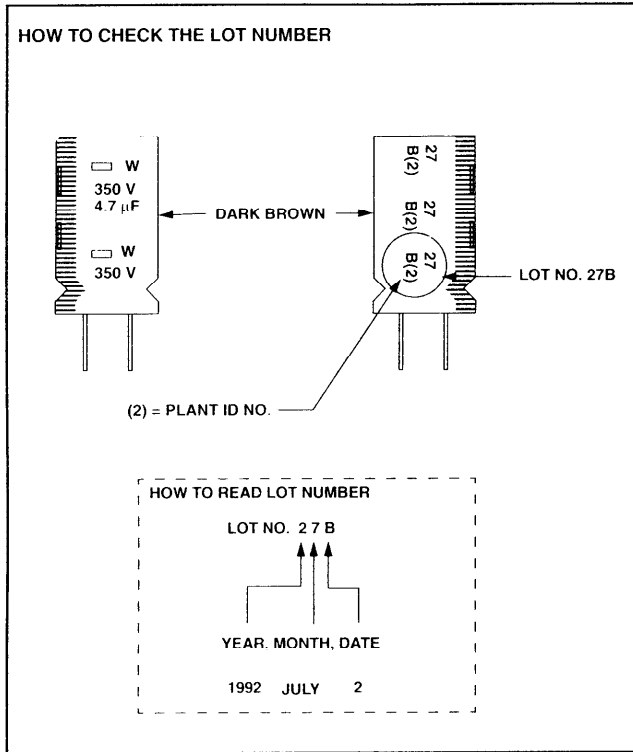

Figure 2

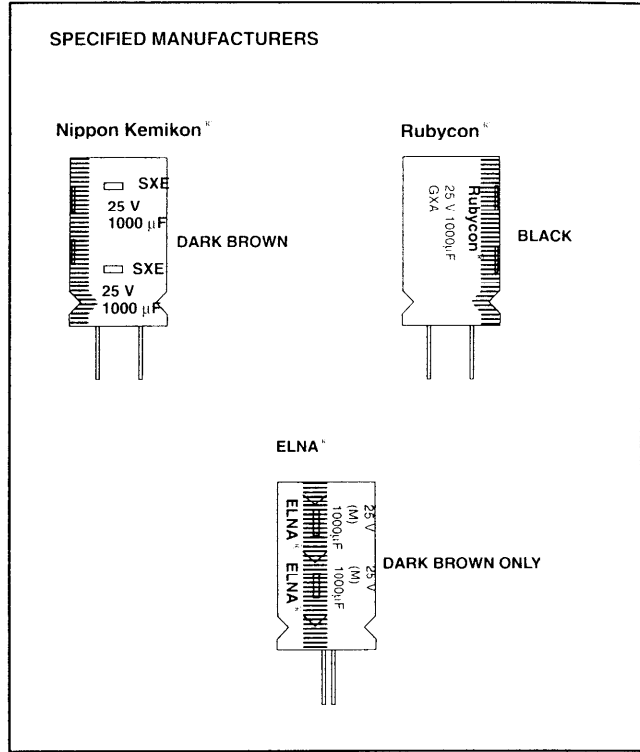

Figure 3