

# Professional Video Monitor

## Operating Instructions

Before operating the unit, please read this manual thoroughly and retain it for future reference.

**BVM-E251**

**BVM-E171**

Software Version 1.0

# TRIMASTER EL HDMI

## Owner's Record

The model and serial numbers are located at the rear. Record these numbers in the spaces provided below. Refer to these numbers whenever you call upon your Sony dealer regarding this product.

Model No. \_\_\_\_\_  
Serial No. \_\_\_\_\_

### Important Safety Instructions

- Read these instructions.
- Keep these instructions.
- Heed all warnings.
- Follow all instructions.
- Do not use this apparatus near water.
- Clean only with dry cloth.
- Do not block any ventilation openings. Install in accordance with the manufacturer's instructions.
- Do not install near any heat sources such as radiators, heat registers, stoves, or other apparatus (including amplifiers) that produce heat.
- Do not defeat the safety purpose of the polarized or grounding-type plug. A polarized plug has two blades with one wider than the other. A grounding-type plug has two blades and a third grounding prong. The wide blade or the third prong are provided for your safety. If the provided plug does not fit into your outlet, consult an electrician for replacement of the obsolete outlet.
- Protect the power cord from being walked on or pinched particularly at plugs, convenience receptacles, and the point where they exit from the apparatus.
- Only use attachments/accessories specified by the manufacturer.
- Use only with the cart, stand, tripod, bracket, or table specified by the manufacturer, or sold with the apparatus.  When a cart is used, use caution when moving the cart/apparatus combination to avoid injury from tip-over.
- Unplug this apparatus during lightning storms or when unused for long periods of time.
- Refer all servicing to qualified service personnel. Servicing is required when the apparatus has been damaged in any way, such as power-supply cord or plug is damaged, liquid has been spilled or objects have fallen into the apparatus, the apparatus has been exposed to rain or moisture, does not operate normally, or has been dropped.

## WARNING

**To reduce the risk of fire or electric shock, do not expose this apparatus to rain or moisture.**

**To avoid electrical shock, do not open the cabinet. Refer servicing to qualified personnel only.**

**THIS APPARATUS MUST BE EARTHED.**

### WARNING

When installing the unit, incorporate a readily accessible disconnect device in the fixed wiring, or connect the power plug to an easily accessible socket-outlet near the unit. If a fault should occur during operation of the unit, operate the disconnect device to switch the power supply off, or disconnect the power plug.

### WARNING

The apparatus shall not be exposed to dripping or splashing. No objects filled with liquids, such as vases, shall be placed on the apparatus.



This symbol is intended to alert the user to the presence of uninsulated "dangerous voltage" within the product's enclosure that may be of sufficient magnitude to constitute a risk of electric shock to persons.



This symbol is intended to alert the user to the presence of important operating and maintenance (servicing) instructions in the literature accompanying the appliance.

### CAUTION

The unit is not disconnected from the AC power source (mains) as long as it is connected to the wall outlet, even if the unit itself has been turned off.

### CAUTION:

Do not let children use the unit.

### BVM-E251 only

When installing the installation space must be secured in consideration of the ventilation and service operation.

- Do not block the ventilation slots, and vents of the fans.
- Leave a space around the unit for ventilation.
- Leave more than 40 cm of space in the rear of the unit to secure the operation area.

When the unit is installed on the desk or the like, leave at least 1U (4.4cm) or more of space above and below the

unit. Leaving 40 cm or more of space above the unit is recommended for service operation.

### **BVM-E171 only**

#### **Attention-when the product is installed in Rack:**

##### **1.Prevention against overloading of branch circuit**

When this product is installed in a rack and is supplied power from an outlet on the rack, please make sure that the rack does not overload the supply circuit.

##### **2.Providing protective earth**

When this product is installed in a rack and is supplied power from an outlet on the rack, please confirm that the outlet is provided with a suitable protective earth connection.

##### **3.Internal air ambient temperature of the rack**

When this product is installed in a rack, please make sure that the internal air ambient temperature of the rack is within the specified limit of this product.

##### **4.Prevention against achieving hazardous condition due to uneven mechanical loading**

When this product is installed in a rack, please make sure that the rack does not achieve hazardous condition due to uneven mechanical loading.

##### **5.Install the equipment while taking the operating temperature of the equipment into consideration**

For the operating temperature of the equipment, refer to the specifications of the Operation Manual.

##### **6.When performing the installation, keep the following space away from walls in order to obtain proper exhaust and radiation of heat.**

**Lower, Upper : 4.4 cm (1 3/4 inches) or more**  
**Right, Left : 1.0 cm (13/32 inches) or more**

The ventilation should not be impeded by covering the ventilation openings with items, such as newspapers, table-cloths, curtains, etc.

No naked flame sources, such as lighted candles, should be placed on the apparatus.

**WARNING:** THIS WARNING IS APPLICABLE FOR USA ONLY.

If used in USA, use the UL LISTED power cord specified below.

**DO NOT USE ANY OTHER POWER CORD.**

Plug Cap	Parallel blade with ground pin (NEMA 5-15P Configuration)
Cord	Type SJT or SVT, three 16 or 18 AWG wires
Length	Minimum 1.5 m (4 ft 11 in), Less than 2.5 m (8 ft 3 in)
Rating	Minimum 10A, 125V

Using this unit at a voltage other than 120V may require the use of a different line cord or attachment plug, or both. To reduce the risk of fire or electric shock, refer servicing to qualified service personnel.

**WARNING:** THIS WARNING IS APPLICABLE FOR OTHER COUNTRIES.

1. Use the approved Power Cord (3-core mains lead) / Appliance Connector / Plug with earthing-contacts that conforms to the safety regulations of each country if applicable.
2. Use the Power Cord (3-core mains lead) / Appliance Connector / Plug conforming to the proper ratings (Voltage, Ampere).

If you have questions on the use of the above Power Cord / Appliance Connector / Plug, please consult a qualified service personnel.

#### **For the customers in the U.S.A.**

This equipment has been tested and found to comply with the limits for a Class A digital device, pursuant to part 15 of the FCC Rules. These limits are designed to provide reasonable protection against harmful interference when the equipment is operated in a commercial environment. This equipment generates, uses and can radiate radio frequency energy and, if not installed and used in accordance with the instruction manual, may cause harmful interference to radio communications. Operation of this equipment in a residential area is likely to cause harmful interference in which case the user will be required to correct the interference at his own expense.

You are cautioned that any changes or modifications not expressly approved in this manual could void your authority to operate this equipment.

All interface cables used to connect peripherals must be shielded in order to comply with the limits for a digital device pursuant to Subpart B of part 15 of FCC Rules.

This device complies with part 15 of the FCC Rules. Operation is subject to the following two conditions: (1) This device may not cause harmful interference, and (2) this device must accept any interference received, including interference that may cause undesired operation.

#### **For the customers in Canada**

CAN ICES-3 (A)/NMB-3(A)

#### **For the customers in Europe**

This product is intended for use in the following Electromagnetic Environment: E4 (controlled EMC environment, ex. TV studio).

This apparatus shall not be used in the residential area.

## For the customers in Europe, Australia and New Zealand

### WARNING

This equipment is compliant with Class A of CISPR 32. In a residential environment this equipment may cause radio interference.

### Disposal of Old Electrical & Electronic Equipment (Applicable in Republic of India)



This symbol indicates that this product and its components, consumables, parts or spares thereof shall not be treated as household waste and may not be dropped in garbage bins. Product owners are advised to deposit their product at the nearest collection point for the recycling of electrical and electronic equipment. Your co-operation shall facilitate proper disposal & help prevent potential negative consequences/hazards to the environment and human health, which could otherwise be caused by inappropriate waste disposal including improper handling, accidental breakage, damage and/ or improper recycling of e-waste. The recycling of materials will help to conserve natural resources. For more detailed information about recycling of this product, please contact your local civic office, your household waste disposal service provider or the store where you made the purchase. You may contact our company's toll free number in India for assistance.

Toll Free: 1800-103-7799

Visit: [www.sony.co.in](http://www.sony.co.in) for product recycling

### Reduction in the Use of Hazardous Substances in Electrical & Electronic Equipment (Applicable in Republic of India)

This product and its components, consumables, parts or spares comply with the hazardous substances restriction of India's E-Waste (Management) Rules. The maximum allowable concentrations of the restricted substances are 0.1% by weight in homogenous materials for Lead, Mercury, Hexavalent Chromium, Polybrominated Biphenyls (PBB) and Polybrominated Diphenyl Ethers (PBDE), and 0.01% by weight in homogenous materials for Cadmium, except for the exemptions specified in Schedule II of the aforesaid Rules.

### For the customers in the U.S.A.

**SONY LIMITED WARRANTY** - Please visit <http://www.sony.com/psa/warranty> for important information and complete terms and conditions of Sony's limited warranty applicable to this product.

### For the customers in Canada

**SONY LIMITED WARRANTY** - Please visit <http://www.sonybiz.ca/pro/lang/en/ca/article/resources-warranty-product-registration> for important information and complete terms and conditions of Sony's limited warranty applicable to this product.

### For the customers in Europe

Sony Professional Solutions Europe - Standard Warranty and Exceptions on Standard Warranty. Please visit <http://www.pro.sony.eu/warranty> for important information and complete terms and conditions.

### For the customers in Korea

**SONY LIMITED WARRANTY** - Please visit <http://bpeng.sony.co.kr/handler/BPAS-Start> for important information and complete terms and conditions of Sony's limited warranty applicable to this product.

### For kundene i Norge

Dette utstyret kan kobles til et IT-strømfordelingssystem.

Apparatet må tilkoples jordet stikkontakt

### Suomessa asuville asiakkaille

Laite on liitettävä suojamaadoituskoskettimilla varustettuun pistorasiaan

### För kunderna i Sverige

Apparaten skall anslutas till jordat uttag

### For kunder i Danmark

Apparatets stikprop skal tilsluttes en stikkontakt med jord, som giver forbindelse til stikproppens jord.

### Türkiye'deki müşteriler için

**AEEE Yönetmeliğine Uygundur**

# Table of Contents

<b>Precaution</b> .....	<b>6</b>
On Safety .....	6
On Installation .....	6
Connecting to Other Devices .....	6
Handling the Screen .....	6
On Burn-in .....	6
On a Long Period of Use .....	7
On the Surface of the Unit .....	7
On Long Periods of Continuous Use .....	7
Handling and Maintenance of the Screen .....	7
On Dew Condensation .....	7
On Repacking .....	7
Disposal of the Unit .....	7
On Fan Error .....	8
<b>Location and Function of Parts and Controls</b> .....	<b>9</b>
Front Panel.....	9
Input Signals and Adjustable/Setting Items .....	11
Rear Panel.....	13
<b>Preventing Falling of the Monitor (BVM-E251)</b> .....	<b>15</b>
<b>Mounting the Unit in a Rack (BVM-E171)</b> .....	<b>15</b>
<b>Attaching the Handle (BVM-E171)</b> .....	<b>16</b>
<b>Connecting the Controller (BKM-17R)</b> .....	<b>16</b>
<b>Connecting Multiple Units with the LAN</b> ...	<b>17</b>
<b>Connecting the HDMI cable</b> .....	<b>18</b>
<b>Connecting the Power Cord</b> .....	<b>19</b>
To connect the AC power cord .....	19
Turning on the Monitor .....	19
<b>Initial settings</b> .....	<b>20</b>
<b>Setting for the LAN to Connect Multiple Units</b> .....	<b>22</b>
<b>Selecting the Monitor (Designation of the Monitor or Group ID Number)</b> .....	<b>23</b>
<b>Using the Menu</b> .....	<b>24</b>
Menu Operation Buttons.....	24
Setting and Adjusting Using the Menu .....	24
Entering the Channel Number .....	27
Aborting Menu Operation .....	27
<b>Protection of the Setting Values</b> .....	<b>28</b>
Protecting the setting values using the [Key Protect] .....	28
Protecting the setting values using [Password] .....	28
<b>Adjustment Using the Menus</b> .....	<b>28</b>
Items .....	28
[Adjustment] Menu .....	31
[Channel Configuration] Menu .....	35
[Auxiliary Setting] Menu .....	42

[Function Setting] Menu .....	43
[System Configuration] Menu .....	57
[File Management] Menu .....	62
[System Status] Menu .....	64
[Controller] Menu .....	66
[Key Protect] Menu .....	69
<b>Displaying the Monitor Status Page</b> .....	<b>70</b>
<b>Upgrading the Monitor and Controller</b> .....	<b>72</b>
Saving the Upgrade Data in a USB memory stick, etc. ....	72
Upgrading the Monitor .....	73
Upgrading the Controller .....	74
<b>Connecting the SDI Signals</b> .....	<b>75</b>
<b>Troubleshooting</b> .....	<b>76</b>
<b>Specifications</b> .....	<b>77</b>
BVM-E251 .....	77
BVM-E171 .....	78
Available Signal Formats.....	80
Aperture Modification Frequency.....	85
Picture Display Size .....	86
Picture Frame Display .....	89
Scan Mode Image .....	91
Inserting/Ejecting the USB memory stick .....	92
<b>Dimensions</b> .....	<b>94</b>
BVM-E251 .....	94
BVM-E171 .....	96

The terms HDMI and HDMI High-Definition Multimedia Interface, and the HDMI Logo are trademarks or registered trademarks of HDMI Licensing LLC in the United States and other countries.

---

# Precaution

---

## On Safety

- Operate the unit only with a power source as specified in the “Specifications” section.
- A nameplate indicating operating voltage, etc., is located on the rear panel.
- Should any solid object or liquid fall into the cabinet, unplug the unit and have it checked by qualified personnel before operating it any further.
- Do not drop or place heavy objects on the power cord. If the power cord is damaged, turn off the power immediately. It is dangerous to use the unit with a damaged power cord.
- Unplug the unit from the wall outlet if it is not to be used for several days or more.
- Disconnect the power cord from the AC outlet by grasping the plug, not by pulling the cord.
- The socket-outlet shall be installed near the equipment and shall be easily accessible.

---

## On Installation

- Allow adequate air circulation to prevent internal heat build-up.  
Do not place the unit on surfaces (rugs, blankets, etc.) or near materials (curtains, draperies) that may block the ventilation holes.
- Do not install the unit in a location near heat sources such as radiators or air ducts, or in a place subject to direct sunlight, excessive dust, mechanical vibration or shock.

### BVM-E251

When installing the installation space must be secured in consideration of the ventilation and service operation.

- Do not block the ventilation slots, and vents of the fans.
- Leave a space around the unit for ventilation.
- Leave more than 40 cm of space in the rear of the unit to secure the operation area.

When the unit is installed on the desk or the like, leave at least 1U (4.4 cm) of space above and below the unit. Leaving more than 40 cm of space above the unit is recommended in consideration of service operation.

### BVM-E171

When the unit is installed in a rack, leave at least 1U (4.4 cm) of space above and below, 1.0 cm of space left and right between the rack and the unit.

---

## Connecting to Other Devices

When connecting this unit to other devices, turn off this unit and the other devices beforehand. Connecting while turned on may cause a malfunction to this unit and the other devices.

---

## Handling the Screen

- The OLED panel fitted to this unit is manufactured with high precision technology, giving a functioning pixel ratio of at least 99.99%. Thus a very small proportion of pixels may be “stuck”, either always off (black), always on (red, green, or blue), or flashing. In addition, over a long period of use, because of the physical characteristics of the organic light-emitting diode, such “stuck” pixels may appear spontaneously. These problems are not a malfunction.
- Do not leave the screen facing the sun as it can damage the screen. Take care when you place the unit by a window.
- Do not push or scratch the monitor’s screen. Do not place a heavy object on the monitor’s screen. This may cause the screen to lose uniformity.
- The screen and the cabinet become warm during operation. This is not a malfunction.

---

## On Burn-in

Due to the characteristics of the material used in the OLED panel, permanent burn-in or reduction in brightness may occur.

These problems are not a malfunction.

### Images that may cause burn-in

- Masked images with aspect ratios other than 16:9
- Color bars or images that remain static for a long time
- Character or message displays that indicate settings or the operating state
- On-screen displays such as center markers or area markers
- Images with a frame (including Multi-View displays)

### To reduce the risk of burn-in

- Turn off the character and marker displays  
Press the MENU button to turn off the character displays. To turn off the character or marker displays of the connected equipment, operate the connected equipment accordingly. For details, refer to the operation manual of the connected equipment.
- Do not display the images with a frame for a long time. Also, consider removing the frame during the Multi-View display, or displaying the signal level of the frame area by about 50% of the display area.
- Reduce the brightness

Reduce the brightness as much as possible or reduce the input signal level when you do not use the display.

- Turn off the power when not in use  
Turn off the power if the monitor is not to be used for a prolonged period of time.

### **Screen saver**

This product has a built-in screen saver function to reduce burn-in. When an almost still image is displayed for more than 10 minutes, the screen saver starts automatically and the brightness of the screen decreases.

---

## **On a Long Period of Use**

Due to an OLED's panel structure and characteristics of materials in its design, displaying static images for extended periods, or using the unit repeatedly in a high temperature/high humidity environments may cause image smearing, burn-in, areas of which brightness is permanently changed, lines, or a decrease in overall brightness.

In particular, continually displaying an image smaller than the monitor screen, such as displaying an image in a different aspect ratio or displaying an image with a frame, may expedite the above issues.

Avoid displaying a still image for an extended period, or using the unit repeatedly in a high temperature/high humidity environment such as an airtight room, or around the outlet of an air conditioner.

To prevent any of the above issues, we recommend reducing brightness slightly, and to turn off the power whenever the unit is not in use.

---

## **On the Surface of the Unit**

The surface of the unit becomes extremely hot. Do not touch the surface with your hand or body during power distribution. It may cause a burn.

---

## **On Long Periods of Continuous Use**

Using this unit for extended periods may cause eyestrain or reduction of eyesight.

As soon as you feel physical discomfort or pain, stop using this unit immediately and take a break.

If the physical discomfort or pain remains even after taking a break, consult a physician.

---

## **Handling and Maintenance of the Screen**

The surface of the screen is specially coated to reduce image reflection. Make sure to observe the following points as improper maintenance procedures may impair the screen's performance. In addition, the screen is vulnerable to damage. Do not scratch or knock against it using a hard object.

- Be sure to disconnect the AC power cord from the AC outlet before performing maintenance.
- The surface of the screen is specially coated. Do not attach adhesive objects, such as stickers, on it.
- The surface of the screen is specially coated. Do not touch the screen directly.
- Wipe the screen surface gently with the supplied cleaning cloth or a soft dry cloth to remove dirt.
- Stubborn stains may be removed with the supplied cleaning cloth, or a soft cloth slightly dampened with a mild detergent solution.
- The screen may become scratched if the cleaning cloth is dusty.
- Never use strong solvents such as alcohol, benzene, thinner, acidic or alkaline detergent, detergent with abrasives, or chemical wipe as these may damage the screen.
- Use a blower to remove dust from the screen surface.

---

## **On Dew Condensation**

If the unit is suddenly taken from a cold to a warm location, or if ambient temperature suddenly rises, moisture may form on the outer surface of the unit and/or inside of the unit. This is known as condensation. If condensation occurs, turn off the unit and wait until the condensation clears before operating the unit. Operating the unit while condensation is present may damage the unit.

---

## **On Repacking**

Do not throw away the carton and packing materials. They make an ideal container which to transport the unit.

---

## **Disposal of the Unit**

- Do not dispose of the unit with general waste.  
Do not include the monitor with household waste.
- When you dispose of the monitor, you must obey the law in the relative area or country.

---

## On Fan Error

The fan for cooling the unit is built in. When the fan stops and the OPERATE indicator flashes in red, the OVER RANGE indicator flashes in amber, and the STATUS indicator lights in magenta on the front panel for fan error indication, turn off the power and contact an authorized Sony dealer.

### About this manual

The instructions in this manual are for the following two models:

- BVM-E251
- BVM-E171

The illustration of BVM-E251 is used for the explanations. Any differences in specifications are clearly indicated in the text.

The controller for operating this unit used for the explanation is the BKM-17R. When you use the BKM-16R, refer to the operating instructions of BKM-16R.



# Location and Function of Parts and Controls

## Front Panel

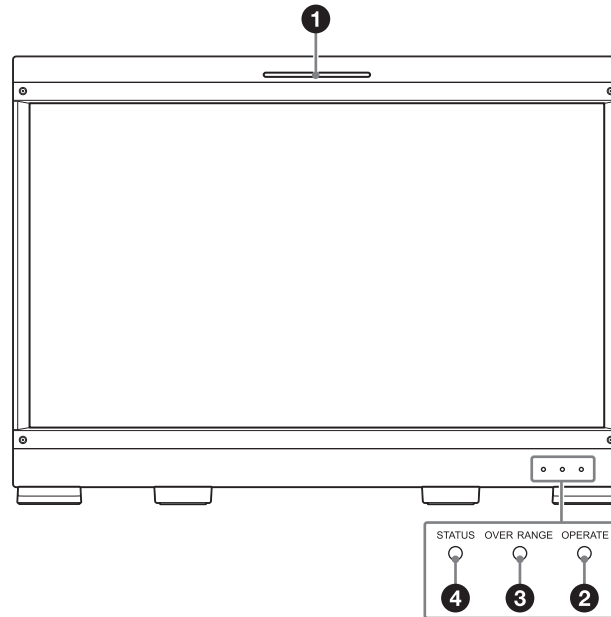

### 1 Tally lamp

With factory settings, the tally lamp lights when pins No. 5 and No. 8 of the PARALLEL REMOTE connector on the rear panel are shorted. By changing the setting in the [Parallel Remote] menu (page 58) of the [System Configuration] menu, different pins on the PARALLEL REMOTE connector can be used to control the tally lamp.

### 2 OPERATE indicator

When the power switch (on the rear panel) is turned on, internal data initialization starts and the OPERATE indicator flashes in red for a while. When the signal is output, the indicator flashes in green to indicate that data initialization continues. When initialization is finished and the monitor enters its operation mode, the indicator lights in green.

The OPERATE indicator is lit in red when the monitor is in sleep mode.

**The monitor will be in sleep mode under the following conditions:**

- [Sleep Mode] is set to [On] in the [Power] menu (page 58) of the [System Configuration] menu and the power switch (on the rear panel) is turned on. (The OPERATE indicator will flash for initialization after the switch is turned on, then will light.)
- The monitor is changed from operation mode to sleep mode by external control.

Lights in green when the monitor is put into operation mode from sleep mode by pressing the MONITOR | / ⏻ switch of the controller.

### Notes

- When the OPERATE indicator is flashing in red, the monitor cannot be put into operation mode. Wait until the indicator is steadily lit.
- When the OPERATE indicator is flashing in green, the monitor is not in full operation mode and images cannot be displayed correctly. Wait until the indicator is steadily lit in green.

*The OPERATE indicator may indicate an error or warning. For details, see “About error/warning signals of the indicator” (page 10).*

### 3 OVER RANGE indicator

Lights in amber when ABL (Automatic Brightness Limiter) starts. Also lights in amber when the signal level has exceeded the dynamic range of the signal processing circuit.

Decrease the contrast or brightness when the OVER RANGE indicator is lit.

*The OVER RANGE indicator may indicate an error or warning. For details, see “About error/warning signals of the indicator” (page 10).*

### 4 STATUS indicator

The indicator starts flashing rapidly approximately one minute before the screen saver is activated.

Flashing slows in yellow when the screen saver starts.

*The STATUS indicator may indicate an error or warning. For details, see “About error/warning signals of the indicator” (page 10).*

## About error/warning signals of the indicator

The OVER RANGE indicator, OPERATE indicator, and/or STATUS indicator on the front panel may show an error or warning while the monitor is being operated.

If the error or warning is shown, please contact your Sony representative.

### Error display

<b>STATUS indicator</b>	<b>OVER RANGE indicator</b>	<b>OPERATE indicator</b>	<b>Symptom</b>
Lights in yellow	Lights in amber	Flashes in red	The power in the panel part is unusual.
Lights in yellow	Flashes in amber	Flashes in red	The temperature in the panel part is unusual.
Flashes in yellow	Lights in amber	Flashes in red	The ambient temperature sensor is unusual.
Flashes in yellow	Flashes in amber	Flashes in red	Error at restarting.
Lights in magenta	Flashes in amber	Flashes in red	Fan error.
Flashes in magenta	Lights in amber	Flashes in red	Device error.

### Warning display

<b>STATUS indicator</b>	<b>OVER RANGE indicator</b>	<b>OPERATE indicator</b>	<b>Symptom</b>
–	Flashes in amber	–	The luminance is reduced to protect the panel from an increase of temperature in the panel part.
–	Lights in amber	–	Over range

–: Status except for error display.

## Input Signals and Adjustable/Setting Items

Item	Input signal					HDMI
	Analog	SDI			Composite	
	Composite	SD	3G/HD			
		YCbCr	YCbCr	RGB		
CONTRAST	<input type="radio"/>	<input type="radio"/>	<input type="radio"/>	<input type="radio"/>	<input type="radio"/>	<input type="radio"/>
BRIGHT	<input type="radio"/>	<input type="radio"/>	<input type="radio"/>	<input type="radio"/>	<input type="radio"/>	<input type="radio"/>
CHROMA	<input type="radio"/>	<input type="radio"/>	<input type="radio"/>	<input type="checkbox"/>	<input type="checkbox"/>	<input type="radio" value="7"/>
PHASE	<input type="radio"/> (NTSC)	<input type="checkbox"/>	<input type="checkbox"/>	<input type="checkbox"/>	<input type="checkbox"/>	<input type="checkbox"/>
Picture Auto Adjust	<input type="radio"/>	<input type="checkbox"/>	<input type="checkbox"/>	<input type="checkbox"/>	<input type="checkbox"/>	<input type="checkbox"/>
NTSC Setup Level	<input type="radio"/> (NTSC)	<input type="checkbox"/>	<input type="checkbox"/>	<input type="checkbox"/>	<input type="checkbox"/>	<input type="checkbox"/>
Position Adj	<input type="radio" value="14"/>	<input type="checkbox"/>	<input type="checkbox"/>	<input type="checkbox"/>	<input type="checkbox"/>	<input type="checkbox"/>
Gamut Error Display	<input type="checkbox"/>	<input type="radio"/>	<input type="radio"/>	<input type="radio" value="1"/>	<input type="checkbox"/>	<input type="radio" value="1"/>
Scan Mode	<input type="radio" value="14"/>	<input type="radio"/>	<input type="radio"/>	<input type="radio"/>	<input type="radio"/>	<input type="radio" value="8"/>
Native Scan (×1, ×2) <sup>2)</sup>	<input type="radio"/>	<input type="radio"/>	<input type="radio"/>	<input type="radio"/>	<input type="radio"/>	<input type="radio"/>
Native Scan (Aspect Correction)	<input type="radio"/>	<input type="radio"/>	<input type="checkbox"/>	<input type="checkbox"/>	<input type="checkbox"/>	<input type="radio" value="6"/> <sup>9)</sup>
16:9	<input type="radio"/>	<input type="radio"/>	<input type="radio" value="3"/>	<input type="radio" value="4"/>	<input type="radio" value="4"/>	<input type="radio" value="5"/> <sup>9)</sup> <sup>10)</sup>
H Delay	<input type="checkbox"/>	<input type="radio"/>	<input type="radio"/>	<input type="radio"/>	<input type="radio"/>	<input type="checkbox"/>
V Delay	<input type="checkbox"/>	<input type="radio"/>	<input type="radio"/>	<input type="radio"/>	<input type="radio"/>	<input type="checkbox"/>
Char Off	<input type="radio"/>	<input type="radio"/>	<input type="radio"/>	<input type="radio"/>	<input type="radio"/>	<input type="radio"/>
Color Temp	<input type="radio"/>	<input type="radio"/>	<input type="radio"/>	<input type="radio"/>	<input type="radio"/>	<input type="radio"/>
Status	<input type="radio"/>	<input type="radio"/>	<input type="radio"/>	<input type="radio"/>	<input type="radio"/>	<input type="radio"/>
Aperture <sup>11)</sup>	<input type="radio"/>	<input type="radio"/>	<input type="radio"/>	<input type="radio"/>	<input type="radio"/>	<input type="radio"/>
Mono	<input type="radio"/>	<input type="radio"/>	<input type="radio"/>	<input type="radio"/>	<input type="radio"/>	<input type="radio"/>
Blue Only	<input type="radio"/>	<input type="radio"/>	<input type="radio"/>	<input type="radio"/>	<input type="radio"/>	<input type="radio"/>
R Off	<input type="radio"/>	<input type="radio"/>	<input type="radio"/>	<input type="radio"/>	<input type="radio"/>	<input type="radio"/>
G Off	<input type="radio"/>	<input type="radio"/>	<input type="radio"/>	<input type="radio"/>	<input type="radio"/>	<input type="radio"/>
B Off	<input type="radio"/>	<input type="radio"/>	<input type="radio"/>	<input type="radio"/>	<input type="radio"/>	<input type="radio"/>
Chroma Up	<input type="radio"/>	<input type="radio"/>	<input type="radio"/>	<input type="checkbox"/>	<input type="checkbox"/>	<input type="radio" value="7"/>
Interlace	See "Picture Frame Display" on page 89.					
Pixel Zoom	<input type="radio"/>	<input type="radio"/>	<input type="radio"/>	<input type="radio"/>	<input type="radio"/>	<input type="radio"/>
Capture	<input type="checkbox"/>	<input type="checkbox"/>	<input type="radio"/>	<input type="radio"/>	<input type="radio"/>	<input type="checkbox"/>
Capture Load	<input type="radio"/>	<input type="radio"/>	<input type="radio"/>	<input type="radio"/>	<input type="radio"/>	<input type="radio"/>
Marker	<input type="radio"/>	<input type="radio"/>	<input type="radio"/>	<input type="radio"/>	<input type="radio"/>	<input type="radio" value="9"/>
Aspect Marker	<input type="radio"/>	<input type="radio"/>	<input type="radio"/>	<input type="radio"/>	<input type="radio"/>	<input type="radio" value="9"/>
Area Marker 1	<input type="radio"/>	<input type="radio"/>	<input type="radio"/>	<input type="radio"/>	<input type="radio"/>	<input type="radio" value="9"/>
Area Marker 2	<input type="radio"/>	<input type="radio"/>	<input type="radio"/>	<input type="radio"/>	<input type="radio"/>	<input type="radio" value="9"/>
Center Marker	<input type="radio"/>	<input type="radio"/>	<input type="radio"/>	<input type="radio"/>	<input type="radio"/>	<input type="radio" value="9"/>
Aspect Marker-Line	<input type="radio"/>	<input type="radio"/>	<input type="radio"/>	<input type="radio"/>	<input type="radio"/>	<input type="radio" value="9"/>
Aspect Blanking-Half	<input type="radio"/>	<input type="radio"/>	<input type="radio"/>	<input type="radio"/>	<input type="radio"/>	<input type="radio" value="9"/>
Aspect Blanking-Black	<input type="radio"/>	<input type="radio"/>	<input type="radio"/>	<input type="radio"/>	<input type="radio"/>	<input type="radio" value="9"/>
Side by Side	<input type="radio"/>	<input type="radio"/>	<input type="radio"/>	<input type="radio"/>	<input type="radio"/>	<input type="radio"/>
Wipe	<input type="radio"/>	<input type="radio"/>	<input type="radio"/>	<input type="radio"/>	<input type="radio"/>	<input type="radio"/>
Butterfly	<input type="radio"/>	<input type="radio"/>	<input type="radio"/>	<input type="radio"/>	<input type="radio"/>	<input type="radio"/>

Item	Input signal					HDMI
	Analog	SDI			HDMI	
	Composite	SD	3G/HD			
		YCbCr	YCbCr	RGB		
Blending	○	○	○	○	○	○
Error Notify Clear	×	○	○	○ <sup>1)</sup>	×	○ <sup>1)</sup>
Audio Level Meter <sup>12)</sup>	×	○	○	○	×	×
ALM Hold Reset <sup>12)</sup>	×	○	○	○	×	×
Time Code	×	○	○	○	×	×
Flicker Free	○	○	○	○	○	○
Closed Caption	×	○ <sup>13)</sup>	○ <sup>15)</sup>	×	×	×

○ : Adjustable/can be set  
 × : Not adjustable/cannot be set

- 1) Does not function when the RGB signal with the quantization range set to Full is selected. It functions, however, if [Gamma] is set to [S-LOG2(SDR)] or [S-LOG3(SDR)] in the [Color Profile] menu.
- 2) Fixed to [×1] when the HD signal or the computer signal of HDMI is input and [×2] when the SD signal is input.
- 3) Fixed to [16:9] with 720P input signal.
- 4) Becomes [1.896:1] with 2048 × 1080 input signal.
- 5) Excludes 640 × 480/60\*P. Fixed to [16:9] with 1280 × 720/50P, 60\*P. (\* Also compatible with 1/1.001.)
- 6) In effect with SD format
- 7) Functions when the YCbCr signal is input.
- 8) Fixed to [Native Scan] ([×1]) when the computer signal of HDMI is input.
- 9) Does not function when the computer signal of HDMI is input.
- 10) Functions when the [HDMI Auto] menu (page 38) of the [Screen Aspect] menu is set to [Off].
- 11) For the operable input signal, see “Aperture Modification Frequency” (page 85).
- 12) Sets when the SDI signal is input
- 13) Enabled only when the signal system is 480/59.94i.
- 14) When the composite signal is input and [Under Scan] is selected, the blanking area of the horizontal direction is masked.
- 15) Enabled during HD-SDI only

# Rear Panel

## BVM-E251

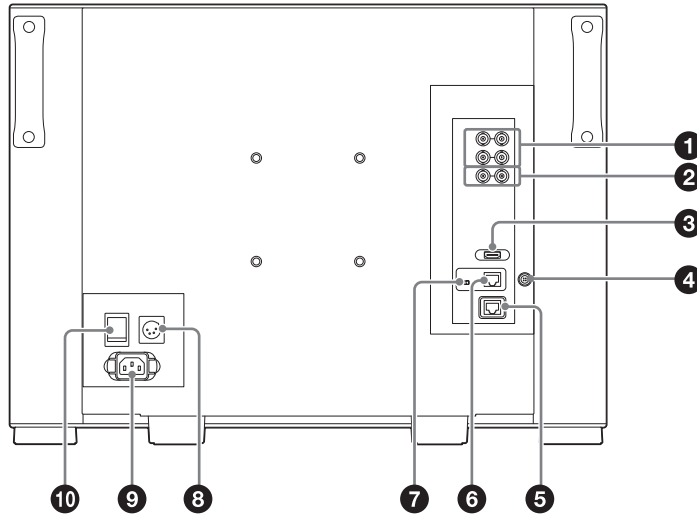

## BVM-E171

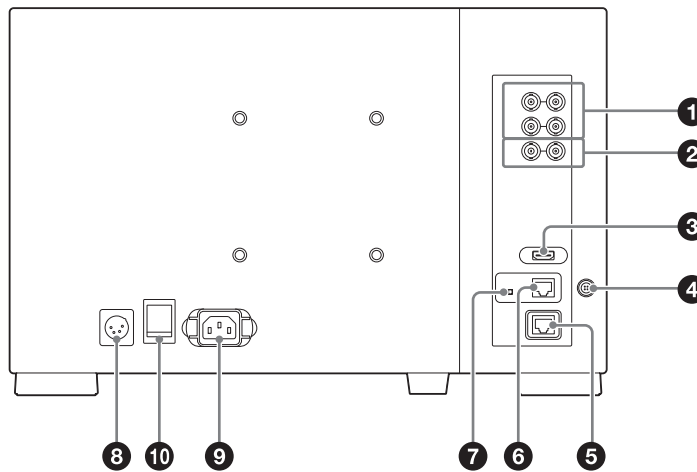

- 1 SDI input and output connectors (BNC)**  
**SDI 1 IN connector**  
 Input connector for serial digital signals.  
**SDI 2 IN connector**  
 Input connector for serial digital signals.  
**MONITOR OUT connector**  
 MONITOR OUT for SDI 1 IN and SDI 2 IN connectors.
- 2 COMPOSITE input and output connectors (BNC)**  
**IN connector**  
 Input connector for composite video signals.  
**OUT connector**  
 Loop-through output connector.

### Notes

- When the composite signal is used, adjust the signal level in the [Picture Adj] menu (page 31).
- When inputting a video signal with the jitters, etc. the picture may be disturbed. We recommend using the TBC (time base corrector).
- When the unit is turned off, the signal wave of the COMPOSITE input and output connectors may be distorted.

- 3 HDMI IN (HDMI input) connector**  
 Input connector for HDMI <sup>1)</sup> signals.  
 HDMI (High-Definition Multimedia Interface) is an interface that supports both video and audio on a single digital connection, allowing you to enjoy high quality digital picture and sound. The HDMI specification supports HDCP (High-bandwidth Digital Content

Protection), a copy protection technology that incorporates coding technology for digital video signals.

- 1) The terms HDMI and HDMI High-Definition Multimedia Interface, and the HDMI Logo are trademarks or registered trademarks of HDMI Licensing LLC in the United States and other countries.

**Note**

The HDMI audio signal is not available for this monitor. Use HDMI compliant cable (sold separately), Category 2 (High Speed HDMI Cable), with HDMI logo.

**4 DC 12V OUT connector (female)**

Supplies the DC power to the controller. Connect to the DC 12V connector of the controller with the SMF-17R20 or the cable supplied with the BKM-37H/38H/39H.

**5 PARALLEL REMOTE connector (RJ-45, 8-pin)**

Forms a parallel switch and controls the monitor externally.

**CAUTION**

For safety, do not connect the connector for peripheral device wiring that might have excessive voltage to this port. Follow the instructions for this port.

**Pin assignment**

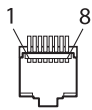

Pin number	Functions
1	Designating input signal channel 1 (numeric keypad function)
2	Designating input signal channel 2 (numeric keypad function)
3	Marker (set in the [Marker Setting] menu) On/Off (MARKER button function)
4	Selecting whether monochrome image is displayed or the monitor switches the display mode automatically between color image and monochrome image depending on the input signal (MONO button function).
5	GND
6	Not connected
7	Not connected
8	Tally lamp On/Off

You can assign functions using the [Parallel Remote] menu (page 58) of the [System Configuration] menu.

**Wiring required to use the Remote Control**

Connect the function you want to use with a Remote Control to the Ground (Pin 5).

**6 LAN (10/100) connector**

Connect to the LAN (10/100) connector of the controller by using the SMF-17R20 or the cable supplied with the BKM-37H/38H/39H. Or connect to the network or the LAN (10/100) connector of the controller by using a 10BASE-T/100BASE-TX LAN cable (shielded-type, sold separately).

**CAUTION**

- For safety, do not connect the connector for peripheral device wiring that might have excessive voltage to this port. Follow the instructions for this port.
- When you connect the LAN cable of the unit to peripheral device, use a shielded-type cable to prevent malfunction due to radiation noise.
- The connection speed may be affected by the network system. This unit does not guarantee the communication speed or quality of 10BASE-T/100BASE-TX.

**7 NETWORK switch**

**LAN:** When connecting to the network.

**PEER TO PEER:** When connecting to the LAN (10/100) connector of the controller in 1 to 1 connection.

**8 DC IN 24V – 28V (DC power input) connector (XLR 4-pin, male)**

Connect the 24V to 28V DC power supply.

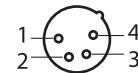

Pin number	Functions
1	– (GND)
2	NC
3	NC
4	+ (DC 24V – 28V)

**9 Power switch**

When turned on, the monitor enters operation mode. By setting in the [Power] menu (page 58) of the [System Configuration] menu, the monitor can also be set to enter sleep mode when the power switch is turned on.

**10 AC IN connector (3-pin)**

Connects the monitor to an AC power source, via the supplied AC power cord.

## Preventing Falling of the Monitor (BVM-E251)

- 1 Tie a piece of stout string (commercially available) to the left and right handles of the monitor.

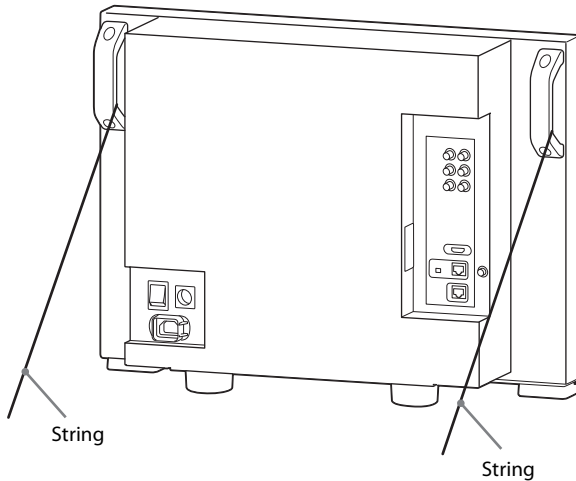

- 2 Secure the ends of the string to the floor or wall.

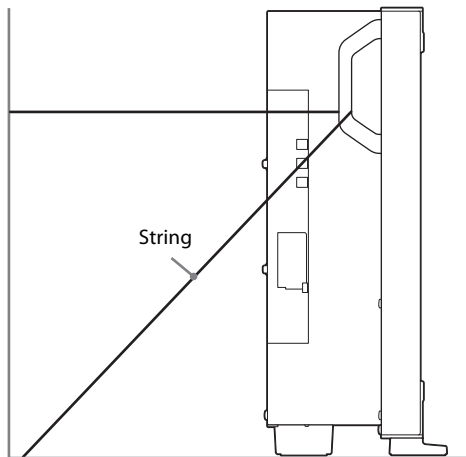

## Mounting the Unit in a Rack (BVM-E171)

To mount the unit in an EIA standard 19-inch rack, use the supplied rack mount brackets and screws.

- 1 Remove the four feet from the bottom of the unit.
- 2 Attach the rack mount brackets to each side of the unit with the supplied screws.

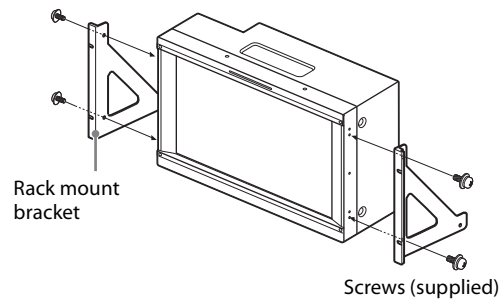

- 3 Screw the rack mount brackets to the rack to mount the unit.

Use the commercially available screws that match the size of the rack's holes.

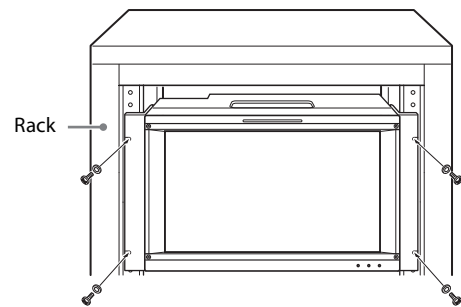

## Attaching the Handle (BVM-E171)

- 1 Remove the 2 screws on the top side.

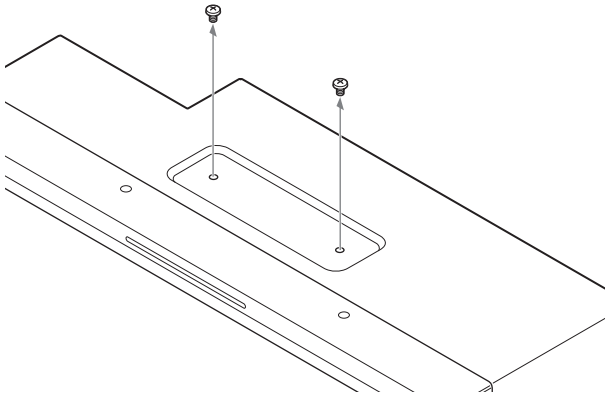

### Note

Keep the removed screws in a safe place to prevent them from being lost.

- 2 Attach the handle with the supplied screws.

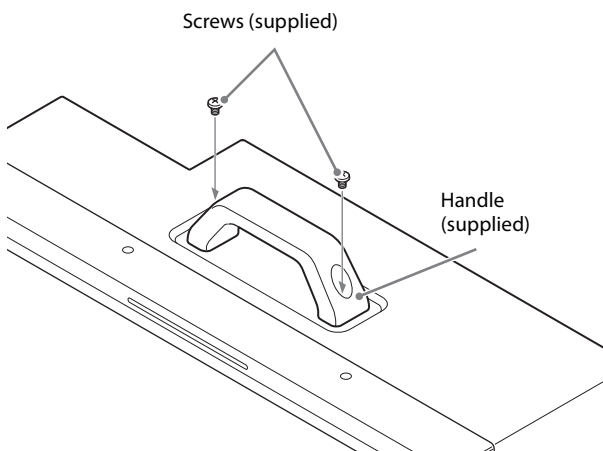

### Notes

- Make sure that the screw clamp is not loosened.
- Secure the handle attachment.

## Connecting the Controller (BKM-17R)

### Note

When you connect the BKM-16R, refer to the operating instructions of BKM-16R.

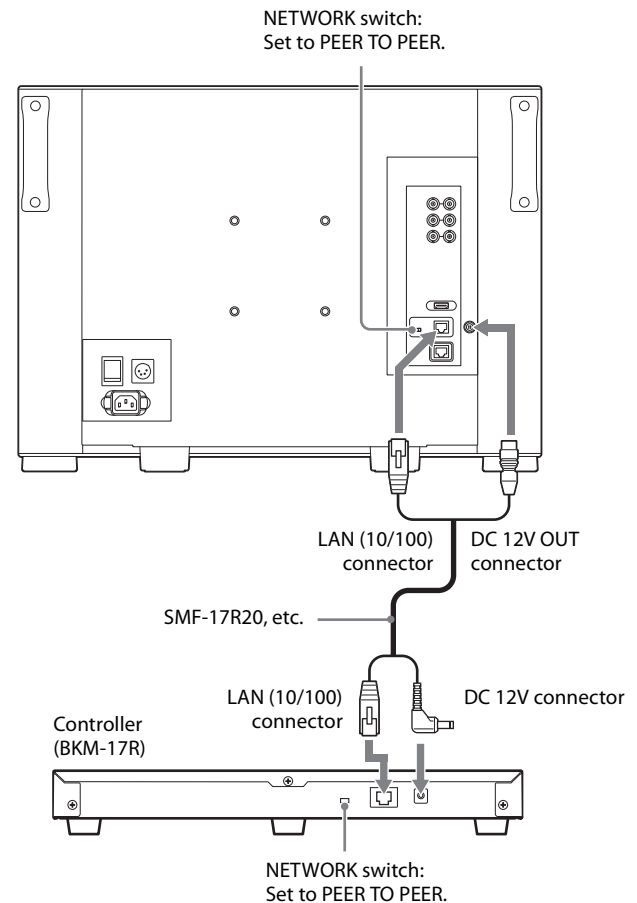

- 1 Turn off the power switch of the monitor before connecting the units.
- 2 Set the NETWORK switches of the monitor and the controller to PEER TO PEER.
- 3 Connect the LAN (10/100) connector of the monitor and the LAN (10/100) connector of the controller by using the SMF-17R20 or the cable supplied with the BKM-37H/38H/39H, or a 10BASE-T/100BASE-TX straight LAN cable (shielded-type, sold separately).
- 4 Connect the DC 12V OUT connector of the monitor and DC 12V connector of the controller by using the SMF-17R20 or the cable supplied with the



BKM-37H/38H/39H. Or connect the output cable of the AC adaptor supplied with the controller to the DC 12V connector of the controller.

### Note on connecting the cable to the DC 12V OUT connector

Insert the connector so as to fit the shape of the DC 12V OUT connector.

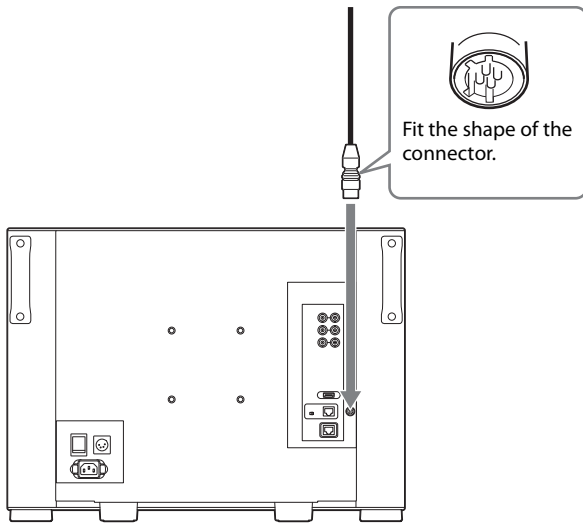

## Connecting Multiple Units with the LAN

The controller controls up to 32 monitors. Up to three controllers are connected to one monitor in single mode.

### Notes

- The controller cannot control monitors in another subnetwork.
- When you connect the BKM-16R, refer to the operating instructions of BKM-16R.

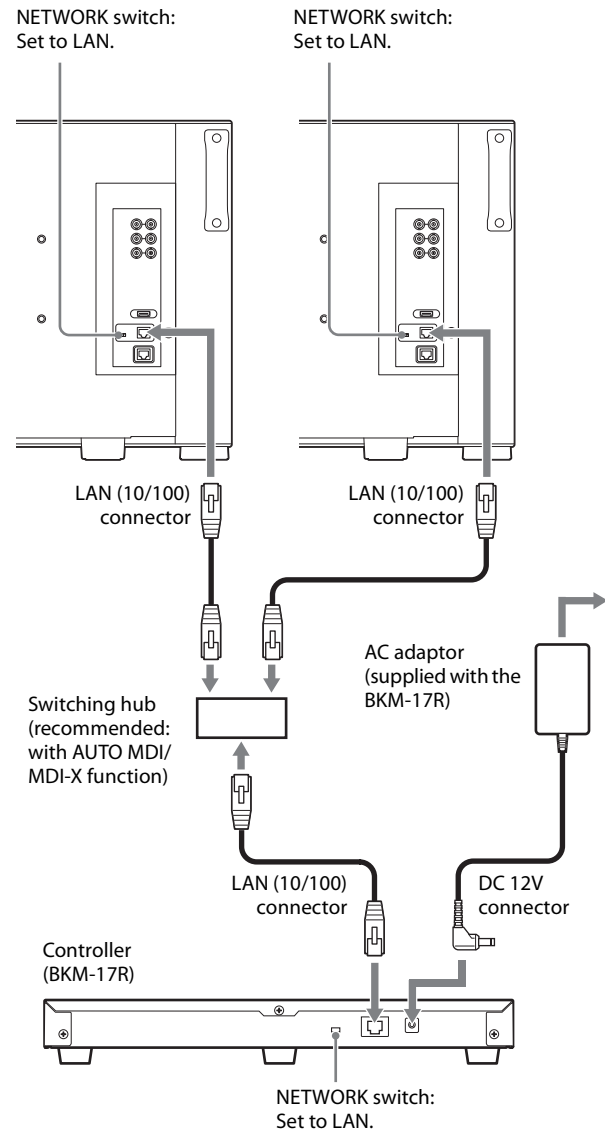

- 1 Turn off the power switch of the monitor before connecting the units.

- 2 Connect to the network by using a 10BASE-T/100BASE-TX cable (shielded-type, sold separately).

**Note**

We recommend to use an optional switching hub with auto selection function (AUTO MDI/MDI-X) of a straight/cross cable.

- 3 Connect the output cable on the AC adaptor supplied with the controller to the DC 12V connector of the controller.

**Note**

When multiple units are connected, set for the LAN before setting the NETWORK switch to LAN (page 22).

- 4 Set the NETWORK switches of each monitor and the controller to LAN.

---

## Connecting the HDMI cable

- 1 Remove the two screws on both sides of the HDMI IN connector.

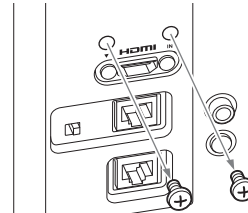

- 2 Attach the HDMI cable holder (supplied) with the removed screws.

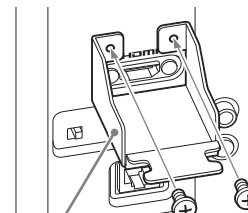

HDMI cable holder (supplied)

- 3 Insert the HDMI cable and fix with a commercially-available cable fixer (1 piece).

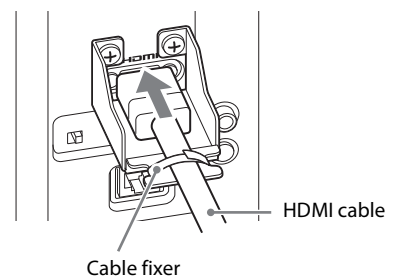

# Connecting the Power Cord

You can operate the monitor with AC or DC power supply.

## To connect the AC power cord

- 1 Plug the AC power cord into the AC IN connector on the rear panel then attach the AC plug holder (supplied) to the AC power cord.

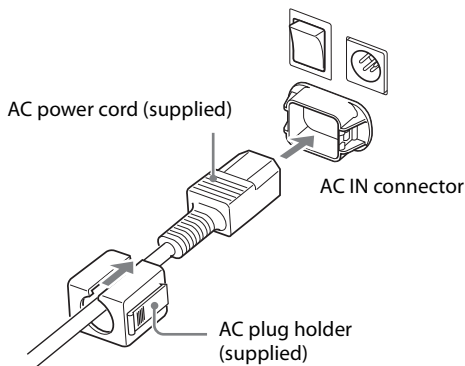

- 2 Slide the AC plug holder over the cord until it locks.

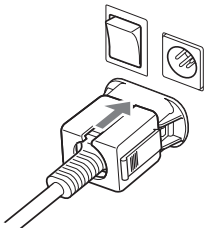

## To remove the AC power cord

Pull out the AC plug holder while pressing the lock levers.

## To connect the DC power supply

Connect the DC power supply to the DC IN 24V - 28V connector.

When the AC power cord and DC power supply are connected, the AC power supply is given preference over the DC power supply. To use the DC power supply, disconnect the AC power cord.

## Turning on the Monitor

Press the power switch on the rear panel to turn on the power.

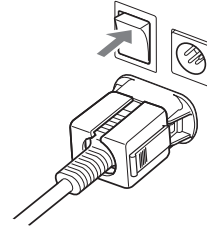

When you turn on the monitor for the first time after purchasing it, the [Select Area] screen is displayed. Select the area where you intend to use this monitor.

*For selecting the area, see page 20.*

The warm-up time is more than 30 minutes, approximately.

## When the monitor is in sleep mode

As the OPERATE indicator lights in red in sleep mode, press the MONITOR | / ⏻ switch of the controller. The OPERATE indicator lights in green and the monitor enters operation mode.

# Initial settings

When you turn on the monitor for the first time after purchasing it, select the area where you intend to use this monitor from among the options.

When the area is selected, the menu item settings suitable for the selected area are applied.

## Default value for each area

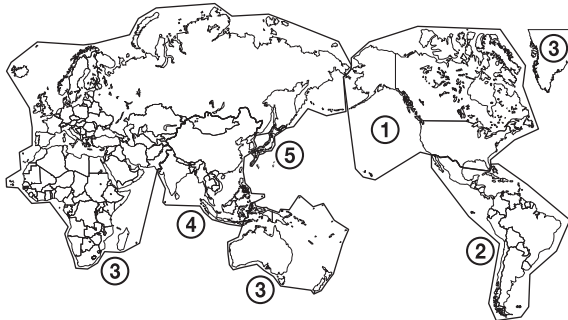

	[Color Temp]	[Setup Level]	[Color Profile]	
① [North America]	[D65]	[7.5%]	[ITU-R BT.709]	
② [Latin America] [PAL & PAL-N Area]	Argentina	[D65]	[ITU-R BT.709]	
	Paraguay	[D65]	[ITU-R BT.709]	
	Uruguay	[D65]	[ITU-R BT.709]	
	[NTSC & PAL-M Area]	Other Area	[D65]	[7.5%]
③ [Africa] [Australasia] [Europe] [Middle-East]		[D65]	[ITU-R BT.709]	
	[NTSC Area]	[D65]	[7.5%]	[ITU-R BT.709]
	[PAL Area]	[D65]	[0%]	[ITU-R BT.709]
		[D93]	[0%]	[ITU-R BT.709]
④ [Asia Except Japan]				
⑤ [Japan]				

## Note on the setting of color temperature

If you measure the color temperatures of different display types, such as CRT, LCD, or OLED, by using a common (or general) color analyzer that is based on CIE 1931, and adjust the xy chromaticity to the same value, the appearance may be different because of optical spectrum differences.

To compensate for this difference, the [D93], [D65], [D61], [D55], and [User1] to [User5] settings (except [DCI]) of the monitor are adjusted by an offset <sup>1)</sup>.

1) The offset value applied (x-0.006, y-0.011) is based on the Judd's function to the CIE 1931 (x, y) value.

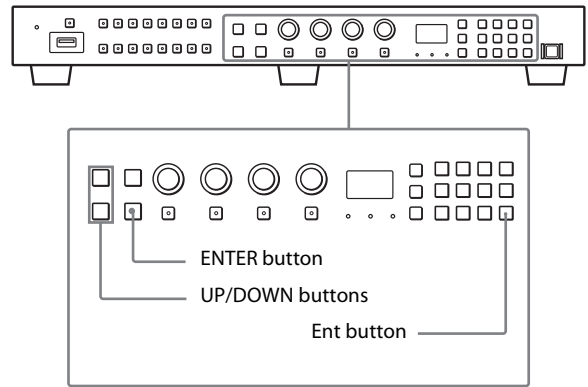

- 1 Turn on the monitor with the power switch.  
The [Select Area] screen appears.

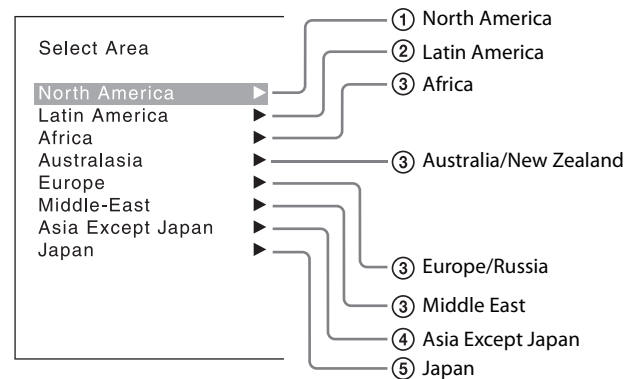

- 2 Press the UP or DOWN button of the controller to select the area where you intend to use the monitor and press the ENTER (Ent) button.

If you select either [Latin America] or [Asia Except Japan], one of the following screens appears.

**If ② [Latin America] is selected:**

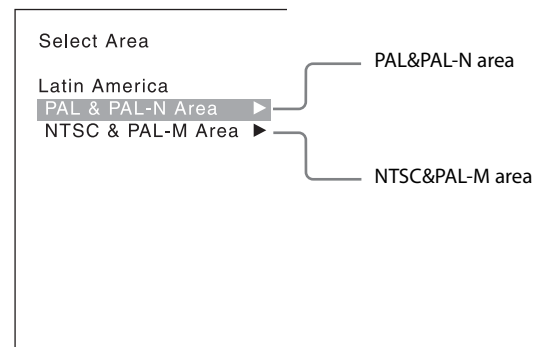

Select [PAL & PAL-N Area] or [NTSC & PAL-M Area], and press the ENTER (Ent) button.

**If ④ [Asia Except Japan] is selected:**

- [Setup Level] ([NTSC Setup Level]: page 37)
- [Color Profile] (page 39)

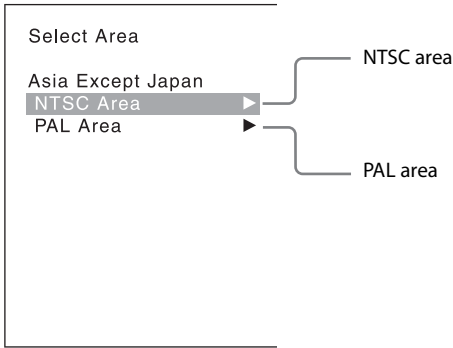

Customers who will use this monitor in the shaded areas shown in the map below should select [NTSC Area].

Other customers should select [PAL Area].  
Then press the ENTER (Ent) button.

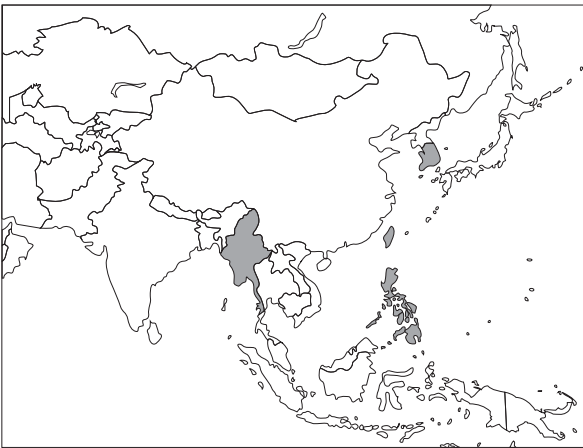

### 3 Confirm the settings.

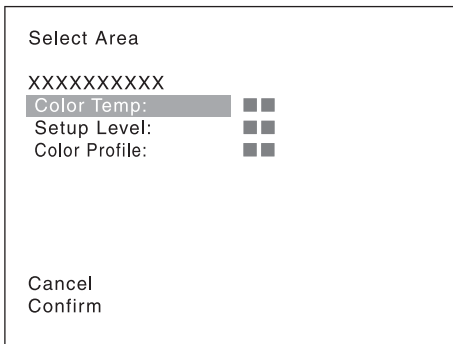

**[Cancel]:** Select to cancel the setting and return to the Select Area screen.

**[Confirm]:** Select to save the setting and end selecting the area.

See “Default value for each area” on page 20 on the setting value.

After saving and reflecting the setting, you can change the setting with the menu.

- [Color Temp] (color temperature) (page 36)

# Setting for the LAN to Connect Multiple Units

You can control the multiple monitors using the controller (BKM-17R, sold separately) connected via each LAN (10/100) connector. You can also control a specific monitor or monitor group.

Set an IP address to the monitors and controller and a monitor ID number and group ID number to each monitor.

- 1 Set the NETWORK switches of each monitor and the controller to PEER TO PEER.

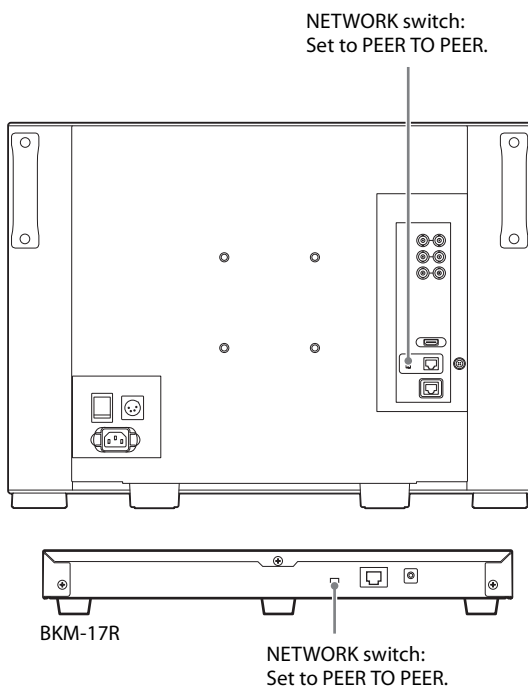

- 4 Set the NETWORK switches of the monitor and the controller to LAN.

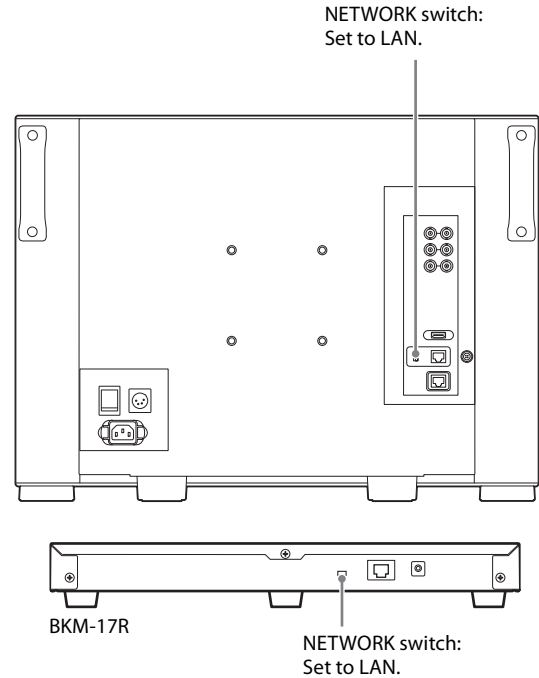

- 2 Set the different IP address to each monitor and the controller.

**Monitor:** Set the IP address in the [Network Setting] menu (page 57) of the [System Configuration] menu.

**Controller:** Set the IP address in the [Network Setting] menu (page 66) of the [Controller] menu.

- 3 Set [Monitor ID] and [Group ID] in the [Network Setting] menu (page 57) of the [System Configuration] menu.

Set the different monitor ID number to each monitor and if necessary, group ID number. You can use the numbers 1 to 99 as a monitor ID number or group ID number.

# Selecting the Monitor (Designation of the Monitor or Group ID Number)

When the multiple monitors are connected by network connections, you can remotely connect the monitors from the controller by designating the set monitor ID number or group ID number.

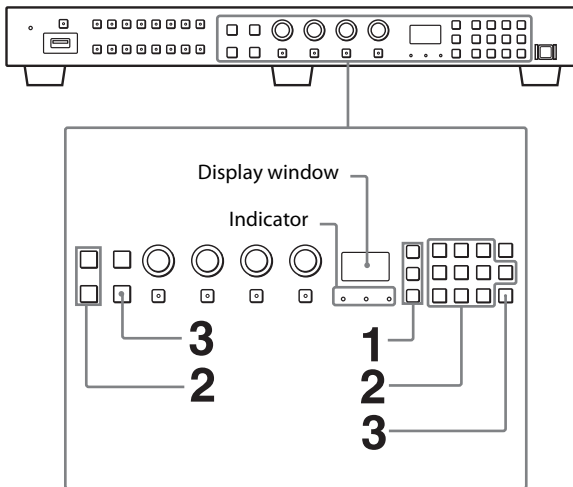

- 1 Press the corresponding button to select the connection mode.

**SINGLE button:** Selects single connection mode. The designated monitor is connected remotely. The monitor ID number is displayed on all connected monitors when the button is held down.  
**GROUP button:** Selects group connection mode. The monitor of the designated group is connected remotely. The group ID number is displayed on all connected monitors when the button is held down.  
**ALL button:** Selects all connection modes. All monitors are connected remotely.

The indicator corresponding to the pressed button flashes and lights after recognizing the monitor.

- 2 Select the monitor ID number for the single connection mode or group ID number for the group connection mode by pressing the UP/DOWN or numeric button.

Up to 99 is entered as the monitor ID or group ID number.

- 3 Press the ENTER (Ent) button to confirm the setting.

The monitor ID number, group ID number, or ALL is displayed in the display window.

## Notes

- When the monitor with no assigned monitor ID number or group ID number is selected, the setting is not changed and the previous connection status is maintained
- When there are monitors with the same ID number, the monitor with the lower IP address is selected.
- Even if a different monitor ID number is set to the monitors, when the same IP address is set to another monitor, the monitor cannot be connected to the network.

# Using the Menu

## Menu Operation Buttons

The menu is operated using the menu operation buttons on the controller (BKM-17R, sold separately)

You can also operate the unit using the BKM-16R in the same way.

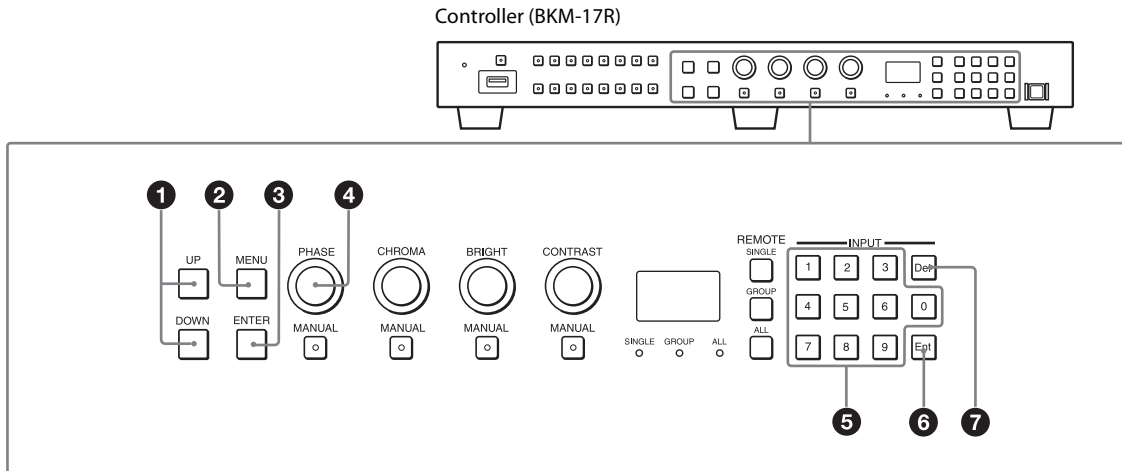

The functions of the menu operation buttons are described below.

### 1 UP /DOWN buttons

**UP button:** Moves the cursor upward. In setting mode, increases the setting or adjustment value.  
**DOWN button:** Moves the cursor downward. In setting mode, decreases the setting or adjustment value.

### 2 MENU button

Displays the menu. Goes back to the menu of the upper level. (On the main menu, goes back to the normal picture.)

### 3 ENTER button

Changes an item or displays the information on the functions assigned to function buttons. In setting mode, confirms the adjustment or setting value.

### 4 PHASE knob

By turning this knob clockwise, the cursor moves downward. In setting mode, increases the setting or adjustment value (has the same function as the UP button).  
By turning this knob counterclockwise, the cursor moves upward. In setting mode, decreases the setting or adjustment value (has the same function as the DOWN button).

### 5 Numeric buttons

Enters the numerical values

### 6 Ent button

Changes an item or displays the information on the input signal, etc. In setting mode, confirms the adjustment or setting value.

### 7 Del button

Deletes the values and characters entered.

## Setting and Adjusting Using the Menu

### 1 Press the MENU button.

The main menu is displayed on the screen.

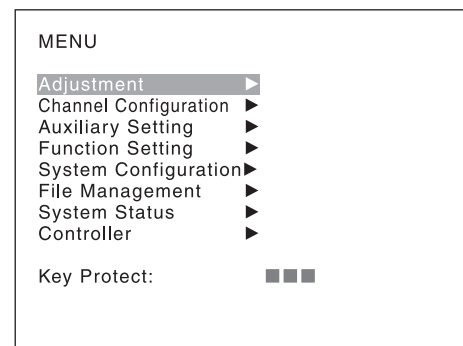

When you select one item on the main menu, the level 1 menu of the selected item appears.



**Notes**

- The menu disappears automatically if not operated for about one minute.
- Menu items displayed in gray cannot be selected.
- This menu is not displayed when [Pixel Zoom] is set to on.

**2** Using the UP or DOWN button or PHASE knob, select the desired item. (Example: select the [Channel Configuration] menu by pressing the DOWN button.)

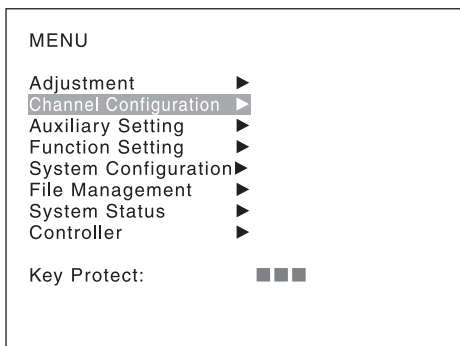

**3** Press the ENTER or Ent button

Level 1 of the selected menu is displayed. The current settings are displayed in place of the ■ marks on the illustrations of the menu screen.

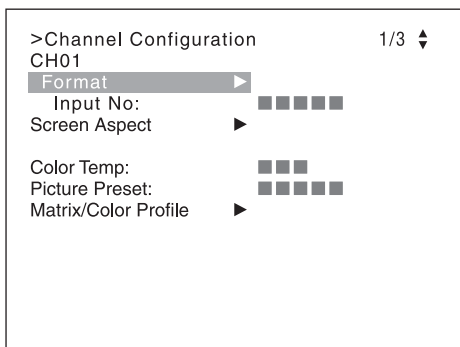

**4** Repeat steps 2 and 3 until the desired menu is displayed.

For more information about setting and adjustments, see below.

**Display example**

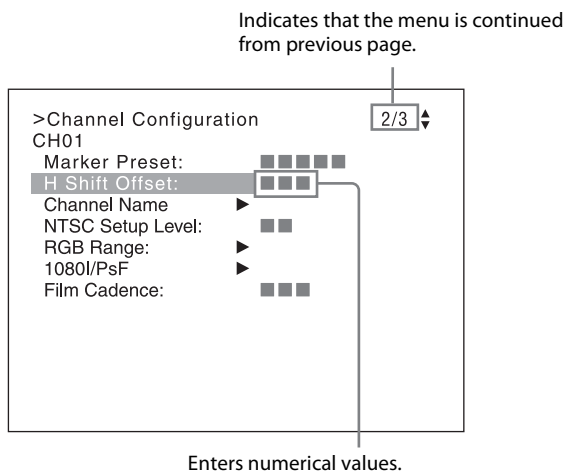
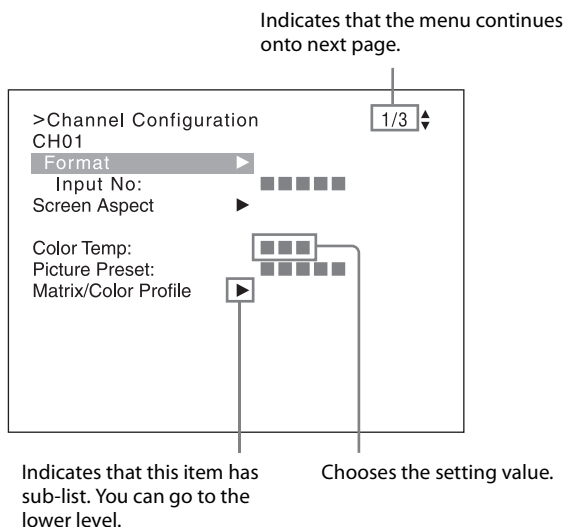

**Choosing the setting value**

The method for selecting the value is different due to the menu item.

- Selecting in setting mode
- Selecting from the setting list

**When selecting in setting mode**

**1** Using the UP or DOWN button or PHASE knob, select the desired item and press the ENTER or Ent button.

The cursor moves to the setting value and the monitor enters in setting mode.

## Display example

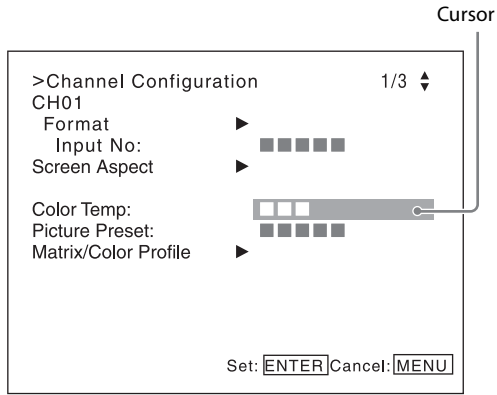

**2** Using the UP or DOWN button or PHASE knob, select the setting value.

**3** Press the ENTER or Ent button.

The setting is confirmed and the cursor returns to the item.

## When selecting from the setting list

**1** Using the UP or DOWN button or PHASE knob, select the desired item in the setting list.

### Display example

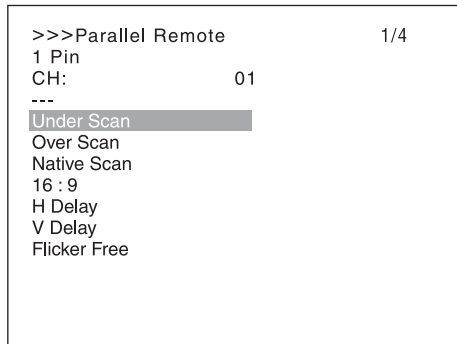

**2** Press the ENTER or Ent button.

The setting is confirmed and the display returns to the menu of the upper level.

## Entering numerical values

**1** Using the UP or DOWN button or PHASE knob, select the desired item and press the ENTER or Ent button.

The cursor moves to the setting value and the monitor enters in setting mode.

## Display example

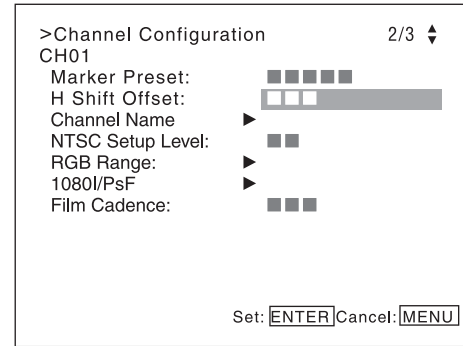

**2** Select the value in one of the following three ways:

- Enter the value directly using the numeric buttons and press the ENTER or Ent button. (only the item with a value of setting range over 0)
- Select the value using the UP or DOWN button.
- Select the value using the PHASE knob.

**3** Press the ENTER or Ent button.

The setting is confirmed and the cursor returns to the item.

## Entering characters

**1** Using the UP or DOWN button or PHASE knob, select [New Name] or the existing name.

The "---" means that one or more characters can be entered in sequence after the existing name.

**2** Press the ENTER or Ent button.

**3** Using the UP or DOWN button or PHASE knob, select the characters that you wish to enter.

### Display example

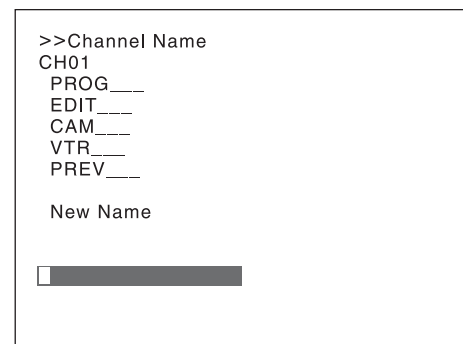

When you press the UP button or turn the PHASE knob clockwise, the characters and symbols appear in the sequence shown below.

Capital letters (A → B → ..... → Y → Z) →  
Lower-case letters (a → b → ..... → y → z) →  
Numbers (0 → 1 → ..... → 8 → 9) → Marks →  
Capital letters...

When you press the DOWN button or turn the PHASE knob counterclockwise, the characters and symbols appear in the reverse sequence described above.

The usable symbols are limited depending on the menu. "(space)" is not used as a first character of a sentence.

#### 4 Press the ENTER or Ent button.

The selected character is entered.

#### Display example

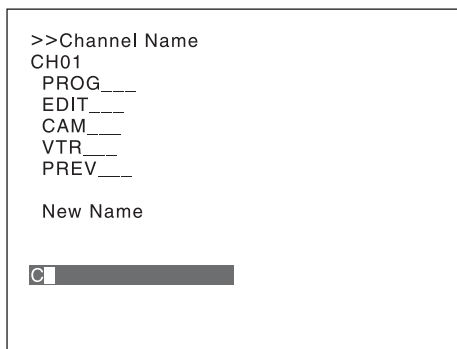

#### 5 Repeat steps 3 and 4 until all the characters are entered, then press the ENTER or Ent button.

The selected characters are confirmed and the display returns to the menu of the upper level.

#### To correct the entered character

Press the Del button. The character on the left side of the cursor is deleted.

## Entering the Channel Number

When selecting a one-digit number, press the button of the channel number.

When selecting a two-digit number, first press the 0 button, then press a two-digit channel number.

#### Channel numbers 91 to 97 assignment

The signal systems to which the internal signal is displayed are assigned to channel numbers 91 to 97. The internal signal of the last signal system is displayed.

**091:** PLUGE signal

**092:** 20% gray signal

**093:** 100% white signal

**094:** Five-step gray scale signal

**095:** Ramp signal

**096:** color-bar signal

**097:** 0% black signal

To cancel the internal signal, select one from the channel numbers 1 to 30.

#### Note

You cannot select channel numbers 91 to 97 in the following cases:

- When the XYZ signal, or the computer signal of HDMI is input
- When [Side by Side] is set to [On]
- When [Wipe] is set to [On]
- When [Butterfly] is set to [On]
- When [Blending] is set to [On]
- When [Pixel Zoom] is set to on

## Aborting Menu Operation

Press the MENU button. The menu of the upper level is displayed.

When the MENU button is pressed in setting mode or during adjustment, the menu returns to the previous setting.

The menu disappears automatically if not operated for about one minute.

---

# Protection of the Setting Values

---

## Protecting the setting values using the [Key Protect]

You can protect the setting values using the [Key Protect] menu.

When the values are protected by [Key Protect], you cannot change the values.

To change the values, set [Key Protect] to [Off].

---

## Protecting the setting values using [Password]

You can protect the menu values using [Password] of [System Configuration].

When the values are protected with a password, you need to enter the password to change the settings.

*For details, see [Password] (page 61).*

---

# Adjustment Using the Menus

---

## Items

The screen menu of this monitor consists of the following items.

### [Adjustment](page 31)

- [Picture Adj]
  - [Auto]
    - [Auto Adjust]
    - [Color Bar]
    - [Restore Factory Data]
    - [Status]
    - [Format]
    - [Matrix]
  - [Manual Adjust]
  - [Copy From]
    - [Preset Value]
    - [Other Monitor]
    - [External Memory]
- [Color Temp Adj]
  - [Manual]
    - [Manual Adjust]
    - [Original Value]
    - [Signal]
      - [Contrast/Bright Hold]
  - [Copy From]
    - [Preset Value]
    - [Other Monitor]
    - [External Memory]
  - [Restore Factory Data]
- [Position Adj]
  - [H Shift]
  - [V Shift]

### [Channel Configuration](page 35)

- [Format]
  - [3G/HD/SD-SDI]
  - [Dual Link HD-SDI]
  - [Composite]
  - [HDMI]
- [Input No]
- [Screen Aspect]
  - [HD]
  - [SD]
    - [DC 2048×1080]
    - [HDMI Auto]
- [Color Temp]
- [Picture Preset]
- [Matrix/Color Profile]

- [Matrix]
  - [HD]
  - [SD]
- [Color Profile]
  - [Color Space]
  - [Gamma]
- [HDMI Auto]
- [Marker Preset]
- [H Shift Offset]
- [Channel Name]
- [NTSC Setup Level]
- [RGB Range]
  - [HD]
  - [DC 2048×1080]
  - [HDMI]
  - [HDMI Auto]
- [1080I/PsF]
  - [24PsF]
  - [25PsF/50I]
  - [30PsF/60I]
- [Film Cadence]
- [Copy From]
  - [Other CH]
  - [Other Monitor]
  - [External Memory]

### **[Auxiliary Setting](page 42)**

- [Native Scan Mode]
- [Aperture Value]
- [Peak White Control]

### **[Function Setting](page 43)**

- [Marker Setting]
  - [Aspect Marker]
    - [Aspect Marker]
    - [Aspect Mode]
    - [Aspect]
    - [Line]
    - [Thickness]
    - [Color]
    - [Bright]
    - [Blanking]
  - [Area Marker 1]
    - [Area Marker 1]
    - [Aspect Mode]
    - [Aspect]
    - [Area Size]
    - [Width]
    - [Height]
    - [Mode]
    - [Thickness]
    - [Color]
    - [Bright]
  - [Area Marker 2] <sup>1)</sup>
  - [Center Marker]
    - [Center Marker]

- [Mode]
- [Color]
- [Bright]
- [H Position]
- [V Position]
- [Copy From]
  - [Preset Value]
  - [Other Monitor]
  - [External Memory]
- [P&P Setting]
  - [Side by Side]
    - [Line Display]
    - [Line Color]
    - [Line Bright]
  - [Wipe]
    - [Line Display]
    - [Line Color]
    - [Line Bright]
    - [Position]
  - [Butterfly]
    - [Line Display]
    - [Line Color]
    - [Line Bright]
    - [Position]
  - [Blending]
    - [Blending Ratio]
- [Pixel Zoom Setting]
  - [Line Color]
- [Gamut Error Display]
  - [Gamut Error Display]
  - [OSD Notification]
  - [OSD Notification Reset]
- [Input Detection]
  - [Detection]
    - [Pixel Threshold]
    - [Signal Level]
    - [SDI YCbCr 10bit]
    - [SDI RGB 10bit]
    - [SDI YCbCr 12bit]
    - [SDI RGB 12bit]
    - [HDMI YCbCr]
    - [HDMI RGB]
- [Post-Process Detection]
  - [Detection]
    - [Pixel Threshold]
    - [Signal Level]
- [Zebra Pattern]
  - [Line]
  - [Modulation]
- [Capture]
  - [Load]
  - [Rename]
  - [Delete]
- [Internal Signal]
- [Function Switch]

1) The item is the same for [Area Marker 1].

## [System Configuration](page 57)

- [Network]
  - [Monitor ID]
  - [Group ID]
  - [Network Setting]
    - [IP Address]
    - [Subnet Mask]
    - [Default Gateway]
      - [Address]
  - [Protocol Setting]
    - [SDCP/SDAP Community]
    - [SDCP Port No]
    - [SDAP Port No]
    - [SDAP Broadcast]
    - [SDAP Broadcast Period]
    - [Acceptable IP Address]
    - [Reset Protocol Setting]
- [Parallel Remote]
  - [Parallel Remote]
    - [1 Pin] to [8 Pin]
- [Power]
  - [Sleep Mode]
  - [Power On Status]
  - [Default CH]
- [On Screen Set]
  - [Input Information]
    - [Format]
    - [Position]
    - [CH No]
      - [Position]
      - [CH Name]
        - [Position]
      - [Scan Mode]
        - [Position]
  - [Closed Caption]
    - [Closed Caption]
      - [Type]
      - [Service 708]
      - [Service 608]
      - [OSD Level]
  - [Audio Level Meter]
    - [Audio CH]
      - [Position]
    - [Transparency]
    - [Peak Hold]
  - [Time Code]
    - [VITC/LTC]
      - [Position]
      - [Level]
  - [Over Range]
- [Password]
  - [Change Password]
  - [Apply Password]
    - [Adjustment]
    - [Channel Configuration]
    - [Auxiliary Setting]
    - [Function Setting]

- [System Configuration]
  - [Individual Item]
  - [File Management]
    - [Controller]
      - [Key Protect]
  - [Date/Time]
  - [Scan Mode Skip]
  - [Screen Saver]
  - [Monitor Upgrade]
    - [Software Version]
    - [Kernel Version]
    - [FPGA Version]
    - [CPLD Version]
    - [Software Upgrade]
    - [Kernel Upgrade]
    - [FPGA Upgrade]
  - [Maintenance]

## [File Management](page 62)

- [Save To]
  - [External Memory]
- [Copy From]
  - [Other Monitor]
    - [External Memory]
- [Delete]
  - [External Memory]
- [Data Maintenance]
  - [Back Up System Data]
  - [Restore System Data]

## [System Status](page 64)

Displays the unit setting status, etc.

*For details on the displayed items, see “[System Status] Menu” (page 64).*

## [Controller](page 66)

- [Network]
  - [Network Setting]
    - [IP Address]
    - [Subnet Mask]
    - [Default Gateway]
      - [Address]
  - [Protocol Setting]
    - [SDCP/SDAP Community]
    - [SDCP Port No]
    - [SDAP Port No]
    - [SDAP Broadcast]
    - [SDAP Broadcast Period]
    - [Reset Protocol Setting]
- [Function Key]
  - [F1] to [F16]
- [Monitor ID Display]
- [Controller Upgrade]
  - [Software Version]
  - [Kernel Version]

[Software Upgrade]  
[Kernel Upgrade]

## [Key Protect](page 69)

### [Adjustment] Menu

Adjusts the picture, color temperature, etc.  
When [Adjustment] is selected, the following menu is displayed.

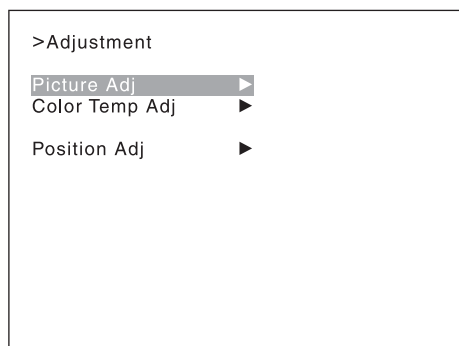

#### Note

This menu is not selectable in the following cases:

- When [Side by Side] is set to [On]
- When [Wipe] is set to [On]
- When [Butterfly] is set to [On]
- When [Blending] is set to [On]

### [Picture Adj]

Adjusts the chroma, phase, matrix, and signal level automatically and contrast, brightness, chroma, and phase to set the preset value to the picture adjustment preset data. When the item is selected, the picture adjustment preset data to be set is displayed.

To change the picture adjustment preset data to be adjusted, you can select from [Preset1], [Preset2], [Preset3], [Preset4], [Preset5], and [Preset(DCI)] in the [Picture Preset] menu (page 37) of the [Channel Configuration] menu.

### [Auto]

Sets the automatic adjustment of chroma, phase, matrix, and signal level.

When the item is selected, the selected preset data is displayed.

You can select this item when the composite signal is displayed.

#### Notes

- To display the composite signal, perform [Auto Adjust] for the signal format, signal system and matrix.

When [Auto Adjust] is performed, the 100 % (white) and 0 % (black) level of the internal signal of the monitor is adjusted equal to the 100 % (white) and 0 % (black) level of the reference signal as well as the chroma, phase and matrix adjustment.

When you make a further adjustment on the chroma and phase after [Auto Adjust], adjust them manually.

- This menu is not selectable when the internal signal or captured frame is displayed.

Submenu	Setting
[Auto Adjust]	Starts automatic adjustment. (It may take some time until automatic adjustment is completed.) An external color-bar signal for the reference is necessary for automatic adjustment (page 31). The chroma data is reset to the default setting [1000]. The phase data is reset to the default setting [000]. <b>To cancel adjustment</b> Press the MENU button.
[Color Bar]	Sets the color-bar signal to input. <ul style="list-style-type: none"><li>• <b>[Full Field 8]:</b> 100% full-field 8-color bars (white, yellow, cyan, green, magenta, red, blue, and black)</li><li>• <b>[SMPTE]:</b> SMPTE standard color bars</li><li>• <b>[EIA]:</b> EIA standard color bars (effective for 480/60i and 575/50i signals only)</li><li>• <b>[Multi Format]:</b> Color bars standardized by SMPTE RP219/ARIB STD-B28</li></ul>
[Restore Factory Data]	Resets the automatic adjustment data of chroma, phase, matrix, and signal level to the default setting. You cannot select this when the setting is the default value. The following message appears. [Restore factory data ?] <ul style="list-style-type: none"><li>• <b>[OK]:</b> To reset the data, press the ENTER (Ent) button.</li><li>• <b>[Cancel]:</b> To cancel, press the MENU button.</li></ul>
[Status]	Displays the status of the automatic adjustment data of the chroma, phase, matrix, and signal level to be adjusted. <ul style="list-style-type: none"><li>• <b>[Not Adjusted]:</b> Displays when the data is not adjusted.</li><li>• <b>[Adjusted]:</b> Displays when the data is adjusted.</li></ul>
[Format]	Displays the signal format and signal system of the automatic adjustment data to be adjusted.
[Matrix]	Displays the matrix of the automatic adjustment data to be adjusted.

### [Manual Adjust]

Adjusts values by turning the PHASE, CHROMA, BRIGHT, and/or CONTRAST knobs. After adjustment,

press the ENTER (Ent) button to confirm the adjusted values.

- **[Phase]:** -150 to +150 (Default value: [000])
- **[Chroma]:** 0000 to 2000 (Default value: [1000])
- **[Bright]:** -500 to +500 (Default value: [000])
- **[Contrast]:** 0000 to 2500 (Default value: [1000] (for [Preset1] to [Preset5]), Default value: [0480] (for [Preset(DCI)]))

**To display no characters on the screen while adjusting manually**

Set the CHAR OFF button to on. The characters disappear. To display characters, set the CHAR OFF button to off.

**To reset the setting to the default**

Press the corresponding MANUAL button. The adjusted value is reset to the default.

**To cancel adjustment**

Press the MENU button. The adjustment data is cleared.

**To confirm adjustment**

Press the ENTER (Ent) button.

**Note**

During adjustment, the screen saver is activated automatically if the operating conditions are met regardless of the setting of the screen saver function.

**[Copy From]**

Copies picture adjustment preset data.

**Notes**

- Automatic adjustment data is not copied.
- Use the BKM-16R with software version 1.6 or higher or BKM-17R to use the [Copy From] function.

Submenu	Setting
[Preset Value]	Copies other data in this monitor. When the item is selected, you can select from [Preset1], [Preset2], [Preset3], [Preset4], [Preset5], or [Preset(DCI)].
[Other Monitor]	Copies data from another monitor.
	<p><b>Note</b></p> <p>Use the BVM-E251/BVM-E171 as a source monitor to use the [Other Monitor] function.</p>
[Monitor ID]	Enter the ID number of the source monitor. When the NETWORK switch is set to PEER TO PEER, this is not selectable. When the ID number is entered, you can select from [Preset1], [Preset2], [Preset3], [Preset4], [Preset5], or [Preset(DCI)].

Submenu	Setting
[External Memory]	Copies data in the USB memory stick, etc.
	<p><b>Note</b></p> <p>Use the USB memory stick, etc. with data stored by the BVM-E251/BVM-E171 to use the [External Memory] function.</p> <p>When the item is selected, the file names in the source USB memory stick, etc. are displayed. When the file is selected, you can select from [Preset1], [Preset2], [Preset3], [Preset4], [Preset5], or [Preset(DCI)].</p>

**[Color Temp Adj]**

Adjusts the color temperature.

When the item is selected, the color temperature data to be adjusted is displayed.

• **Except for the XYZ format signal**

When [D93], [D65], [D61], [D55], or [DCI] data is changed, they are displayed as [D93\*], [D65\*], [D61\*], [D55\*], or [DCI\*].

To change the color temperature data to be adjusted, select [D93], [D65], [D61], [D55], [DCI], [User1], [User2], [User3], [User4], or [User5] in the [Color Temp] menu of the [Channel Configuration] menu.

• **For the XYZ format signal**

When [DCI XYZ] data is changed, it is displayed as [DCI XYZ\*].

To change the color temperature data to be adjusted, select [DCI XYZ], [User XYZ1], [User XYZ2], [User XYZ3], [User XYZ4], or [User XYZ5] in the [Color Temp] menu (page 36) of the [Channel Configuration] menu.

**Note**

If you measure the color temperatures of different display types, such as CRT, LCD, or OLED, by using a common (or general) color analyzer that is based on CIE 1931, and adjust the xy chromaticity to the same value, the appearance may be different because of optical spectrum differences.

To compensate for this difference, the [D93], [D65], [D61], [D55], and [User1] to [User5] settings (except DCI) of the monitor are adjusted by an offset <sup>1)</sup>.

1) The offset value applied (x-0.006, y-0.011) is based on the Judd's function to the CIE 1931 (x, y) value.

**[Manual]**

Adjusts the color temperature manually.

When the item is selected, the color temperature data to be set is displayed.



### Except for the XYZ format signal

When [D93], [D65], [D61], [D55], or [DCI] data is changed, they are displayed as [D93\*], [D65\*], [D61\*], [D55\*], or [DCI\*].

### For the XYZ format signal

When [DCI XYZ] data is changed, it is displayed as [DCI XYZ\*].

When [Contrast/Bright Hold] is set to [Off], the color temperature data are displayed. The contrast data is displayed as the picture preset data [Preset1] to [Preset5] or [Preset(DCI)] set in the [Picture Preset] menu of the [Channel Configuration] menu. To change the type of the picture preset data, select from [Preset1] to [Preset5] or [Preset(DCI)] in the [Picture Preset] menu (page 37) of the [Channel Configuration] menu.

Submenu	Setting
[Manual Adjust]	<p>Adjusts the color temperature using the BRIGHT, CHROMA, PHASE, and/or CONTRAST knobs.</p> <p>When the item is selected, the color temperature adjustment display appears, and the [Red], [Green], and/or [Blue] color temperature data to be adjusted are displayed to allow gain or bias adjustment. Select gain or bias adjustment using the UP/DOWN buttons.</p> <p>The adjustable items and relevant knobs are as follows:</p> <ul style="list-style-type: none"><li>• To adjust [Red] (red): BRIGHT knob</li><li>• To adjust [Green] (green): CHROMA knob</li><li>• To adjust [Blue] (blue): PHASE knob</li><li>• To adjust brightness ([Red], [Green] and [Blue] together): CONTRAST knob</li></ul> <p><b>To hide the characters on the monitor during manual adjustment</b> Set the CHAR OFF button of the controller to on. As the characters on the display are hidden, it becomes easy to adjust the picture. To display the characters, set the CHAR OFF button to off.</p> <p><b>To reset [Red], [Green], and [Blue] to the value before adjustment</b> During [Red], [Green], and [Blue] adjustment, you can press the corresponding MANUAL button to reset to the value before adjustment. Pressing the MANUAL button of CONTRAST resets all [Red], [Green], and [Blue] to the values before adjustment.</p> <p><b>Note</b></p> <p>You cannot reset the setting after you press the ENTER (Ent) button even if you press the MANUAL button.</p> <p><b>To cancel adjustment</b> Press the MENU button. The adjustment data is cleared and the setting returns to the previous value.</p> <p><b>To confirm adjustment</b> Press the ENTER (Ent) button.</p> <p><b>Note</b></p> <p>During adjustment, the screen saver is activated automatically if the operating conditions are met, regardless of the setting of the screen saver function.</p>

Submenu	Setting
[Original Value]	<p>Sets the initial value.</p> <p><b>Except for the XYZ format signal</b>            You can select from [D93], [D65], [D61], [D55], [DCI], [User1], [User2], [User3], [User4], or [User5].            When [D93], [D65], [D61], [D55], or [DCI] data is changed, they are displayed as [D93*], [D65*], [D61*], [D55*], or [DCI*].</p> <p><b>For the XYZ format signal</b>            You can select from [DCI XYZ], [User XYZ1], [User XYZ2], [User XYZ3], [User XYZ4], or [User XYZ5].            When the [DCI XYZ] data is changed, it is displayed as [DCI XYZ*].</p>
[Signal]	<p>Sets the white signal to be used for adjustment.</p> <ul style="list-style-type: none"> <li>• <b>[Internal]:</b> Select when an internal signal is used. The signal is automatically switched in synchronization with the gain and bias adjustments.</li> <li>• <b>[External]:</b> Select when an external input signal is used. Supply a signal to be used when adjusting gain and bias.</li> </ul>
<b>Note</b>	
If [Internal] is selected for the XYZ format signal, the Calibration White signal is displayed.	
[Contrast/Bright Hold]	<p>Sets the contrast and brightness to the adjusted value or center value.</p> <ul style="list-style-type: none"> <li>• <b>[Off]:</b> Sets contrast and brightness to the center values during and after color temperature adjustment.</li> <li>• <b>[On]:</b> Retains the adjusted contrast and brightness values during and after color temperature adjustment.</li> </ul>

### [Copy From]

Copies the other color temperature.

#### Note

Use the BKM-16R with software version 1.6 or higher or BKM-17R to use the [Copy From] function.

Submenu	Setting
[Preset Value]	<p>Copies other data in this monitor.</p> <p><b>Except for the XYZ format signal</b>            When the item is selected, you can select from the following:</p> <ul style="list-style-type: none"> <li>• <b>[D93]:</b> Copies the color temperature of D93.</li> <li>• <b>[D65]:</b> Copies the color temperature of D65.</li> <li>• <b>[D61]:</b> Copies the color temperature of D61.</li> <li>• <b>[D55]:</b> Copies the color temperature of D55.</li> <li>• <b>[DCI]:</b> Copies the color temperature of DCI.</li> <li>• <b>[User1] to [User5]:</b> Copies the color temperature of User1 to User5.</li> </ul> <p>When [D93], [D65], [D61], [D55], or [DCI] data is changed, they are displayed as [D93*], [D65*], [D61*], [D55*], or [DCI*].</p> <p><b>For the XYZ format signal</b>            When the item is selected, you can select from the following:</p> <ul style="list-style-type: none"> <li>• <b>[DCI XYZ]:</b> Copies the color temperature of DCI XYZ.</li> <li>• <b>[User XYZ1] to [User XYZ5]:</b> Copies the color temperature of User XYZ1 to User XYZ5.</li> </ul> <p>When [DCI XYZ] data is changed, it is displayed as [DCI XYZ*].</p>
[Other Monitor]	<p>Copies data from another monitor.</p>
<b>Note</b>	
Use the BVM-E251/BVM-E171 as a source monitor to use the [Other Monitor] function.	
[Monitor ID]	<p>Enter the ID number of the source monitor.</p> <p>When the NETWORK switch is set to PEER TO PEER, this is not selectable.</p> <p><b>Except for the XYZ format signal</b>            When the ID number is entered, you can select from the following:</p> <ul style="list-style-type: none"> <li>• <b>[D93]:</b> Copies the color temperature of D93.</li> <li>• <b>[D65]:</b> Copies the color temperature of D65.</li> <li>• <b>[D61]:</b> Copies the color temperature of D61.</li> <li>• <b>[D55]:</b> Copies the color temperature of D55.</li> <li>• <b>[DCI]:</b> Copies the color temperature of DCI.</li> <li>• <b>[User1] to [User5]:</b> Copies the color temperature of User1 to User5.</li> </ul> <p>When [D93], [D65], [D61], [D55], or [DCI] data is changed, they are displayed as [D93*], [D65*], [D61*], [D55*], or [DCI*].</p>

Submenu	Setting
	<p><b>For the XYZ format signal</b> When the ID number is entered, you can select from the following:</p> <ul style="list-style-type: none"> <li>• <b>[DCI XYZ]:</b> Copies the color temperature of DCI XYZ.</li> <li>• <b>[User XYZ1] to [User XYZ5]:</b> Copies the color temperature of User XYZ1 to User XYZ5.</li> </ul> <p>When [DCI XYZ] data is changed, it is displayed as [DCI XYZ*].</p>

[External Memory] Copies data in the USB memory stick, etc.

**Note**

Use the USB memory stick, etc. with data stored by the BVM-E251/BVM-E171 to use the [External Memory] function.

When the item is selected, the file names in the source USB memory stick, etc. are displayed.

**Except for the XYZ format signal**

When the file is selected, you can select from the following:

- **[D93]:** Copies the color temperature of D93.
- **[D65]:** Copies the color temperature of D65.
- **[D61]:** Copies the color temperature of D61.
- **[D55]:** Copies the color temperature of D55.
- **[DCI]:** Copies the color temperature of DCI.
- **[User1] to [User5]:** Copies the color temperature of User1 to User5.

When [D93], [D65], [D61], [D55], or [DCI] data is changed, they are displayed as [D93\*], [D65\*], [D61\*], [D55\*], or [DCI\*].

**For the XYZ format signal**

When the file is selected, you can select from the following:

- **[DCI XYZ]:** Copies the color temperature of DCI XYZ.
- **[User XYZ1] to [User XYZ5]:** Copies the color temperature of User XYZ1 to User XYZ5.

When [DCI XYZ] data is changed, it is displayed as [DCI XYZ\*].

**Restore Factory Data**

Resets the color temperature to the default setting. You cannot select this when the setting is the default value.

The following message appears to confirm the data reset operation.

[Restore factory data ?]

- **[OK]:** To reset the data, press the ENTER (Ent) button.
- **[Cancel]:** To cancel, press the MENU button.

**[Position Adj]**

Adjusts the position of the picture when the analog signal is input.

When the item is selected, the signal system to be set is displayed.

You can select the item when the composite signal is displayed.

**To hide the characters on the monitor during adjustment**

Set the CHAR OFF button of the controller to on. As the characters on the display are hidden, it becomes easy to adjust the picture. To display the characters, set the CHAR OFF button to off.

**Note**

This menu is not selectable when the internal signal or captured frame is displayed.

Submenu	Setting
[H Shift]	Adjusts the horizontal position of the picture. As the setting increases, the picture moves to the right, and as the setting decreases, the picture moves to the left. (Default value: [000]) Set in the [H Shift Offset] menu (page 37) of the [Channel Configuration] menu when it is necessary to adjust the difference of the horizontal position for different input signals of the same signal system, etc.
[V Shift]	Adjusts the vertical position of the picture. As the setting increases, the picture moves up, and as the setting decreases, the picture moves down. (Default value: [000])

**[Channel Configuration] Menu**

This menu is used for pertaining data to the input signals.

When [Channel Configuration] is selected, the following menus are displayed.

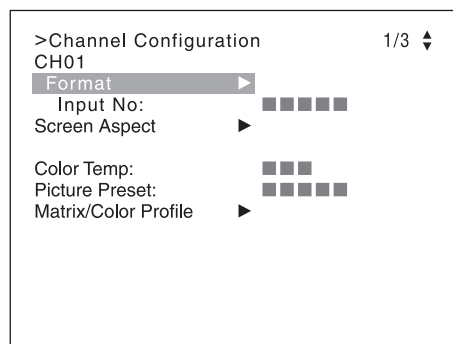

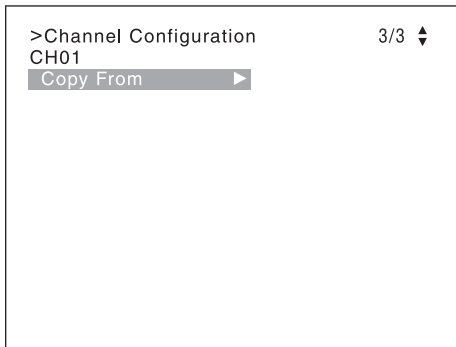
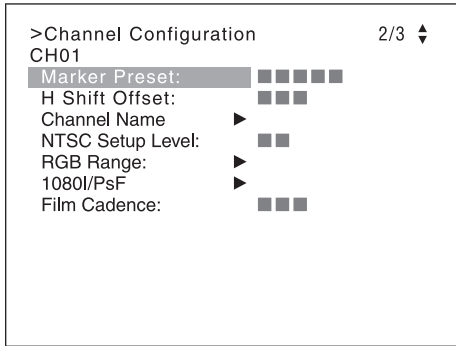

The current channel is displayed.  
Perform the input setting for the selected channel.

### Before setting

Set the input signal for each channel. A channel number (1 to 30) is entered with the numeric buttons (page 27).

#### Note

This menu is not selectable in the following cases:

- When [Side by Side] is set to [On]
- When [Wipe] is set to [On]
- When [Butterfly] is set to [On]
- When [Blending] is set to [On]

Submenu	Setting
[Format]	Sets the input signal type. <i>For details of the setting, see [Format] (page 38).</i>
	<b>Note</b> The default setting is [3G/HD/SD-SDI Auto].

Submenu	Setting
[Input No]	Enters the input connector number if there are two inputs with the same type of input connectors. When [Format] is set to [3G/HD/SD-SDI Auto] or [4:2:2 YCbCr 10bit] or [4:4:4 YCbCr 10bit], [4:4:4 RGB 10bit], [4:4:4 YCbCr 12bit], [4:4:4 RGB 12bit], [4:4:4 XYZ 12bit] of [3G-SDI], [HD/SD-SDI Auto], [SD-SDI], select from the following: <ul style="list-style-type: none"> <li>• [Input1]</li> <li>• [Input2]</li> </ul> When [Format] is set to [4:2:2 YCbCr 10bit] or [4:4:4 YCbCr 10bit], [4:4:4 RGB 10bit], [4:4:4 YCbCr 12bit], [4:4:4 RGB 12bit], [4:4:4 XYZ 12bit] of [Dual Link HD-SDI], [Input1&2] is selected.
[Screen Aspect]	Selects the aspect ratio. <i>For details of the setting, see [Screen Aspect] (page 38).</i>
[Color Temp]	Sets the color temperature. <b>Except for the XYZ format signal</b> Select from the following: <ul style="list-style-type: none"> <li>• [D93]</li> <li>• [D65]</li> <li>• [D61]</li> <li>• [D55]</li> <li>• [DCI]</li> <li>• [User1] to [User5]</li> </ul> When [DCI] is selected, the color temperature is set to $x=0.314$ and $y=0.351$ in the CIE chromaticity coordinate. When [D93], [D65], [D61], [D55], or [DCI] data is changed, they are displayed as [D93*], [D65*], [D61*], [D55*], or [DCI*]. <b>For the XYZ format signal</b> Select from the following: <ul style="list-style-type: none"> <li>• [DCI XYZ]</li> <li>• [User XYZ1] to [User XYZ5]</li> </ul> When [DCI XYZ] data is changed, it is displayed as [DCI XYZ*].

#### Note

If you measure the color temperatures of different display types, such as CRT, LCD, or OLED, by using a common (or general) color analyzer that is based on CIE 1931, and adjust the xy chromaticity to the same value, the appearance may be different because of optical spectrum differences.  
To compensate for this difference, the [D93], [D65], [D61], [D55], and [User1] to [User5] settings (except [DCI]) of the monitor are adjusted by an offset <sup>1)</sup>.

1) The offset value applied ( $x-0.006$ ,  $y-0.011$ ) is based on the Judd's function to the CIE 1931 (x, y) value.

Submenu	Setting
[Picture Preset]	Sets the picture adjustment preset. Select from the following: <ul style="list-style-type: none"> <li>• [Preset1] to [Preset5]</li> <li>• [Preset(DCI)]</li> </ul>
[Matrix/Color Profile]	Sets [Matrix] data (transmission matrix) and [Color Profile] depending on the input signal format.  <i>For details of the setting, see [Matrix/Color Profile] (page 38).</i>
[Marker Preset]	Sets the marker preset data. You can select from [Marker1] to [Marker5]. (Default value: [Marker1])  <i>For setting the marker, see the [Marker Setting] menu (page 43) of the [Function Setting] menu.</i>
[H Shift Offset]	Sets the horizontal picture position when the analog signal is input. You can select when [Format] is set to [Composite Auto], [Composite NTSC], [Composite PAL], or [Composite PAL-M]. Set to -100 to +100 <sup>1)</sup> . (Default value: [000]) 1) When the setting value is out of range, the display of the setting value is changed but the horizontal position of the picture is not changed.  <b>To hide the characters on the monitor during adjustment</b> Set the CHAR OFF button of the controller to on. As the characters on the display are hidden, it becomes easy to adjust the picture. To display the characters, set the CHAR OFF button to off.
[Channel Name]	Sets a channel name. When the item is selected, you can select a preset name or enter a new one. <ul style="list-style-type: none"> <li>• [PROG__]: Program signal</li> <li>• [EDIT__]: Signal from an editor</li> <li>• [CAM__]: Camera signal</li> <li>• [VTR__]: Signal from a VTR</li> <li>• [PREV__]: Preview monitor</li> <li>• [New Name]: Enter a new name.</li> </ul> (Up to 20 characters can be entered.)
[NTSC Setup Level]	Sets the NTSC setup level. You can select when [Format] is set to [Composite Auto] or [Composite NTSC]. <ul style="list-style-type: none"> <li>• [0%]</li> <li>• [7.5%]</li> </ul>
[RGB Range]	Sets the quantization range of the 4:4:4 RGB SDI or HDMI input signal.  <i>For details of the setting, see [RGB Range] (page 41).</i>

Submenu	Setting
[1080I/PsF]	When the 1080i/PsF signal is input, select the display mode. You can select when [Format] is set to [3G/HD/SD-SDI Auto], [HD/SD-SDI Auto], [4:2:2 YCbCr 10bit], [4:4:4 YCbCr 10bit], [4:4:4 RGB 10bit], [4:4:4 YCbCr 12bit], [4:4:4 RGB 12bit], or [4:4:4 XYZ 12bit]. When [1080I] is selected, the I/P conversion signal is displayed. When [1080PsF] is selected, the progressive conversion (PsF to P) signal is displayed. When the 1080PsF signal is input and [1080I] is selected, the display delay is shortened. The signal converted from PsF to P is not displayed and the I/P conversion signal is displayed. When [Format] is set to [3G/HD/SD-SDI Auto] and Payload ID data are superimposed on the SDI signal, 1080i/PsF processing is performed based on the Payload ID data, regardless of the setting value.  <i>For details of the setting, see [1080I/PsF] (page 41).</i>
[Film Cadence]	Sets the film cadence mode. The progressive conversion signal is displayed according to the setting. <ul style="list-style-type: none"> <li>• [Off]: The progressive conversion signal is not displayed in film cadence mode</li> <li>• [2-2]: The progressive conversion signal is displayed when the interlace signal of 2-2 pull-down processing is input</li> <li>• [2-3]: The progressive conversion signal is displayed when the interlace signal of 2-3 pull-down processing is input</li> <li>• [2-3-3-2]: The progressive conversion signal is displayed when the interlace signal of 2-3-3-2 pull-down processing is input</li> </ul>
<b>Notes</b>	
<ul style="list-style-type: none"> <li>• When the 50i interlace signal is input, the mode is automatically set to [2-2] even when [2-3] or [2-3-3-2] is selected.</li> <li>• The signal is not displayed in film cadence mode when the 1080i interlace signal is input and [1080PsF] is selected in the [1080I/PsF] menu. Set to [1080I].</li> <li>• As the signal is displayed in film cadence mode by cadence sequence detection based on the pattern of the input signal, the signal may not be displayed correctly because of the pattern of the input signal.</li> <li>• The signal is not displayed in the film cadence mode when [Side by Side], [Wipe], [Butterfly], or [Blending] is set to [On].</li> </ul>	

Submenu	Setting
[Copy From]	Copies signal setting data from other channel.  <i>For details of the setting, see [Copy From] (page 41).</i>
	<b>Note</b>  Use the controller of BKM-16R with software version 1.6 or higher or BKM-17R to use the [Copy From] function.

## [Format]

Submenu	Setting
[3G/HD/SD-SDI]	Sets the serial digital signal format (Single-link 3G-SDI, HD-SDI or SD-SDI). <ul style="list-style-type: none"> <li>[3G/HD/SD-SDI Auto]: Changes the format automatically according to the Sampling Structure, Bit Depth, Picture and transport scanning method information for Payload ID of SMPTE-352M standard superimposed on the input signals.</li> </ul>
	<b>Note</b>  You can confirm the Payload ID information and the signal format status of the current monitor in [SDI Payload ID Status] (page 65) of the [System Status] menu or using the STATUS button on the controller.  <i>For details on the display using the STATUS button, see "Displaying the Monitor Status Page" (page 70).</i> <ul style="list-style-type: none"> <li>[3G-SDI]: Sets the signal format. Select from [4:2:2 YCbCr 10bit], [4:4:4 YCbCr 10bit], [4:4:4 RGB 10bit], [4:4:4 YCbCr 12bit], [4:4:4 RGB 12bit], [4:4:4 XYZ 12bit].</li> <li>[HD/SD-SDI Auto]: Changes the format automatically according to the format of the input signal.</li> <li>[SD-SDI]</li> </ul>
[Dual Link HD-SDI]	Sets the Dual-link HD-SDI signal format. <ul style="list-style-type: none"> <li>[4:2:2 YCbCr 10bit]</li> <li>[4:4:4 YCbCr 10bit]</li> <li>[4:4:4 RGB 10bit]</li> <li>[4:4:4 YCbCr 12bit]</li> <li>[4:4:4 RGB 12bit]</li> <li>[4:4:4 XYZ 12bit]</li> </ul>

Submenu	Setting
[Composite]	Sets the composite signal format. <ul style="list-style-type: none"> <li>[Auto]: Changes automatically according to the format of the input signal. It will take a few seconds to detect the format of an input signal. It is recommended that a particular format be selected if it is determined.</li> <li>[NTSC]</li> <li>[PAL]</li> <li>[PAL-M]</li> </ul>
[HDMI]	Sets the HDMI signal format. In this manual, the 800 × 600, 1024 × 768, 1280 × 960, 1280 × 1024, and 1400 × 1050 signals are referred to as the HDMI computer signals.  <i>For the signal format to be displayed, see page 84.</i>

## [Screen Aspect]

Submenu	Setting
[HD]	Sets the aspect ratio of the HD signal. <ul style="list-style-type: none"> <li>[16:9]</li> <li>[2.39:1]</li> </ul>
[SD]	Sets the aspect ratio of the SD signal. <ul style="list-style-type: none"> <li>[16:9]</li> <li>[4:3]</li> </ul>
[DC 2048×1080]	Sets the aspect ratio of the digital cinema signal (2048 × 1080). <ul style="list-style-type: none"> <li>[1.896:1]</li> <li>[2.39:1]</li> </ul>
[HDMI Auto]	Sets the manual or automatic setting for the aspect ratio of the HDMI signal. <ul style="list-style-type: none"> <li>[Off]: Select to set the aspect ratio manually with the controller, etc.</li> <li>[On]: Select to set the aspect ratio automatically according to the input signal. The aspect ratio is not set with the controller, etc.</li> </ul>

## [Matrix/Color Profile]

Submenu	Setting
[Matrix]	Sets Matrix data (transmission matrix) depending on the input signal format. Four transmission matrix data are preset and can be selected for the HD or SD input signal respectively.  <i>For the type of the input signal, see "Available Signal Formats" (page 80).</i>

Submenu	Setting
[HD]	<p>Sets Matrix of the HD signal.</p> <ul style="list-style-type: none"> <li>• <b>[ITU-R BT.709]</b>: Select when the signal of the ITU-R BT.709 standard format is input.</li> <li>• <b>[ITU-R BT.601]</b>: Select when the signal of the ITU-R BT.601 standard format is input.</li> <li>• <b>[SMPTE 240M]</b>: Select when the signal of the SMPTE-240M standard format is input.</li> <li>• <b>[ITU-R BT.2020]</b>: Select when the signal of the ITU-R BT.2020 standard format is input.</li> </ul>
[SD]	<p>Sets Matrix of the SD signal.</p> <ul style="list-style-type: none"> <li>• <b>[ITU-R BT.709]</b>: Select when the signal of the ITU-R BT.709 standard format is input.</li> <li>• <b>[ITU-R BT.601]</b>: Select when the signal of the ITU-R BT.601 standard format is input.</li> <li>• <b>[SMPTE 240M]</b>: Select when the signal of the SMPTE-240M standard format is input.</li> <li>• <b>[ITU-R BT.2020]</b>: Select when the signal of the ITU-R BT.2020 standard format is input.</li> </ul>

Submenu	Setting
[Color Profile]	<p>Sets the color profile (color space and gamma) to be used.</p> <p>There are nine Color Profile data items in which the color space and gamma have been preset and user channel data item in which Color Space (color space) and Gamma (gamma) can be selected for each individual channel.</p> <ul style="list-style-type: none"> <li>• <b>Preset data:</b> [BVM SMPTE-C], [BVM EBU], [ITU-R BT.709], [DCI], [E251 Native] ([E171 Native]), [ITU-R BT.2020], [S-GAMUT/S-LOG2], [S-GAMUT3.Cine/S-LOG3], [S-GAMUT3/S-LOG3]</li> <li>• <b>Selectable data:</b> [User CH01] to [User CH30] (the currently selected channel number is displayed)</li> </ul> <p>The following shows the setting for color space/gamma of the Color Profile data.</p> <ul style="list-style-type: none"> <li>• [BVM SMPTE-C]: [SMPTE-C] / [CRT BVM]</li> <li>• [BVM EBU]: [EBU] / [CRT BVM]</li> <li>• [ITU-R BT.709]: [ITU-R BT.709] / [2.4]</li> <li>• [DCI]: [DCI-P3] / [2.6]</li> <li>• [E251 Native] ([E171 Native]): [E251 Native] ([E171 Native]) / [2.2]</li> <li>• [ITU-R BT.2020]: [ITU-R BT.2020] / [2.4]</li> <li>• [S-GAMUT/S-LOG2]: [S-GAMUT/S-GAMUT3] / [S-LOG2(SDR)]</li> <li>• [S-GAMUT3.Cine/S-LOG3]: [S-GAMUT3.Cine] / [S-LOG3(SDR)]</li> <li>• [S-GAMUT3/S-LOG3]: [S-GAMUT/S-GAMUT3] / [S-LOG3(SDR)]</li> <li>• [User CH01] to [User CH30]: Select in the [Color Space] menu / Select in the [Gamma] menu</li> </ul>

#### Notes

- When setting [CRT BVM] gamma data for [User CH01] to [User CH30], first select [SMPTE-C] or [EBU] in the [Color Space] menu.
- The [Gamma] setting is fixed at [2.6] when an XYZ format signal is input.
- Set the [Color Space] menu to [DCI-P3] when an XYZ format signal is input.
- When [HDMI Auto] is set to [On] in the [Matrix/Color Profile] menu, [Color Profile] is automatically set and the setting value cannot be changed when the HDMI signal is input.

Submenu	Setting
	<p><b>Color Profile data</b></p> <ul style="list-style-type: none"> <li>• <b>[BVM SMPTE-C]</b>: Displays with the color space and gamma of BVM SMPTE-C phosphor CRT.</li> <li>• <b>[BVM EBU]</b>: Displays with the color space and gamma of BVM EBU phosphor CRT.</li> <li>• <b>[ITU-R BT.709]</b>: Displays with the color space of three primary color chromaticity points provided by ITU-R BT.709 and gamma 2.4.</li> <li>• <b>[DCI]<sup>1)</sup></b>: Displays with the color space of three primary color chromaticity points provided by SMPTE RP 431-2.</li> <li>• <b>[E251 Native] ([E171 Native])</b>: Displays with the color space of the BVM-E251 (BVM-E171) individual three primary color chromaticity points. This is the widest color space setting of the signal reproduced by the BVM-E251 (BVM-E171).</li> <li>• <b>[ITU-R BT.2020]</b>: Displays with the color space of three primary color chromaticity points provided by ITU-R BT.2020 and gamma [2.4].</li> <li>• <b>[S-GAMUT/S-LOG2]</b>: Displays with the color space of the transmission gamma S-Log2 and the wide color space mode S-Gamut which is available for the output signal of F65 or PMW-F55/F5 CineAlta 4K Camera, etc.</li> <li>• <b>[S-GAMUT3.Cine/S-LOG3]</b>: Displays with the color space of the transmission gamma S-Log3 and the wide color space mode S-Gamut3.Cine which is available for the output signal of F65 or PMW-F55/F5 CineAlta 4K Camera, etc.</li> <li>• <b>[S-GAMUT3/S-LOG3]</b>: Displays with the color space of the transmission gamma S-Log3 and the wide color space mode S-Gamut3 which is available for the output signal of F65 or PMW-F55/F5 CineAlta 4K Camera, etc.</li> <li>• <b>[User CH01] to [User CH30]</b>: Select when the color space and gamma are to be set individually depending on the currently selected channel.</li> </ul> <p>1) Three primary color chromaticity points provided by SMPTE RP 431-2 are not covered in full.</p>

Submenu	Setting
[Color Space]	<p>Select the color space when [User CH01] to [User CH30] is selected in the [Color Profile] menu.</p> <ul style="list-style-type: none"> <li>• <b>[SMPTE-C]</b>: Color space of three primary color chromaticity points provided by the SMPTE-C standard</li> <li>• <b>[EBU]</b>: Color space of three primary color chromaticity points provided by the EBU standard</li> <li>• <b>[ITU-R BT.709]</b>: Color space of three primary color chromaticity points provided by the ITU-R BT.709 standard</li> <li>• <b>[DCI-P3]<sup>1)</sup></b>: Color space of three primary color chromaticity points provided by SMPTE RP 431-2</li> <li>• <b>[E251 Native] ([E171 Native])</b>: Color space of the BVM-E251 (BVM-E171) individual three primary color chromaticity points</li> <li>• <b>[ITU-R BT.2020]</b>: Color space of three primary color chromaticity points provided by the [ITU-R BT.2020] standard</li> <li>• <b>[S-GAMUT/S-GAMUT3]</b>: Color space of the wide color space mode, which is available for the F65 or PMW-F55/F5 CineAlta 4K Camera, etc.</li> <li>• <b>[S-GAMUT3.Cine]</b>: Color space of the wide color space mode, which is available for the F65 or PMW-F55/F5 CineAlta 4K Camera, etc.</li> </ul> <p>1) Chromaticity points of SMPTE RP 431-2, ITU-R BT.2020, S-Gamut/S-Gamut3, and S-Gamut3.Cine are not covered in full.</p> <p>When [HDMI Auto] is set to [On] in the [Matrix/Color Profile] menu, a color space detected from the input signal is set and the setting value cannot be changed when the HDMI signal is input.</p>



Submenu	Setting
[Gamma]	<p>Select the gamma when [User CH01] to [User CH5] is selected in the [Color Profile] menu.</p> <ul style="list-style-type: none"> <li>• <b>[CRT BVM]</b>: Gamma curve of the BVM-D or BVM-A series</li> <li>• <b>[2.2]</b>: Gamma curve 2.2</li> <li>• <b>[2.4]</b>: Monitor gamma provided by ITU-R BT.1886</li> <li>• <b>[2.6]</b>: Gamma curve 2.6</li> <li>• <b>[S-LOG2(SDR)]</b>: Log gamma, which is available for the F65 or PMW-F55/F5 CineAlta 4K Camera, etc.</li> <li>• <b>[S-LOG3(SDR)]</b>: Log gamma, which is available for the F65 or PMW-F55/F5 CineAlta 4K Camera, etc.</li> </ul>
	<p><b>Notes</b></p> <ul style="list-style-type: none"> <li>• The gamma is preset to [2.4] that is provided by ITU-R BT.1886 at the factory. With this setting, dark portions may be seen darker than with conventional CRT or LCD monitors. If you wish to obtain the same gamma as that when using a conventional CRT or LCD monitor, set this item to [CRT BVM] or [2.2]. If blocked-up shadows are seen, adjust the brightness for optimum viewing of black portions.</li> <li>• The [Gamma] setting is fixed at [2.6] when an XYZ format signal is input.</li> <li>• The factory preset black luminance of the [CRT BVM] setting in the Gamma menu is the same as the factory preset value for a BVM-D or BVM-A series monitor.</li> <li>• Adjust the brightness (black level) according to the ambient light and the black level of the image to be reproduced. Adjust the contrast (white level) according to the ambient light.</li> <li>• When [S-LOG3(SDR)] is selected, you can confirm the video signal up to a maximum of 1500 % (approx.) within the range of the maximum peak luminance by adjusting the contrast. Signals higher than that will be clipped.</li> </ul>
[HDMI Auto]	<p>Sets the manual or automatic setting for the transmission matrix and color space of the HDMI signal.</p> <ul style="list-style-type: none"> <li>• <b>[Off]</b>: Select to use the value set in the [HD] or [SD] menu for the transmission matrix and the value set in the [Color Profile] menu for the color space.</li> <li>• <b>[On]</b>: Select to set the transmission matrix and color space automatically according to the input signal.</li> </ul>

## [RGB Range]

Submenu	Setting
[HD]	<p>Sets the quantization range when a 4:4:4 RGB SDI signal is input and the signal system is 1920 × 1080 or 1280 × 720.</p> <ul style="list-style-type: none"> <li>• <b>[Full]</b>: 0 (black level) to 1023 (10bit)/4095 (12bit) (white level)</li> <li>• <b>[Limit]</b>: 64(10bit)/256 (12bit) (black level) to 940 (10bit)/3760 (12bit) (white level)</li> </ul>
[DC 2048×1080]	<p>Sets the quantization range when a 4:4:4 RGB SDI signal is input and the signal system is 2048 × 1080.</p> <ul style="list-style-type: none"> <li>• <b>[Full]</b>: 0 (black level) to 1023 (10bit)/4095 (12bit) (white level)</li> <li>• <b>[Limit]</b>: 64 (10bit)/256 (12bit) (black level) to 940 (10bit)/3760 (12bit) (white level)</li> </ul>
[HDMI]	<p>Sets the display mode for the HDMI signal.</p> <ul style="list-style-type: none"> <li>• <b>[Full]</b>: 0 (black level) to 255 (8bit)/1023 (10bit)/4095 (12bit) (white level)</li> <li>• <b>[Limit]</b>: 16 (8bit)/64 (10bit)/256 (12bit) (black level) to 235 (8bit)/940 (10bit)/3760 (12bit) (white level)</li> </ul>
[HDMI Auto]	<p>Sets the manual or automatic setting for the quantization range of the HDMI signal.</p> <ul style="list-style-type: none"> <li>• <b>[Off]</b>: Select to use the quantization range set in the [HDMI] menu.</li> <li>• <b>[On]</b>: Select to set the quantization range automatically according to the input signal</li> </ul>

## [1080I/PsF]

Submenu	Setting
[24PsF]	<p>Sets the display mode for the 1080/24PsF signal.</p> <ul style="list-style-type: none"> <li>• [1080I]</li> <li>• [1080PsF]</li> </ul>
[25PsF/50I]	<p>Sets the display mode for the 1080/25PsF, 50i signal.</p> <ul style="list-style-type: none"> <li>• [1080I]</li> <li>• [1080PsF]</li> </ul>
[30PsF/60I]	<p>Sets the display mode for the 1080/30PsF, 60i signal.</p> <ul style="list-style-type: none"> <li>• [1080I]</li> <li>• [1080PsF]</li> </ul>

## [Copy From]

Submenu	Setting
[Other CH]	<p>Copies other data in this monitor. When the item is selected, you can designate the channel to be copied.</p>

Submenu	Setting
[Other Monitor]	Copies data from other monitor.
	<p><b>Note</b></p> <p>Use the BVM-E251/BVM-E171 as a source monitor to use the [Other Monitor] function.</p>
[Monitor ID]	<p>Enters the ID number of the source monitor.</p> <p>When the NETWORK switch is set to PEER TO PEER, this is not selectable.</p> <p>When the item is selected, you can designate the source monitor.</p> <p>When the ID number is entered, you can designate the channel to be copied.</p>
[Copy from External Memory]	<p>Copies data in the USB memory stick, etc.</p> <p>Use the USB memory stick, etc. with data stored by the BVM-E251/BVM-E171 to use the [Copy from External Memory] function.</p> <p>When the item is selected, the file names in the source USB memory stick, etc. are displayed.</p> <p>When the file is selected, you can enter the channel number in the selected file.</p>

## [Auxiliary Setting] Menu

This menu is used for setting the monitor condition such as the aperture modification and decode mode. When [Auxiliary Setting] is selected, the following menu is displayed.

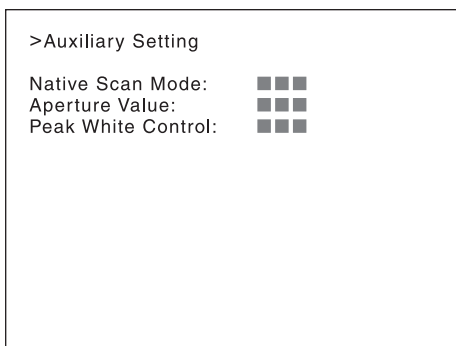

Submenu	Setting
[Native Scan Mode]	<p>You can set the picture display type for the native scan mode according to the input signal.</p> <p>You can select [×1] or [×2], which differ in picture display size, to map the pixels of the signal to the panel in one-to-one mode, or [Aspect Correction].</p> <ul style="list-style-type: none"> <li>• <b>[Aspect Correction]:</b> An SD signal of non-square pixels (the number of H pixels of the signal system is 720 or 1440) or a 640 × 480 SD signal of HDMI video is displayed correctly by scaling processing of doubling for the V direction and correct aspect ratio for the H direction, and the picture is also optimized and displayed by modifying the aperture coefficient value, filter coefficient value, etc.</li> <li>• [×1]: Input signal display without conversion</li> <li>• [×2]: Input signal display doubled</li> </ul> <p><i>For selecting [Aspect Correction], [×1], or [×2], see "Picture Display Size" on page 86. For the display of the native scan mode, see "Display of the Native Scan Mode" (page 42).</i></p>
	<p><b>Notes</b></p> <ul style="list-style-type: none"> <li>• When an HD signal or the computer signal of HDMI is input, the signal is displayed in [×1] mode, even if the mode is set to [Aspect Correction] or [×2].</li> <li>• When you select [Aspect Correction] and set [Native Scan] to [On] for SD signal input, [Aperture] is set to [On] (factory setting).</li> </ul>
[Aperture Value]	<p>Sets the aperture modification value.</p> <p>Sets to 000 to 200.</p> <p>(Default value: [090] (when the signal is displayed in [Aspect Correction] mode of the native display))</p> <p>(Default value: [100] (when the signal is displayed in modes other than [Aspect Correction] of the native display))</p>
[Peak White Control]	<p>When the brightness or contrast is increased using the brightness or contrast adjustment, the picture may be clipped because of the dynamic range of the circuit. Sets whether or not to control the signal gain automatically according to the setting value of the brightness or contrast to prevent such clipping ([Off] or [On]).</p>

## Display of the Native Scan Mode

### Notes

- The native scan is not selectable in the following cases:
  - When the input signal has no sync signal
  - When [Side by Side] is set to [On]

- When [Pixel Zoom] is set to on
- When the HDMI computer signal is input (The native scan is displayed regardless of the setting.)
- When a digital cinema signal (2048 × 1080) is input and the internal signal is displayed ([Native Scan] is set to [Off] and the normal scan is displayed regardless of the setting.)
- When the signal system is the SD signal of 720 × 576, [Native Scan Mode] is set to [Aspect Correction] or [×2] and the internal signal is displayed ([Native Scan] is set to [Off] and the normal scan is displayed regardless of the setting.)

### Display of the input signal system 2048 × 1080

When the input signal system is 2048 × 1080 and the native scan mode is selected, you can display no display area of the left and right sides over the H size (1920) by sliding the picture with the PHASE knob of the controller. You can restore the display position to the center by pressing the MANUAL button of PHASE on the controller.

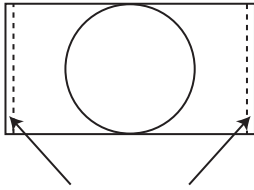

Displayed by sliding the picture with the PHASE knob of the controller.

#### Note

The set position is held even when the system is changed to another input signal system.

### Display of the input signal system 576/50i or 576/50P

When the input signal system is the SD signal of 720 × 576 and [Native Scan Mode] is set to [×2] or [Aspect Correction], you can display no display area of the upper and lower sides over the V size (1080) by sliding the picture with the UP/DOWN button of the controller. And when the input signal is the same as above and [Native Scan Mode] is set to [Aspect Correction] and the aspect ratio is 16:9, you can display no display area of the left and right sides over the H size (1920) by sliding the picture with the PHASE knob of the controller. You can restore the display position to the center by pressing the MANUAL button of PHASE on the controller.

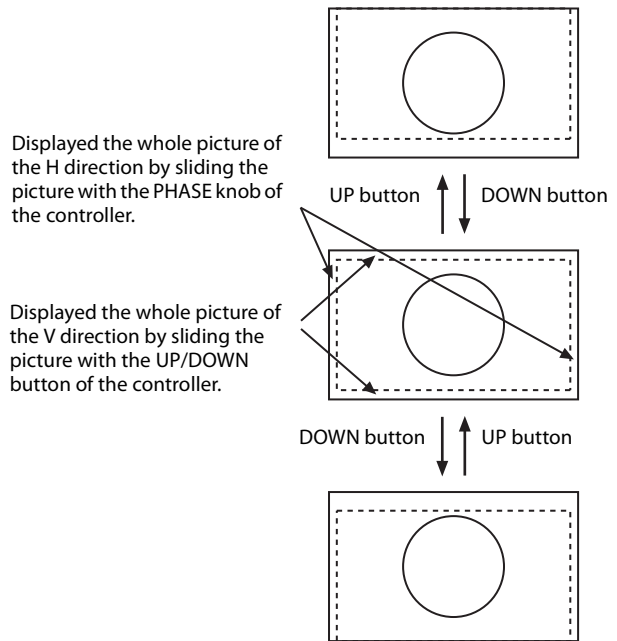

#### Note

The set position is held even when the system is changed to another input signal system.

## [Function Setting] Menu

This menu is used to set the function related to the picture display.

When [Function Setting] is selected, the following menu is displayed.

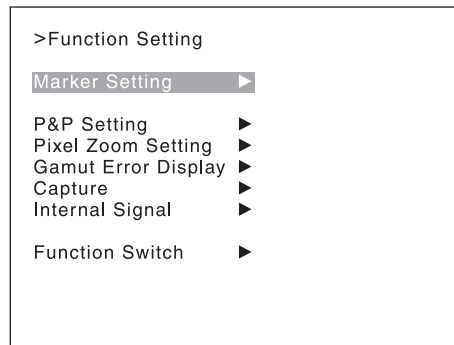

### [Marker Setting]

Sets whether or not to display the marker when the MARKER button is pressed. Also sets the display mode. When the item is selected, the marker preset data to be set is displayed. To change the marker preset data to be adjusted, you can select from [Marker1], [Marker2], [Marker3], [Marker4], and [Marker5] in the [Marker Preset] menu (page 37) of the [Channel Configuration] menu.

## To hide the characters on the monitor during setting

Set the CHAR OFF button of the controller to on. As the characters on the display are hidden, it becomes easy to adjust the picture. To display the characters, set the CHAR OFF button to off.

### [Aspect Marker]

Sets the aspect marker display.



Submenu	Setting
[Aspect Marker]	Sets whether or not to display the aspect marker when the MARKER button is pressed ([Off] or [On]).
[Aspect Mode]	Sets the aspect ratio of the aspect marker. You can select from [16:9], [15:9], [14:9], [13:9], [4:3], [2.39:1], [2.35:1], [1.85:1], [1.66:1], [1.896:1], or [Variable].
[Aspect]	Sets the aspect ratio of the aspect marker when [Variable] is selected in [Aspect Mode]. Set to 1.00:1 to 3.00:1. (Default value: [1.78]:1)
[Line]	Sets whether or not to display the line of the aspect marker ([Off] or [On]).
[Thickness]	Sets the thickness of the aspect marker. Set from [1dot] to [5dot]. (Default value: [2dot])
[Color]	Sets the color of the aspect marker. You can select from [White] (white), [Red] (red), [Green] (green), [Blue] (blue), [Yellow] (yellow), [Cyan] (cyan), or [Magenta] (magenta).
[Bright]	Sets the luminance of the aspect marker. You can select from [High] (bright) or [Low] (dark).
[Blanking]	Sets the blanking outside the area of the aspect marker. <ul style="list-style-type: none"> <li>• [Off]: Blanking is released.</li> <li>• [Black]: Blanking is applied.</li> <li>• [Half]: Half blanking is applied.</li> </ul>

### [Area Marker 1]

Sets the area marker 1.

Submenu	Setting
[Area Marker 1]	Sets whether or not to display the area marker 1 when the MARKER button is pressed ([Off] or [On]).

Submenu	Setting
[Aspect Mode]	Sets the aspect ratio of the area marker 1. You can select from [16:9], [15:9], [14:9], [13:9], [4:3], [2.39:1], [2.35:1], [1.85:1], [1.66:1], [1.896:1], or [Variable].
<b>Note</b>	
	When [Variable(dot)] is selected in [Area Size], the size of the area marker 1 is set in pixel unit of the input signal and the [Aspect Mode] setting becomes invalid.
[Aspect]	Sets the aspect ratio of the area marker 1 when [Variable] is selected in [Aspect Mode]. Set to 1.00:1 to 3.00:1. (Default value: [1.78]:1)
[Area Size]	Sets the size of the area marker 1. You can select from [80%], [88%], [90%], [93%], [Variable(%)], or [Variable(dot)].
[Width]	Sets the width of the area marker 1 when [Area Size] is set to [Variable(%)] or [Variable(dot)]. <b>When [Variable(%)] is selected</b> Set to 050 to 100 (%). (Default value: [080]) <b>When [Variable(dot)] is selected</b> Set to 0360 to 2048 (dot). (Default value: [0512])
[Height]	Sets the height of the area marker 1 when [Area Size] is set to [Variable(%)] or [Variable(dot)]. <b>When [Variable(%)] is selected</b> Set to 050 to 100 (%). (Default value: [080]) <b>When [Variable(dot)] is selected</b> Set to 0240 to 1080 (dot). (Default value: [0384])

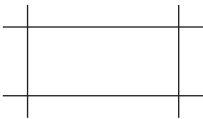
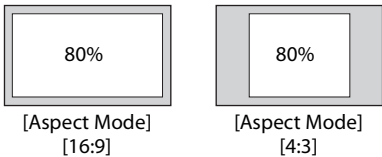
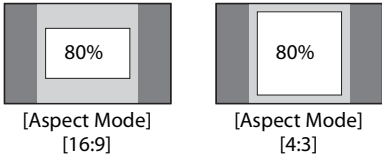
Submenu	Setting
[Mode]	Sets the shape of the area marker 1. You can select from [Shape A], [Shape B], or [Shape C]. <ul style="list-style-type: none"> <li>[Shape A]  </li> <li>[Shape B]  </li> <li>[Shape C]  </li> </ul>
<p><b>Note</b></p> <p>The size of the area is as follows depending on the [Aspect Mode] and [16:9] [On]/[Off] setting. Example: [Area Size] [80%], [Aspect Mode] [16:9] or [4:3]</p> <p>With 16:9</p>  <p>With 4:3</p> 	
[Thickness]	Sets the thickness of the area marker 1. Set from [1dot] to [5dot]. (Default value: [2dot])
[Color]	Sets the color of the area marker 1. You can select from [White] (white), [Red] (red), [Green] (green), [Blue] (blue), [Yellow] (yellow), [Cyan] (cyan), or [Magenta] (magenta).
[Bright]	Sets the luminance of the area marker 1. You can select from [High] (bright) or [Low] (dark).

### [Area Marker 2]

Sets the area marker 2.

The set items are the same as for [Area Marker 1] (page 44).

### [Center Marker]

Sets the center marker.

Submenu	Setting
[Center Marker]	Sets whether or not to display the center marker ([Off] or [On]).
[Mode]	Sets the display mode of the center marker. You can select from [Short] (short) or [Long] (long).
[Color]	Sets the color of the center marker. You can select from [White] (white), [Red] (red), [Green] (green), [Blue] (blue), [Yellow] (yellow), [Cyan] (cyan), or [Magenta] (magenta).
[Bright]	Sets the luminance of the center marker. You can select from [High] (bright) or [Low] (dark).

### [H Position]

Sets the horizontal position of the marker.

Set from -65 (leftward) to +65 (rightward). (Default value: [00])

### [V Position]

Sets the vertical position of the marker.

Set from -35 (downward) to +35 (upward). (Default value: [00])

### [Copy From]

Copies the other marker preset data.

#### Note

Use the BKM-16R with software version 1.6 or higher or BKM-17R to use the [Copy From] function.

Submenu	Setting
[Preset Value]	Copies other data in this monitor. When the item is selected, you can select from [Marker1], [Marker2], [Marker3], [Marker4], or [Marker5].
[Other Monitor]	Copies data from another monitor.
<p><b>Note</b></p> <p>Use the BVM-E251/BVM-E171 as a source monitor to use the [Other Monitor] function.</p>	
[Monitor ID]	Enter the ID number of the source monitor. When the NETWORK switch is set to PEER TO PEER, this is not selectable. When the ID number is entered, you can select from [Marker1], [Marker2], [Marker3], [Marker4], or [Marker5].

Submenu	Setting
[External Memory]	Copies data in the USB memory stick, etc.
	<p><b>Note</b></p> <p>Use the USB memory stick, etc. with data stored by the BVM-E251/BVM-E171 to use the [External Memory] function.</p> <p>When the item is selected, the file names in the source USB memory stick, etc. are displayed. When the file is selected, you can select from [Marker1], [Marker2], [Marker3], [Marker4], or [Marker5].</p>

## Displaying the Area Marker or Aspect Marker

- 1 Input the signal.
- 2 Select the channel.
- 3 Set the marker preset data ([Marker1] to [Marker5]) to display in the [Marker Preset] menu (page 37) of the [Channel Configuration] menu.
- 4 Set the marker to display in the [Marker Setting] menu (page 43) of the [Function Setting] menu for the preset data set in step 3.
- 5 Select the marker mode ([Marker], [Aspect Marker], [Area Marker 1], [Area Marker 2], [Center Marker], [Aspect Marker-Line], [Aspect Blanking-Half], or [Aspect Blanking-Black]) with the function button <sup>1)</sup> of the controller or in the [Function Switch] menu (page 52) of the [Function Setting] menu and set it to [On].

1) Each function of the marker is assigned to the function button of the controller in the [Function Key] menu (page 67) of the [Controller] menu.

### When the MARKER button is set to on

All the markers that are set to [On] in the [Marker Setting] menu of the [Function Setting] menu are displayed.

The MARKER button lights.

### To display the aspect marker

Set the button of the marker mode that you wish to display ([Aspect Marker], [Aspect Marker-Line], [Aspect Blanking-Half], or [Aspect Blanking-Black]) to on.

The MARKER, Aspect Marker, and the pressed button light.

### To display the area marker 1, area maker 2, or center marker

Set the button of the marker that you wish to display ([Area Marker 1], [Area Marker 2], or [Center Marker]) to on.

The MARKER and the pressed button light.

### To cancel the marker display

Set the MARKER button to off.

#### Note

Use the BKM-16R with software version 1.6 or higher or BKM-17R to assign [Center Marker], [Aspect Marker-Line], [Aspect Blanking-Half], or [Aspect Blanking-Black] to a function button of the controller.

### [P&P Setting]

Sets the multi display setting.

### [Side by Side]

Sets the side by side display.

Submenu	Setting
[Line Display]	Sets display mode of the boundary line. <ul style="list-style-type: none"> <li>• [Off]: Not displayed.</li> <li>• [On]: Always displayed.</li> </ul>
[Line Color]	Sets the boundary line color of two pictures. You can select from [White] (white), [Red] (red), [Green] (green), [Blue] (blue), [Yellow] (yellow), [Cyan] (cyan), [Magenta] (magenta), or [Black] (black).
[Line Bright]	Sets the luminance of the boundary line. You can select from [High] (bright) or [Low] (dark).

### [Wipe]

Sets the wipe display.

Submenu	Setting
[Line Display]	Sets display mode of the boundary line. <ul style="list-style-type: none"> <li>• [Auto]: Appears when the position of the boundary line is set and disappears after a while.</li> <li>• [On]: Always displayed.</li> <li>• [Off]: Not displayed.</li> </ul>
[Line Color]	Sets the boundary line color. You can select from [White] (white), [Red] (red), [Green] (green), [Blue] (blue), [Yellow] (yellow), [Cyan] (cyan) or [Magenta] (magenta), or [Black] (black).
[Line Bright]	Sets the luminance of the boundary line. You can select from [High] (bright) or [Low] (dark).

Submenu	Setting
[Position]	Sets the position of the boundary line. Set from -100 (leftward) to +100 (rightward). (Default value: [000])

### [Butterfly]

Sets the butterfly display.

Submenu	Setting
[Line Display]	Sets display mode of the boundary line. <ul style="list-style-type: none"> <li>• [Off]: Not displayed.</li> <li>• [On]: Always displayed.</li> </ul>
[Line Color]	Sets the boundary line color. You can select from [White] (white), [Red] (red), [Green] (green), [Blue] (blue), [Yellow] (yellow), [Cyan] (cyan) or [Magenta] (magenta), or [Black] (black).
[Line Bright]	Sets the luminance of the boundary line. You can select from [High] (bright) or [Low] (dark).
[Position]	Sets the position of the boundary line. Set from -100 to +100. (Default value: [000])

### [Blending]

Sets the blending display.

Submenu	Setting
[Blending Ratio]	Sets the blending ratio when two images are mixed. Set from 000% (Signal A disappears) to 100% (Signal B disappears). (Default value: [050])

## Displaying Two Signals on One Screen

Two input signals are output on the monitor. You can select the display mode from [Side by Side] (side by side), [Wipe] (wipe), [Butterfly] (butterfly), and [Blending] (blending). This is useful for adjusting the color or comparing two pictures.

You can input the file loaded in the [Capture] menu (page 50) of the [Function Setting] menu.

- [Side by Side] (side by side)

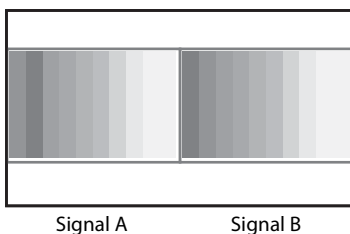

Two pictures are displayed side by side.

- [Wipe] (wipe)

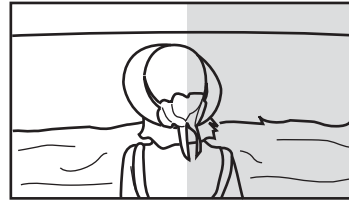

Left and right pictures connected at the boundary position are displayed.

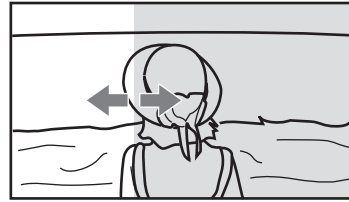

Signal A Signal B

The boundary line of the left and right area is changed with the PHASE knob of the controller.

- [Butterfly] (butterfly)

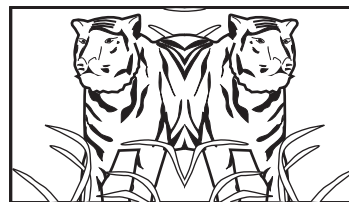

The right picture is a left-right reversal picture of the left picture.



Signal A Signal B

The display range of the picture is changed with the PHASE knob of the controller.

- [Blending] (blending)

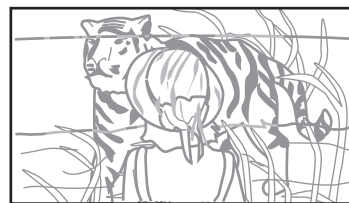

Signal A and Signal B

A picture that superimposes signal A and signal B is displayed. The mixed ratio of two input signals is changed with the PHASE knob of the controller.

### Notes

- You cannot select the same channel number as channels for signal A and signal B. Set a different channel number of the different input for signal A and signal B.
- When the wipe or blending mode is used, signal A and signal B should be genlocked to synchronize with each other.

- When signal A and signal B are not the same signal format and signal system, the pictures may not be displayed correctly.
- The input of signal A is not changed in the multi display.
- The internal signal is not displayed in the multi display.
- The captured picture data is not used to display as signal A and signal B at the same time.
- The signals are not displayed in the multi display mode when [Pixel Zoom] is set to on.
- The color space and gamma setting for signal A is applied in the multi display.

**1** Select the channel number and set the input signal to display as signal A.

**2** Select the display mode of Picture&Picture ([Side by Side], [Wipe], [Butterfly], or [Blending]) with the function button <sup>1)</sup> of the controller or in the [Function Switch] menu (page 52) of the [Function Setting] menu and set it to [On].

**3** Select the channel number and set the input signal to display as signal B.

The channel for signal B is set to CH01 at the factory setting.

**Note**

When the picture is displayed in wipe, butterfly, or blending mode, set signal A and signal B to the input signal of the same signal format and signal system to compare the picture correctly, and set to the native scan mode (page 52).

1) Each function of Picture&Picture is assigned to each function button of the controller in the [Function Key] menu (page 67) of the [Controller] menu.

**To display the captured picture data file**

You can use a captured picture other than the picture selected by designating the channel number as signal A and signal B.

Instead of setting the channel number in step1 or step3, press the CAPTURE LOAD button of the controller or select [Load] in the [Capture] menu (page 50) of the [Function Setting] menu.

**Note**

When the captured picture data file is used in wipe or blending mode, input a 3G/HD-SDI signal for another signal. When a signal not available for capture other than the 3G/HD-SDI signal is input, the picture will not be displayed correctly.

**To end the multi display**

Set [Side by Side], [Wipe], [Butterfly], or [Blending] to [Off] in the [Function Switch] menu (page 52) of the [Function Setting] menu, or set each function button of the controller to off.

**[Pixel Zoom Setting]**

Sets the pixel zoom.

Submenu	Setting
[Line Color]	Sets the boundary line color. You can select from [White] (white), [Red] (red), [Green] (green), [Blue] (blue), [Yellow] (yellow), [Cyan] (cyan) or [Magenta] (magenta), or [Black] (black).

**Magnifying the Picture (Pixel Zoom)**

As part of the picture is magnified up to 8 times (up to 4 times when the display magnification of the native scan is [×2]) without scaling processing, this is convenient for confirming a minute of the signal. This functions in native scan mode.

**Note**

[Pixel Zoom] is not set to on in the following cases:

- When the menu, monitor status page, or list of the functions assigned to the function buttons is displayed
- When [Side by Side], [Wipe], [Butterfly], or [Blending] is set to [On]
- When the internal signal is displayed
- When the input signal has no sync signal

**1** Set [Native Scan] to [On] by pressing the NATIVE SCAN button of the controller or in the [Function Switch] menu (page 52) of the [Function Setting] menu.

**2** Display the picture and set to on by pressing the PIXEL ZOOM button of the controller.

The cursor is displayed.

**Note**

When [Native Scan Mode] is set to [Aspect Correction] and [Pixel Zoom] is set to on for SD signal input, [Native Scan Mode] is set to [×2].

**To cancel the cursor display and return to the previous screen**

Press the MENU button of the controller.

**3** Select the cursor size with the UP/DOWN button of the controller.

You can select the cursor size from 1 to 8 (from 1 to 4 when the display magnification of the native scan



is [×2] (page 42)).

The larger the number, the smaller the cursor.

#### 4 Adjust the position of the cursor.

**To move leftward or rightward:** Turn the PHASE knob.

**To move upward or downward:** Turn the CHROMA knob.

#### 5 Press the ENTER (Ent) button.

The part inside the cursor is magnified.

You can move the position of the magnified picture with the PHASE knob or CHROMA knob. You can change the magnification ratio with the UP/DOWN button.

You can also change the boundary line color. Press the MENU button of the controller to return to the cursor display.

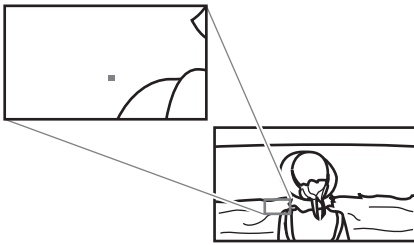

#### To end the pixel zoom operation

When the cursor is displayed or the picture is magnified, press the PIXEL ZOOM button of the controller.

### [Gamut Error Display]

Sets the gamut error display.

A zebra pattern is superimposed on the portion where an error is detected.

#### Notes

- The gamut error display function is effective when the input signal is 3G/HD/SD SDI, HDMI (and the quantization range for the signal is [Limit]). It is effective regardless of the signal format when [Gamma] is set to [S-LOG2(SDR)] or [S-LOG3(SDR)] in the [Color Profile] menu.
- The gamut error display function does not work in the following cases:
  - When the input signal has no sync signal
  - When the internal signal is displayed
  - When [H Delay]/[V Delay] is set to [On]
  - When [Side by Side], [Wipe], [Butterfly], or [Blending] is set to [On]
- In under scan mode, each line of the upper and lower lines of the video signal is also detected for gamut error display.

- The time code display, the closed caption display, and the embedded audio level display are also detected for gamut error display.
- In over scan mode, 5% mask portion is also detected for gamut error display. However, the zebra pattern is not displayed on 5% mask portion.

### [Gamut Error Display]

Sets whether or not to display the gamut error ([Off] or [On]).

### [OSD Notification]

Sets whether or not to display the message of an error notification on the screen when the error is detected ([Off] or [On]).

### [OSD Notification Reset]

Sets the method to reset the error detection mode.

- **[Auto]:** Resets automatically after detecting the error.
- **[Manual]:** Resets manually.

To reset the error detection, select [Error Notify Clear] (page 55) in the [Function Switch] menu of the [Function Setting] menu or set [Error Notify Clear] to on by pressing the Error Notify Clear button <sup>1)</sup> of the controller.

- 1) [Error Notify Clear] is assigned to a function button of the controller in the [Function Key] menu (page 67) of the [Controller] menu.

### [Input Detection]

Sets the error detection of the input signal.

Submenu	Setting
[Detection]	Sets whether or not to detect the error of the input signal ([Off] or [On]).
[Pixel Threshold]	Sets the pixel number of the gamut error in the frame to notify the gamut error detection. When the pixel number of the error is over the set pixel number, the detection is notified. Set to 00000 to 65535. (Default value: [00000])
[Signal Level]	Sets the upper and lower lines of every signal to detect the gamut error.
[SDI YCbCr 10bit]	[Upper Limit] (upper limit) <ul style="list-style-type: none"><li>• [Y]: 0000 to 1023 (Default value: [0983])</li><li>• [Cb]: 0000 to 1023 (Default value: [1004])</li><li>• [Cr]: 0000 to 1023 (Default value: [1004])</li></ul> [Lower Limit] (lower limit) <ul style="list-style-type: none"><li>• [Y]: 0000 to 1023 (Default value: [0020])</li><li>• [Cb]: 0000 to 1023 (Default value: [0019])</li><li>• [Cr]: 0000 to 1023 (Default value: [0019])</li></ul>

Submenu	Setting
[SDI RGB 10bit]	[Upper Limit] (upper limit) <ul style="list-style-type: none"> <li>• [G]: 0000 to 1023 (Default value: [0983])</li> <li>• [B]: 0000 to 1023 (Default value: [0983])</li> <li>• [R]: 0000 to 1023 (Default value: [0983])</li> </ul> [Lower Limit] (lower limit) <ul style="list-style-type: none"> <li>• [G]: 0000 to 1023 (Default value: [0020])</li> <li>• [B]: 0000 to 1023 (Default value: [0020])</li> <li>• [R]: 0000 to 1023 (Default value: [0020])</li> </ul>
[SDI YCbCr 12bit]	[Upper Limit] (upper limit) <ul style="list-style-type: none"> <li>• [Y]: 0000 to 4095 (Default value: [3935])</li> <li>• [Cb]: 0000 to 4095 (Default value: [4019])</li> <li>• [Cr]: 0000 to 4095 (Default value: [4019])</li> </ul> [Lower Limit] (lower limit) <ul style="list-style-type: none"> <li>• [Y]: 0000 to 4095 (Default value: [0080])</li> <li>• [Cb]: 0000 to 4095 (Default value: [0077])</li> <li>• [Cr]: 0000 to 4095 (Default value: [0077])</li> </ul>
[SDI RGB 12bit]	[Upper Limit] (upper limit) <ul style="list-style-type: none"> <li>• [G]: 0000 to 4095 (Default value: [3935])</li> <li>• [B]: 0000 to 4095 (Default value: [3935])</li> <li>• [R]: 0000 to 4095 (Default value: [3935])</li> </ul> [Lower Limit] (lower limit) <ul style="list-style-type: none"> <li>• [G]: 0000 to 4095 (Default value: [0080])</li> <li>• [B]: 0000 to 4095 (Default value: [0080])</li> <li>• [R]: 0000 to 4095 (Default value: [0080])</li> </ul>
[HDMI YCbCr]	[Upper Limit] (upper limit) <ul style="list-style-type: none"> <li>• [Y]: 0000 to 4095 (Default value: [3935]) (12bit conversion value)</li> <li>• [Cb]: 0000 to 4095 (Default value: [4019]) (12bit conversion value)</li> <li>• [Cr]: 0000 to 4095 (Default value: [4019]) (12bit conversion value)</li> </ul> [Lower Limit] (lower limit) <ul style="list-style-type: none"> <li>• [Y]: 0000 to 4095 (Default value: [0080]) (12bit conversion value)</li> <li>• [Cb]: 0000 to 4095 (Default value: [0077]) (12bit conversion value)</li> <li>• [Cr]: 0000 to 4095 (Default value: [0077]) (12bit conversion value)</li> </ul>

Submenu	Setting
[HDMI RGB]	[Upper Limit] (upper limit) <ul style="list-style-type: none"> <li>• [G]: 0000 to 4095 (Default value: [3935]) (12bit conversion value)</li> <li>• [B]: 0000 to 4095 (Default value: [3935]) (12bit conversion value)</li> <li>• [R]: 0000 to 4095 (Default value: [3935]) (12bit conversion value)</li> </ul> [Lower Limit] (lower limit) <ul style="list-style-type: none"> <li>• [G]: 0000 to 4095 (Default value: [0080]) (12bit conversion value)</li> <li>• [B]: 0000 to 4095 (Default value: [0080]) (12bit conversion value)</li> <li>• [R]: 0000 to 4095 (Default value: [0080]) (12bit conversion value)</li> </ul>

### [Post-Process Detection]

Sets the error detection setting for the signal after YCbCr is converted to RGB.

Submenu	Setting
[Detection]	Sets whether or not to detect the error of the input signal ([Off] or [On]).
[Pixel Threshold]	Sets the pixel number of the gamut error in the frame to notify the gamut error detection. When the pixel number of the error is over the set pixel number, the detection is notified. Set to 00000 to 65535. (Default value: [00000])
[Signal Level]	Sets the upper and lower lines of the signal level. The signal level to be set is black level 256 and white level 3760 in 12bit conversion value. <ul style="list-style-type: none"> <li>• [Upper Limit] (upper limit): 0000 to 4095 (Default value: [3761])</li> <li>• [Lower Limit] (lower limit): 0000 to 4095 (Default value: [0255])</li> </ul>

### [Zebra Pattern]

Sets the zebra pattern displayed by the gamut error detection.

Submenu	Setting
[Line]	Sets the direction of the pattern. <ul style="list-style-type: none"> <li>• [Diagonal Type1]: Right descending</li> <li>• [Diagonal Type2]: Left descending</li> </ul>
[Modulation]	Sets the amplitude of the pattern display. Set to 1 to 50. (Default value: [16])

### [Capture]

Captures the still picture for the standard of the color evaluation (HD Frame Capture).

#### Note

Use the BKM-16R with software version 1.6 or higher or BKM-17R to use the HD Frame Capture function.

Submenu	Setting
[Load]	Loads the captured picture from the USB memory stick, etc. When the item is selected, you can select the file name to be loaded.
[Rename]	Changes a file name of the captured picture in the USB memory stick, etc. When the item is selected, the file names are displayed. When the file name is selected, you can change the file name (1 to 20 characters). <ul style="list-style-type: none"> <li>• <b>Existing file name:</b> Enter the existing file name.</li> <li>• <b>[New Name]:</b> Enter a new file name.</li> </ul>
<p><b>Note</b></p> <p>“?” must not be used as the first character.</p>	
[Delete]	Deletes the file of the captured picture in the USB memory stick, etc. When the item is selected, the file names in the USB memory stick, etc. are displayed. When the file name is selected, the following message appears. [Delete this file ?] <ul style="list-style-type: none"> <li>• <b>[OK]:</b> To delete the data, press the ENTER (Ent) button.</li> <li>• <b>[Cancel]:</b> To cancel, press the MENU button.</li> </ul>

## Capturing the Picture of the HD Signal (HD Frame Capture)

The frame picture of the 3G/HD-SDI input signal is captured and saved as a picture file in the USB memory stick, etc. This is used to confirm the color tone and picture angle of the current scene and recorded scene, or as the reference picture to adjust the monitor.  
To save the captured frame, we recommend using “Memory Stick PRO (High-Speed)” or “Memory Stick PRO Duo (High-Speed)”.

### Notes

- Use the BKM-16R with software version 1.6 or higher or BKM-17R to use the HD Frame Capture function.
- The file is saved in TIFF. The file size is a maximum of 13 MB.
- The picture file is captured or loaded without deterioration.
- The saved file may not be opened due to the PC application used.
- The HD Frame Capture function is effective only for the 3G/HD-SDI signal.
- The interlace input signal is captured in each frame (first field (F=0) and second field (F=1)).
- The frame is not captured in the following cases:
  - When [Side by Side], [Wipe], [Butterfly], or [Blending] is set to [On]

- When [Pixel Zoom] is set to on
- When the internal signal is displayed
- When the input signal has no sync signal
- When the captured frame is displayed

### To capture

- 1 Connect the USB memory stick, etc. to the controller.

For details on the USB memory stick, see “Inserting/Ejecting the USB memory stick” on page 92. For the memory stick, see the operating instructions of BKM-16R.

- 2 Display the picture and press the CAPTURE button of the controller at the point on the picture to be captured.

The captured still picture appears on the display.

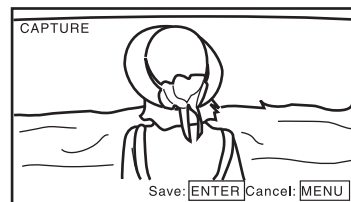

To hide characters on the monitor, set the CHAR OFF button to on. As the characters are hidden, it becomes easy to confirm the still picture. To display the characters, set the CHAR OFF button to off.

- 3 Press the ENTER (Ent) button.

The display of the captured still picture is cleared and saving in the USB memory stick, etc. of the captured frame starts.

The “In progress ■” is displayed and “■” flashes during data saving. (It may take some time to write the data.)

The file of the captured frame is automatically named and the file name is displayed on the screen during file saving.

### Note

The monitor is not operated until the saving is completed.

### To load the captured frame

Press the CAPTURE LOAD button of the controller or select [Load] in the [Capture] menu (page 50) of the [Function Setting] menu, and then select the file name. To cancel the captured frame display, select any one of channel numbers 1 to 30.

## [Internal Signal]

Selects the internal signal display.

You can select from [PLUGE], [Gray] (20% gray signal), [White] (100% white signal), [5 Step] (5 step gray scale signal), [Ramp], [Color Bars], or [Black] (0% black signal).

To cancel the internal signal, select one from the channel numbers 1 to 30 with the numeric buttons of the controller.

### Note

[Internal Signal] is not set in the following cases:

- When the XYZ signal, or the HDMI computer signal is input
- When [Side by Side], [Wipe], [Butterfly], or [Blending] is set to [On]

## [Function Switch]

Sets the function to be assigned to the function button of the controller in the menu.

Submenu	Setting
[Scan Mode]	<p>Sets the scan mode of the picture.</p> <ul style="list-style-type: none"> <li>• <b>[Normal Scan]:</b> Normal Scan</li> <li>• <b>[Under Scan]:</b> 3% under scan</li> <li>• <b>[Over Scan]:</b> Mask of 5% over scan portion in the normal scan</li> </ul>

**Note**

The scan mode is not selectable in the following cases:

- When [Native Scan] is set to [On]
- When the input signal has no sync signal
- When the internal signal is displayed
- When [Side by Side], [Wipe], [Butterfly], or [Blending] is set to [On]

Submenu	Setting
[Native Scan]	<p>Sets whether or not to display the native scan ([Off] or [On]).</p>
	<div data-bbox="1082 251 1171 280" style="background-color: black; color: white; padding: 2px;"><b>Note</b></div> <p>The native scan is not selectable in the following cases:</p> <ul style="list-style-type: none"> <li>• When the input signal has no sync signal</li> <li>• When [Side by Side] is set to [On]</li> <li>• When [Pixel Zoom] is set to on</li> <li>• When the HDMI computer signal is input (The native scan is displayed regardless of the setting.)</li> <li>• When a digital cinema signal (2048 × 1080) is input and the internal signal is displayed ([Native Scan] is set to [Off] and the normal scan is displayed regardless of the setting.)</li> <li>• When the signal system is the SD signal of 720 × 576, [Native Scan Mode] is set to [Aspect Correction] or [×2] and the internal signal is displayed ([Native Scan] is set to [Off] and the normal scan is displayed regardless of the setting.)</li> </ul>
[16:9]	<p>Sets whether or not to display the aspect in 16:9 or 1.896:1 (digital cinema signal) ([Off] or [On]).</p>
	<div data-bbox="1082 987 1171 1017" style="background-color: black; color: white; padding: 2px;"><b>Notes</b></div> <ul style="list-style-type: none"> <li>• The aspect ratio is not selectable in the following cases: <ul style="list-style-type: none"> <li>– When [Native Scan Mode] is set to [×1] or [×2] and [Native Scan] is set to [On]</li> <li>– When the input signal has no sync signal</li> </ul> </li> <li>• The aspect ratio may be fixed to 16:9 due to the signal format.</li> </ul> <p><i>For details, see “Available Signal Formats” on page 80.</i></p>
[H Delay]	<p>Sets whether or not to display in H delay ([Off] or [On]).</p> <p>When the 720/24, 25, 30P signal is input, the display position is changed with the PHASE knob.</p>
	<div data-bbox="1082 1523 1171 1553" style="background-color: black; color: white; padding: 2px;"><b>Note</b></div> <p>The picture is not displayed in H delay in the following cases:</p> <ul style="list-style-type: none"> <li>• When the input signal has no sync signal</li> <li>• When the internal signal is displayed</li> <li>• When [Format] of the [Channel Configuration] menu is set to [HDMI] or [Composite]</li> <li>• When [Side by Side], [Wipe], [Butterfly], or [Blending] is set to [On]</li> <li>• When the captured frame is displayed</li> </ul>

Submenu	Setting
[V Delay]	Sets whether or not to display in V delay ([Off] or [On]).
	<p><b>Note</b></p> <p>The picture is not displayed in V delay in the following cases:</p> <ul style="list-style-type: none"> <li>• When the input signal has no sync signal</li> <li>• When the internal signal is displayed</li> <li>• When [Format] of the [Channel Configuration] menu is set to [HDMI] or [Composite]</li> <li>• When [Side by Side], [Wipe], [Butterfly], or [Blending] is set to [On]</li> <li>• When the captured frame is displayed</li> </ul>
[Flicker Free]	<p>Sets whether or not to perform flicker free ([Off] or [On]).</p> <p>An OLED panel can provide superior video responsiveness and scan driving, reproducing images with little contouring or afterimaging. However, scan driving can cause flicker when input signals have a low vertical frequency (24P/PsF, 50i, etc.). Set [Flicker Free] to [On] to greatly reduce this phenomenon.</p> <p>With this mode set to on, quick-moving images may exhibit contours or an afterimage.</p>
[Aperture]	<p>Sets whether or not to perform aperture modification ([Off] or [On]). (Default value: [Off] (when the signal is displayed in [Aspect Correction] mode of the native display)) (Default value: [On] (when the signal is displayed in mode other than [Aspect Correction] of the native display))</p> <p><b>Note</b></p> <p>When the HDMI computer signal is input, the aperture modification does not function.</p>
[Mono]	Sets whether or not to display in monochrome mode ([Off] or [On]).
[Blue Only]	Sets whether or not to display only the blue signal as a monochrome picture after cutting the red and green signals ([Off] or [On]).
[R Off]	Sets whether or not to cut the red signal ([Off] or [On]).
[G Off]	Sets whether or not to cut the green signal ([Off] or [On]).
[B Off]	Sets whether or not to cut the blue signal ([Off] or [On]).

Submenu	Setting
[Chroma Up]	Sets whether or not to increase the chroma value by 12 dB ([Off] or [On]).
	<p><b>Note</b></p> <p>The chroma value is not increased in the following cases:</p> <ul style="list-style-type: none"> <li>• When the signal to be displayed is RGB or XYZ</li> <li>• When the composite signal is automatically displayed in monochrome depending on the color discrimination</li> <li>• When the internal signal is displayed</li> </ul>
[Interlace]	Sets whether or not to display in interlace mode ([Off] or [On]).
	<p><b>Notes</b></p> <ul style="list-style-type: none"> <li>• Set [Native Scan] to [On] for the interlace display.</li> <li>• The picture is not displayed in interlace mode in the following cases: <ul style="list-style-type: none"> <li>– When [Side by Side], [Wipe], [Butterfly], or [Blending] is set to [On]</li> <li>– When [Pixel Zoom] is set to on</li> </ul> </li> </ul> <p><i>For details of this menu, see “Selecting Display Mode” on page 56.</i></p>
[Marker]	Sets whether or not to display all markers ([Off] or [On]).
	<p><b>Notes</b></p> <ul style="list-style-type: none"> <li>• The marker is not displayed in the following cases: <ul style="list-style-type: none"> <li>– When the input signal has no sync signal</li> <li>– When the internal signal is displayed</li> <li>– When the HDMI computer signal is input</li> <li>– When [H Delay]/[V Delay] is set to [On]</li> <li>– When [Side by Side], [Wipe], [Butterfly], or [Blending] is set to [On]</li> <li>– When [Pixel Zoom] is set to on</li> </ul> </li> <li>• The marker may be displayed in an incorrect position when [External Sync] is [On].</li> </ul>

Submenu	Setting
[Aspect Marker]	Sets whether or not to display the aspect marker ([Off] or [On]).
	<p><b>Notes</b></p> <ul style="list-style-type: none"> <li>The aspect marker is not displayed in the following cases: <ul style="list-style-type: none"> <li>When the input signal has no sync signal</li> <li>When the internal signal is displayed</li> <li>When the HDMI computer signal is input</li> <li>When [H Delay]/[V Delay] is set to [On]</li> <li>When [Side by Side], [Wipe], [Butterfly], or [Blending] is set to [On]</li> <li>When [Pixel Zoom] is set to on</li> </ul> </li> <li>The aspect marker may be displayed in an incorrect position when [External Sync] is [On].</li> </ul>
[Area Marker 1] [Area Marker 2]	Sets whether or not to display the area marker 1 (area marker 2) ([Off] or [On]).
	<p><b>Notes</b></p> <ul style="list-style-type: none"> <li>The area marker 1 (area marker 2) is not displayed in the following cases: <ul style="list-style-type: none"> <li>When the input signal has no sync signal</li> <li>When the internal signal is displayed</li> <li>When the HDMI computer signal is input</li> <li>When [H Delay]/[V Delay] is set to [On]</li> <li>When [Side by Side], [Wipe], [Butterfly], or [Blending] is set to [On]</li> <li>When [Pixel Zoom] is set to on</li> </ul> </li> <li>The area marker may be displayed in an incorrect position when [External Sync] is [On].</li> </ul>

Submenu	Setting
[Center Marker]	Sets whether or not to display the center marker ([Off] or [On]).
	<p><b>Notes</b></p> <ul style="list-style-type: none"> <li>The center marker is not displayed in the following cases: <ul style="list-style-type: none"> <li>When the input signal has no sync signal</li> <li>When the internal signal is displayed</li> <li>When the HDMI computer signal is input</li> <li>When [H Delay]/[V Delay] is set to [On]</li> <li>When [Side by Side], [Wipe], [Butterfly], or [Blending] is set to [On]</li> <li>When [Pixel Zoom] is set to on</li> </ul> </li> <li>The center marker may be displayed in an incorrect position when [External Sync] is [On].</li> </ul>
[Aspect Marker-Line]	Sets whether or not to display the line of the aspect marker ([Off] or [On]).
	<p><b>Notes</b></p> <ul style="list-style-type: none"> <li>The line of the aspect marker is not displayed in the following cases: <ul style="list-style-type: none"> <li>When the input signal has no sync signal</li> <li>When the internal signal is displayed</li> <li>When the HDMI computer signal is input</li> <li>When [H Delay]/[V Delay] is set to [On]</li> <li>When [Side by Side], [Wipe], [Butterfly], or [Blending] is set to [On]</li> <li>When [Pixel Zoom] is set to on</li> </ul> </li> <li>The line of the aspect marker may be displayed in an incorrect position when [External Sync] is [On].</li> </ul>

Submenu	Setting
[Aspect Blanking-Half]	<p>Sets whether or not to set the Aspect Blanking (the blanking outside the area of the aspect marker) to half blanking ([Off] or [On]).</p> <p><b>Notes</b></p> <ul style="list-style-type: none"> <li>The Aspect Blanking is not set to half blanking in the following cases: <ul style="list-style-type: none"> <li>When the input signal has no sync signal</li> <li>When the internal signal is displayed</li> <li>When the HDMI computer signal is input</li> <li>When [H Delay]/[V Delay] is set to [On]</li> <li>When [Side by Side], [Wipe], [Butterfly], or [Blending] is set to [On]</li> <li>When [Pixel Zoom] is set to on</li> </ul> </li> <li>The Aspect Blanking may be displayed in an incorrect position when [External Sync] is [On].</li> </ul>
[Aspect Blanking-Black]	<p>Sets whether or not to set the blanking level of the Aspect Blanking (the blanking outside the area of the aspect marker) to 0% black level ([Off] or [On]).</p> <p><b>Notes</b></p> <ul style="list-style-type: none"> <li>The Aspect Blanking is not set to 0% black level in the following cases: <ul style="list-style-type: none"> <li>When the input signal has no sync signal</li> <li>When the internal signal is displayed</li> <li>When the HDMI computer signal is input</li> <li>When [H Delay]/[V Delay] is set to [On]</li> <li>When [Side by Side], [Wipe], [Butterfly], or [Blending] is set to [On]</li> <li>When [Pixel Zoom] is set to on</li> </ul> </li> <li>The Aspect Blanking may be displayed in an incorrect position when [External Sync] is [On].</li> </ul>
[Side by Side]	<p>Sets whether or not to display in the side by side display ([Off] or [On]).</p> <p><b>Note</b></p> <p>The side by side display is not set in the following cases:</p> <ul style="list-style-type: none"> <li>When the internal signal is displayed</li> <li>When [Pixel Zoom] is set to on</li> </ul>

Submenu	Setting
[Wipe]	<p>Sets whether or not to display in the wipe display ([Off] or [On]).</p> <p><b>Note</b></p> <p>The wipe display is not set in the following cases:</p> <ul style="list-style-type: none"> <li>When the internal signal is displayed</li> <li>When [Pixel Zoom] is set to on</li> </ul>
[Butterfly]	<p>Sets whether or not to display in the butterfly display ([Off] or [On]).</p> <p><b>Note</b></p> <p>The butterfly display is not set in the following cases:</p> <ul style="list-style-type: none"> <li>When the internal signal is displayed</li> <li>When [Pixel Zoom] is set to on</li> </ul>
[Blending]	<p>Sets whether or not to display in the blending display ([Off] or [On]).</p> <p><b>Note</b></p> <p>The blending display is not set in the following cases:</p> <ul style="list-style-type: none"> <li>When the internal signal is displayed</li> <li>When [Pixel Zoom] is set to on</li> </ul>
[Error Notify Clear]	<p>When the item is selected, the notification of the gamut error detection ([OSD Notification]) is cleared.</p> <p><b>Note</b></p> <p>The [Error Notify Clear] is not selected in the following cases:</p> <ul style="list-style-type: none"> <li>When [Gamut Error Display] is set to [Off] in the [Gamut Error Display] menu of the [Function Setting] menu.</li> <li>When [OSD Notification Reset] is set to [Auto] in the [Gamut Error Display] menu of the [Function Setting] menu.</li> </ul>
[Audio Level Meter]	<p>Sets whether or not to display the audio level meter ([Off] or [On]).</p> <p><b>Note</b></p> <p>When [Format] of the [Channel Configuration] menu is set to [Composite] or [HDMI], the audio level meter cannot be displayed.</p>

Submenu	Setting
[ALM Hold Reset]	When the item is selected, the peak hold of the audio level meter is canceled.
<b>Note</b>	
<p>The [ALM Hold Reset] is not selected in the following cases:</p> <ul style="list-style-type: none"> <li>• When [Format] of the [Channel Configuration] menu is set to [Composite] or [HDMI]</li> <li>• When [Audio Level Meter] is set to [Off]</li> <li>• When [Peak Hold] is set to [Off] or [Auto] in the [Audio Level Meter] menu of the [On Screen Set] menu of the [System Configuration] menu</li> </ul>	
[Time Code]	Sets whether or not to display the time code ([Off] or [On]).

## Selecting Display Mode

This monitor applies high-contrast to the picture and reproduces accurate color by displaying the interlace signal in progressive mode by the I/P conversion or the PsF-progressive signal in progressive mode without the I/P conversion.

You can select interlace display mode according to the input signal or the object to evaluate the picture.

**Interlace display mode:** The picture is displayed in interlace mode without I/P conversion processing. The picture near the original quality of the input signal is monitored.

### Notes

- When a 1080/24<sup>1)</sup> P (PsF) or 1080/25P (PsF) input signal is displayed in progressive mode, the frame rate for display is 48<sup>1)</sup> Hz or 50 Hz to obtain flickerless display.
- When the input signal is 1080/24<sup>1)</sup> PsF or 1080/25PsF and [1080I] is set in the [1080I/PsF] menu of the [Channel Configuration] menu, the frame rate for display is 48<sup>1)</sup> Hz or 50 Hz.
- The luminance is reduced owing to the principle of operation in the interlace display mode. However, on this monitor, the normal luminance is set by increasing the value of gain. For this reason, in the interlace display mode, the range of the contrast adjustment is different from the normal level, and the luminance may be reduced according to the setting of the contrast.
- The picture is not displayed in interlace mode in the following cases:
  - When [Side by Side], [Wipe], [Butterfly], or [Blending] is set to [On]
  - When [Pixel Zoom] is set to on

**1** For selecting the interlace display mode, set [Native Scan] (page 52) to [On] in the [Function Setting] menu or by pressing the NATIVE SCAN button of the controller.

**2** Set [Interlace] to [On] in the [Function Switch] menu (page 52) of the [Function Setting] menu, or pressing the INTERLACE button on the controller.

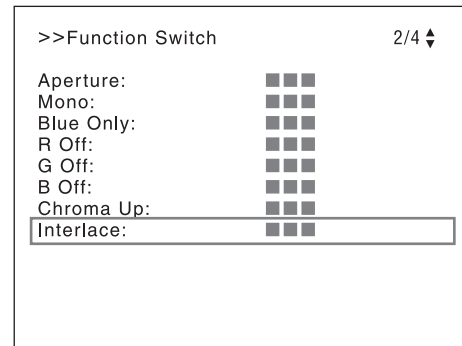

For the input signal to display in frame mode and interlace mode, see “Picture Frame Display” on page 89.

- 1) Also compatible with a frame rate of 1/1.001.

## Selecting the Native Scan/Scan Mode

You can select scan mode from a native scan, under scan (–3%), normal scan (0%), and over scan (mask of 5% over scan portion in the normal scan picture).

You can set scan mode with the NATIVE SCAN button or Scan button of the controller, or in the [Function Switch] menu of the [Function Setting] menu.

### Setting with the NATIVE SCAN button or SCAN button of the controller

#### To set to the native scan mode

Set the NATIVE SCAN button to on. (The LED on the button lights.)

#### To select the scan mode

**1** Set the NATIVE SCAN button to off. (The LED on the button is turned off.)

**2** Press the Scan button<sup>1)</sup> to select the scan mode.

Scan mode is changed to normal, under, and over scan mode by each press of the button.

- 1) Scan function is assigned to a function button of the controller in the [Function Key] menu of the [Controller] menu (page 67).

### Setting in the menu

Set [Scan Mode] or [Native Scan] in the [Function Switch] menu (page 52) of the [Function Setting] menu.



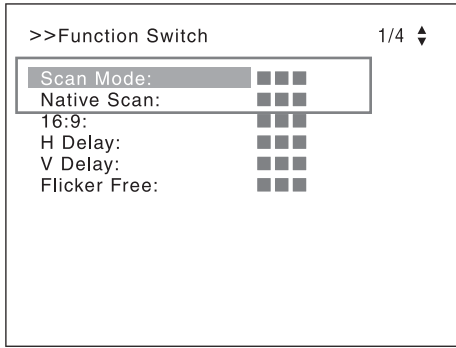

### To set to the native scan mode

Set [Native Scan] to [On].

### To select the scan mode

- 1 Set [Native Scan] to [Off].
- 2 Select [Scan Mode], then select scan mode from the following.

[Normal Scan]: Normal mode

[Under Scan]: Under mode

[Over Scan]: Over mode

#### Note

The scan mode is not selectable in the following cases:

- When [Native Scan] is set to [On]
- When the internal signal is displayed
- When [Side by Side], [Wipe], [Butterfly], or [Blending] is set to [On]

## [System Configuration] Menu

This menu is used to set the system such as the network, parallel remote control function, etc. When [System Configuration] is selected, the following menu is displayed.

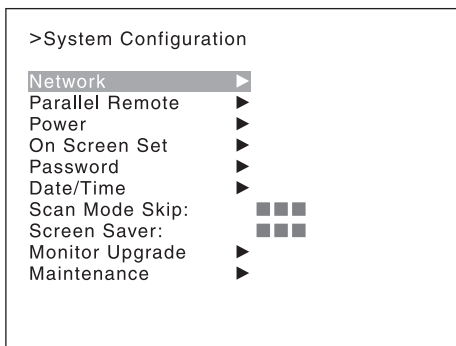

### [Network]

Sets the remote control function of the network.

### [Monitor ID]

Enter a monitor ID number.  
Set to 01 to 99. (Default value: [01])

### [Group ID]

Enter a group ID number.  
Set to 01 to 99. (Default value: [01])

### [Network Setting]

Sets the IP address, subnet mask, and default gateway.  
For the setting value, consult the network administrator.

Submenu	Setting
[IP Address]	Sets the IP address. (Default value: [192.168.000.001])
<b>Note</b>	
	When the NETWORK switch is set to PEER TO PEER, the IP address is set to "192.168.0.1" regardless of the display. When the NETWORK switch is set to LAN, the IP address is set to the displayed one.
[Subnet Mask]	Sets the subnet mask. (Default value: [255.255.255.000])
<b>Note</b>	
	When the NETWORK switch is set to PEER TO PEER, the subnet mask is set to "255.255.255.000" regardless of the display. When the NETWORK switch is set to LAN, the subnet mask is set to the displayed one.
[Default Gateway]	Sets whether or not to set the default gateway ([Off] or [On]).
[Address]	Sets the address of the default gateway. (Default value: [---.---.---.---] (no setting))
[Cancel]	Cancels the changed or confirmed setting.
[Confirm]	Saves the changed or confirmed setting.

### [Protocol Setting]

Sets the required items for communications such as the port number.  
For the setting value, consult the network administrator.

Submenu	Setting
[SDCP/SDAP Community]	Sets the SDCP/SDAP community name. When the item is selected, you can enter the community name (four characters). <ul style="list-style-type: none"> <li>• [SONY]: SONY is entered as a community name.</li> <li>• [New Name]: Enter a new name.</li> </ul>
[SDCP Port No]	Sets the SDCP port number. Set from 53434 to 53534. (Default value: [53484])

Submenu	Setting
[SDAP Port No]	Sets the SDAP port number. Set from 53812 to 53912. (Default value: [53862])
[SDAP Broadcast]	Sets whether or not to issue the SDAP ([Disable] or [Enable]).
[SDAP Broadcast Period]	Sets the period (seconds) to issue the SDAP. Set from 05 to 30. (Default value: [15])
[Acceptable IP Address]	Sets the IP address to connect. When the item is selected, you can set [IP1] to [IP4]. <ul style="list-style-type: none"> <li>• <b>[Cancel]</b>: Cancels the changed or confirmed setting.</li> <li>• <b>[Confirm]</b>: Saves the changed or confirmed setting.</li> </ul>
[Reset Protocol Setting]	Resets the protocol setting. When the item is selected, the following message appears. [Are you sure ?] <ul style="list-style-type: none"> <li>• <b>[OK]</b>: To reset data, press the ENTER (Ent) button.</li> <li>• <b>[Cancel]</b>: To cancel, press the MENU button.</li> </ul>

## [Parallel Remote]

Sets the parallel remote function.

Submenu	Setting
[Parallel Remote]	Selects whether or not to use the parallel remote functions ([Off] or [On]).

Submenu	Setting
[1 Pin] – [8 Pin]	<p>Assigns the function to each pin of the PARALLEL REMOTE connector when [Parallel Remote] is set to [On]. The default assignment of functions is as follows:</p> <ul style="list-style-type: none"> <li>• <b>1 Pin</b>: [CH01]</li> <li>• <b>2 Pin</b>: [CH02]</li> <li>• <b>3 Pin</b>: [Marker]</li> <li>• <b>4 Pin</b>: [Mono]</li> <li>• <b>6 Pin</b>: unused</li> <li>• <b>7 Pin</b>: unused</li> <li>• <b>8 Pin</b>: [Tally]</li> </ul> <p>You can change the assignment to the following functions for pins 1 to 4 and 6 to 8. The functions shown with item name only are the same as those assigned to the function buttons on the controller.</p> <p><i>For details on these functions, see [Function Key] (page 67) of the [Controller] menu.</i></p> <p>[Parallel Remote] (1/4)</p> <ul style="list-style-type: none"> <li>• <b>[CH01] to [CH30]</b>: Selects a channel number. Enter the desired channel number with the numeric buttons.</li> <li>• <b>[---</b>: Unused</li> <li>• <b>[Under Scan]</b> <sup>1)</sup>, <b>[Over Scan]</b> <sup>1)</sup>, <b>[Native Scan]</b>, <b>[16:9]</b>, <b>[H Delay]</b>, <b>[V Delay]</b>, <b>[Flicker Free]</b></li> </ul> <p>1) The scan mode is set to [Normal Scan] when [Under Scan] or [Over Scan] is off.</p> <p>[Parallel Remote] (2/4)</p> <ul style="list-style-type: none"> <li>• <b>[Aperture]</b>, <b>[Mono]</b>, <b>[Blue Only]</b>, <b>[R Off]</b>, <b>[G Off]</b>, <b>[B Off]</b>, <b>[Chroma Up]</b>, <b>[Interlace]</b></li> <li>• <b>[Tally]</b>: The function to turn on the tally lamp</li> <li>• <b>[Sleep]</b>: The monitor power function</li> </ul> <p>[Parallel Remote] (3/4)</p> <ul style="list-style-type: none"> <li>• <b>[Marker]</b>, <b>[Aspect Marker]</b>, <b>[Area Marker 1]</b>, <b>[Area Marker 2]</b>, <b>[Center Marker]</b>, <b>[Aspect Marker-Line]</b>, <b>[Aspect Blanking-Half]</b>, <b>[Aspect Blanking-Black]</b></li> </ul> <p>[Parallel Remote] (4/4)</p> <ul style="list-style-type: none"> <li>• <b>[Side by Side]</b>, <b>[Wipe]</b>, <b>[Butterfly]</b>, <b>[Blending]</b>, <b>[Error Notify Clear]</b>, <b>[Audio Level Meter]</b>, <b>[ALM Hold Reset]</b>, <b>[Time Code]</b></li> </ul> <p><i>For the pin assignment, see “PARALLEL REMOTE connector” in “Location and Function of Parts and Controls” on page 14.</i></p>

## [Power]

Sets the status of the monitor when the main power is turned on or the power is turned on by remote operation.

Submenu	Setting
[Sleep Mode]	Sets the status when the main power switch is turned on. <ul style="list-style-type: none"> <li>• [Off]: Operation mode</li> <li>• [On]: Sleep mode</li> </ul>
[Power On Status]	Sets the input channel when the power is turned on. <ul style="list-style-type: none"> <li>• [Last]: Sets to the channel that was selected at the time the power was last turned off.</li> <li>• [CH]: Sets to the channel number specified in Default CH.</li> </ul>
[Default CH]	Selects the channel (01 to 30) when the [Power On Status] is set to [CH]. (Default value: [01])

## [On Screen Set]

Sets the items for the screen display.

## [Input Information]

Sets the display of the input information.

Submenu	Setting
[Format]	Sets the display mode of the signal system. <ul style="list-style-type: none"> <li>• [Auto]: Disappears after being displayed for a while.</li> <li>• [Off]: Not displayed.</li> </ul>
<div style="background-color: black; color: white; padding: 2px; text-align: center;"><b>Note</b></div> <p>The picture rate display is [23.98], [29.97], or [59.94] (example 1080/59.94P) when the signal is input from the SDI input, [Format] is set to [3G/HD/SD-SDI Auto] (page 38) in the [Channel Configuration] menu, and the Picture Rate information for the Payload ID is 23.98, 29.97, or 59.94, even if the monitor determines the picture rate as 24Hz, 30Hz, or 60Hz.</p> <p><i>For details on Payload ID, see [SDI Payload ID Status] (page 65) of the [System Status] menu or "Displaying the Monitor Status Page" (page 70).</i></p>	
[Position]	Sets the display position for the signal system. <ul style="list-style-type: none"> <li>• [Top Left]: top left</li> <li>• [Top Center]: top center</li> <li>• [Top Right]: top right</li> <li>• [Bottom Left]: bottom left</li> <li>• [Bottom Center]: bottom center</li> <li>• [Bottom Right]: bottom right</li> </ul>
[CH No]	Sets the display mode of the channel number. <ul style="list-style-type: none"> <li>• [Auto]: Disappears after being displayed for a while.</li> <li>• [Off]: Not displayed.</li> </ul>

Submenu	Setting
[Position]	Sets the display position for the channel number. <ul style="list-style-type: none"> <li>• [Top Left]: top left</li> <li>• [Top Center]: top center</li> <li>• [Top Right]: top right</li> <li>• [Bottom Left]: bottom left</li> <li>• [Bottom Center]: bottom center</li> <li>• [Bottom Right]: bottom right</li> </ul>
[CH Name]	Sets the display mode of the channel name. <ul style="list-style-type: none"> <li>• [Auto]: Disappears after being displayed for a while.</li> <li>• [Off]: Not displayed.</li> </ul>
[Position]	Sets the display position for the channel name. <ul style="list-style-type: none"> <li>• [Top Left]: top left</li> <li>• [Top Center]: top center</li> <li>• [Top Right]: top right</li> <li>• [Bottom Left]: bottom left</li> <li>• [Bottom Center]: bottom center</li> <li>• [Bottom Right]: bottom right</li> </ul>
[Scan Mode]	Sets the display mode of the scan mode. <ul style="list-style-type: none"> <li>• [Auto]: Disappears after being displayed for a while.</li> <li>• [Off]: Not displayed.</li> </ul>
[Position]	Sets the display position for the scan mode. <ul style="list-style-type: none"> <li>• [Top Left]: top left</li> <li>• [Top Center]: top center</li> <li>• [Top Right]: top right</li> <li>• [Bottom Left]: bottom left</li> <li>• [Bottom Center]: bottom center</li> <li>• [Bottom Right]: bottom right</li> </ul>

## [Closed Caption]

Sets the items for the closed caption display.

### Note

When [Format] of the [Channel Configuration] menu is set to [Composite] or [HDMI], the closed caption cannot be displayed.

Submenu	Setting
[Closed Caption]	Sets whether or not to display closed caption signal ([Off] or [On]).

Submenu	Setting
[Type]	Sets the closed caption type. <ul style="list-style-type: none"> <li>• <b>[Auto1]:</b> Select to set to 608(VBI) when the SD-SDI signal is input or 708 when the HD-SDI signal is input.</li> <li>• <b>[Auto2]:</b> Select to set to 608(VBI) when the SD-SDI signal is input or 608(708) when the HD-SDI signal is input.</li> <li>• <b>[708]:</b> Select to display the closed caption signal of the EIA/CEA-708 standards.</li> <li>• <b>[608(708)]:</b> Select to display the closed caption signal of the EIA/CEA-608 standards transmitted by EIA/CEA-708 standards.</li> <li>• <b>[608(VBI)]:</b> Select to display the closed caption signal of the EIA/CEA-608 standards transmitted by using the line 21.</li> </ul>
[Service 708]	Sets Service when [Type] is set to [708]. You can select from [Service1] to [Service6]. (Default value: [Service1])
[Service 608]	Sets Service when [Type] is set to [608(VBI)] or [608(708)]. You can select from [CC1] to [CC4] or [Text1] to [Text4]. (Default value: [CC1])
[OSD Level]	Sets the luminance of the letter. You can select from [High] (bright) or [Low] (dark).

### [Audio Level Meter]

Sets the audio level meter.

#### Notes

- When [Format] of the [Channel Configuration] menu is set to [Composite] or [HDMI], the audio level meter cannot be displayed.
- The items selectable with [Audio CH] are different depending on the input signal.

Submenu	Setting
[Audio CH]	Sets the audio channel. <b>When the Dual Link and 3G-B signal is input</b> Select [CH1-CH8] or [CH9-CH16]. <b>When another signal is input</b> [CH1-CH8] and [CH9-CH16] is set.
[Position]	Sets the display position of the audio level meter. Select [Bottom] (lower) or [Top] (upper).
[Transparency]	Sets the background transparency of the audio level meter. <ul style="list-style-type: none"> <li>• <b>[Black]:</b> The background becomes black.</li> <li>• <b>[Half]:</b> The background becomes translucent.</li> </ul>

Submenu	Setting
[Peak Hold]	Sets the peak hold mode of the audio level meter. <ul style="list-style-type: none"> <li>• <b>[Off]:</b> The peak hold does not function.</li> <li>• <b>[Auto]:</b> The peak hold is automatically released after about 1 second.</li> <li>• <b>[Manual Reset]:</b> The peak hold is released manually. To release the peak hold, select [ALM Hold Reset] (page 56) in the [Function Switch] menu of the [Function Setting] menu or set [ALM Hold Reset] to on by pressing the ALM Hold Reset button<sup>1)</sup> of the controller.</li> </ul> <p>1) [ALM Hold Reset] is assigned to the controller in the [Function Key] menu (page 67) of the [Controller] menu.</p>

### Displaying the Audio Level Meter

#### Note

As the audio level meter is superimposed on the video signal, the audio level meter may be invisible partially because of the scan mode setting of the monitor.

- 1 Input the SDI signal.
- 2 Select the channel.
- 3 Set the audio level meter in the [Audio Level Meter] menu (page 60) of the [On Screen Set] menu in the [System Configuration] menu.
- 4 Set [Audio Level Meter] (page 55) to [On] in the [Function Switch] menu of the [Function Setting] menu or by pressing the ALM button of the controller.

The audio level meter is displayed.

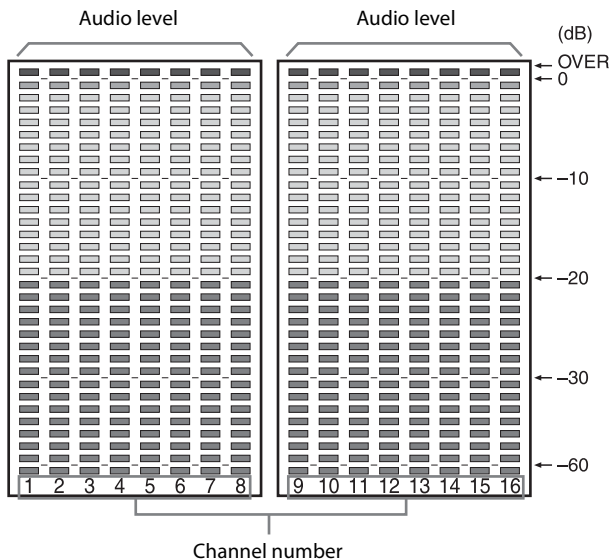

### To cancel the display of the audio level meter

Set [Audio Level Meter] (page 55) to [Off] in the [Function Switch] menu of the [Function Setting] menu or by pressing the ALM button of the controller.

#### Note

Use the BKM-16R with software version 1.4 or higher or BKM-17R to assign [Audio Level Meter] or [ALM Hold Reset] function to a function button of the controller.

### [Time Code]

Sets the time code.

The setting is effective when the SDI signal is input.

Submenu	Setting
[VITC/LTC]	Sets the type of the time code. <ul style="list-style-type: none"> <li>[VITC]</li> <li>[LTC]</li> </ul>
[Position]	Sets the display position of the time code. <ul style="list-style-type: none"> <li>[Top Left]: top left</li> <li>[Top Center]: top center</li> <li>[Top Right]: top right</li> <li>[Bottom Left]: bottom left</li> <li>[Bottom Center]: bottom center</li> <li>[Bottom Right]: bottom right</li> </ul>
[Level]	Sets the luminance of the time code. <ul style="list-style-type: none"> <li>[High]: Displays brightly.</li> <li>[Low]: Displays with the brightness limited.</li> </ul>

### Displaying the Time Code

The time code superimposed on the SDI signals is displayed.

#### Note

As the time code is superimposed on the video signal, the time code may be invisible partially because of the scan mode setting of the monitor.

- 1 Input the SDI signal.
- 2 Select the channel.
- 3 Set the time code in the [Time Code] menu (page 61) of the [On Screen Set] menu in the [System Configuration] menu.
- 4 Set [Time Code] (page 56) to [On] in the [Function Switch] menu of the [Function Setting] menu or by pressing the TIME CODE button of the controller.

The time code is displayed.

### To cancel the time code display

Set [Time Code] (page 56) to [Off] in the [Function Switch] menu of the [Function Setting] menu or by pressing the TIME CODE button of the controller.

#### Note

Use the BKM-16R with software version 1.4 or higher or BKM-17R to assign [Time Code] or [ALM Hold Reset] function to a function button of the controller.

### [Over Range]

When a portion of the signal exceeds the dynamic range of the internal signal processing circuit, it is determined as over range. This menu sets whether or not to display a zebra pattern on the detected over range portion ([Off], [On]).

When over range is detected, adjust the contrast or brightness to a lower level.

#### Notes

- When over range occurs, the OVER RANGE indicator on the front of the unit lights in amber regardless of the setting of this menu.
- When [Gamut Error Display] of the [Function Setting] menu is set to [On], the zebra pattern in the area where the error was detected is also included as a detection target of over range.

### [Password]

Sets the password for the menu.

Enter a four-digit number for the password. (Default value: [9999])

### [Change Password]

Changes the password.

- [Enter New Password]: Enter a new password with the numeric buttons and press the ENTER (Ent) button.
- [Re-Enter Password]: Enter the new password again and press the ENTER (Ent) button. The password is registered.

To change it, press the MENU button.

## [Apply Password]

Sets whether or not to apply the password to each menu ([Yes] or [No]).

Submenu	Setting
[Adjustment]	<ul style="list-style-type: none"><li>• [Yes]: Apply the password.</li><li>• [No]: Do not apply the password.</li></ul>
[Channel Configuration]	<ul style="list-style-type: none"><li>• [Yes]: Apply the password.</li><li>• [No]: Do not apply the password.</li></ul>
[Auxiliary Setting]	<ul style="list-style-type: none"><li>• [Yes]: Apply the password.</li><li>• [No]: Do not apply the password.</li></ul>
[Function Setting]	<ul style="list-style-type: none"><li>• [Yes]: Apply the password.</li><li>• [No]: Do not apply the password.</li></ul>
[System Configuration]	<ul style="list-style-type: none"><li>• [Yes]: Apply the password.</li><li>• [No]: Do not apply the password.</li></ul>
[Individual Item]	Sets whether or not to apply the password to the [System Configuration] menu.
[Network]	<ul style="list-style-type: none"><li>• [Yes]: Apply the password.</li><li>• [No]: Do not apply the password.</li></ul>
[Parallel Remote]	<ul style="list-style-type: none"><li>• [Yes]: Apply the password.</li><li>• [No]: Do not apply the password.</li></ul>
[Power]	<ul style="list-style-type: none"><li>• [Yes]: Apply the password.</li><li>• [No]: Do not apply the password.</li></ul>
[On Screen Set]	<ul style="list-style-type: none"><li>• [Yes]: Apply the password.</li><li>• [No]: Do not apply the password.</li></ul>
[Date/Time]	<ul style="list-style-type: none"><li>• [Yes]: Apply the password.</li><li>• [No]: Do not apply the password.</li></ul>
[Scan Mode Skip]	<ul style="list-style-type: none"><li>• [Yes]: Apply the password.</li><li>• [No]: Do not apply the password.</li></ul>
[Screen Saver]	<ul style="list-style-type: none"><li>• [Yes]: Apply the password.</li><li>• [No]: Do not apply the password.</li></ul>
[File Management]	<ul style="list-style-type: none"><li>• [Yes]: Apply the password.</li><li>• [No]: Do not apply the password.</li></ul>
[Controller]	<ul style="list-style-type: none"><li>• [Yes]: Apply the password.</li><li>• [No]: Do not apply the password.</li></ul>
[Key Protect]	<ul style="list-style-type: none"><li>• [Yes]: Apply the password.</li><li>• [No]: Do not apply the password.</li></ul>

## [Date/Time]

When the item is selected, you can set or change the date and time.

Submenu	Setting
[Year]	Sets the year.
[Month]	Sets the month.
[Day]	Sets the day.
[Hour]	Sets the hour (in 24-hour display).
[Minute]	Sets the minute.
[Cancel]	Cancels the setting.
[Confirm]	Executes the setting. Second is set to 0.

## [Scan Mode Skip]

Sets the scan mode to be skipped when the Scan button is pressed in the single mode connection.

- [None]: No scan is skipped.
- [Under Scan]: The under scan is skipped.
- [Over Scan]: The over scan is skipped.

## [Screen Saver]

Sets the screen saver function.

- [On]: When a still image is displayed on the screen for 10 minutes or more, the brightness of the screen is automatically reduced to prevent burn-in of the screen. The brightness returns to normal if you input a moving image or operate the controller. Approximately one minute before the screen saver is activated, the STATUS indicator starts flashing rapidly. Then the flashing slows in green when the screen saver is activated.
- [Off]: Disables the screen saver function.

### Note

The screen saver function is automatically set to [On] during manual adjustment of the color temperature, contrast, brightness, chroma, and phase, regardless of the setting of this item.

## [Monitor Upgrade]

Upgrades the monitor.

When the item is selected, the screen for inputting the password is displayed.

After the 4-digit password is entered, the current versions of [Software Version], [Kernel Version], [FPGA Version] are displayed.

*For the password, see [Password] (page 61) of the [System Configuration] menu.*

*For details on upgrading the monitor, see “Upgrading the Monitor and Controller” on page 72.*

Submenu	Setting
[Software Upgrade]	Upgrades the software for the monitor.
[Kernel Upgrade]	Upgrades the kernel of the monitor.
[FPGA Upgrade]	Upgrades the FPGA data of the monitor.

## [Maintenance]

The menu for the Sony service representative is displayed.

## [File Management] Menu

The system data is saved, copied, and deleted.

When [File Management] is selected, the following menu is displayed.

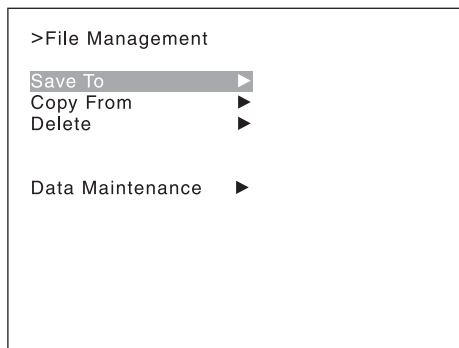

**Note**

Use the BKM-16R with software version 1.6 or higher or BKM-17R to use the File Management function.

**[Save To]**

Saves the data in the USB memory stick, etc.

**Note**

Use the USB memory stick, etc. after formatting.

Submenu	Setting
[External Memory]	<p>Saves the data in the USB memory stick, etc.</p> <p>When the item is selected, you can select the file to save data or create a new file name.</p> <ul style="list-style-type: none"> <li>• <b>[New Name]:</b> Enter a new name of the new file (1 to 20 characters).</li> <li>• <b>Existed file name:</b> Select the file to save data.</li> </ul> <p>The following message appears. [Overwrite this file ?]</p> <ul style="list-style-type: none"> <li>• <b>[OK]:</b> To overwrite the data, press the ENTER (Ent) button.</li> <li>• <b>[Cancel]:</b> To cancel, press the MENU button.</li> </ul>

**Note**

When a new name is entered, the “.” must not be used as the first character.

**Copying the Setting or Adjustment Value to Another Monitor**

You can save the setting or adjustment value in the USB memory stick, etc. and copy it to another monitor.

**1** Connect the USB memory stick, etc. to the controller.

*For details on the USB memory stick, see “Inserting/Ejecting the USB memory stick” on page 92.*

*For the memory stick, see the operating instructions of BKM-16R.*

**2** Select [External Memory] in the [Save To] menu (page 63) of the [File Management] menu, and then select [New Name] or the existing file name.

When you select [New Name], the display to create a new name appears.

**Display example**

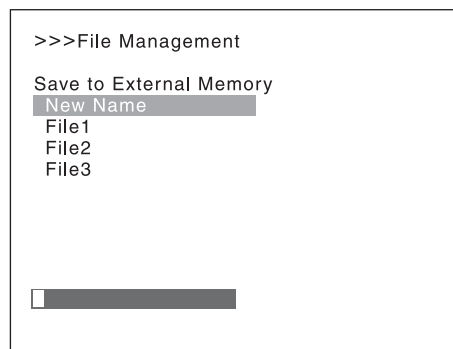

Enter a new name (1 to 20 characters).  
When the existing file name is selected, the display to confirm a file name appears.

**Display example**

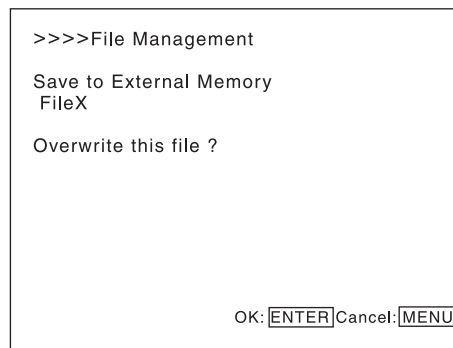

**3** Press the ENTER (Ent) button.

The data is saved in the USB memory stick, etc.

**Notes**

- Use the BKM-16R with software version 1.6 or higher or BKM-17R for data saving, copying and deleting using the USB memory stick, etc.
- Use the USB memory stick, etc. with data stored by the BVM-E251/BVM-E171 to use the [External Memory] function.

**[Copy From]**

Copies the data.

Submenu	Setting
[Other Monitor]	Selects the data of other monitor.
	<p><b>Note</b></p> <p>Use the BVM-E251/BVM-E171 as a source monitor to use the [Other Monitor] function.</p>
[Monitor ID]	<p>Enter the ID number of the source monitor.</p> <p>When the NETWORK switch is set to PEER TO PEER, this is not selectable.</p> <p>When the ID number is entered, you can select the data to be copied.</p> <ul style="list-style-type: none"> <li>• <b>[All]</b>: Copies all data.</li> <li>• <b>[Picture Preset]</b>: Copies the picture preset data.</li> <li>• <b>[Color Temp]</b>: Copies the color temperature data.</li> <li>• <b>[CH Memory]</b>: Copies the channel memory data.</li> <li>• <b>[Marker]</b>: Copies the preset data of the marker.</li> <li>• <b>[System]</b>: Copies the system data.</li> </ul>
[External Memory]	Selects the data in the source USB memory stick, etc.
	<p><b>Note</b></p> <p>Use the USB memory stick, etc. with data stored by the BVM-E251/BVM-E171 to use the [External Memory] function.</p> <p>When the item is selected, the file names in the USB memory stick, etc. are displayed.</p> <p>When the item is selected, you can select the data to be copied.</p> <ul style="list-style-type: none"> <li>• <b>[All]</b>: Copies all data.</li> <li>• <b>[Picture Preset]</b>: Copies the picture preset data.</li> <li>• <b>[Color Temp]</b>: Copies the color temperature data.</li> <li>• <b>[CH Memory]</b>: Copies the channel memory data.</li> <li>• <b>[Marker]</b>: Copies the preset data of the marker.</li> <li>• <b>[System]</b>: Copies the system data.</li> </ul>

## [Delete]

Deletes the file in the USB memory stick, etc.

Submenu	Setting
[External Memory]	<p>Deletes the file in the USB memory stick, etc.</p> <p>When the item is selected, the file names in the USB memory stick, etc. are displayed.</p> <p>When the file is selected, the following message appears.</p> <p>[Delete this file ?]</p> <ul style="list-style-type: none"> <li>• <b>[OK]</b>: To delete the data, press the ENTER (Ent) button.</li> <li>• <b>[Cancel]</b>: To cancel, press the MENU button.</li> </ul>

## [Data Maintenance]

Performs maintenance of the system data.

Submenu	Setting
[Back Up System Data]	<p>Writes the data to the USB memory stick, etc. as the backup data.</p> <p>The “In progress ■” is displayed and “■” flashes during data writing. (It may take some time to write the data.)</p>
[Restore System Data]	<p>Reads the data from the USB memory stick, etc.</p> <p><b>Note</b></p> <p>Use the USB memory stick, etc. written by the BVM-E251/BVM-E171 to use the [Restore System Data] function.</p> <ul style="list-style-type: none"> <li>• <b>[OK]</b>: To continue, press the ENTER (Ent) button. Reads the data from the USB memory stick, etc. and automatically restarts the monitor.</li> <li>• <b>[Cancel]</b>: To cancel, press the MENU button. Returns to the [Data Maintenance] menu.</li> </ul>

## [System Status] Menu

This menu is used to view general data about the monitor status, current channel, etc.

When [System Status] is selected, the following menus are displayed.

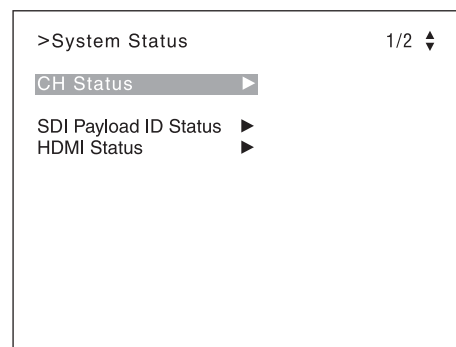



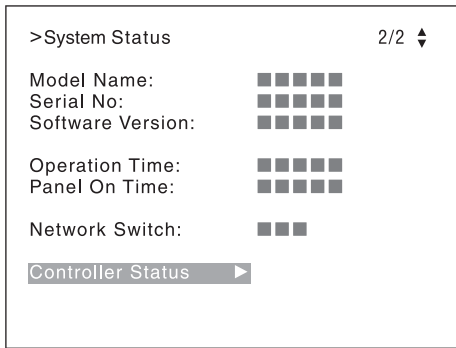

Submenu	Setting
[CH Status]	<p>Displays the information on the used channels.</p> <p>The information of the internal signal assigned to the channel number is displayed on the channels 91 to 97.</p> <ul style="list-style-type: none"> <li>• <b>[CH]</b>: Channel number</li> <li>• <b>[Inp]</b>: Input connector number</li> <li>• <b>[Format]</b>: Input signal format</li> <li>• <b>[Name]</b>: Channel name</li> </ul> <p><i>For details on the assigned signal, see "Channel numbers 91 to 97 assignment" on page 27.</i></p>

Submenu	Setting
[SDI Payload ID Status]	<p>Displays the information of the Payload ID data superimposed on the SDI signal and current signal status of the monitor. When [Format] of the [Channel Configuration] menu is set to a setting other than [Composite] or [HDMI], the following is displayed.</p> <ul style="list-style-type: none"> <li>• <b>InputX</b>: Input connector [Input1], [Input2], or [Input1&amp;2] of the displayed information is displayed.</li> <li>• <b>[Payload ID]</b>: XX XX XX XX (4-byte data for Payload ID of the SMPTE-352M standard) Displays the 4-byte data in hexadecimal in sequence of Byte 1, Byte 2, Byte 3, and Byte 4. When the Payload ID information is not set, only [Current Status] is displayed and [---] is displayed for other items. When the following information is not decoded, [Unknown] is displayed.</li> <li>• <b>[Video Standard]</b>: Decode display of Byte 1_Bit 6-0 (SD-SDI/HD-SDI/3G-SDI/Dual Link HD-SDI, etc.)</li> <li>• <b>[Sampling Structure]</b>: Decode display of Byte 3_Bit 3-0 (4:2:2 Y/Cb/Cr / 4:4:4 Y/Cb/Cr / 4:4:4 G/B/R, etc.)</li> <li>• <b>[Bit Depth]</b>: Decode display of Byte 4_Bit 1-0 (8bit/10bit/12bit)</li> <li>• <b>[Picture Rate]</b>: Decode display of Byte 2_Bit 3-0 (23.98/24/25/29.97/30/50/59.94/60)</li> <li>• <b>[Scanning Method]</b>: Decode display of Byte 2_Bit 7/decode display of Byte 2_Bit 6 (Interlace/Progressive, Progressive/Progressive, etc.)</li> <li>• <b>[Link Number]</b>: Decode display of Byte 4_Bit 7-6 (Single/Link_1 / Link_2 / Link_3 / Link_4)</li> <li>• <b>[Current Status]</b>: Current status of the monitor</li> <li>• <b>[Format]</b>: Displayed as "[Video Standard] + [Sampling Structure] + [Bit Depth]" [Video Standard]: 3G/DL/HD/SD [Sampling Structure]: 422 YCbCr/444 YCbCr/444 RGB/444 XYZ [Bit Depth]: 10/12</li> <li>• <b>[I/PsF/P]</b>: [Interlace] / [PsF] / [Progressive]</li> </ul> <p><i>You can confirm the same information using the STATUS button on the controller. For details, see "Displaying the Monitor Status Page" page 70</i></p>

Submenu	Setting
[HDMI Status]	Displays the signal information of the HDMI signal. <ul style="list-style-type: none"> <li>• <b>[Pixel Encoding]:</b> [RGB 4:4:4] / [YCbCr 4:4:4] / [YCbCr 4:2:2]</li> <li>• <b>[Color Depth]:</b> [8bit] / [10bit] / [12bit]</li> <li>• <b>[Colorimetry]:</b> [ITU-R BT.601] / [ITU-R BT.709] / [ITU-R BT.2020]</li> <li>• <b>[RGB Range]:</b> [Limit] / [Full]</li> </ul>
<div style="background-color: black; color: white; padding: 2px; text-align: center;"><b>Notes</b></div> <ul style="list-style-type: none"> <li>• When the [HDMI Auto] menu is set to [On] in the [Matrix/Color Profile] menu of the [Channel Configuration] menu, the [Matrix] status is displayed.</li> <li>• When the [HDMI Auto] menu is set to [On] in the [RGB Range] menu of the [Channel Configuration] menu, the [RGB Range] status is displayed.</li> </ul> <p><i>You can confirm the same information using the STATUS button on the controller. For details, see "Displaying the Monitor Status Page" (page 70).</i></p>	
[Model Name]	Displays the model name of the monitor.
[Serial No]	Displays the serial number of the monitor.
[Software Version]	Displays software version of the monitor.
[Operation Time]	Displays operation time (hours, in total) of the monitor.
[Panel On Time]	Displays brighten time (hours, in total) of the panel.
[Network Switch]	Displays the NETWORK switch setting.
[Controller Status]	Displays information on the controller. <ul style="list-style-type: none"> <li>• <b>[Model Name]:</b> Displays the model name.</li> <li>• <b>[Serial No]:</b> Displays the serial number.</li> <li>• <b>[Software Version]:</b> Displays software version.</li> <li>• <b>[Network Switch]:</b> Displays the NETWORK switch setting.</li> </ul>

## [Controller] Menu

This menu is for the network setting and assigning the function to the function button of the controller. When [Controller] is selected, the following menu is displayed.

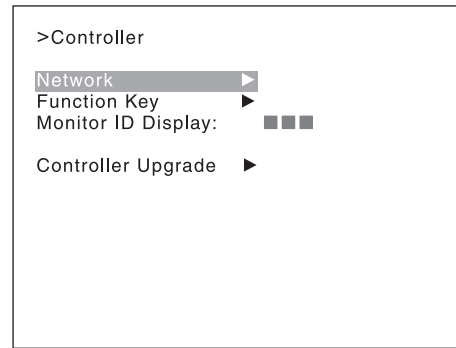

## [Network]

Sets the remote control function of the network. For the setting value, consult the network administrator.

## [Network Setting]

Sets the IP address, subnet mask, and default gateway.

Submenu	Setting
[IP Address]	Sets the IP address. (Default value: [192.168.000.100])
<div style="background-color: black; color: white; padding: 2px; text-align: center;"><b>Note</b></div> <p>When the NETWORK switch is set to PEER TO PEER, the IP address is set to "192.168.0.100" regardless of the display. When the NETWORK switch is set to LAN, the IP address is set to the displayed one.</p>	
[Subnet Mask]	Sets the subnet mask. (Default value: [255.255.255.000])
<div style="background-color: black; color: white; padding: 2px; text-align: center;"><b>Note</b></div> <p>When the NETWORK switch is set to PEER TO PEER, the subnet mask is set to "255:255:255:000" regardless of the display. When the NETWORK switch is set to LAN, the subnet mask is set to the displayed one.</p>	
[Default Gateway]	Sets whether or not to set the default gateway ([Off] or [On]).
[Address]	Sets the address of the default gateway. (Default value: [---.---.---.---] (no setting))
[Cancel]	Cancels the changed or confirmed setting.
[Confirm]	Saves the changed or confirmed setting.

## [Protocol Setting]

Sets the required items for communications such as the port number. For the setting value, consult the network administrator.

Submenu	Setting
[SDCP/SDAP Community]	Sets the SDCP/SDAP community name. When the item is selected, you can enter the community name (four characters). <ul style="list-style-type: none"> <li>[<b>SONY</b>]: SONY is entered as a community name.</li> <li>[<b>New Name</b>]: Enter a new name.</li> </ul>
[SDCP Port No]	Sets the SDCP port number. Set from 53434 to 53534. (Default value: [53484])
[SDAP Port No]	Sets the SDAP port number. Set from 53812 to 53912. (Default value: [53862])
[SDAP Broadcast]	Sets whether or not to issue the SDAP ([Disable] or [Enable]).
[SDAP Broadcast Period]	Sets the period (seconds) to issue the SDAP. Set from 05 to 30. (Default value: [30])
[Reset Protocol Setting]	Resets the protocol setting. When the item is selected, the following message appears. [Are you sure ?] <ul style="list-style-type: none"> <li>[<b>OK</b>]: To reset data, press the ENTER (Ent) button.</li> <li>[<b>Cancel</b>]: To cancel, press the MENU button.</li> </ul>

## [Function Key]

Assigns the function to the function buttons of the controller.

For details on the function assignment, see “Assigning a Function to a Function Button” (page 68).

### Notes

- Use the BKM-16R with software version 1.6 or higher or BKM-17R to assign [Status], [Center Marker], [Aspect Marker-Line], [Aspect Blanking-Half], [Aspect Blanking-Black], [Difference], [Horopter Check], [Flip H].
- Use the BKM-16R with software version 1.5 or higher or BKM-17R to assign [Checkerboard] and [L/R Switch].
- Use the BKM-16R with software version 1.4 or higher or BKM-17R to assign [Audio Level Meter], [ALM Hold Reset] and [Time Code].
- Use the BKM-16R with software version 1.3 or higher or BKM-17R to assign [Black Detail Mode].
- Use the BKM-17R to assign [Flicker Free].

Submenu	Setting
[F1]-[F16]	The following functions are assigned. <ul style="list-style-type: none"> <li>[<b>Scan Mode</b>]: Changes the scan mode of the picture.</li> <li>[<b>Native Scan</b>]: Displays the picture in native scan mode.</li> </ul>

Submenu	Setting
	<ul style="list-style-type: none"> <li>[<b>16:9</b>]: Changes the aspect ratio to 16:9 or 1.896:1 (digital cinema signal), and when set to Off, the aspect ratio changes to 4:3 or 2.39:1. The aspect ratio of some signals is fixed to 16:9 depending on the signal format. <i>For details, see “Available Signal Formats” on page 80.</i></li> <li>[<b>H Delay</b>]: The picture moves horizontally and a horizontal sync signal appears. Brightness of the picture increases automatically, and makes it easy to check the sync part. When the V Delay button is set to on in H delay mode, a pulse cross picture is displayed.</li> <li>[<b>V Delay</b>]: The picture moves vertically and a vertical sync signal appears approximately in the center of the screen. The brightness of the picture increases automatically, and makes it easy to check the sync part. When the H Delay button is set to on in V delay mode, a pulse cross picture is displayed.</li> <li>[<b>External Sync</b>]<sup>1)</sup>: Sets whether or not to set to the external sync mode when the analog component signal or analog RGB signal is input. When the button is set to on, the signal to be displayed is synchronized with the sync signal input to the EXT SYNC connector (External Sync). When set to off, the signal to be displayed is synchronized with the sync signal included in the signals being monitored (Internal Sync).</li> </ul>

### Note

When the button is set to off (Internal Sync), a sync signal is added on the Y signal to monitor the analog component signal and on the G signal to monitor the analog RGB signal.

- [**Comb**]<sup>1)</sup>: The comb filter is turned on. When the button is set to off, the trap-band-pass filter is selected. When the displayed signal is NTSC, PAL, or PAL-M, this functions.
- [**Char Off**]: The characters on the monitor screen hide during manual adjustment.
- [**Color Temp**]: You can directly access the [Manual Adjust] menu of the [Color Temp Adj] menu.

Submenu	Setting
	<ul style="list-style-type: none"> <li>• <b>[Status]</b>: Various status information regarding the monitor are displayed on a single page. <i>For details on the display, see "Displaying the Monitor Status Page" (page 70).</i></li> <li>• <b>[Aperture]</b>: When the function is set to on, the frequency response can be modified. The degree of modification is set in the [Aperture Value] menu (page 42) of the [Auxiliary Setting] menu. <i>For information about the aperture modification frequency for each signal system, see "Aperture Modification Frequency" on page 85.</i></li> <li>• <b>[Mono]</b>: When the button is set to on, a monochrome picture is displayed. When the button is set to off, the monitor switches automatically between color and monochrome mode depending on the color discrimination of the input adaptor.</li> <li>• <b>[Blue Only]</b>: Red and green signals are cut, and only the blue signal is displayed as a monochrome picture. It makes it easy to adjust chroma and phase, and to check VTR noise.</li> <li>• <b>[R Off]</b>: R (red) signals are cut respectively.</li> <li>• <b>[G Off]</b>: G (green) signals are cut respectively.</li> <li>• <b>[B Off]</b>: B (blue) signals are cut respectively.</li> <li>• <b>[Chroma Up]</b>: The chroma setting increases by 12 dB.</li> <li>• <b>[Interlace]</b>: Displays in the interlace mode.</li> <li>• <b>[Pixel Zoom]</b>: The part of the picture is magnified up to 8 times (page 48).</li> <li>• <b>[Capture Load]</b>: Displays the menu to load the captured picture from the USB memory, etc.</li> <li>• <b>[Marker]</b>: All markers are displayed on the screen.</li> <li>• <b>[Aspect Marker]</b>: An aspect marker is displayed on the screen.</li> <li>• <b>[Area Marker 1]</b>: An area marker 1 is displayed on the screen.</li> <li>• <b>[Area Marker 2]</b>: An area marker 2 is displayed on the screen.</li> <li>• <b>[Center Marker]</b>: The center marker is displayed on the screen.</li> <li>• <b>[Aspect Marker-Line]</b>: The line of the aspect marker is displayed on the screen.</li> </ul>

Submenu	Setting
	<ul style="list-style-type: none"> <li>• <b>[Aspect Blanking-Half]</b>: Aspect Blanking is set to half blanking.</li> <li>• <b>[Aspect Blanking-Black]</b>: The blanking level of Aspect Blanking is set to [0%] black level.</li> <li>• <b>[Side by Side]</b>: The screen is displayed in the side by side display mode.</li> <li>• <b>[Wipe]</b>: The screen is displayed in the wipe display mode.</li> <li>• <b>[Butterfly]</b>: The screen is displayed in the butterfly display mode.</li> <li>• <b>[Blending]</b>: The screen is displayed in the blending display mode.</li> <li>• <b>[Error Notify Clear]</b>: Clears the notification detected in the gamut error detection. ([OSD Notification])</li> <li>• <b>[Audio Level Meter]</b>: The audio level meter is displayed.</li> <li>• <b>[ALM Hold Reset]</b>: The peak hold of the audio level meter is canceled.</li> <li>• <b>[Time Code]</b>: The time code is displayed.</li> <li>• <b>[Difference]</b> <sup>1)</sup>: The difference between the luminance of the left 3D video signal and that of the right signal is displayed.</li> <li>• <b>[Checkerboard]</b> <sup>1)</sup>: The left and right 3D video signals are displayed in a checkerboard pattern.</li> <li>• <b>[L/R Switch]</b> <sup>1)</sup>: The left and right 3D video signals are displayed alternately by switching.</li> <li>• <b>[Horopter Check]</b> <sup>1)</sup>: The left and right 3D video signals are displayed.</li> <li>• <b>[Flip H]</b> <sup>1)</sup>: The 3D video signals are inverted horizontally and displayed.</li> <li>• <b>[Black Frame Insertion]</b> <sup>1)</sup>: The signal is displayed in black frame insertion mode.</li> <li>• <b>[Black Detail Mode]</b> <sup>1)</sup>: The signal is displayed in black detail mode.</li> <li>• <b>[Degauss]</b> <sup>1)</sup>: The CRT is degaussed.</li> <li>• <b>[Flicker Free]</b>: Displays without flicker.</li> </ul>

1) Only function assigning is available with this monitor.

## Assigning a Function to a Function Button

- 1 Select the [Function Key] menu in the [Controller] menu.
- 2 Select the [F1] to [F16] button, and then the function assigned on each button.

## Assignable functions

[Scan Mode Skip], [Native Scan], [16:9], [H Delay], [V Delay], [External Sync], [Comb], [Char Off], [Color Temp], [STATUS], [Aperture], [Mono], [Blue Only], [R Off], [G Off], [B Off], [Chroma Up], [Interlace], [Pixel Zoom], [Capture Load], [Marker], [Aspect Marker], [Area Marker 1], [Area Marker 2], [Center Marker], [Aspect Marker-Line], [Aspect Blanking-Half], [Aspect Blanking-Black], [Side by Side], [Wipe], [Butterfly], [Blending], [Error Notify Clear], [Audio Level Meter], [ALM Hold Reset], [Time Code], [Difference], [Checkerboard], [L/R Switch], [Horopter Check], [Flip H], [Black Frame Insertion], [Black Detail Mode], [Degauss], [Flicker Free]

For details on the assigned function, see [Function Key] (page 67) in the [Controller] menu.

## Displaying the Assigned Functions Collectively

When no menu is displayed on the screen, press the ENTER button on the controller. The functions assigned to function buttons F1 to F8 are displayed on the screen.



Press the ENTER button again to display the functions assigned to function buttons F9 to F16.

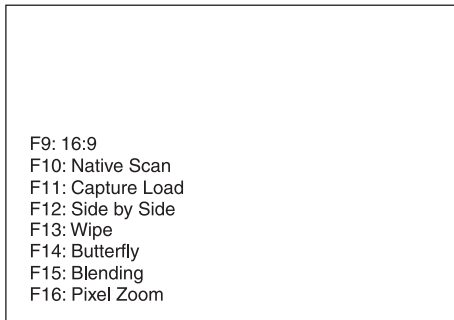

If you press the ENTER button once again, the collective display will disappear.

The following functions are displayed as an abbreviation.

- **[Aspect Marker-Line]:** [A-Marker Line]
- **[Aspect Blanking-Half]:** [A-Blank Half]
- **[Aspect Blanking-Black]:** [A-Blank Black]
- **[Error Notify Clear]:** [Error Clear]
- **[Black Frame Insertion]:** [Black Frame]
- **[Black Detail Mode]:** [Black Detail]
- **[Audio Level Meter]:** [ALM]

- **[ALM Hold Reset]:** [ALM Hold Rst]
- **[Horopter Check]:** [Horopter]

## Notes

- Use the BKM-16R with software version 1.7 or higher or BKM-17R to display the functions assigned to the function buttons collectively.
- [Pixel Zoom] is not set to on when the list of the functions assigned to the function buttons is displayed.
- The UP/DOWN buttons and the PHASE knob on the controller are disabled when the list of the functions assigned to the function buttons is displayed.

## [Monitor ID Display]

Sets display mode of the display window.

- **[On]:** Always displayed.
- **[Auto]:** Displayed during operation by the remote connection and disappears automatically after operation.
- **[Off]:** Not displayed.

## [Controller Upgrade]

Upgrades the controller.

When the item is selected, the screen for inputting the password is displayed.

After the 4-digit password is entered, the current versions of [Software Version] and [Kernel Version] are displayed.

For the password, see [Password] (page 61) of the [System Configuration] menu.

For details on upgrading the controller, see “Upgrading the Monitor and Controller” on page 72.

Submenu	Setting
[Software Upgrade]	Upgrades the software for the controller.
[Kernel Upgrade]	Upgrades the kernel of the controller.

## [Key Protect] Menu

This menu is used to lock the data so that the setting is not changed by an unauthorized user.

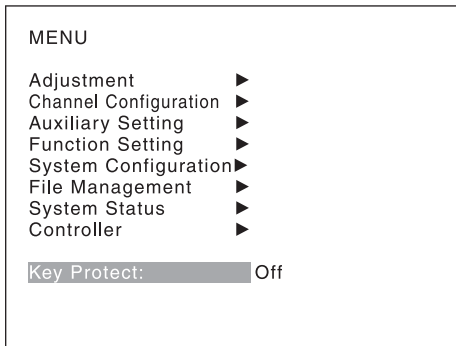

Submenu	Setting
[Key Protect]	Sets the key protection. <ul style="list-style-type: none"> <li>• <b>[On]:</b> The button on the controller (except the menu operation buttons and monitor selection buttons) and the parallel remote do not function and other settings are not changeable.</li> <li>• <b>[Off]:</b> Release the lock.</li> </ul>

## Displaying the Monitor Status Page

When Status has been assigned to a function button of the controller, various information, such as the setting status, display mode, and input signal information of the currently displayed video signal, are displayed on the monitor status pages.

For how to assign a function to a function button, see “Assigning a Function to a Function Button” (page 68).

### Note

[Pixel Zoom] is not set to on when the monitor status page is displayed.

**1** Press the STATUS button on the controller to set it to On.

Page 1/3 of [STATUS] display is displayed.

**2** Select the [STATUS] page you wish to view using the UP/DOWN button on the controller.

You can select the [STATUS] page from among 1/3, 2/3, and 3/3.

For the contents of each page, see below.

### To cancel the display of the [STATUS] page

Press the STATUS button on the controller again.

### Page 1/3

Information on the setting status of the input signal and the display mode is displayed.

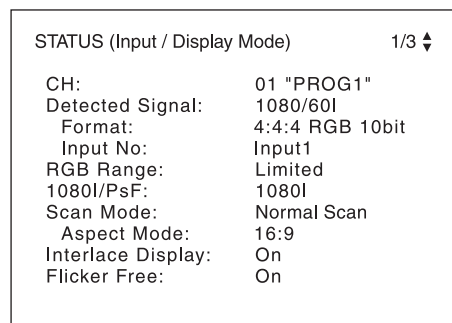

**[CH]:** Displays the currently selected channel number and channel name.

**[Detected Signal]:** Displays the signal system with the format detected.

**[Format]:** Displays [Format] set in the [Channel Configuration] menu.

**[Input No]:** Displays [Input No] set in the [Channel Configuration] menu.

**[RGB Range]:** Displays [RGB Range] set in the [Channel Configuration] menu.

**[1080I/PsF]:** Displays [1080I/PsF] set in the [Channel Configuration] menu.

**[Scan Mode]:** Displays the selected scan mode.

**[Aspect Mode]:** Displays the selected aspect ratio.

**[Interlace Display]:** Displays On/Off of the interlace display.

**[Flicker Free]:** Displays On/Off of flicker free.

## Page 2/3

Information on the picture adjustments is displayed.

STATUS (Picture Configuration) 2/3 ⚡	
CH01	
Matrix:	ITU-R BT.709
Color Profile:	BVM-EBU
Color Space:	EBU
Gamma:	CRT BVM
Color Temp:	User1
Picture Preset: Preset1	
Chroma:	1000
Bright:	000
Contrast:	1000

**[Matrix]:** Displays [Matrix] set in the [Channel Configuration] menu.

**[Color Profile]:** Displays [Color Profile] set in the [Channel Configuration] menu.

**[Color Space]:** Displays [Color Space] set in [Color Profile].

**[Gamma]:** Displays [Gamma] set in [Color Profile]

**[Color Temp]:** Displays [Color Temp] set in the [Channel Configuration] menu.

**[Picture Preset]:** Displays [Picture Preset] set in the [Channel Configuration] menu.

**[Chroma]:** Displays the [Chroma] value of the selected [Picture Preset].

**[Bright]:** Displays the [Bright] value of the selected [Picture Preset].

**[Contrast]:** Displays the [Contrast] value of the selected [Picture Preset].

## Page 3/3

### When the SDI signal is input

The same information as that of [SDI Payload ID Status] in the [System Status] menu is displayed.

STATUS (SDI Payload ID) 3/3 ⚡	
Input1	
Payload ID	B1 B2 B3 B4
Video Standard:	HD-SDI
Sampling Structure:	4:2:2 Y/Cb/Cr
Bit Depth:	10bit
Picture Rate:	59.94
Scanning Method:	Interlace/Interlace
Link Number:	Single/Link_1
Current Status	
Format:	HD 422 YCbCr 10
I/PsF/P:	Interlace

**InputX:** Input connector [Input1], [Input2], or [Input1&2] of the displayed information is displayed.

**[Payload ID]:** Displays the 4-byte data for Payload ID of the SMPTE-352M standard in hexadecimal in sequence of Byte 1, Byte 2, Byte 3, and Byte 4.

When the Payload ID information is not set, only [Current Status] is displayed, and [---] is displayed for other items. When the following information is not decoded, [Unknown] is displayed.

**[Video Standard]:** Decode display of Byte 1\_Bit 6-0

**[Sampling Structure]:** Decode display of Byte 3\_Bit 3-0

**[Bit Depth]:** Decode display of Byte 4\_Bit 1-0

**[Picture Rate]:** Decode display of Byte 2\_Bit 3-0

**[Scanning Method]:** Decode display of Byte 2\_Bit 7/Byte 2\_Bit 6

**[Link Number]:** Decode display of Byte 4\_Bit 7-6

**[Current Status]:** Displays the current status of the monitor.

**[Format]:** Displayed as “[Video Standard] + [Sampling Structure] + [Bit Depth]”.

**[Video Standard]:** 3G / DL / HD / SD

**[Sampling Structure]:** 422 YCbCr / 444 YCbCr / 444 RGB / 444 XYZ

**[Bit Depth]:** 10 / 12

**[I/PsF/P]:** [Interlace] / [PsF] / [Progressive]

### When the HDMI signal is input

The same information as that of [HDMI Status] in the [System Status] menu is displayed.

STATUS (HDMI) 3/3 ⚡	
CH01	
Pixel Encoding:	YCbCr 4:4:4
Color Depth:	12bit
Colorimetry:	ITU-R BT.601
RGB Range:	---

**[Pixel Encoding]:** [RGB 4:4:4] / [YCbCr 4:4:4] / [YCbCr 4:2:2]

**[Color Depth]:** [8bit] / [10bit] / [12bit]

**[Colorimetry] <sup>1)</sup>:** [ITU-R BT.601] / [ITU-R BT.709] / [ITU-R BT.2020]

[RGB Range] <sup>2)</sup>: [Limit] / [Full]

- 1) It is displayed when [HDMI Auto] is set to [On] in the [Matrix] menu of the [Channel Configuration] menu.
- 2) It is displayed when [HDMI Auto] is set to [On] in the [RGB Range] menu of the [Channel Configuration] menu.

---

## Upgrading the Monitor and Controller

You can upgrade the monitor and controller with the data.

You can upgrade the following data:

**Monitor:** Software program, Kernel, FPGA data

**Controller:** Software program, Kernel

### Notes

- Use the BKM-16R with software version 1.7 or higher or BKM-17R to upgrade the monitor.
- When the unit is upgraded, use the AC power supply for the monitor.
- Do not turn off the power of the monitor and controller during upgrade.
- When you use the BKM-17R:  
Use a USB memory stick for upgrading.  
If a memory other than USB memory stick is used, the upgrading may not be executed correctly.  
To initialize the USB memory stick, use the file system FAT32. If the USB memory stick is initialized using a system other than file system FAT32, the upgrading may not be executed correctly.
- When you use the BKM-16R:  
Upgrading of the software for the controller is available for version 1.11 or later and upgrading of the controller kernel is available for version 1.2 or later.  
Use “Memory Stick PRO” for upgrading.  
If a “Memory Stick” other than “Memory Stick PRO” is used, the upgrading may not be executed correctly.  
To initialize “Memory Stick PRO”, use a machine and application corresponding to “Memory Stick PRO”. If Windows Explorer is used for initialization, the upgrading may not be executed correctly.

### To get the upgrade data

Contact your Sony representative.

---

## Saving the Upgrade Data in a USB memory stick, etc.

Save the upgrade data (MSSONY folder) in a USB memory stick, etc.

Save the whole MSSONY folder directly in the root directory of the drive.

### To confirm saving the data correctly

Double-click on the file including checksum.bat in the file name.

BVM-E251





flashing during upgrade, but the data are being upgraded correctly.

**Notes**

- Do not remove the USB memory stick, etc. from the controller during upgrading or disconnect the LAN cable between the monitor and controller.
- Do not turn off the power of the monitor and controller during upgrade.

After completion of upgrade, the display on the screen disappears, and the system is restarted. After restarting, the previous screen is displayed.

- 6 Select the [Monitor Upgrade] menu in the [System Configuration] menu and confirm that the version of the selected item has been upgraded.

When the upgrade sequence does not move forward correctly, the message such as [Procedure failure] is displayed in red.

If this error message is displayed, contact your Sony representative.

---

## Upgrading the Controller

- 1 Connect a USB memory stick to the USB connector of the controller.

**Note**

When you use the BKM-16R, insert “Memory Stick PRO” into the Memory Stick insertion slot of the controller.

- 2 Select the [Controller Upgrade] menu in the [Controller] menu (page 69).

- 3 Enter the 4-digit password.

The [Controller Upgrade] screen is displayed and the current version is indicated.

*For the password, see [Password] (page 61) of the [System Configuration] menu.*

- 4 Select the item to upgrade from [Software Upgrade] or [Kernel Upgrade].

After about 10 seconds, the old and new software versions or kernel version, and the message to confirm that you wish to execute the upgrade are displayed.

**Display example**

Controller software will be upgraded and monitor will restart.

Are you sure ?

- 5 Confirm the data version and press the ENTER (Ent) button.

Upgrading starts.

**When a version earlier than 1.2 of the software for the controller is upgraded (only for BKM-16R)**

When upgrading starts, the dot (indicator) lights moving from left to right in the display window of the controller. The dot may stop during upgrade, but the data is being upgraded correctly.

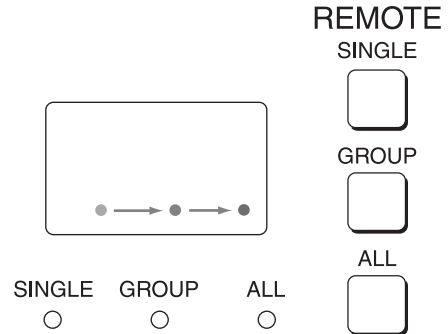

**When version 1.2 or later of the software for the controller is upgraded**

When upgrade starts, the indicator lights turning clockwise in the display window of the controller. The indicator may stop during upgrade, but the data is being upgraded correctly.

After upgrading, all indicators light for about 1 second.

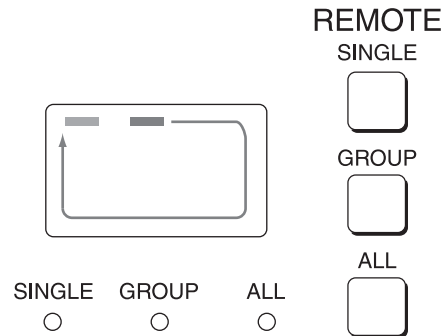

**Notes**

- Do not remove the USB memory stick from the controller during upgrade or disconnect the LAN cable between the monitor and controller.
- Do not turn off the power of the monitor and controller during upgrade.

After completion of upgrade, the system is restarted. The network between the monitor and controller is reconnected, and you can operate the controller.

When the upgrade sequence does not move forward correctly, the error message [Err] is displayed in the display window. If this error

message is displayed, contact your Sony representative.

- 6 Exit the [Controller Upgrade] menu, select the [Controller Upgrade] menu again, and confirm that the version of the selected item has been upgraded.

---

## Connecting the SDI Signals

Single Link 3G/HD-SDI and Dual Link HD-SDI signals can be input to the SDI 1 IN and SDI 2 IN connectors of this unit.

Signals up to 2-channel Single Link 3G/HD-SDI signals or 1-channel Dual Link HD-SDI signals can be input to the SDI 1 IN connector and the SDI 2 IN connector respectively. Use the appropriate input connectors depending on the input signal, referring to the tables below.

### Connecting the Dual Link HD-SDI signal

Connector	Input signal
SDI IN <b>1</b>	HD-SDI Link 1
SDI IN <b>2</b>	HD-SDI Link 2

# Troubleshooting

This section may help you isolate the cause of a problem and as a result, eliminate the need to contact technical support.

- **The picture that you wish to display is not displayed.** → The setting of the [Channel Configuration] menu does not correspond to the input signal. See the [System Status] menu (page 64) to confirm the setting. When the setting is different from the input signal, set in the [Channel Configuration] menu correctly (page 35).
- **The color is not displayed correctly.** → Set the color temperature in the [Color Temp] menu (page 36) of the [Channel Configuration] menu. Or set in the [Color Profile] menu (page 39) or [Matrix] menu (page 38) of the [Channel Configuration] menu. When the settings are different from the above, set them correctly.
- **The signals are not displayed in the multi display.** → The reference signal is not input (No Sync status). Input the reference signal. The internal signal is not displayed in the multi display.
- **The phase of signal B in the multi display slips.** → Genlock signal A and signal B to use the wipe mode and blending mode.
- **The pixel zoom does not function.** → The pixel zoom is valid when the native scan mode is selected. Set to the native scan mode (page 56).
- **The marker is not displayed.** → When the display is set in the multi display, set [Side by Side], [Wipe], [Butterfly], or [Blending] to [Off] in the [Function Switch] menu (page 52) of the [Function Setting] menu. When the pixel zoom display is set, set the PIXEL ZOOM button to off. The marker is not displayed in the following:
  - when the computer signal via HDMI is displayed
  - when the internal signal is displayed
  - when the signal is displayed in H delay mode or V delay mode.
- **The signal is not displayed in interlace mode.** → Confirm the following:
  - whether the interlace signal is input or not
  - whether the signal is set to [1080I] in [1080I/PsF] (page 41) of the [Channel Configuration] menu or not
  - whether the native scan mode is selected or not. (page 56)
- **The setting is different from the setting in the menu.** → When the setting has been changed with the function button of the controller after setting in the menu, the last setting becomes effective.

- **The function button of the controller does not function.** → When the setting has been changed in the menu after setting with the function button, the last setting becomes effective.
- **The function of the function button on the controller is different from that of the panel display.** → See the [Function Key] menu (page 67) of the [Controller] menu to confirm the function assigned to the function button.
- **The Gamut Error message does not go off.** → A gamut error is detected or [OSD Notification Reset] is set to [Manual] and the detected error information is remained. Perform the following.
  - Set [Gamut Error Display] to [Off] in the [Gamut Error Display] menu of the [Function Setting] menu (page 49).
  - Set [OSD Notification Reset] to [Auto] in the [Gamut Error Display] menu of the [Function Setting] menu (page 49).
  - Press the function button with the [Error Notify Clear] function assigned in the [Function Key] menu of the [Controller] menu (page 68).
  - Set the pin of the PARALLEL REMOTE connector with the [Error Notify Clear] function assigned in the [Parallel Remote] menu of the [System Configuration] menu to [On] (page 58).
  - Select [Error Notify Clear] in the [Function Switch] menu of the [Function Setting] menu (page 55).
- **The zebra pattern does not go off.** → When a gamut error is detected, set [Gamut Error Display] to [Off] in the [Gamut Error Display] menu of the [Function Setting] menu (page 49). When an Over Range error is detected, the zebra pattern is set to be displayed in the Over Range portion, and the detected Over Range information is retained. Set [Over Range] to [Off] in the [On Screen Set] menu of the [System Configuration] menu (page 61).

## Note

If the OVER RANGE indicator lights, adjust the contrast or brightness to a lower level.

# Specifications

## BVM-E251

### Picture performance

Panel	OLED panel
Picture size (diagonal)	623.4 mm (24 <sup>5</sup> / <sub>8</sub> inches)
Effective picture size (H × V)	543.4 × 305.6 mm (21 <sup>1</sup> / <sub>2</sub> × 12 <sup>1</sup> / <sub>8</sub> inches)
Resolution (H × V)	1920 × 1080 pixels (Full HD)
Aspect	16:9
Pixel efficiency	99.99%
Panel drive	RGB 10-bit
Panel display frame rate	48 Hz, 50 Hz, 60 Hz <sup>1)</sup> See “Picture Frame Display” (page 89).
Viewing angle (Panel specification)	89°/89°/89°/89° (typical) (up/down/left/right, contrast > 10:1)
Normal scan	0% scan
Native scan	Mapping the pixels of the signal to the panel to one-to-one mode, or displaying an SD signal of non-square pixels (the number of H pixels of the signal system is 720 or 1440) or a 640 × 480 SD signal of HDMI video by scaling processing of doubling for the V direction and correct aspect ratio for the H direction and also optimizing and displaying a picture by modifying the aperture coefficient value, filter coefficient value, etc.
Under scan	3% under scan
Over scan	Mask of 5% over scan portion in the normal scan
Color temperature	D55, D61, D65, D93, DCI <sup>2)</sup> (Setting possible in other color temperature)
Standard luminance (100% white signal input)	100 cd/m <sup>2</sup> (Preset1-Preset5) 48 cd/m <sup>2</sup> (Preset(DCI))
Color space (color gamut)	ITU-R BT.709, EBU, SMPTE-C, DCI-P3 <sup>3)</sup> , E251 Native <sup>4)</sup> , S-GAMUT/S-GAMUT3 <sup>5)</sup> , S-GAMUT3.Cine, ITU-R BT.2020
Warm-up time	Approx. 30 minutes To provide stable picture quality, turn on the power of the monitor and

leave it in this state for more than 30 minutes.

- 1) 48 Hz and 60 Hz are compatible with a frame rate of 1/1.001.
- 2) DCI: x=0.314 y=0.351
- 3) Chromaticity points of SMPTE RP 431-2, ITU-R BT.2020, S-Gamut/S-Gamut3, and S-Gamut3.Cine are not covered in full.
- 4) The BVM-E251 individual chromaticity points. The widest color space setting of the signal reproduced by the BVM-E251

	x	y
R	0.681	0.319
G	0.189	0.724
B	0.141	0.051

(Typical)

- 5) For displaying the color space of the wide color space mode which is available for the F65 or PMW-F55/F5 CineAlta 4K Camera, etc.

### Input

SDI	BNC (×2) Input impedance: 75 ohms unbalanced Signal format: See “Available Signal Formats” (page 80). Sampling frequency 3G-SDI: Y/Cb/Cr (4:2:2): 148.5 MHz/74.25 MHz/74.25 MHz Y/Cb/Cr (4:4:4): 74.25 MHz/74.25 MHz/74.25 MHz G/B/R (4:4:4): 74.25 MHz/74.25 MHz/74.25 MHz HD-SDI: Y/Cb/Cr (4:2:2): 74.25 MHz/37.125 MHz/37.125 MHz SD-SDI: Y/Cb/Cr (4:2:2): 13.5 MHz/6.75 MHz/6.75 MHz Quantization 3G-SDI: 10bit/sample, 12bit/sample HD-SDI: 10bit/sample SD-SDI: 10bit/sample
Composite input (NTSC/PAL/PAL-M)	BNC type (×1) 1 V <sub>p-p</sub> ±3 dB sync negative
HDMI	HDMI (×1) HDCP1.4 correspondence, Deep Color correspondence Signal format: See “HDMI” (page 84) of “Available Signal Formats”.
Parallel remote	RJ-45 (×1)
Serial remote (LAN)	Ethernet (10BASE-T/100BASE-TX) RJ-45 (×1)

## Output

SDI	BNC (×2) (monitor output) Output signal amplitude: 800 mVp- p±10% Output impedance: 75 ohms unbalanced Transmission distance: 3G-SDI: 70 m max. <sup>1)</sup> HD-SDI: 100 m max. <sup>1)</sup> SD-SDI: 200 m max. <sup>2)</sup>
-----	---

### Composite output

BNC type (×1)  
Loop-through <sup>3)</sup>, with 75 ohms  
automatic terminal function

### DC 12V OUT

Circle 4-pin (female) (×1)

- 1) When using the 5C-FB coaxial cable made by Fujikura Ltd. or equivalent
- 2) When using the 5C-2V coaxial cable made by Fujikura Ltd. or equivalent
- 3) When the unit is turned off, the signal wave may be distorted.

## General

### Power requirements

100 V to 240 V AC, 1.2 A to 0.6 A, 50/  
60 Hz  
24 V to 28 V DC, 4.5 A to 3.9 A

### Power consumption

Approx. 117 W (when AC power  
source is used) / Approx. 107 W  
(when DC power source is used)  
(max.)  
Approx. 55 W (when AC power source  
is used) / Approx. 51 W (when DC  
power source is used) (average  
power consumption in the default  
status)

### Operating temperature

0 °C to 35 °C (32 °F to 95 °F)  
Recommended: 20 °C to 30 °C (68 °F to  
86 °F)

### Operating humidity

30% to 85% (no condensation)

### Storage/transport temperature

-20 °C to +60 °C (-4 °F to +140 °F)

### Storage/transport humidity

0% to 90%

### Operating/storage/transport pressure

700 hPa to 1060 hPa

### Mass

Approx. 10.3 kg (22 lb 11 oz)

### Accessories supplied

AC power cord (1)  
AC plug holder (1)  
HDMI cable holder (1)  
Before Using This Unit (1)  
CD-ROM (1)  
European Representative (1)

### Optional accessories

BKM-17R/BKM-16R Monitor Control  
Unit  
BKM-37H/BKM-38H Controller  
Attachment Stand  
SMF-17R20 Monitor Interface Cable

---

## BVM-E171

### Picture performance

Panel	OLED panel
Picture size (diagonal)	419.7 mm (16 1/2 inches)
Effective picture size (H × V)	365.8 × 205.7 mm (14 1/2 × 8 1/8 inches)
Resolution (H × V)	1920 × 1080 pixels (Full HD)
Aspect	16:9
Pixel efficiency	99.99%
Panel drive	RGB 10-bit
Panel display frame rate	48 Hz, 50 Hz, 60 Hz <sup>1)</sup> See "Picture Frame Display" (page 89).
Viewing angle (Panel specification)	89°/89°/89°/89° (typical) (up/down/left/right, contrast > 10:1)
Normal scan	0% scan
Native scan	Mapping the pixels of the signal to the panel to one-to-one mode, or displaying an SD signal of non- square pixels (the number of H pixels of the signal system is 720 or 1440) or a 640 × 480 SD signal of HDMI video by scaling processing of doubling for the V direction and correct aspect ratio for the H direction and also optimizing and displaying a picture by modifying the aperture coefficient value, filter coefficient value, etc.
Under scan	3% under scan
Over scan	Mask of 5% over scan portion in the normal scan
Color temperature	D55, D61, D65, D93, DCI <sup>2)</sup> (Setting possible in other color temperature)
Standard luminance (100% white signal input)	100 cd/m <sup>2</sup> (Preset1-Preset5) 48 cd/m <sup>2</sup> (Preset(DCI))
Color space (color gamut)	ITU-R BT.709, EBU, SMPTE-C, DCI- P3 <sup>3)</sup> , E171 Native <sup>4)</sup> , S-GAMUT/S- GAMUT3 <sup>5)</sup> , S-GAMUT3.Cine, ITU-R BT.2020

Warm-up time Approx. 30 minutes

To provide stable picture quality, turn on the power of the monitor and leave it in this state for more than 30 minutes.

- 1) 48 Hz and 60 Hz are compatible with a frame rate of 1/1.001.
- 2) DCI:  $x=0.314$   $y=0.351$
- 3) Chromaticity points of SMPTE RP 431-2, ITU-R BT.2020, S-Gamut/S-Gamut3, and S-Gamut3.Cine are not covered in full.
- 4) The BVM-E171 individual chromaticity points. The widest color space setting of the signal reproduced by the BVM-E171

	x	y
R	0.681	0.319
G	0.189	0.724
B	0.141	0.051

(Typical)

- 5) For displaying the color space of the wide color space mode which is available for the F65 or PMW-F55/F5 CineAlta 4K Camera, etc.

## Input

**SDI** BNC (×2)  
Input impedance: 75 ohms unbalanced  
Signal format: See “Available Signal Formats” (page 80).  
Sampling frequency  
3G-SDI:  
Y/Cb/Cr (4:2:2): 148.5 MHz/74.25 MHz/74.25 MHz  
Y/Cb/Cr (4:4:4): 74.25 MHz/74.25 MHz/74.25 MHz  
G/B/R (4:4:4): 74.25 MHz/74.25 MHz/74.25 MHz  
HD-SDI:  
Y/Cb/Cr (4:2:2): 74.25 MHz/37.125 MHz/37.125 MHz  
SD-SDI:  
Y/Cb/Cr (4:2:2): 13.5 MHz/6.75 MHz/6.75 MHz  
Quantization  
3G-SDI: 10bit/sample, 12bit/sample  
HD-SDI: 10bit/sample  
SD-SDI: 10bit/sample

**Composite input (NTSC/PAL/PAL-M)**  
BNC type (×1)  
1 Vp-p ±3 dB sync negative

**HDMI** HDMI (×1)  
HDCP1.4 correspondence, Deep Color correspondence  
Signal format: See “HDMI” (page 84) of “Available Signal Formats”.

**Parallel remote** RJ-45 (×1)

**Serial remote (LAN)**  
Ethernet (10BASE-T/100BASE-TX)

RJ-45 (×1)

## Output

**SDI** BNC (×2) (monitor output)  
Output signal amplitude: 800 mVp-p ±10%  
Output impedance: 75 ohms unbalanced  
Transmission distance:  
3G-SDI: 70 m max. <sup>1)</sup>  
HD-SDI: 100 m max. <sup>1)</sup>  
SD-SDI: 200 m max. <sup>2)</sup>

### Composite output

BNC type (×1)  
Loop-through <sup>3)</sup>, with 75 ohms automatic terminal function

**DC 12V OUT** Circle 4-pin (female) (×1)

- 1) When using the 5C-FB coaxial cable made by Fujikura Ltd. or equivalent
- 2) When using the 5C-2V coaxial cable made by Fujikura Ltd. or equivalent
- 3) When the unit is turned off, the signal wave may be distorted.

## General

### Power requirements

100 V to 240 V AC, 0.9 A to 0.5 A, 50/60 Hz  
24 V to 28 V DC, 3.3 A to 2.9 A

### Power consumption

Approx. 88 W (when AC power source is used) / Approx. 78 W (when DC power source is used) (max.)  
Approx. 53 W (when AC power source is used) / Approx. 49 W (when DC power source is used) (average power consumption in the default status)

### Operating temperature

0 °C to 35 °C (32 °F to 95 °F)  
Recommended: 20 °C to 30 °C (68 °F to 86 °F)

### Operating humidity

30% to 85% (no condensation)

### Storage/transport temperature

-20 °C to +60 °C (-4 °F to +140 °F)

### Storage/transport humidity

0% to 90%

### Operating/storage/transport pressure

700 hPa to 1060 hPa

**Mass** Approx. 6.5 kg (14 lb 5.3 oz)

### Accessories supplied

AC power cord (1)  
AC plug holder (1)  
HDMI cable holder (1)  
Rack mount bracket (Left, right, each 1)

- Handle (1)
- Screws (6)
- Before Using This Unit (1)
- CD-ROM (1)
- European Representative (1)
- Optional accessories
  - BKM-17R/BKM-16R Monitor Control Unit
  - BKM-39H Controller Attachment Stand
  - SMF-17R20 Monitor Interface Cable

Design and specifications are subject to change without notice.

SONY WILL NOT BE LIABLE FOR DAMAGES OF ANY KIND RESULTING FROM A FAILURE TO IMPLEMENT PROPER SECURITY MEASURES ON TRANSMISSION DEVICES, UNAVOIDABLE DATA LEAKS RESULTING FROM TRANSMISSION SPECIFICATIONS, OR SECURITY PROBLEMS OF ANY KIND.

Depending on the operating environment, unauthorized third parties on the network may be able to access the unit. When connecting the unit to the network, be sure to confirm that the network is protected securely.

Notes

- Always verify that the unit is operating properly before use. SONY WILL NOT BE LIABLE FOR DAMAGES OF ANY KIND INCLUDING, BUT NOT LIMITED TO, COMPENSATION OR REIMBURSEMENT ON ACCOUNT OF THE LOSS OF PRESENT OR PROSPECTIVE PROFITS DUE TO FAILURE OF THIS UNIT, EITHER DURING THE WARRANTY PERIOD OR AFTER EXPIRATION OF THE WARRANTY, OR FOR ANY OTHER REASON WHATSOEVER.
- SONY WILL NOT BE LIABLE FOR CLAIMS OF ANY KIND MADE BY USERS OF THIS UNIT OR MADE BY THIRD PARTIES.
- SONY WILL NOT BE LIABLE FOR THE TERMINATION OR DISCONTINUATION OF ANY SERVICES RELATED TO THIS UNIT THAT MAY RESULT DUE TO CIRCUMSTANCES OF ANY KIND.

## Available Signal Formats

The unit is applicable to the following signal formats.

### Composite

Signal System	Signal Structure	Quantization
720 <sup>2)</sup> × 487/59.94/I	NTSC 0/7.5	Limited
720 <sup>2)</sup> × 487/59.94/I	PAL-M	Limited
720 <sup>2)</sup> × 576/50/I	PAL	Limited

### SD-SDI

Signal System	Signal Structure	Quantization
720 × 487/59.94/I	4 : 2 : 2 (YCbCr) 10bit	Limited
720 × 576/50/I	4 : 2 : 2 (YCbCr) 10bit	Limited



## HD-SDI Single Link

Signal System	Signal Structure	Quantization
1920 × 1080/50/I	4 : 2 : 2 (YCbCr) 10bit	Limited
1920 × 1080/60 <sup>1)</sup> /I	4 : 2 : 2 (YCbCr) 10bit	Limited
1280 × 720/50/P	4 : 2 : 2 (YCbCr) 10bit	Limited
1280 × 720/60 <sup>1)</sup> /P	4 : 2 : 2 (YCbCr) 10bit	Limited
1920 × 1080/24 <sup>1)</sup> /PsF	4 : 2 : 2 (YCbCr) 10bit	Limited
1920 × 1080/24 <sup>1)</sup> /P	4 : 2 : 2 (YCbCr) 10bit	Limited
1920 × 1080/25/PsF	4 : 2 : 2 (YCbCr) 10bit	Limited
1920 × 1080/25/P	4 : 2 : 2 (YCbCr) 10bit	Limited
1920 × 1080/30 <sup>1)</sup> /PsF	4 : 2 : 2 (YCbCr) 10bit	Limited
1920 × 1080/30 <sup>1)</sup> /P	4 : 2 : 2 (YCbCr) 10bit	Limited
1280 × 720/24 <sup>1)</sup> /P	4 : 2 : 2 (YCbCr) 10bit	Limited
1280 × 720/25/P	4 : 2 : 2 (YCbCr) 10bit	Limited
1280 × 720/30 <sup>1)</sup> /P	4 : 2 : 2 (YCbCr) 10bit	Limited

## HD-SDI Dual Link

Signal System	Signal Structure	Quantization
1920 × 1080/50/I	4 : 4 : 4 (YCbCr) 10bit	Limited
	4 : 4 : 4 (RGB) 10bit	Limited / Full
	4 : 4 : 4 (YCbCr) 12bit	Limited
	4 : 4 : 4 (RGB) 12bit	Limited / Full
1920 × 1080/60 <sup>1)</sup> /I	4 : 4 : 4 (YCbCr) 10bit	Limited
	4 : 4 : 4 (RGB) 10bit	Limited / Full
	4 : 4 : 4 (YCbCr) 12bit	Limited
	4 : 4 : 4 (RGB) 12bit	Limited / Full
1920 × 1080/50/P	4 : 2 : 2 (YCbCr) 10bit	Limited
1920 × 1080/60 <sup>1)</sup> /P	4 : 2 : 2 (YCbCr) 10bit	Limited
	4 : 4 : 4 (YCbCr) 10bit	Limited
	4 : 4 : 4 (RGB) 10bit	Limited / Full
	4 : 4 : 4 (YCbCr) 12bit	Limited
1920 × 1080/24 <sup>1)</sup> /PsF	4 : 4 : 4 (RGB) 12bit	Limited / Full
	4 : 4 : 4 (YCbCr) 12bit	Limited
	4 : 4 : 4 (RGB) 12bit	Limited / Full
	4 : 4 : 4 (YCbCr) 10bit	Limited
1920 × 1080/24 <sup>1)</sup> /P	4 : 4 : 4 (RGB) 10bit	Limited / Full
	4 : 4 : 4 (YCbCr) 12bit	Limited
	4 : 4 : 4 (RGB) 12bit	Limited / Full
	4 : 4 : 4 (YCbCr) 10bit	Limited
1920 × 1080/25/PsF	4 : 4 : 4 (RGB) 10bit	Limited / Full
	4 : 4 : 4 (YCbCr) 12bit	Limited
	4 : 4 : 4 (RGB) 12bit	Limited / Full
	4 : 4 : 4 (YCbCr) 10bit	Limited
1920 × 1080/25/P	4 : 4 : 4 (RGB) 10bit	Limited / Full
	4 : 4 : 4 (YCbCr) 12bit	Limited
	4 : 4 : 4 (RGB) 12bit	Limited / Full
	4 : 4 : 4 (YCbCr) 10bit	Limited

Signal System	Signal Structure	Quantization
1920 × 1080/30 <sup>1)</sup> /PsF	4 : 4 : 4 (YCbCr) 10bit	Limited
	4 : 4 : 4 (RGB) 10bit	Limited / Full
	4 : 4 : 4 (YCbCr) 12bit	Limited
	4 : 4 : 4 (RGB) 12bit	Limited / Full
1920 × 1080/30 <sup>1)</sup> /P	4 : 4 : 4 (YCbCr) 10bit	Limited
	4 : 4 : 4 (RGB) 10bit	Limited / Full
	4 : 4 : 4 (YCbCr) 12bit	Limited
	4 : 4 : 4 (RGB) 12bit	Limited / Full

### 3G-SDI

Signal System	Signal Structure	Quantization
1920 × 1080/50/I	4 : 4 : 4 (YCbCr) 10bit	Limited
	4 : 4 : 4 (RGB) 10bit	Limited / Full
	4 : 4 : 4 (YCbCr) 12bit	Limited
	4 : 4 : 4 (RGB) 12bit	Limited / Full
1920 × 1080/60 <sup>1)</sup> /I	4 : 4 : 4 (YCbCr) 10bit	Limited
	4 : 4 : 4 (RGB) 10bit	Limited / Full
	4 : 4 : 4 (YCbCr) 12bit	Limited
	4 : 4 : 4 (RGB) 12bit	Limited / Full
1280 × 720/50/P	4 : 4 : 4 (YCbCr) 10bit	Limited
	4 : 4 : 4 (RGB) 10bit	Limited / Full
1280 × 720/60 <sup>1)</sup> /P	4 : 4 : 4 (YCbCr) 10bit	Limited
	4 : 4 : 4 (RGB) 10bit	Limited / Full
1920 × 1080/50/P	4 : 2 : 2 (YCbCr) 10bit	Limited
1920 × 1080/60 <sup>1)</sup> /P	4 : 2 : 2 (YCbCr) 10bit	Limited
1920 × 1080/24 <sup>1)</sup> /PsF	4 : 4 : 4 (YCbCr) 10bit	Limited
	4 : 4 : 4 (RGB) 10bit	Limited / Full
	4 : 4 : 4 (YCbCr) 12bit	Limited
	4 : 4 : 4 (RGB) 12bit	Limited / Full
1920 × 1080/24 <sup>1)</sup> /P	4 : 4 : 4 (YCbCr) 10bit	Limited
	4 : 4 : 4 (RGB) 10bit	Limited / Full
	4 : 4 : 4 (YCbCr) 12bit	Limited
	4 : 4 : 4 (RGB) 12bit	Limited / Full
1920 × 1080/25/PsF	4 : 4 : 4 (YCbCr) 10bit	Limited
	4 : 4 : 4 (RGB) 10bit	Limited / Full
	4 : 4 : 4 (YCbCr) 12bit	Limited
	4 : 4 : 4 (RGB) 12bit	Limited / Full
1920 × 1080/25/P	4 : 4 : 4 (YCbCr) 10bit	Limited
	4 : 4 : 4 (RGB) 10bit	Limited / Full
	4 : 4 : 4 (YCbCr) 12bit	Limited
	4 : 4 : 4 (RGB) 12bit	Limited / Full
1920 × 1080/30 <sup>1)</sup> /PsF	4 : 4 : 4 (YCbCr) 10bit	Limited
	4 : 4 : 4 (RGB) 10bit	Limited / Full
	4 : 4 : 4 (YCbCr) 12bit	Limited
	4 : 4 : 4 (RGB) 12bit	Limited / Full

Signal System	Signal Structure	Quantization
1920 × 1080/30 <sup>1)</sup> /P	4 : 4 : 4 (YCbCr) 10bit	Limited
	4 : 4 : 4 (RGB) 10bit	Limited / Full
	4 : 4 : 4 (YCbCr) 12bit	Limited
	4 : 4 : 4 (RGB) 12bit	Limited / Full
1280 × 720/24 <sup>1)</sup> /P	4 : 4 : 4 (YCbCr) 10bit	Limited
	4 : 4 : 4 (RGB) 10bit	Limited / Full
1280 × 720/25/P	4 : 4 : 4 (YCbCr) 10bit	Limited
	4 : 4 : 4 (RGB) 10bit	Limited / Full
1280 × 720/30 <sup>1)</sup> /P	4 : 4 : 4 (YCbCr) 10bit	Limited
	4 : 4 : 4 (RGB) 10bit	Limited / Full

### HD-SDI Single Link (2K)

Signal System	Signal Structure	Quantization
2048 × 1080/24 <sup>1)</sup> /PsF	4 : 2 : 2 (YCbCr) 10bit	Limited
2048 × 1080/24 <sup>1)</sup> /P	4 : 2 : 2 (YCbCr) 10bit	Limited
2048 × 1080/25/PsF	4 : 2 : 2 (YCbCr) 10bit	Limited
2048 × 1080/25/P	4 : 2 : 2 (YCbCr) 10bit	Limited
2048 × 1080/30 <sup>1)</sup> /PsF	4 : 2 : 2 (YCbCr) 10bit	Limited
2048 × 1080/30 <sup>1)</sup> /P	4 : 2 : 2 (YCbCr) 10bit	Limited

### HD-SDI Dual Link (2K)

Signal System	Signal Structure	Quantization
2048 × 1080/24 <sup>1)</sup> /PsF	4 : 4 : 4 (XYZ) 12bit	Full
	4 : 4 : 4 (RGB) 10bit	Limited / Full
	4 : 4 : 4 (RGB) 12bit	Limited / Full
2048 × 1080/24 <sup>1)</sup> /P	4 : 4 : 4 (XYZ) 12bit	Full
	4 : 4 : 4 (RGB) 10bit	Limited / Full
	4 : 4 : 4 (RGB) 12bit	Limited / Full
2048 × 1080/25/PsF	4 : 4 : 4 (XYZ) 12bit	Full
	4 : 4 : 4 (RGB) 10bit	Limited / Full
	4 : 4 : 4 (RGB) 12bit	Limited / Full
2048 × 1080/25/P	4 : 4 : 4 (XYZ) 12bit	Full
	4 : 4 : 4 (RGB) 10bit	Limited / Full
	4 : 4 : 4 (RGB) 12bit	Limited / Full
2048 × 1080/30 <sup>1)</sup> /PsF	4 : 4 : 4 (XYZ) 12bit	Full
	4 : 4 : 4 (RGB) 10bit	Limited / Full
	4 : 4 : 4 (RGB) 12bit	Limited / Full
2048 × 1080/30 <sup>1)</sup> /P	4 : 4 : 4 (XYZ) 12bit	Full
	4 : 4 : 4 (RGB) 10bit	Limited / Full
	4 : 4 : 4 (RGB) 12bit	Limited / Full

### 3G-SDI Single Link (2K)

Signal System	Signal Structure	Quantization
2048 × 1080/24 <sup>1)</sup> /PsF	4 : 4 : 4 (XYZ) 12bit	Full
	4 : 4 : 4 (RGB) 10bit	Limited / Full
	4 : 4 : 4 (RGB) 12bit	Limited / Full
2048 × 1080/24 <sup>1)</sup> /P	4 : 4 : 4 (XYZ) 12bit	Full
	4 : 4 : 4 (RGB) 10bit	Limited / Full
	4 : 4 : 4 (RGB) 12bit	Limited / Full
2048 × 1080/25/PsF	4 : 4 : 4 (XYZ) 12bit	Full
	4 : 4 : 4 (RGB) 10bit	Limited / Full
	4 : 4 : 4 (RGB) 12bit	Limited / Full
2048 × 1080/25/P	4 : 4 : 4 (XYZ) 12bit	Full
	4 : 4 : 4 (RGB) 10bit	Limited / Full
	4 : 4 : 4 (RGB) 12bit	Limited / Full
2048 × 1080/30 <sup>1)</sup> /PsF	4 : 4 : 4 (XYZ) 12bit	Full
	4 : 4 : 4 (RGB) 10bit	Limited / Full
	4 : 4 : 4 (RGB) 12bit	Limited / Full
2048 × 1080/30 <sup>1)</sup> /P	4 : 4 : 4 (XYZ) 12bit	Full
	4 : 4 : 4 (RGB) 10bit	Limited / Full
	4 : 4 : 4 (RGB) 12bit	Limited / Full

### HDMI

Signal System	Quantization
640 × 480/60 <sup>1)</sup> /P	Full
720 × 480/60 <sup>1)</sup> /P	Limited
1280 × 720/60 <sup>1)</sup> /P	Limited
1920 × 1080/60 <sup>1)</sup> /I	Limited
720 × 480/60 <sup>1)</sup> /I	Limited
720 × 576/50/P	Limited
1280 × 720/50/P	Limited
1920 × 1080/50/I	Limited
720 × 576/50/I	Limited
1920 × 1080/60 <sup>1)</sup> /P	Limited
1920 × 1080/50/P	Limited
1920 × 1080/24 <sup>1)</sup> /P	Limited
1920 × 1080/25/P	Limited
1920 × 1080/30 <sup>1)</sup> /P	Limited
2048 × 1080/24 <sup>1)</sup> /P	Limited
2048 × 1080/25/P	Limited
2048 × 1080/30 <sup>1)</sup> /P	Limited
2048 × 1080/60 <sup>1)</sup> /P	Limited
2048 × 1080/50/P	Limited
2048 × 1080/48/P	Limited
800 × 600/60/P	Full
1024 × 768/60/P	Full

Signal System	Quantization
1280 × 960/60/P	Full
1280 × 1024/60/P	Full
1400 × 1050/60/P	Full

1) Also compatible with the frame rate 1/1.001.

2) Displayed as masked when blanking SMPTE ST170 (480/59.94i) and ITU-R BT.470 (576/50i) horizontally.

## Aperture Modification Frequency

### SDI/composite input

Signal system	Serial digital input		Analog input	HDMI input
	SD-SDI	3G/HD-SDI	Composite	Component (YCbCr) RGB
576/50i	5 MHz		5 MHz	
487/59.94i	5 MHz		5 MHz	
1080/24 <sup>1)</sup> PsF		25 MHz		
1080/24 <sup>1)</sup> P		25 MHz		
1080/50i (25PsF)		25 MHz		
1080/25P		25 MHz		
1080/60 <sup>1)</sup> i (30 <sup>1)</sup> PsF)		25 MHz		
1080/30 <sup>1)</sup> P		25 MHz		
720/24 <sup>1)</sup> P		25 MHz		
720/25P		25 MHz		
720/30 <sup>1)</sup> P		25 MHz		
720/50P		25 MHz		
720/60 <sup>1)</sup> P		25 MHz		
2048 × 1080/24 <sup>1)</sup> PsF		25 MHz		
2048 × 1080/24 <sup>1)</sup> P		25 MHz		
2048 × 1080/25PsF		25 MHz		
2048 × 1080/25P		25 MHz		
2048 × 1080/30 <sup>1)</sup> PsF		25 MHz		
2048 × 1080/30 <sup>1)</sup> P		25 MHz		
1080/50P		50 MHz		
1080/60 <sup>1)</sup> P		50 MHz		

### HDMI

Signal system	Serial digital input		Analog input	HDMI input
	SD-SDI	3G/HD-SDI	Composite	Component (YCbCr) RGB
640 × 480/60 <sup>1)</sup> P				10 MHz
720 × 480/60 <sup>1)</sup> P				10 MHz
1280 × 720/60 <sup>1)</sup> P				25 MHz
1920 × 1080/60 <sup>1)</sup> i				25 MHz
720 (1440) <sup>2)</sup> × 480/60 <sup>1)</sup> i				5 MHz
720 × 576/50P				10 MHz
1280 × 720/50P				25 MHz

Signal system	Serial digital input		Analog input	HDMI input
	SD-SDI	3G/HD-SDI	Composite	Component (YCbCr) RGB
1920 × 1080/50i				25 MHz
720 (1440) <sup>2)</sup> × 576/50i				5 MHz
1920 × 1080/60 <sup>1)</sup> P				50 MHz
1920 × 1080/50P				50 MHz
1920 × 1080/24 <sup>1)</sup> P				25 MHz
1920 × 1080/25P				25 MHz
1920 × 1080/30 <sup>1)</sup> P				25 MHz
2048 × 1080/24 <sup>1)</sup> P				25 MHz
2048 × 1080/25P				25 MHz
2048 × 1080/30 <sup>1)</sup> P				25 MHz
2048 × 1080/60 <sup>1)</sup> P				50 MHz
2048 × 1080/50P				50 MHz
2048 × 1080/48 <sup>1)</sup> P				50 MHz

1) Also compatible with the frame rate 1/1.001.

2) Pixel Repetition = 2 (transmit the same pixel twice)

Blank column: The signal cannot be input or the aperture modification does not operate for that signal even if it is input.

## Picture Display Size

### SDI/composite input

Signal system	Aspect ratio	Native Scan ×1	Native Scan ×2	Native Scan Aspect Correction	Normal Scan	Under Scan	Over Scan	Side by Side
		(H) × (V)	(H) × (V)	(H) × (V)	(H) × (V)	(H) × (V)	(H) × (V)	(H) × (V)
720 <sup>2)</sup> × 576/50i	4:3	720 × 576	1440 × 1152	1575 × 1152	1477 × 1080	1432 × 1048	1407 × 1029	960 × 702
	16:9			2100 × 1152	1920 × 1053	1862 × 1022	1829 × 1003	960 × 527
720 <sup>2)</sup> × 487/59.94i	4:3	720 × 487	1440 × 974	1302 × 974	1443 × 1080	1400 × 1048	1374 × 1029	960 × 718
	16:9			1736 × 974	1920 × 1077	1862 × 1045	1829 × 1026	960 × 539
1920 × 1080/24 <sup>1)</sup> PsF	16:9	1920 × 1080			1920 × 1080	1862 × 1048	1829 × 1029	960 × 540
	2.39:1				1920 × 803	1862 × 779	1829 × 765	960 × 402
1920 × 1080/25PsF	16:9	1920 × 1080			1920 × 1080	1862 × 1048	1829 × 1029	960 × 540
	2.39:1				1920 × 803	1862 × 779	1829 × 765	960 × 402
1920 × 1080/30 <sup>1)</sup> PsF	16:9	1920 × 1080			1920 × 1080	1862 × 1048	1829 × 1029	960 × 540
	2.39:1				1920 × 803	1862 × 779	1829 × 765	960 × 402
1920 × 1080/24 <sup>1)</sup> P	16:9	1920 × 1080			1920 × 1080	1862 × 1048	1829 × 1029	960 × 540
	2.39:1				1920 × 803	1862 × 779	1829 × 765	960 × 402
1920 × 1080/25P	16:9	1920 × 1080			1920 × 1080	1862 × 1048	1829 × 1029	960 × 540
	2.39:1				1920 × 803	1862 × 779	1829 × 765	960 × 402
1920 × 1080/30 <sup>1)</sup> P	16:9	1920 × 1080			1920 × 1080	1862 × 1048	1829 × 1029	960 × 540
	2.39:1				1920 × 803	1862 × 779	1829 × 765	960 × 402
1920 × 1080/50i	16:9	1920 × 1080			1920 × 1080	1862 × 1048	1829 × 1029	960 × 540
	2.39:1				1920 × 803	1862 × 779	1829 × 765	960 × 402
1920 × 1080/60 <sup>1)</sup> i	16:9	1920 × 1080			1920 × 1080	1862 × 1048	1829 × 1029	960 × 540
	2.39:1				1920 × 803	1862 × 779	1829 × 765	960 × 402

Signal system	Aspect ratio	Native Scan ×1	Native Scan ×2	Native Scan Aspect Correction	Normal Scan	Under Scan	Over Scan	Side by Side
		(H) × (V)	(H) × (V)	(H) × (V)	(H) × (V)	(H) × (V)	(H) × (V)	(H) × (V)
1920 × 1080/50P	16:9	1920 × 1080			1920 × 1080	1862 × 1048	1829 × 1029	960 × 540
	2.39:1				1920 × 803	1862 × 779	1829 × 765	960 × 402
1920 × 1080/60 <sup>1)</sup> P	16:9	1920 × 1080			1920 × 1080	1862 × 1048	1829 × 1029	960 × 540
	2.39:1				1920 × 803	1862 × 779	1829 × 765	960 × 402
1280 × 720/24 <sup>1)</sup> P	16:9	1280 × 720			1920 × 1080	1862 × 1048	1829 × 1029	960 × 540
1280 × 720/25P	16:9	1280 × 720			1920 × 1080	1862 × 1048	1829 × 1029	960 × 540
1280 × 720/30 <sup>1)</sup> P	16:9	1280 × 720			1920 × 1080	1862 × 1048	1829 × 1029	960 × 540
1280 × 720/50P	16:9	1280 × 720			1920 × 1080	1862 × 1048	1829 × 1029	960 × 540
1280 × 720/60 <sup>1)</sup> P	16:9	1280 × 720			1920 × 1080	1862 × 1048	1829 × 1029	960 × 540
2048 × 1080/24 <sup>1)</sup> PsF	1.896:1	2048 × 1080			1920 × 1013	1862 × 982	1829 × 965	960 × 506
	2.39:1				1920 × 803	1862 × 779	1829 × 765	960 × 402
2048 × 1080/24 <sup>1)</sup> P	1.896:1	2048 × 1080			1920 × 1013	1862 × 982	1829 × 965	960 × 506
	2.39:1				1920 × 803	1862 × 779	1829 × 765	960 × 402
2048 × 1080/25PsF	1.896:1	2048 × 1080			1920 × 1013	1862 × 982	1829 × 965	960 × 506
	2.39:1				1920 × 803	1862 × 779	1829 × 765	960 × 402
2048 × 1080/25P	1.896:1	2048 × 1080			1920 × 1013	1862 × 982	1829 × 965	960 × 506
	2.39:1				1920 × 803	1862 × 779	1829 × 765	960 × 402
2048 × 1080/30 <sup>1)</sup> PsF	1.896:1	2048 × 1080			1920 × 1013	1862 × 982	1829 × 965	960 × 506
	2.39:1				1920 × 803	1862 × 779	1829 × 765	960 × 402
2048 × 1080/30 <sup>1)</sup> P	1.896:1	2048 × 1080			1920 × 1013	1862 × 982	1829 × 965	960 × 506
	2.39:1				1920 × 803	1862 × 779	1829 × 765	960 × 402

1) Also compatible with the frame rate 1/1.001.

2) For composite signals, displayed as masked when blanking SMPTE ST170 (480/59.94i) and ITU-R BT.470 (576/50i) horizontally.

- Over Scan: The area size where 5% over scan portion in the normal scan is masked.
- Native Scan Aspect Correction: The area over the H size (1920) is not displayed.

## HDMI

Signal system	Aspect ratio	Native Scan ×1	Native Scan ×2	Native Scan Aspect Correction	Normal Scan	Under Scan	Over Scan	Side by Side
		(H) × (V)	(H) × (V)	(H) × (V)	(H) × (V)	(H) × (V)	(H) × (V)	(H) × (V)
640 × 480/60 <sup>1)</sup> P	4:3	640 × 480	1280 × 960	1280 × 960	1440 × 1080	1397 × 1048	1371 × 1029	960 × 720
720 × 480/60 <sup>1)</sup> P	4:3	720 × 480	1440 × 960	1280 × 960	1440 × 1080	1397 × 1048	1371 × 1029	960 × 720
	16:9			1707 × 960	1920 × 1080	1862 × 1048	1829 × 1029	960 × 540
1280 × 720/60 <sup>1)</sup> P	16:9	1280 × 720			1920 × 1080	1862 × 1048	1829 × 1029	960 × 540
1920 × 1080/60 <sup>1)</sup> i	16:9	1920 × 1080			1920 × 1080	1862 × 1048	1829 × 1029	960 × 540
	2.39:1				1920 × 803	1862 × 779	1829 × 765	960 × 402
720 (1440) <sup>2)</sup> × 480/60 <sup>1)</sup> i	4:3	720 × 480	1440 × 960	1280 × 960	1440 × 1080	1397 × 1048	1371 × 1029	960 × 720
	16:9			1707 × 960	1920 × 1080	1862 × 1048	1829 × 1029	960 × 540
720 × 576/50P	4:3	720 × 576	1440 × 1152	1536 × 1152	1440 × 1080	1397 × 1048	1371 × 1029	960 × 720
	16:9			2048 × 1152	1920 × 1080	1862 × 1048	1829 × 1029	960 × 540
1280 × 720/50P	16:9	1280 × 720			1920 × 1080	1862 × 1048	1829 × 1029	960 × 540

Signal system	Aspect ratio	Native Scan ×1	Native Scan ×2	Native Scan Aspect Correction	Normal Scan	Under Scan	Over Scan	Side by Side
		(H) × (V)	(H) × (V)	(H) × (V)	(H) × (V)	(H) × (V)	(H) × (V)	(H) × (V)
1920 × 1080/50i	16:9	1920 × 1080			1920 × 1080	1862 × 1048	1829 × 1029	960 × 540
	2.39:1				1920 × 803	1862 × 779	1829 × 765	960 × 402
720 (1440) <sup>2</sup> × 576/50i	4:3	720 × 576	1440 × 1152	1536 × 1152	1440 × 1080	1397 × 1048	1371 × 1029	960 × 720
	16:9			2048 × 1152	1920 × 1080	1862 × 1048	1829 × 1029	960 × 540
1920 × 1080/60 <sup>1</sup> P	16:9	1920 × 1080			1920 × 1080	1862 × 1048	1829 × 1029	960 × 540
	2.39:1				1920 × 803	1862 × 779	1829 × 765	960 × 402
1920 × 1080/50P	16:9	1920 × 1080			1920 × 1080	1862 × 1048	1829 × 1029	960 × 540
	2.39:1				1920 × 803	1862 × 779	1829 × 765	960 × 402
1920 × 1080/24 <sup>1</sup> P	16:9	1920 × 1080			1920 × 1080	1862 × 1048	1829 × 1029	960 × 540
	2.39:1				1920 × 803	1862 × 779	1829 × 765	960 × 402
1920 × 1080/25P	16:9	1920 × 1080			1920 × 1080	1862 × 1048	1829 × 1029	960 × 540
	2.39:1				1920 × 803	1862 × 779	1829 × 765	960 × 402
1920 × 1080/30 <sup>1</sup> P	16:9	1920 × 1080			1920 × 1080	1862 × 1048	1829 × 1029	960 × 540
	2.39:1				1920 × 803	1862 × 779	1829 × 765	960 × 402
2048 × 1080/24 <sup>1</sup> P	1.896:1	2048 × 1080			1920 × 1013	1862 × 982	1829 × 965	960 × 506
	2.39:1				1920 × 803	1862 × 779	1829 × 765	960 × 402
2048 × 1080/25P	1.896:1	2048 × 1080			1920 × 1013	1862 × 982	1829 × 965	960 × 506
	2.39:1				1920 × 803	1862 × 779	1829 × 765	960 × 402
2048 × 1080/30 <sup>1</sup> P	1.896:1	2048 × 1080			1920 × 1013	1862 × 982	1829 × 965	960 × 506
	2.39:1				1920 × 803	1862 × 779	1829 × 765	960 × 402
2048 × 1080/60 <sup>1</sup> P	1.896:1	2048 × 1080			1920 × 1013	1862 × 982	1829 × 965	960 × 506
	2.39:1				1920 × 803	1862 × 779	1829 × 765	960 × 402
2048 × 1080/50P	1.896:1	2048 × 1080			1920 × 1013	1862 × 982	1829 × 965	960 × 506
	2.39:1				1920 × 803	1862 × 779	1829 × 765	960 × 402
2048 × 1080/48 <sup>1</sup> P	1.896:1	2048 × 1080			1920 × 1013	1862 × 982	1829 × 965	960 × 506
	2.39:1				1920 × 803	1862 × 779	1829 × 765	960 × 402
800 × 600/60P (SVGA)	4:3	800 × 600						960 × 720
1024 × 768/60P (XGA)	4:3	1024 × 768						960 × 720
1280 × 960/60P (SXGA)	4:3	1280 × 960						960 × 720
1280 × 1024/60P (SXGA)	5:4	1280 × 1024						960 × 768
1400 × 1050/60P (SXGA+)	4:3	1400 × 1050						960 × 720

1) Also compatible with 1/1.001

2) Pixel Repetition = 2 (transmit the same pixel twice)

- **Over Scan:** The area size where 5% over scan portion in the normal scan is masked.
- **Native Scan Aspect Correction:** The area over the H size (1920) is not displayed.
- The aspect ratio is manually set when the [HDMI Auto] menu (page 38) of the [Screen Aspect] menu is set to [Off].



# Picture Frame Display

## SDI/composite input

Signal system	Progressive	Interlace
	Display frame rate [Hz]	Display frame rate [Hz]
720 × 576/50i	50	50
720 × 487/59.94i	59.94	59.94
1920 × 1080/24 <sup>1)</sup> PsF	48 <sup>1)</sup>	48 <sup>1) 2)</sup>
1920 × 1080/25PsF	50	50 <sup>2)</sup>
1920 × 1080/30 <sup>1)</sup> PsF	60 <sup>1)</sup>	60 <sup>1) 2)</sup>
1920 × 1080/24 <sup>1)</sup> P	48 <sup>1)</sup>	×
1920 × 1080/25P	50	×
1920 × 1080/30 <sup>1)</sup> P	60 <sup>1)</sup>	×
1920 × 1080/50i	50	50 <sup>3)</sup>
1920 × 1080/60 <sup>1)</sup> i	60 <sup>1)</sup>	60 <sup>1) 3)</sup>
1920 × 1080/50P	50	×
1920 × 1080/60 <sup>1)</sup> P	60 <sup>1)</sup>	×
1280 × 720/24 <sup>1)</sup> P	50	×
1280 × 720/25P	50	×
1280 × 720/30 <sup>1)</sup> P	50	×
1280 × 720/50P	50	×
1280 × 720/60 <sup>1)</sup> P	60 <sup>1)</sup>	×
2048 × 1080/24 <sup>1)</sup> PsF	48 <sup>1)</sup>	48 <sup>1) 2)</sup>
2048 × 1080/25PsF	50	50 <sup>2)</sup>
2048 × 1080/30 <sup>1)</sup> PsF	60 <sup>1)</sup>	60 <sup>1) 2)</sup>
2048 × 1080/24 <sup>1)</sup> P	48 <sup>1)</sup>	×
2048 × 1080/25P	50	×
2048 × 1080/30 <sup>1)</sup> P	60 <sup>1)</sup>	×

1) Also compatible with 1/1.001.

2) When [1080I] is selected in the [1080I/PsF] menu of the [Channel Configuration] menu, the input signal is

regarded as an interlace signal, and it can be displayed in interlace mode if the interlace display mode is selected.

3) Functions when [1080I] is selected in the [1080I/PsF] menu of the [Channel Configuration] menu.

## HDMI

Signal system	Progressive	Interlace
	Display frame rate [Hz]	Display frame rate [Hz]
640 × 480/60 <sup>1)</sup> P	60 <sup>1)</sup>	×
720 × 480/60 <sup>1)</sup> P	60 <sup>1)</sup>	×
1280 × 720/60 <sup>1)</sup> P	60 <sup>1)</sup>	×
1920 × 1080/60 <sup>1)</sup> i	60 <sup>1)</sup>	60 <sup>1)</sup>
720 (1440) <sup>2)</sup> × 480/60 <sup>1)</sup> i	60 <sup>1)</sup>	60 <sup>1)</sup>
720 × 576/50P	50	×
1280 × 720/50P	50	×
1920 × 1080/50i	50	50
720 (1440) <sup>2)</sup> × 576/50i	50	50
1920 × 1080/60 <sup>1)</sup> P	60 <sup>1)</sup>	×

Signal system	Progressive	Interlace
	Display frame rate [Hz]	Display frame rate [Hz]
1920 × 1080/50P	50	×
1920 × 1080/24 <sup>1)</sup> P	48 <sup>1)</sup>	×
1920 × 1080/25P	50	×
1920 × 1080/30 <sup>1)</sup> P	60 <sup>1)</sup>	×
2048 × 1080/24 <sup>1)</sup> P	48 <sup>1)</sup>	×
2048 × 1080/25P	50	×
2048 × 1080/30 <sup>1)</sup> P	60 <sup>1)</sup>	×
2048 × 1080/60 <sup>1)</sup> P	60 <sup>1)</sup>	×
2048 × 1080/50P	50	×
2048 × 1080/48 <sup>1)</sup> P	48 <sup>1)</sup>	×
800 × 600/60P (SVGA)	60	×
1024 × 768/60P (XGA)	60	×
1280 × 960/60P (SXGA)	60	×
1280 × 1024/60P (SXGA)	60	×
1400 × 1050/60P (SXGA+)	60	×

1) Also compatible with 1/1.001.

2) Pixel Repetition = 2 (transmit the same pixel twice)

# Scan Mode Image

**Example: Scan images of available signal systems when a signal is input from the SDI input or composite input**

- For details of the picture display size, see “Picture Display Size” (page 86).
- For setting of the [Native Scan Mode] menu, see [Native Scan Mode] (page 42) of the [Auxiliary Setting] menu.
- For setting Aspect, see the [Screen Aspect] menu (page 38) of the [Channel Configuration] menu.

## Panel size



## [Native Scan]

Scan mode	Input signal system and scan mode image
[Native Scan Mode]: [×1]	<p>1920 × 1080</p> <p>2048 × 1080</p> <p>Displayed by sliding the picture with the PHASE knob of the controller.</p>
	<p>1280 × 720</p>
	<p>720 × 576 720 × 487</p>
[Native Scan Mode]: [×2]	<p>720 × 487</p>

Scan mode	Input signal system and scan mode image
	<p>720 × 576</p> <p>Displayed by sliding the picture with the UP/DOWN button of the controller.</p>
[Native Scan Mode]: [Aspect Correction] Aspect: [4:3]	<p>720 × 487</p>
	<p>720 × 576</p>
[Native Scan Mode]: [Aspect Correction] Aspect: [16:9]	<p>720 × 487</p>
	<p>720 × 576</p> <p>Displayed the whole picture of the V direction by sliding the picture with the UP/DOWN button of the controller.</p> <p>Displayed the whole picture of the H direction by sliding the picture with the PHASE knob of the controller.</p>
[Normal Scan]	
Scan mode	Input signal system and scan mode image
Aspect: [16:9] ([1.896:1] <sup>1)</sup> )	<p>1920 × 1080 1280 × 720 2048 × 1080 720 × 576 720 × 487</p>
Aspect: [2.39:1]	<p>1920 × 1080 2048 × 1080</p>
Aspect: [4:3]	<p>720 × 576 720 × 487</p>

1) When a 2048 × 1080 signal is input

## [Under Scan]

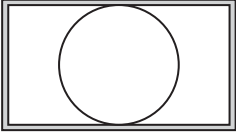
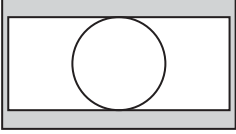
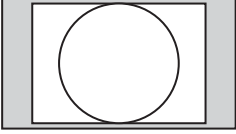
Scan mode	Input signal system and scan mode image
Aspect: [16:9] ([1.896:1] <sup>1)</sup> )	1920 × 1080 1280 × 720 2048 × 1080 720 × 576 720 × 487 
Aspect: [2.39:1]	1920 × 1080 2048 × 1080 
Aspect: [4:3]	720 × 576 720 × 487 

1) When a 2048 × 1080 signal is input

## [Over Scan]

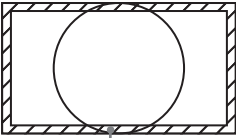
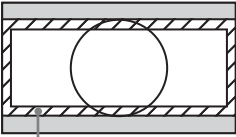
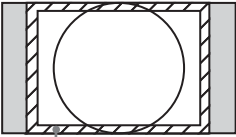
Scan mode	Input signal system and scan mode image
Aspect: [16:9] ([1.896:1] <sup>1)</sup> )	1920 × 1080 1280 × 720 2048 × 1080 720 × 576 720 × 487  <p>5% mask portion</p>
Aspect: [2.39:1]	2048 × 1080 1920 × 1080  <p>5% mask portion</p>
Aspect: [4:3]	720 × 576 720 × 487  <p>5% mask portion</p>

1) When a 2048 × 1080 signal is input

## Inserting/Ejecting the USB memory stick

The BKM-17R Monitor Control Unit has a USB connector.

Proceed as illustrated to insert and eject a USB memory stick (sold separately).

See each menu for information about operations on USB memory stick data.

### Note

Do not eject the USB memory stick while data is being saved or loaded.

### To insert and eject the USB memory stick

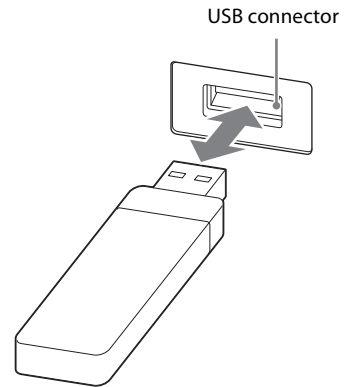

### Notes

- Make sure to insert the USB memory stick into the USB connector in the correct direction.
- When ejecting the USB memory stick, make sure that the unit is not accessing the USB memory stick.

### Notes on USB memory sticks

The USB 3.0 memory sticks up to 8 GB have been tested with this product.

### Note

This does not guarantee complete support of all USB memory sticks.

### Note on data read/write speed

Data read/write speed may vary depending on the combination of the USB memory stick and the product that you use.

### Notes

- Image data may be damaged in the following cases:
  - If you eject the USB memory stick, or turn the unit off while accessing the data
  - If you use a USB memory stick near static electricity or a magnetic field
- We recommend backing up important data.
- Do not touch the connector of the USB memory stick with anything, including your finger or metallic objects.
- Do not strike, bend, or drop the USB memory stick.

- Do not disassemble or modify the USB memory stick.
- Do not allow the USB memory stick to get wet.
- Do not use or store the USB memory stick in a location that is:
  - Extremely hot, such as in a car parked in the sun
  - Under direct sunlight
  - Very humid or subject to corrosive substances
- The USB connector of BKM-17R is compatible with USB memory sticks. Do not insert other devices than USB memory sticks, such as USB conversion adaptors.
- You cannot use any other devices than USB memory sticks with the USB connector of BKM-17R, such as USB hubs.
- Do not insert multiple USB memory sticks at the same time. This may cause damage to the product.
- When you use a USB memory stick with BKM-17R, be sure to insert it in the right direction. Inserting it in the wrong direction may cause damages to the product.
- The USB memory stick should be kept away from small children to prevent them from accidentally swallowing it.
- Up to 1000 files can be memorized in one USB memory stick. When more than 1000 files are created, the warning [Too many files] is displayed. Delete an unused file using [Delete] (page 51) in the [Capture] menu of the [Function Setting] menu, or the [Delete] menu (page 64) of the [File Management] menu, or using the machine and application corresponding to the USB memory stick.
- Up to 20 characters can be used for the file name. When more than 20 characters are used for the file name, the file is not displayed.
- The USB memory stick must be formatted with the FAT32 file system. If you insert the USB memory stick which has been formatted with another file system, a format error occurs and the USB memory stick is not usable for this unit.

It is against the copyright law to use any audio or picture you recorded without prior consent of the copyright holder. Accordingly, USB memory sticks with content protected image or data can be only used within the law.

# Dimensions

## BVM-E251

Unit: mm (inches)

### Front

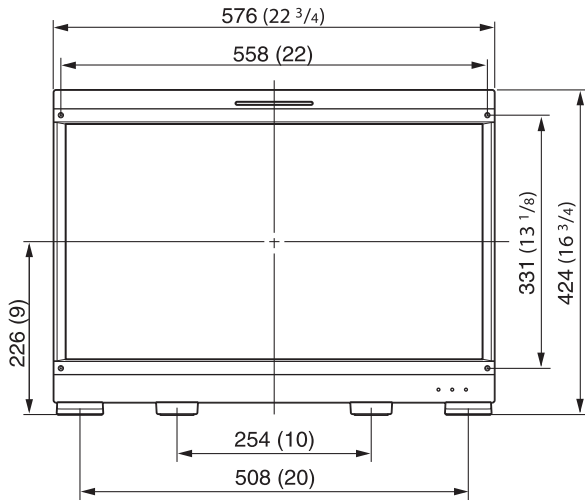

### Side

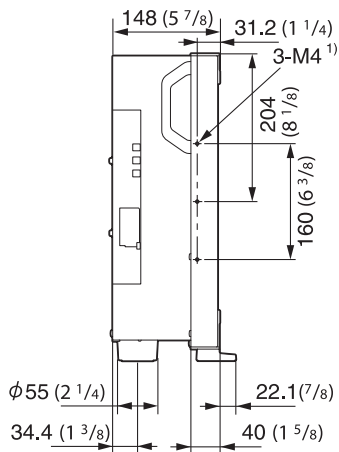

- 1) When using this hole, use a screw which can be inserted into the monitor to a depth of 6 to 8 mm ( $1/4$  to  $11/32$  inches).

### Rear

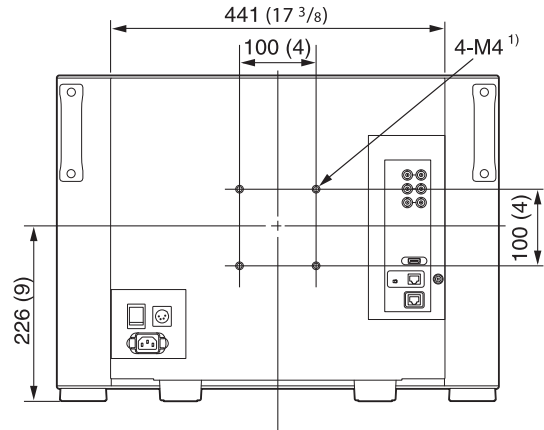

- 1) When using this hole, use a screw which can be inserted into the monitor to a depth of 6 to 8 mm ( $1/4$  to  $11/32$  inches).

### When the controller is attached with the BKM-37H

### When the tilt unit is removed from the BKM-37H

### Front

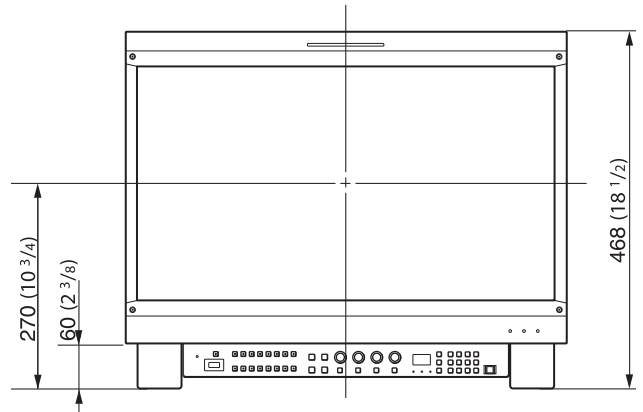

**Side**

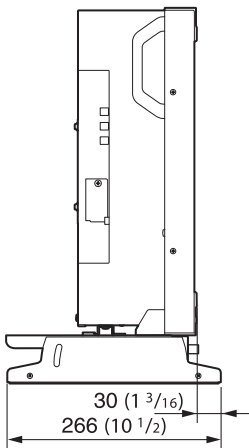

**Bottom**

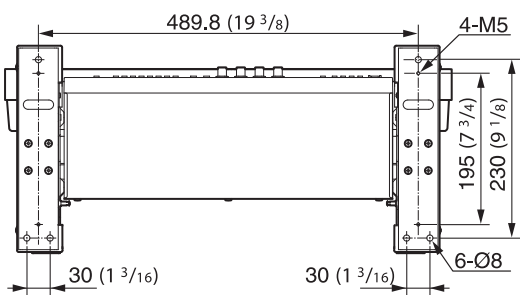

**When the tilt unit is attached to the BKM-37H**

**Front**

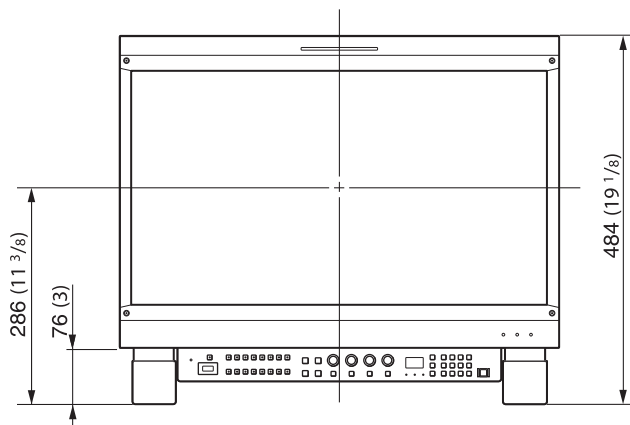

**Side**

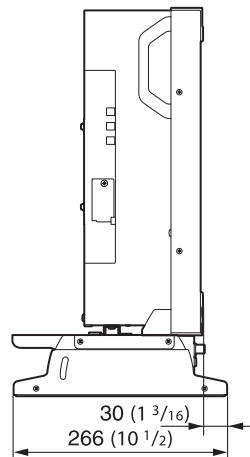

**Bottom**

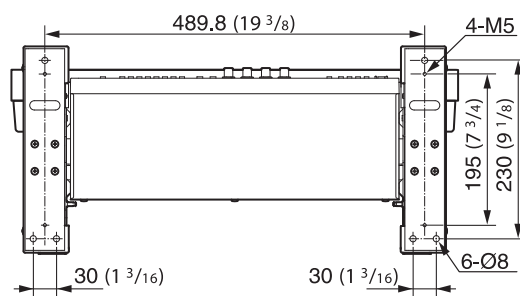

**When the controller is attached with the BKM-38H**

**Front**

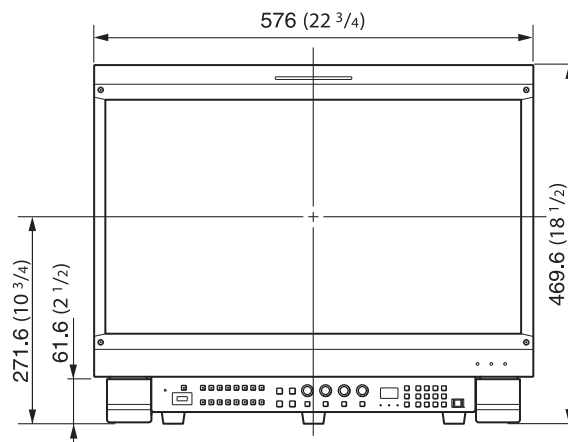

**Side**

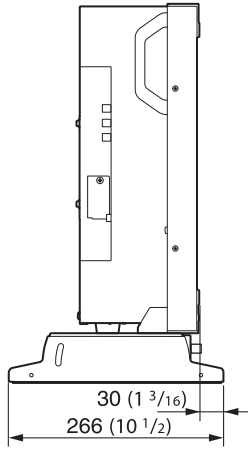

**Bottom**

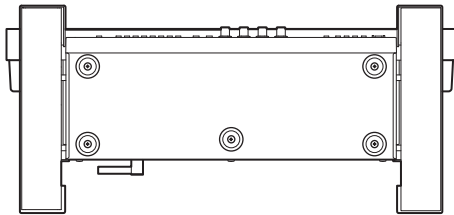

**BVM-E171**

Unit: mm (inches)

**Front**

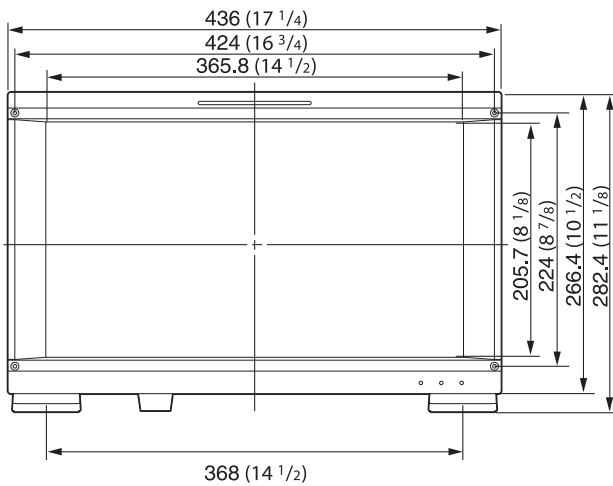

**Side**

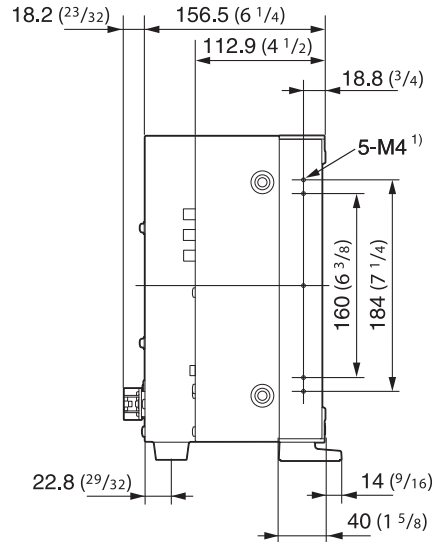

- 1) When using this hole, use a screw which can be inserted into the monitor to a depth of 6 to 8 mm (1/4 to 11/32 inches).

**Rear**

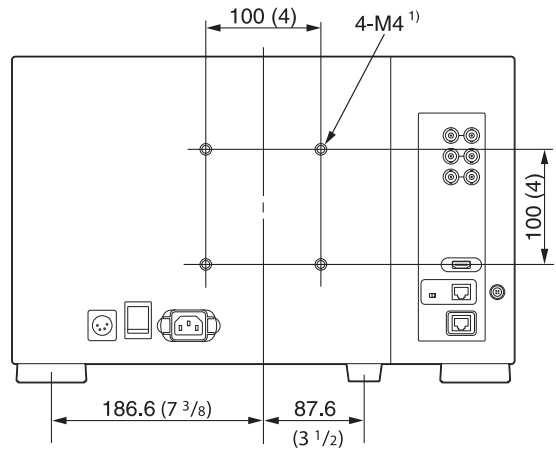

- 1) When using this hole, use a screw which can be inserted into the monitor to a depth of 6 to 8 mm (1/4 to 11/32 inches).



## When the controller is attached with the BKM-39H

### Front

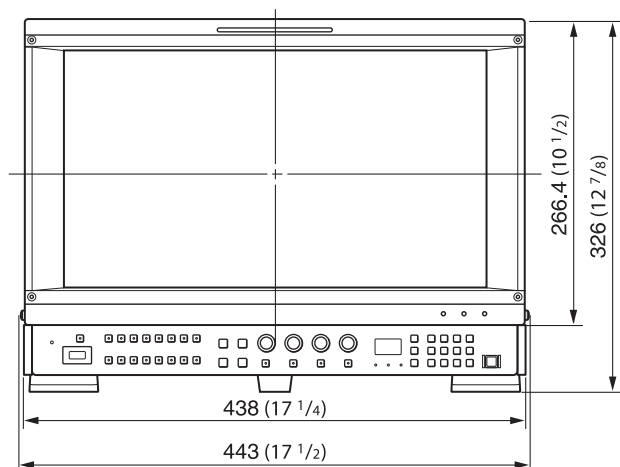

### Side

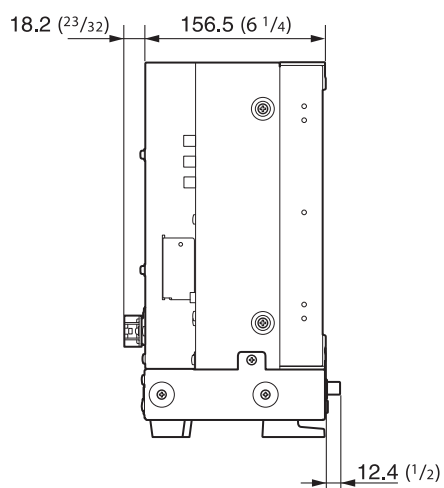

### Top

