

Display

Date: **May 16, 1994**

Subject: **UNRECOGNIZABLE SERIAL DIGITAL (D-1) AUTO SETUP FROM REMOTE CONTROL MODE**

Model: **BKM-2085-14, BKM-2085-20, BVM-1316C**

Serial No: **ALL**

DESCRIPTION

When serial digital (D-1) input is selected using remote control mode, the RGB/COMPONENT menu is displayed instead of the serial digital (D-1) Auto Setup menu. To correct this condition, perform the following modification procedure.

MODIFICATION PROCEDURE

BV2 Board (Component Side)
 (See Figures 1 and 2.)

1. Remove R22.
2. Solder jumper between R23 and Q22 collector.

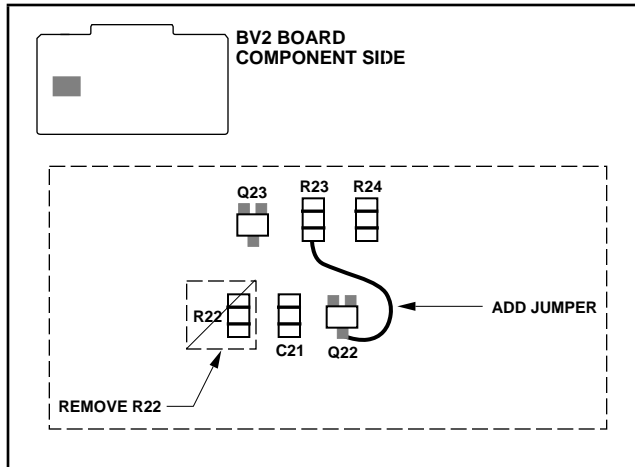

Figure 1

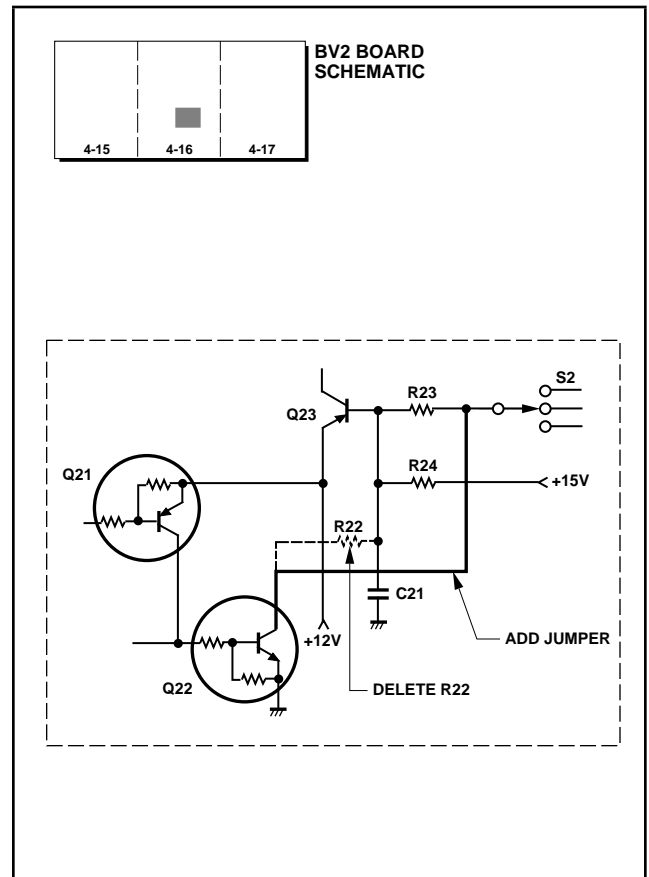

Figure 2