

1	Cover Page
2	GPIO Table & Voltage Rails
3	Pentium III BGA2 Part 1 of 4
4	Pentium III BGA2 Part 2 of 4
5	Pentium III BGA2 Parts 3 & 4
6	CPU VCORE & VTT Decoupling
7	NV2B part 1 of 2 (North Bridge)
8	NV2B Part 2 of 2 (North Bridge)
9	NV2B Strapping
10	NV2B & MCPX Decoupling
11	DDR SDRAM (Partition A)
12	DDR SDRAM (Partition B)
13	DDR SDRAM (Partition C)
14	DDR SDRAM (Partition D)
15	DDR Series Term. Data A & B
16	DDR Series Term. Data C & D
17	Memory Decoupling
18	Memory Decoupling
19	MCPX Part 1 of 2
20	MCPX Part 2 of 2

21	MCPX Input Straps
22	Voltage Regulator 1.5V
23	1.5V Output Filter & 3.3V Regulator
24	Xcalibur ASIC
25	Xcalibur Decoupling & Clocks
26	1.5VTT & 2.5V Regulators
27	Power Connector & 5V Drain
28	Bulk Decoupling
29	LAN ICS1893
30	LAN Jack, EEPROM, & Thermal Sensor
31	IDE
32	Audio Codec & Voltage Regulator
33	Audio Amplifier
34	Video Filtering & Miscellaneous
35	AV Connector
36	Labels & Mounting Holes
37	USB Front Panel
38	Fan, DVD Power, & Front Panel
39	Xyclops ASIC
40	Supercap

Notes:

1. This schematic documents the generic product with all possible configurations. Please refer to specific product PBA EPLs for items shown as optional in the schematic.
2. Resistors are in ohms unless otherwise specified.
3. VCC = +5V unless otherwise specified.
4. * suffix indicates active low signal.
5. \ suffix indicates signal exits hierarchical block.
6. This document also exists on electronic media.

DVT
Rev 5.1
Fab J/K
XM3

Tuscany
(Commonly known as 1.6)

Note: This schematic represents 4 different board versions listed below.

XM2 versions (-1X0) have notes beside components that change between versions. XM3 versions (-1X1) show production stuffing.

Fab J boards are the -12X boards (DVT1)
These have 2 footprints for the supercap

Fab L boards are the -13X boards (DVT3)
These have 1 footprint for the supercap

Pages with differences are: 19, 35, 40

7/15/22		
Initial release		
Remade in KiCad		
Microsoft		
Sheet: /		
File: Xbox Tuscany.kicad_sch		
Title: Tuscany Fab K		
Size: B	Date: 3/15/2004	Rev: 5.1
KiCad E.D.A. kicad (6.0.6)		Id: 1/40

GPIO USAGE TABLE

Device	Name	I/O	Power Well	During Reset	After Reset	Usage
MCPX	GPI00	OUT	VCC3	Z	Z	Testpoint (not used)
MCPX	GPI01	OUT	VCC3	H	Z	CNFG_SEL1
MCPX	GPI014	IN	VCC3	Z	Z	CNFG_SEL0
MCPX	GPI015	OUT	VCC3	Z	Z	TP_DEBUG_GPI015
MCPX	GPI016	IN	VCC3	Z	Z	CNFG_SEL2
MCPX	GPI019	OUT	VCC3	Z	Z	LVLCNT1
MCPX	GPI020	OUT	VCC3	Z	Z	Testpoint (not used)
MCPX	GPI021	IN	VCC3	H	H	SMI* input from SMC
MCPX	GPI022	OUT	VCC3	Z	Z	LVLCNT0
MCPX	GPI024	OUT	VCC3	Z	Z	Testpoint (not used)

Device	Name	I/O	Power Well	During Reset	After Reset	Usage
XCAL	GPI00	I/O	?	?	?	UNUSED
XCAL	GPI01	I/O	?	?	?	UNUSED
XCAL	GPI02	I/O	?	?	?	UNUSED
XCAL	GPI03	I/O	?	?	?	UNUSED

Device	Name	I/O	Power Well	During Reset	After Reset	Usage
XYCL	GPI0	I/O	?	?	?	UNUSED
XYCL	RTACTIVE	IN	?	?	?	UNUSED

VOLTAGE RAILS

Rail	Typical (V)
V_CPURECORE	1.68V
VCC	5V
VCC3	3.3V
V_3P3_STBY	3.3V Standby
V_2P5	2.65V
V_1P3	1.33V
V_1P5_VTT	1.5V
V_1P25_MEMVTT	1.325V
LAUD_5V_ANALOG	5V
VCC_SW	5V (Switched)
+12V	12V (Switched)
V_LDO_2P5	2.5V
V_1P8	1.875V

BOM CONSOLIDATIONS

NOTE: Components with a * have been consolidated with similar parts. Table below shows the parts which changed. See changelist on share (Tuscany/EVT4/Schematic Review Material) for more information.

REF DES

C4M5, C4N1, C4N4, C4N8, C4N11, C4N13, C4N14, C4N17, C4P4, C5N2
 C4N19, C5N4
 R6F3, R6F4, R8B4, B8G3
 R3G2, R3V2, R6A9, R7B2
 R1C5, R1C7, R1C8, R1C14, R1C15
 R4R3, R6E1
 R1D1, R1D5, R1P2, R17C1
 R6D1, R7C1
 R1C3, R1C4, R1C10, R1D2, R1D10, R1P3, R2B1, R2B2, R2B4, R2B6,
 R4M7, R4M10, R4P1, R5A1, R5G1, R5M3, R6A1, R6A2, R6A4, R6U1,
 R7C4, R7D3, R7E12, R7M4, R7M6, R8B5
 R1D6, R6B3, R7E8, R7R2

OLD PART

X602431-025 Cap, S/M, X7R, 0.01uF, 50V, 20%, 0603
 X626747-046 Cap, S/M, X7R, 0.01uF, 50V, 5%, 0603
 X202285-053 Res, S/M, 1.5k, 5%, 1/16W, 0603
 X202285-025 Res, S/M, 100 ohm, 5%, 1/16W, 0603
 X202285-029 Res, S/M, 150 ohm, 5%, 1/16W, 0603
 X202286-068 Res, S/M, 49.90 ohm, 1%, 1/16W, 0603
 X202285-019 Res, S/M, 56 ohm, 5%, 1/16W, 0603
 XA36093-016 Res, S/M, 1K ohm, 5%, 1/16W, 0402
 X202285-049 Res, S/M, 1K ohm, 5%, 1/16W, 0603

X202285-065 Res, S/M, 4.7k ohm, 5%, 1/16W, 0603

NEW PART

X603269-020 Cap, S/M, X7R, 0.01uF, 50V, 10%, 0603
 X603269-020 Cap, S/M, X7R, 0.01uF, 50V, 10%, 0603
 X202286-211 Res, S/M, 1.54K ohm, 1%, 1/16W, 0603
 X202286-097 Res, S/M, 100.0 ohm, 1%, 1/16W, 0603
 X202286-114 Res, S/M, 150.0 ohm, 1%, 1/16W, 0603
 XA36092-045 Res, S/M, 49.90 ohm, 1%, 1/16W, 0402
 X202286-073 Res, S/M, 56.20 ohm, 1%, 1/16W, 0603
 X202286-193 Res, S/M, 1.0K ohm, 1%, 1/16W, 0603
 X202286-193 Res, S/M, 1.0K ohm, 1%, 1/16W, 0603

X202286-258 Res, S/M, 4.75K ohm, 1%, 1/16W, 0603

7/15/22

Initial release

Remade in KiCad

Microsoft

Sheet: /GPIO Table & Voltage Rails/

File: gpio-voltage.kicad_sch

Title: Tuscany Fab K

Size: B

Date: 3/15/2004

Rev: 5.1

KiCad E.D.A. kicad (6.0.6)

Id: 2/40

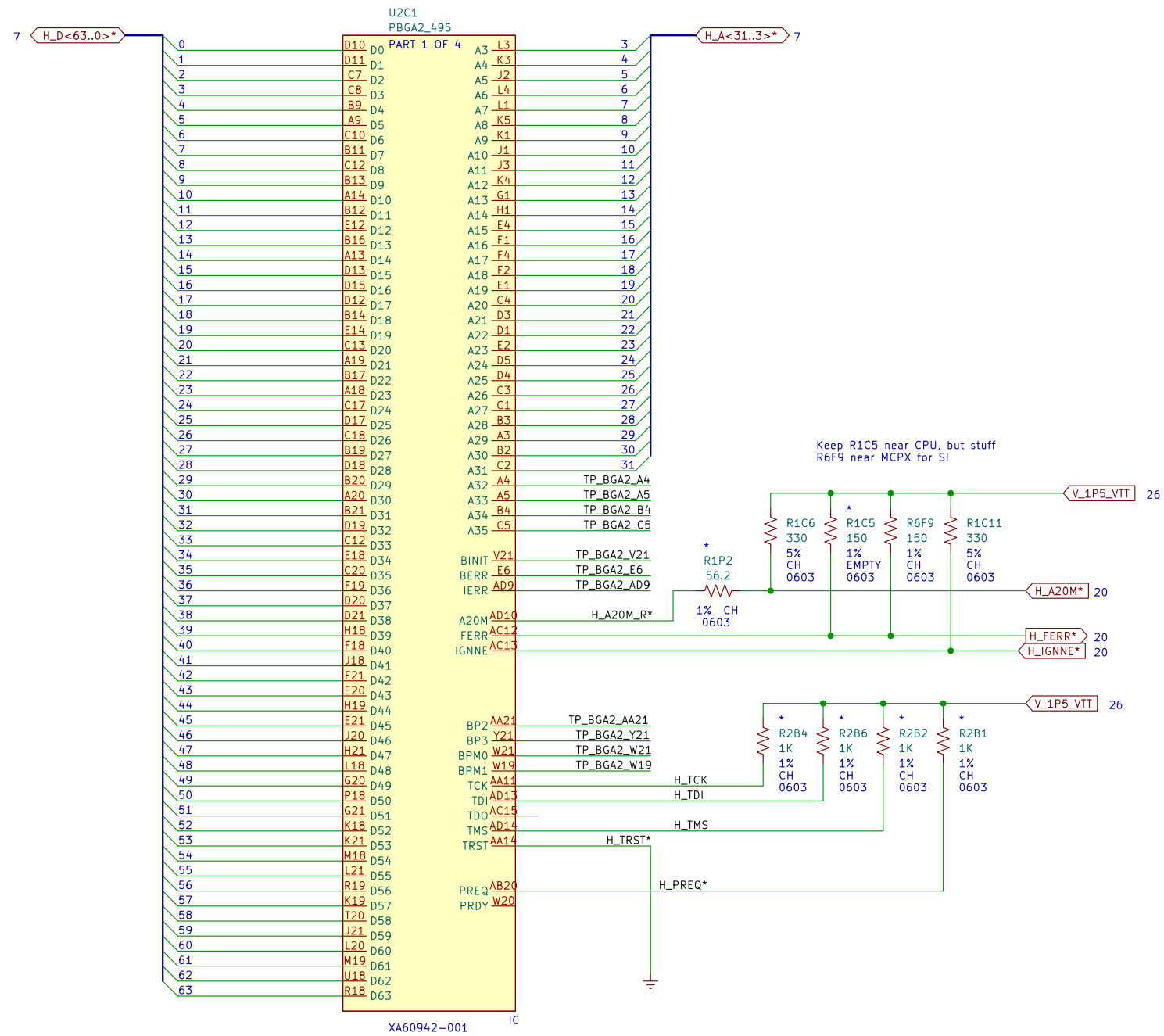

NC: A15, A16, A17, C14, D8, D14, D16, E15, G2, G5, G18, H3, H5, J5, M4, M5, P3, P4, AA5, AA19, AC3, AC20, AD15
 GND: A2, A7, A8, A12, A21, B1, B5, B6, B7, B8, B10, B15, B18, C9, C11, C15, C16, C19, D2, D6, D7, D9, E3, E7, E8, E9
 GND: E10, E11, E13, E19, F3, F6, F7, F8, F9, F10, F11, F12, F13, F14, F15, F16, F20, G3, G19, H2, H7, H9, H11, H13, H15
 GND: H20, J4, J8, J10, J12, J14, J16, J19, K2, K7, K9, K11, K13, K15, K20, L5, L8, L10, L12, L14, L16, L19, M7, M9, M11
 GND: M13, M15, M20, N2, N3, N4, N8, N10, N12, N14, N16, N18, N19, N20, P5, P7, P9, P11, P13, P15, R3, R4, R5, R8, R10, R12, R14, R16, R20
 GND: T3, T5, T7, T9, T11, T13, T15, T18, T19, U8, U10, U12, U14, U16, U20, V3, V19, W4, W18, Y3, Y9, Y10, Y11, Y12, Y13, Y14, Y15, Y16, Y19
 GND: AA4, AA13, AA20, AB3, AB5, AB9, AB11, AB13, AB14, AB17, AC1, AC2, AC5, AC10, AC14, AC16, AC21, AD1, AD5, AD16, AD21, AC18

7/15/22
 Initial release
 Remade in KiCad
 Microsoft
 Sheet: /Pentium III BGA2 Part 1 of 4/
 File: p3-1.kicad_sch

Title: Tuscany Fab K

Size: B Date: 3/15/2004
 KiCad E.D.A. kicad (6.0.6)

Rev: 5.1
 Id: 3/40

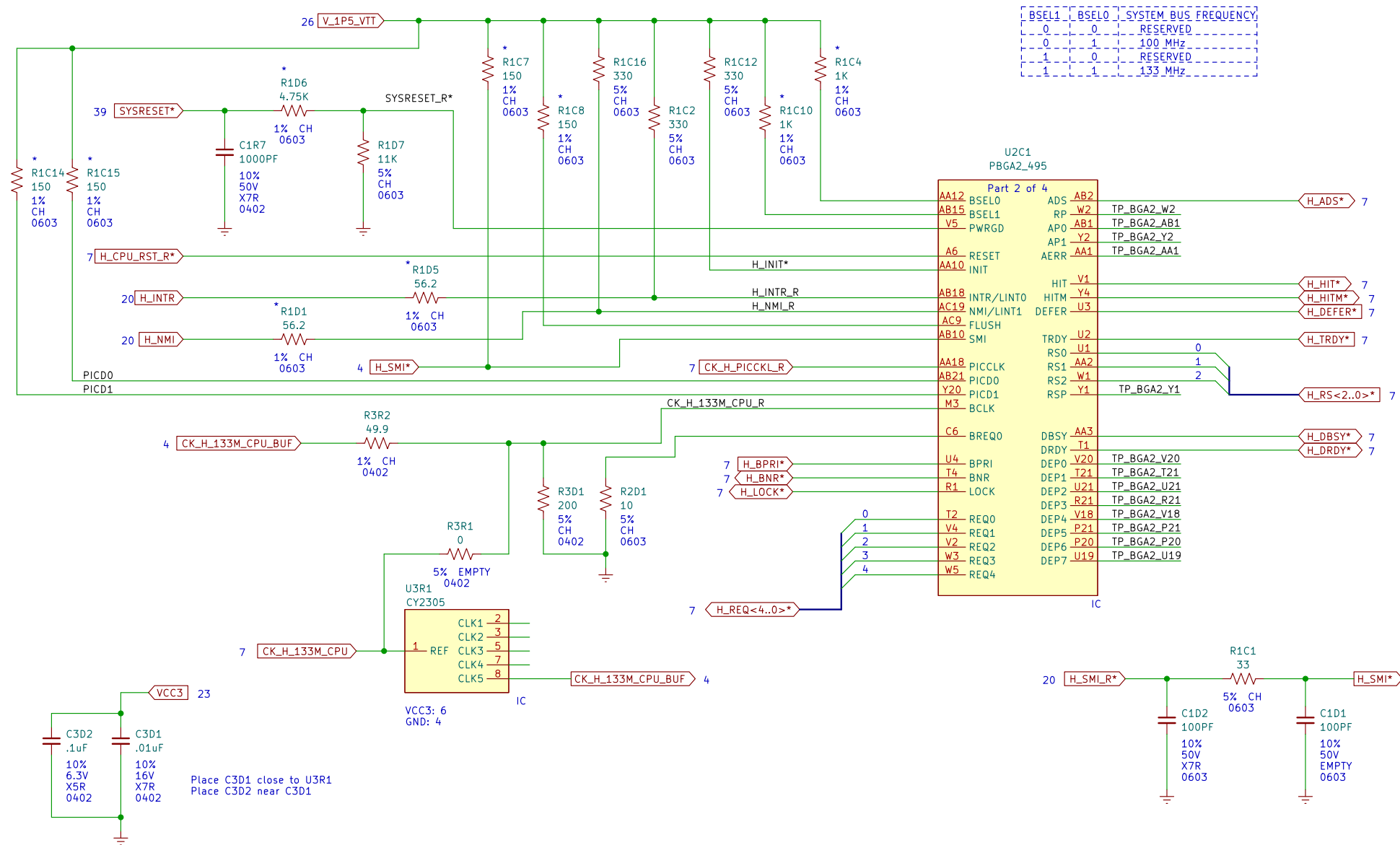

CPU VCORE Decoupling

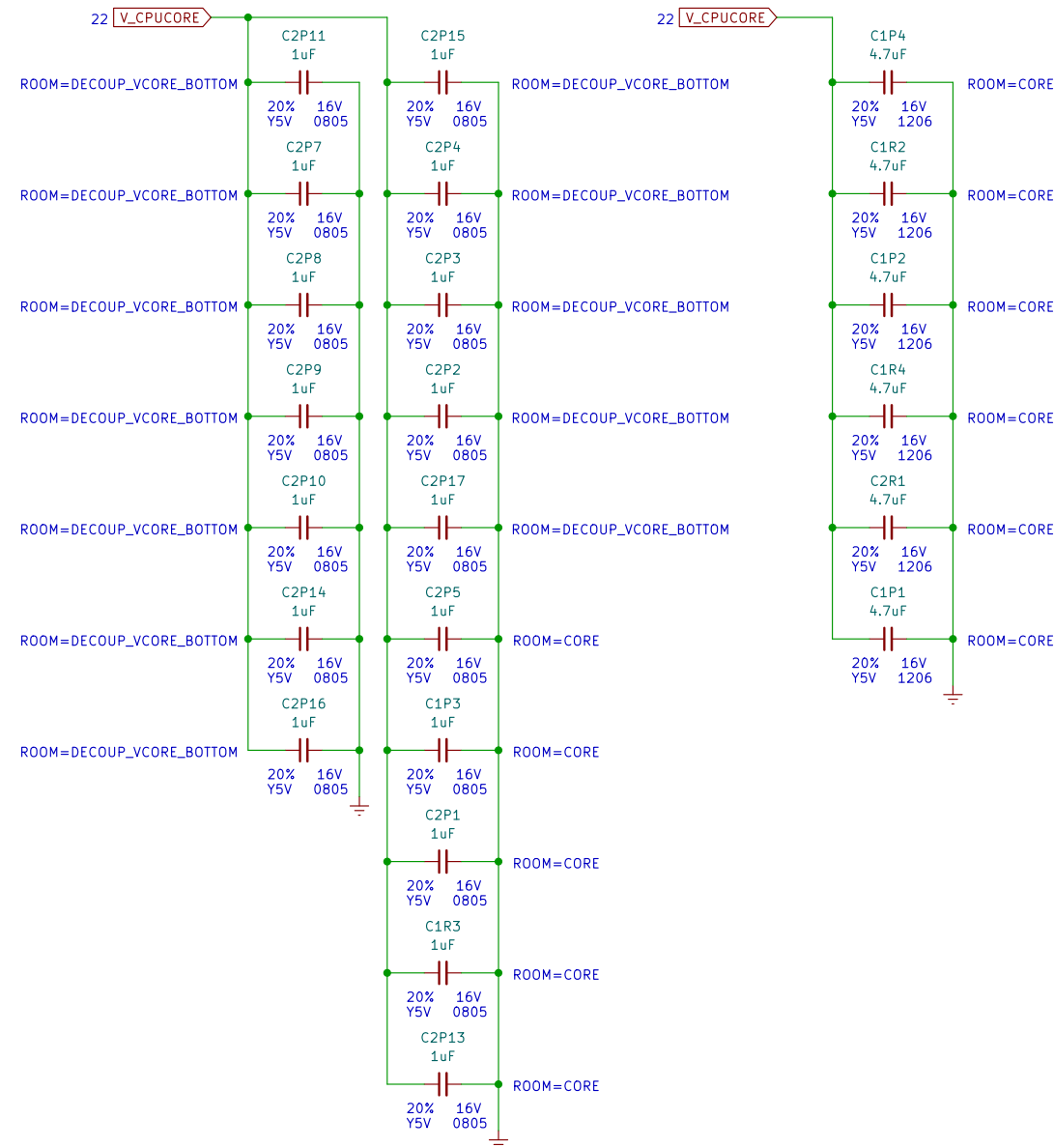

CPU VTT Decoupling

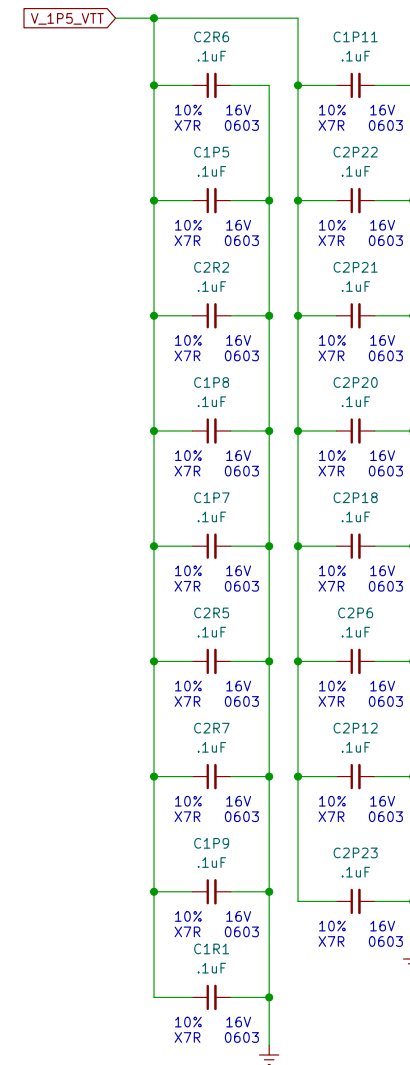

7/15/22		
Initial release		
Remade in KiCad		
Microsoft		
Sheet: /CPU VCORE & VTT Decoupling/		
File: vcore-vtt-decoup.kicad_sch		
Title: Tuscany Fab K		
Size: B	Date: 3/15/2004	Rev: 5.1
KiCad E.D.A. kicad (6.0.6)		Id: 6/40

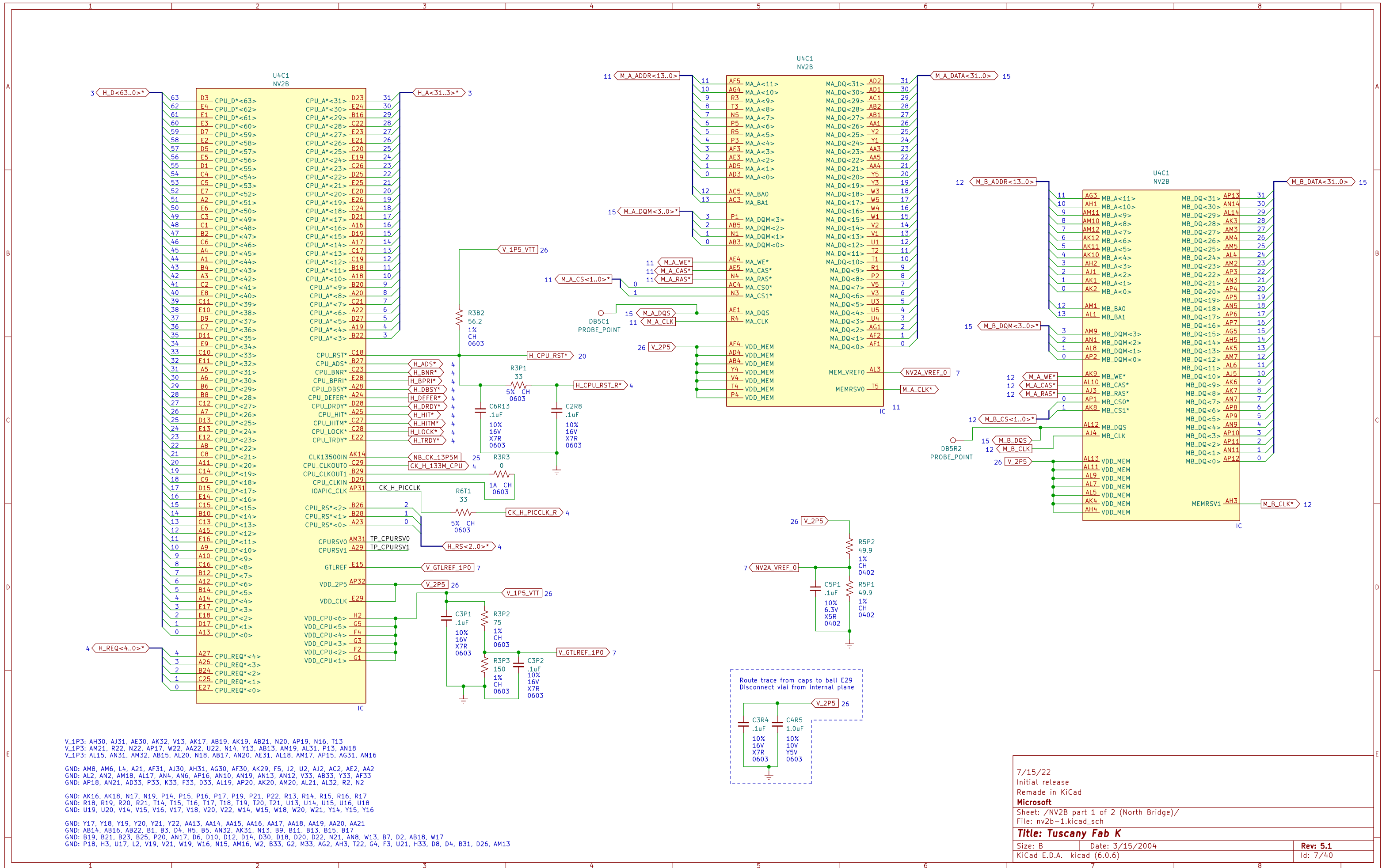

V_1P3: AH30, AJ31, AE30, AK32, V13, AK17, AB19, AK19, AB21, N20, AP19, N16, T13
V_1P3: AM21, R22, N22, AP17, W22, AA22, U22, N14, Y13, AB13, AM19, AL31, P13, AN18
V_1P3: AL15, AN31, AM32, AB15, AL20, N18, AB17, AN20, AE31, AL18, AM17, AP15, AG31, AN16

GND: AM8, AM6, L4, A21, AF31, AJ30, AH31, AG30, AF30, AK29, F5, J2, U2, AJ2, AC2, AE2, AA2
GND: AL2, AN2, AM18, AL17, AN4, AN6, AP16, AN10, AN19, AN13, AN12, V33, AB33, Y33, AF33
GND: AP18, AN21, AD33, P33, K33, F33, D33, AL19, AP20, AK20, AM20, AL21, AL32, R2, N2

GND: AK16, AK18, N17, N19, P14, P15, P16, P17, P19, P21, P22, R13, R14, R15, R16, R17
GND: R18, R19, R20, R21, T14, T15, T16, T17, T18, T19, T20, T21, U13, U14, U15, U16, U18
GND: U19, U20, V14, V15, V16, V17, V18, V20, V22, W14, W15, W18, W20, W21, Y14, Y15, Y16

GND: Y17, Y18, Y19, Y20, Y21, Y22, AA13, AA14, AA15, AA16, AA17, AA18, AA19, AA20, AA21
GND: AB14, AB16, AB22, B1, B3, D4, H5, B5, AN32, AK31, N13, B9, B11, B13, B15, B17
GND: B19, B21, B23, B25, P20, AN17, D6, D10, D12, D14, D30, D18, D20, D22, N21, AN8, W13, B7, D2, AB18, W17
GND: P18, H3, U17, L2, V19, V21, W19, W16, N15, AM16, W2, B33, G2, M33, AG2, AH3, T22, G4, F3, U21, H33, D8, D4, B31, D26, AM13

7/15/22
Initial release
Remade in KiCad
Microsoft
Sheet: /NV2B part 1 of 2 (North Bridge)/
File: nv2b-1.kicad_sch
Title: Tuscany Fab K
Size: B Date: 3/15/2004 Rev: 5.1
KiCad E.D.A. kicad (6.0.6) Id: 7/40

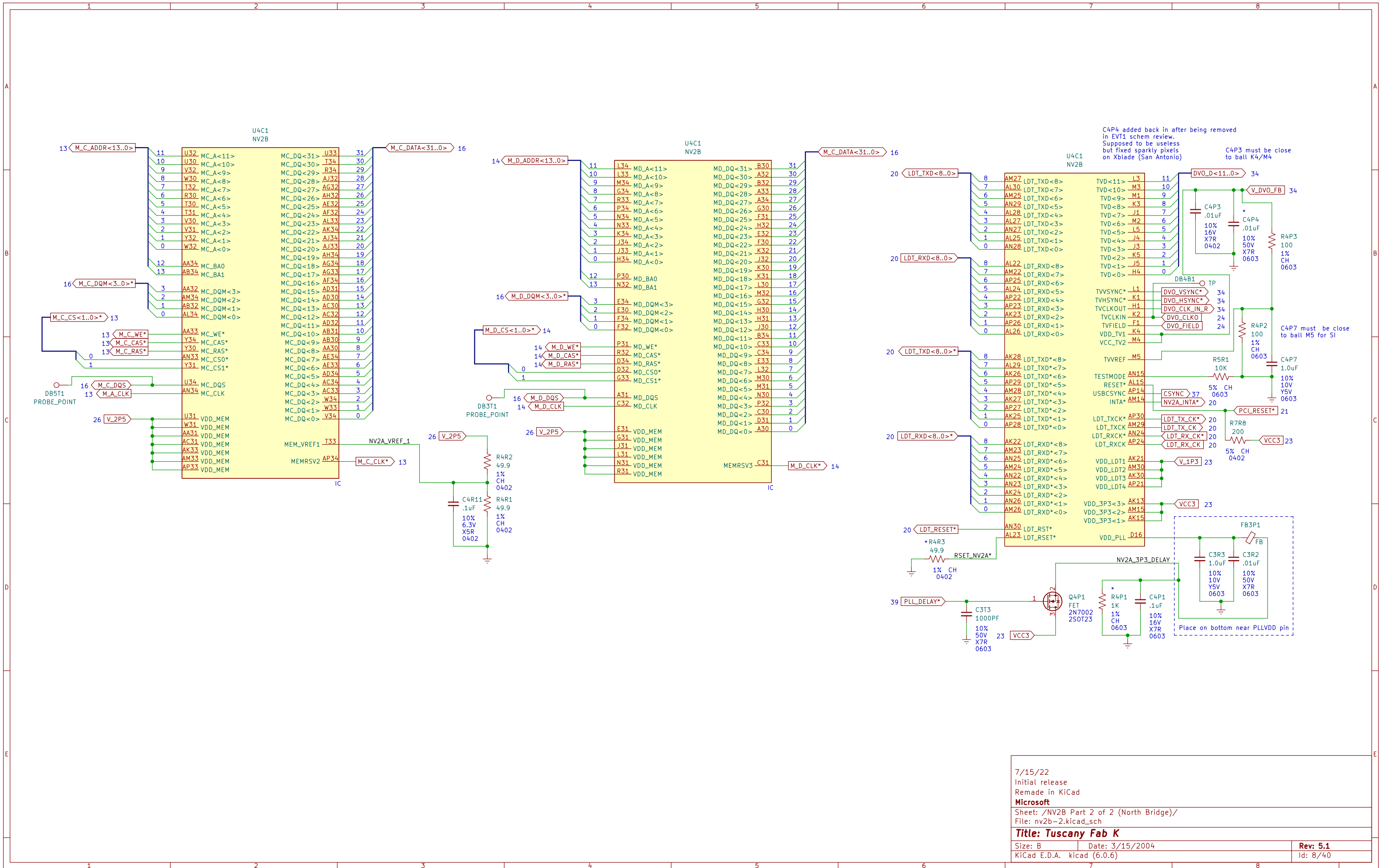

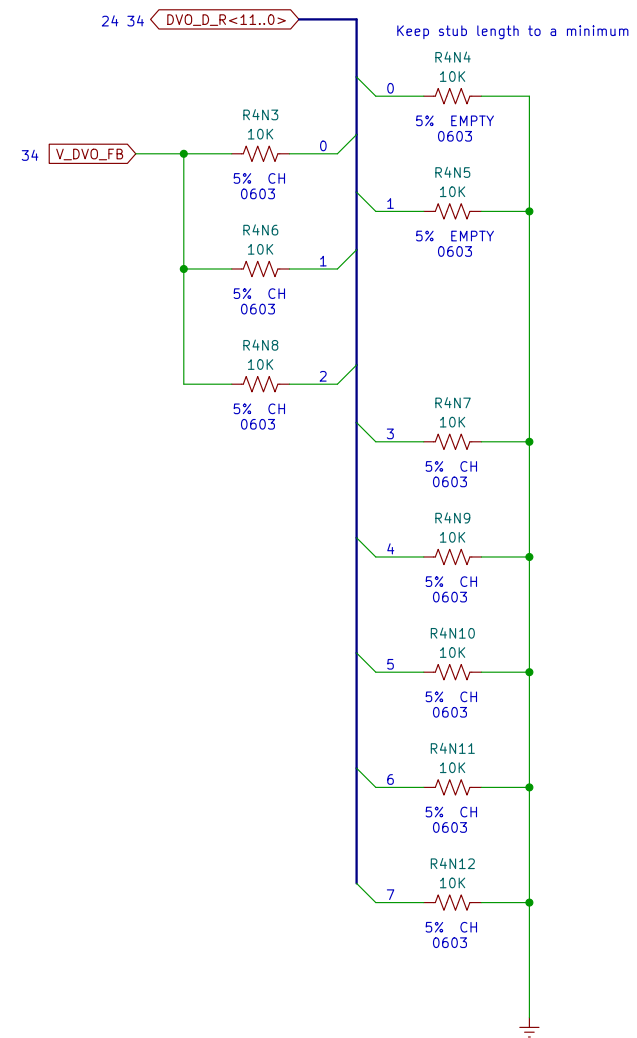

TV D		DEFINITION
[7]	0*	Enable internal LDT termination
	1	Disable internal LDT termination
[6]	0*	13.5MHz or 16.6MHz
	1	14.31818MHz
[5:4]	00*	Use FSB frequency based on TVD[3:2]
	01	Use internal programmed value A
	10	Use internal programmed value B
	11	Force 66MHz
[3:2]	00	NA
	01*	FSB Frequency = 133MHz for 16.6MHz input clock
	10	NA
	11	NA
[1:0]	00*	Bits [1:0] are unused on Tuscany
	01	Used to be memory drive strength settings
	10	Now all settings are read from the EEPROM
	11	

* = CURRENT SETTING

7/15/22

Initial release

Remade in KiCad

Microsoft

Sheet: /NV2B Strapping/

File: nv2b-strapping.kicad_sch

Title: Tuscany Fab K

Size: B

Date: 3/15/2004

Rev: 5.1

KiCad E.D.A. kicad (6.0.6)

Id: 9/40

NV2B Decoupling

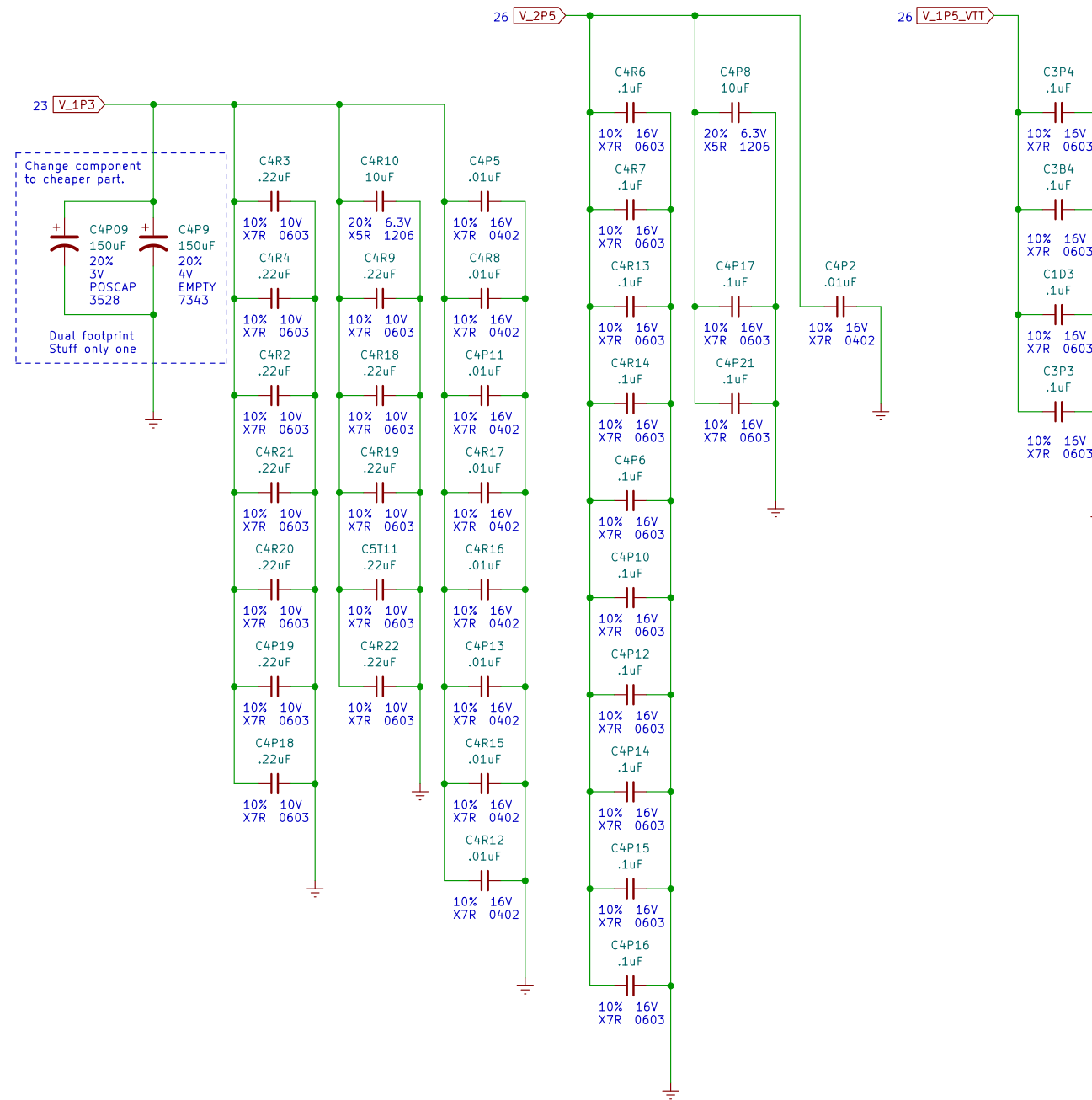

MCPX Decoupling

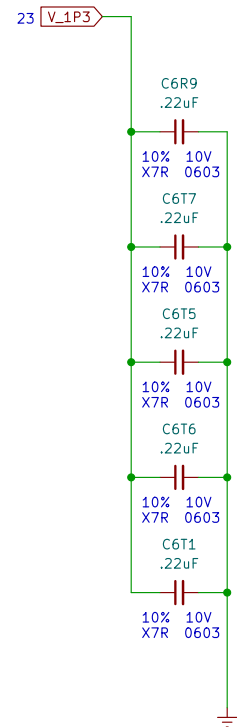

7/15/22		
Initial release		
Remade in KiCad		
Microsoft		
Sheet: /NV2B & MCPX Decoupling/		
File: nv2b-mcp-decoupling.kicad_sch		
Title: Tuscan Fab K		
Size: B	Date: 3/15/2004	Rev: 5.1
KiCad E.D.A. kicad (6.0.6)		Id: 10/40

Memory Interface Partition A

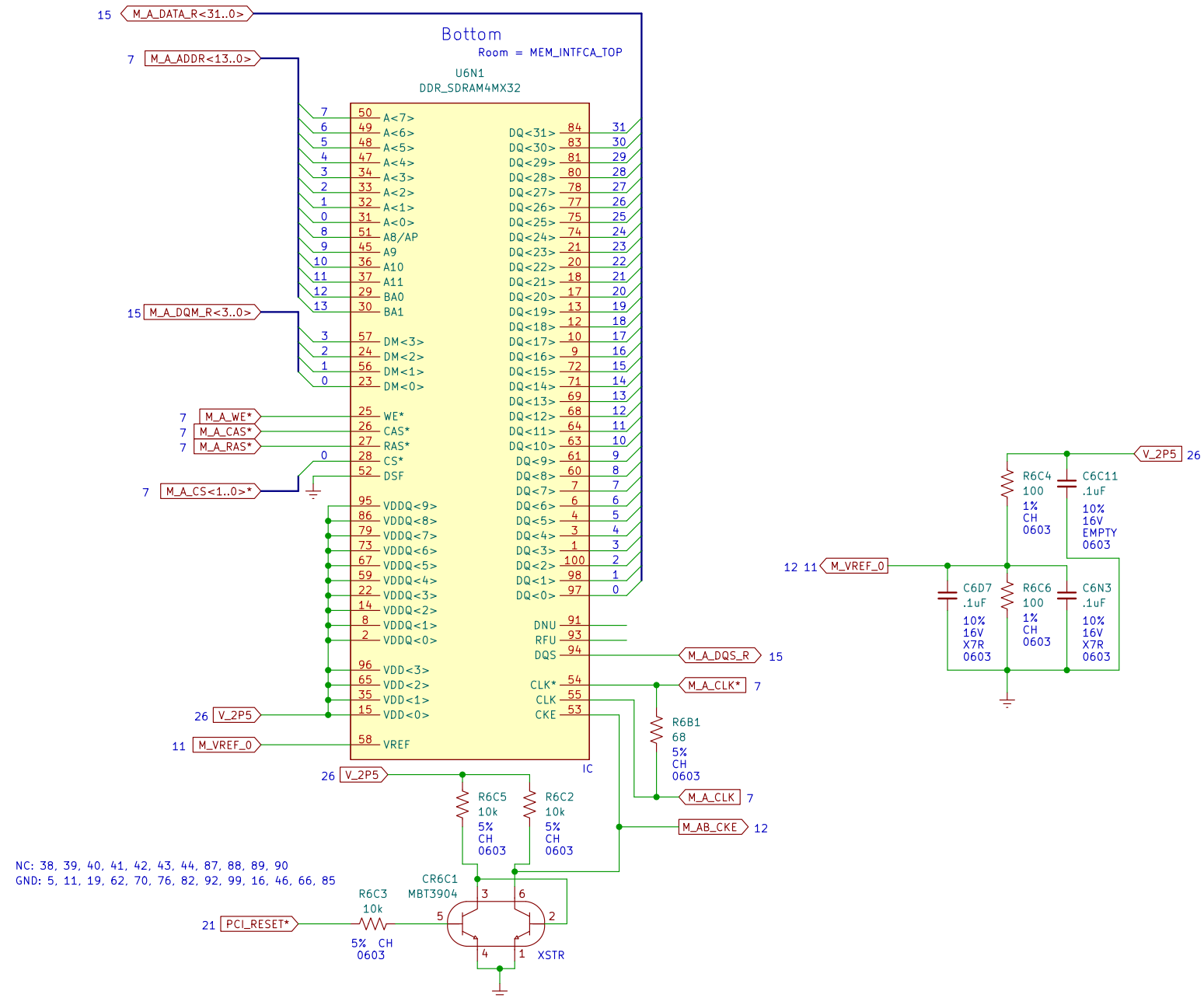

Memory Interface Partition B

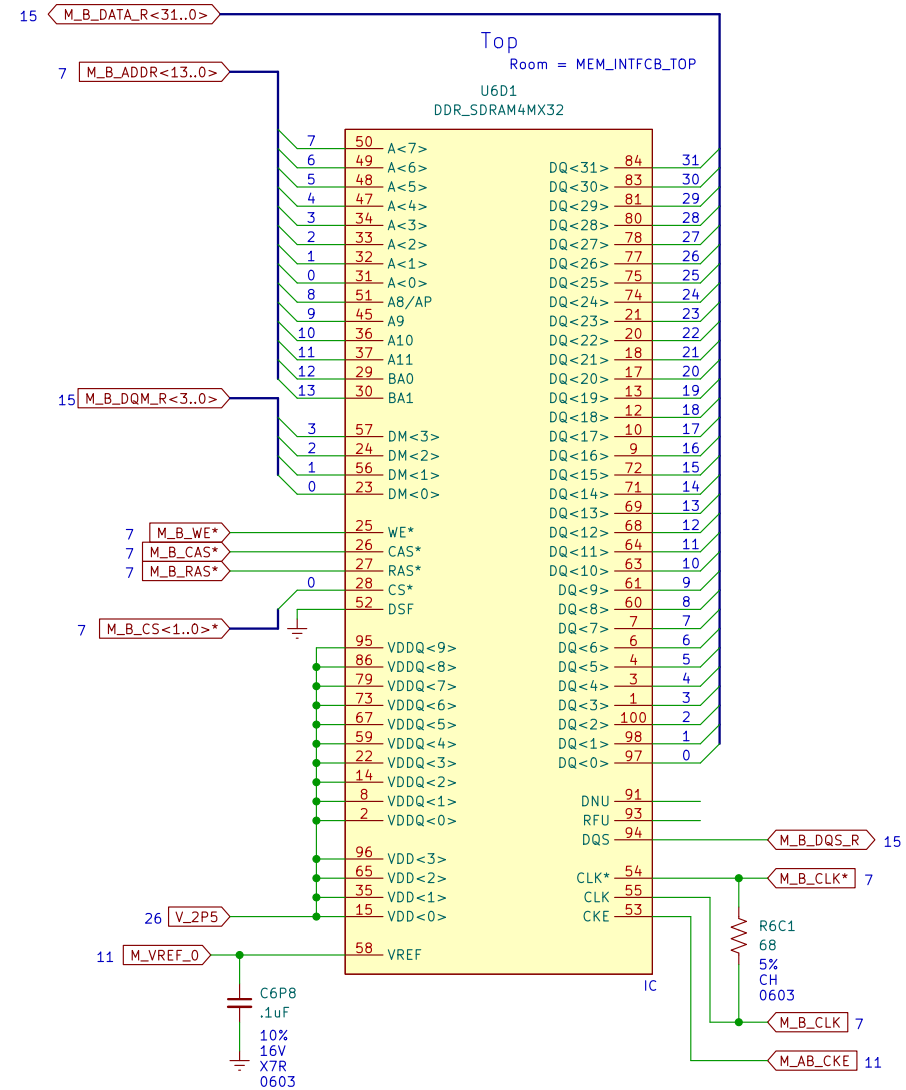

NC: 38, 39, 40, 41, 42, 43, 44, 87, 88, 89, 90
 GND: 5, 11, 19, 62, 70, 76, 82, 92, 99, 16, 46, 66, 85

Memory Interface Partition C

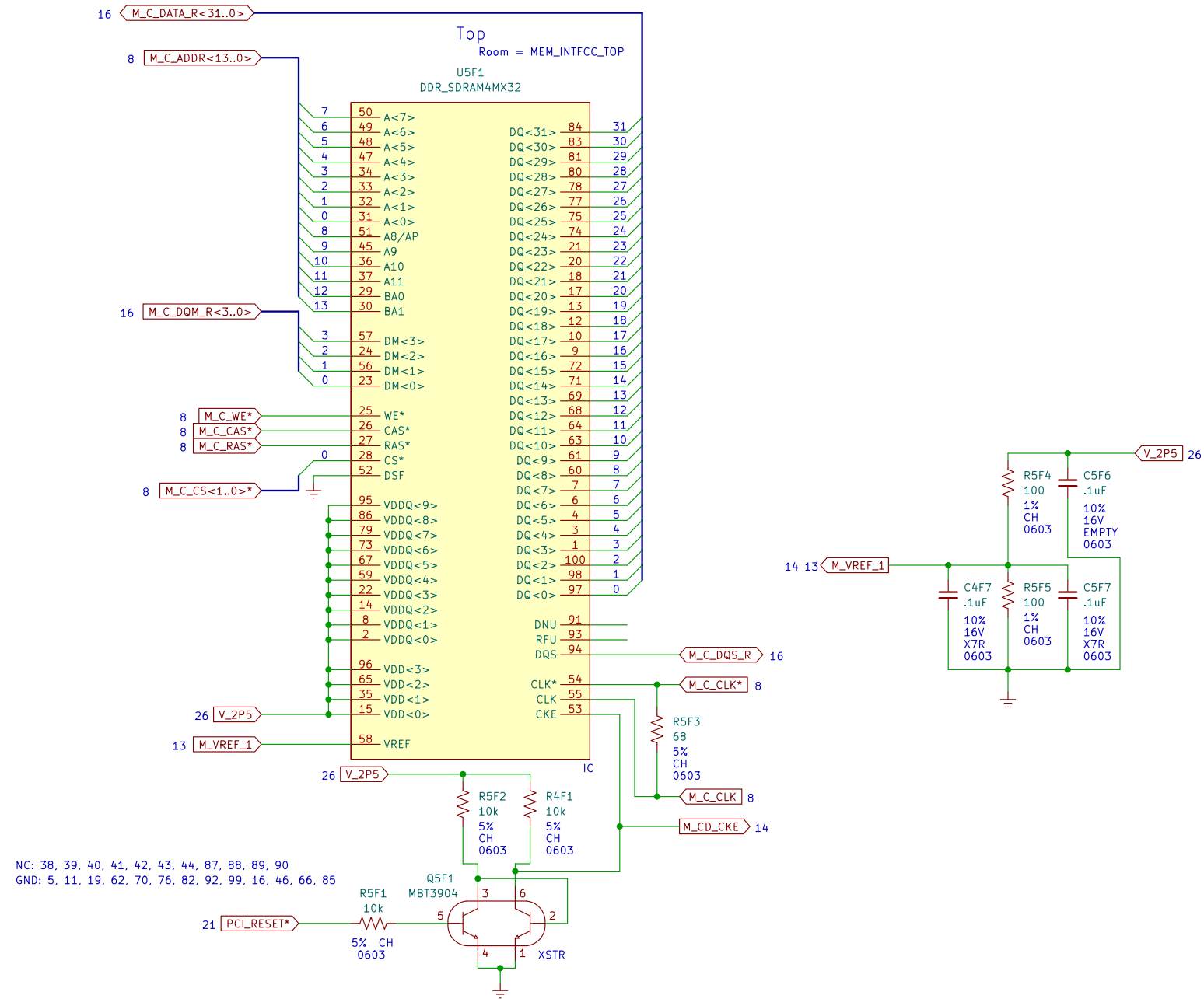

Memory Interface Partition D

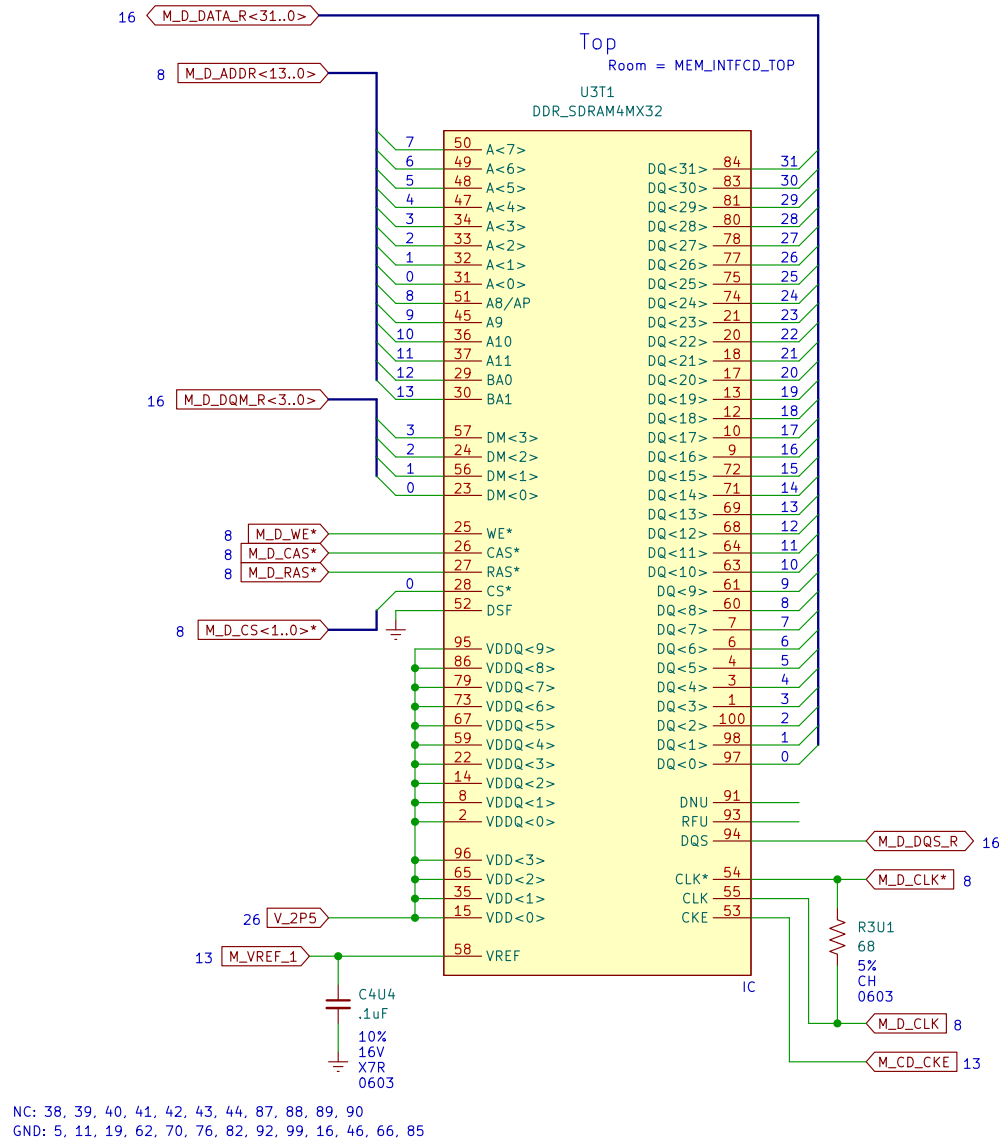

7/15/22

Initial release

Remade in KiCad

Microsoft

Sheet: /DDR SDRAM (Partition D)/

File: ddr-d.kicad_sch

Title: Tuscany Fab K

Size: B

Date: 3/15/2004

Rev: 5.1

KiCad E.D.A. kicad (6.0.6)

Id: 14/40

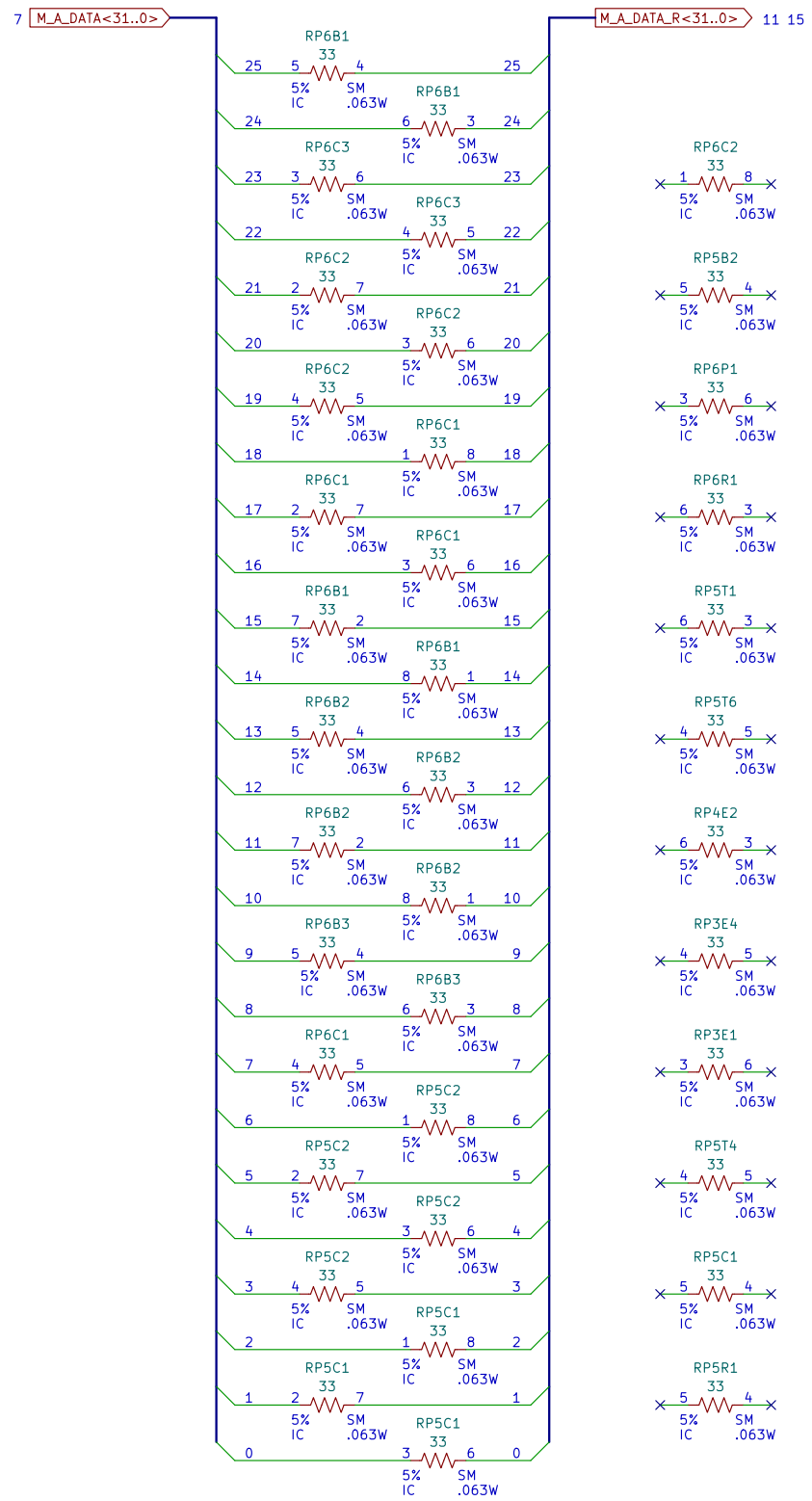

Place all resistor paks near memory

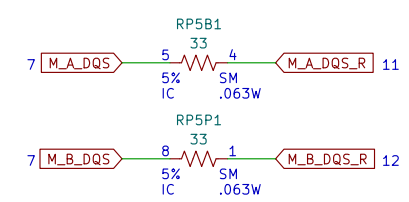
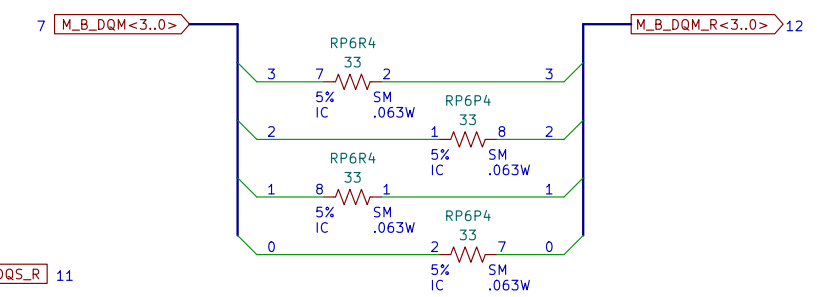
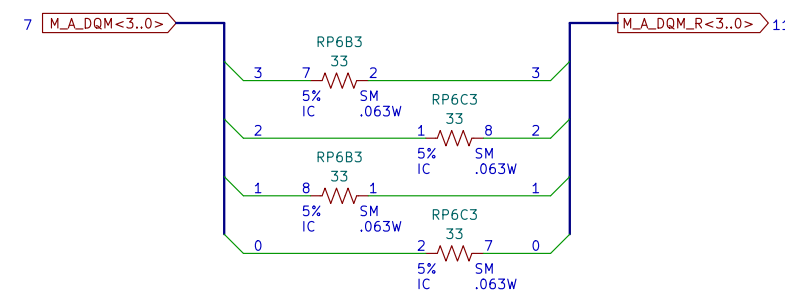
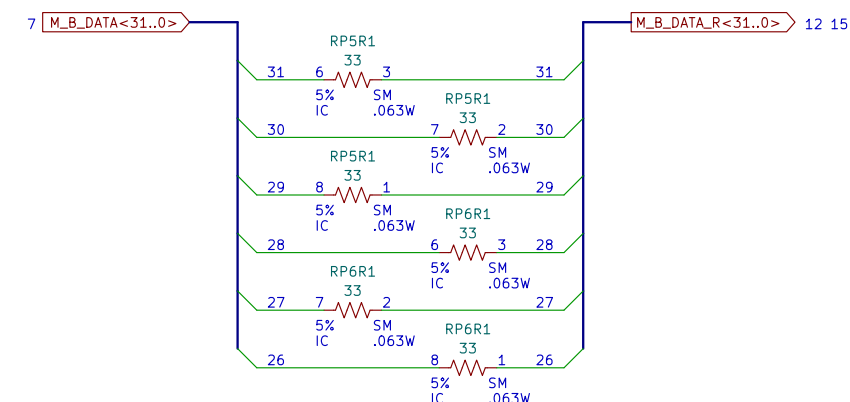
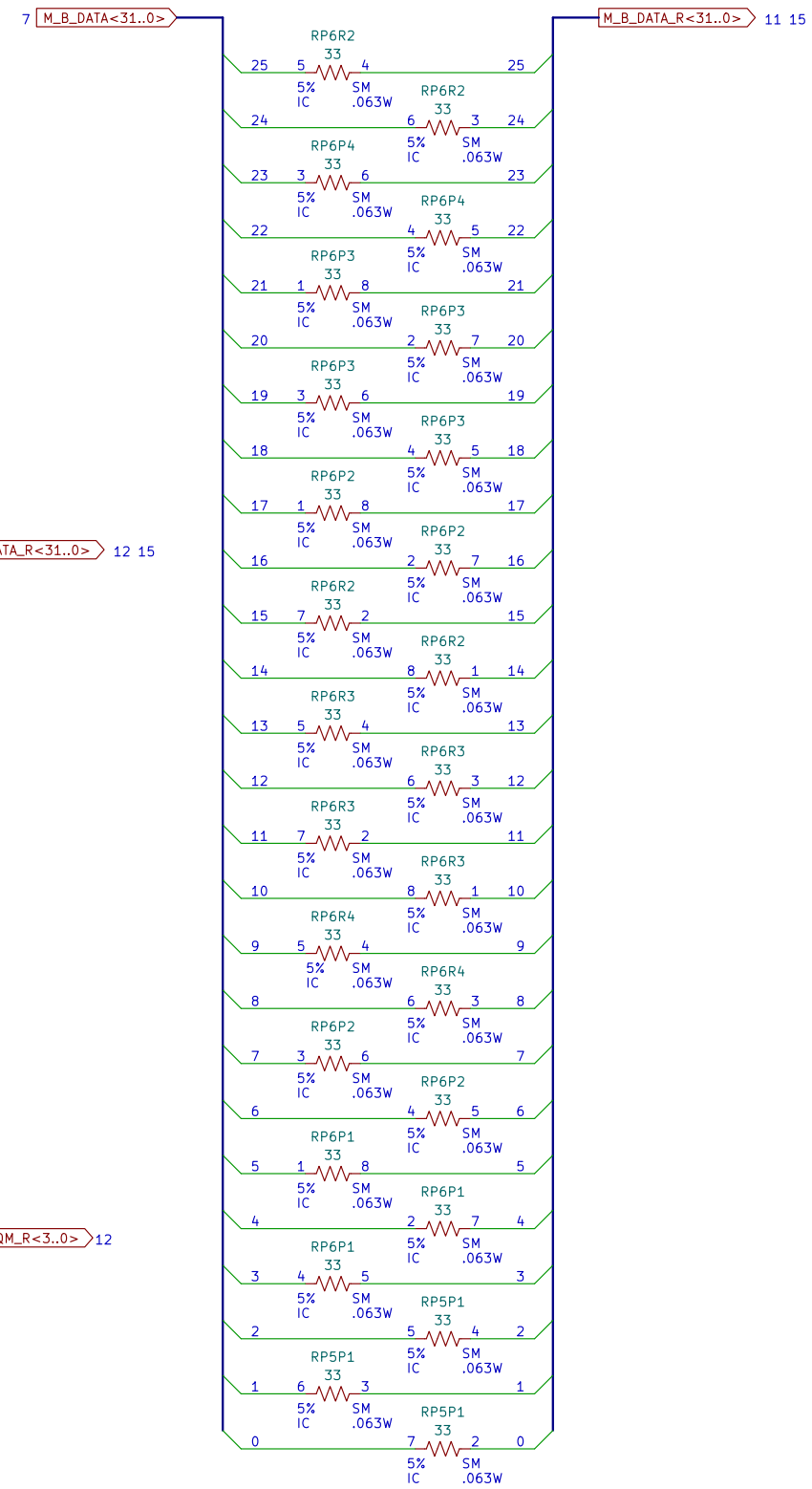
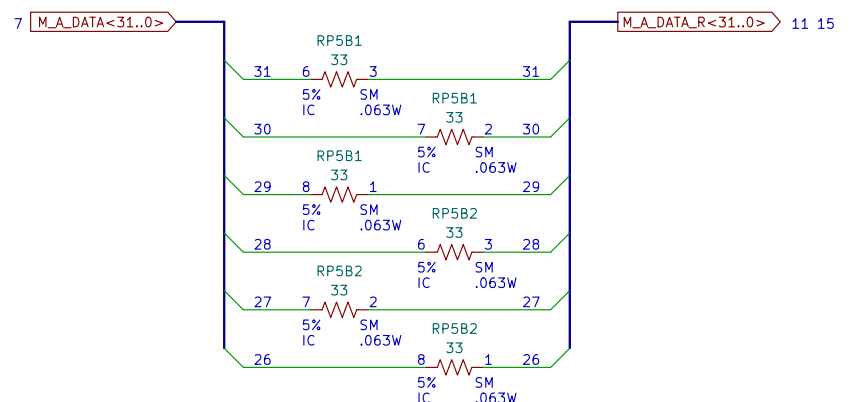

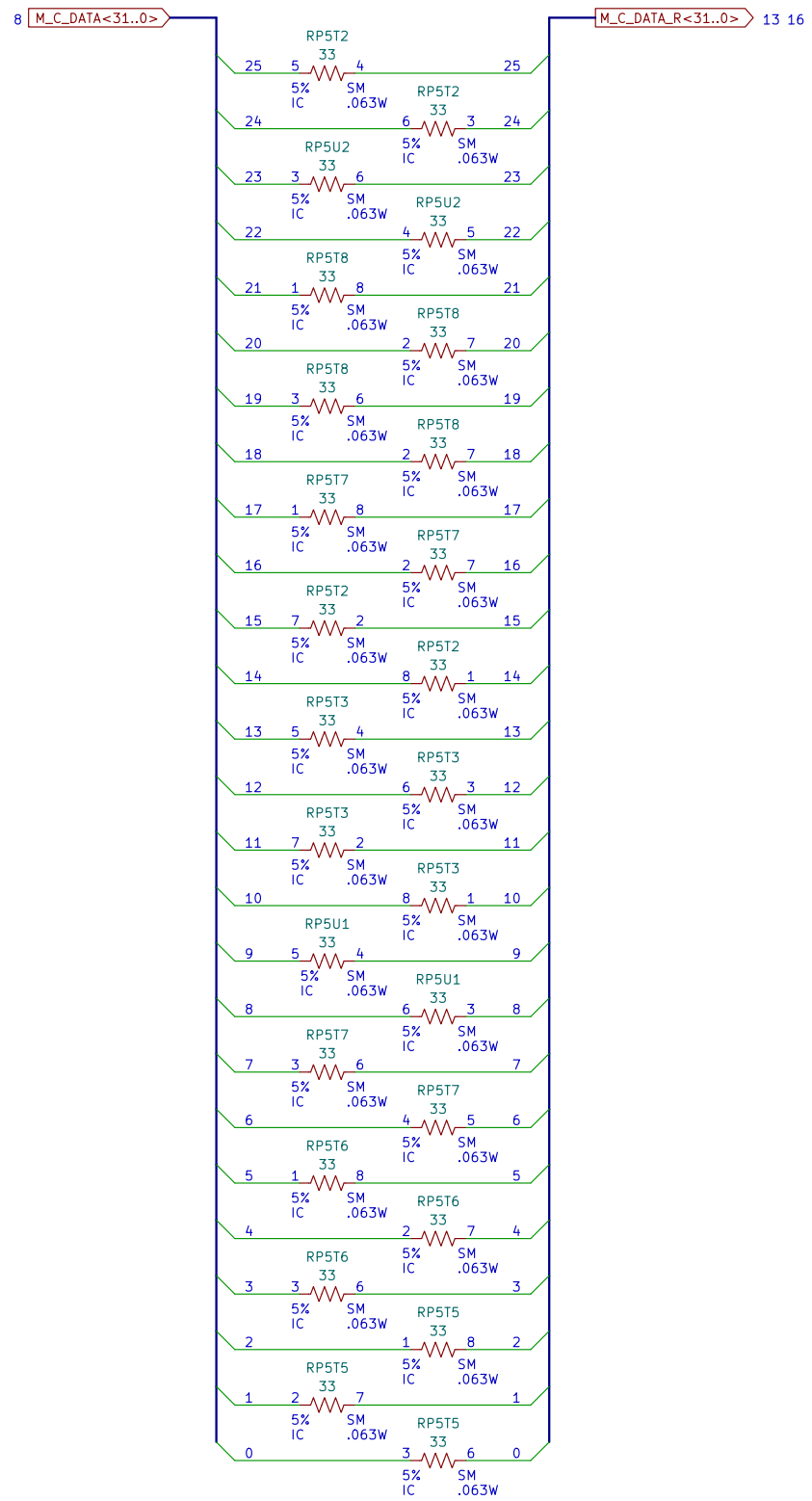

Place all resistor paks near memory

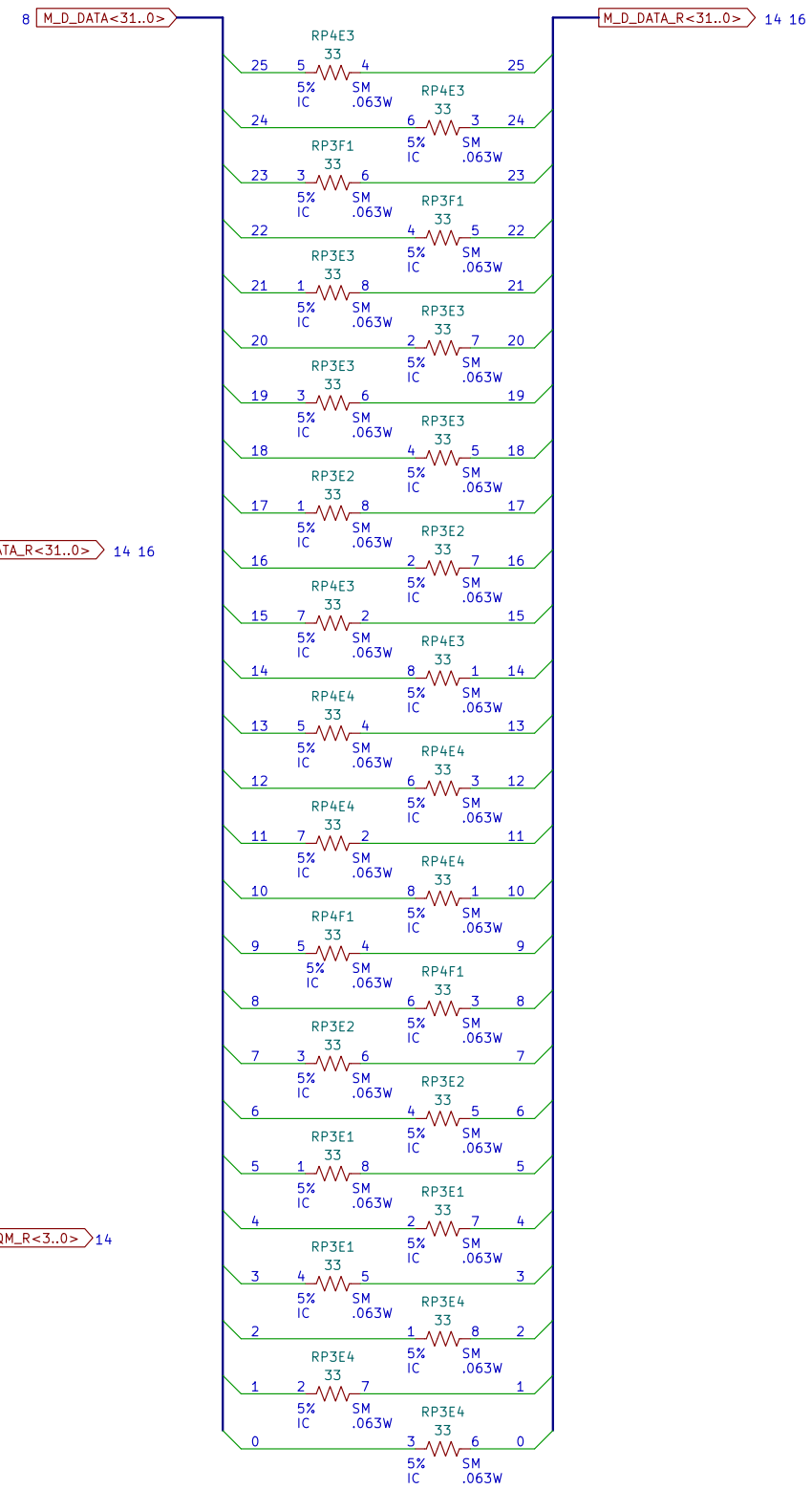
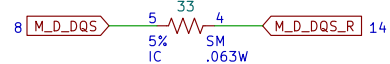
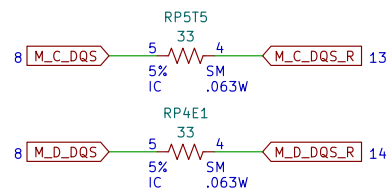
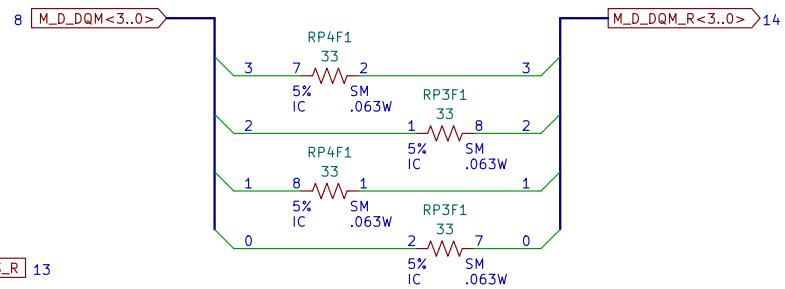
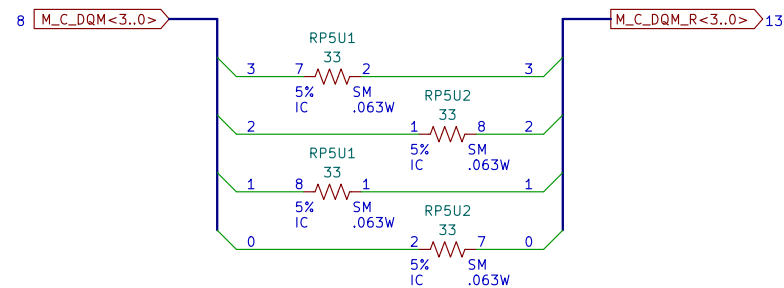
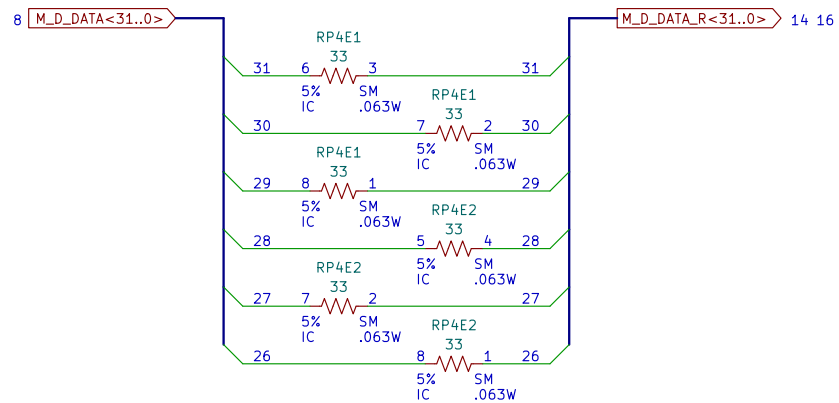
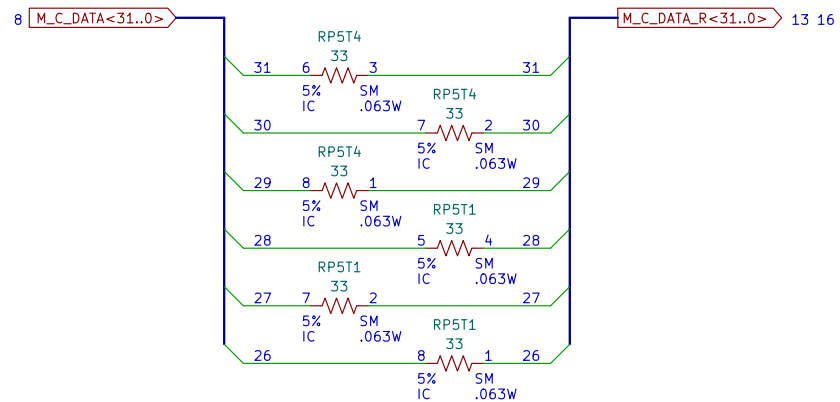

7/15/22
Initial release
Remade in KiCad
Microsoft
Sheet: /DDR Series Term. Data C & D/
File: ddr-series-c-d.kicad_sch

Title: Tuscany Fab K

Size: B Date: 3/15/2004
KiCad E.D.A. kicad (6.0.6)

Rev: 5.1
Id: 16/40

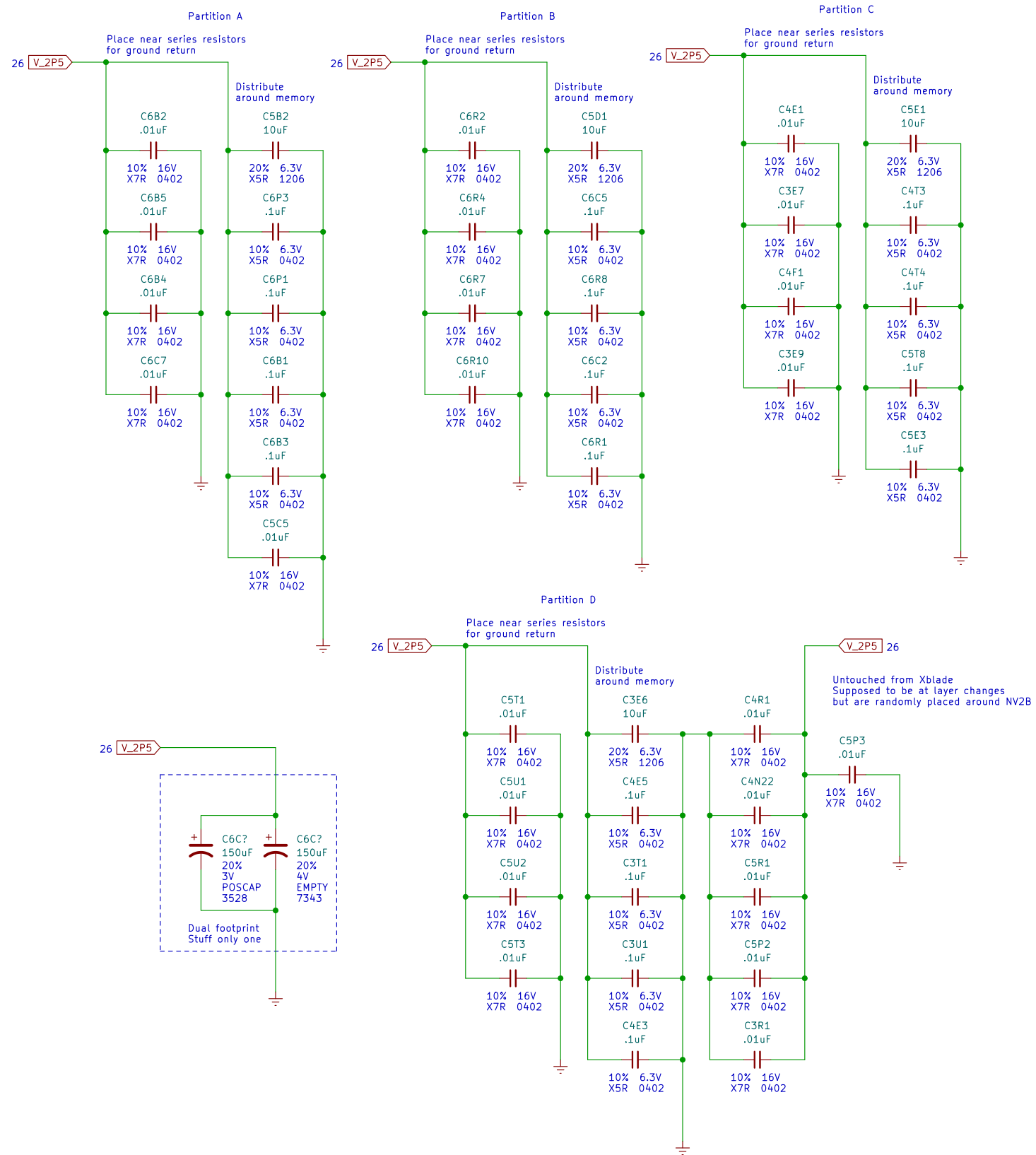

7/15/22		
Initial release		
Remade in KiCad		
Microsoft		
Sheet: /Memory Decoupling/		
File: memory-decoup.kicad_sch		
Title: Tuscany Fab K		
Size: B	Date: 3/15/2004	Rev: 5.1
KiCad E.D.A. kicad (6.0.6)		Id: 17/40

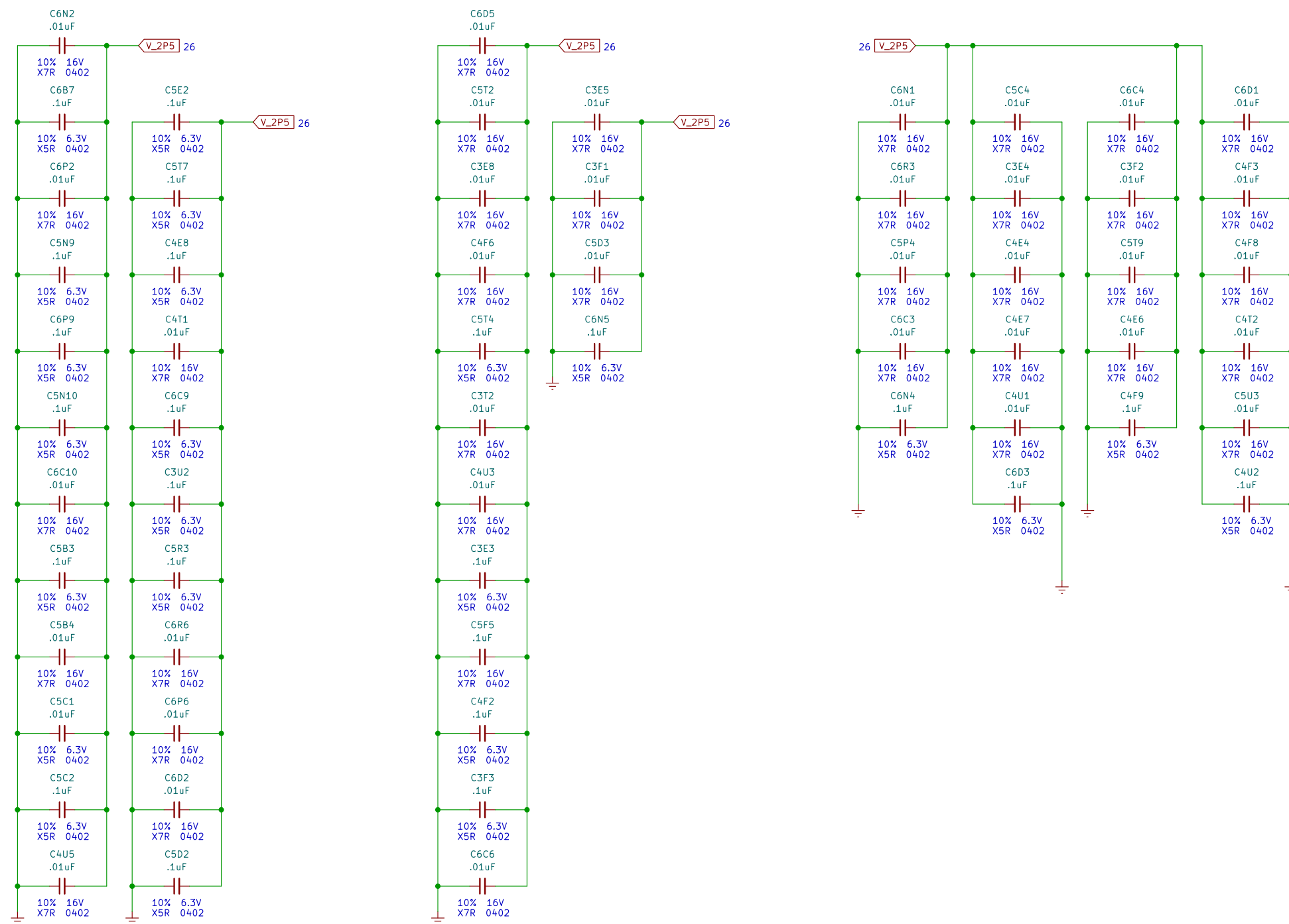

7/15/22		
Initial release		
Remade in KiCad		
Microsoft		
Sheet: /Memory Decoupling/		
File: memory-decoup-2.kicad_sch		
Title: Tuscany Fab K		
Size: B	Date: 3/15/2004	Rev: 5.1
KiCad E.D.A. kicad (6.0.6)		Id: 18/40

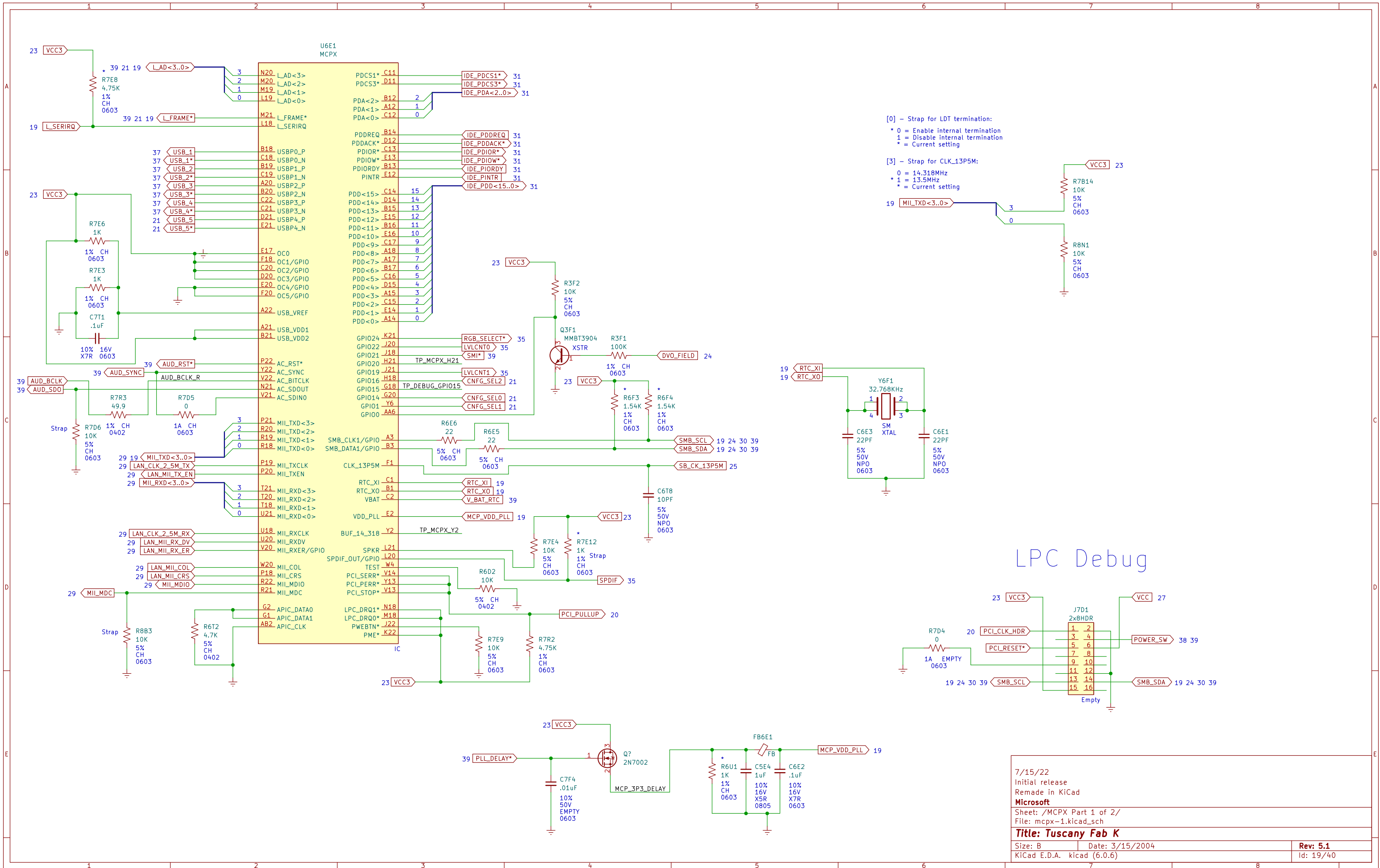

LPC Debug

7/15/22
 Initial release
 Remade in KiCad
Microsoft
 Sheet: /MCPX Part 1 of 2/
 File: mcp-1.kicad_sch
Title: Tuscany Fab K
 Size: B Date: 3/15/2004 Rev: 5.1
 KiCad E.D.A. kicad (6.0.6) Id: 19/40

CNFG_SEL input straps are undefined on Tuscany
 These were used on Xblade

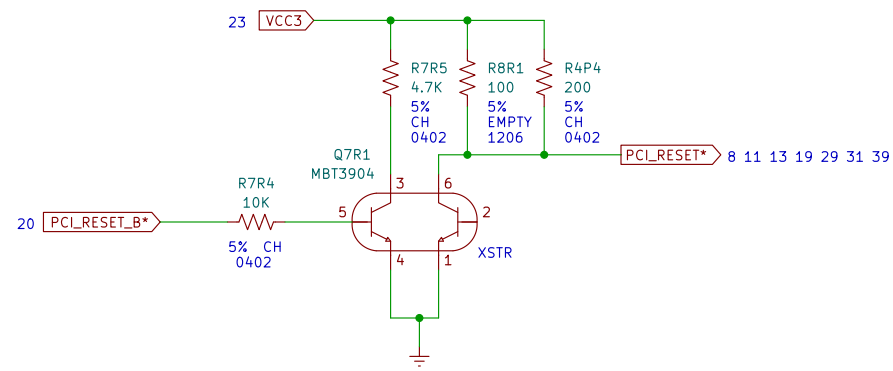
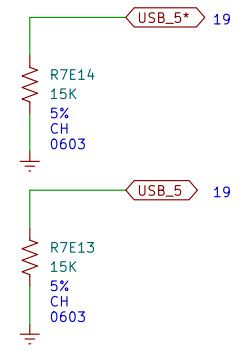
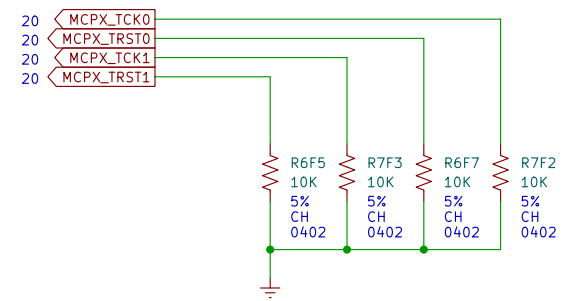
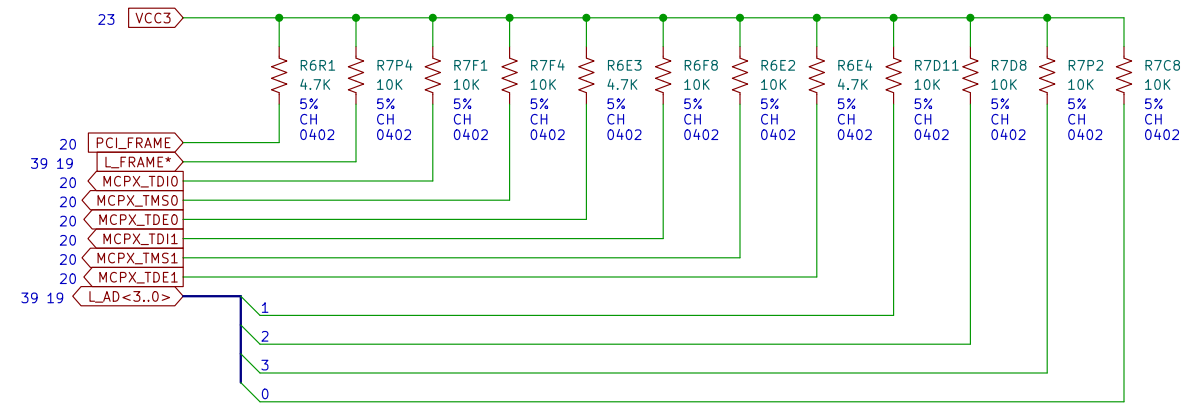
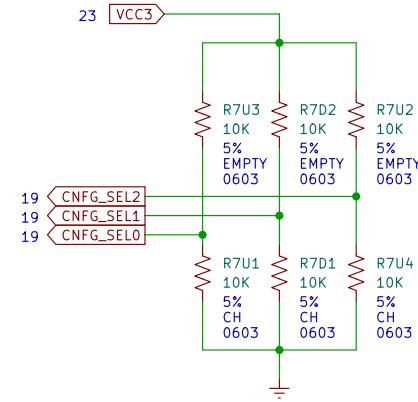

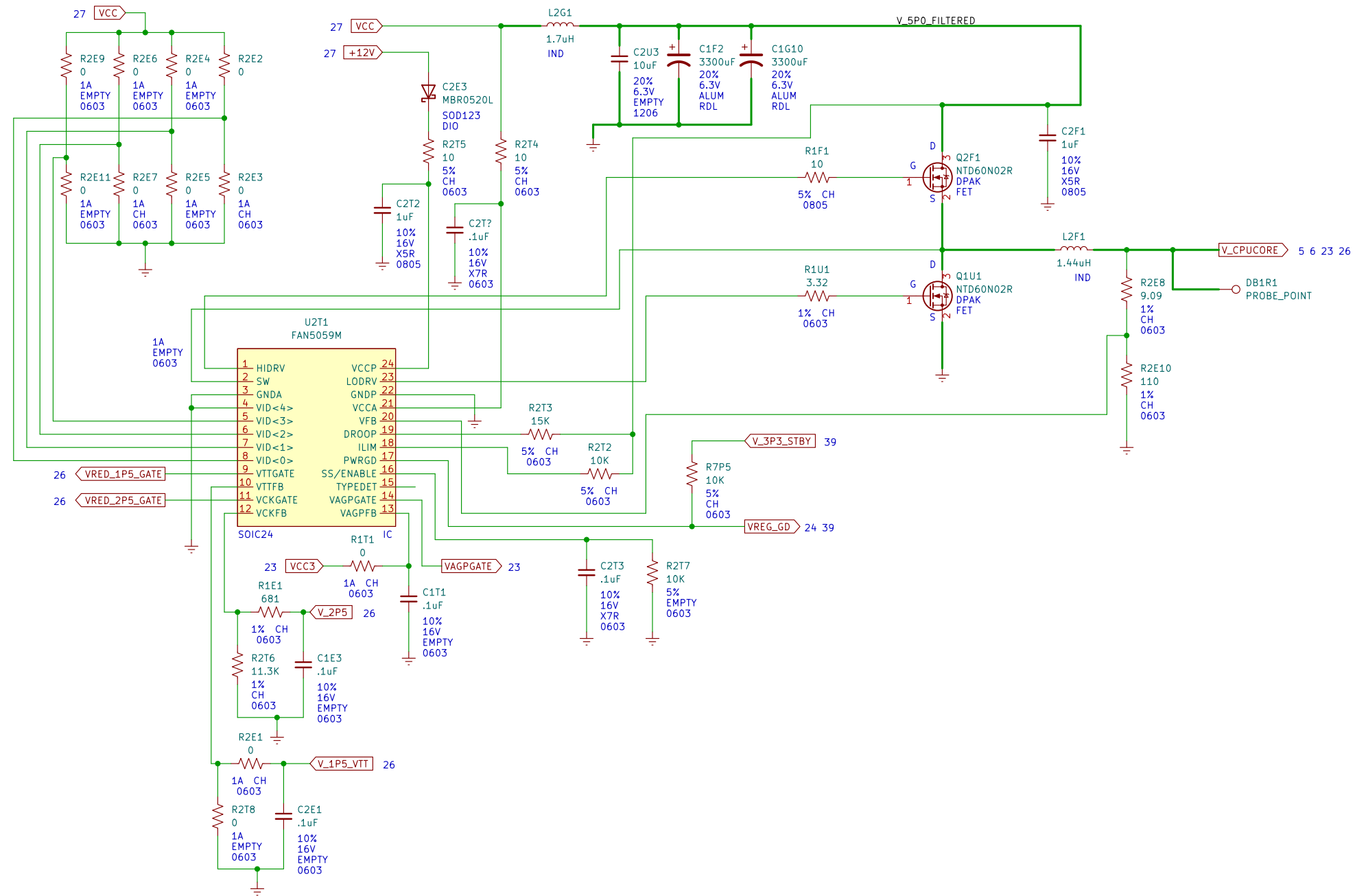

7/15/22

Initial release

Remade in KiCad

Microsoft

Sheet: /Voltage Regulator 1.5V/

File: vreg-1p5.kicad_sch

Title: Tuscany Fab K

Size: B

Date: 3/15/2004

Rev: 5.1

KiCad E.D.A. kicad (6.0.6)

Id: 22/40

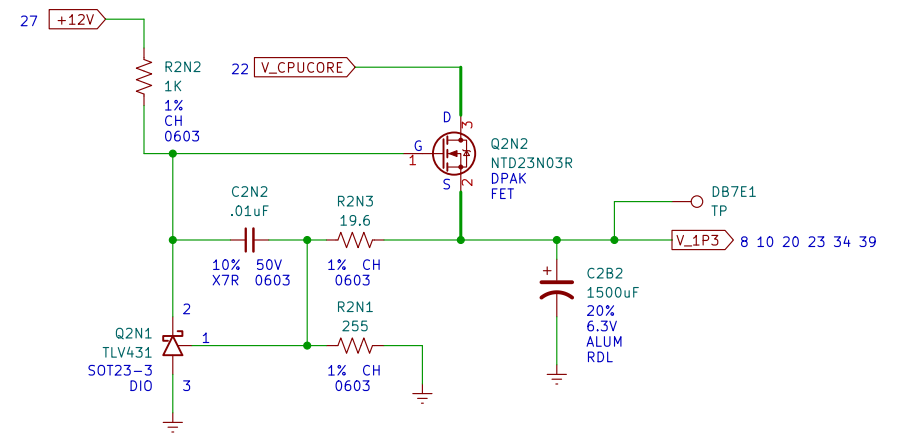
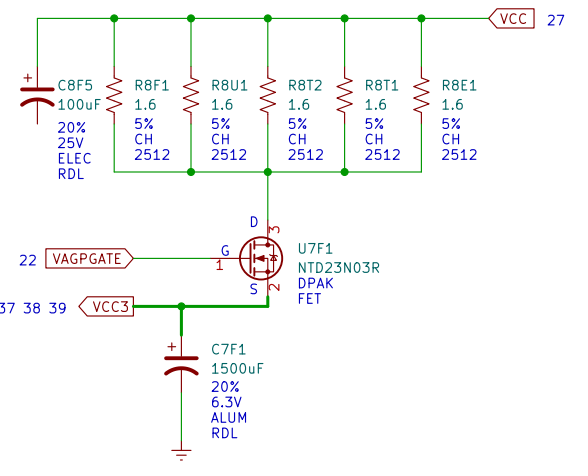
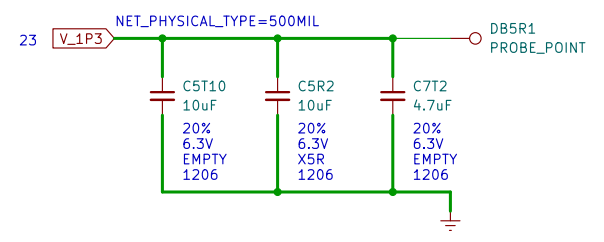
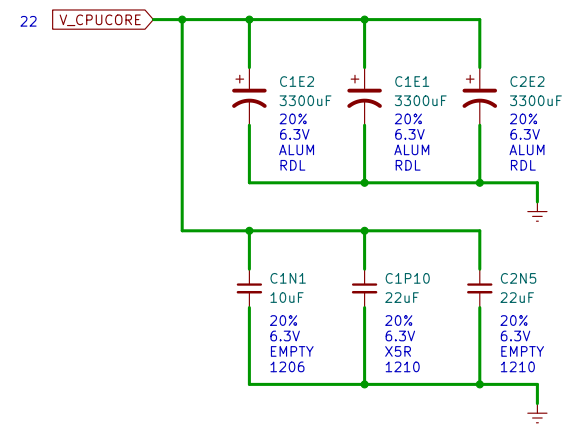

4 8 19 20 21 22 24 25 26 27 28 29 30 31 34 35 37 38 39

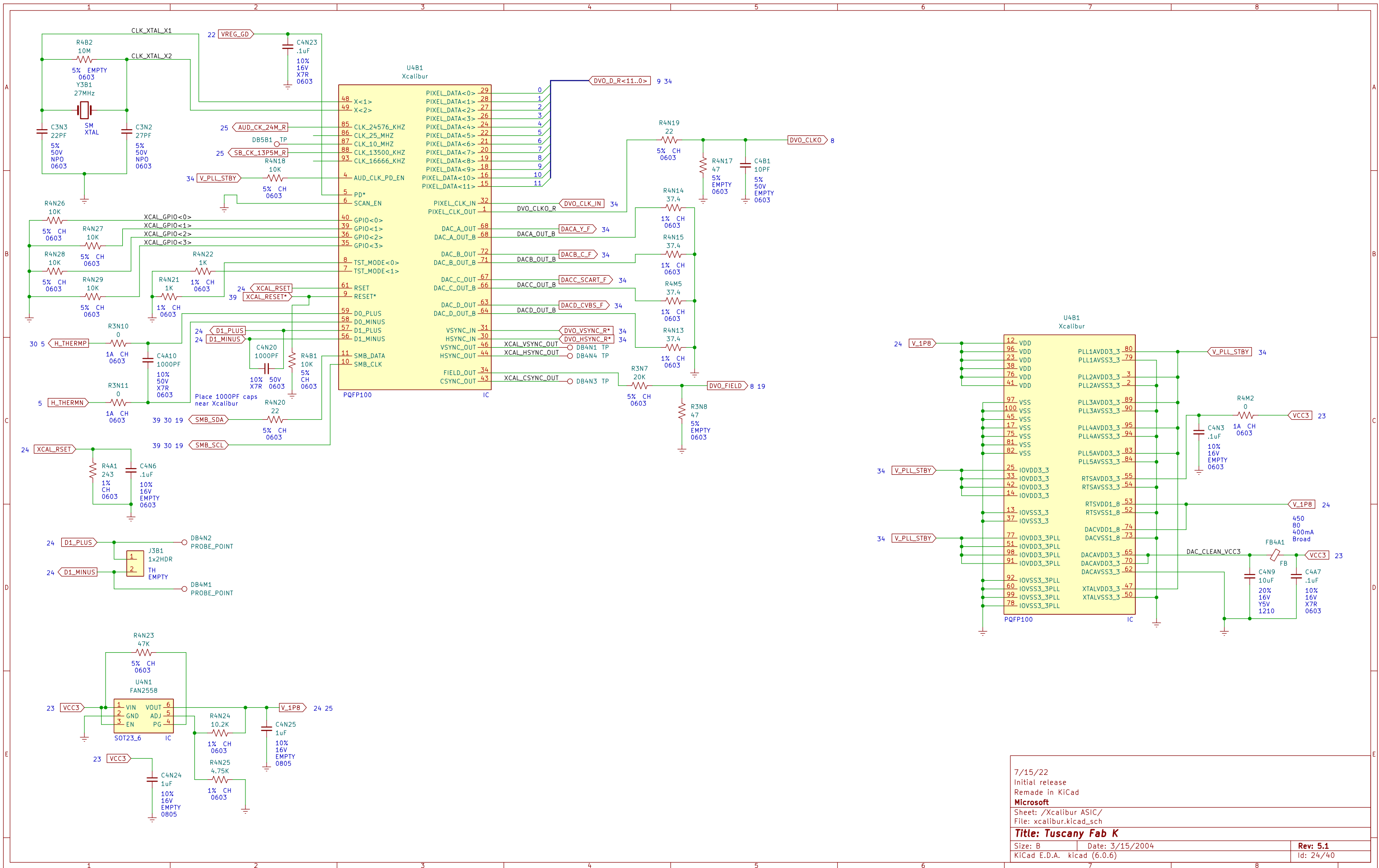

7/15/22
 Initial release
 Remade in KiCad
Microsoft
 Sheet: /Xcalibur ASIC/
 File: xcalibur.kicad_sch
Title: Tuscan Fab K
 Size: B Date: 3/15/2004 Rev: 5.1
 KiCad E.D.A. kicad (6.0.6) Id: 24/40

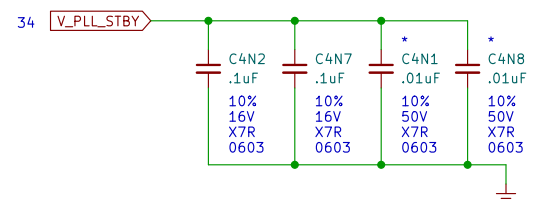
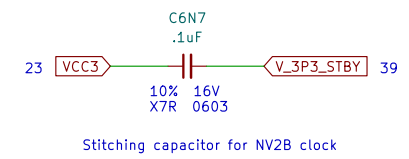
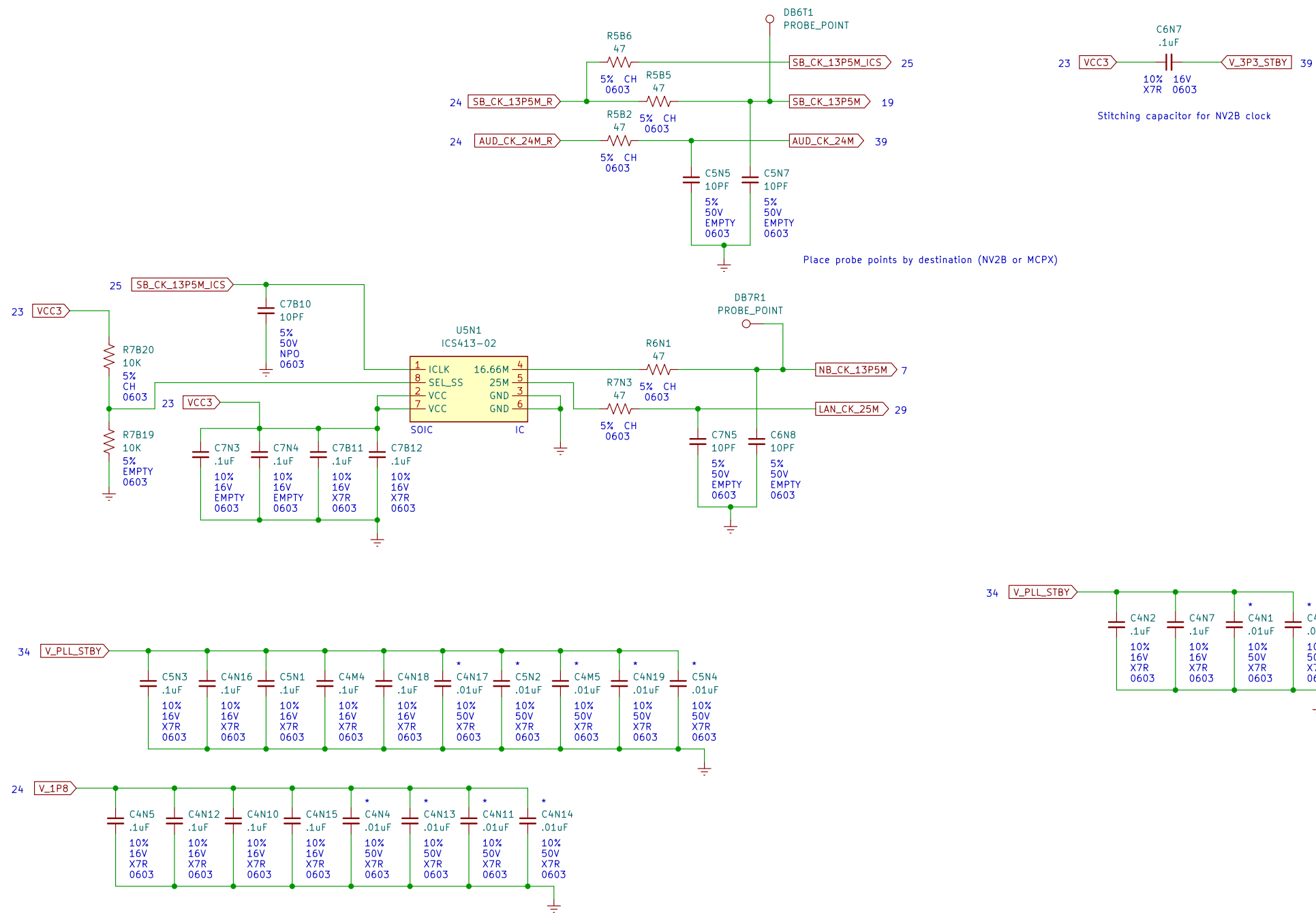

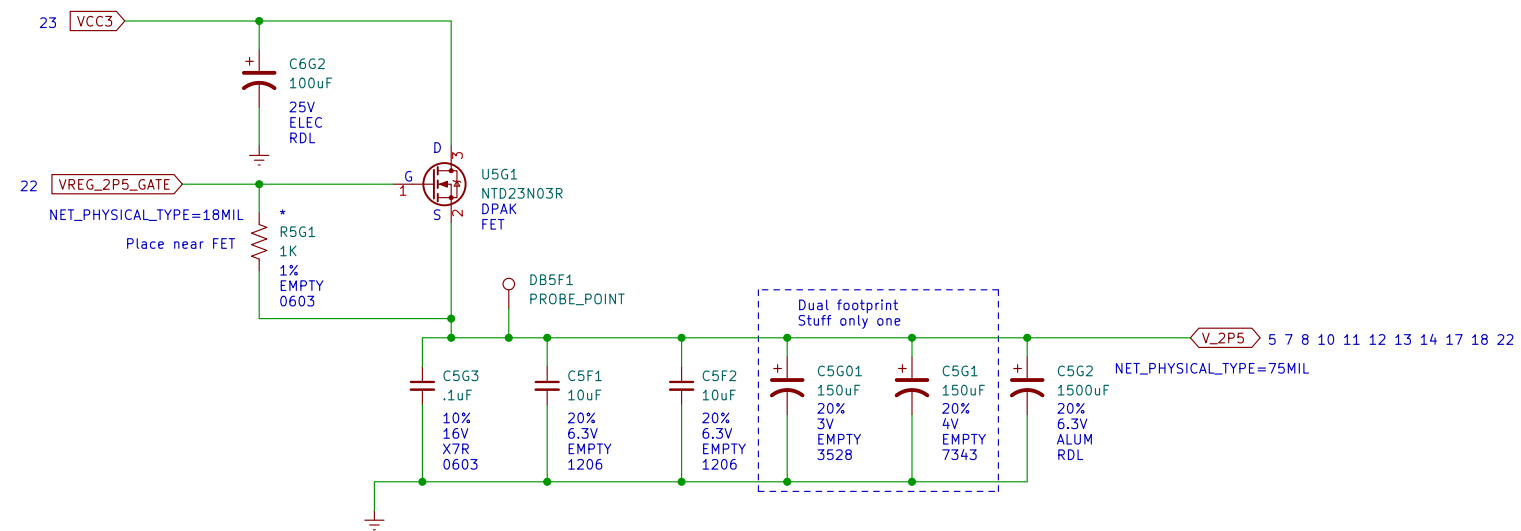
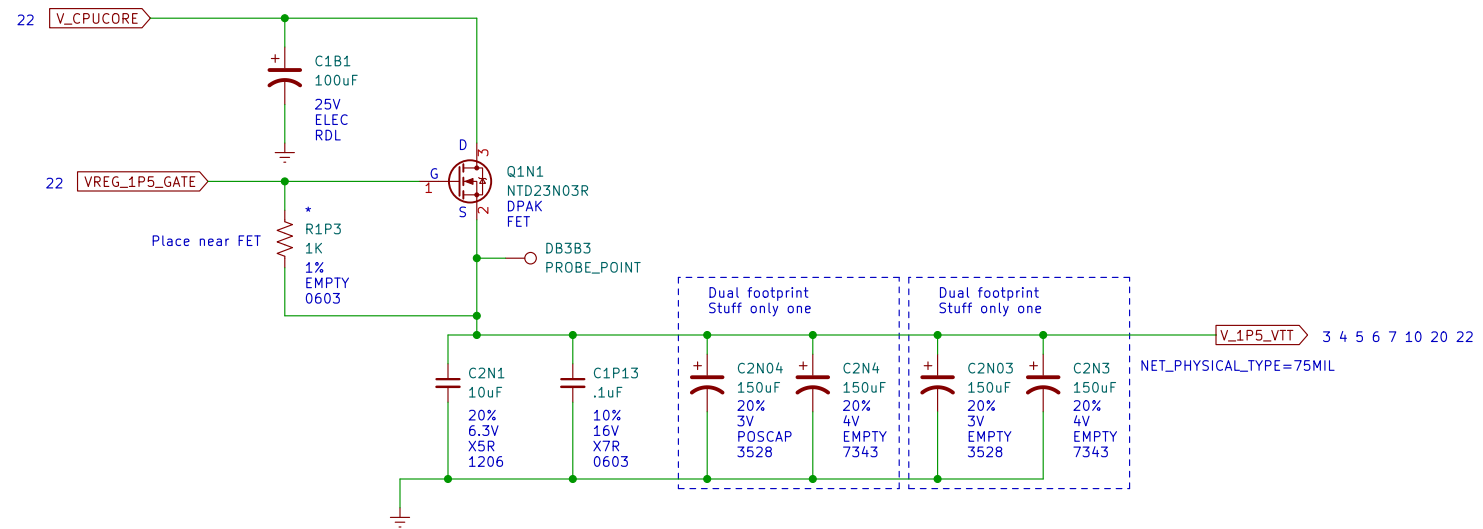

7/15/22		
Initial release		
Remade in KiCad		
Microsoft		
Sheet: /1.5VTT & 2.5V Regulators/		
File: 1-5vtt-2-5v-reg.kicad_sch		
Title: Tuscan Fab K		
Size: B	Date: 3/15/2004	Rev: 5.1
KiCad E.D.A. kicad (6.0.6)		Id: 26/40

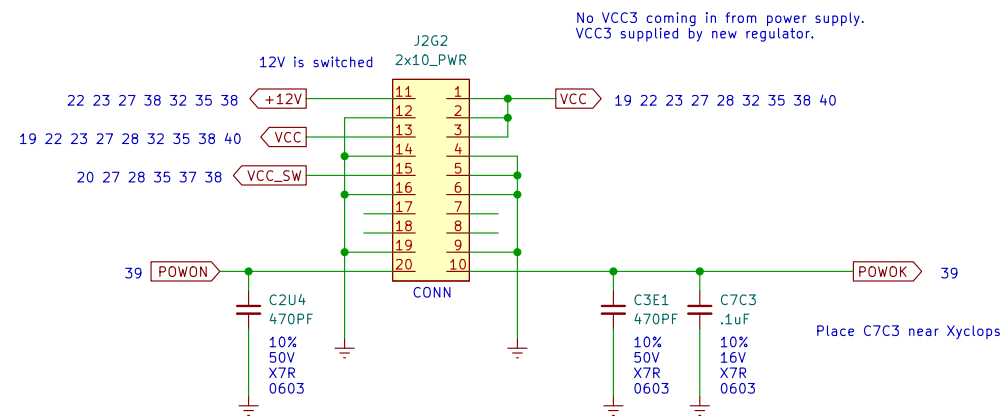

Power supply minimum load circuit

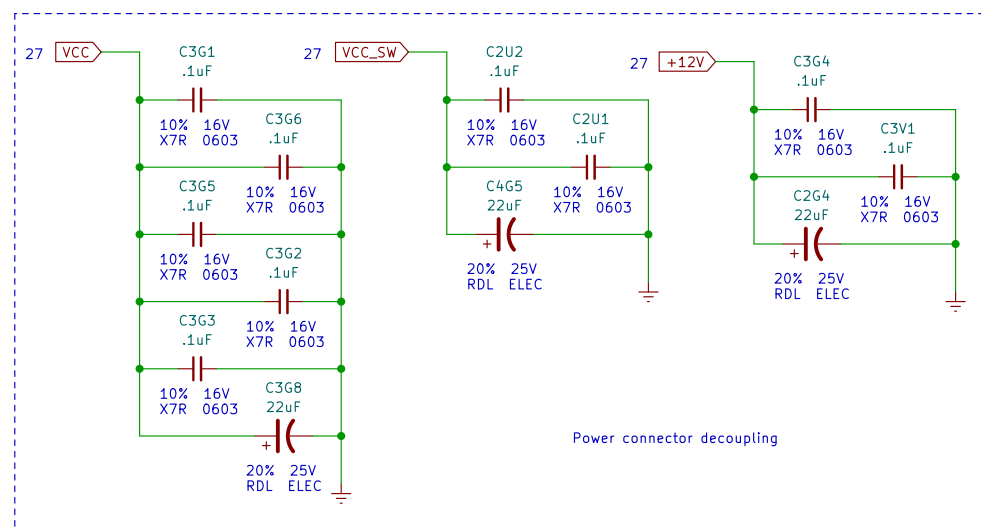
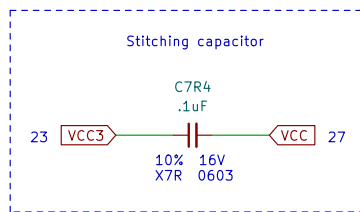
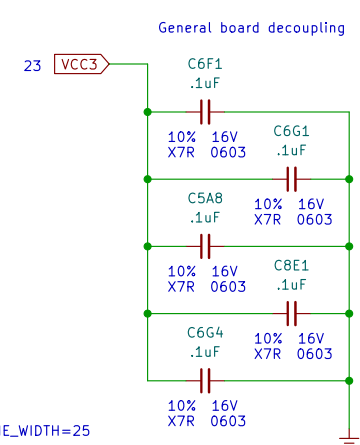
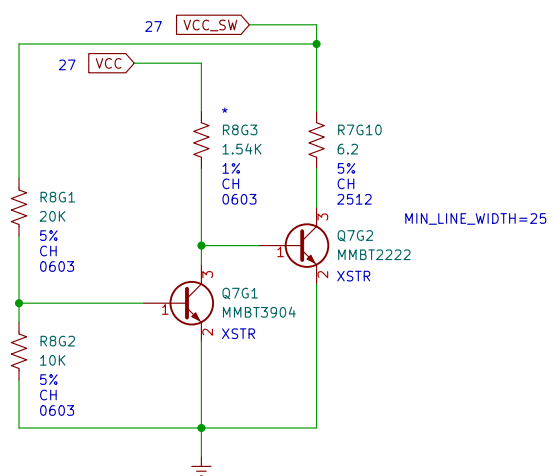
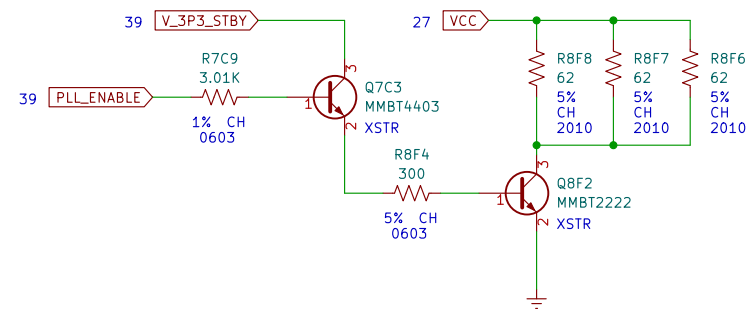

7/15/22		
Initial release		
Remade in KiCad		
Microsoft		
Sheet: /Power Connector & 5V Drain/		
File: power-connector-5v-drain.kicad_sch		
Title: Tuscany Fab K		
Size: B	Date: 3/15/2004	Rev: 5.1
KiCad E.D.A. kicad (6.0.6)		Id: 27/40

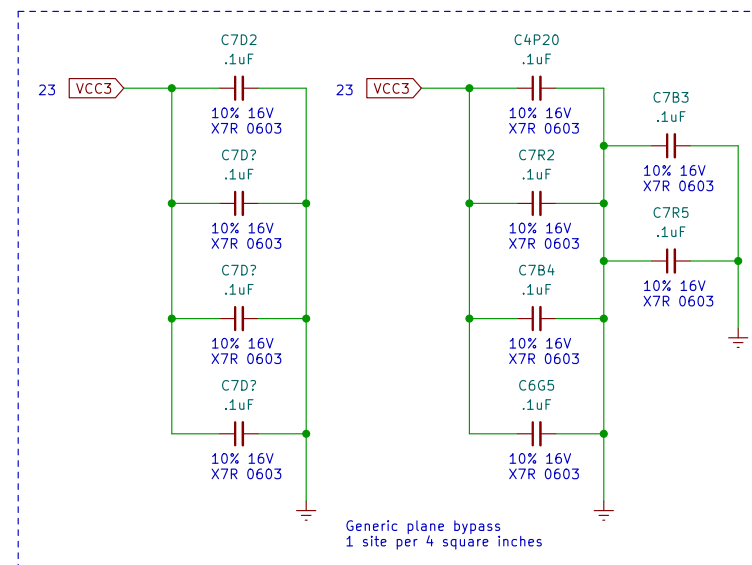
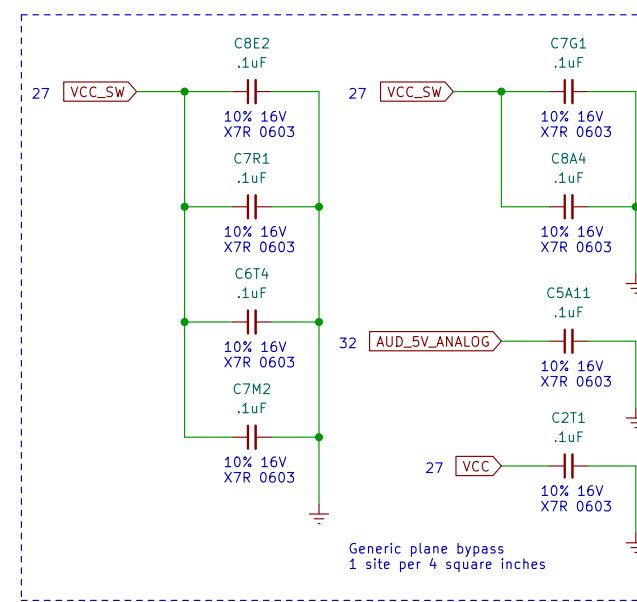
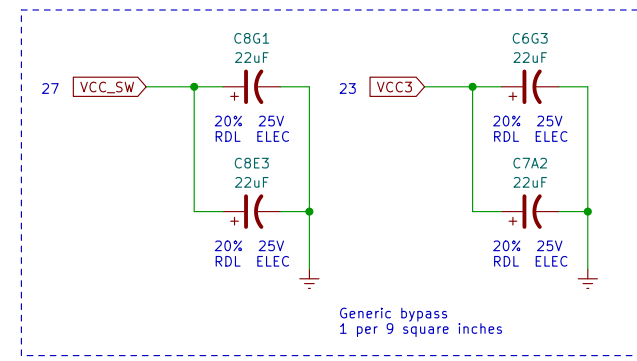
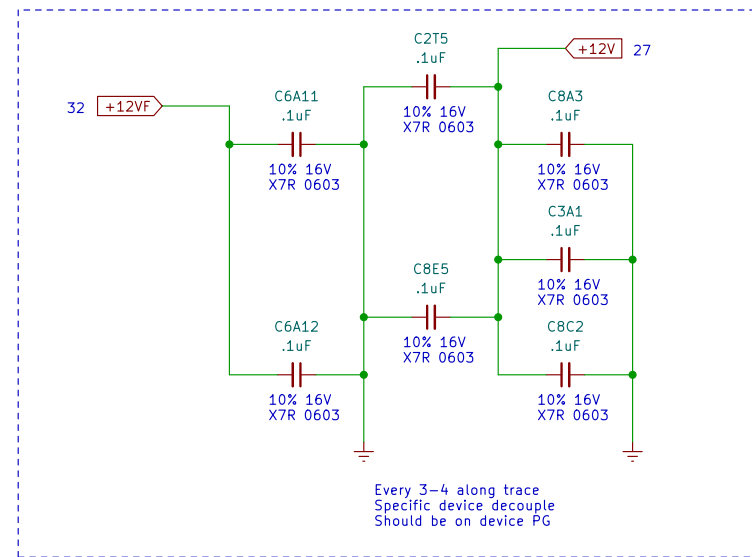

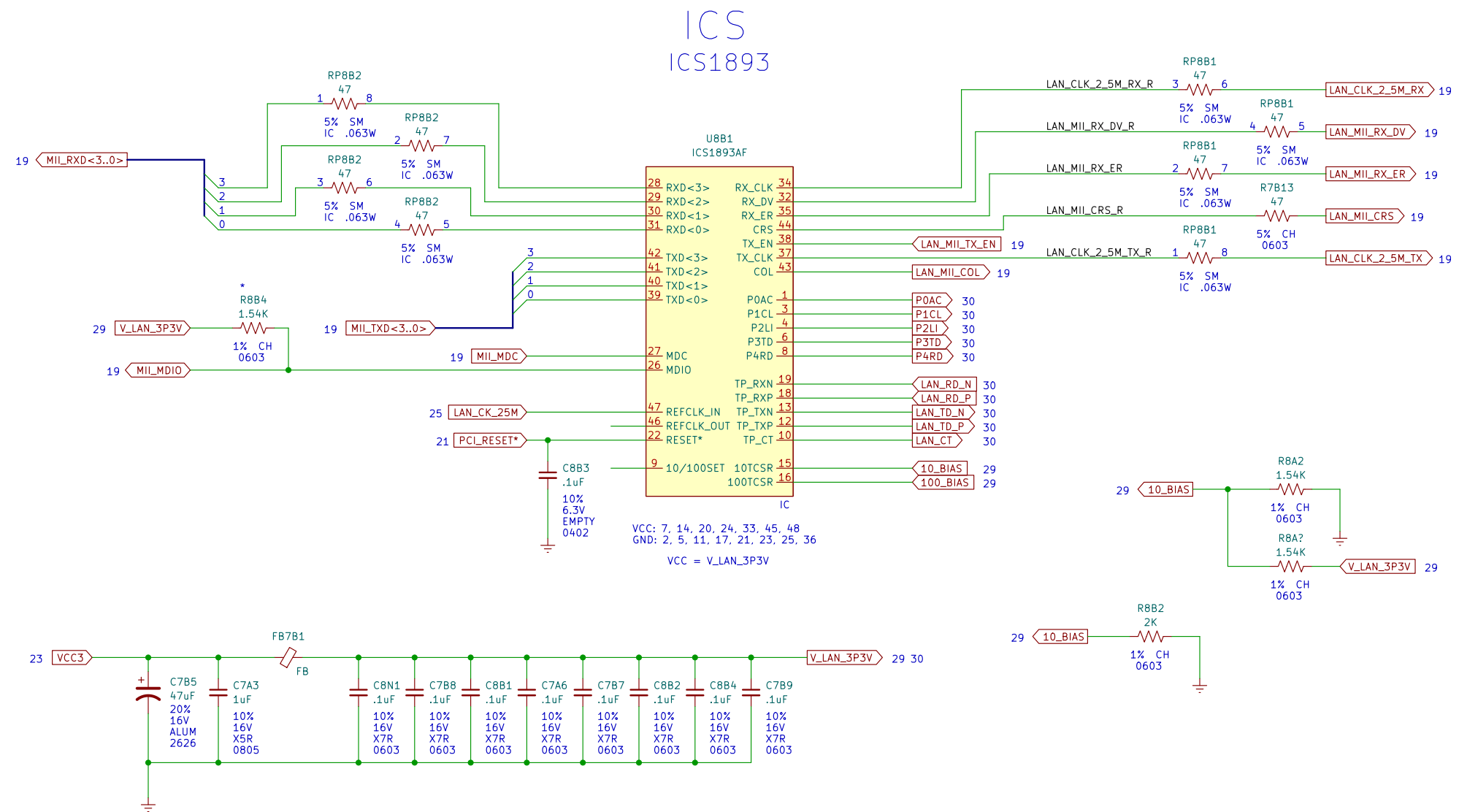

7/15/22
Initial release
Remade in KiCad
Microsoft
Sheet: /LAN ICS1893/
File: lan-ics1893.kicad_sch
Title: Tuscany Fab K

Size: B	Date: 3/15/2004	Rev: 5.1
KiCad E.D.A. kicad (6.0.6)		Id: 29/40

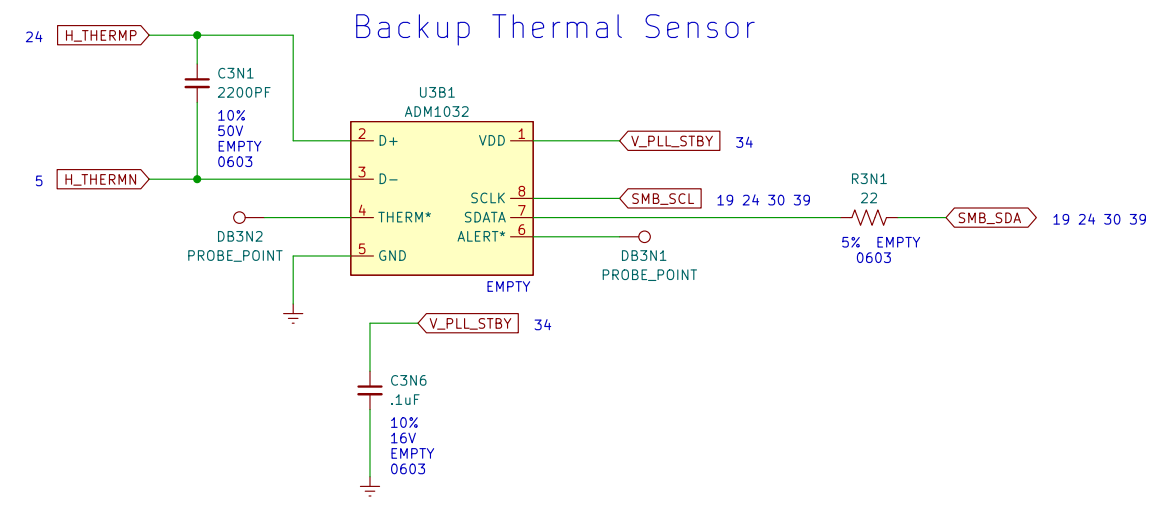
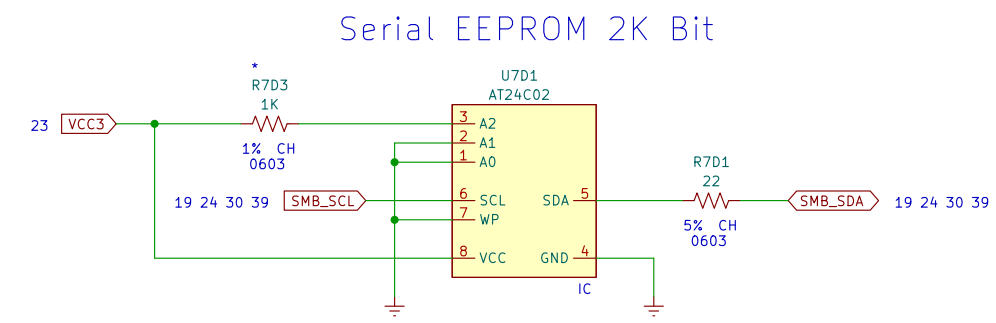
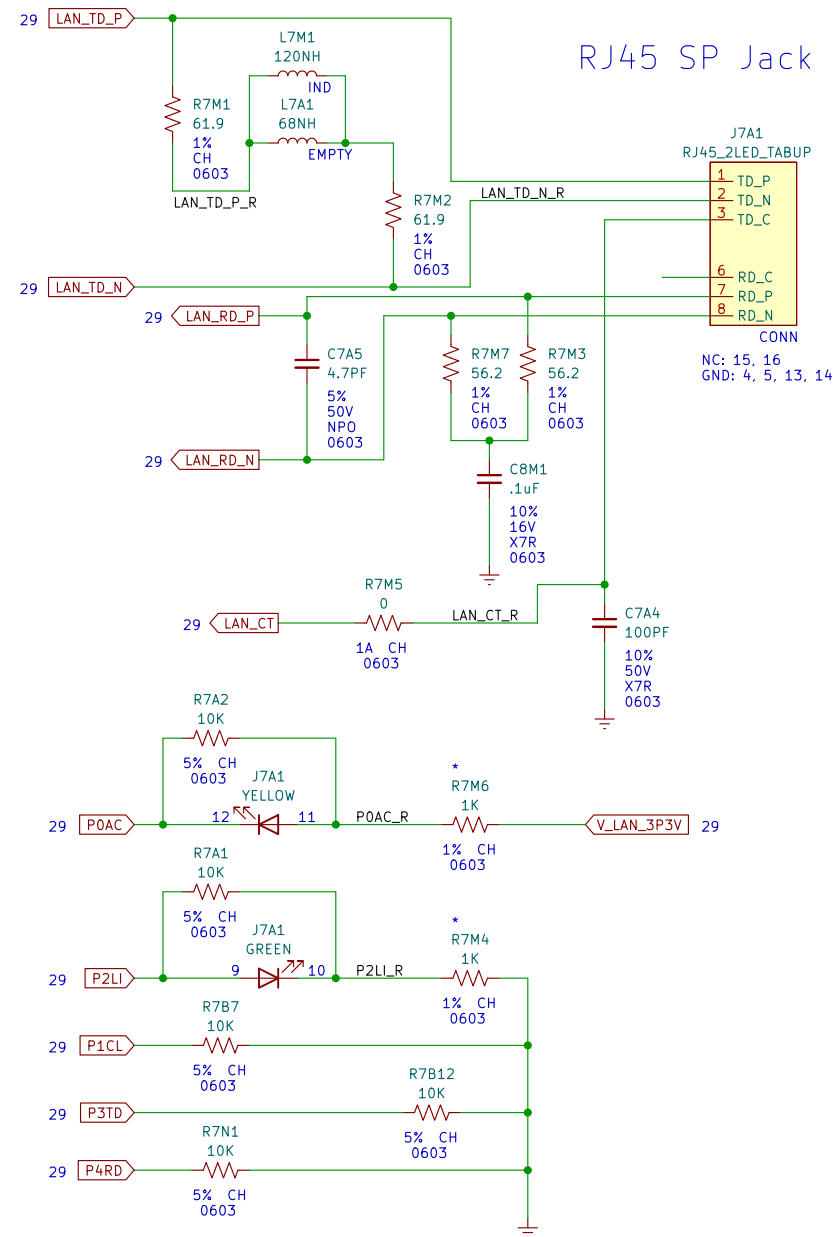

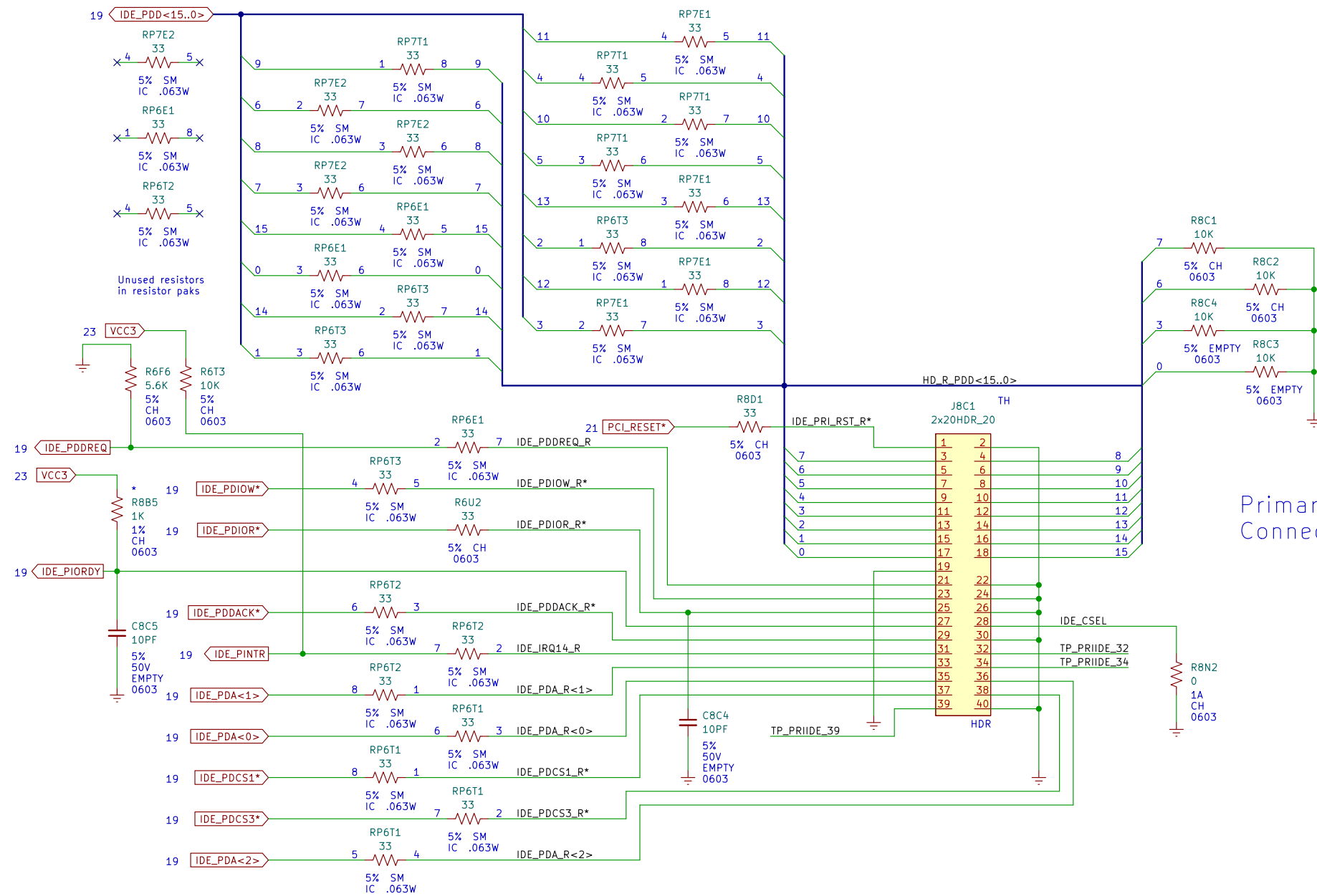

Primary IDE Connector

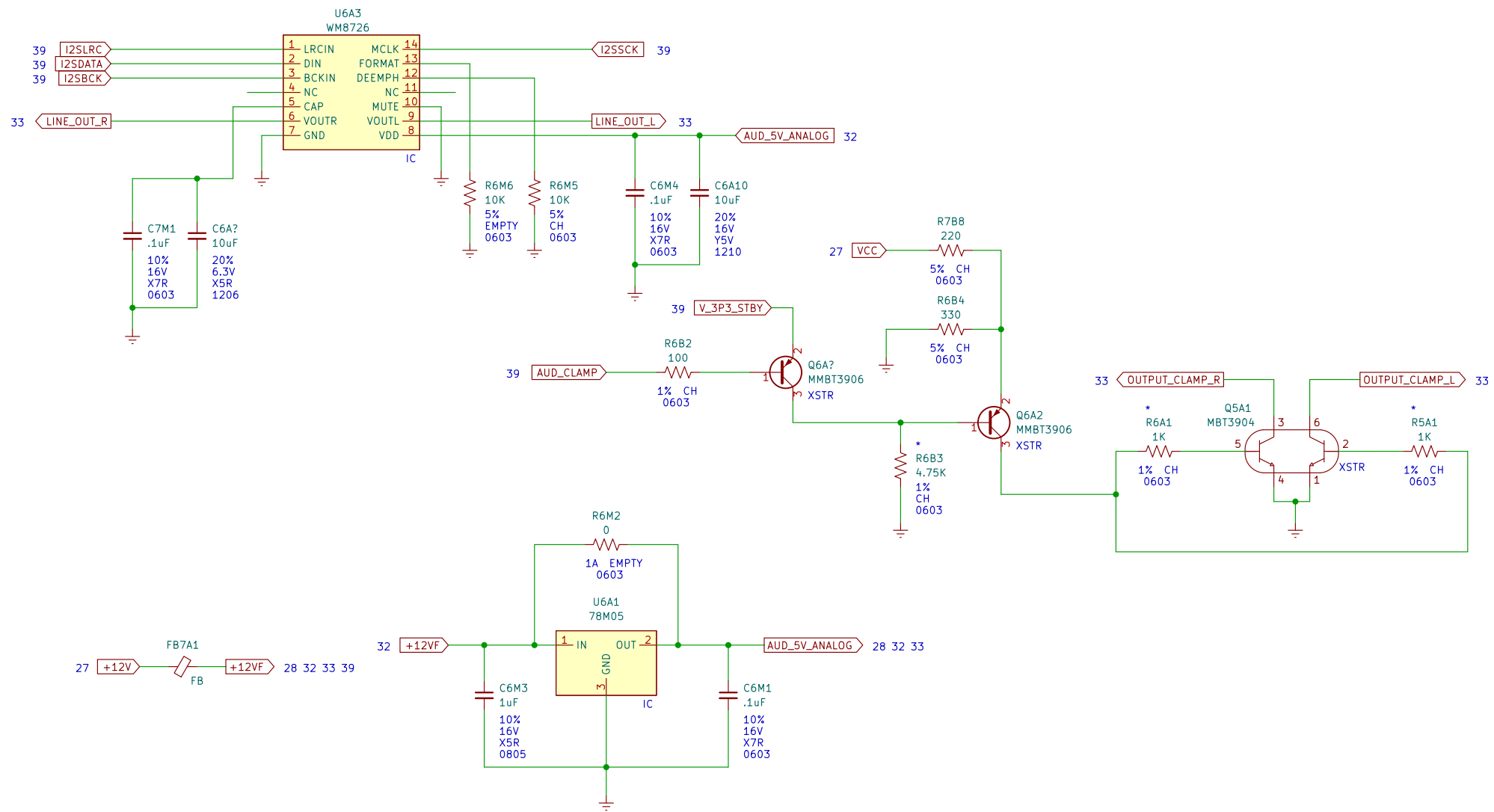

7/15/22
 Initial release
 Remade in KiCad
Microsoft
 Sheet: /Audio Codec & Voltage Regulator/
 File: aud-codec-reg.kicad_sch

Title: Tuscany Fab K

Size: B Date: 3/15/2004

Rev: 5.1
 Id: 32/40

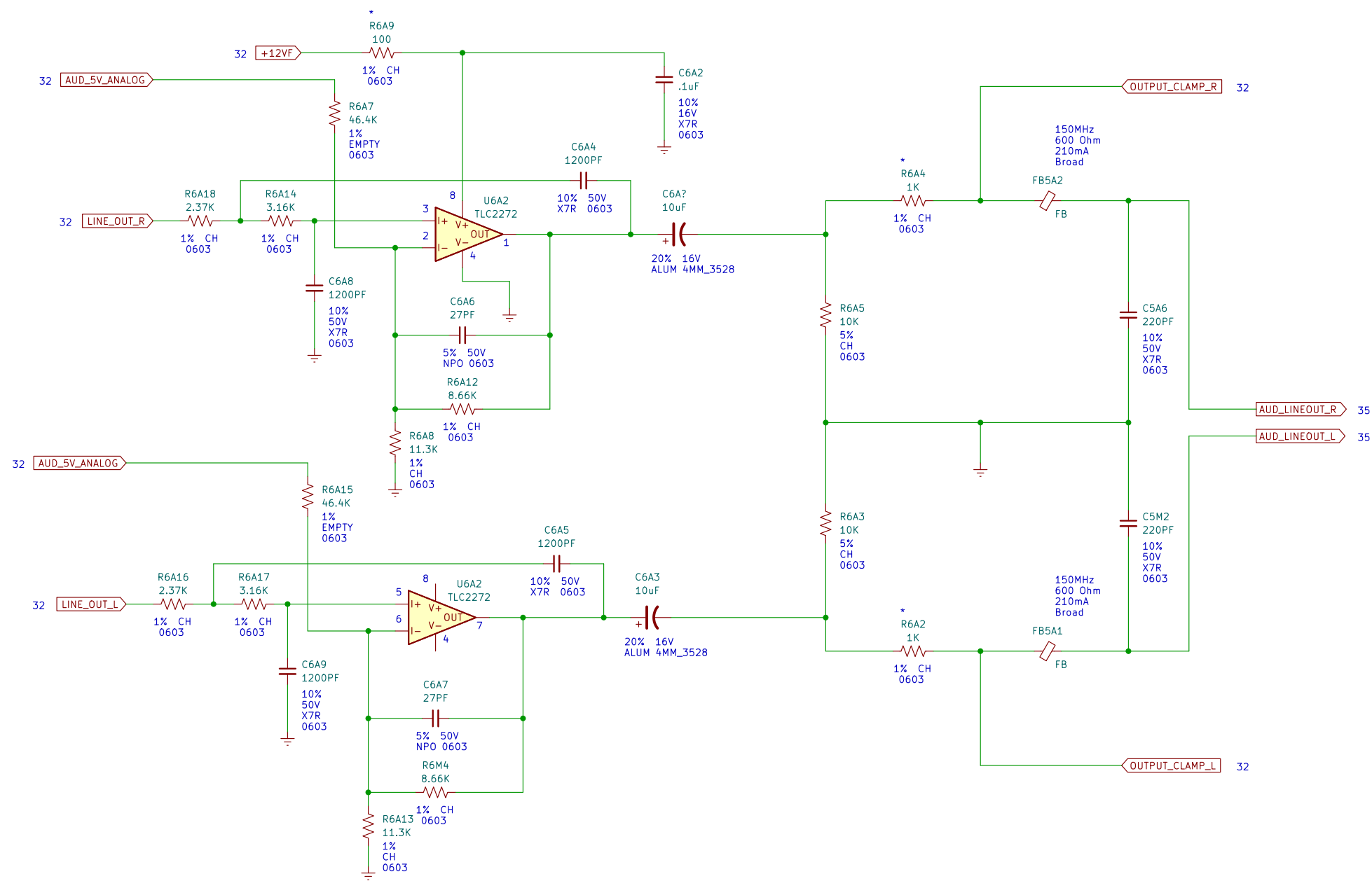

7/15/22		
Initial release		
Remade in KiCad		
Microsoft		
Sheet: /Audio Amplifier/		
File: aud-amp.kicad_sch		
Title: Tuscany Fab K		
Size: B	Date: 3/15/2004	Rev: 5.1
KiCad E.D.A. kicad (6.0.6)		Id: 33/40

DAC	TV Out	Scart	HDTV
A	Y (Luma)	G	Y
B	C (Chroma)	R	Pr
C	N/A	B	Pb
D	CVBS (Composite)	Composite	N/A

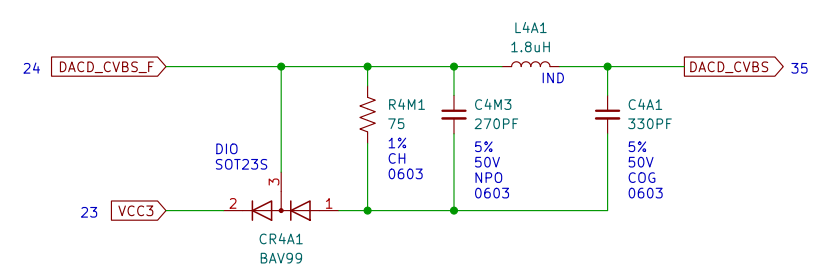
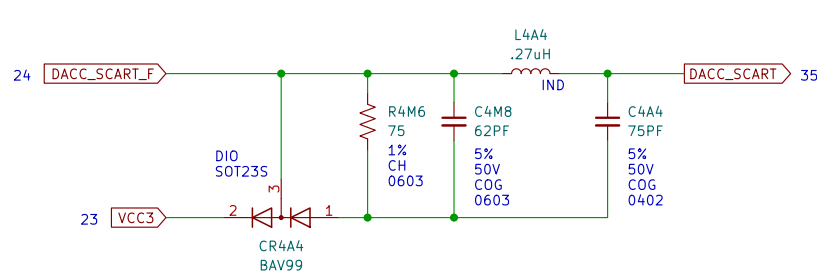
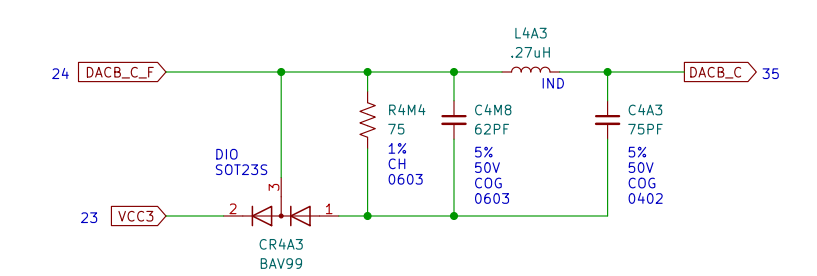
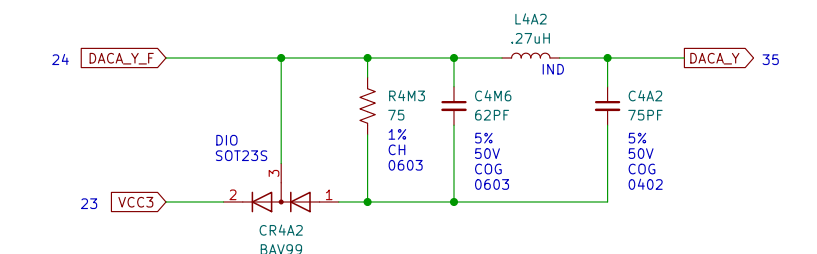
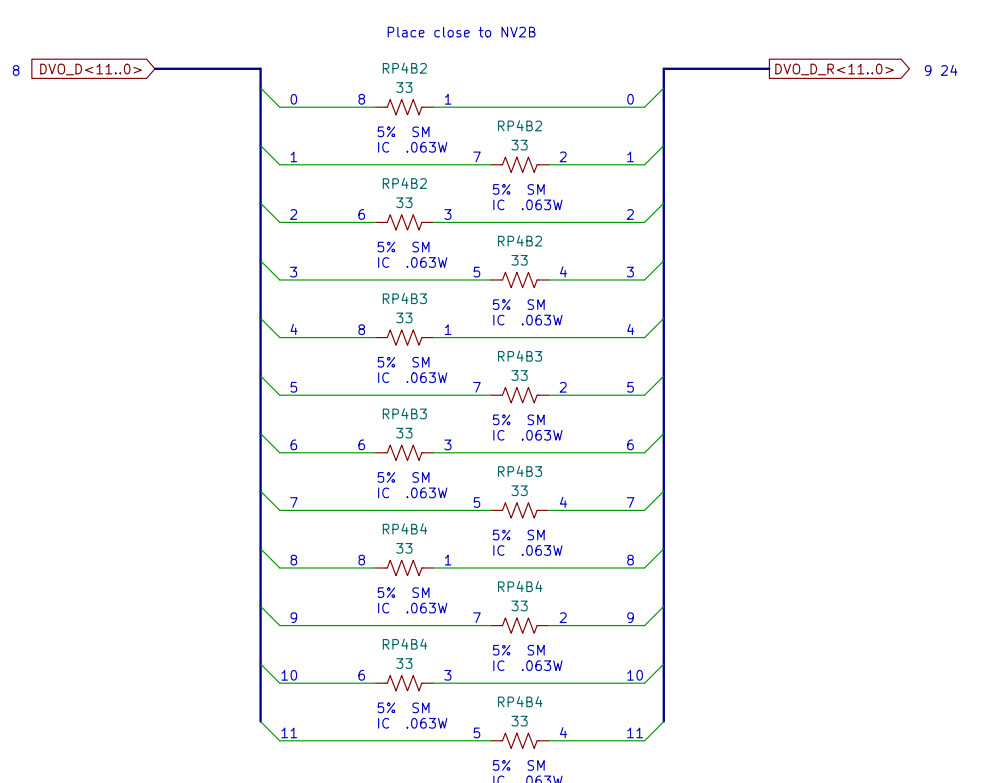
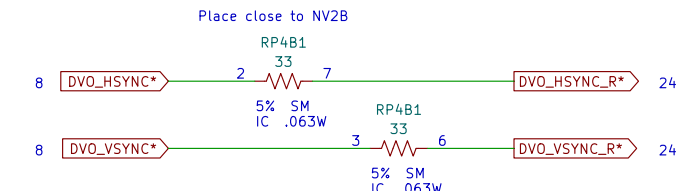
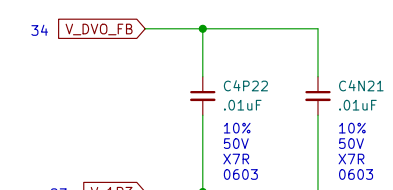
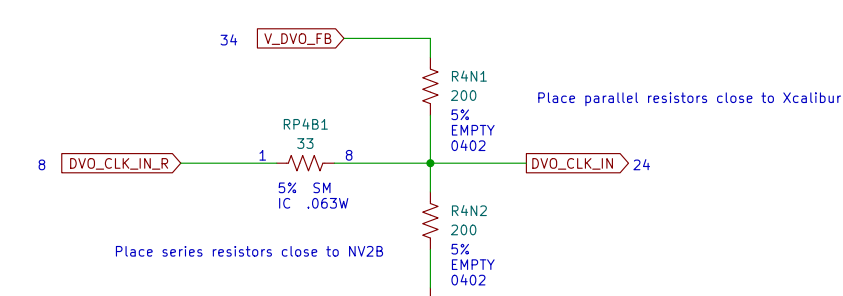
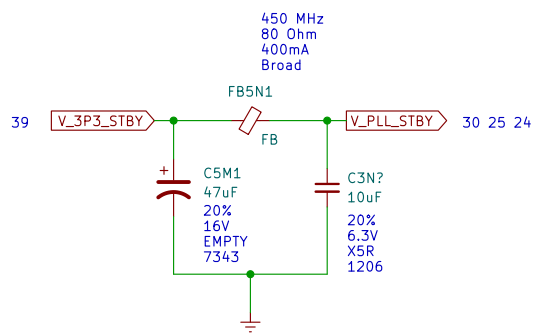
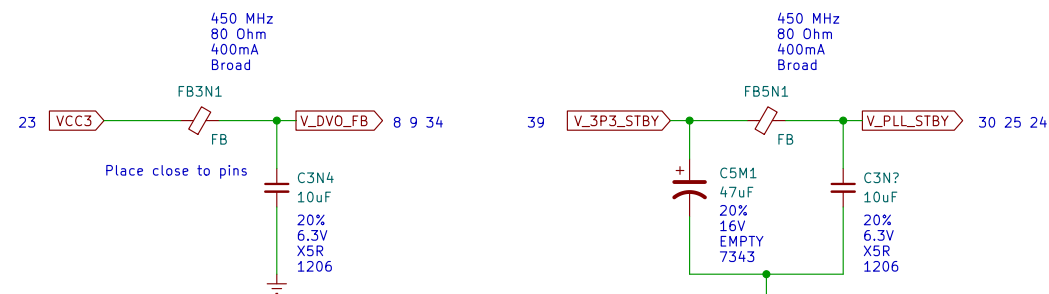

7/15/22
 Initial release
 Remade in KiCad
Microsoft
 Sheet: /Video Filtering & Miscellaneous/
 File: vid-filter-misc.kicad_sch
Title: Tuscany Fab K
 Size: B Date: 3/15/2004 Rev: 5.1
 KiCad E.D.A. kicad (6.0.6) Id: 34/40

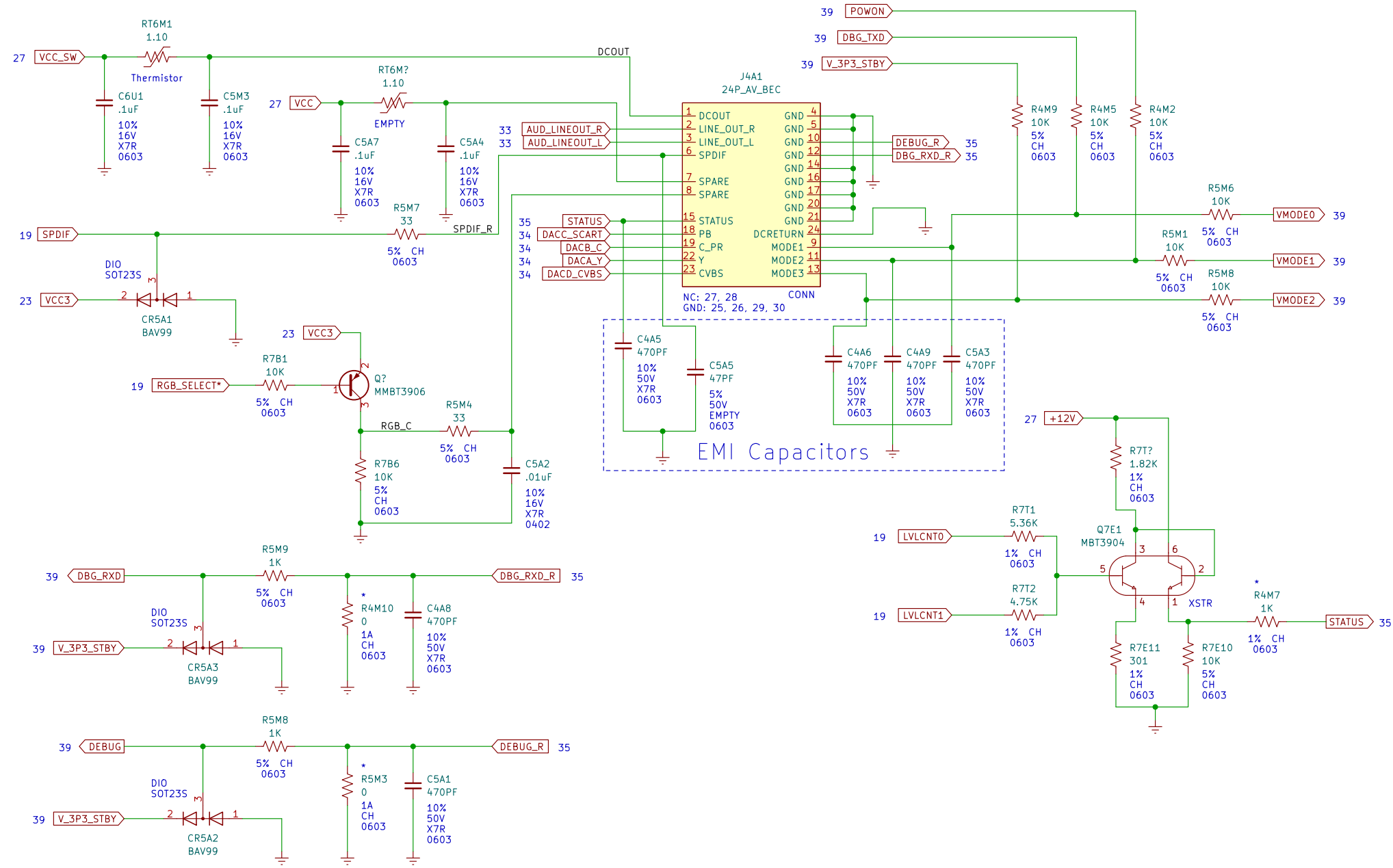

7/15/22
 Initial release
 Remade in KiCad
Microsoft
 Sheet: /AV Connector/
 File: av-conn.kicad_sch
Title: Tuscany Fab K

Size: B	Date: 3/15/2004	Rev: 5.1
KiCad E.D.A. kicad (6.0.6)		Id: 35/40

Labels

XA19177-001
LB8D1
Label

1375x250_TARGET

Intelligent serial number target

Mounting Holes

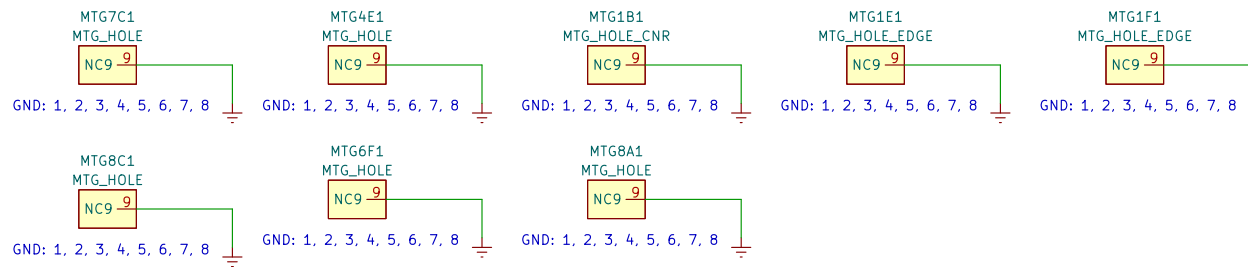

7/15/22

Initial release

Remade in KiCad

Microsoft

Sheet: /Labels & Mounting Holes/

File: labels-mounting.kicad_sch

Title: Tuscany Fab K

Size: B

Date: 3/15/2004

Rev: 5.1

KiCad E.D.A. kicad (6.0.6)

Id: 36/40

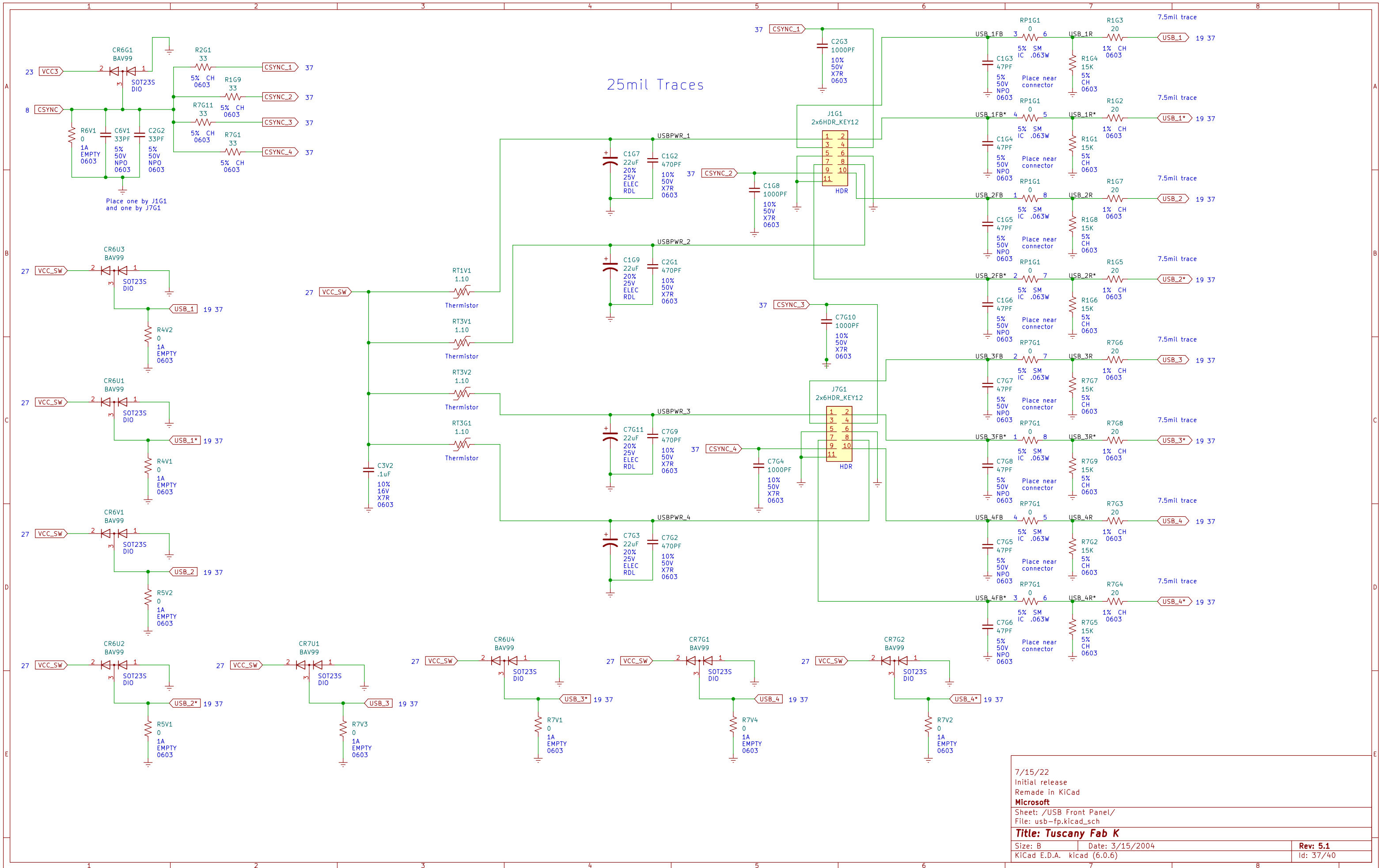

25mil Traces

7/15/22
 Initial release
 Remade in KiCad
 Microsoft
 Sheet: /USB Front Panel/
 File: usb-fp.kicad_sch
Title: Tuscan Fab K
 Size: B Date: 3/15/2004
 KiCad E.D.A. kicad (6.0.6) **Rev: 5.1**
 Id: 37/40

Fan Control

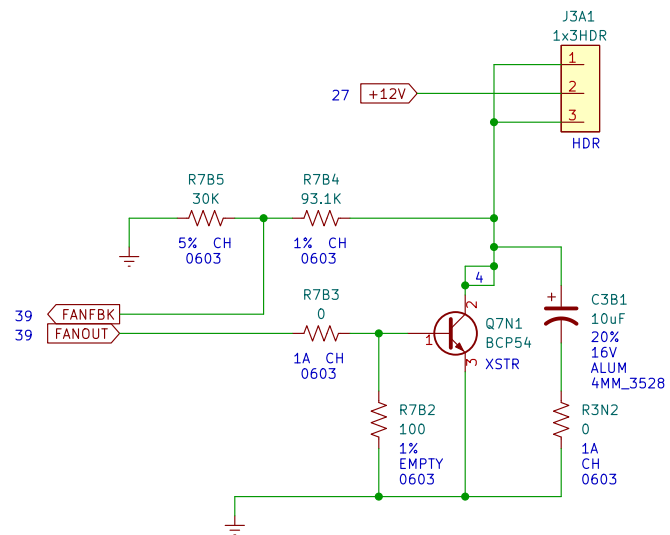

DVD Power Control

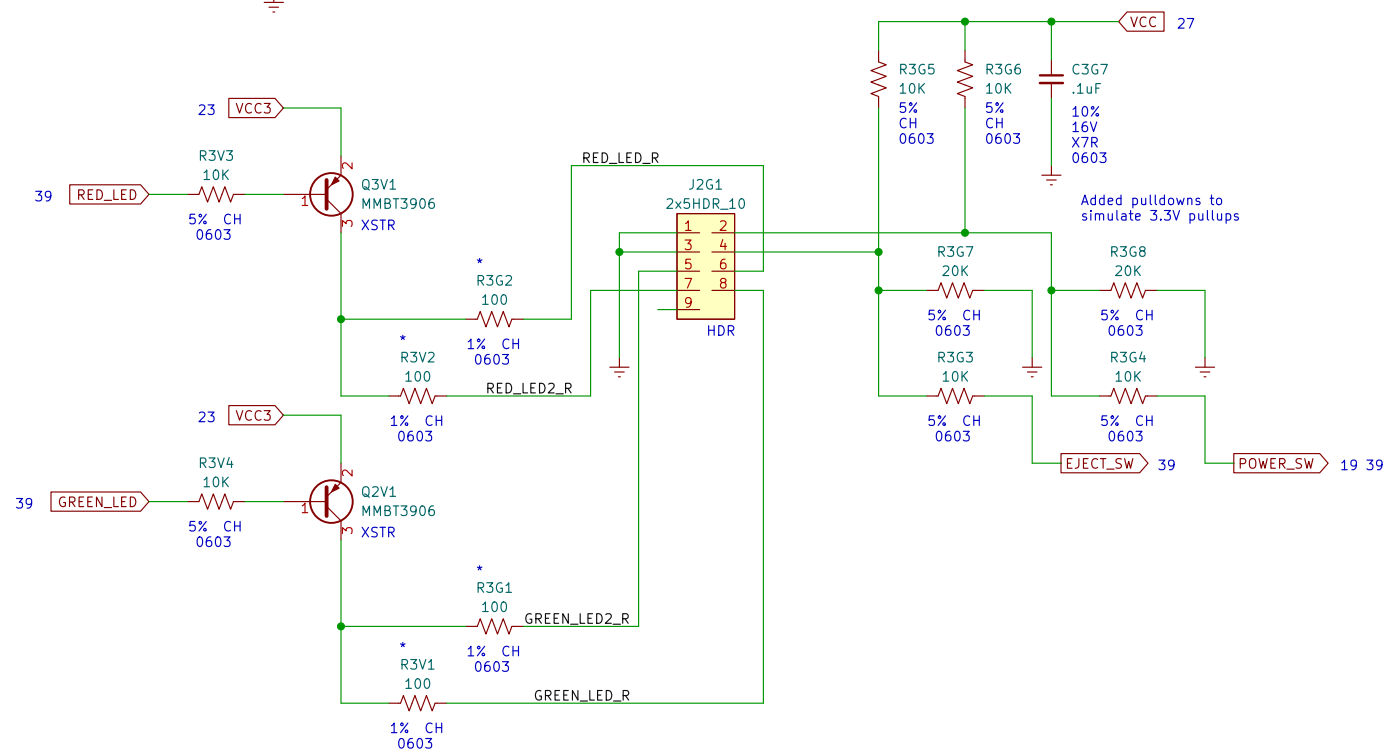
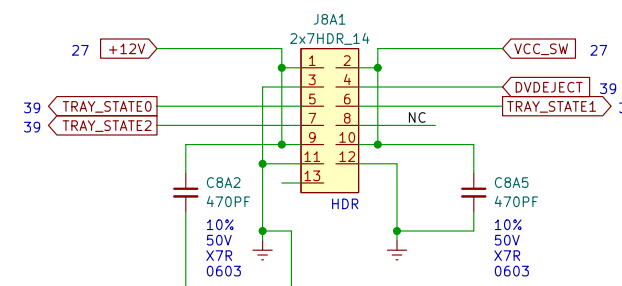

DVD Mounting Slots

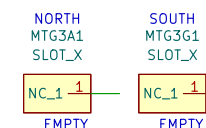

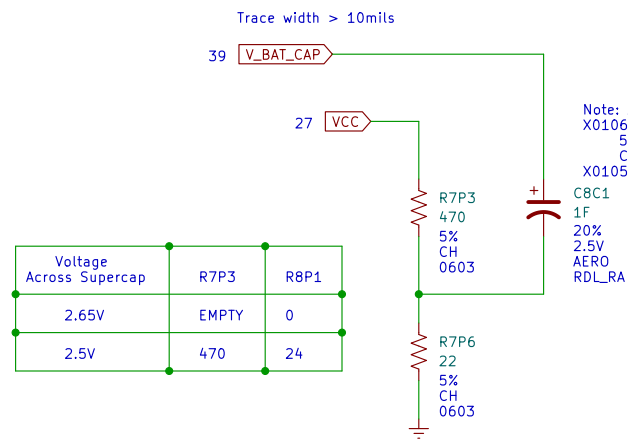

Note: 2 versions of this PCB exist.
 X01063-12X has 2 footprints (5mm and 3.5mm lead spacing)
 5mm is for tape-and-reel; 3.5mm is for bulk packaging
 C8C1 is 3.5mm; C8C3 is 5mm
 X01053-13X has 1 footprint (3.5mm only)

Voltage Across Supercap	R7P3	R8P1
2.65V	EMPTY	0
2.5V	470	24

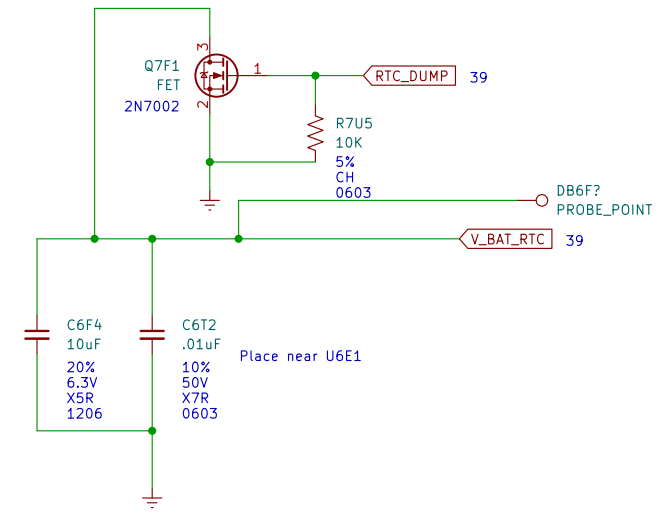

7/15/22
 Initial release
 Remade in KiCad
 Microsoft

Sheet: /Supercap/
 File: supercap.kicad_sch

Title: Tuscany Fab K

Size: B Date: 3/15/2004

Rev: 5.1
 Id: 40/40