

SYSTEM SCHEMATICS

A3000

MARCH, 1990

PN-314677-01

Commodore Business Machines, Inc.

1200 Wilson Drive, West Chester, Pennsylvania 19380 U.S.A.

Commodore makes no express or implied warranties with regard to the information contained herein. The information is made available solely on an as is basis, and the entire risk as to completeness, reliability, and accuracy is with the user. Commodore shall not be liable for any damages in connection with the use of the information contained herein. The listing of any available replacement part herein does not constitute in any case a recommendation, warranty or guaranty as to quality or suitability of such replacement part. Reproduction or use without express permission, of editorial or pictorial content, in any matter is prohibited.

This manual contains copyrighted and proprietary information. No part of this publication may be reproduced, stored in a retrieval system, or transmitted in any form or by any means, electronic, mechanical, photocopying, recording or otherwise, without the prior written permission of Commodore Electronics Limited.

Copyright © 1990 by Commodore Electronics Limited.
All rights reserved.

TABLE OF CONTENTS

- **SPECIFICATIONS**
- **PARTS LISTS**
- **SCHEMATICS**

A3000 FUNCTIONAL SPECIFICATION

INTRODUCTION

The A3000 is a cost reduced version of the A2500 personal computer. These cost reductions are achieved by extensive use of in house gate array technology, superior packaging and reduced power consumption. Visually, the A3000 is rendered similarly to a PS-2 computer; a low profile, small footprint case is used with a detached keyboard.

FEATURES

The objectives (features are:)

- 16 Mhz 68030 based CPU w/ 68881 optional (Optionally a 25 Mhz 68030 w/ 68882).
- 1 Meg of Chip Ram, expandable on board to 2 Meg. (32 bit access to CPU).
- 1 Meg of 32 bit wide Fast Ram, (expandable on board to 4 Meg).
- Kickstart in 32 bit ROM.
- Integral 3.5 inch Hard Disk & SCSI controller
- Facilities for 2 3.5 inch floppies.
- Real Time Clock.
- Facilities for on board de-interlacer/scan doubler.
- 4 100 pin Amiga slots, 2 of which are in line with PCAT slots, and one of which is in line with a new formfactor video slot.

The height and width of the A2000 casework has been replaced by a smaller footprint low profile case. The external floppy expansion disk connector has been replaced with the SCSI connector. The fan shall be less noisy than that on the A2000.

WHAT'S ADDED

The system now has a 68030 running with 32 bit wide RAM, and 32 bit wide ROM. An on board SCSI controller provides support for the optional internal hard disk drive, as well as a host of external peripherals such as optical disk drives, etc. 32 bit access to chip memory is provided.

CUSTOM CHIPS

The A3000 CPU will require the use of more custom integrated circuitry than any previous Commodore product. In addition to the 3 chip Amiga chipset, there are 5 new custom chips.

These include the system glue chip (FATGARY), a new expansion buss controller (FATBUSTER), a new ram controller with DMA support (RAMSEY), a new improved disk IO controller (SDMAC), and the flicker fixer gate array controller part (AMBER).

FATGARY

As the name implies, this chip is a larger version of the gary chip originally used in the A500 CPU design. Fat gary provides chip select and DASCK support for motherboard resources such as the 8520's, RTC, chipram, roms and SDMAC.

FATBUSTER

Fat Buster is a new, larger version of the A2000 chip of the same name. As before, it is responsible for expansion buss control and arbitration. However, the new buster also maps 32 bit 68030 memory cycles onto standard A2000 16 bit expansion buss cycles. Fat Buster also provides extensions to the standard A2000 16 bit buss protocol which allow full 32 bit address and data DMA to occur to and from expansion cards. Thus FATBUSTER allows us to mix and match existing 16 bit A2000 expansion cards, and a new 32 bit card format on the same expansion buss in a wholly compatible manner.

RAMSEY

RAMSEY is a dual function chip. It provides support for up to 4 megabytes of on board 32 bit wide ram, and provides address generation support for the super DMAC.

SDMAC

SDMAC is a new improved version of the 4701 series of disk & SCSI DMA controllers. SDMAC allows us to provide 32 bit Direct Disk DMA. It is felt that this will yield greatly improved system throughput for large applications, or disk intensive operating systems (read UNIX).

AMBER

Amber is the name of the flicker fixer controller gate array. This device, in conjunction with some specialized video memories, effectively provides a flicker fixer at low cost. This essential capability is to be option due to the sensitive cost of the specialized video drams required.

**Commodore International Spare Parts List
SHIPPING ASSEMBLIES**

Commodore part numbers are provided for reference only and do not indicate the availability of spare parts from Commodore. Industry standard parts (Resistors, Capacitors, Connectors) should be secured locally. Part number information may vary according to country, some parts may not be available in all countries.

| | | | |
|--|--|--|---|
| 313276-01 A3000 SHIPPING ASSY (USA) 16 MHZ | 363327-01 BOX PACKING CPU 320408-04 BAG FLAT 650 X 650 MM 318992-01 PACKING END CAP 318993-01 PACKING SPACER 318170-01 CARD READ THIS FIRST 316840-01 LABEL UPC 313278-02 MAIN ASSY (NTSC 110V) 16MHZ 903508-15 CORD POWER 327124-02 MOUSE ASSY 313323-02 KEYBOARD A3000 (U.S.) 363312-01 MANUAL A3000 QUICK CONNECT GUIDE 380426-01 FOAM NEOPOLEN SET (USE W/KEYBD) 251006-02 BAG FLAT 580MM X 350 MM (USE W/KEYBD) 324257-01 BAG DRYING AGENT 324252-07 TAPE ADHESIVE TRANSPARENT 50MM 315929-01 SOFTWARE SUB ASSY A3000 U.S. | 533000-01 A3000 SHIPPING ASSY (EUROPEAN) 16 MHZ | 363326-01 BOX PACKING CPU 320408-04 BAG FLAT 650 X 650 MM 318992-01 PACKING END CAP 324257-01 BAG DRYING AGENT 324252-07 TAPE ADHESIVE TRANSPARENT 50MM 313278-01 MAIN ASSY (PAL 220V) 16MHZ |
| 313276-02 A3000 SHIPPING ASSY (CANADA) 16 MHZ | 363327-01 BOX PACKING CPU 320408-04 BAG FLAT 650 X 650 MM 318992-01 PACKING END CAP 318993-01 PACKING SPACER 318170-01 CARD READ THIS FIRST 316840-01 LABEL UPC 313278-02 MAIN ASSY (NTSC 110V) 16MHZ 903508-15 CORD POWER 327124-02 MOUSE ASSY 313323-02 KEYBOARD A3000 (U.S.) 363312-01 MANUAL A3000 QUICK CONNECT GUIDE 380426-01 FOAM NEOPOLEN SET (USE W/KEYBD) 251006-02 BAG FLAT 580MM X 350 MM (USE W/KEYBD) 324257-01 BAG DRYING AGENT 324252-07 TAPE ADHESIVE TRANSPARENT 50MM 315929-02 SOFTWARE SUB ASSY A3000 CANADA | 533000-02 A3000 SHIPPING ASSY (EUROPEAN) 25 MHZ | 363326-01 BOX PACKING CPU 320408-04 BAG FLAT 650 X 650 MM 318992-01 PACKING END CAP 324257-01 BAG DRYING AGENT 324252-07 TAPE ADHESIVE TRANSPARENT 50MM 313278-03 MAIN ASSY (PAL 220V) 25MHZ |
| 313276-03 A3000 SHIPPING ASSY (USA) 25 MHZ | 363327-01 BOX PACKING CPU 320408-04 BAG FLAT 650 X 650 MM 318992-01 PACKING END CAP 318993-01 PACKING SPACER 318170-01 CARD READ THIS FIRST 316840-01 LABEL UPC 313278-04 MAIN ASSY (NTSC 110V) 25MHZ 903508-15 CORD POWER 327124-02 MOUSE ASSY 313323-02 KEYBOARD A3000 (U.S.) 363312-01 MANUAL A3000 QUICK CONNECT GUIDE 380426-01 FOAM NEOPOLEN SET (USE W/KEYBD) 251006-02 BAG FLAT 580MM X 350 MM (USE W/KEYBD) 324257-01 BAG DRYING AGENT 324252-07 TAPE ADHESIVE TRANSPARENT 50MM 315929-01 SOFTWARE SUB ASSY A3000 U.S. | 313323-01 KEYBOARD ASSY A3000 U.K. | 312458-01 HOUSING KEYBOARD TOP 312375-01 HOUSING KEYBOARD BOTTOM 312715-01 PCB ASSY KEYBOARD U.K. 380130-01 FOOT KEYBOARD ADJUSTABLE 380131-01 PLATE SPRING 907272-06 WASHER FLAT 4.3 MM 906883-04 SCREW PAN HEAD S.T. 2.9 X 9.5MM 906805-03 SCREW FLAT HEAD S.T. 2.9 X 9.5MM 380129-01 FOOT PLASTIC 380018-05 CABLE KEYBOARD ASSY II HITEK |
| 313276-04 A3000 SHIPPING ASSY (CANADA) 25 MHZ | 363327-01 BOX PACKING CPU 320408-04 BAG FLAT 650 X 650 MM 318992-01 PACKING END CAP 318993-01 PACKING SPACER 318170-01 CARD READ THIS FIRST 316840-01 LABEL UPC 313278-04 MAIN ASSY (NTSC 110V) 25MHZ 903508-15 CORD POWER 327124-02 MOUSE ASSY 313323-02 KEYBOARD A3000 (U.S.) 363312-01 MANUAL A3000 QUICK CONNECT GUIDE 380426-01 FOAM NEOPOLEN SET (USE W/KEYBD) 251006-02 BAG FLAT 580MM X 350 MM (USE W/KEYBD) 324257-01 BAG DRYING AGENT 324252-07 TAPE ADHESIVE TRANSPARENT 50MM 315929-02 SOFTWARE SUB ASSY A3000 CANADA | 313323-02 KEYBOARD ASSY A3000 U.S. | 312458-01 HOUSING KEYBOARD TOP 312375-01 HOUSING KEYBOARD BOTTOM 312715-02 PCB ASSY KEYBOARD U.S. 380130-01 FOOT KEYBOARD ADJUSTABLE 380131-01 PLATE SPRING 907272-06 WASHER FLAT 4.3 MM 906883-04 SCREW PAN HEAD S.T. 2.9 X 9.5MM 906805-03 SCREW FLAT HEAD S.T. 2.9 X 9.5MM 380129-01 FOOT PLASTIC 380018-06 CABLE KEYBOARD ASSY II TOROID |
| | | 313323-03 KEYBOARD ASSY A3000 GERMANY | 312458-01 HOUSING KEYBOARD TOP 312375-01 HOUSING KEYBOARD BOTTOM 312715-03 PCB ASSY KEYBOARD GERMANY 380130-01 FOOT KEYBOARD ADJUSTABLE 380131-01 PLATE SPRING 907272-06 WASHER FLAT 4.3 MM 906883-04 SCREW PAN HEAD S.T. 2.9 X 9.5MM 906805-03 SCREW FLAT HEAD S.T. 2.9 X 9.5MM 380129-01 FOOT PLASTIC 380018-05 CABLE KEYBOARD ASSY II HITEK |
| | | 313323-04 KEYBOARD ASSY A3000 ITALY | 312458-01 HOUSING KEYBOARD TOP 312375-01 HOUSING KEYBOARD BOTTOM 312715-04 PCB ASSY KEYBOARD ITALY 380130-01 FOOT KEYBOARD ADJUSTABLE 380131-01 PLATE SPRING 907272-06 WASHER FLAT 4.3 MM 906883-04 SCREW PAN HEAD S.T. 2.9 X 9.5MM 906805-03 SCREW FLAT HEAD S.T. 2.9 X 9.5MM 380129-01 FOOT PLASTIC 380018-05 CABLE KEYBOARD ASSY II HITEK |
| | | 313323-05 KEYBOARD ASSY A3000 FRANCE | 312458-01 HOUSING KEYBOARD TOP 312375-01 HOUSING KEYBOARD BOTTOM 312715-05 PCB ASSY KEYBOARD FRANCE 380130-01 FOOT KEYBOARD ADJUSTABLE 380131-01 PLATE SPRING 907272-06 WASHER FLAT 4.3 MM 906883-04 SCREW PAN HEAD S.T. 2.9 X 9.5MM 906805-03 SCREW FLAT HEAD S.T. 2.9 X 9.5MM 380129-01 FOOT PLASTIC 380018-05 CABLE KEYBOARD ASSY II HITEK |

Commodore International Spare Parts List SHIPPING ASSEMBLIES

Commodore part numbers are provided for reference only and do not indicate the availability of spare parts from Commodore. Industry standard parts (Resistors, Capacitors, Connectors) should be secured locally. Part number information may vary according to country, some parts may not be available in all countries.

| | | | |
|--|--|--|--|
| 313276-01 A3000 SHIPPING ASSY (USA) 16 MHZ | 363327-01 BOX PACKING CPU 320408-04 BAG FLAT 650 X 650 MM 318992-01 PACKING END CAP 318993-01 PACKING SPACER 318170-01 CARD READ THIS FIRST 316840-01 LABEL UPC 313278-02 MAIN ASSY (NTSC 110V) 16MHZ 903508-15 CORD POWER 327124-02 MOUSE ASSY 313323-02 KEYBOARD A3000 (U.S.) 363312-01 MANUAL A3000 QUICK CONNECT GUIDE 380426-01 FOAM NEOPOLEN SET (USE W/KEYBD) 251006-02 BAG FLAT 580MM X 350 MM (USE W/KEYBD) 324257-01 BAG DRYING AGENT 324252-07 TAPE ADHESIVE TRANSPARENT 50MM 315929-01 SOFTWARE SUB ASSY A3000 U.S. | 533000-01 A3000 SHIPPING ASSY (EUROPEAN) 16 MHZ | 363326-01 BOX PACKING CPU 320408-04 BAG FLAT 650 X 650 MM 318992-01 PACKING END CAP 324257-01 BAG DRYING AGENT 324252-07 TAPE ADHESIVE TRANSPARENT 50MM 313278-01 MAIN ASSY (PAL 220V) 16MHZ |
| 313276-02 A3000 SHIPPING ASSY (CANADA) 16 MHZ | 363327-01 BOX PACKING CPU 320408-04 BAG FLAT 650 X 650 MM 318992-01 PACKING END CAP 318993-01 PACKING SPACER 318170-01 CARD READ THIS FIRST 316840-01 LABEL UPC 313278-02 MAIN ASSY (NTSC 110V) 16MHZ 903508-15 CORD POWER 327124-02 MOUSE ASSY 313323-02 KEYBOARD A3000 (U.S.) 363312-01 MANUAL A3000 QUICK CONNECT GUIDE 380426-01 FOAM NEOPOLEN SET (USE W/KEYBD) 251006-02 BAG FLAT 580MM X 350 MM (USE W/KEYBD) 324257-01 BAG DRYING AGENT 324252-07 TAPE ADHESIVE TRANSPARENT 50MM 315929-02 SOFTWARE SUB ASSY A3000 CANADA | 533000-02 A3000 SHIPPING ASSY (EUROPEAN) 25 MHZ | 363326-01 BOX PACKING CPU 320408-04 BAG FLAT 650 X 650 MM 318992-01 PACKING END CAP 324257-01 BAG DRYING AGENT 324252-07 TAPE ADHESIVE TRANSPARENT 50MM 313278-03 MAIN ASSY (PAL 220V) 25MHZ |
| 313276-03 A3000 SHIPPING ASSY (USA) 25 MHZ | 363327-01 BOX PACKING CPU 320408-04 BAG FLAT 650 X 650 MM 318992-01 PACKING END CAP 318993-01 PACKING SPACER 318170-01 CARD READ THIS FIRST 316840-01 LABEL UPC 313278-04 MAIN ASSY (NTSC 110V) 25MHZ 903508-15 CORD POWER 327124-02 MOUSE ASSY 313323-02 KEYBOARD A3000 (U.S.) 363312-01 MANUAL A3000 QUICK CONNECT GUIDE 380426-01 FOAM NEOPOLEN SET (USE W/KEYBD) 251006-02 BAG FLAT 580MM X 350 MM (USE W/KEYBD) 324257-01 BAG DRYING AGENT 324252-07 TAPE ADHESIVE TRANSPARENT 50MM 315929-01 SOFTWARE SUB ASSY A3000 U.S. | 313323-01 KEYBOARD ASSY A3000 U.K. | 312458-01 HOUSING KEYBOARD TOP 312375-01 HOUSING KEYBOARD BOTTOM 312715-01 PCB ASSY KEYBOARD U.K. 380130-01 FOOT KEYBOARD ADJUSTABLE 380131-01 PLATE SPRING 907272-06 WASHER FLAT 4.3 MM 906883-04 SCREW PAN HEAD S.T. 2.9 X 9.5MM 906805-03 SCREW FLAT HEAD S.T. 2.9 X 9.5MM 380129-01 FOOT PLASTIC 380018-05 CABLE KEYBOARD ASSY II HITEK |
| 313276-04 A3000 SHIPPING ASSY (CANADA) 25 MHZ | 363327-01 BOX PACKING CPU 320408-04 BAG FLAT 650 X 650 MM 318992-01 PACKING END CAP 318993-01 PACKING SPACER 318170-01 CARD READ THIS FIRST 316840-01 LABEL UPC 313278-04 MAIN ASSY (NTSC 110V) 25MHZ 903508-15 CORD POWER 327124-02 MOUSE ASSY 313323-02 KEYBOARD A3000 (U.S.) 363312-01 MANUAL A3000 QUICK CONNECT GUIDE 380426-01 FOAM NEOPOLEN SET (USE W/KEYBD) 251006-02 BAG FLAT 580MM X 350 MM (USE W/KEYBD) 324257-01 BAG DRYING AGENT 324252-07 TAPE ADHESIVE TRANSPARENT 50MM 315929-02 SOFTWARE SUB ASSY A3000 CANADA | 313323-02 KEYBOARD ASSY A3000 U.S. | 312458-01 HOUSING KEYBOARD TOP 312375-01 HOUSING KEYBOARD BOTTOM 312715-02 PCB ASSY KEYBOARD U.S. 380130-01 FOOT KEYBOARD ADJUSTABLE 380131-01 PLATE SPRING 907272-06 WASHER FLAT 4.3 MM 906883-04 SCREW PAN HEAD S.T. 2.9 X 9.5MM 906805-03 SCREW FLAT HEAD S.T. 2.9 X 9.5MM 380129-01 FOOT PLASTIC 380018-06 CABLE KEYBOARD ASSY II TOROID |
| | | 313323-03 KEYBOARD ASSY A3000 GERMANY | 312458-01 HOUSING KEYBOARD TOP 312375-01 HOUSING KEYBOARD BOTTOM 312715-04 PCB ASSY KEYBOARD ITALY 380130-01 FOOT KEYBOARD ADJUSTABLE 380131-01 PLATE SPRING 907272-06 WASHER FLAT 4.3 MM 906883-04 SCREW PAN HEAD S.T. 2.9 X 9.5MM 906805-03 SCREW FLAT HEAD S.T. 2.9 X 9.5MM 380129-01 FOOT PLASTIC 380018-05 CABLE KEYBOARD ASSY II HITEK |
| | | 313323-04 KEYBOARD ASSY A3000 ITALY | 312458-01 HOUSING KEYBOARD TOP 312375-01 HOUSING KEYBOARD BOTTOM 312715-04 PCB ASSY KEYBOARD ITALY 380130-01 FOOT KEYBOARD ADJUSTABLE 380131-01 PLATE SPRING 907272-06 WASHER FLAT 4.3 MM 906883-04 SCREW PAN HEAD S.T. 2.9 X 9.5MM 906805-03 SCREW FLAT HEAD S.T. 2.9 X 9.5MM 380129-01 FOOT PLASTIC 380018-05 CABLE KEYBOARD ASSY II HITEK |
| | | 313323-05 KEYBOARD ASSY A3000 FRANCE | 312458-01 HOUSING KEYBOARD TOP 312375-01 HOUSING KEYBOARD BOTTOM 312715-05 PCB ASSY KEYBOARD FRANCE 380130-01 FOOT KEYBOARD ADJUSTABLE 380131-01 PLATE SPRING 907272-06 WASHER FLAT 4.3 MM 906883-04 SCREW PAN HEAD S.T. 2.9 X 9.5MM 906805-03 SCREW FLAT HEAD S.T. 2.9 X 9.5MM 380129-01 FOOT PLASTIC 380018-05 CABLE KEYBOARD ASSY II HITEK |

Commodore International Spare Parts List
SHIPPING ASSEMBLIES (Continued)

| | | | |
|------------------|---|------------------|---|
| 313323-06 | KEYBOARD ASSY A3000 SPAIN | 533001-01 | KEYBOARD SHIPPING ASSY U.K. |
| 312458-01 | HOUSING KEYBOARD TOP | 313323-01 | KEYBOARD ASSY U.K. |
| 312375-01 | HOUSING KEYBOARD BOTTOM | 316828-01 | LABEL CARTON U.K. |
| 312715-06 | PCB ASSY KEYBOARD SPAIN | 251006-02 | BAG FLAT 580 X 350 MM |
| 380130-01 | FOOT KEYBOARD ADJUSTABLE | 380426-01 | FOAM SET NEOPOLEN |
| 380131-01 | PLATE SPRING | 380425-03 | CONTAINER SHIPPING |
| 907272-06 | WASHER FLAT 4.3 MM | 324252-07 | TAPE TRANSPARENT ADHESIVE 50MM |
| 906883-04 | SCREW PAN HEAD S.T. 2.9 X 9.5MM | 327124-02 | MOUSE ASSY |
| 906805-03 | SCREW FLAT HEAD S.T. 2.9 X 9.5MM | 363303-01 | MANUAL USER A3000 U.K. |
| 380129-01 | FOOT PLASTIC | 327273-02 | MANUAL BASIC ENGLISH |
| 380018-05 | CABLE KEYBOARD ASSY II HITEK | 317241-01 | DISK ASSY 3.5 WORKBENCH V1.4 U.K. |
| 313323-07 | KEYBOARD ASSY A3000 SWISS | 317234-01 | DISK ASSY 3.5 AMIGA EXTRAS V1.4 INTERNATIONAL |
| 312458-01 | HOUSING KEYBOARD TOP | 325249-01 | CARD WARRANTY U.K. |
| 312375-01 | HOUSING KEYBOARD BOTTOM | 363313-01 | MANUAL WORKBENCH 1.4 ENGLISH |
| 312715-07 | PCB ASSY KEYBOARD SWISS | 363312-01 | MANUAL A3000 QUICK CONNECT GUIDE |
| 380130-01 | FOOT KEYBOARD ADJUSTABLE | 903508-12 | CORD POWER BSI MEDIUM BEIGE U.K. AUS |
| 380131-01 | PLATE SPRING | 390543-01 | TOOL TUNNING |
| 907272-06 | WASHER FLAT 4.3 MM | 533001-02 | KEYBOARD SHIPPING ASSY U.S. (NOT USED) |
| 906883-04 | SCREW PAN HEAD S.T. 2.9 X 9.5MM | 313323-02 | KEYBOARD ASSY U.S. |
| 906805-03 | SCREW FLAT HEAD S.T. 2.9 X 9.5MM | 316827-01 | LABEL CARTON U.S.A. |
| 380129-01 | FOOT PLASTIC | 251006-02 | BAG FLAT 580 X 350 MM |
| 380018-05 | CABLE KEYBOARD ASSY II HITEK | 380426-01 | FOAM SET NEOPOLEN |
| 313323-08 | KEYBOARD ASSY A3000 DENMARK | 380425-03 | CONTAINER SHIPPING |
| 312458-01 | HOUSING KEYBOARD TOP | 324252-07 | TAPE TRANSPARENT ADHESIVE 50MM |
| 312375-01 | HOUSING KEYBOARD BOTTOM | 327124-02 | MOUSE ASSY |
| 312715-08 | PCB ASSY KEYBOARD DENMARK | 363303-01 | MANUAL USER A3000 U.K. |
| 380130-01 | FOOT KEYBOARD ADJUSTABLE | 327273-02 | MANUAL BASIC ENGLISH |
| 380131-01 | PLATE SPRING | 317954-01 | DISK ASSY 3.5 WORKBENCH V1.4 U.S. |
| 907272-06 | WASHER FLAT 4.3 MM | 317235-01 | DISK ASSY 3.5 AMIGA EXTRAS V1.4 U.S. |
| 906883-04 | SCREW PAN HEAD S.T. 2.9 X 9.5MM | 318896-01 | CARD SOFTWARE LICENSE AGREEMENT |
| 906805-03 | SCREW FLAT HEAD S.T. 2.9 X 9.5MM | 318903-01 | CARD WARRANTY U.S.A. |
| 380129-01 | FOOT PLASTIC | 312341-02 | CARD DISK EXCHANGE U.S.A. |
| 380018-05 | CABLE KEYBOARD ASSY II HITEK | 363313-01 | MANUAL WORKBENCH 1.4 ENGLISH |
| 313323-09 | KEYBOARD ASSY A3000 NORWAY | 314877-02 | BOOKLET SERVICE CENTER LIST U.S.A. |
| 312458-01 | HOUSING KEYBOARD TOP | 380720-01 | CARD REMINDER DISK & PRINTER CAUTIONS |
| 312375-01 | HOUSING KEYBOARD BOTTOM | 363312-01 | MANUAL A3000 QUICK CONNECT GUIDE |
| 312715-09 | PCB ASSY KEYBOARD NORWAY | 903508-15 | CORD POWER MEDIUM BEIGE CSA/U.S. |
| 380130-01 | FOOT KEYBOARD ADJUSTABLE | 390543-01 | TOOL TUNNING |
| 380131-01 | PLATE SPRING | 533001-03 | KEYBOARD SHIPPING ASSY GERMANY |
| 907272-06 | WASHER FLAT 4.3 MM | 313323-03 | KEYBOARD ASSY GERMAN |
| 906883-04 | SCREW PAN HEAD S.T. 2.9 X 9.5MM | 316831-01 | LABEL CARTON GERMAN |
| 906805-03 | SCREW FLAT HEAD S.T. 2.9 X 9.5MM | 251006-02 | BAG FLAT 580 X 350 MM |
| 380129-01 | FOOT PLASTIC | 380426-01 | FOAM SET NEOPOLEN |
| 380018-05 | CABLE KEYBOARD ASSY II HITEK | 380425-03 | CONTAINER SHIPPING |
| 313323-10 | KEYBOARD ASSY A3000 SWEDEN/FINLAND | 324252-07 | TAPE TRANSPARENT ADHESIVE 50MM |
| 312458-01 | HOUSING KEYBOARD TOP | 327124-02 | MOUSE ASSY |
| 312375-01 | HOUSING KEYBOARD BOTTOM | 363306-01 | MANUAL USER A3000 GERMAN |
| 312715-10 | PCB ASSY KEYBOARD SWEDEN/FINLAND | 380798-02 | MANUAL BASIC GERMAN |
| 380130-01 | FOOT KEYBOARD ADJUSTABLE | 317244-01 | DISK ASSY 3.5 WORKBENCH V1.4 GERMAN |
| 380131-01 | PLATE SPRING | 317236-01 | DISK ASSY 3.5 AMIGA EXTRAS V1.4 GERMAN |
| 907272-06 | WASHER FLAT 4.3 MM | 318708-02 | CARD PROGRAM LICENSE AGREEMENT GERMAN |
| 906883-04 | SCREW PAN HEAD S.T. 2.9 X 9.5MM | 320046-06 | CARD WARRANTY GERMAN |
| 906805-03 | SCREW FLAT HEAD S.T. 2.9 X 9.5MM | 363316-01 | MANUAL WORKBENCH 1.4 GERMAN |
| 380129-01 | FOOT PLASTIC | 363312-01 | MANUAL A3000 QUICK CONNECT GUIDE |
| 380018-05 | CABLE KEYBOARD ASSY II HITEK | 903508-11 | CORD POWER VDE MEDIUM BEIGE |
| 313323-11 | KEYBOARD ASSY A3000 ICELANDIC | 390543-01 | TOOL TUNNING |
| 312458-01 | HOUSING KEYBOARD TOP | 533001-04 | KEYBOARD SHIPPING ASSY ITALY |
| 312375-01 | HOUSING KEYBOARD BOTTOM | 313323-04 | KEYBOARD ASSY ITALY |
| 312715-11 | PCB ASSY KEYBOARD ICELANDIC | 316830-01 | LABEL CARTON ITALY |
| 380130-01 | FOOT KEYBOARD ADJUSTABLE | 251006-02 | BAG FLAT 580 X 350 MM |
| 380131-01 | PLATE SPRING | 380426-01 | FOAM SET NEOPOLEN |
| 907272-06 | WASHER FLAT 4.3 MM | 380425-03 | CONTAINER SHIPPING |
| 906883-04 | SCREW PAN HEAD S.T. 2.9 X 9.5MM | 324252-07 | TAPE TRANSPARENT ADHESIVE 50MM |
| 906805-03 | SCREW FLAT HEAD S.T. 2.9 X 9.5MM | 327124-02 | MOUSE ASSY |
| 380129-01 | FOOT PLASTIC | 363305-01 | MANUAL USER A3000 ITALIAN |
| 380018-05 | CABLE KEYBOARD ASSY II HITEK | 380798-04 | MANUAL BASIC ITALIAN |
| | | 317243-01 | DISK ASSY 3.5 WORKBENCH V1.4 ITALIAN |
| | | 317234-01 | DISK ASSY 3.5 AMIGA EXTRAS V1.4 INTERNATIONAL |
| | | 363315-01 | MANUAL WORKBENCH 1.4 ITALIAN |
| | | 363312-01 | MANUAL A3000 QUICK CONNECT GUIDE |
| | | 903508-11 | CORD POWER VDE MEDIUM BEIGE |
| | | 390543-01 | TOOL TUNNING |

Commodore International Spare Parts List
SHIPPING ASSEMBLIES (Continued)

| | | | |
|------------------|---|------------------|---|
| 533001-05 | KEYBOARD SHIPPING ASSY FRANCE | 533001-09 | KEYBOARD SHIPPING ASSY NORWAY |
| 313323-05 | KEYBOARD ASSY FRANCE | 313323-09 | KEYBOARD ASSY NORWAY |
| 316829-01 | LABEL CARTON FRANCE | 316838-01 | LABEL CARTON NORWAY |
| 251006-02 | BAG FLAT 580 X 350 MM | 251006-02 | BAG FLAT 580 X 350 MM |
| 380426-01 | FOAM SET NEOPOLEN | 380426-01 | FOAM SET NEOPOLEN |
| 380425-03 | CONTAINER SHIPPING | 380425-03 | CONTAINER SHIPPING |
| 324252-07 | TAPE TRANSPARENT ADHESIVE 50MM | 324252-07 | TAPE TRANSPARENT ADHESIVE 50MM |
| 327124-02 | MOUSE ASSY | 327124-02 | MOUSE ASSY |
| 363304-01 | MANUAL USER A3000 FRENCH | 363310-01 | MANUAL USER A3000 NORWEGIAN |
| 380798-03 | MANUAL BASIC FRENCH | 327273-02 | MANUAL BASIC ENGLISH |
| 317242-01 | DISK ASSY 3.5 WORKBENCH V1.4 FRENCH | 317247-01 | DISK ASSY 3.5 WORKBENCH V1.4 NORWEGIAN |
| 317234-01 | DISK ASSY 3.5 AMIGA EXTRAS V1.4 INTERNATIONAL | 317234-01 | DISK ASSY 3.5 AMIGA EXTRAS V1.4 INTERNATIONAL |
| 325254-01 | CARD WARRANTY FRENCH | 363313-01 | MANUAL WORKBENCH 1.4 ENGLISH |
| 363314-01 | MANUAL WORKBENCH 1.4 FRENCH | 363312-01 | MANUAL A3000 QUICK CONNECT GUIDE |
| 363312-01 | MANUAL A3000 QUICK CONNECT GUIDE | 903508-11 | CORD POWER VDE MEDIUM BEIGE |
| 903508-11 | CORD POWER VDE MEDIUM BEIGE | 390543-01 | TOOL TUNNING |
| 390543-01 | TOOL TUNNING | 533001-10 | KEYBOARD SHIPPING ASSY FINLAND |
| 533001-06 | KEYBOARD SHIPPING ASSY SPAIN | 313323-10 | KEYBOARD ASSY SWEDEN/FINLAND |
| 313323-06 | KEYBOARD ASSY SPAIN | 316837-01 | LABEL CARTON FINLAND |
| 316832-01 | LABEL CARTON SPAIN | 251006-02 | BAG FLAT 580 X 350 MM |
| 251006-02 | BAG FLAT 580 X 350 MM | 380426-01 | FOAM SET NEOPOLEN |
| 380426-01 | FOAM SET NEOPOLEN | 380425-03 | CONTAINER SHIPPING |
| 380425-03 | CONTAINER SHIPPING | 324252-07 | TAPE TRANSPARENT ADHESIVE 50MM |
| 324252-07 | TAPE TRANSPARENT ADHESIVE 50MM | 327124-02 | MOUSE ASSY |
| 327124-02 | MOUSE ASSY | 363303-01 | MANUAL USER A3000 U.K. |
| 363307-01 | MANUAL USER A3000 SPANISH | 327273-02 | MANUAL BASIC ENGLISH |
| 380798-06 | MANUAL BASIC SPANISH | 317240-01 | DISK ASSY 3.5 WORKBENCH V1.4 INTERNATIONAL |
| 317245-01 | DISK ASSY 3.5 WORKBENCH V1.4 SPANISH | 317234-01 | DISK ASSY 3.5 AMIGA EXTRAS V1.4 INTERNATIONAL |
| 317234-01 | DISK ASSY 3.5 AMIGA EXTRAS V1.4 INTERNATIONAL | 363313-01 | MANUAL WORKBENCH 1.4 ENGLISH |
| 363317-01 | MANUAL WORKBENCH 1.4 SPANISH | 363312-01 | MANUAL A3000 QUICK CONNECT GUIDE |
| 363312-01 | MANUAL A3000 QUICK CONNECT GUIDE | 903508-11 | CORD POWER VDE MEDIUM BEIGE |
| 903508-11 | CORD POWER VDE MEDIUM BEIGE | 390543-01 | TOOL TUNNING |
| 390543-01 | TOOL TUNNING | 533001-11 | KEYBOARD SHIPPING ASSY SWEDEN |
| 533001-07 | KEYBOARD SHIPPING ASSY NETHERLANDS | 313323-10 | KEYBOARD ASSY SWEDEN/FINLAND |
| 313323-07 | KEYBOARD ASSY DUTCH | 316839-01 | LABEL CARTON SWEDEN |
| 316836-01 | LABEL CARTON DUTCH | 251006-02 | BAG FLAT 580 X 350 MM |
| 251006-02 | BAG FLAT 580 X 350 MM | 380426-01 | FOAM SET NEOPOLEN |
| 380426-01 | FOAM SET NEOPOLEN | 380425-03 | CONTAINER SHIPPING |
| 380425-03 | CONTAINER SHIPPING | 324252-07 | TAPE TRANSPARENT ADHESIVE 50MM |
| 324252-07 | TAPE TRANSPARENT ADHESIVE 50MM | 327124-02 | MOUSE ASSY |
| 327124-02 | MOUSE ASSY | 363311-01 | MANUAL USER A3000 SWEDISH |
| 363309-01 | MANUAL USER A3000 DUTCH | 380798-05 | MANUAL BASIC SWEDISH |
| 380798-09 | MANUAL BASIC DUTCH | 317248-01 | DISK ASSY 3.5 WORKBENCH V1.4 SWEDISH |
| 317240-01 | DISK ASSY 3.5 WORKBENCH V1.4 INTERNATIONAL | 317234-01 | DISK ASSY 3.5 AMIGA EXTRAS V1.4 INTERNATIONAL |
| 317234-01 | DISK ASSY 3.5 AMIGA EXTRAS V1.4 INTERNATIONAL | 363313-01 | MANUAL WORKBENCH 1.4 ENGLISH |
| 363313-01 | MANUAL WORKBENCH 1.4 ENGLISH | 363312-01 | MANUAL A3000 QUICK CONNECT GUIDE |
| 363312-01 | MANUAL A3000 QUICK CONNECT GUIDE | 903508-11 | CORD POWER VDE MEDIUM BEIGE |
| 903508-11 | CORD POWER VDE MEDIUM BEIGE | 390543-01 | TOOL TUNNING |
| 390543-01 | TOOL TUNNING | 533001-12 | KEYBOARD SHIPPING ASSY ICELANDIC |
| 533001-08 | KEYBOARD SHIPPING ASSY DENMARK | 313323-01 | KEYBOARD ASSY U.K. |
| 313323-08 | KEYBOARD ASSY DENMARK | 313323-11 | KEYBOARD ASSY ICELANDIC |
| 316835-01 | LABEL CARTON DENMARK | 251006-02 | BAG FLAT 580 X 350 MM |
| 251006-02 | BAG FLAT 580 X 350 MM | 380426-01 | FOAM SET NEOPOLEN |
| 380426-01 | FOAM SET NEOPOLEN | 380425-03 | CONTAINER SHIPPING |
| 380425-03 | CONTAINER SHIPPING | 324252-07 | TAPE TRANSPARENT ADHESIVE 50MM |
| 324252-07 | TAPE TRANSPARENT ADHESIVE 50MM | 327124-02 | MOUSE ASSY |
| 327124-02 | MOUSE ASSY | 327273-02 | MANUAL BASIC ENGLISH |
| 363308-01 | MANUAL USER A3000 DANISH | 317240-01 | DISK ASSY 3.5 WORKBENCH V1.4 INTERNATIONAL |
| 327273-02 | MANUAL BASIC ENGLISH | 317234-01 | DISK ASSY 3.5 AMIGA EXTRAS V1.4 INTERNATIONAL |
| 317246-01 | DISK ASSY 3.5 WORKBENCH V1.4 DANISH | 363313-01 | MANUAL WORKBENCH 1.4 ENGLISH |
| 317234-01 | DISK ASSY 3.5 AMIGA EXTRAS V1.4 INTERNATIONAL | 363312-01 | MANUAL A3000 QUICK CONNECT GUIDE |
| 363313-01 | MANUAL WORKBENCH 1.4 ENGLISH | 903508-11 | CORD POWER VDE MEDIUM BEIGE |
| 363312-01 | MANUAL A3000 QUICK CONNECT GUIDE | 390543-01 | TOOL TUNNING |
| 903508-11 | CORD POWER VDE MEDIUM BEIGE | | |
| 390543-01 | TOOL TUNNING | | |

Commodore International Spare Parts List
SHIPPING ASSEMBLIES (Continued)

| | | | |
|------------------|---|------------------|---------------------------------------|
| 533001-13 | KEYBOARD SHIPPING ASSY BELGIUM | 315929-01 | SOFTWARE SUB ASSY A3000 (U.S.) |
| 313323-05 | KEYBOARD ASSY FRANCE | 317954-01 | DISKETTE ASSY WORKBENCH 1.4 (ENG) |
| 251006-02 | BAG FLAT 580 X 350 MM | 317235-01 | DISKETTE ASSY AMIGA EXTRAS 1.4 (ENG) |
| 380426-01 | FOAM SET NEOPOLEN | 318843-01 | DISKETTE HOLDER |
| 380425-03 | CONTAINER SHIPPING | 318611-01 | LABEL STOP |
| 324252-07 | TAPE TRANSPARENT ADHESIVE 50MM | 318270-01 | CARD WARRANTY (U.S.) |
| 327124-02 | MOUSE ASSY | 312341-02 | CARD DISK EXCHANGE (U.S.) |
| 363309-01 | MANUAL USER A3000 DUTCH | 363303-01 | MANUAL USER A3000 (ENG) |
| 380798-09 | MANUAL BASIC DUTCH | 327273-02 | MANUAL BASIC (ENG) |
| 317249-01 | DISK ASSY 3.5 WORKBENCH V1.4 BELGIUM | 363313-01 | MANUAL WORKBENCH 1.4 (ENG) |
| 317234-01 | DISK ASSY 3.5 AMIGA EXTRAS V1.4 INTERNATIONAL | 318896-01 | CARD SOFTWARE LICENSE AGREEMENT |
| 363314-01 | MANUAL WORKBENCH 1.4 FRENCH | 314877-04 | BOOKLET SERVICE CENTER LIST |
| 316833-12 | LABEL CARTON BELGIUM | 380720-01 | CARD REMINDER DISK/PRINTER CAUTIONS |
| 363312-01 | MANUAL A3000 QUICK CONNECT GUIDE | 318757-16 | SHRINK WRAP |
| 903508-11 | CORD POWER VDE MEDIUM BEIGE | 317201-01 | DISKETTE ASSY A3000 HD |
| 390543-01 | TOOL TUNNING | 390543-01 | TOOL TUNNING |
| 533001-14 | KEYBOARD SHIPPING ASSY CANADA (NOT USED) | 315929-02 | SOFTWARE SUB ASSY A3000 (CAN.) |
| 313323-02 | KEYBOARD ASSY U.S. | 317954-01 | DISKETTE ASSY WORKBENCH 1.4 (ENG) |
| 251006-02 | BAG FLAT 580 X 350 MM | 317235-01 | DISKETTE ASSY AMIGA EXTRAS 1.4 (ENG) |
| 380426-01 | FOAM SET NEOPOLEN | 318843-01 | DISKETTE HOLDER |
| 380425-03 | CONTAINER SHIPPING | 318611-01 | LABEL STOP |
| 324252-07 | TAPE TRANSPARENT ADHESIVE 50MM | 318882-01 | CARD WARRANTY (CAN.) |
| 327124-02 | MOUSE ASSY | 318556-02 | CARD DISK EXCHANGE (CAN.) |
| 363303-01 | MANUAL USER A3000 U.K. | 363303-01 | MANUAL USER A3000 (ENG) |
| 327273-02 | MANUAL BASIC ENGLISH | 327273-02 | MANUAL BASIC (ENG) |
| 317241-01 | DISK ASSY 3.5 WORKBENCH V1.4 U.K. | 363313-01 | MANUAL WORKBENCH 1.4 (ENG) |
| 317235-01 | DISK ASSY 3.5 AMIGA EXTRAS V1.4 U.S. | 318896-01 | CARD SOFTWARE LICENSE AGREEMENT |
| 318896-01 | CARD SOFTWARE LICENSE AGREEMENT | 380720-01 | CARD REMINDER DISK/PRINTER CAUTIONS |
| 363313-01 | MANUAL WORKBENCH 1.4 ENGLISH | 318757-16 | SHRINK WRAP |
| 380720-01 | CARD REMINDER DISK & PRINTER CAUTIONS | 317201-01 | DISKETTE ASSY A3000 HD |
| 316834-01 | LABEL CARTON CANADA | 390543-01 | TOOL TUNNING |
| 318556-02 | CARD DISK EXCHANGE CANADA | | |
| 318882-01 | CARD WARRANTY CANADA | | |
| 363312-01 | MANUAL A3000 QUICK CONNECT GUIDE | | |
| 903508-15 | CORD POWER MEDIUM BEIGE CSA/U.S. | | |
| 390543-01 | TOOL TUNNING | | |
| 533001-15 | KEYBOARD SHIPPING ASSY AUSTRALIA | | |
| 313323-01 | KEYBOARD ASSY U.K. | | |
| 251006-02 | BAG FLAT 580 X 350 MM | | |
| 380426-01 | FOAM SET NEOPOLEN | | |
| 380425-03 | CONTAINER SHIPPING | | |
| 324252-07 | TAPE TRANSPARENT ADHESIVE 50MM | | |
| 327124-02 | MOUSE ASSY | | |
| 363303-01 | MANUAL USER A3000 U.K. | | |
| 327273-02 | MANUAL BASIC ENGLISH | | |
| 317241-01 | DISK ASSY 3.5 WORKBENCH V1.4 U.K. | | |
| 317234-01 | DISK ASSY 3.5 AMIGA EXTRAS V1.4 INTERNATIONAL | | |
| 363313-01 | MANUAL WORKBENCH 1.4 ENGLISH | | |
| 318884-01 | CARD WARRANTY AUSTRALIA | | |
| 363312-01 | MANUAL A3000 QUICK CONNECT GUIDE | | |
| 903508-12 | CORD POWER BSI MEDIUM BEIGE U.K. AUS | | |
| 390543-01 | TOOL TUNNING | | |

Commodore International Spare Parts List MAJOR ASSEMBLIES

Commodore part numbers are provided for reference only and do not indicate the availability of spare parts from Commodore. Industry standard parts (Resistors, Capacitors, Connectors) should be secured locally. Part number information may vary according to country, some parts may not be available in all countries.

| | | | |
|------------------|--|---------------------------------------|---|
| MAIN ASSY | | MOUNTING BRACKET ASSY - A3000 | |
| 313278-01 | MAIN ASSY PAL 220V 16MHZ | 313285-01 | BRACKET ASSY MOUNTING 240 VOLT |
| 313278-02 | MAIN ASSY NTSC 110V 16MHZ | 313285-02 | BRACKET ASSY MOUNTING 120 VOLT |
| 313278-03 | MAIN ASSY PAL 220V 16MHZ | 313292-01 | BRACKET DRIVE & POWER SUPPLY MOUNTING |
| 313278-04 | MAIN ASSY NTSC 110V 25MHZ | 906800-05 | SCREW MACH M3 X 0.5 X 6.0 LG |
| 313281-01 | BASE ASSY PAL 16 MHZ | 390500-01 | POWER SUPPLY A3000 240 VOLT |
| 313281-02 | BASE ASSY NTSC 16 MHZ | 390500-02 | POWER SUPPLY A3000 120 VOLT |
| 313281-03 | BASE ASSY PAL 25 MHZ | LED HOLDER ASSEMBLY | |
| 313281-04 | BASE ASSY NTSC 25 MHZ | 313303-01 | LED HOLDER ASSY |
| 313319-01 | DRIVE ASSY HARD (ADD CABLE CONNECTIONS) | 313556-01 | LED 2.0MM X 10.0MM GREEN LED |
| 313318-01 | DRIVE ASSY FLOPPY (ADD CABLE CONNECTIONS) | 313568-01 | LED 2.0MM X 10.0MM YELLOW LED |
| 313284-01 | BRACKET MOUNTING 3.5 DISK DRIVE | 313316-01 | LED PCB |
| 313250-01 | CARD EXPANSION PCB ASSY | 903351-05 | CONNECTOR HOUSING 5 PINS |
| 313299-01 | SUPPORT CONNECTOR BOARD | 903353-01 | CONNECTOR PINS |
| 318236-01 | INSULATION SHEET BACK PLANE | 903756-02 | LEAD WIRE AWG 24 RED L = 120.0MM |
| 313298-01 | ROD CONNECTING | 903756-10 | LEAD WIRE AWG 24 BLACK L = 120.0MM |
| 313297-01 | BUTTON POWER | COVER ASSY- A3000 | |
| 313301-01 | COVER ASSY | 313301-01 | COVER ASSY |
| 325542-02 | SCREW MACH. W/EXT. TOOTH 4 X 0.7 X 6.0 LG | 313279-01 | COVER TOP |
| BASE ASSY | | 313280-01 | BEZEL FRONT |
| 313281-01 | BASE ASSY PAL 16 MHZ | 906884-03 | SCREW SELF TAPPING M4 X 10.0 LG |
| 313281-02 | BASE ASSY NTSC 16MHZ | 313296-01 | COVER FLOPPY DRIVE HOLE |
| 313281-03 | BASE ASSY PAL 25 MHZ | 310317-03 | LENS FLOPPY LED |
| 313281-04 | BASE ASSY NTSC 25 MHZ | 3.5 HARD DISK DRIVE CABLE ASSY | |
| 313283-01 | MAIN CHASSIS BASE | 311829-01 | CABLE ASSY 3.5 HARD DISK DRIVE |
| 313293-01 | BRACKET OPTION CARD | 311829-02 | CABLE ASSY 3.5 HARD DISK DRIVE |
| 251118-01 | GUIDE PCB | 903468-07 | CONNECTOR SOCKET 50 POS |
| 906803-05 | SCREW FLAT HEAD M3 X 0.5 X 4.0 LG | 903134-11 | CABLE FLAT 50 POS X 575.0 ± 5.0 MM LG |
| 325542-02 | SCREW MACH W/EXT TOOTH M4 X 0.7 X 6.0 LG | DRIVE CABLE ASSY II A3000 | |
| 906800-05 | SCREW MACH M3 X 0.5 X 6.0 LG | 380742-01 | CABLE ASSY DRIVE II AMIGA/MATSUSHITA JU363-282/CHINON F354 |
| 390251-02 | STANDOFF D CONN | 380742-02 | CABLE ASSY DRIVE II AMIGA/MATSUSHITA JU253-02T/CHINON FB354 |
| 380128-01 | FOOT | 903135-10 | CABLE FLAT 34 POS L = 570MM |
| 313294-01 | BRACKET MOUSE & KEYBOARD PCB | 903468-05 | CONN DUAL ROW 34P |
| 313303-01 | LED HOLDER ASSY | 380328-01 | PLUG KEYING |
| 313310-01 | PCB ASSY PAL 16 MHZ | HARD DRIVE SUB ASSY | |
| 313310-02 | PCB ASSY NTSC 16 MHZ | 313319-01 | DRIVE HARD ASSY (SUBASSEMBLY) |
| 313310-03 | PCB ASSY PAL 25 MHZ | 313440-01 | DRIVE ASSY HARD DISK 40 MB SCSI (QUANTUM PRODRIVE 40S) |
| 313310-04 | PCB ASSY NTSC 25 MHZ | 906610-01 | SCREW MACH #6 - 32 X 1/4 |
| 318233-01 | INSULATION SHEET | 313314-01 | BRACKET MOUNTING 3.5 HDD |
| 390251-04 | STAND OFFS HEX M/F 5 MM | FLOPPY DRIVE SUB ASSY | |
| 316854-01 | LABEL FCC ID | 313318-01 | DRIVE ASSY, FLOPPY (SUBASSEMBLY) |
| 316791-01 | LABEL BACK PANEL | 313315-01 | DRIVE 3.5 FLOPPY DISK |
| 311829-02 | CABLE SCSI DRIVE | 313284-01 | BRACKET MOUNTING 3.5 DISK DRIVE |
| 380742-03 | CABLE FLOPPY DRIVE | 325541-03 | SCREW MACH W/EXT TOOTH M3 X 0.5 X 8.0 LG |
| 380120-01 | CARD PANEL EXTENSION | | |
| 380739-01 | CARD PANEL EXPANSION | | |
| 313277-01 | CARD PANEL EXTENSION - VIDEO ADAPTER | | |
| 390329-01 | SCREW MACH W/EXT TOOTH M3.5 X 0.6 X 5.0 LG | | |
| 313285-01 | BRACKET ASSY MOUNTING 240 V | | |
| 313285-02 | BRACKET ASSY MOUNTING 120 V | | |
| 390662- | STANDOFF HEX M/F | | |

Commodore International Spare Parts List PCB Components PCB Assembly #313310

Commodore part numbers are provided for reference only and do not indicate the availability of spare parts from Commodore. Industry standard parts (Resistors, Capacitors, Connectors) should be secured locally. Part number information may vary according to country, some parts may not be available in all countries.

| IC COMPONENTS | | RESISTOR PACKS (Continued) | |
|--|--|--|---|
| 901882-01 1488 901883-01 1489 318099-01 414256 100 NS 901522-30 7407 390420-01 74ALS163 390110-01 74F04 390203-01 74F08 390108-01 74F373 390089-01 74F245 390077-01 74F32 390281-01 74F646 390081-01 74F74 310001-01 74HC14 318828-01 74HCT244 901521-03 74LS08 901521-11 74LS157 901521-63 74LS174 390198-01 74F86 901521-01 74LS00 901521-06 74LS74A 318069-03 8372 FAT AGNUS 2 MEG 318029-02 8520 390538-01 AMBER 390433-01 8373 ECS DENISE 390537-01 DPMC 390539-01 FAT BUSTER 390540-01 FAT GARY 4141F008A 390530-01 MSM 514221RS-6 390086-01 LF347 390399-03 MC68030 16 MHZ QFP 390277-03 MC68881 16 MHZ PLCC 390339-04 MC68030 25 MHZ QFP 390434-02 MC68882 25 MHZ PLCC 390531-01 NE564 252127-01 PAULA 390532-01 UPD 42101C-2 390206-01 WD33C93 328156-02 PST518 390541-01 RAM CONTROLLER 390525-01 RP5C01 390630-01 ROM V1.4 32 BIT HIGH WORD 390629-01 ROM V1.4 32 BIT LOW WORD 390555-01 DELAY LINE 25 NS 390526-01 PAL PROG 16L8D 390527-01 PAL PROG 16L8D 390528-01 PAL PROG 16R4A 390529-01 PAL PROG 16L8D | U304 U305 U850-U881,U274(U263-U266,U271-U274,U858-U881) NOT INSERTED U713,U801 U476 U204,U711 U303,U710 U251 U702,U708,U709,U715,U716,U257,U258,U891-U894 U712 U253-U256,U703-U707 U106 U477 U451-U452 U355 U401 U195,U354 U252 U353 U201,U351,U480 U205 U300,U350 U478 U450 U802 U700 U110 U470-U472 U402 U100 U101 U100 U101 U481 U400 U473-U475,U479 U800 U112 U890 U190 U181 U180 U102 U202 U203 U701 U714 | 902410-10 RPK 1K OHM 9 X 10 902441-31 RPK 4.7K OHM 5 X 6 902422-22 1K OHM 7 X 8 902441-17 470 OHM 5 X 6 380388-04 220/330 10 PIN 380388-01 220/330 6 PIN RESISTORS 5% @ ¼ WATT, CARBON FILM, UNLESS OTHERWISE SPECIFIED 901550-118 1 OHM 901550-17 1.2K OHM 901550-64 10 OHM 901550-20 10K OHM 901550-137 91 OHM 901550-01 1K OHM 901550-23 2.7K OHM 901550-112 200 OHM 901550-02 3.3K OHM 901550-105 33 OHM 901550-108 360 OHM 901550-57 390 OHM 901550-19 4.7K OHM 901550-56 47 OHM 901550-58 470 OHM 901550-82 470K OHM 901550-131 56 OHM 901550-94 68 OHM 901550-114 9.1K OHM 901550-63 22 OHM 901550-07 100K OHM 901600-36 1 OHM ½W 5% CARBON 901600-15 47 OHM ½W 5% CARBON UNSTUFFED RESISTOR | RP100-RP110,RP351,RP703 RP453-RP455 RP609,RP610,RP180 RP701 RP802,RP804 RP803 R400,R478,R479 R401,R402 R403,R404,R484 R191,R305,R306,R405, R406,R408,R431,R432, R441,R442,R451,R452, R454 R489 R302,R433,R443,R482, R483,R487,R803,R805 R407 R301 R110,R112 R472,R473,R475-R477, R896 R430,R440 R434,R444 R203 R202,R204,R895 R190,R192,R699 R435,R445 R300 R307 R408 R100-R101,R106,R109, R450,R809 R193 R420 R353 R409 |
| OSCILLATORS | | CAPACITORS | |
| 252344-01 28.375 MHZ (PAL) 325566-14 28.6363 MHZ (NTSC) 325566-24 32 MHZ 325566-27 50 MHZ OSC | U111 U111 U104 U104 U103 UNSTUFFED | 900462-20 20 PF AXIAL 900462-29 47 PF AXIAL 900462-31 56 PF AXIAL 900462-37 100 PF NPO AXIAL 900463-08 220 PF AXIAL 900463-23 3900 PF AXIAL 900463-26 6800 PF AXIAL 900463-28 .01 UF AXIAL 900463-36 .047 UF AXIAL 900462-27 39 PF AXIAL 390082-01 .1 UF AXIAL MLC 390082-05 .22 UF AXIAL MLC 390082-04 .33 UF AXIAL MLC 900402-13 1.0 UF RADIAL TANT 390101-05 4.7 UF RADIAL ELECTROLYTIC | C192 C458 C193 C420-C422,C459,C491 C496,C498 C108,C109 C432,C442 C431,C441 C103,C104,C161,C170, C172,C174,C176,C177, C402 C411-C414 C497 C102,C106,C111,C191, C195,C201-C205,C251- C258,C300,C305,C350- C355,C362,C400,C401, C409,C410,C415,C434, C444,C451-C452,C470- C482,C484-C486,C489, C490,C494,C495 C100,C101,C110,C180- C183,C403,C405,C406, C450,C455-C457,C700- C716 C259-C274,C800,C801, C850-C873,C890-C894 C487,C488 C190,C404 |
| RESISTOR PACKS | | | |
| 326149-01 22 OHM 4 X 8 326149-04 47 OHM 4 X 8 326149-06 63 OHM 4 X 8 902410-11 470 OHM 9 X 10 902441-22 1K OHM 5 X 6 902410-08 4.7K OHM 9 X 10 390227-03 22 OHM 5 X 10 902410-06 3.3K OHM 5 X 10 390227-06 47 OHM 5 X 10 | RP700,RP890,RP891 RP252-RP254,RP451, RP452 RP401 RP256 RP600,RP601,RP702 RP400 RP892,RP893 RP350,RP800,RP801 RP201,RP251,RP255 | | |

Commodore International Spare Parts List
PCB Components (Continued)
PCB Assembly #313310

| CAPACITORS (Continued) | | | MISCELLANEOUS (Continued) | | |
|------------------------|-------------------------------|---|---------------------------|-------------------------------|--|
| 900402-01 | 10 UF RADIAL TANT | C483 | 390280-01 | FUSE 3A | F300,F350,F351,F400,F450 |
| 390101-04 | 22 UF RADIAL ELECTROLYTIC | C105,C107,C113,C317,C318,C433,C443 | 903025-01 | FERRITE BEAD | FB110,FB111,FB400,FB401,FB420-FB422,FB480-FB487 |
| 390101-01 | 47 UF RADIAL ELECTROLYTIC | C112,C162-C169,C171,C173,C175,C407,C408,C899 | 903326-03 | HEADER SIL .100 | J101,J102,J104,J151,J152,J180,J200,J350-J352,J481-J483,J800,J851,J853 |
| 390101-02 | 100 UF RADIAL ELECTROLYTIC | C178 | 903326-05 | HEADER SIL .100 1 X 5 | J852 |
| 390101-03 | 470 UF RADIAL ELECTROLYTIC | C160,C416,C423,C454,C460,C492,C493 | 903326-04 | HEADER SIL .100 1 X 4 | J100,J103 |
| | UNSTUFFED RESERVED CAPACITORS | C307,C308,C430,C440 | 390229-01 | IC VIDEO HYBRID | HY450,HY480 |
| CONNECTORS | | | 902410-11 | RESISTOR PACK, 470 OHM 9 X 10 | RP256 |
| 252166-03 | KEYBOARD CONNECTORS | CN420 | 902442-06 | RESISTOR PACK, 68 OHM 4 X 8 | RP401 |
| 390557-01 | 200 PIN RECEPTACLE | CN606 | 904150-06 | SOCKET 40 PIN DIP | U180,U181,U300,U350,U800 |
| 903345-17 | 34 PIN DIL | CN351 | 251313-01 | SOCKET 48 PIN DIP | U400,U450 |
| 903345-25 | 50 PIN | CN802 | 390185-01 | SOCKET 84 PIN PLCC | U890,U110,U205,U700,U802 |
| 903374-05 | 5 PIN SIL RA | CN302 | 390185-02 | SOCKET 68 PIN PLCC | U478 |
| 903446-06 | CONN 100 | CN600 | 904150-01 | SOCKET 14 PIN DIP .300 | U103 |
| 252122-01 | RCA JACK WHITE | CN402 | 904150-08 | SOCKET 20 PIN DIP .300 | U202,U203,U267-U274,U701,U714,U850-U881 |
| 390334-01 | DB15 | CN480 | 390060-01 | SOCKET 24 PIN DIP .300 | U473,U474,U475,U479 |
| 390242-03 | D-SUB 23P MALE PCB | CN450 | 904150-06 | SOCKET 40 PIN DIP | U180,U181,U300,U350,U800 |
| 390242-05 | D SUB 25P MALE PCB | CN300 | 904150-02 | SOCKET 16 PIN DIP .300 | U470,U471,U472 |
| 390242-01 | D SUB 9P MALE PCB | CN400,CN401 | 390043-01 | SHUNT PACK DIP | J100-J104,J151,J152,J180,J181,J200,J350-J352,J481-J483,J800,J801,J851-J853 |
| 903446-05 | 85P EDGE DIL86 | CN451 | 251029-07 | CAP VAR 3-11 PF | VC470 |
| 390241-05 | DUAL DB25 FEMALE DP25S | CN350,CN801 | 251029-06 | CAP VAR 22-47 PF | VC190 |
| 390625-01 | POW15 | CN160 | 390546-01 | RES VAR 1K 15 TURN | VR470 |
| 252122-02 | RCA JACK RED | CN403 | 900560-01 | CRYSTAL 32768HZ | Y190 |
| 327033-04 | D SUB 23 PIN FEMALE PCB | CN352 | 390192-01 | TRANSISTOR 2N3904 | Q300 |
| MISCELLANEOUS | | | 902707-01 | TRANSISTOR 2N3906 | Q400 |
| 380393-01 | BATTERY NICAD 3.6V 60 MAH | BT190 | 390252-01 | TRANSISTOR MPF102 | Q430,Q440 |
| 390536-01 | SWITCH, S.P.S.T. TOGGLE RA | SW480 | | | |
| 900750-01 | DIODE 1N4001 | D192,D193 | | | |
| 900850-01 | DIODE 1N4148 | D190,D191,D300,D800 | | | |
| 251842-02 | EMI FILTERS 3 PIN | EM1300-EM1309,EM1350-EM1364,EM1430-EM1436,EM1440-EM1442,EM1444-EM1446,EM1450,EM1451,EM1453-EM1456,EM1458,EM1459,EM1490-EM1494 | | | |

Commodore International Spare Parts List
A3000 Daughter Board
PCB Assembly #313250-01

| IC COMPONENTS | | | CAPACITORS | | |
|---------------------|-------------------------|-------------|------------|---------------------|-------------------------|
| 380227-01 | 74HCT32 | U600 | 390082-01 | CER AXL .1 UF | C606 |
| RESISTOR PACKS | | | 390082-05 | CER AXL .22 UF | C752-C754,C849 |
| 902441-22 | SIP 1K 5 RES 6 PIN | RP611 | 900014-02 | CER RAD 1000 PF | C756-C799 |
| 902410-10 | SIP 1K 9 RES 10 PIN | RP752-RP756 | 900101-47 | ELEC AXL 220 UF 16V | C600-C603 |
| 380388-01 | SIP 220/330 4 RES 6 PIN | RP608 | 390101-04 | ELEC RAD 22 UF 16V | C751 |
| 380388-04 | 220/330 8 RES 10 PIN | RP602-RP607 | 900462-29 | CER AXL 47 PF 50V | C458 |
| 902410-08 | SIP 4.7K 9 RES 10 PIN | RP751 | CONNECTORS | | |
| RESISTORS, 1/4 WATT | | | 903446-06 | CARD EDGE 100 PIN | CN600-CN603 |
| 901550-58 | 470 OHM | R601 | 903446-04 | CARD EDGE 36 PIN | CN451,CN452,CN754,CN755 |
| 901550-01 | 1K OHM | R600 | 903446-02 | CARD EDGE 62 PIN | CN751,CN752 |

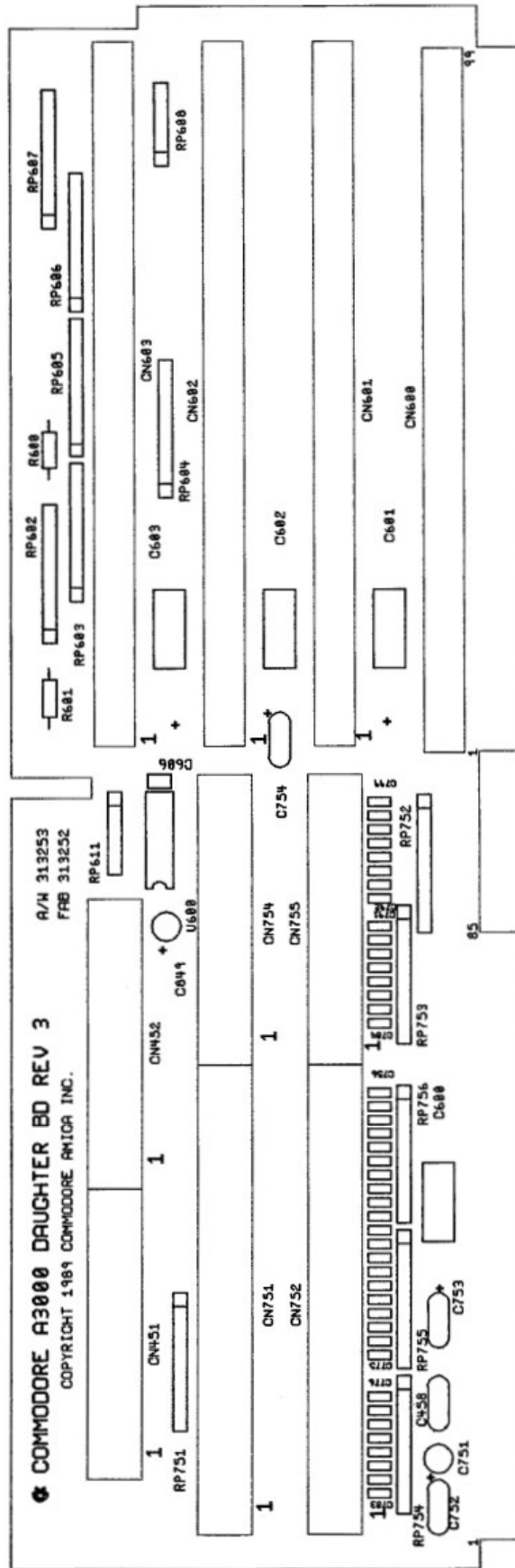

A3000 DAUGHTER BOARD, REV. 3

JUMPER SETTINGS

| JUMPER | PINS | 313311 | 313311 | 313311 | 313311 | FUNCTION |
|--------|------|--------|--------|--------|--------|---------------------------------|
| J100 | 4 | -01 | -02 | -03 | -04 | Quadrature Clock Phasing |
| J101 | 3 | 2-3 | 2-3 | 2-3 | 2-3 | FPU Clock Source |
| J102 | 3 | 2-3 | 2-3 | 2-3 | 2-3 | System Clock Source |
| J103 | 4 | 3-4 | 3-4 | 3-4 | 3-4 | FPU CS/BERR |
| J104 | 3 | 1-2 | 1-2 | 1-2 | 1-2 | CPU Clock Source |
| J200 | 3 | 1-2 | 2-3 | 1-2 | 2-3 | NTSC/PAL Select |
| J151 | 3 | 2-3 | 2-3 | 1-2 | 1-2 | Rom Timing |
| J152 | 3 | 2-3 | 2-3 | 1-2 | 1-2 | Rom Timing |
| J180 | 3 | 2-3 | 2-3 | 2-3 | 2-3 | A2000 ROM Compatibility Jumpers |
| J181 | 3 | 2-3 | 2-3 | 2-3 | 2-3 | A2000 ROM Compatibility Jumpers |
| J350 | 3 | 1-2 | 1-2 | 1-2 | 1-2 | Tick Clock Source |
| J351 | 3 | 2-3 | 2-3 | 2-3 | 2-3 | Disable DF1: (1-2 to enable) |
| J352 | 3 | 2-3 | 2-3 | 2-3 | 2-3 | Light Pen Source |
| J481 | 3 | 2-3 | 2-3 | 2-3 | 2-3 | VDE Scan Double Only Jumper |
| J482 | 3 | 1-2 | 1-2 | 1-2 | 1-2 | VDE PLL Loop Adjust |
| J483 | 3 | --- | --- | --- | --- | VDE Factory Test Points |
| J800 | 3 | 1-2 | 1-2 | 1-2 | 1-2 | WD33C93 Speed |
| J851 | 3 | 1-2 | 1-2 | 2-3 | 2-3 | RAM Controller Speed Jumper |
| J852 | 5 | 4-5 | 4-5 | 4-5 | 4-5 | -012A Ramsey only (See Notes) |
| J853 | 3 | 2-3 | 2-3 | 2-3 | 2-3 | -012A Ramsey only (See Notes) |

Notes:

J150, J151: Rom Timing

The rom timing circuit provides four different speed settings to match the output enable, and access timing of the system roms.

To set the jumpers, determine the output enable time, and access times for the roms you wish to use. The rom must have lower values than for the setting you select.

System standard roms have $T_{oe} = 110$ ns, and $T_{acc} = 250$ ns.

| CLK | J151 | J150 | T_{oe} (min) | T_{acc} (min) |
|--------|------|------|----------------|-----------------|
| 16 Mhz | 2-3 | 2-3 | 157 ns | 250 ns |
| 16 Mhz | 2-3 | 1-2 | 220 ns | 312 ns |
| 16 Mhz | 1-2 | 2-3 | 282 ns | 375 ns |
| 16 Mhz | 1-2 | 1-2 | 345 ns | 437 ns |
| 25 Mhz | 2-3 | 2-3 | 90 ns | 160 ns |
| 25 Mhz | 2-3 | 1-2 | 130 ns | 200 ns |
| 25 Mhz | 1-2 | 2-3 | 170 ns | 240 ns |
| 25 Mhz | 1-2 | 1-2 | 210 ns | 280 ns |

J180, J181: Rom Compatibility Jumpers

| | J180 | J181 |
|------------------|------|------|
| A2000/A500 ROMS: | 1-2 | 1-2 |
| A3000 ROMS: | 2-3 | 2-3 |

J851-J853: Ram Controller Compatibility Settings

| | J852 | J853 |
|------------------------------|------|------|
| -012A Ramsey w/ 256Kx4 rams | 4-5 | 2-3 |
| Later Ramseys w/ 256Kx4 rams | 2-3 | 1-2 |
| Later Ramseys w/ 1Mx4 rams | 1-2 | 1-2 |

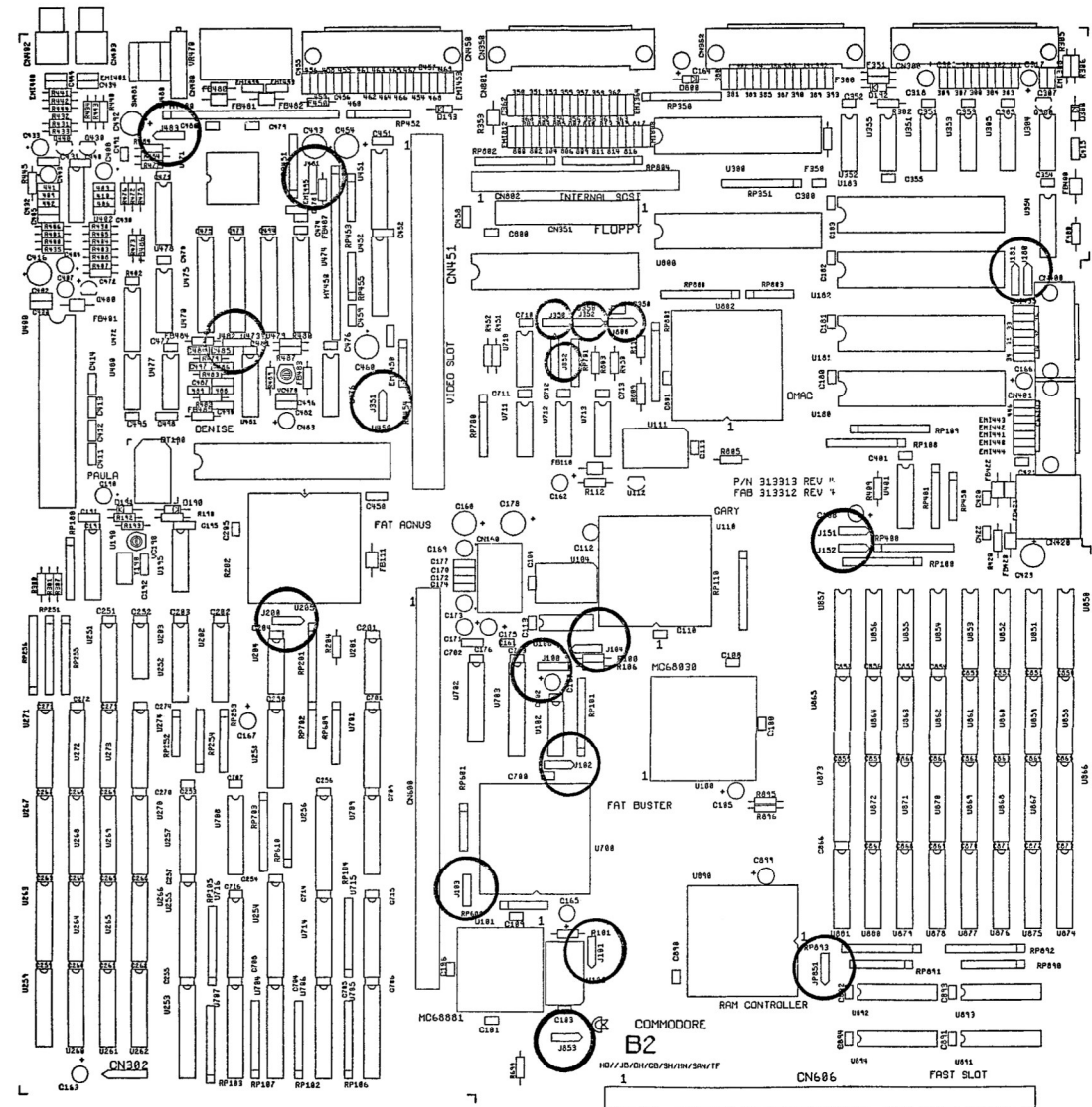

PCB BOARD LAYOUT #313311, REV. A

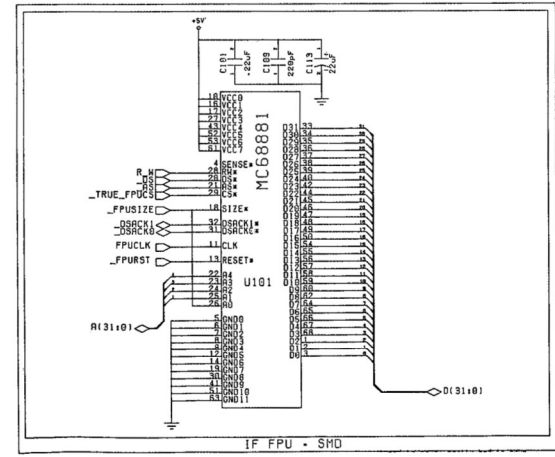
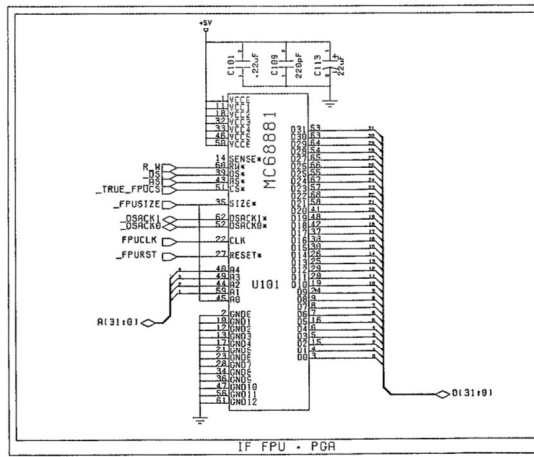
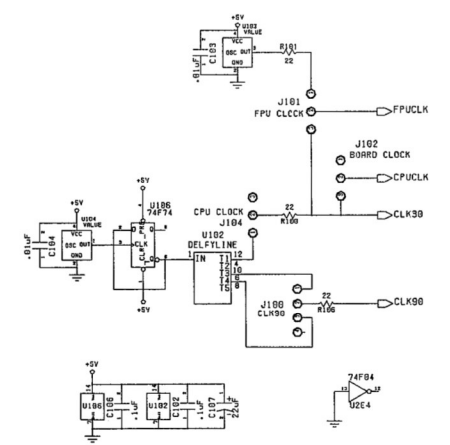
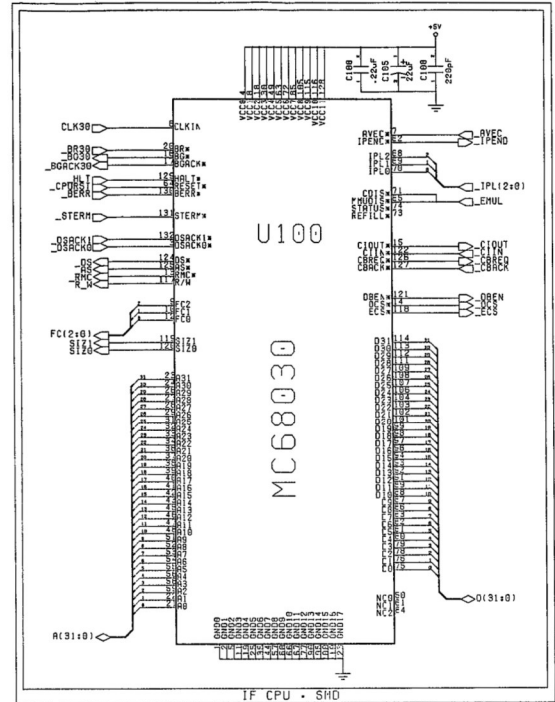
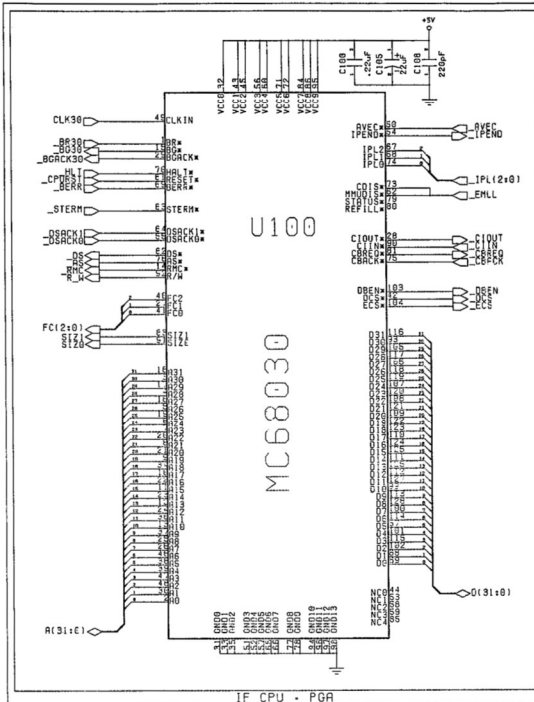
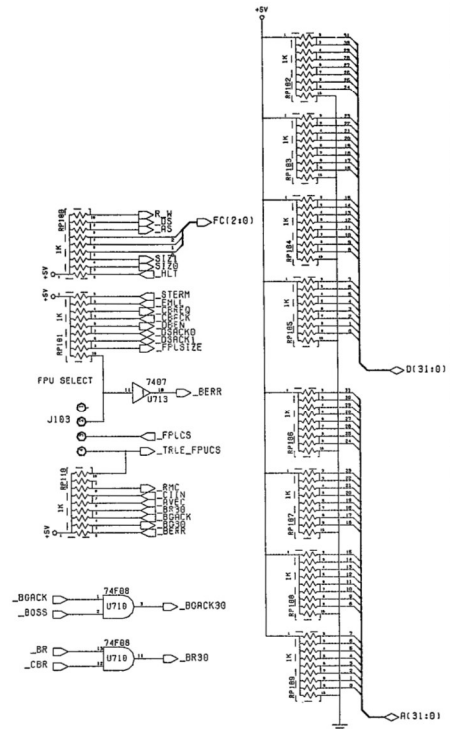

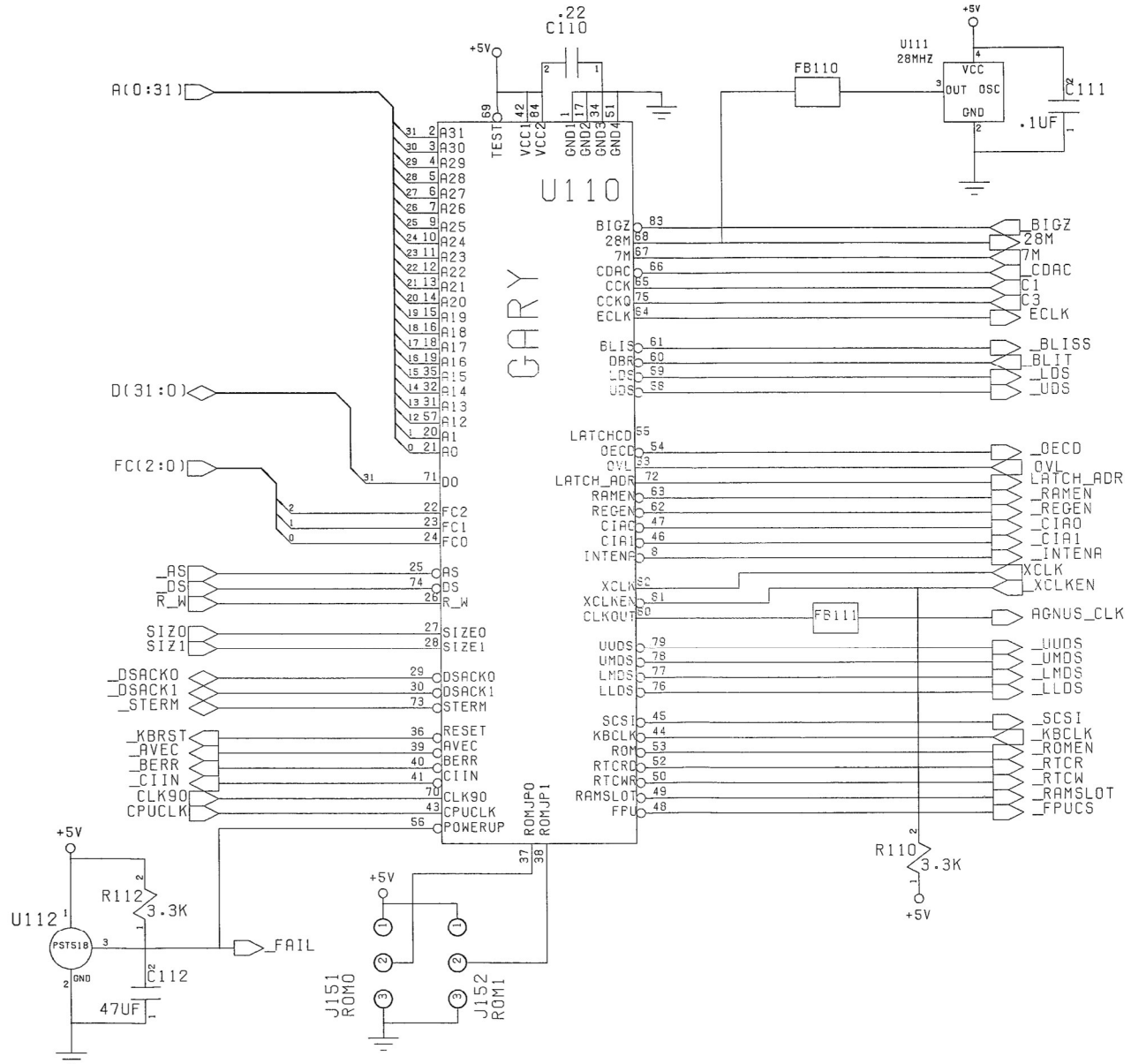

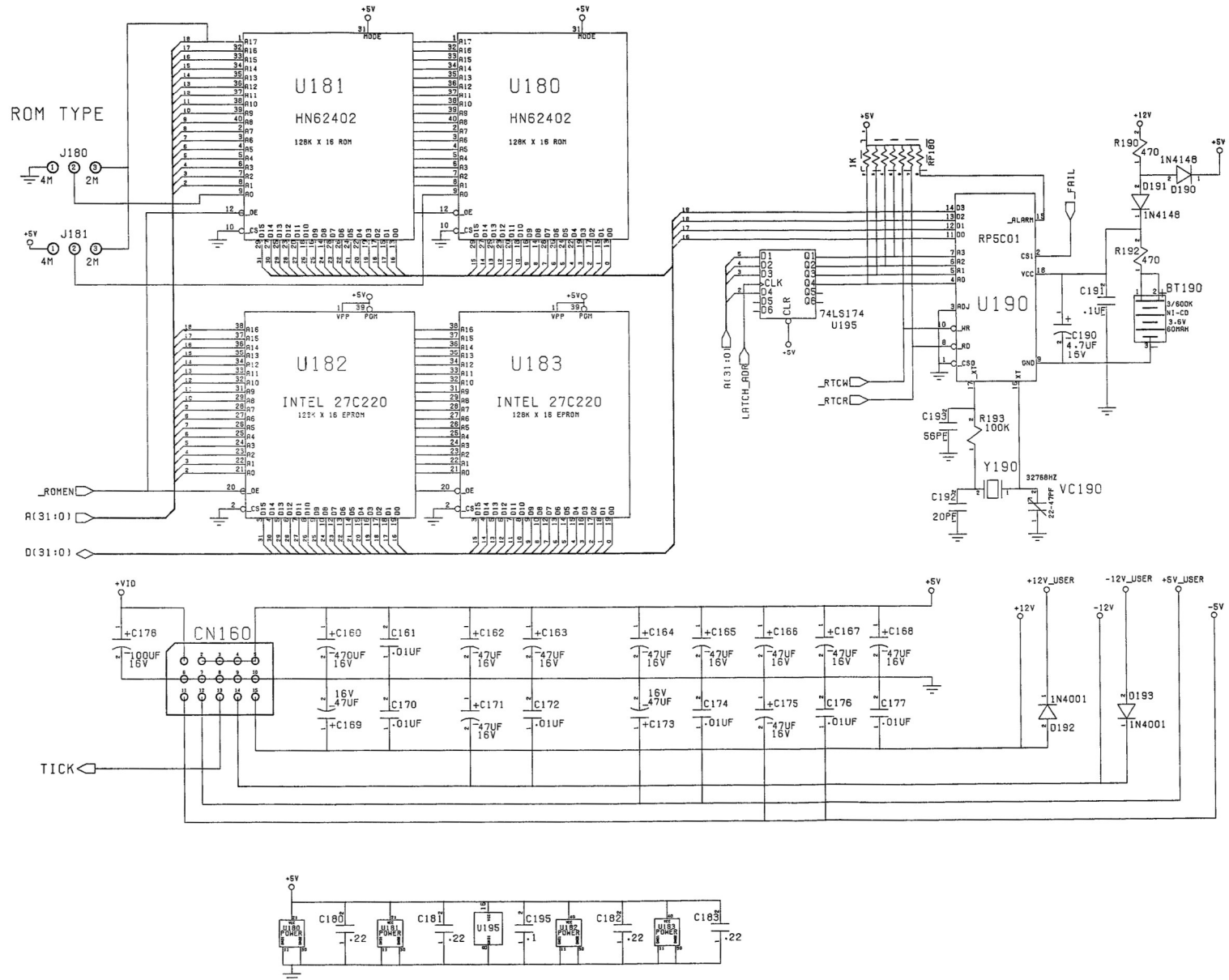

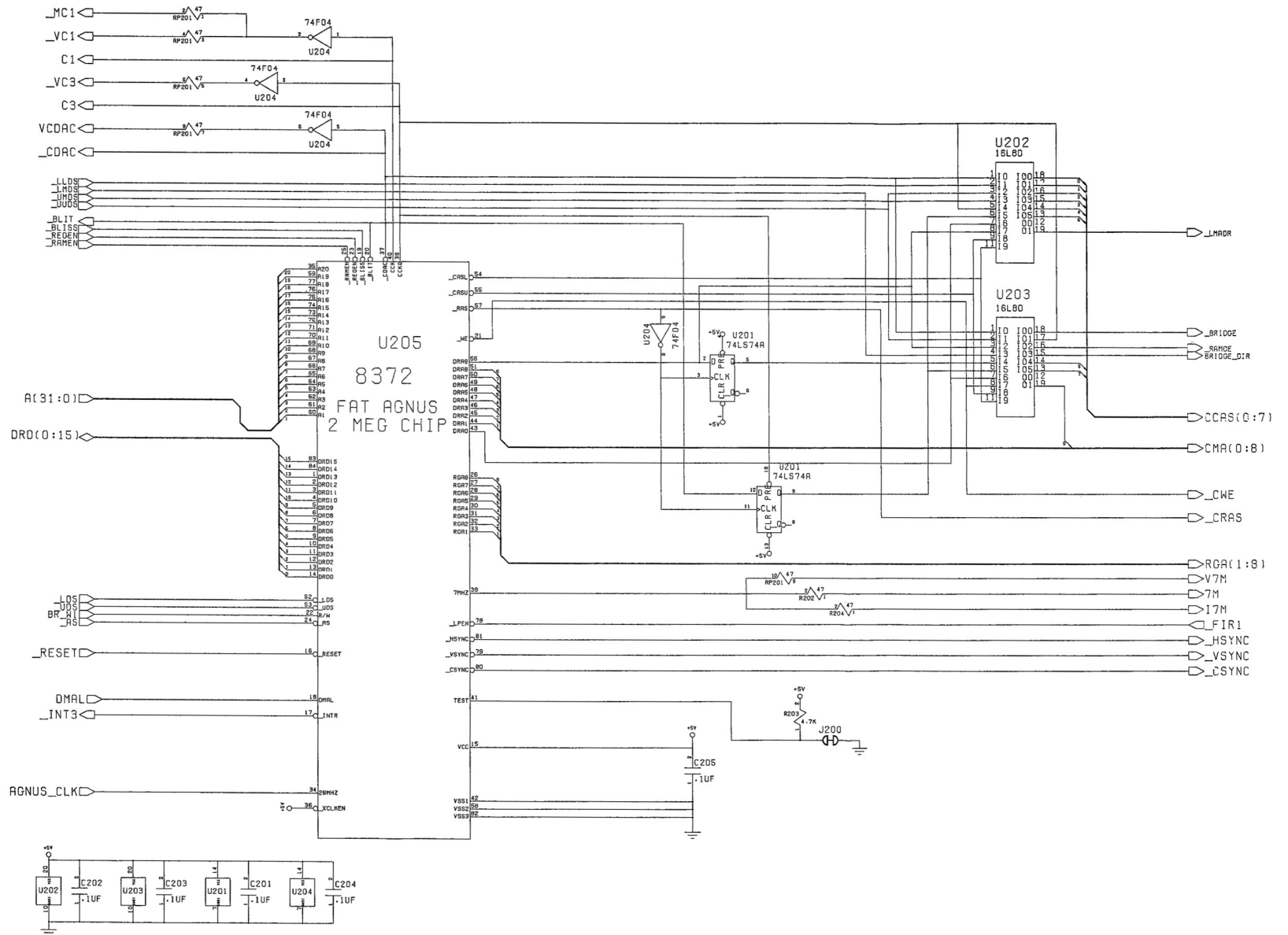

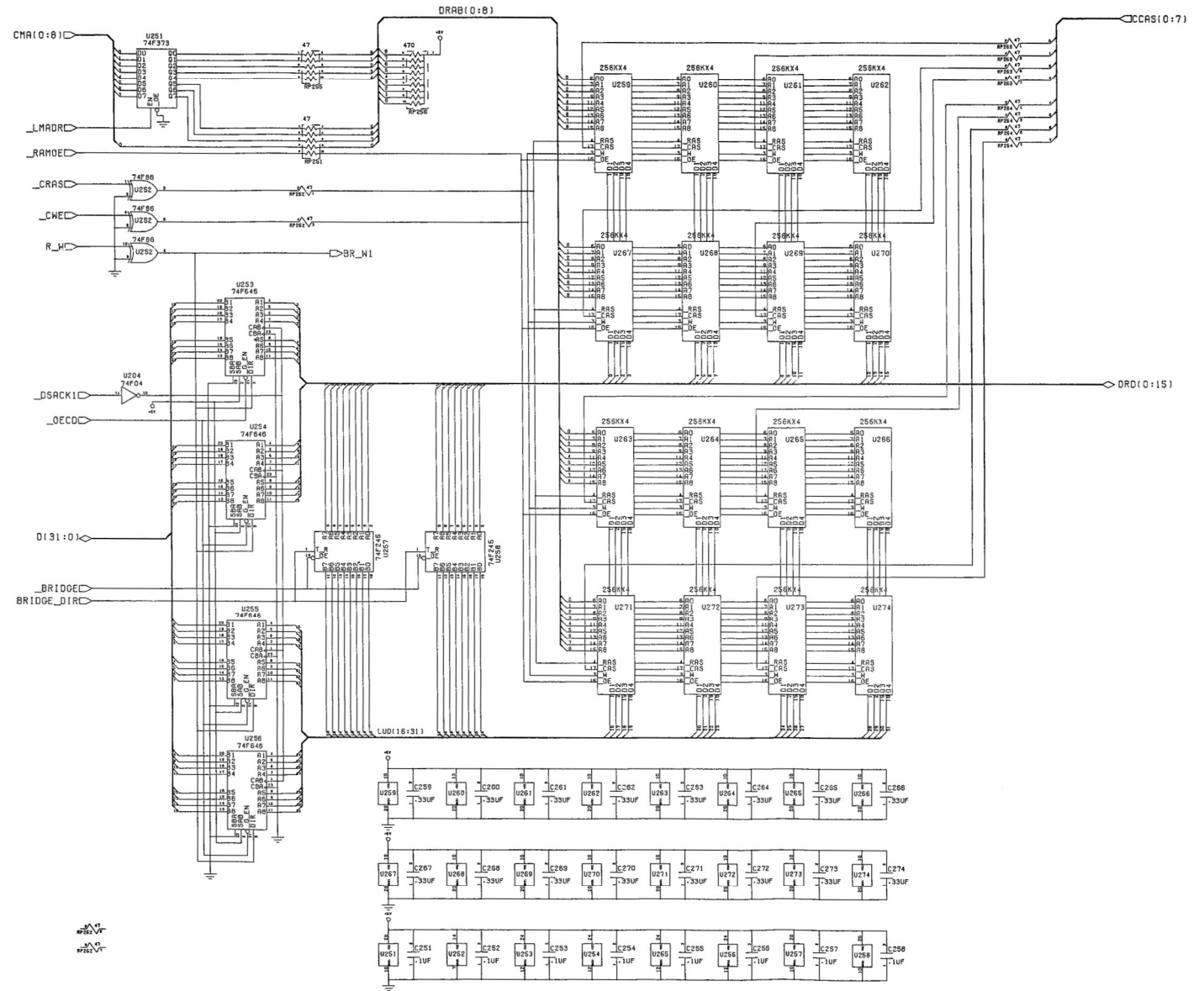

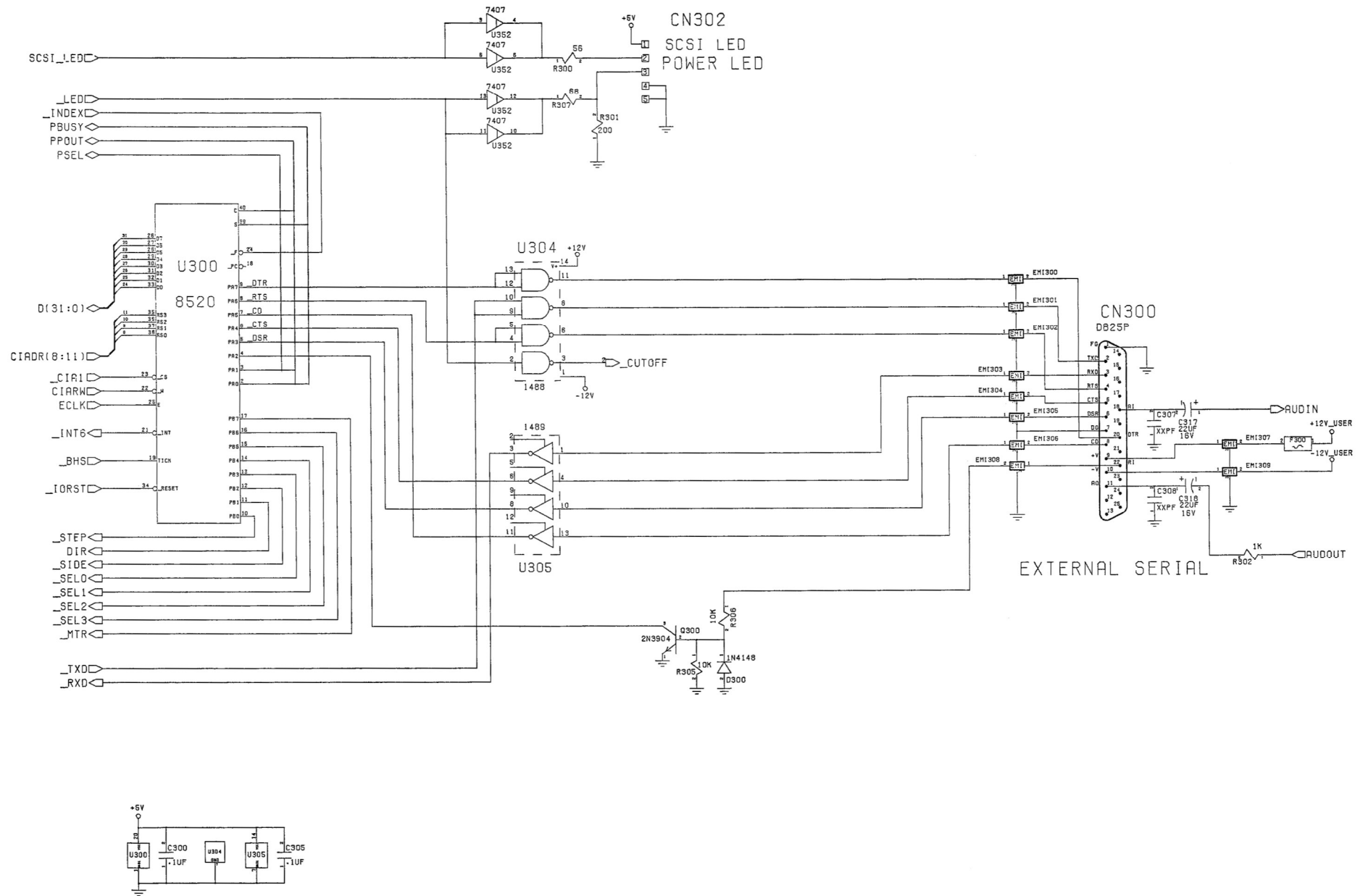

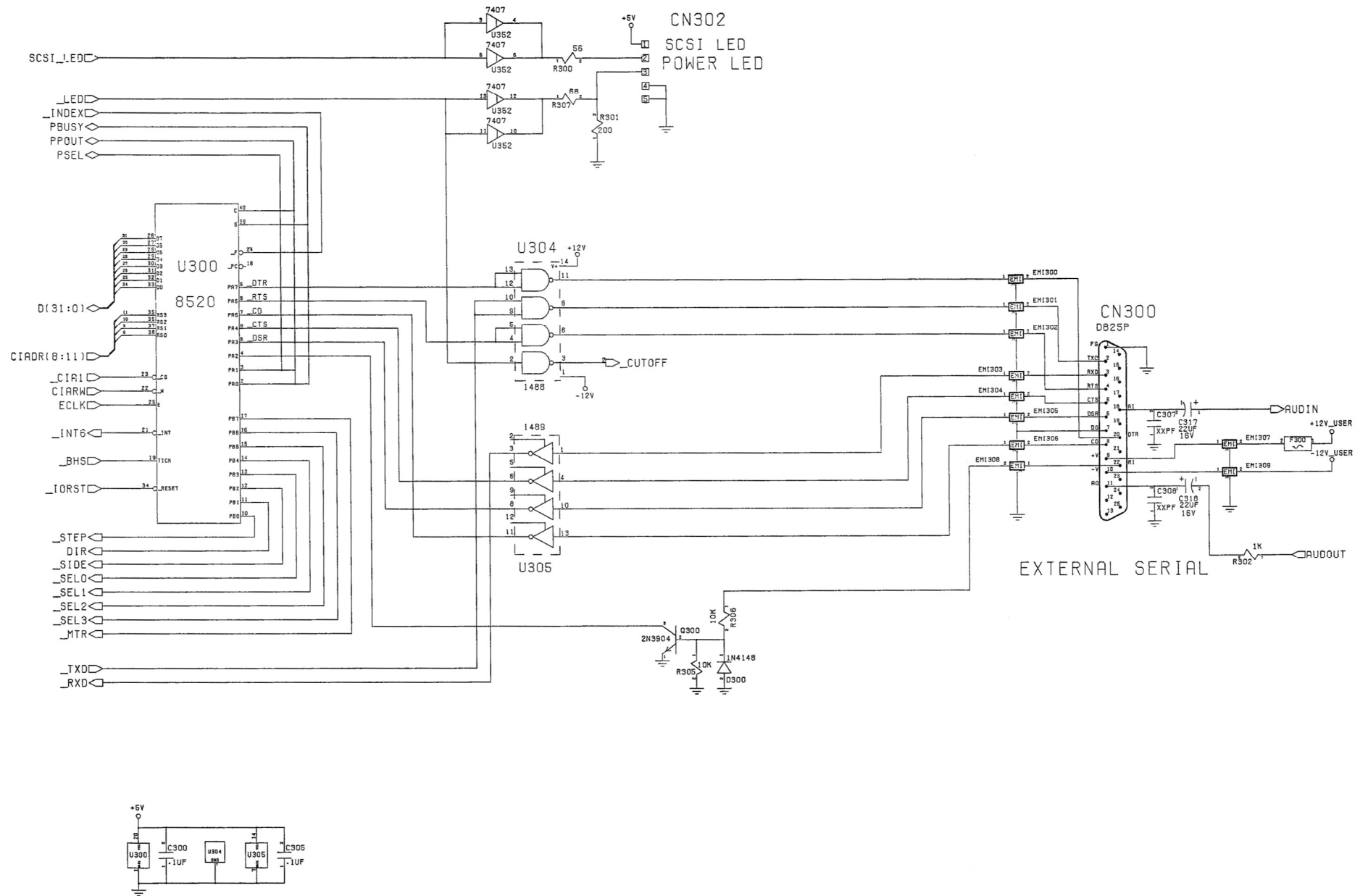

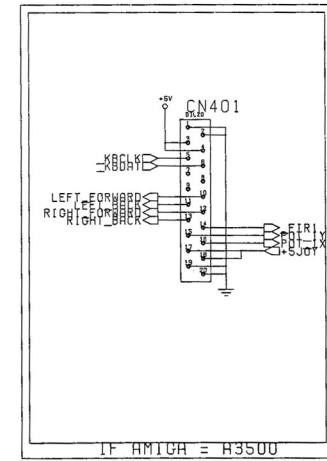
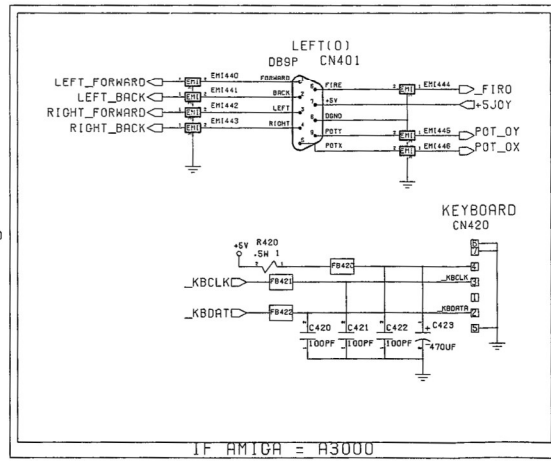
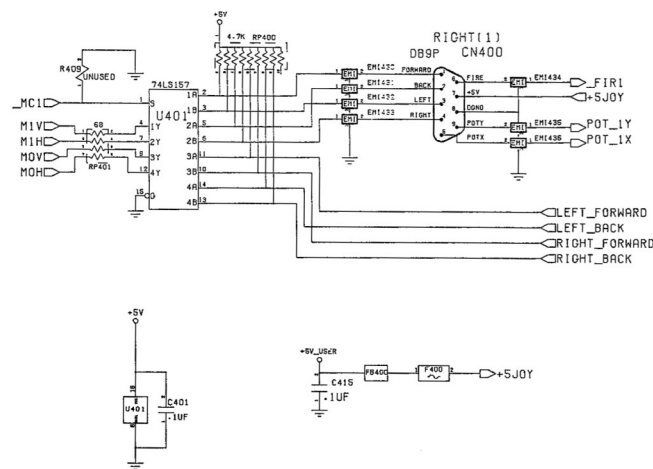
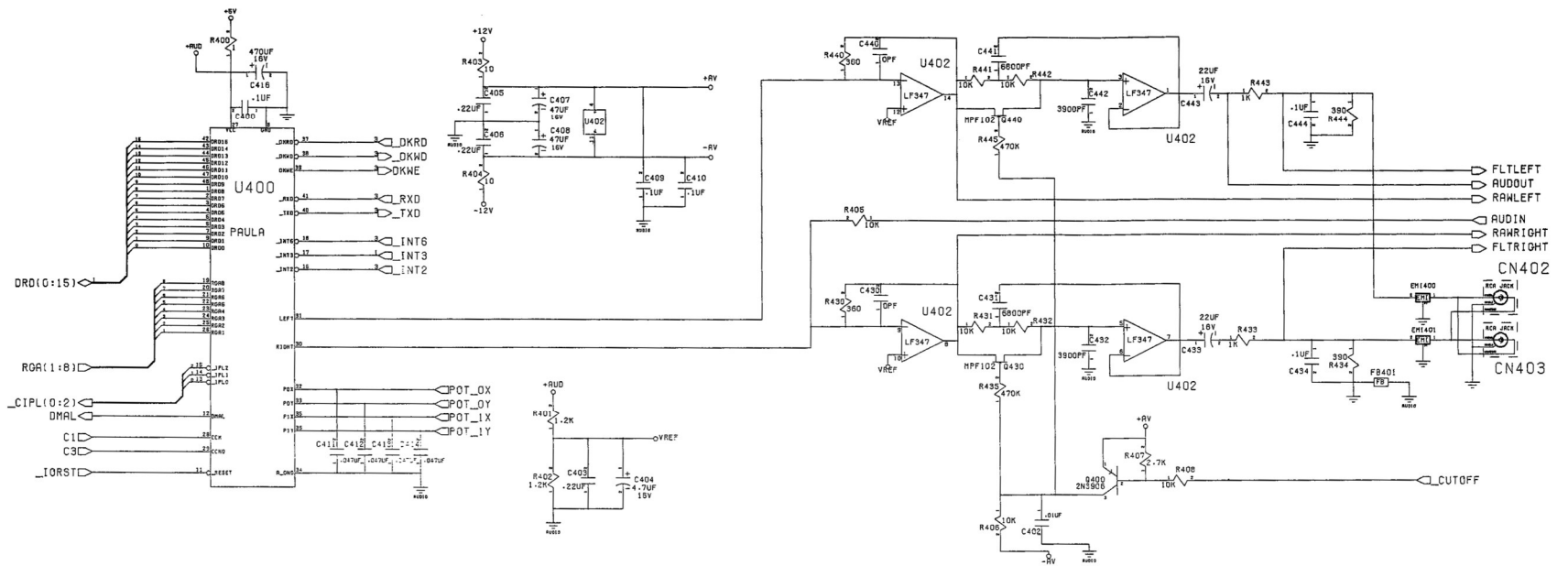

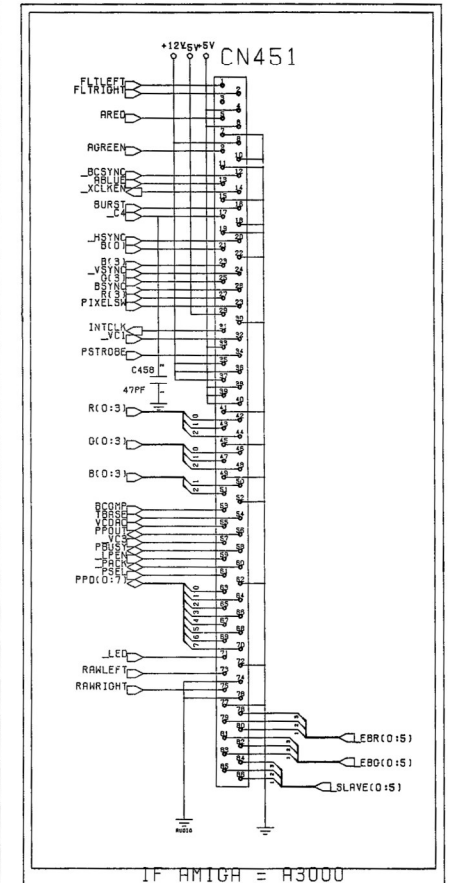
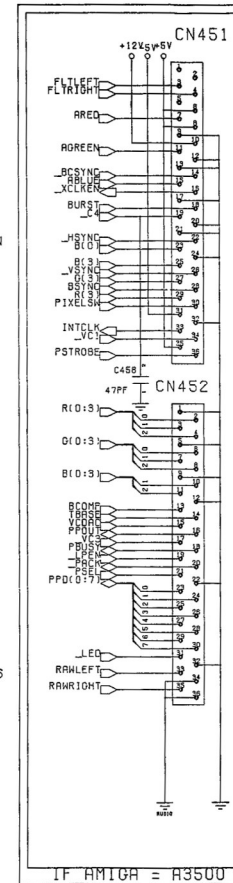
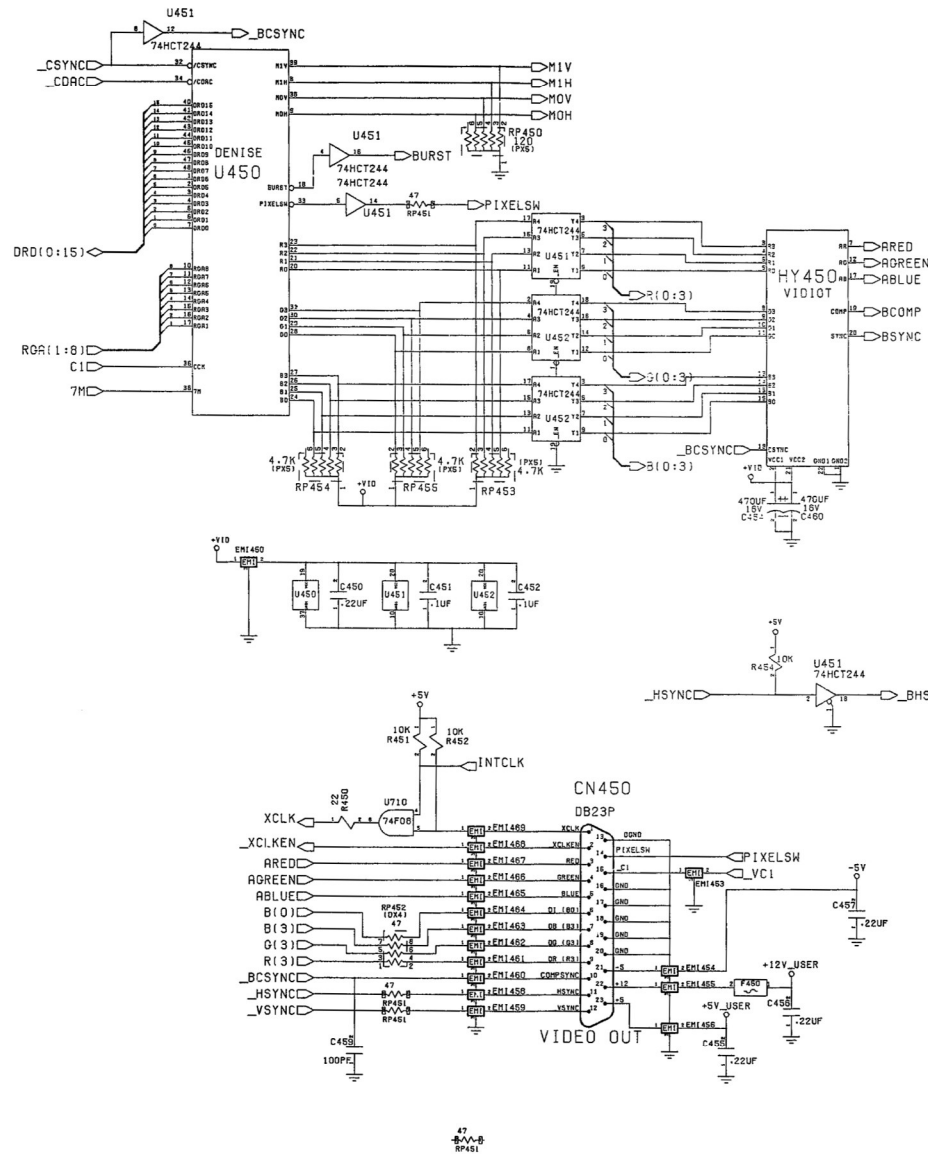

47
 RP451

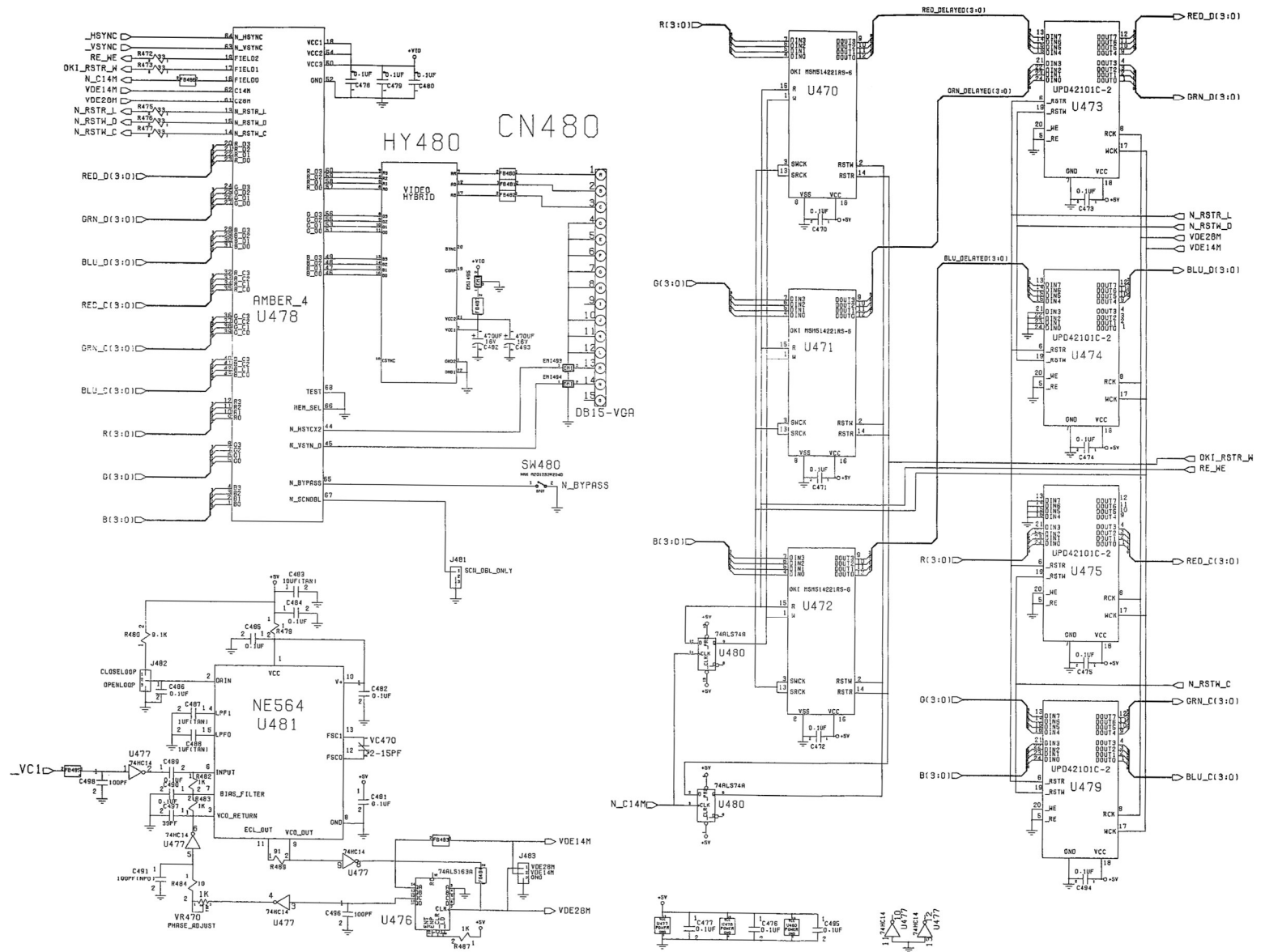

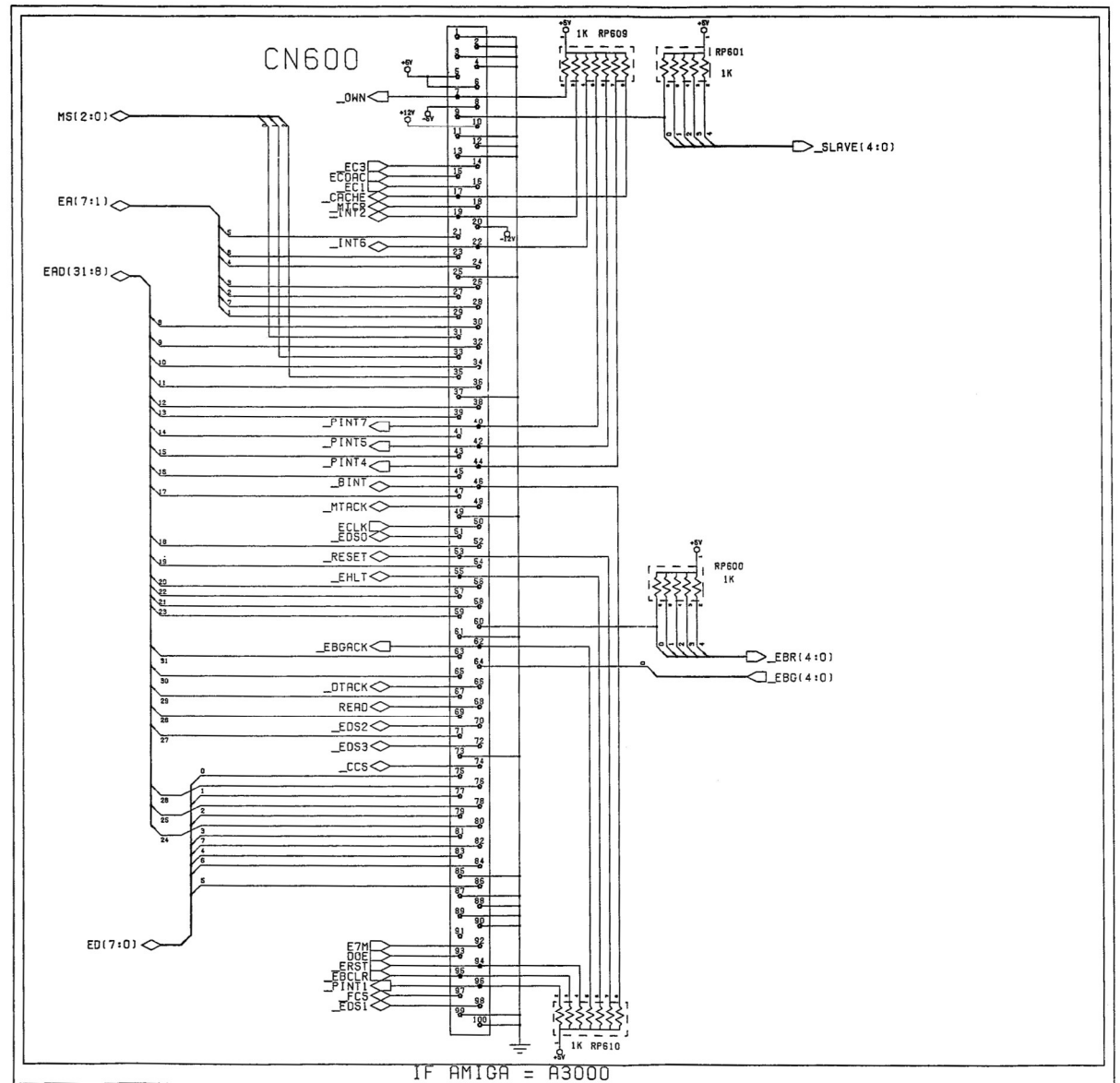

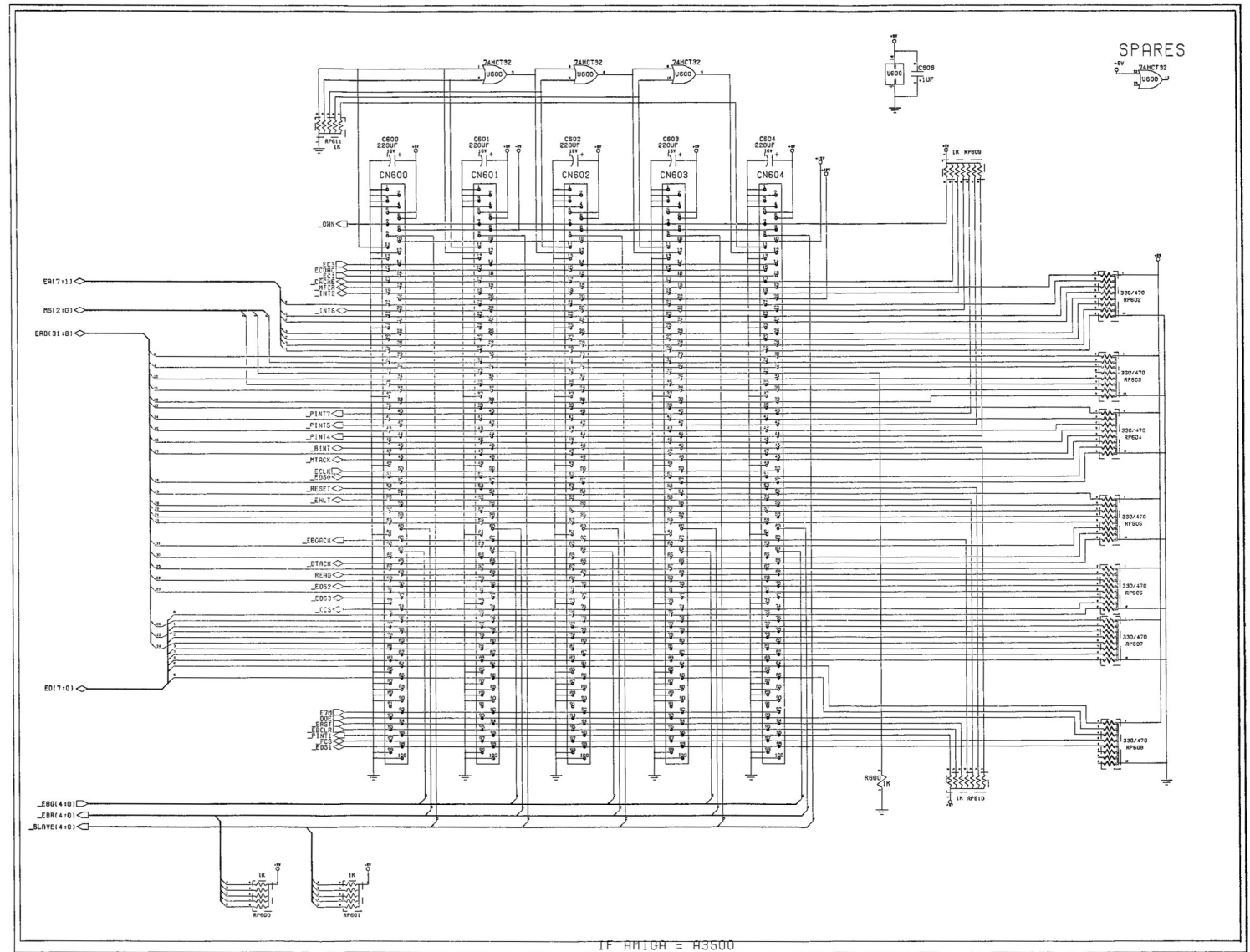

AMIGA 32 BIT LOCAL SLOT

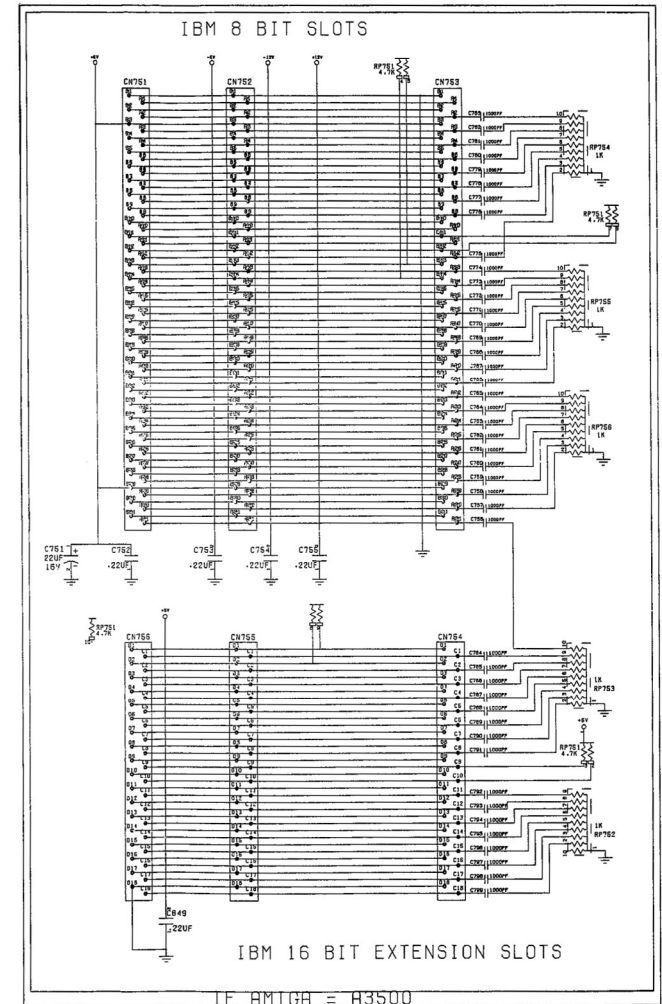
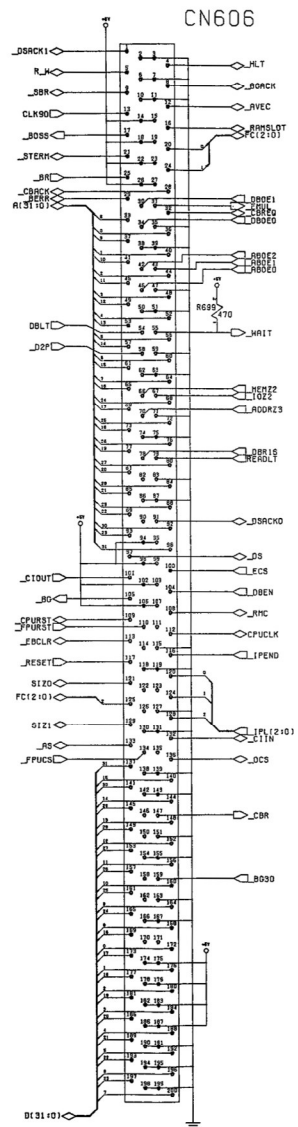

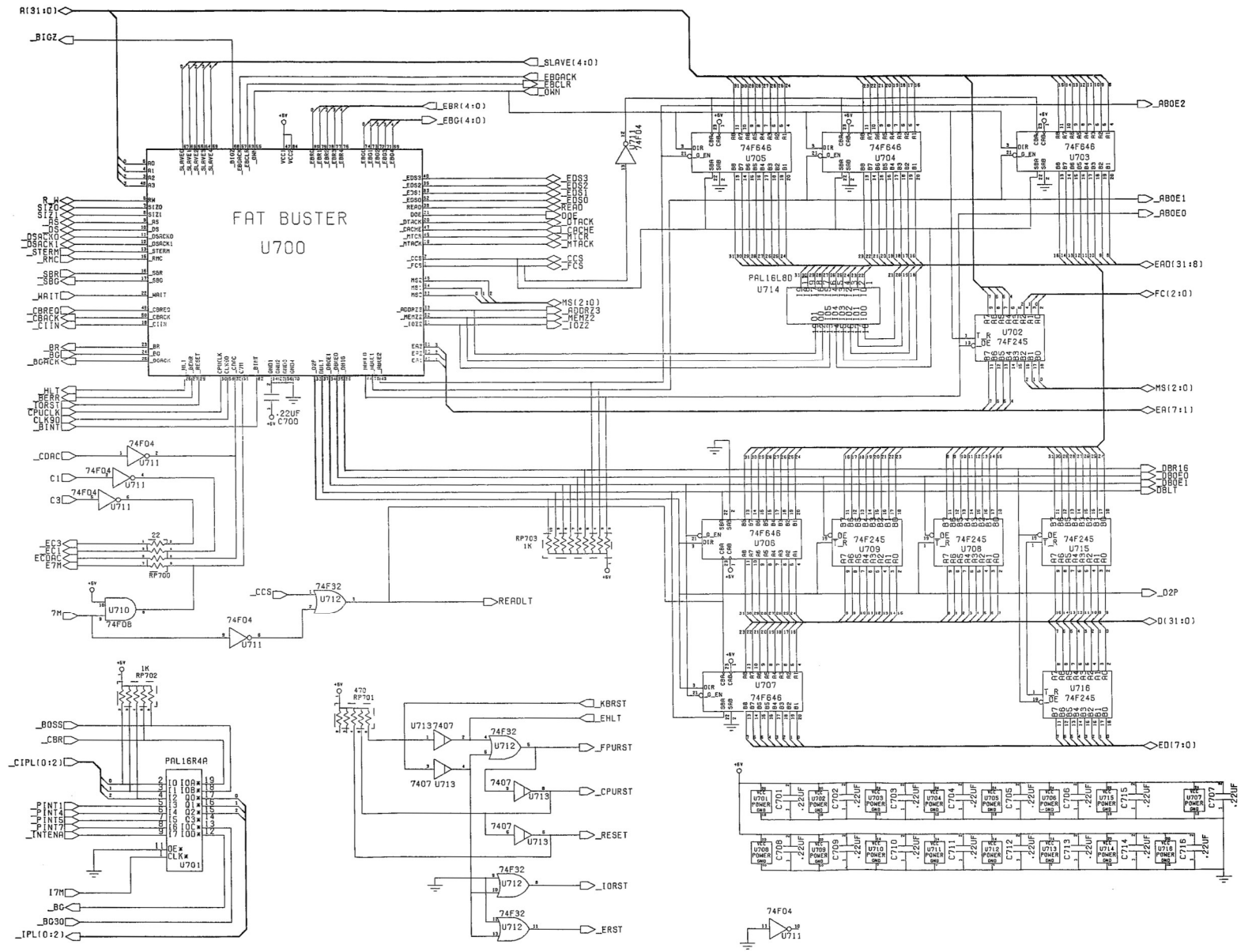

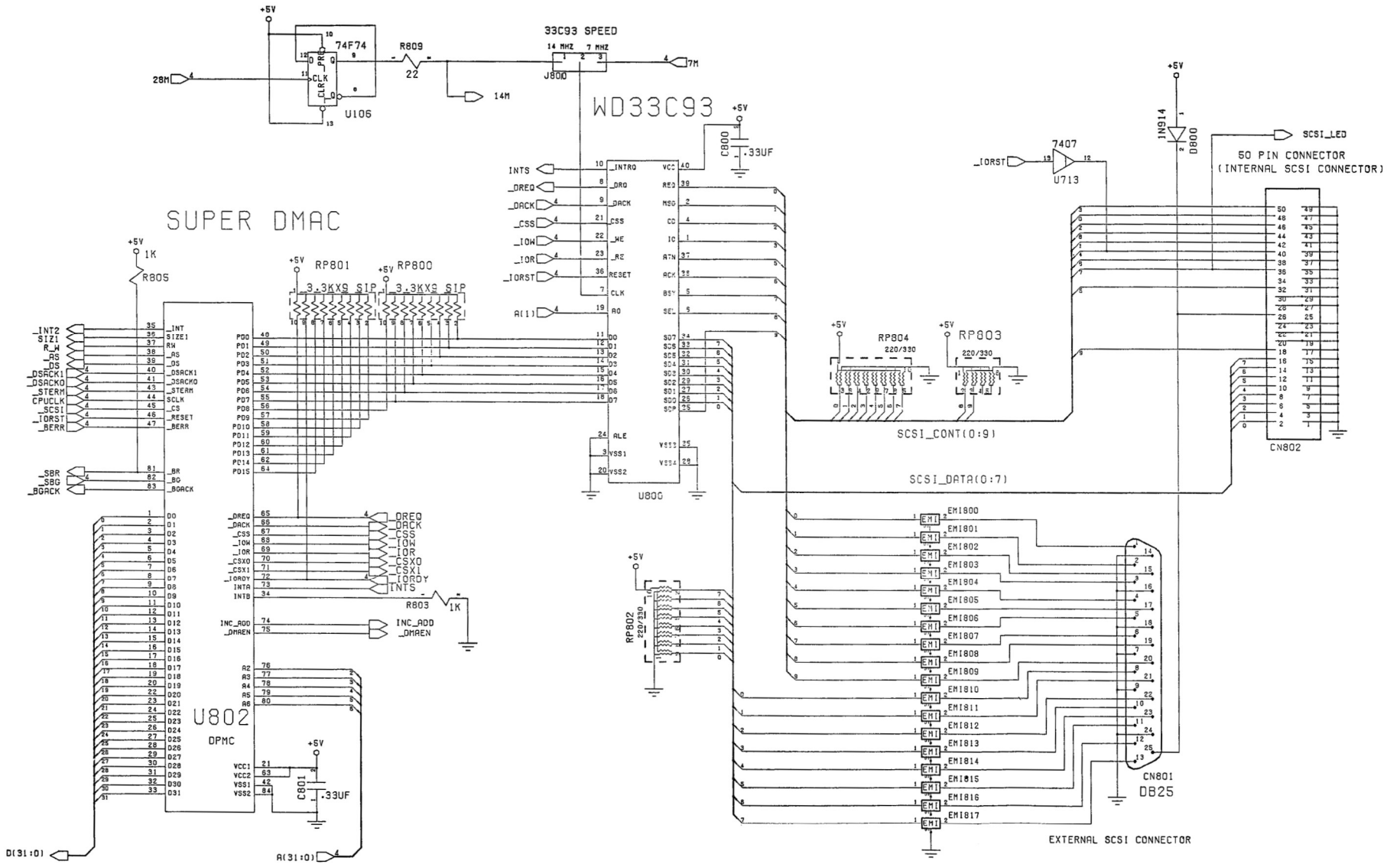

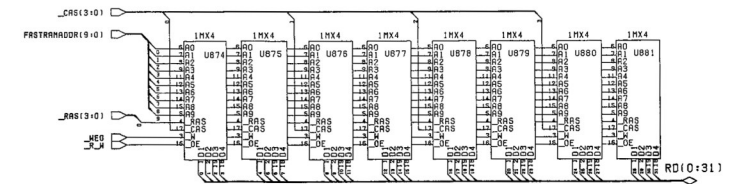
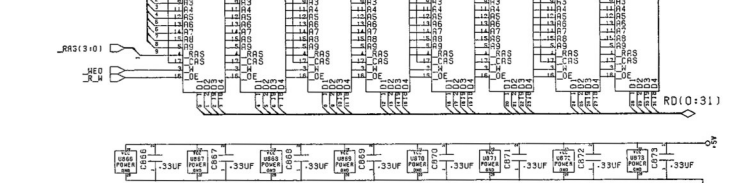
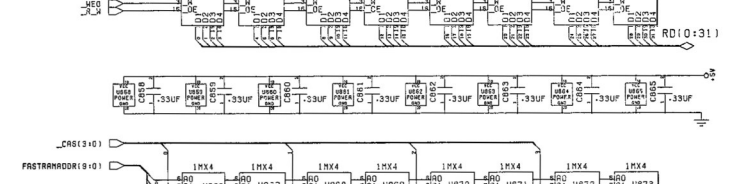
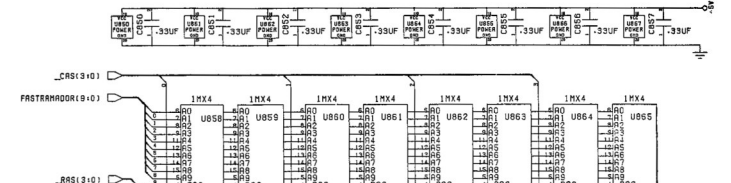
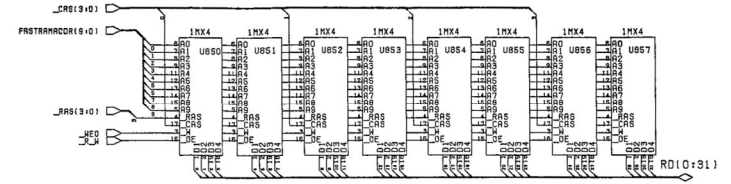
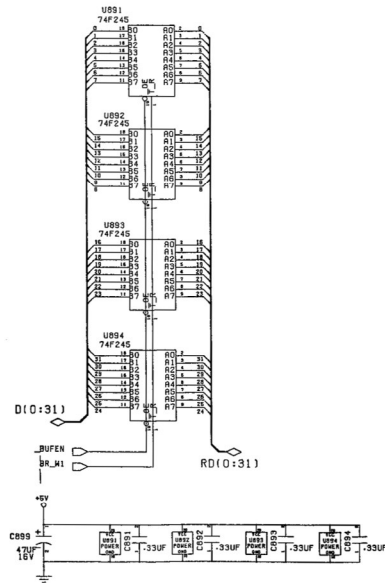
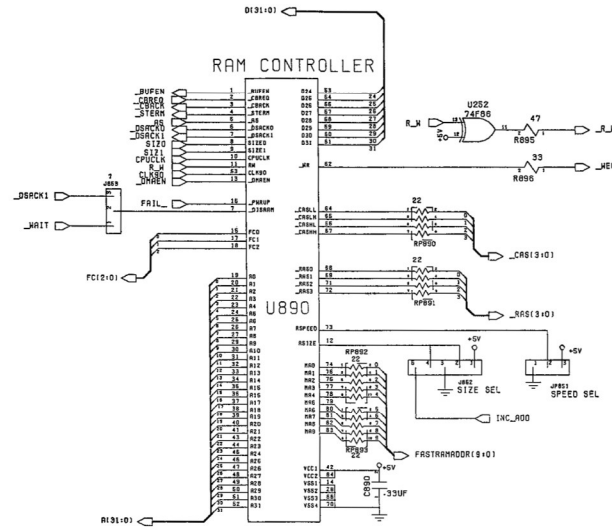

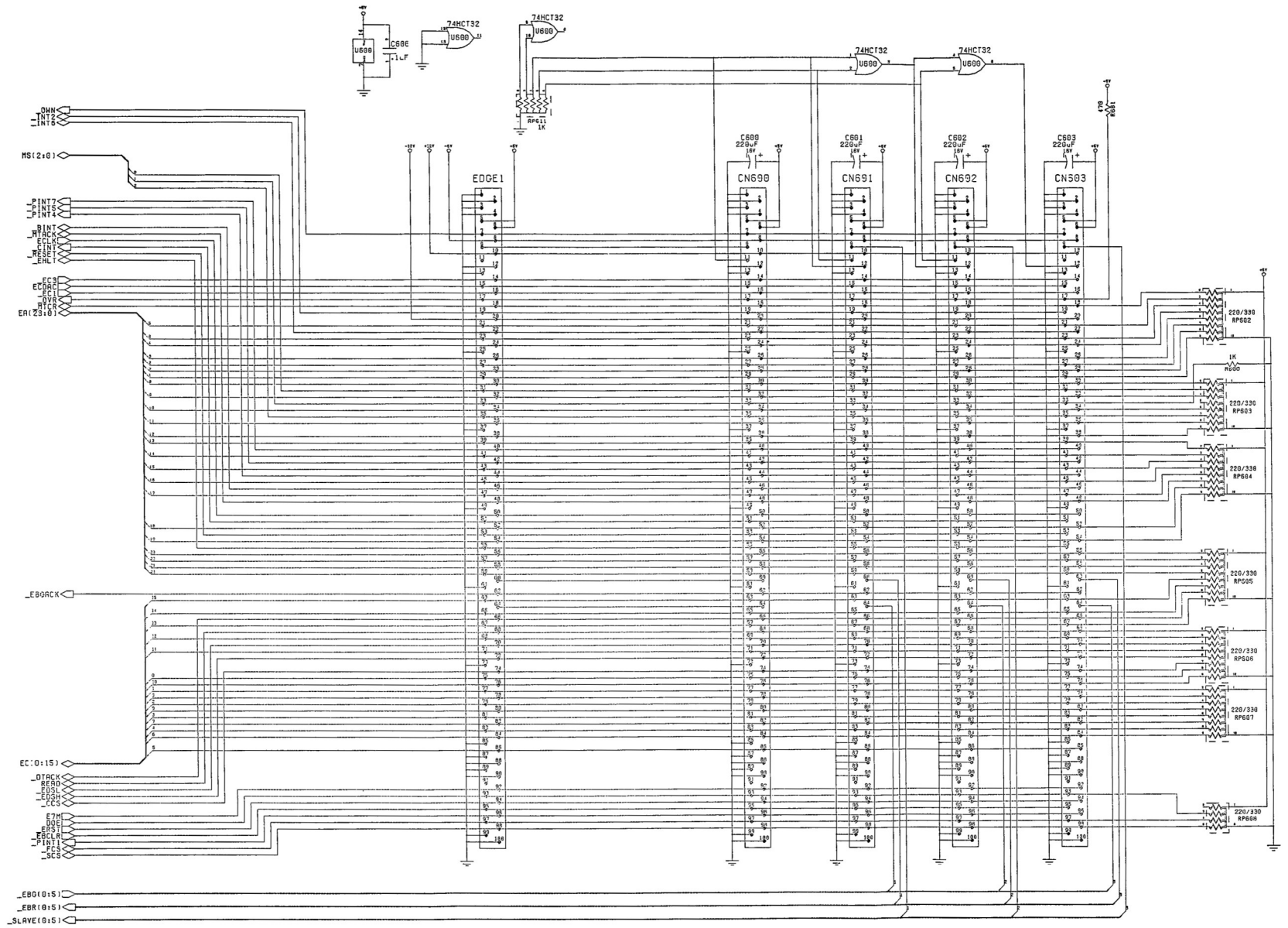

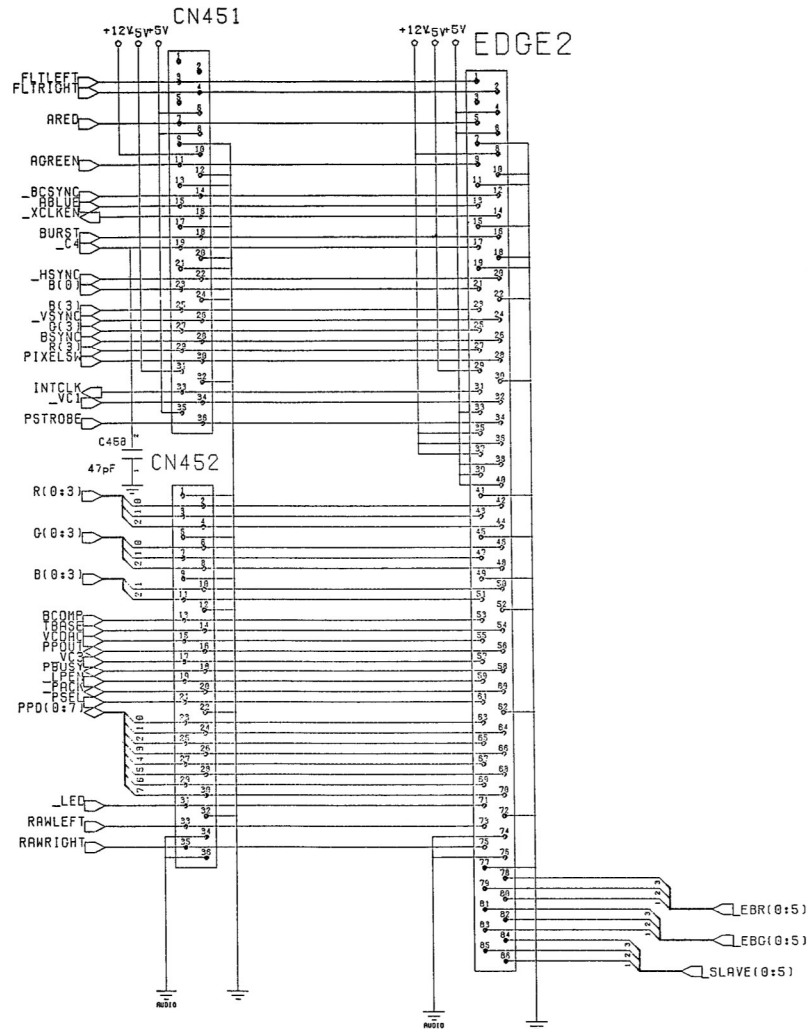

IBM 8 BIT SLOTS

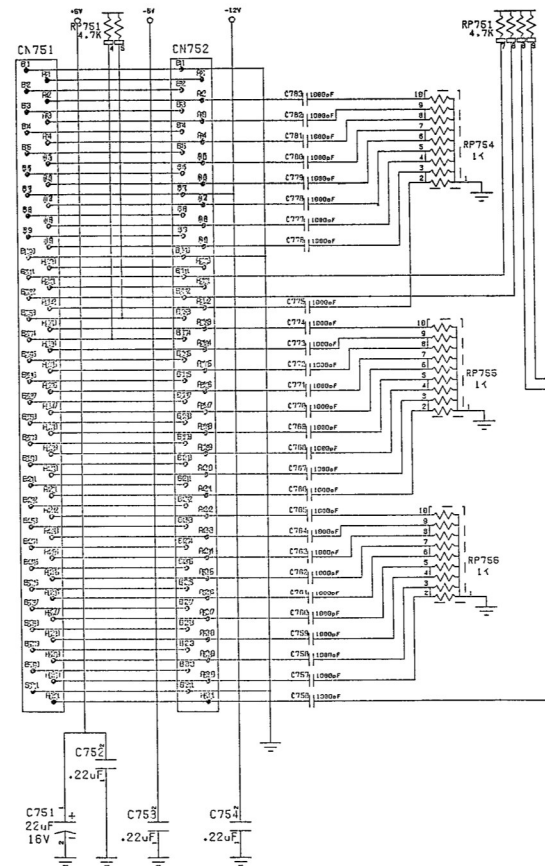

IBM 16 BIT EXTENSION SLOTS

