



Display

Date: **May 15, 2000**

Subject: **CONTROL PANEL LABEL**

Model: **PVM-14N5A, PVM-14N5E, PVM-14N5U, PVM-14N6A, PVM-14N6E, PVM-14N6U, SSM-14N5A, SSM-14N5E, SSM-14N5U**

Serial No: **SEE TEXT**

DESCRIPTION

The control panel label on the lower side of the front bezel may peel off. If this occurs, perform the following procedure.

SERIAL NUMBERS

PVM-14N6U	6,003,701–6,006,966
PVM-14N5U	6,006,932–6,012,841
PVM-14N6E	6,005,541–6,012,087
PVM-14N5E	6,005,167–6,009,433
PVM-14N6A	6,000,122–6,000,157
PVM-14N5A	6,000,515–6,000,621
SSM-14N5U	6,008,350–6,012,368
SSM-14N5E	6,006,555–6,010,326
SSM-14N5A	6,000,310–6,000,614

PARTS REQUIRED
PVM-14N6U, PVM-14N6E, PVM-14N6A

Part No.	Description	Qty.
4-050-088-02	Label, Control	1
7-600-007-54	Tape, Adhesive, Double-Sided 7.5mm x 50mm t=0.15mm	1

PARTS REQUIRED
PVM-14N5U, PVM-14N5E, PVM-14N5A

Part No.	Description	Qty.
4-050-088-12	Label, Control	1
7-600-007-54	Tape, Adhesive, Double-Sided 7.5mm x 50mm t=0.15mm	1

PARTS REQUIRED
SSM-14N5U, SSM-14N5E, SSM-14N5A

Part No.	Description	Qty.
4-050-088-22	Label, Control	1
7-600-007-54	Tape, Adhesive, Double-Sided 7.5mm x 500mm t=0.15mm	1

MODIFICATION PROCEDURE

1. Adhere double-sided adhesive tape in two locations on the back of the control panel label as shown in Figure 1.

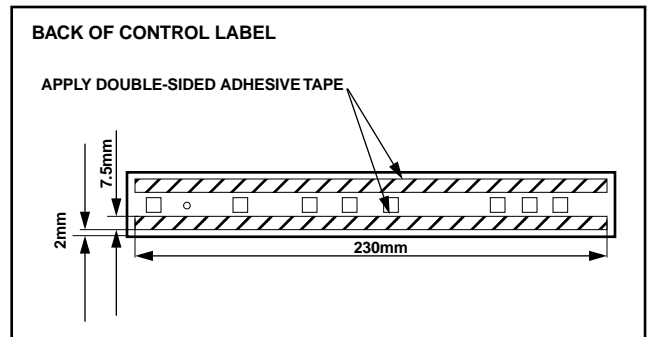

Figure 1

2. Carefully press the back of the control label onto the front of the unit in correct position.

INSPECTION PROCEDURE

3. Cut two pieces of white cloth tape (24mm wide) as follows:
 - 32mm x 24mm
 - 32mm x 8mm
4. Place the adhesive-side of the white cloth tape as shown in Figure 2.

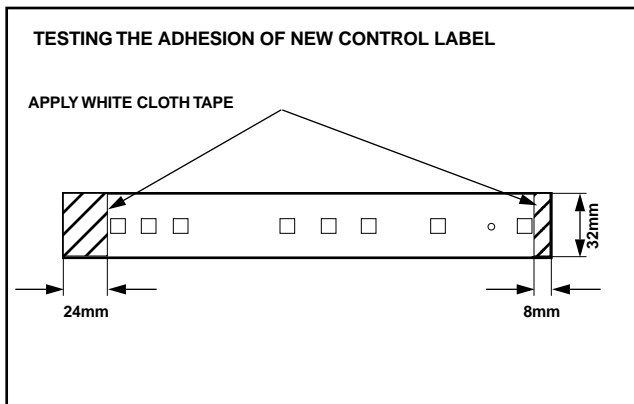

Figure 2

5. After pressing white cloth tape into place, peel it off to confirm that the control label stays in place.

NOTE: If the control label comes off with removal of the white cloth tape:

- Carefully remove the control label.
- Carefully peel the white cloth tape from the control label.
- Reattach the control label as shown in Figure 1.
- Repeat steps 3, 4, and 5.