

# Professional Video Monitor

## Operating Instructions

Before operating the unit, please read this manual thoroughly and retain it for future reference.

PVM-2541

PVM-1741

**TRIMASTER EL** **HDMI™**  
HIGH-DEFINITION MULTIMEDIA INTERFACE

## Owner's Record

The model and serial numbers are located at the rear. Record these numbers in the spaces provided below. Refer to these numbers whenever you call upon your Sony dealer regarding this product.

Model No. \_\_\_\_\_

Serial No. \_\_\_\_\_

### Important Safety Instructions

- Read these instructions.
- Keep these instructions.
- Heed all warnings.
- Follow all instructions.
- Do not use this apparatus near water.
- Clean only with dry cloth.
- Do not block any ventilation openings. Install in accordance with the manufacturer's instructions.
- Do not install near any heat sources such as radiators, heat registers, stoves, or other apparatus (including amplifiers) that produce heat.
- Do not defeat the safety purpose of the polarized or grounding-type plug. A polarized plug has two blades with one wider than the other. A grounding-type plug has two blades and a third grounding prong. The wide blade or the third prong are provided for your safety. If the provided plug does not fit into your outlet, consult an electrician for replacement of the obsolete outlet.
- Protect the power cord from being walked on or pinched particularly at plugs, convenience receptacles, and the point where they exit from the apparatus.
- Only use attachments/accessories specified by the manufacturer.
- Use only with the cart, stand, tripod, bracket, or table specified by the manufacturer, or sold with the apparatus.  When a cart is used, use caution when moving the cart/apparatus combination to avoid injury from tip-over.
- Unplug this apparatus during lightning storms or when unused for long periods of time.
- Refer all servicing to qualified service personnel. Servicing is required when the apparatus has been damaged in any way, such as power-supply cord or plug is damaged, liquid has been spilled or objects have fallen into the apparatus, the apparatus has been exposed to rain or moisture, does not operate normally, or has been dropped.

## WARNING

**To reduce the risk of fire or electric shock, do not expose this apparatus to rain or moisture.**

**To avoid electrical shock, do not open the cabinet. Refer servicing to qualified personnel only.**

**THIS APPARATUS MUST BE EARTHED.**

### WARNING

When installing the unit, incorporate a readily accessible disconnect device in the fixed wiring, or connect the power plug to an easily accessible socket-outlet near the unit. If a fault should occur during operation of the unit, operate the disconnect device to switch the power supply off, or disconnect the power plug.

### CAUTION

This Professional Video Monitor should only be used with a specified monitor stand. For information on suitable stands, refer to "Specifications." Installation of the Professional Video Monitor on any other stand may result in instability, possibly leading to injury.

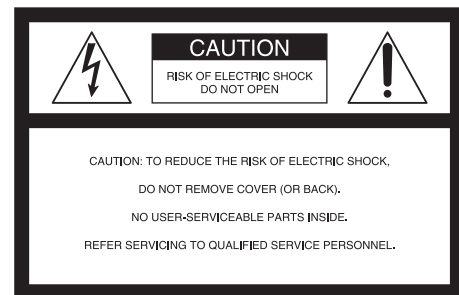

This symbol is intended to alert the user to the presence of uninsulated "dangerous voltage" within the product's enclosure that may be of sufficient magnitude to constitute a risk of electric shock to persons.



This symbol is intended to alert the user to the presence of important operating and maintenance (servicing) instructions in the literature accompanying the appliance.

### Attention-when the product is installed in Rack: (For PVM-1741)

#### 1. Prevention against overloading of branch circuit

When this product is installed in a rack and is supplied power from an outlet on the rack, please make sure that the rack does not overload the supply circuit.

## 2. Providing protective earth

When this product is installed in a rack and is supplied power from an outlet on the rack, please confirm that the outlet is provided with a suitable protective earth connection.

## 3. Internal air ambient temperature of the rack

When this product is installed in a rack, please make sure that the internal air ambient temperature of the rack is within the specified limit of this product.

## 4. Prevention against achieving hazardous condition due to uneven mechanical loading

When this product is installed in a rack, please make sure that the rack does not achieve hazardous condition due to uneven mechanical loading.

## 5. Install the equipment while taking the operating temperature of the equipment into consideration

For the operating temperature of the equipment, refer to the specifications of the Operation Manual.

## 6. When performing the installation, keep the following space away from walls in order to obtain proper exhaust and radiation of heat.

**Lower, Upper: 4.4 cm (1 3/4 inches) or more  
Right, Left: 1.0 cm (3/8 inches) or more**

**WARNING:** THIS WARNING IS APPLICABLE FOR USA ONLY.

If used in USA, use the UL LISTED power cord specified below.

DO NOT USE ANY OTHER POWER CORD.

Plug Cap	Parallel blade with ground pin (NEMA 5-15P Configuration)
Cord	Type SJT, three 16 or 18 AWG wires
Length	Minimum 1.5 m (4 ft. 11 in.), Less than 2.5 m (8 ft. 3 in.)
Rating	Minimum 10A, 125V

Using this unit at a voltage other than 120V may require the use of a different line cord or attachment plug, or both. To reduce the risk of fire or electric shock, refer servicing to qualified service personnel.

**WARNING:** THIS WARNING IS APPLICABLE FOR OTHER COUNTRIES.

1. Use the approved Power Cord (3-core mains lead) / Appliance Connector / Plug with earthing-contacts that conforms to the safety regulations of each country if applicable.
2. Use the Power Cord (3-core mains lead) / Appliance Connector / Plug conforming to the proper ratings (Voltage, Ampere).

If you have questions on the use of the above Power Cord / Appliance Connector / Plug, please consult a qualified service personnel.

## CAUTION

The apparatus shall not be exposed to dripping or splashing. No objects filled with liquids, such as vases, shall be placed on the apparatus.

## CAUTION

The unit is not disconnected from the AC power source (mains) as long as it is connected to the wall outlet, even if the unit itself has been turned off.

## WARNING

Excessive sound pressure from earphones and headphones can cause hearing loss.

In order to use this product safely, avoid prolonged listening at excessive sound pressure levels.

## For kundene i Norge

Dette utstyret kan kobles til et IT-strømfordelingssystem.

Apparatet må tilkoples jordet stikkontakt

## Suomessa asuville asiakkaille

Laite on liitettävä suojavaadoituskoskettimilla varustettuun pistorasiaan

## För kunderna i Sverige

Apparaten skall anslutas till jordat uttag

## For the customers in the U.S.A.

This equipment has been tested and found to comply with the limits for a Class A digital device, pursuant to Part 15 of the FCC Rules. These limits are designed to provide reasonable protection against harmful interference when the equipment is operated in a commercial environment. This equipment generates, uses, and can radiate radio frequency energy and, if not installed and used in accordance with the instruction manual, may cause harmful interference to radio communications. Operation of this equipment in a residential area is likely to cause harmful interference in which case the user will be required to correct the interference at his own expense.

You are cautioned that any changes or modifications not expressly approved in this manual could void your authority to operate this equipment.

All interface cables used to connect peripherals must be shielded in order to comply with the limits for a digital device pursuant to Subpart B of Part 15 of FCC Rules.

This device complies with Part 15 of the FCC Rules. Operation is subject to the following two conditions: (1) this device may not cause harmful interference, and (2) this device must accept any interference received, including interference that may cause undesired operation.

**For the customers in Canada**

This Class A digital apparatus complies with Canadian ICES-003.

**For the customers in Europe**

This product with the CE marking complies with the EMC Directive issued by the Commission of the European Community.

Compliance with this directive implies conformity to the following European standards:

- EN55103-1 : Electromagnetic Interference(Emission)
- EN55103-2 : Electromagnetic Susceptibility(Immunity)

This product is intended for use in the following Electromagnetic Environments: E1 (residential), E2 (commercial and light industrial), E3 (urban outdoors), E4 (controlled EMC environment, ex. TV studio).

The manufacturer of this product is Sony Corporation, 1-7-1 Konan, Minato-ku, Tokyo, 108-0075 Japan.

The Authorized Representative for EMC and product safety is Sony Deutschland GmbH, Hedelfinger Strasse 61, 70327 Stuttgart, Germany. For any service or guarantee matters please refer to the addresses given in separate service or guarantee documents.

---

# Table of Contents

<b>Precaution</b> .....	<b>6</b>
On Safety .....	6
On Installation .....	6
Handling the Screen .....	6
On Burn-in .....	6
On a Long Period of Use .....	6
Handling and Maintenance of the Screen .....	7
On Dew Condensation .....	7
On Repacking .....	7
Disposal of the Unit .....	7
On Fan Error .....	7
<b>Features</b> .....	<b>8</b>
<b>Location and Function of</b>	
<b>Parts and Controls</b> .....	<b>10</b>
Front Panel .....	10
Input Signals and Adjustable/Setting Items .....	12
Rear Panel .....	13
<b>Removing the Monitor Stand (Pre-Attached) ...</b>	<b>15</b>
<b>Installing on a Rack (PVM-1741 only) .....</b>	<b>15</b>
<b>Adjusting the Height of the Monitor</b>	
<b>(with SU-561 only) .....</b>	<b>16</b>
<b>Connecting the AC Power Cord .....</b>	<b>17</b>
<b>Selecting the Default Settings .....</b>	<b>18</b>
<b>Selecting the Menu Language .....</b>	<b>19</b>
<b>Using the Menu .....</b>	<b>20</b>
<b>Adjustment Using the Menus .....</b>	<b>22</b>
Items .....	22
Adjusting and Changing the Settings .....	23
STATUS menu.....	23
COLOR TEMP/SPACE menu .....	23
USER CONTROL menu.....	24
USER CONFIG menu.....	25
REMOTE menu .....	32
KEY INHIBIT menu.....	34
<b>Troubleshooting .....</b>	<b>34</b>
<b>Specifications .....</b>	<b>35</b>
<b>Dimensions .....</b>	<b>38</b>

---

# Precaution

---

## On Safety

- Operate the unit only with a power source as specified in the “Specifications” section.
- A nameplate indicating operating voltage, power consumption, etc., is located on the rear panel.
- Should any solid object or liquid fall into the cabinet, unplug the unit and have it checked by qualified personnel before operating it any further.
- Do not drop or place heavy objects on the power cord. If the power cord is damaged, turn off the power immediately. It is dangerous to use the unit with a damaged power cord.
- Unplug the unit from the wall outlet if it is not to be used for several days or more.
- Disconnect the power cord from the AC outlet by grasping the plug, not by pulling the cord.
- The socket-outlet shall be installed near the equipment and shall be easily accessible.

---

## On Installation

- Allow adequate air circulation to prevent internal heat build-up.  
Do not place the unit on surfaces (rugs, blankets, etc.) or near materials (curtains, draperies) that may block the ventilation holes.
- Do not install the unit in a location near heat sources such as radiators or air ducts, or in a place subject to direct sunlight, excessive dust, mechanical vibration or shock.

When installing the installation space must be secured in consideration of the ventilation and service operation.

- Do not block the ventilation slots, and vents of the fans.
- Leave a space around the unit for ventilation.
- Leave more than 40 cm of space in the rear of the unit to secure the operation area.

When the unit is installed on the desk or the like, leave at least 1U (4.4cm) or more of space above and below the unit. Leaving 40 cm or more of space above the unit is recommended for service operation.

---

## Handling the Screen

- The panel fitted to this unit is manufactured with high precision technology, giving a functioning pixel ratio of at least 99.99%. Thus a very small proportion of pixels may be “stuck”, either always off (black),

always on (red, green, or blue), or flashing. In addition, over a long period of use, because of the physical characteristics of the panel, such “stuck” pixels may appear spontaneously. These problems are not a malfunction.

- Do not leave the screen facing the sun as it can damage the screen. Take care when you place the unit by a window.
- Do not push or scratch the monitor’s screen. Do not place a heavy object on the monitor’s screen. This may cause the screen to lose uniformity.
- The screen and the cabinet become warm during operation. This is not a malfunction.

---

## On Burn-in

Due to the characteristics of the material used in the OLED panel for its high-precision images, permanent burn-in may occur if still images are displayed in the same position on the screen continuously, or repeatedly over extended periods.

Images that may cause burn-in

- Masked images with aspect ratios other than 16:9
- Color bars or images that remain static for a long time
- Character or message displays that indicate settings or the operating state
- On-screen displays such as center markers or area markers

### To reduce the risk of burn-in

- Turn off the character and marker displays  
Press the MENU button to turn off the character displays. To turn off the character or marker displays of the connected equipment, operate the connected equipment accordingly. For details, refer to the operation manual of the connected equipment.
- Turn off the power when not in use  
Turn off the power if the viewfinder is not to be used for a prolonged period of time.

### Screen saver

This product has a built-in screen saver function to reduce burn-in. When an almost still image is displayed for more than 10 minutes, the screen saver starts automatically and the brightness of the screen decreases.

---

## On a Long Period of Use

Due to an OLED’s panel structure and characteristics of materials in its design, displaying static images for extended periods, or using the unit repeatedly in a high temperature/high humidity environments may cause image smearing, burn-in, areas of which brightness is permanently changed, lines, or a decrease in overall brightness.

In particular, continued display of an image smaller than the monitor screen, such as in a different aspect ratio, may shorten the life of the unit.

Avoid displaying a still image for an extended period, or using the unit repeatedly in a high temperature/high humidity environment such as an airtight room, or around the outlet of an air conditioner.

To prevent any of the above issues, we recommend reducing brightness slightly, and to turn off the power whenever the unit is not in use.

---

## Handling and Maintenance of the Screen

The surface of the screen is specially coated to reduce image reflection. Make sure to observe the following points as improper maintenance procedures may impair the screen's performance. In addition, the screen is vulnerable to damage. Do not scratch or knock against it using a hard object.

- Be sure to disconnect the AC power cord from the AC outlet before performing maintenance.
- The surface of the screen is specially coated. Do not attach adhesive objects, such as stickers, on it.
- The surface of the screen is specially coated. Do not touch the screen directly.
- Wipe the screen surface gently with the supplied cleaning cloth or a soft dry cloth to remove dirt.
- Stubborn stains may be removed with the supplied cleaning cloth, or a soft cloth slightly dampened with a mild detergent solution.
- The screen may become scratched if the cleaning cloth is dusty.
- Never use strong solvents such as alcohol, benzene, thinner, acidic or alkaline detergent, detergent with abrasives, or chemical wipe as these may damage the screen.
- Use a blower to remove dust from the screen surface.

---

## On Dew Condensation

If the viewfinder is moved suddenly from a cold place to a warm place, or used in a room with high humidity, water droplets may form on the interior of the product. This phenomenon is known as dew condensation.

This product does not come with a feature that warns users of dew condensation. If water droplets are found on the casing, turn off the power, and wait until the condensation disappears before using.

---

## On Repacking

Do not throw away the carton and packing materials. They make an ideal container which to transport the unit.

---

## Disposal of the Unit

Do not dispose of the unit with general waste. Do not include the monitor with household waste. When you dispose of the monitor, you must obey the law in the relative area or country.

---

## On Fan Error

The fan for cooling the unit is built in. When the fan stops and the  (standby) switch indicator on the front panel blinks in green and amber for fan error indication, turn off the power and contact an authorized Sony dealer.

### About this manual

The instructions in this manual are for the following two models:

- PVM-2541
- PVM-1741

The illustration of PVM-2541 is used for the explanations. Any differences in specifications are clearly indicated in the text.

# Features

The PVM-2541 (25-type) or PVM-1741 (17-type) Professional Video Monitor is a high performance color video monitor. This is suitable for television stations or video production houses, where precise image reproduction is required.

It features OLED panel and “TRIMASTER<sup>1)</sup>,” which is a new technology developed for three elements, “accurate color reproduction,” “precision imaging” and “quality picture consistency,” that are in demand for professional use. “TRIMASTER” decreases the viewing difference that occurs due to the individuality of each panel. Also, it realizes the high picture quality and high-trust required for the professional video monitor by the color management system with its wide color gamut device, high-resolution/precise gradation display, highly accurate signal processing and panel correction function.

<sup>1)</sup> TRIMASTER is a trademark of Sony Corporation.

## Advantages of OLED panel technology

The OLED panel makes use of an organic material, which emits light when an electric current is applied. Being self-emitting, the strength of luminescence can be controlled by the amount of electric current. This brings about the following three features:

Quick motion picture response:

The luminescent state of the OLED panel can be changed instantaneously by changing the current flow in the organic material. This enables a quick motion picture response and production of images with minimal blurring and ghosting. Furthermore, performance for shooting on location is not influenced by changes in environmental temperature.

High contrast and wide dynamic range:

The OLED panel does not emit light when black signal is applied to the monitor, enabling a pure black screen to be displayed. Furthermore, thanks to a wide dynamic range the panel impressively displays brilliance and clarity of various sparkling images, such as stars in a night sky twinkling, night illuminations winking or glass glittering, etc.

Rich color reproduction:

An OLED panel’s self-luminescence also allows for great color reproduction across the entire spectrum in practically any shade or brightness.

## Sony’s Super Top Emission<sup>2)</sup> OLED panel

Both 17-type and 25-type models include a full HD (1920 × 1080) OLED panel featuring Sony’s Super Top Emission technology. Unlike the conventional bottom

emission structure of TFT, Sony’s OLED panel can reproduce a crisper image due to high brightness. Furthermore, a unique microcavity structure makes RGB primary colors purer and deeper by utilizing light resonance effects that magnify optimum light wave lengths and diminish undesired light wave lengths. The panel’s 10-bit driver enables smooth gradation of color shading.

<sup>2)</sup> “Super Top Emission” is a trademark that represents the OLED technology of Sony Corporation.

## Lightweight and durable monitor housing

A lightweight and durable aluminum housing suitable for wall and rack mounting is employed. It lightens the load on your broadcasting van and saves space.

## External remote function

The input signal is selected (or various items adjusted) by the serial (Ethernet) remote function. Up to 32 monitors and control units (max. 4) can be connected by the Ethernet (10BASE-T/100BASE-TX) connection and controlled remotely on the network. You can control individual monitors or monitor groups simply by entering the monitor ID or group ID number. You can also execute the same operation on all connected monitors, or put all connected monitors into the same setup and adjustment state.

*For more information, see SERIAL REMOTE of the REMOTE menu on page 33.*

*Refer to the Operation Manual of the BKM-15R or BKM-16R Monitor Control Unit (optional).*

## Input signal waveform, audio level, and vectorscope display

The input signal waveform, the audio level (embedded audio only), or the vectorscope can be displayed.

*For more information, see “WFM/ALM/VECTOR (waveform monitor, audio level meter, and vectorscope) SETTING” on page 27.*

## Timecode display

Timecode superimposed on SDI signals is displayed on the screen.

*For more information, see T/C (time code) DISPLAY SETTING on page 27.*

## Camera focus

This function sharpens the edges of the image more than the amount set by the upper limit of the aperture value in the USER CONTROL menu.

This is convenient for focusing with the camera. This function also colors the focused part of an image, providing fast and exact focusing.



### **I/P mode select**

The desired I/P mode for interlace signal can be selected for your purpose.

*For more information, see SYSTEM SETTING on page 25.*

### **Color space function**

You can select any of three color space settings (EBU/SMPTE-C/ITU-R BT.709).

### **Gamma adjustment function**

You can select the gamma mode from among 2.4, 2.2, and CRT.

### **Selecting marker/scan display**

Various items for broadcast use can be displayed. The center marker, safe area marker, aspect marker or display size (scan), etc., are displayed by selecting according to use.

*For more information, see MARKER SETTING on page 27, and see SCAN of FUNCTION BUTTON SETTING on page 29.*

### **Scan setting/native display**

When video signals are input, you can set the display size to 0% scan (normal) or 5% over scan (over). A native display function that maps the pixel of the signal to the panel in one-to-one mode is also equipped. Scaling to correct the screen aspect ratio is done to the horizontal direction of SD signals with non-square pixels (number of horizontal pixels of the signal system is 720 or 1440) or 640 × 480 SD signal of HDMI video.

### **Closed caption**

The EIA/CEA-608 and EIA/CEA-708 standard closed caption signals superimposed on an SDI signal are displayed.

### **Key inhibit function**

You can inhibit a key function to prevent missing an operation.

### **Illuminated control panel**

The characters that represent the names of the buttons on the control panel can be illuminated, so it is visible in the dark. The brightness of the LED has two levels, and varies according to the ambient light.

### **Screen saver**

To reduce burn-in, the brightness of the screen can be automatically decreased when a still image is displayed for more than 10 minutes.

### **Rack mount**

PVM-2541 and PVM-1741 support the VESA (100 × 100) standard. The PVM-1741 can also be mounted on an EIA-standard 19-inch rack.

*For more information, see “Installing on a Rack (PVM-1741 only)” on page 15.*

Consult with Sony qualified personnel for wall mount installation.

### **Monitor stand with tilt function**

PVM-2541 and PVM-1741 can be mounted on the optional SU-561 Monitor Stand with tilt and height adjustment. You can select the height of the monitor by adjusting the stand.

*For more information, see “Adjusting the Height of the Monitor (with SU-561 only)” on page 16.*

# Location and Function of Parts and Controls

## Front Panel

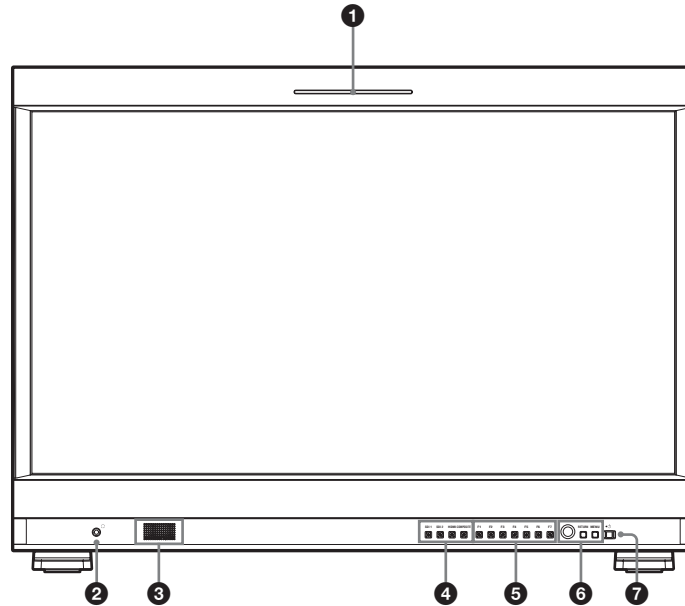

### 1 Tally lamp

You can check the status of the monitor by the color of the tally lamp.

The tally lamp lights in red, green or amber according to the setting of PARALLEL REMOTE in the REMOTE menu.

### 2 (headphones) jack

The audio signal which is selected by the input select button is output in stereo sound.

### 3 Speaker

The audio signal which is selected by the input select button is output in monaural sound (L + R).

When SDI signals are input, the audio which is selected in AUDIO SETTING of the USER CONFIG menu is output (see page 31).

The audio signals from the speaker are output from the AUDIO OUT connector on the rear (see page 14).

Audio signals will not be output when headphones are connected to the (headphones) jack.

### 4 Input select buttons

Press to monitor the signal input to each connector.

**SDI 1 button:** to monitor the signal through the SDI 1 input connector

**SDI 2 button:** to monitor the signal through the SDI 2 input connector

**HDMI button:** to monitor the signal through the HDMI connector

**COMPOSITE button:** to monitor the signal through the COMPOSITE IN connector

### 5 Function buttons

You can turn the assigned function on or off.

The factory setting is as follows;

**F1 button:** BRIGHTNESS

**F2 button:** CONTRAST

**F3 button:** CHROMA

**F4 button:** SCAN

**F5 button:** H/V DELAY

**F6 button:** VOLUME

**F7 button:** I/P MODE

You can assign various functions in FUNCTION BUTTON SETTING of the USER CONFIG menu.

Press the button BRIGHTNESS, CONTRAST, CHROMA, VOLUME, PHASE, or APERTURE function assigned to display the adjustment screen. Press the same button again, and the adjustment screen disappears, but you can adjust the value without the setting value display.

*For details of the function assigned to the function button, see page 29.*

### 6 Menu operation buttons

Displays or sets the on-screen menu.

**Menu selection control**

When the menu is displayed, turn the control to select a menu item or setting value, and then press the control to confirm the setting.

If the menu is not displayed and the menu selection control is pressed, the characters that represent the names of the buttons light up. Also, the names of the function selected in FUNCTION BUTTON SETTING of the USER CONFIG menu appear on the screen.

Alternatively, if the menu is not displayed and the menu selection control is pressed for more than two seconds, the signal format is displayed on the screen.

#### **RETURN button**

When the menu is displayed, press the button to reset the value of an item to the previous value (except some items).

When the menu is not displayed, press the button to display the name of the function selected in FUNCTION BUTTON SETTING of the USER CONFIG menu.

#### **MENU button**

Press to display the on-screen menu.

Press again to clear the menu.

#### **7 (standby) switch and indicator**

Press to turn on the power when this unit is in standby mode. The indicator lights in green. Press the switch again to set the monitor in standby mode. The indicator goes out. When fan error occurs, the indicator blinks in green and amber alternately.

## Input Signals and Adjustable/Setting Items

Item	Input signal							
	Composite		SDI			HDMI/DVI*5		
	Color	B & W	SD	HD	3G	SD	HD	PC
CONTRAST	○	○	○	○	○	○	○	○
BRIGHTNESS*1	○	○	○	○	○	○	○	○
CHROMA	○	×	○	○	○	○	○	○
PHASE	○ (NTSC)	×	×	×	×	×	×	○
APERTURE	○	○	○	○	○	○	○	○
COLOR TEMP	○	○	○	○	○	○	○	○
COLOR SPACE	○	○	○	○	○	○	○	○
AUTO CHROMA/PHASE	○	×	×	×	×	×	×	×
ACC	○	×	×	×	×	×	×	×
CTI	○	×	×	×	×	×	×	×
V SHARPNESS	○	○	○	×	×	○	×	×
NTSC SETUP	○ (NTSC)	○ (480/60I)	×	×	×	×	×	×
SCAN	○	○	○	○	○	○	○	×
ASPECT	○	○	○	×	×	○	×	×
MARKER	○	○	○	○	○	○	○	×
BLUE ONLY	○	×	○	○	○	○	○	×
MONO	○	×	○	○	○	○	○	×
H/V DELAY*7	○	○	○	○	○	×	×	×
SHIFT	○	○	○	○	○	○	○	×
I/P MODE*2	○	○	○	○	○	○	○	×
WFM/ALM/VECTOR	○	○	○*6	○*6	○*6	○*6	○*6	○*6
RGB RANGE*3	×	×	×	×	×	○	○	○
T/C	×	×	○	○	○	×	×	×
DVI*4	×	×	×	×	×	○	○	○
SCREEN SAVER	○	○	○	○	○	○	○	○
GAMMA	○	○	○	○	○	○	○	○
FLICKER FREE	○	○	○	○	○	○	○	○
SD PIXEL MAPPING	○	○	×	×	×	×	×	×
CAMERA FOCUS	○	○	○	○	○	○	○	×
CLOSED CAPTION*5	○*8 (NTSC)	○*8 (480/60I)	○	○	×	×	×	×

○ : Adjustable/can be set  
 × : Not adjustable/cannot be set

\*1 Adjustment of SUB CONTROL is the same.

\*2 Only the interlace signal is input.

\*3 Adjustable when RGB format of HDMI signals are input.

\*4 When DVI signal is input to the HDMI IN connector using a DVI conversion cable, this can be adjusted.

\*5 When the marker display is set to ON, closed captions cannot be displayed. Caption display is also not possible when NATIVE is selected in the scan mode and a composite signal is input.

\*6 When RGB format signal is input, VECTOR cannot be displayed.

\*7 When the WFM/ALM/VECTOR display is set to ON, this does not function.

\*8 Some characters may be misplaced, cropped or missing.

# Rear Panel

## PVM-2541

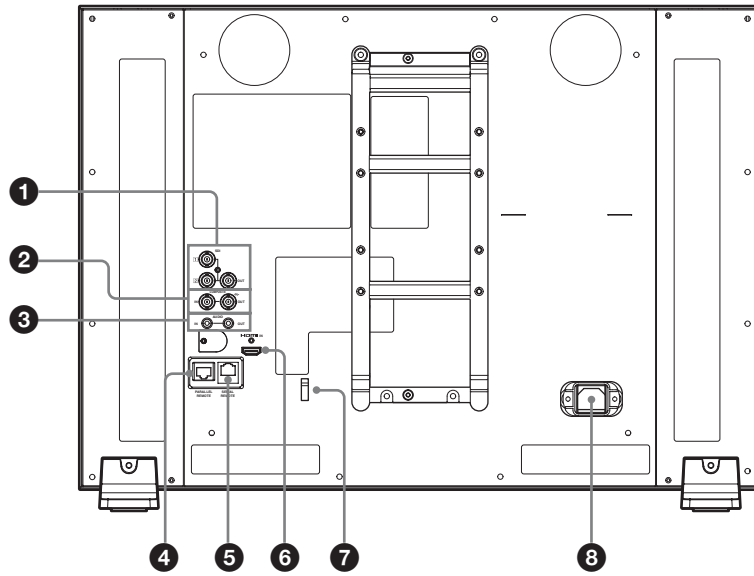

## PVM-1741

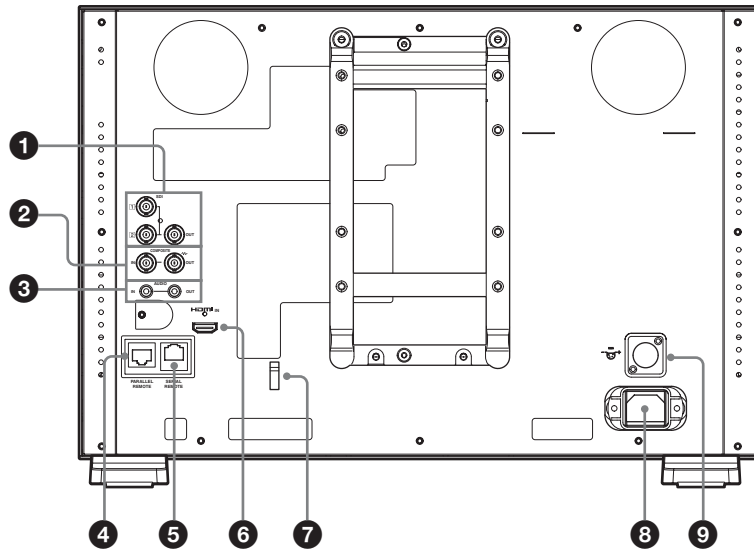

**1 SDI (3G/HD/SD) input and output connectors (BNC)**

**1 (input) connector, 2 (input) connector**

Input connector for serial digital component signals. SDI 1 and SDI 2 inputs are available.

**OUT connector**

Output connector for serial digital component signals.

**Notes**

- The signal from the OUT connector does not satisfy the ON-LINE signal specifications.
- Output is only activated when the power is on. No output in standby mode.

**2 COMPOSITE input and output connectors (BNC)**

**IN connector**

Input connector for composite video signals.

**OUT connector**

Loop-through output connector.

**Note**

When inputting a video signal with the jitters, etc. the picture may be disturbed. We recommend using the TBC (time base corrector).

**3 AUDIO input and output connectors (stereo mini jack)**

**IN connector**

Connect to the audio outputs of external equipment such as a VCR.

#### **OUT connector**

Outputs the audio signal which is selected by the input select button on the front panel.

When SDI signal is selected, either the audio signal of the channel which is selected in AUDIO SETTING of the USER CONFIG menu or the audio signal from the AUDIO IN connector is output.

#### **4 PARALLEL REMOTE connector (modular connector, 8-pin)**

Forms a parallel switch and controls the monitor externally.

*For details on the pin assignment and factory setting function assigned to each pin, see page 36.*

#### **CAUTION**

For safety, do not connect the connector for peripheral device wiring that might have excessive voltage to this port. Follow the instructions for this port.

#### **5 SERIAL REMOTE connector (RJ-45)**

Connect to the network or Sony BKM-15R/16R Monitor Control Unit by using a 10BASE-T/100BASE-TX LAN cable (shielded type, optional).

*For details, refer to the Interface Manual for Programmers (saved in the supplied CD-ROM, Japanese and English only).*

#### **CAUTION**

- For safety, do not connect the connector for peripheral device wiring that might have excessive voltage to this port. Follow the instructions for this port.
- When you connect the LAN cable of the unit to peripheral device, use a shielded-type cable to prevent malfunction due to radiation noise.
- The connection speed may be affected by the network system. This unit does not guarantee the communication speed or quality of 10BASE-T/100BASE-TX.

#### **6 HDMI input connector**

Input connector for HDMI signals.

HDMI (High-Definition Multimedia Interface) is an interface that supports both video and audio on a single digital connection, allowing you to enjoy high quality digital picture and sound. The HDMI specification supports HDCP (High-bandwidth Digital Content Protection), a copy protection technology that incorporates coding technology for digital video signals.

#### **Note**

Use HDMI compliant cable (optional) with HDMI logo.

#### **7 HDMI cable holder**

Secures the HDMI cable (Ø7 mm or less).

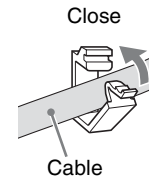

#### **8 AC IN Socket**

Connects the supplied AC power cord.

#### **9 DC IN connector (PVM-1741 only)**

Plug the DC power supply to this connector to provide power to the monitor. It runs on DC 12V.

#### **CAUTION**

Be sure to connect to a power supply of the specified voltage value.

## Removing the Monitor Stand (Pre-Attached)

To install the monitor on a rack, or use the optional SU-561 Monitor Stand, remove the bottom stand as follows.

- 1 Put the monitor on a soft cloth with the surface of the monitor downward.
- 2 Remove the three screws.

### PVM-2541

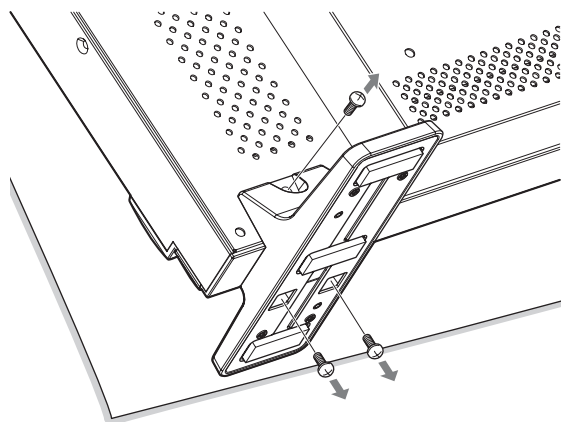

### PVM-1741

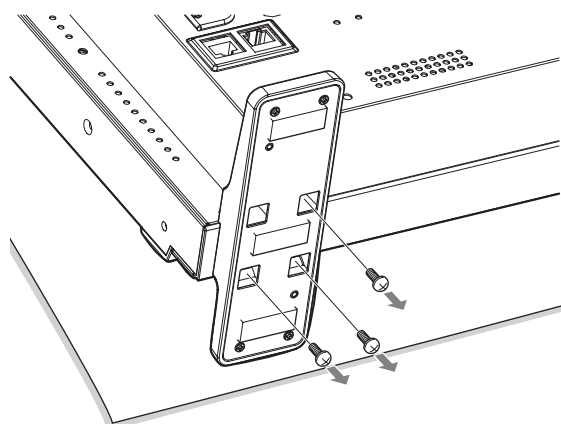

- 3 Remove the stand.

## Installing on a Rack (PVM-1741 only)

You can install PVM-1741 to the rack by using the supplied mounting bracket.

- 1 Attach the mounting bracket to the monitor with supplied screws.

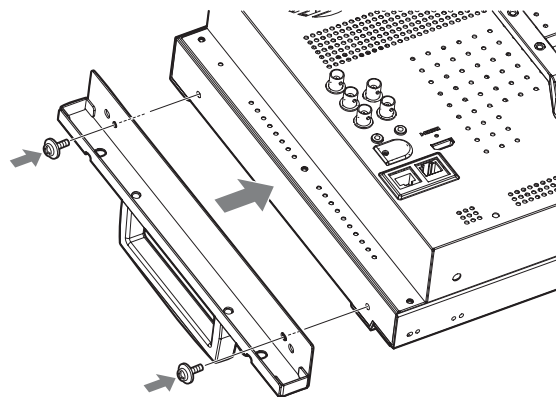

- 2 Attach the unit to the rack with four screws.

### Note

The screws are not supplied. Prepare screws according to the rack.

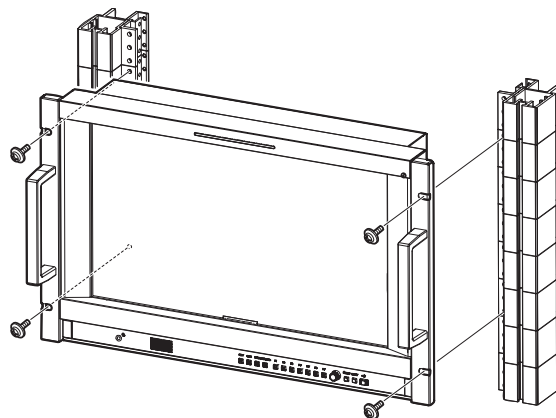

# Adjusting the Height of the Monitor (with SU-561 only)

PVM-2541 and PVM-1741 can be mounted on the optional SU-561 Monitor Stand. You can adjust the height of the monitor on three levels (for PVM-2541) or four levels (for PVM-1741) by changing the position of the stand attachment bracket and the arm attachment position.

A and B in the following list indicate the screw holes shown in the illustrations of steps 2 and 4.

## Height of the monitor

	Unit: mm (inches)			
Position of the stand attachment bracket	A	A	B	B
Arm attachment position	B	A	B	A
PVM-2541	—*1	460 (18 1/8)	469 (18 1/2)	495 (19 1/2)
PVM-1741	372 (14 3/4)	398 (15 3/4)	407 (16 1/8)	433 (17 1/8)

\*1 You cannot attach the stand in combination of these positions.

The following explains how to adjust the height of the stand. For details on mounting the monitor on SU-561, refer to the Mounting Instructions of SU-561.

### 1 With the pre-attached monitor stand

Remove the stand (see page 15).

#### With SU-561

Remove the stand and stand attachment bracket (see page 17).

- 2 Attach the stand attachment bracket to the A or B screw holes.

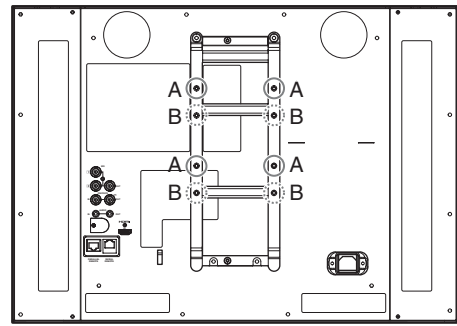

A: Screw holes for low position  
B: Screw holes for high position

- 3 Attach the stand attachment bracket with four screws.

#### When removing the pre-attached monitor stand in step 1

Use the screws supplied with SU-561.

#### When removing SU-561 in step 1

Use the screws removed in step 5 of “To remove the stand and stand attachment bracket” (see page 17).

- 4 Attach the arm.

Hang the hook of the bracket for using the A screw holes.

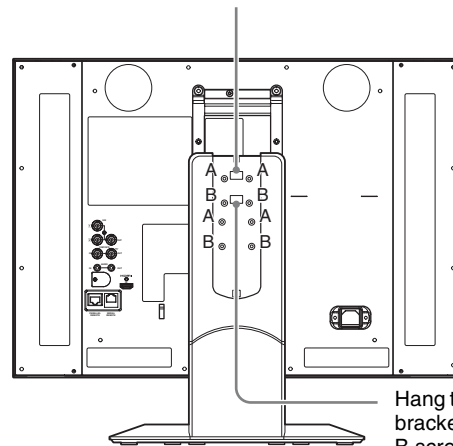

- 5 Secure the arm with four screws.

#### When removing the pre-attached monitor stand in step 1

Use the screws supplied with SU-561.

#### When removing SU-561 in step 1

Use the screws removed in step 3 of “To remove the stand and stand attachment bracket” (see page 17).



- 6 Attach the arm cover.

### To remove the stand and stand attachment bracket

- 1 Put the monitor on a soft cloth with the surface of the monitor downward.
- 2 Slide and remove the arm cover of the stand.
- 3 Remove the four screws.
- 4 Remove the arm.
- 5 Remove the four screws to remove the stand attachment bracket.

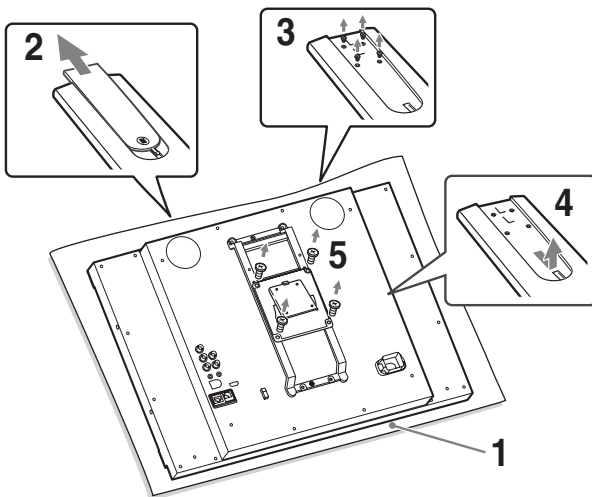

## Connecting the AC Power Cord

- 1 Plug the AC power cord into the AC IN socket on the rear panel. Then, attach the AC plug holder (supplied) to the AC power cord.

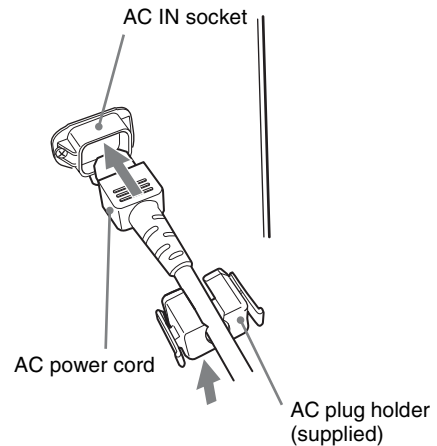

- 2 Slide the AC plug holder over the cord until it locks.

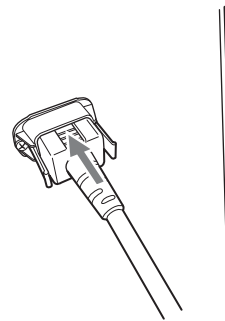

### To disconnect the AC power cord

Pull out the AC plug holder while pressing the lock levers.

# Selecting the Default Settings

When you turn on the unit for the first time after purchasing it, select the area where you intend to use this unit from among the options.

## The default setting values for each area

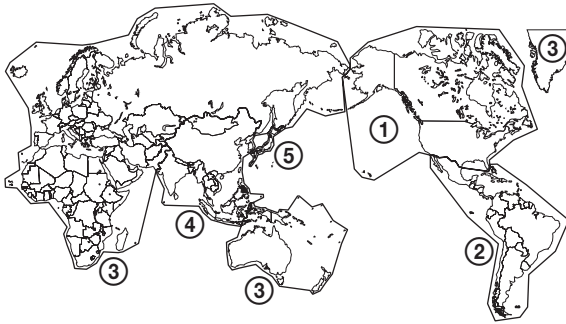

	COLOR TEMP	NTSC SETUP	COLOR SPACE	FLICKER FREE
<b>① NORTH AMERICA</b>	D65	7.5	ITU-709	OFF
<b>② LATIN AMERICA</b>				
PAL&PAL-N AREA				
ARGENTINA	D65	0	ITU-709	ON
PARAGUAY	D65	0	ITU-709	ON
URUGUAY	D65	0	ITU-709	ON
NTSC&PAL-M AREA				
OTHER AREA	D65	7.5	ITU-709	OFF
<b>③ AFRICA AUSTRALASIA EUROPE MIDDLE-EAST</b>	D65	0	ITU-709	ON
<b>④ ASIA EXCEPT JAPAN</b>				
NTSC AREA	D65	7.5	ITU-709	OFF
PAL AREA	D65	0	ITU-709	ON
<b>⑤ JAPAN</b>	D93	0	ITU-709	OFF

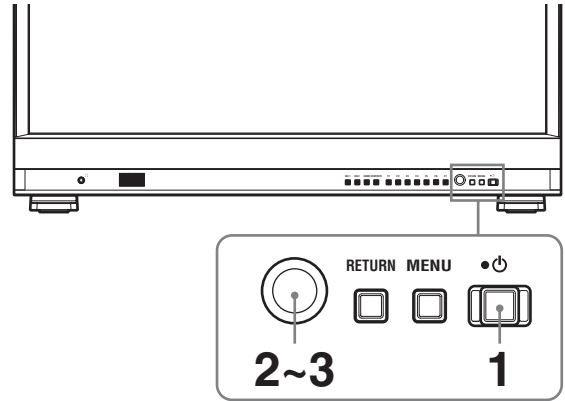

- 1 Press the ⏻ (standby) switch.

The unit is turned on and the SELECT SETTING screen appears.

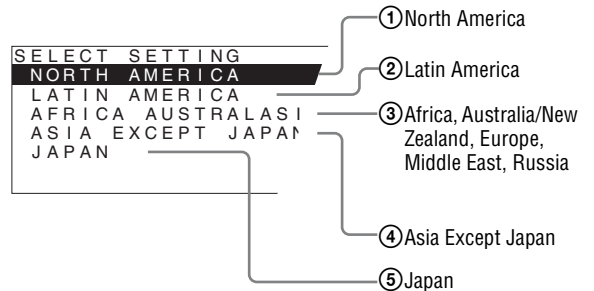

- 2 Turn the menu selection control to select the area where you intend to use the unit and press the menu selection control.

### If you select either ①, ③ or ⑤

The confirmation screen is displayed. Confirm the selected area. When the setting is wrong, press the RETURN button to return to the previous screen.

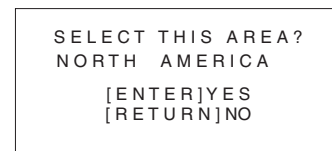

### If you select either ② or ④

One of the following screens appears. Turn the menu selection control to narrow the area further and then press the menu selection control. The confirmation screen is displayed. Confirm the selected area.

If the setting is wrong, press the RETURN button to return to the previous screen.

② If LATIN AMERICA is selected:

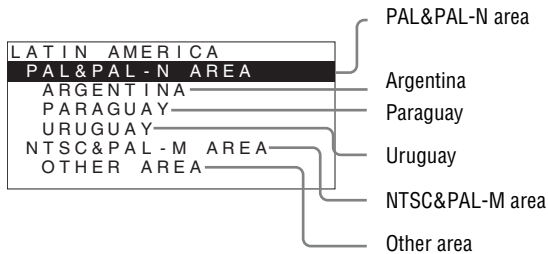

④ If ASIA EXCEPT JAPAN is selected:

Customers who will use this unit in the shaded areas shown in the map below should select NTSC AREA. Other customers should select PAL AREA.

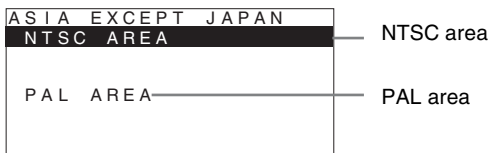
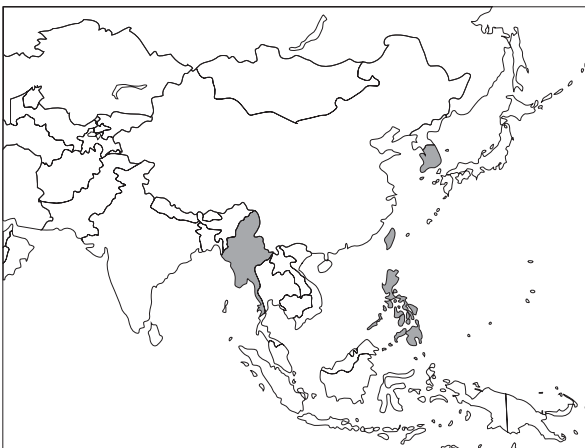

3 Press the menu selection control.

The SELECT SETTING screen disappears and the menu item settings suitable for the selected area are applied.

**Note**

When you have selected the wrong area, set the following items using the menu.

- COLOR TEMP (on page 23)
- NTSC SETUP (on page 25)
- COLOR SPACE (on page 24)
- FLICKER FREE (on page 26)

See “The default setting values for each area” (page 18) on the setting value.

# Selecting the Menu Language

You can select one of seven languages (English, French, German, Spanish, Italian, Japanese, Chinese) for displaying the menu and other on-screen displays. “ENGLISH (English)” is selected in the default setting. The current settings are displayed in place of the ■ marks on the illustrations of the menu screen.

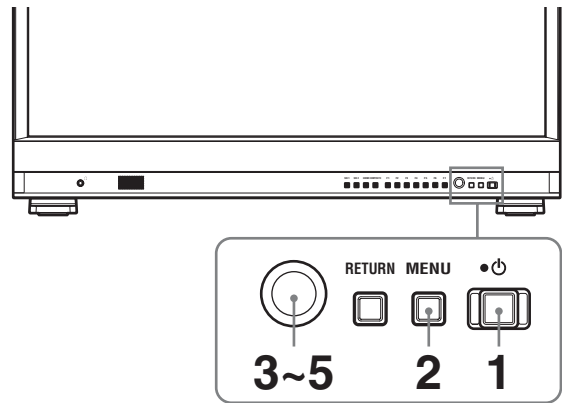

- 1 Turn on the unit.
- 2 Press the MENU button.

The menu appears. The menu presently selected is shown in yellow.

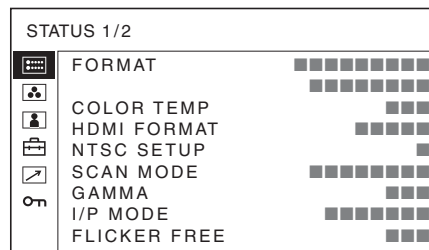

- 3 Turn the menu selection control to select SYSTEM SETTING of the USER CONFIG (user configuration) menu, then press the menu selection control.

The setting items (icons) in the selected menu are displayed in yellow.

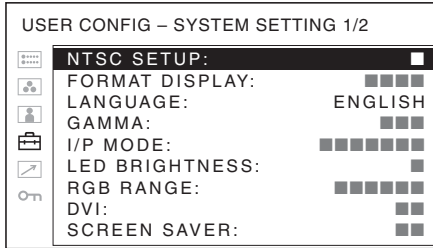

- 4 Turn the menu selection control to select “LANGUAGE”, then press the menu selection control.

The selected item is displayed in yellow.

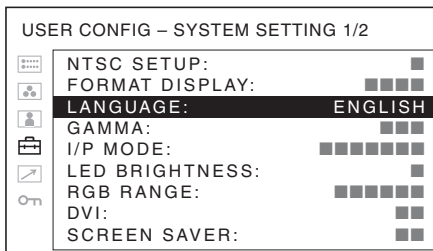

- 5 Turn the menu selection control to select a language, then press the menu selection control.

The menu changes to the selected language.

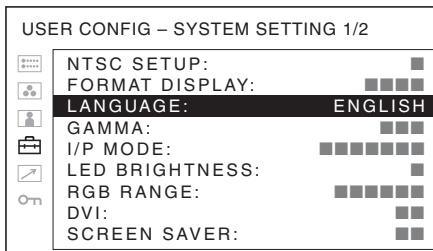

### To clear the menu

Press the MENU button.

The menu disappears automatically if a button is not pressed for one minute.

## Using the Menu

The unit is equipped with an on-screen menu for making various adjustments and settings such as picture control, input setting, set setting change, etc. You can also change the menu language displayed in the on-screen menu.

To change the menu language, see “Selecting the Menu Language” on page 19.

The current settings are displayed in place of the ■ marks on the illustrations of the menu screen.

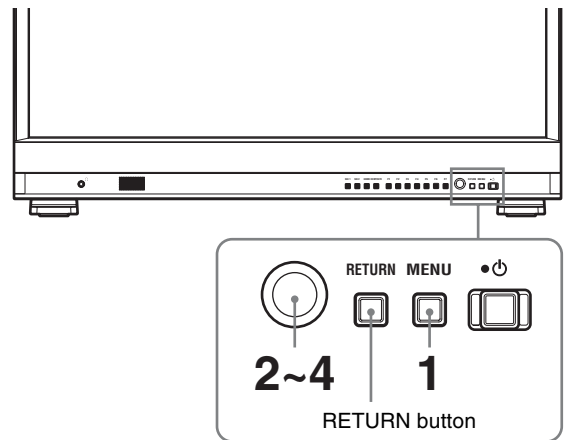

- 1 Press the MENU button.

The menu appears.

The menu presently selected is shown in yellow.

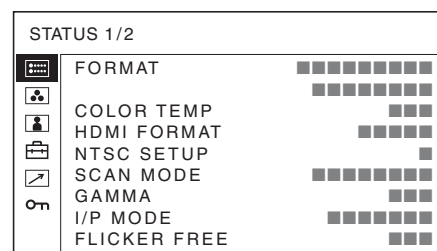

- 2 Turn the menu selection control to select a menu, then press the menu selection control.

The menu icon presently selected is shown in yellow and setting items are displayed.

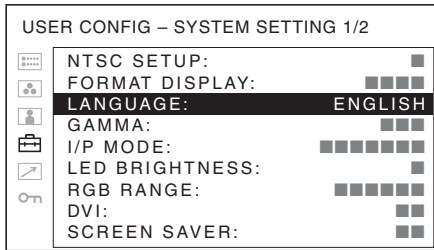

The menu disappears automatically if a button is not pressed for one minute.

## About the memory of the settings

The settings are automatically stored in the monitor memory.

### 3 Select an item.

Turn the menu selection control to select the item, then press the menu selection control. The item to be changed is displayed in yellow. If the menu consists of multiple pages, turn the menu selection control to go to the desired menu page.

### 4 Make the setting or adjustment on an item.

#### When changing the adjustment level:

To increase the number, turn the menu selection control right.

To decrease the number, turn the menu selection control left.

Press the menu selection control to confirm the number, then restore the original screen.

#### When changing the setting:

Turn the menu selection control to change the setting, then press the menu selection control to confirm the setting.

#### When returning the adjustment or setting to the previous value:

Press the RETURN button before pressing the menu selection control.

#### Notes

- An item displayed in black cannot be accessed. You can access the item if it is displayed in white.
- If the key inhibit has been turned on, all items are displayed in black. To change any of the items, turn the key inhibit to OFF first.

*For details on the key inhibit, see page 34.*

## To return the display to the previous screen

Press the RETURN button.

## To clear the menu

Press the MENU button.

# Adjustment Using the Menus

## Items

The screen menu of this monitor consists of the following items.

### **STATUS** (the items indicate the current settings.)

#### For the video input

FORMAT  
COLOR TEMP  
HDMI FORMAT  
NTSC SETUP  
SCAN MODE  
GAMMA  
I/P MODE  
FLICKER FREE  
Model name and serial number

#### For the DVI input signal from PC

FORMAT  
fH  
fV  
COLOR TEMP  
HDMI FORMAT  
GAMMA  
FLICKER FREE  
Model name and serial number

### **COLOR TEMP/SPACE**

COLOR TEMP  
MANUAL ADJUSTMENT  
COLOR SPACE

### **USER CONTROL**

SUB CONTROL  
AUTO CHROMA/PHASE  
PICTURE CONTROL  
INPUT SETTING

### **USER CONFIG**

SYSTEM SETTING  
NTSC SETUP  
FORMAT DISPLAY  
LANGUAGE  
GAMMA  
I/P MODE  
LED BRIGHTNESS

RGB RANGE  
DVI  
SCREEN SAVER  
FLICKER FREE  
SD PIXEL MAPPING  
MARKER SETTING  
MARKER ENABLE  
MARKER SELECT  
CENTER MARKER  
SAFETY AREA  
MARKER LEVEL  
MARKER MAT  
T/C DISPLAY SETTING  
T/C  
FORMAT  
POSITION  
TRANSPARENCY  
WFM/ALM/VECTOR (waveform monitor, audio level meter, and vectorscope) SETTING  
DISPLAY  
WFM/ALM/VECTOR  
POSITION  
COLOR  
INTENSITY  
ZOOM  
LINE SELECT  
LINE POSITION  
TARGET  
FOCUS SETTING  
FOCUS MODE  
COLOR  
FREQUENCY  
RANGE  
GAIN  
FUNCTION BUTTON SETTING  
F1 BUTTON  
F2 BUTTON  
F3 BUTTON  
F4 BUTTON  
F5 BUTTON  
F6 BUTTON  
F7 BUTTON  
CLOSED CAPTION SETTING  
CLOSED CAP.  
TYPE  
708  
608  
CAPTION LEVEL  
AUDIO SETTING  
SDI AUDIO SETTING

### **REMOTE**

PARALLEL REMOTE  
SERIAL REMOTE

### **KEY INHIBIT**

KEY INHIBIT

## Adjusting and Changing the Settings

### STATUS menu

The STATUS menu is used to display the current status of the unit. The following items are displayed:

#### For the video input

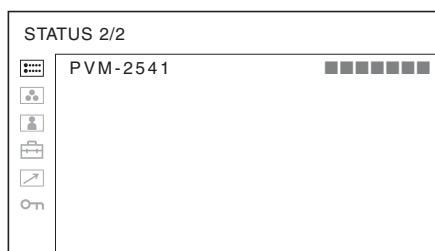
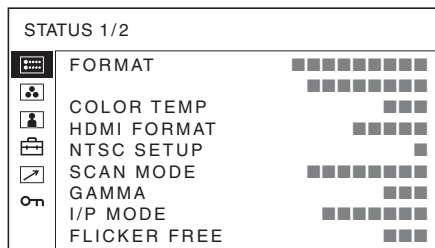

- Signal format
- Color temperature
- HDMI format
- NTSC setup
- Scan mode
- Gamma
- I/P mode
- Flicker free
- Model name and serial number

#### For the DVI input signal from PC

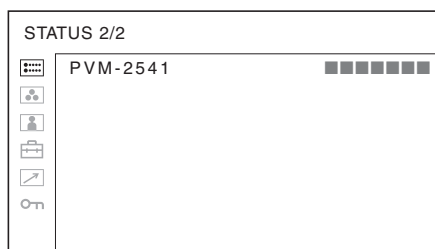
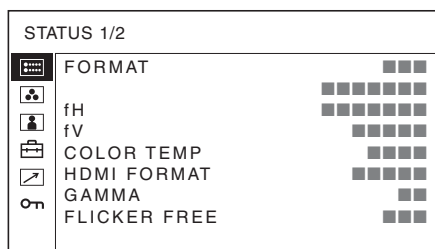

- Signal format
- fH
- fV

- Color temperature
- HDMI format
- Gamma
- Flicker free
- Model name and serial number

### COLOR TEMP/SPACE menu

The COLOR TEMP/SPACE menu is used for adjusting the picture white balance or color space. You need to use the measurement instrument to adjust the white balance.

Recommended: Konica Minolta color analyzer CA-210/CA-310

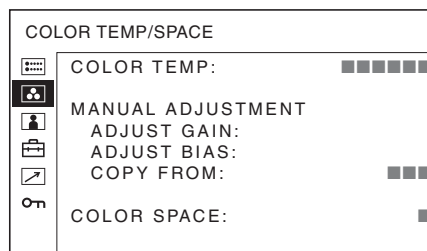

Submenu	Setting
COLOR TEMP	Selects the color temperature from among D65, D93 and USER setting.

#### Note

If you measure the color temperatures of different display types, such as CRT, LCD, or OLED, by using a common (or general) color analyzer that is based on CIE 1931, and adjust the xy chromaticity to the same value, the appearance may be different because of optical spectrum differences.

To compensate for this difference, the D65 and D93 settings of the monitor are adjusted by an offset\*.

(Serial No. 3100001 or later)  
 \* The offset value applied (x-0.006, y-0.011) is based on the Judd's function to the CIE 1931 (x, y) value.

Submenu	Setting
MANUAL ADJUSTMENT	<p>If you set the COLOR TEMP to USER setting, the item displayed is changed from black to white, which means you can adjust the color temperature.</p> <p>The set values are memorized.</p> <ul style="list-style-type: none"> <li>• <b>ADJUST GAIN:</b> Adjusts the color balance (GAIN).</li> <li>• <b>ADJUST BIAS:</b> Adjusts the color balance (BIAS).</li> <li>• <b>COPY FROM:</b> If you select D65 or D93, the white balance data for the selected color temperature will be copied in the USER setting.</li> </ul>
COLOR SPACE	<p>Selects the color space from among EBU, SMPTE-C, ITU-709 and OFF. OFF sets the color space to the original color reproduction of the panel.</p>

### USER CONTROL menu

The USER CONTROL menu is used for adjusting the picture.

Items that cannot be adjusted depending on the input signal are displayed in black.

*For details of input signal and adjustable / setting items, see page 12.*

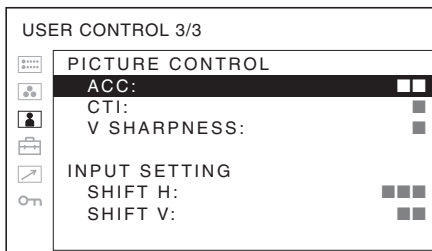
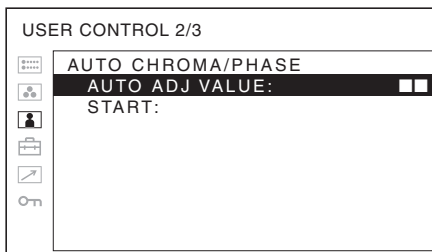
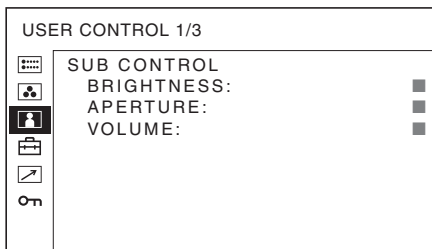

Submenu	Setting
SUB CONTROL	<p>Adjusts finely the adjustment range of the function buttons which BRIGHTNESS is assigned.</p> <ul style="list-style-type: none"> <li>• <b>BRIGHTNESS:</b> Adjusts the picture brightness.</li> <li>• <b>APERTURE:</b> Adjusts the picture sharpness. The higher the setting, the sharper the picture. The lower the setting, the softer the picture. APERTURE does not work when the camera focus function is activated.</li> <li>• <b>VOLUME:</b> Adjusts the volume.</li> </ul>
AUTO CHROMA/PHASE	<p>Adjusts color intensity (CHROMA) and tones (PHASE).</p> <ul style="list-style-type: none"> <li>• <b>AUTO ADJ VALUE:</b> Selects ON or OFF of the auto adjustment. When you set to OFF, this parameter is reset to the factory setting. When you set to ON, the automatically adjusted value is enabled.</li> <li>• <b>START:</b> The auto adjustment starts when you display the color bar signals (Full/SMPTE/EIA) on the screen and press the menu selection control. After adjusting the color intensity, press the MENU button to clear the adjustment screen. After the adjustment is done correctly, the AUTO ADJ VALUE is automatically set to ON.</li> </ul>
PICTURE CONTROL	<p>Adjusts the picture.</p> <ul style="list-style-type: none"> <li>• <b>ACC (Auto Color Control):</b> Sets ACC circuit on or off. To check the fine adjustment, select OFF. Normally select ON.</li> <li>• <b>CTI (Chroma Transient Improvement):</b> When a low color resolution signal is input, a crisp image can be displayed. When the setting is higher, the picture becomes even more crisp.</li> <li>• <b>V SHARPNESS:</b> A crisp image can be displayed. When the setting is higher, the picture becomes even more crisp.</li> </ul>



Submenu	Setting
INPUT SETTING	<ul style="list-style-type: none"> <li>• <b>SHIFT H</b>: Adjusts the position of the picture. As the setting increases, the picture moves to the right, and as the setting decreases, the picture moves to the left.</li> <li>• <b>SHIFT V</b>: Adjusts the position of the picture. As the setting increases, the picture moves up, and as the setting decreases, the picture moves down.</li> </ul>

## USER CONFIG menu

The USER CONFIG menu is used for setting the system, marker, T/C display, WFM/ALM/VECTOR, focus, function button, closed caption, and audio.

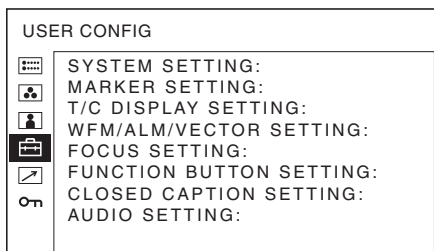

## SYSTEM SETTING

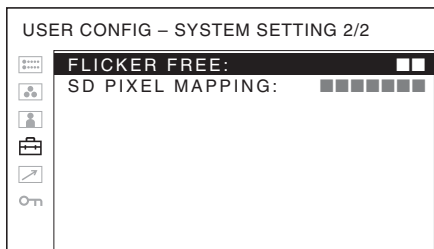
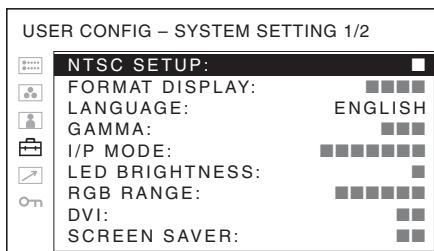

Submenu	Setting
NTSC SETUP	<p>Selects the NTSC setup level from two modes.</p> <p>The 7.5 setup level is used mainly in North America. The 0 setup level is used mainly in Japan.</p>

Submenu	Setting
FORMAT DISPLAY	<p>Selects the display mode of the signal format and scan mode.</p> <ul style="list-style-type: none"> <li>• <b>OFF</b>: The display is hidden.</li> <li>• <b>AUTO</b>: The format and scan mode are displayed for about five seconds when the input of the signal starts.</li> </ul>
LANGUAGE	<p>Selects the menu or message language from among seven languages.</p> <ul style="list-style-type: none"> <li>• <b>ENGLISH</b>: English</li> <li>• <b>FRANÇAIS</b>: French</li> <li>• <b>DEUTSCH</b>: German</li> <li>• <b>ESPAÑOL</b>: Spanish</li> <li>• <b>ITALIANO</b>: Italian</li> <li>• 日本語 : Japanese</li> <li>• 中文 : Chinese</li> </ul>
GAMMA	<p>Select the appropriate gamma mode from among 2.4, 2.2, and CRT.</p> <p>If you select the CRT mode while either ITU-709 or OFF is selected in COLOR SPACE, gamma settings are adjusted to those in the gamma 2.4 mode.</p> <p>The factory setting is gamma 2.4 that is specified by ITU-R BT.1886. By using this gamma the dark areas may appear darker than that of a CRT or LCD. If you want to set the gamma to that of a CRT or LCD, select CRT or 2.2. Also if the blacks appear to be crushed, adjust BRIGHTNESS to show more detail.</p>

Submenu	Setting
I/P MODE (picture delay minimum)	<p>Selects to set the delay by the picture processing to the minimum level when the interlace signal is input.</p> <ul style="list-style-type: none"> <li>• <b>INTER-FIELD*</b>: Mode for giving precedence to the picture quality. Performs interpolation depending on the movement of the images between the fields. It takes longer than the other setting modes to process the picture.</li> <li>• <b>FIELD MERGE</b>: The processing time is shorter. Combines the lines in the odd fields and even fields alternately regardless of the movement of images. Suitable for viewing still images.</li> <li>• <b>LINE DOUBLER</b>: The processing time is shorter. Performs interpolation by repeating each line in the data receiving sequence regardless of the field. As the line flicker is displayed in this mode, it is available for checking the line flicker of the telop work and so on.</li> <li>• <b>INTRA-FIELD</b>: INTRA-FIELD is only available for 1920 × 1080 SDI signal input. Mode to provide naturally reproduced image and quick picture processing. Performs interpolation within the fields. Suitable for 1920 × 1080 SDI signal input.</li> </ul> <p>* When DISPLAY in WFM/ALM/VECTOR SETTING is activated, INTER-FIELD cannot be selected.</p>
LED BRIGHTNESS	<p>Selects the brightness of the LED of the buttons.</p> <ul style="list-style-type: none"> <li>• <b>HIGH</b>: The LED becomes brighter.</li> <li>• <b>LOW</b>: The LED becomes darker.</li> </ul>
RGB RANGE	<p>Sets the black level and white level for the RGB format of HDMI input.</p> <ul style="list-style-type: none"> <li>• <b>FULL</b>: 0 (black level) to 255 (white level)</li> <li>• <b>LIMITED</b>: 16 (black level) to 235 (white level)</li> </ul>
DVI	<p>Selects a format for DVI input signal.</p> <ul style="list-style-type: none"> <li>• <b>PC</b>: For RGB signal format</li> <li>• <b>VIDEO</b>: For YPBPR signal format</li> </ul>

Submenu	Setting
SCREEN SAVER	<p>Sets the screen saver function on or off.</p> <ul style="list-style-type: none"> <li>• <b>ON</b>: If a still image is displayed for more than 10 minutes, the brightness of the screen is automatically decreased to reduce burn-in. The screen returns to normal brightness when you input an image to the unit or operate the buttons on the front panel of the unit. While the screen saver is activated, the LED of the selected input select button flashes. (To decrease the brightness of the LED, see "LED BRIGHTNESS" on page 26.) This is the factory setting.</li> <li>• <b>OFF</b>: The screen saver function is deactivated.</li> </ul>
FLICKER FREE	<p>Set this to ON to enable view images without flicker. The ON setting will eliminate flicker, but quick-moving images may exhibit contours or an afterimage. For details, see "About the function assigned to the function button" (page 30).</p>
SD PIXEL MAPPING	<p>Selects SD picture size (pixels) according to the input signal format from the COMPOSITE IN connector.</p> <p><b>When picture signals in the size of 720 × 576 (50i) (or 720 × 487 (60i)) are input</b>  Select 720 × 576 (or 720 × 487). This is the default setting.  When 702 × 576 (or 712 × 483) is selected, all sides of the input picture are cut off by several pixels.</p> <p><b>When picture signals in the size of 702 × 576 (50i) (or 712 × 483 (60i)) or equivalent are input</b>  Select 702 × 576 (or 712 × 483).  When 720 × 576 (or 720 × 487) is selected, a black border (of several pixels wide) appears around the input picture.</p>

## MARKER SETTING

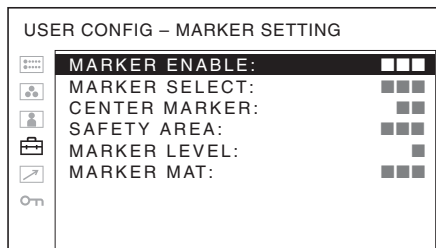

Submenu	Setting
MARKER ENABLE	Selects ON to display the marker and OFF not to display.
	<p><b>Note</b></p> <p>When NATIVE is selected in the SCAN setting, the marker is not displayed. To display the marker, select a setting other than NATIVE.</p>
MARKER SELECT	<p>Selects the aspect ratio according to the film, when the frame of the film is displayed on the screen.</p> <p><b>When 16:9 aspect ratio is selected with the button which the aspect function is assigned</b> You can select from among 4:3, 15:9, 14:9, 13:9, 1.85:1, 2.35:1, 1.85:1 &amp; 4:3 and OFF.</p> <p><b>When 4:3 aspect ratio is selected with the button which the aspect function is assigned</b> You can select 16:9 or OFF.</p>
CENTER MARKER	Selects ON to display the center mark of the picture and OFF not to display.
SAFETY AREA	Selects the safe area size for the aspect ratio determined by the button to which the aspect function is assigned. You can select from OFF, 80%, 85%, 88%, 90% and 93%. When the marker is displayed, the safe area for the marker is displayed.
MARKER LEVEL	Sets the luminance to display the MARKER SELECT, CENTER MARKER and SAFETY AREA. You can select between 1 and 2. When the setting is low, the marker appears dark.
MARKER MAT	<p>Selects whether you put mat on the outside of the marker display.</p> <ul style="list-style-type: none"> <li>• <b>OFF</b>: No mat is put.</li> <li>• <b>HALF</b>: Gray mat is put.</li> </ul>

## T/C (time code) DISPLAY SETTING

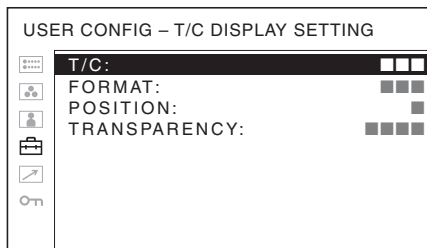

Submenu	Setting
T/C	Selects ON to display the time code display and OFF not to display.
FORMAT	<p>Sets the time code format.</p> <ul style="list-style-type: none"> <li>• <b>VITC</b>: To display the time code in VITC format.</li> <li>• <b>LTC</b>: To display the time code in LTC format.</li> </ul>
POSITION	<p>Sets the position of the time code display. You can select between 1 and 2.</p> <ul style="list-style-type: none"> <li>• <b>1</b>: Top</li> <li>• <b>2</b>: Bottom</li> </ul>
TRANSPARENCY	<p>Selects BLACK or HALF (transparent) for the background of T/C display.</p> <ul style="list-style-type: none"> <li>• <b>BLACK</b>: The background becomes black. Displayed image is hidden behind the background.</li> <li>• <b>HALF</b>: The background becomes transparent. Displayed image appears under the T/C display.</li> </ul>

## WFM/ALM/VECTOR (waveform monitor, audio level meter, and vectorscope) SETTING

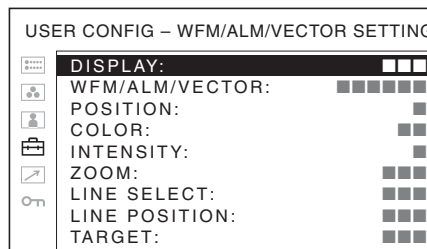

Submenu	Setting
DISPLAY	Select ON to display the WFM (waveform monitor), ALM (audio level meter), or VECTOR (Vectorscope); or OFF not to display.

Submenu	Setting
WFM/ALM/ VECTOR	<p>Sets the display settings for WFM/ALM/ vectorcope.</p> <ul style="list-style-type: none"> <li>• <b>WFM:</b> Displays the wave form monitor.</li> <li>• <b>ALM:</b> Displays the audio level meter.</li> <li>• <b>VECTOR:</b> Displays the vectorscope.</li> </ul> <p>When WFM is selected, the waveform and audio level are displayed. When ALM is selected, the audio level is displayed in eight channels. When VECTOR is selected, the color component of the image signal and the audio levels are displayed.</p> <p>When SDI signal is input, the audio levels for channels selected in SDI AUDIO SETTING are displayed.</p> <p>Each display type is illustrated below. (The waveform percentage and audio level units/values do not appear on the display.)</p>

When WFM is selected

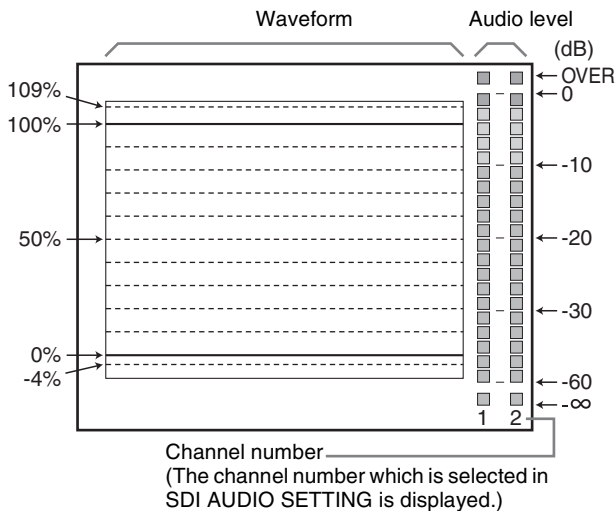

When ALM is selected

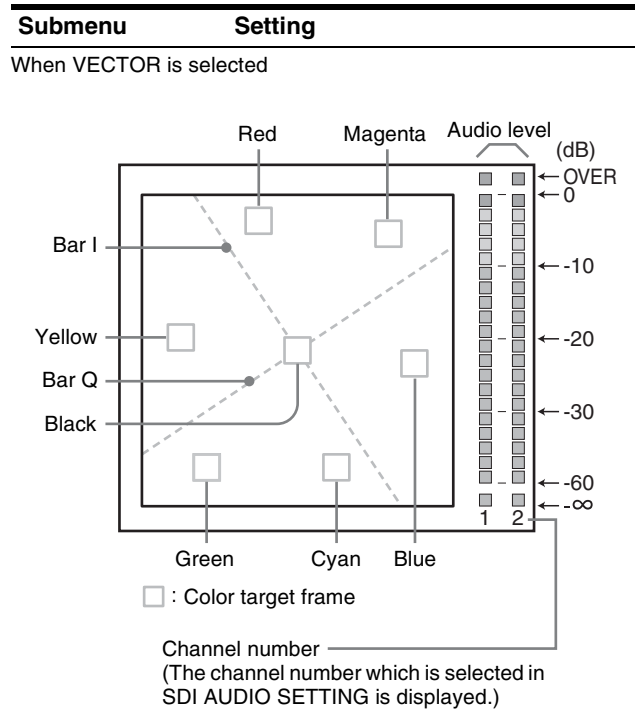
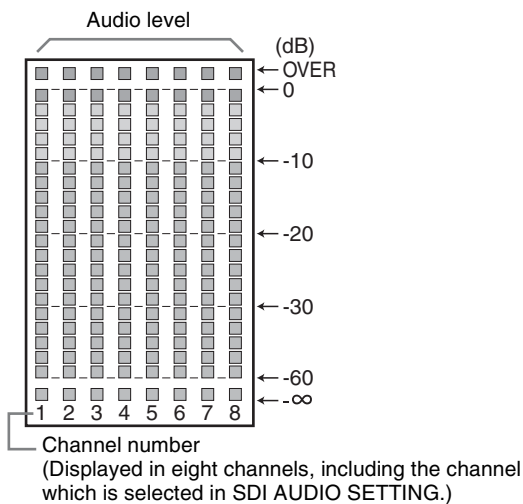

POSITION	<p>Sets the position of the WFM/ALM/ VECTOR display. You can select from among 1 to 4.</p> <ul style="list-style-type: none"> <li>• 1: Bottom left</li> <li>• 2: Bottom right</li> <li>• 3: Top right</li> <li>• 4: Top left</li> </ul>
COLOR	<p>Selects the displayed line color from white (W), red (R), green (G), blue (B) and yellow (YL), when WFM is selected.</p>
INTENSITY	<p>Sets the brightness of the waveform, etc. The larger the value, the brighter the waveform.</p>
ZOOM	<p>When ON is set, 0-20 IRE areas will be zoomed when WFM is selected, or black areas will be zoomed when VECTOR is selected.</p>
LINE SELECT	<p>Select ON to display the wave form of the line assigned in LINE POSITION below, when WFM is selected.</p>
LINE POSITION	<p>Sets the line position when WFM is selected. When the numerical value is increased, the line will move down; when decreased, the line will move up.</p>
TARGET	<p>Select 75 or 100. Switches the vectorscope target between 75% and 100%.</p>

## FOCUS SETTING

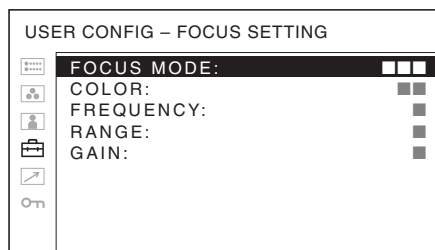

Submenu	Setting
FOCUS MODE	Switches the focus mode. <ul style="list-style-type: none"> <li>• <b>STD</b>: An image with sharpened edges is displayed.</li> <li>• <b>COLOR</b>: Displays the intensified areas of images with color selected in COLOR below.</li> <li>• <b>OFF</b>: FOCUS MODE is deactivated.</li> </ul>
COLOR	Selects the displayed intensified color from white (W), red (R), green (G), blue (B), and yellow (YL).
FREQUENCY	Sets the center frequency of the edge sharpening signal. You can select from L, M, MH, H.
RANGE	Sets the amount by which the level of edge sharpening may vary. You can set from 1 to 3.
GAIN	Sets the level of edge sharpening. You can select from 0 to 100.

## FUNCTION BUTTON SETTING

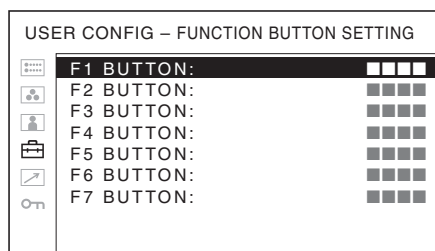

Submenu	Setting
F1 BUTTON to F7 BUTTON	Assigns the function to the function buttons of the front panel and turns the function on or off. You can assign the function from among SCAN, ASPECT, BLUE ONLY, MONO, MARKER, I/P MODE, etc. <b>Factory setting</b> <ul style="list-style-type: none"> <li>• <b>F1 button</b>: BRIGHTNESS</li> <li>• <b>F2 button</b>: CONTRAST</li> <li>• <b>F3 button</b>: CHROMA</li> <li>• <b>F4 button</b>: SCAN</li> <li>• <b>F5 button</b>: H/V DELAY</li> <li>• <b>F6 button</b>: VOLUME</li> <li>• <b>F7 button</b>: I/P MODE</li> </ul>

## About the function assigned to the function button

### SCAN

Press the button to change the scan size of the picture. With every press of the button, the picture switches in the sequence NORMAL scan → OVER scan → NATIVE. (see “Scan mode image” on page 30).

### ASPECT

Press the button to set the aspect ratio of the picture, 4:3 or 16:9.

### BLUE ONLY

Press the button to eliminate the red and green signals. Only blue signal is displayed as an apparent monochrome picture on the screen. This facilitates “chroma” and “phase” adjustments and observation of signal noise.

### MONO

Press the button to display a monochrome picture. When the buttons is pressed again, the monitor switches automatically to color mode.

### MARKER

Press the button to display the marker. Set the aspect marker in the MARKER SETTING menu (see page 27).

### H/V DELAY

Press the button to observe the horizontal and vertical sync signals at the same time.

### CLOSED CAP.

Press the button to display the closed caption. Set the closed caption setting in the CLOSED CAPTION SETTING menu (see page 31).

### WFM/ALM/VS (WFM/ALM/VECTOR)

Press the button to display the WFM/ALM/vectorscope display. Set the WFM/ALM/vectorscope display setting in the WFM/ALM/VECTOR SETTING menu (see page 27).

When LINE SELECT is set to ON and WFM is selected, each time you press the button, the settings change in the sequence WFM display activated → Line position setting → WFM display deactivated. Turn the menu selection control to move the line, when the line position is selected.

When LINE SELECT is set to OFF, the WFM display switches between activated and deactivated.

### ZOOM

Press the button to zoom in the WFM/ALM/vectorscope display. Set the ZOOM setting in the WFM/ALM/VECTOR SETTING menu (see page 28).

## BRIGHTNESS

Press the button to display the adjustment screen and adjust the picture brightness. Press again to hide the adjustment screen. However, the picture brightness remains adjustable. Turn the menu selection control right to increase the brightness and turn left to decrease it.

## CONTRAST

Press the button to display the adjustment screen and adjust the picture contrast. Press again to hide the adjustment screen. However, the picture contrast remains adjustable. Turn the menu selection control right to increase the contrast and turn left to decrease it.

## CHROMA

Press the button to display the adjustment screen and adjust the color intensity. Press again to hide the adjustment screen. However, the color intensity remains adjustable. Turn the menu selection control right to increase the intensity and turn left to decrease it.

## VOLUME

Press the button to display the adjustment screen and adjust the volume. Press again to hide the adjustment screen. However, the volume remains adjustable. Turn the menu selection control right to increase the volume and turn left to decrease it.

## I/P MODE

Press the button to set the delay by the picture processing to the minimum level when interlace signal is input. The mode switches in the sequence INTER-FIELD → FIELD MERGE → LINE DOUBLER → INTRA-FIELD with every press of the button (see I/P MODE on page 26).

## PHASE

Press the button to display the adjustment screen and adjust the color tones. Press again to hide the adjustment screen. However, the color tones remain adjustable. Turn the menu selection control right to increase the green tone and turn left to increase the purple tone.

## APERTURE

Press the button to display the adjustment screen and adjust the picture sharpness. Press again to hide the adjustment screen. However, the picture sharpness remains adjustable. Turn the menu selection control right to make the picture sharper and turn left to make the picture softer.

## FOCUS

Press the button to confirm the camera focus. An image with sharpened edges is displayed.

## T/C

Press the button to display the time code display. Adjust the settings for the time code display in T/C DISPLAY SETTING (see page 27).

## FLICKER FREE

Press the button to change the FLICKER FREE setting.

An OLED panel can provide superior video responsiveness and scan driving, reproducing images with little contouring or afterimaging. However, scan driving can cause flicker when input signals have a low vertical frequency (24P/PsF, 50I, etc.). Set FLICKER FREE to ON to greatly reduce this phenomenon. With this mode set to ON, quick-moving images may exhibit contours or an afterimage.

## Scan mode image

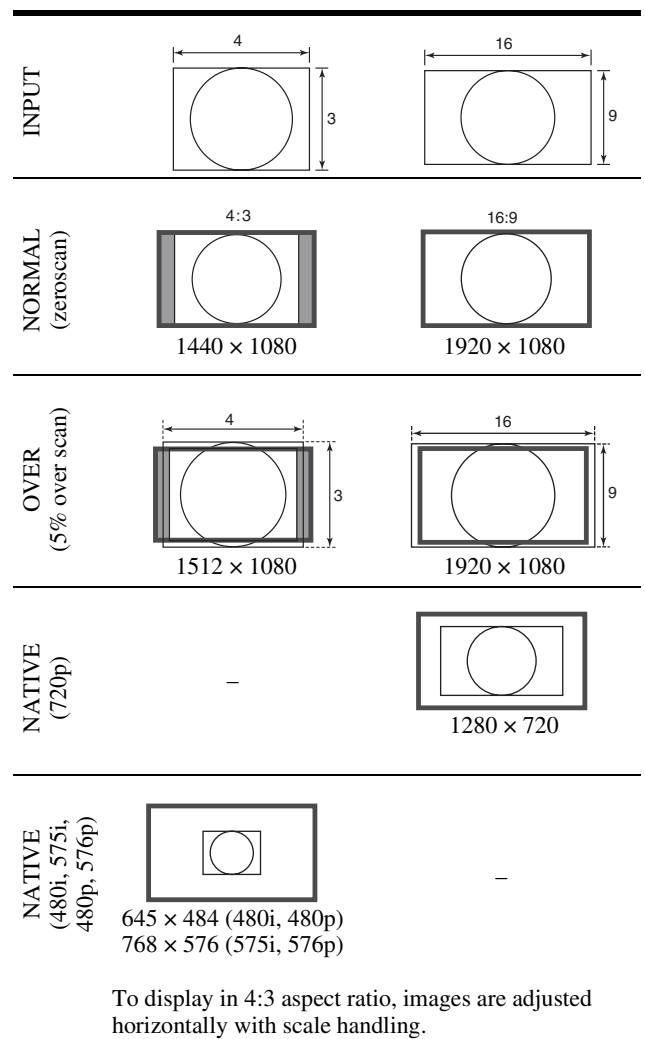

## CLOSED CAPTION SETTING

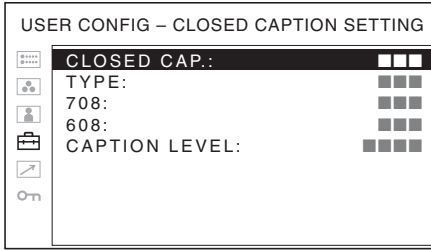

Submenu	Setting
CLOSED CAP.	Select ON to display closed caption and OFF not to display.
TYPE	<p>Sets the closed caption display type.</p> <ul style="list-style-type: none"> <li>• <b>AUTO1</b>: Select this to display automatically 608(VBI)*<sup>3</sup> when SD-SDI signal is input, or to display automatically 708*<sup>1</sup> when HD-SDI signal is input.</li> <li>• <b>AUTO2</b>: Select this to display automatically 608(VBI)*<sup>3</sup> when SD-SDI signal is input, or to display automatically 608(708)*<sup>2</sup> when HD-SDI signal is input.</li> <li>• <b>708</b>: Select this to display 708*<sup>1</sup> when HD-SDI signal is input.</li> <li>• <b>608(708)</b>: Select this to display 608(708)*<sup>2</sup> when HD-SDI signal is input.</li> <li>• <b>608(VBI)</b>: Select this to display 608(VBI)*<sup>3</sup> when SD-SDI signal is input.</li> </ul> <p>*1 708 is a closed caption signal conforming to the EIA/CEA-708 standard.</p> <p>*2 608(708) is a closed caption signal conforming to the EIA/CEA-608 standard, and which is transmitted as EIA/CEA-708 standard.</p> <p>*3 608(VBI) is a closed caption signal conforming to the EIA/CEA-608 standards, and which is transmitted as Line 21.</p>
708	Sets the closed caption type for 708. Select from SERVICE1 to SERVICE6.
608	Sets the closed caption type for 608(708) and 608(VBI). Select from CC1, CC2, CC3, CC4, TEXT1, TEXT2, TEXT3 and TEXT4.

Submenu	Setting
CAPTION LEVEL	Sets the luminance of the displayed characters. Select LOW or HIGH.

### Note

You can change the setting only when SDI signal is input.

## AUDIO SETTING

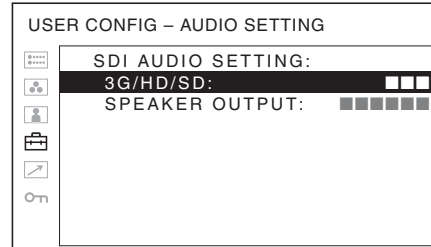

Submenu	Setting
SDI AUDIO SETTING	<p>Sets the audio channel when SDI signal is input.</p> <ul style="list-style-type: none"> <li>• <b>3G/HD/SD</b>: Selects from among channels CH1 to CH16, odd channel + even channel (CH1+CH2, CH3+CH4...CH15+CH16) and OFF.</li> </ul> <p>You can display the L/R audio levels of the selected channels. (see WFM/ALM/VECTOR (waveform monitor, audio level meter, and vectorscope) SETTING on page 27).</p> <ul style="list-style-type: none"> <li>• <b>SPEAKER OUTPUT</b>: Select an audio format to output from speakers, headphone jack, and AUDIO OUT connector. <ul style="list-style-type: none"> <li><b>EMBEDDED</b>: Outputs an audio signal embedded in SDI.</li> <li><b>ANALOG</b>: Outputs an audio signal that comes from the AUDIO IN connector.</li> </ul> </li> </ul>

### Note

The SDI audio signal is compatible only with 24 bit.

## REMOTE menu

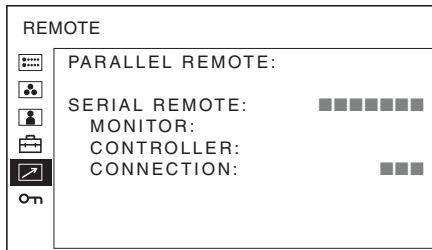

## PARALLEL REMOTE

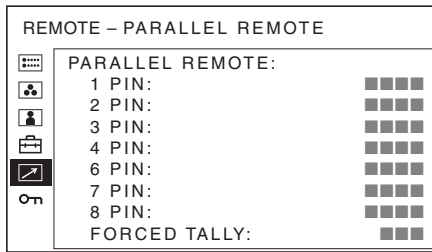

Submenu	Setting
PARALLEL REMOTE	<p>Selects the PARALLEL REMOTE connector pins for which you want to change the function. You can assign various functions to 1 to 4 pins and 6 to 8 pins. The following lists the functions you can assign to the pins.</p> <ul style="list-style-type: none"> <li>• ---- (“----”: No function is assigned.)</li> <li>• COMPOSITE</li> <li>• HDMI</li> <li>• SDI 1</li> <li>• SDI 2</li> <li>• WFM/ALM/VS</li> <li>• OVERSCAN</li> <li>• NORMAL</li> <li>• NATIVE</li> <li>• 4:3</li> <li>• 16:9</li> <li>• TALLY R</li> <li>• TALLY G</li> <li>• BLUE ONLY</li> <li>• MONO</li> <li>• H/V DELAY</li> <li>• 16:9 MARKER</li> <li>• 15:9 MARKER</li> <li>• 14:9 MARKER</li> <li>• 13:9 MARKER</li> <li>• 1.85:1 MARKER</li> <li>• 2.35:1 MARKER</li> <li>• 1.85:1 &amp; 4:3 MARKER</li> <li>• 4:3 MARKER</li> <li>• CENTER MARKER</li> <li>• MARKER MAT HALF</li> <li>• SAFE AREA 80%</li> <li>• SAFE AREA 85%</li> <li>• SAFE AREA 88%</li> <li>• SAFE AREA 90%</li> <li>• SAFE AREA 93%</li> <li>• FLICKER FREE</li> </ul>

### Notes

- If you use the PARALLEL REMOTE function, you need to connect cables. For more details, see page 36.
- Set MARKER ENABLE (page 27) to ON to control the aspect marker and center marker.



Submenu	Setting
FORCED TALLY	<p>The tally lamp function is forcibly assigned to 7 pin and 8 pin of the PARALLEL REMOTE connector. Selecting ON assigns tally lamp green to 7 pin and tally lamp red to 8 pin.</p> <p><b>ON:</b> Forcibly assigns the tally lamp function.  <b>OFF:</b> The tally lamp function is not forcibly assigned.</p>
<p><b>Note</b></p> <p>When OFF is selected, any listed functions can be assigned to 7 and 8 pins. Selecting ON with any function other than the tally lamp assigned to 7 and 8 pins will ignore this setting, and the tally lamp is forcibly assigned to 7 and 8 pins instead.</p>	

## SERIAL REMOTE

Submenu	Setting
SERIAL REMOTE	<p>Selects the mode to be used.</p> <ul style="list-style-type: none"> <li><b>OFF:</b> SERIAL REMOTE does not function.</li> <li><b>ETHERNET:</b> The monitor is controlled by the command of Ethernet.</li> <li><b>BKM-15R/16R:</b> Sets BKM-15R or BKM-16R.</li> </ul>
MONITOR	<p>Sets the monitor setting.</p> <p><b>MONITOR ID:</b> Sets the ID of the monitor.  <b>GROUP ID:</b> Sets the group ID of the monitor.  <b>IP ADDRESS:</b> Sets the IP address.  <b>SUBNET MASK:</b> Sets the subnet mask.  (255.255.255.000)  <b>DEFAULT GATEWAY:</b>  Sets the default gateway on or off.  <b>ADDRESS:</b> Sets the default gateway.  <b>CANCEL:</b> Selects to cancel the setting.  <b>CONFIRM:</b> Selects to save the setting.</p>
CONTROLLER	<p>Sets the address of the remote controller.</p> <p><b>IP ADDRESS:</b> Sets the IP address.  <b>SUBNET MASK:</b> Sets the subnet mask.  (255.255.255.000)  <b>DEFAULT GATEWAY:</b>  Sets the default gateway on or off.  <b>ADDRESS:</b> Sets the default gateway.  <b>CANCEL:</b> Selects to cancel the setting.  <b>CONFIRM:</b> Selects to save the setting.</p>
CONNECTION	<p>Sets the connection of the monitor and the controller.</p> <p><b>PEER TO PEER:</b> for one to one connection  <b>LAN:</b> for connection via a network</p>

## KEY INHIBIT menu

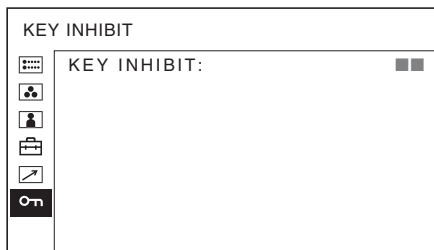

You can lock the setting so that they cannot be changed by an unauthorized user.

Select OFF or ON.

If you set to ON, all items are displayed in black, indicating the items are locked.

---

## Troubleshooting

This section may help you isolate the cause of a problem and as a result, eliminate the need to contact technical support.

- **The unit cannot be operated** → The key protection function works. Set the KEY INHIBIT setting to OFF in the KEY INHIBIT menu.

Or, a function that does not work is assigned. Press the RETURN button to check the assigned functions.

- **The black bars appear at the upper and lower positions of the display** → When the signal aspect ratio is different from that of the panel, the black bars appear. This is not a failure of the unit.
- **Adjustments and settings cannot be made** → Adjustments and settings may not be possible depending on the input signals and the status of the unit. See “Input Signals and Adjustable/Setting Items” (page 12).

# Specifications

## Picture performance

Panel	OLED panel
Picture size (diagonal)	
	PVM-2541: 623.4 mm (24 <sup>5</sup> / <sub>8</sub> inches)
	PVM-1741: 419.7 mm (16 <sup>5</sup> / <sub>8</sub> inches)
Effective picture size (H × V)	
	PVM-2541: 543.4 × 305.6 mm (21 <sup>1</sup> / <sub>2</sub> × 12 <sup>1</sup> / <sub>8</sub> inches)
	PVM-1741: 365.8 × 205.7 mm (14 <sup>1</sup> / <sub>2</sub> × 8 <sup>1</sup> / <sub>8</sub> inches)
Resolution (H × V)	1920 × 1080 pixels (Full HD)
Aspect	16:9
Pixel efficiency	99.99%
Panel drive	RGB 10-bit
Viewing angle (Panel specification)	89°/89°/89°/89° (typical) (up/down/left/right, contrast > 10:1)
Normal scan	0% scan
Over scan	5% over scan
Color temperature	D65, D93
Warm-up time	Approx. 30 minutes To provide stable picture quality, turn on the power of the monitor and leave it in this state for more than 30 minutes.

## Input

Composite input (NTSC/PAL) connector	BNC type (1) 1 V <sub>p-p</sub> ± 3 dB sync negative
SDI input connector	BNC type (2)
HDMI input connector	HDMI (1) HDCP correspondence
Audio input connector	Stereo mini jack (1) -5 dBu 47 kΩ or higher
Remote input connector	
Parallel remote	Modular connector 8-pin (1)
Serial remote	RJ-45 modular connector (1) (ETHERNET, 10BASE-T/ 100BASE-TX)
DC IN connector	PVM-1741: XLR 4-pin (male) (1) DC 12 V (output impedance 0.05 Ω or less)

## Output

SDI (3G/HD/SD) output connector	BNC type (1) Output signal amplitude: 800 mV <sub>p-p</sub> ±10% Output impedance: 75 Ω unbalanced
Composite output connector	BNC type (1) Loop-through, with 75 Ω automatic terminal function
Audio monitor output connector	Stereo mini jack (1)
Built-in speaker output	1.0 W Monaural
Headphones output connector	Stereo mini jack (1)

## General

Power	PVM-2541: AC 100 to 240 V, 1.4 A to 0.6 A, 50/60 Hz PVM-1741: AC 100 to 240 V, 1.0 A to 0.5 A, 50/60 Hz DC 12 V, 7.0 A
Power consumption	PVM-2541: Approx. 130 W (max.) Approx. 88 W (average power consumption in the default status) PVM-1741: Approx. 90 W (max.) Approx. 70 W (average power consumption in the default status)
Inrush current	PVM-2541: (1) Maximum possible inrush current at initial switch-on (Voltage changes caused by manual switching): 40 A peak, 8 A r.m.s. (240V AC) (2) Inrush current after a mains interruption of five seconds (Voltage changes caused at zero-crossing): 40 A peak, 8 A r.m.s. (240V AC) PVM-1741: (1) Maximum possible inrush current at initial switch-on (Voltage changes caused by manual switching): 35 A peak, 7 A r.m.s. (240V AC) (2) Inrush current after a mains interruption of five seconds (Voltage changes caused at zero-crossing): 35 A peak, 7 A r.m.s. (240V AC)
Operating conditions	Temperature 0 °C to 35 °C (32 °F to 95 °F) Recommended temperature

20 °C to 30 °C (68 °F to 86 °F)  
 Humidity 30% to 85% (no condensation)  
 Pressure 700 hPa to 1060 hPa  
 Storage and transport conditions  
 Temperature

–20 °C to +60 °C (–4 °F to +140 °F)

Humidity 0% to 90%

Pressure 700 hPa to 1060 hPa

Accessories supplied

- AC power cord (1)
- AC plug holder (1)
- Mounting bracket (2) (including 4 screws) (PVM-1741 only)
- Operating Instructions (1)
- CD-ROM (1)
- Using the CD-ROM Manual (1)

Optional accessories

- Monitor stand  
SU-561

Design and specifications are subject to change without notice.

Note

Always verify that the unit is operating properly before use. SONY WILL NOT BE LIABLE FOR DAMAGES OF ANY KIND INCLUDING, BUT NOT LIMITED TO, COMPENSATION OR REIMBURSEMENT ON ACCOUNT OF THE LOSS OF PRESENT OR PROSPECTIVE PROFITS DUE TO FAILURE OF THIS UNIT, EITHER DURING THE WARRANTY PERIOD OR AFTER EXPIRATION OF THE WARRANTY, OR FOR ANY OTHER REASON WHATSOEVER.

Pin assignment

PARALLEL REMOTE connector

Modular connector  
(8-pin)

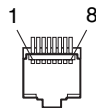

Pin number	Functions
1	Designating SDI 1 input signal
2	Designating HDMI input signal
3	Designating composite input signal
4	TALLY G
5	GND
6	TALLY R
7	OVERSCAN
8	NORMAL

You can allocate functions using the REMOTE menu (see page 32).

Note

Switching functions continuously allows at least 200 msec to do so. Otherwise, it may not switch correctly.

Wiring required to use the Remote Control

Connect the function you want to use with a Remote Control to the Ground (Pin 5).

Available signal formats

The unit is applicable to the following signal formats.

System	Compo site	SD/HD	3G	HDMI
575/50i (PAL)	○	○	–	○
480/60i (NTSC)*1	○	○	–	○
576/50p	–	–	–	○
480/60p*1	–	–	–	○
640 × 480/60p*1	–	–	–	○
1080/24PsF*1*2	–	○	○*3	–
1080/25PsF*2	–	○	○*3	–
1080/30PsF*1*2	–	–	○*3	–
1080/24p*1	–	○	○*3	○
1080/25p	–	○	○*3	○
1080/30p*1	–	○	○*3	○
1080/50i	–	○	○*3	○
1080/60i*1	–	○	○*3	○
1080/50p	–	–	○*4	○*6
1080/60p*1	–	–	○*4	○*6
720/24p*1	–	–	○*5	–
720/25p	–	–	○*5	–
720/30p*1	–	–	○*5	–
720/50p	–	○	○*3	○*6
720/60p*1	–	○	○*3	○*6

○ : Adjustable/can be set

– : Not adjustable/cannot be set

\*1 Compatible with 1/1.001 frame rates.

\*2 1080/24PsF, 25PsF, and 30PsF are displayed as 1080/48i, 50i, and 60i on the screen, respectively.

\*3 10-bit 4:4:4 Y/Cb/Cr and 4:4:4 RGB of 3G-SDI signals are supported.

\*4 10-bit 4:2:2 Y/Cb/Cr of 3G-SDI signal is supported.

\*5 10-bit 4:4:4 Y/Cb/Cr of 3G-SDI signal is supported.

\*6 Also available when a DVI signal is input with a DVI conversion cable connected to the HDMI IN connector.

## Applicable DVI input signals from PC

When a DVI signal is input to the HDMI IN connector using a DVI conversion cable

Resolution	Dot clock (MHz)	fH (kHz)	fV (Hz)
640 × 480	25.175	31.5	60
1280 × 768	68.250	47.4	
1280 × 1024	108.000	64.0	
1360 × 768	85.500	47.7	
1440 × 900	88.750	55.5	
1680 × 1050	119.000	64.7	

### Note

The sides of the displayed picture may be hidden depending on the input signal.

# Dimensions

**PVM-2541**

**Front**

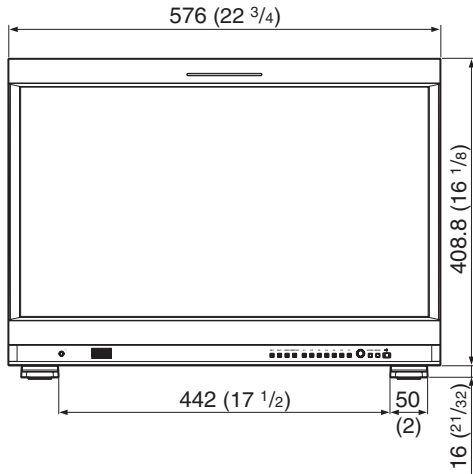

**Rear**

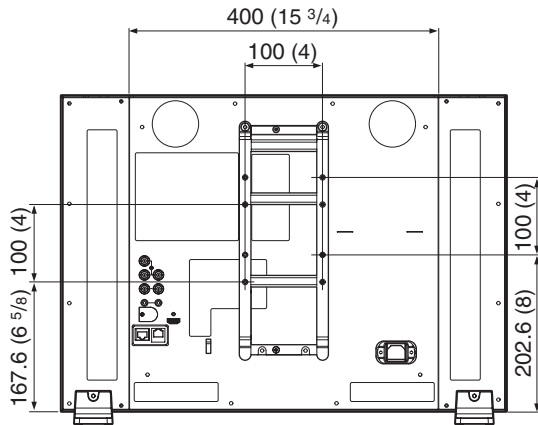

**Side**

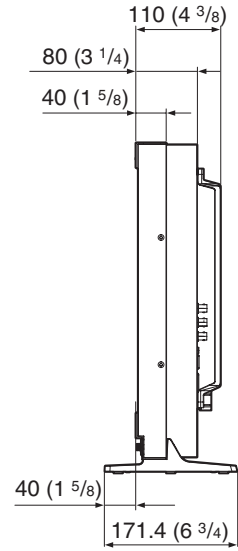

**Front (with optional monitor stand SU-561)**

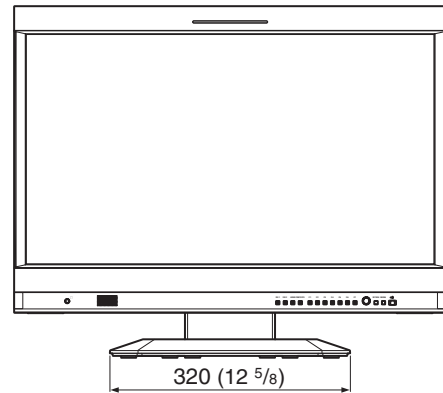

**Side (with optional monitor stand SU-561)**

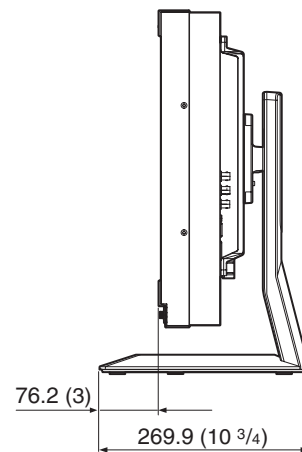

Unit: mm (inches)

**Mass:**

Approx. 10.6 kg (23 lb 5.9 oz)

Approx. 12.7 kg (27 lb 16 oz) (with monitor stand SU-561)

# PVM-1741

## Front

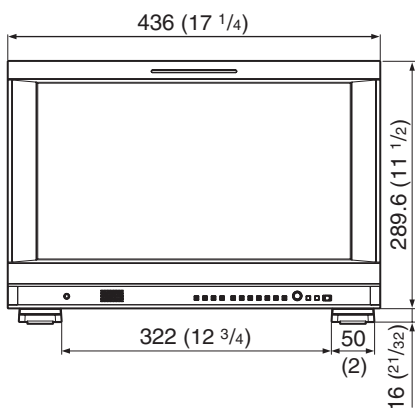

## Rear

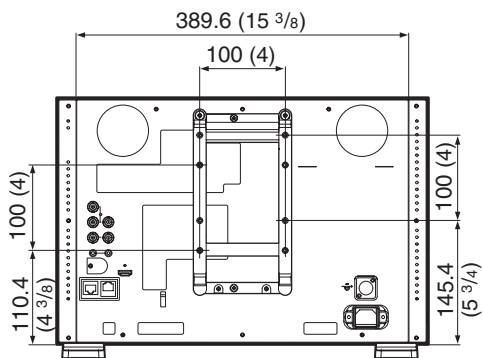

## Side

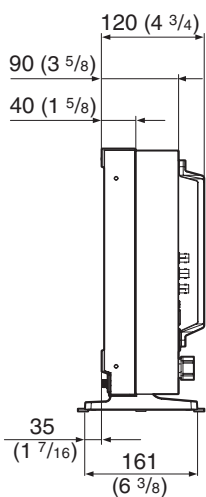

## Front (with optional monitor stand SU-561)

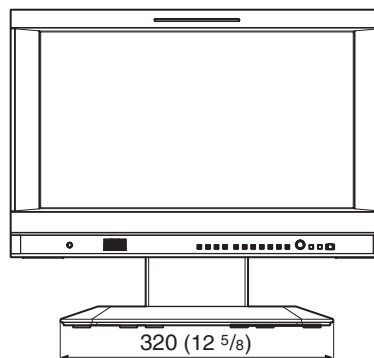

## Side (with optional monitor stand SU-561)

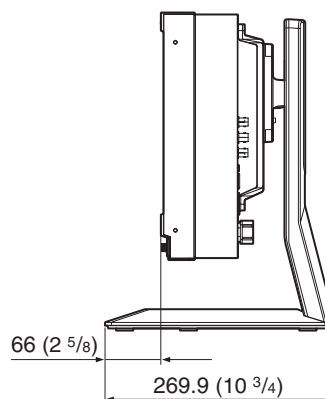

Unit: mm (inches)

## Mass:

Approx. 7.2 kg (15 lb 14 oz)

Approx. 9.3 kg (20 lb 8.0 oz) (with monitor stand SU-561)

