

TRINITRON® COMPONENT TV

KX-1901/2501

OPERATING INSTRUCTIONS

Before operating the set, please read this manual thoroughly, and retain it for future reference.

For detailed instructions for system connections, see the separate booklet "SYSTEM CONNECTION GUIDE".



PROFEEL

OWNER'S RECORD

The model and serial numbers are located at the rear. Record these numbers in the spaces provided below. Refer to them whenever you call upon your Sony dealer regarding this product.

Model No. _____ Serial No. _____

CONTENTS

Warning	2
Precautions	2
Features	3
Trinitron color system	4
Location and function of parts and controls	5
Specifications	12

WARNING

To prevent fire or shock hazard, do not expose the set to rain or moisture.

Dangerously high voltages are present inside the set. Do not open the cabinet. Refer servicing to qualified personnel only.

PRECAUTIONS

USE

- Operate only on 120 V ac.
- This set is equipped with a polarized AC power cord plug (one blade of the plug is wider than the other), which will fit into the power outlet only one way. Should you be unable to insert the plug fully into the outlet, try reversing the plug. If the plug still fails to fit, contact your dealer for assistance. Do not defeat the safety purpose of the polarized plug.
- Should any liquid or solid object fall into the cabinet, unplug the set and have it checked by qualified personnel before operating it any further.
- Unplug the set from the wall outlet if it is not to be used for several days.
- To disconnect the cord, pull it out by the plug. Never pull the cord itself.

INSTALLATION

- Allow adequate air circulation to prevent internal heat build-up. Do not place the set on surfaces (rugs, blankets, etc.) or near materials (curtains, draperies) that may block the ventilation holes.
- Do not install the set in a location near heat sources such as radiators or air ducts, or in a place subject to direct sunlight, excessive dust, mechanical vibration or shock.

MAINTENANCE

- Save the original shipping carton and packing material; they will come in handy if you ever have to ship your set. For maximum protection, repack your set as it was originally packed at the factory.
- To keep the set looking brand-new, periodically clean it with a soft cloth. Stubborn stains may be removed with a cloth lightly dampened with a mild detergent solution. Never use strong solvents such as thinner or benzine, or abrasive cleansers since these will damage the cabinet. As a safety precaution, unplug the set before cleaning it.
- For cleaning the screen, the front glass may be removed by loosening the screws with a coin. Be careful when removing the glass as it is heavy.

For detailed safety precautions, see the leaflet "IMPORTANT SAFEGUARDS" included with this manual in the vinyl bag.

WARNING: This equipment has been certified to comply with the limits for a class B computing device, pursuant to Subpart J of Part 15 of FCC rules. Only peripherals (computer input/output devices, terminals, printers, etc.) and/or computers certified to comply with the class B limits may be attached to this equipment. Operation with non-certified peripherals and/or computers is likely to result in interference to radio and TV reception.

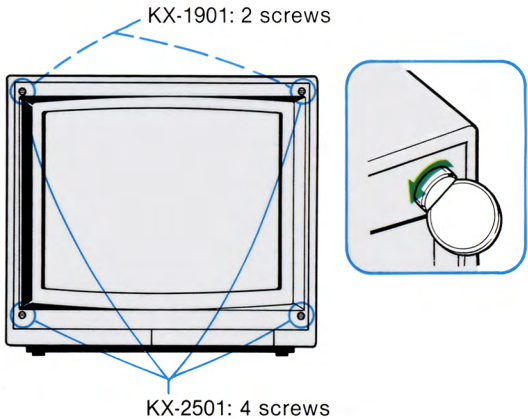

A color video monitor designed for a variety of uses with a Sony Component TV tuner, Sony Betamax videocassette recorder, video camera, character generator, microcomputer, etc.

Dynamic Picture system adjusts picture contrast automatically to produce more detail in both bright and dark areas of every scene.

Dynamic Color system for superior color reproduction with natural facial color tones and dazzling whites.

Colorpure Filter that produces fine picture detail without color spill or color noise.

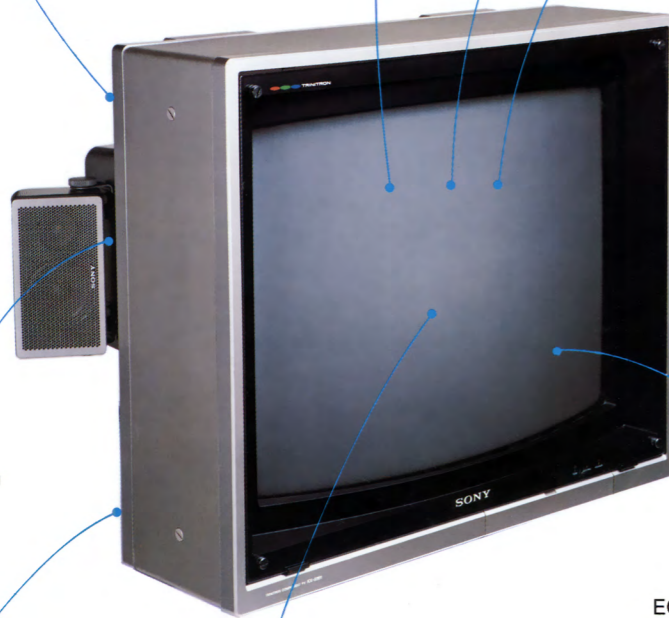

Two built-in audio amplifiers provide dynamic sound from an externally connected speaker system (optional).

When the Component TV is used with a Component TV tuner, the volume, picture and power can be controlled from the tuner or the Remote Commander (supplied with the tuner).

Smoked glass over the picture tube for a glare-free picture with optimum contrast.

ECONOQUICK, energy-saving quick-start system.

The KX-2501 also features:

- A Velocity Modulation scanning system for increased sharpness and resolution.
- Pulse techniques in the power supply section that provide an efficient and stable power supply.

The Sony Component TV as well as the conventional Sony Color TV employs the unique Trinitron Color System. A product of intensive engineering research, the Trinitron Color System provides a brighter and sharper picture, with simplified and more accurate service adjustments.

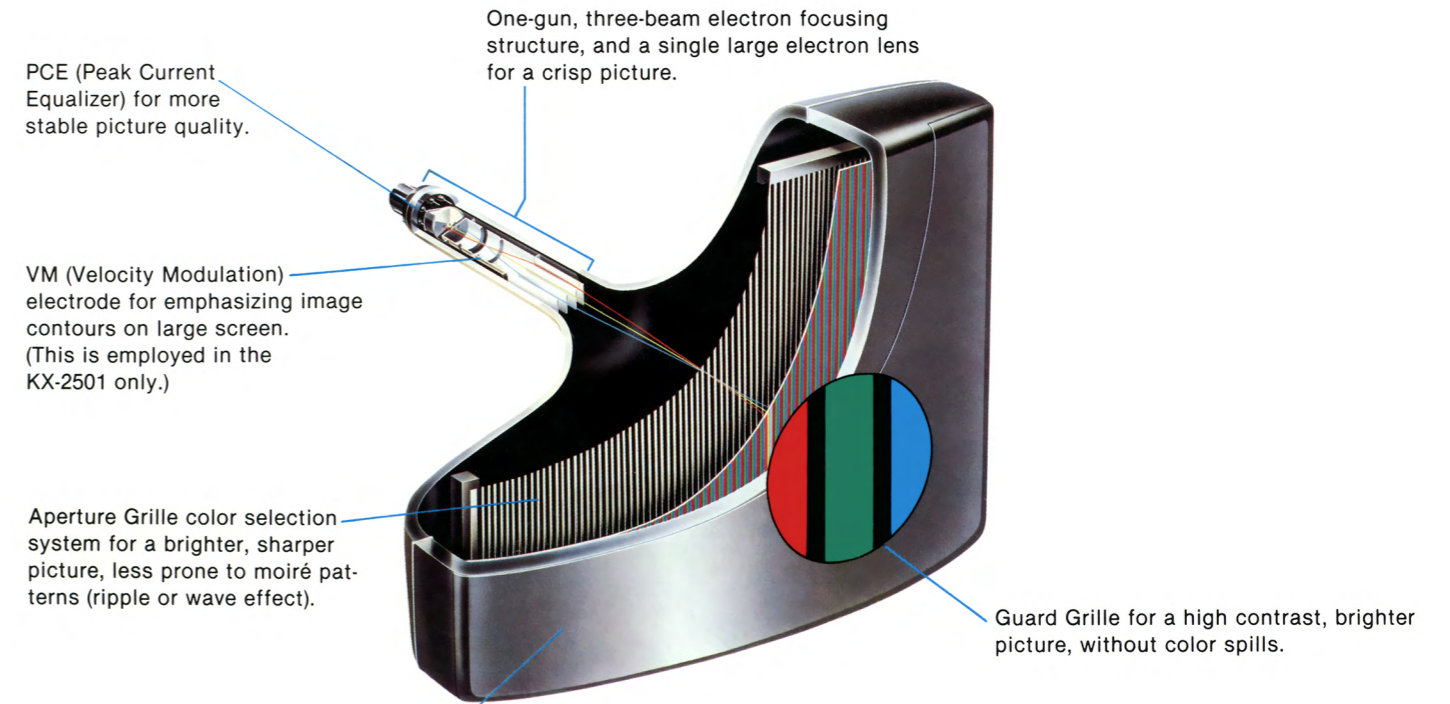

Cylindrical screen reduces distortion as viewed from the sides (A), sharpens the picture corners (B), and diminishes room reflections (C).



A and B are simulated pictures.

LOCATION AND FUNCTION OF PARTS AND CONTROLS

(behind panel)

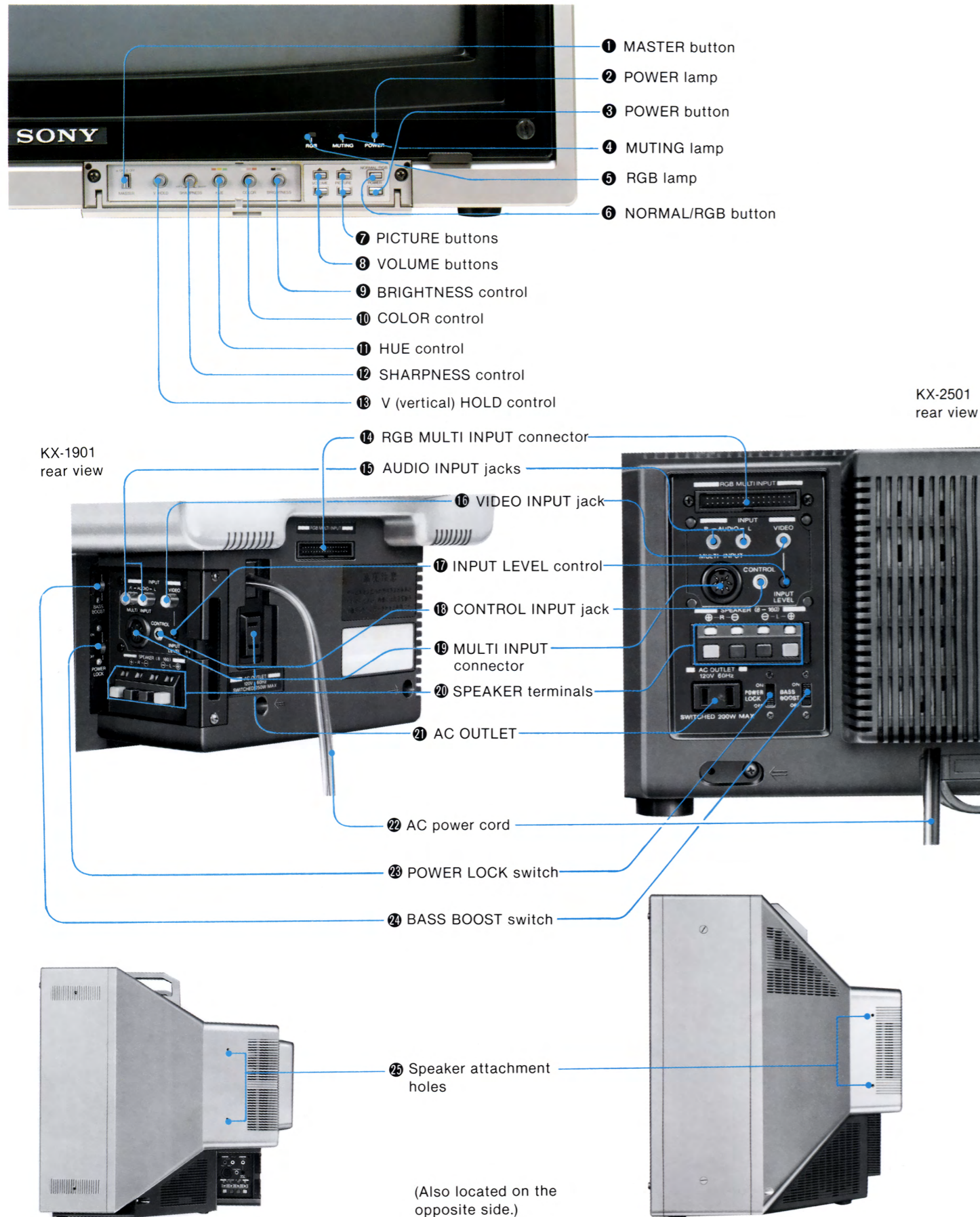

- 1 MASTER button
- 2 POWER lamp (green)
- 3 POWER button

Normally, keep the MASTER button depressed and switch the set on or off with the POWER button.

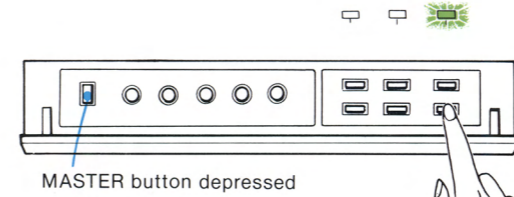

Press the POWER button to turn the set on. The POWER lamp will light.

To switch the set off, press the POWER button again. If the set is not to be used for an extended period of time, press the MASTER button to OFF.

When the set is used with a Sony Component TV tuner, be sure to keep the MASTER button depressed to be able to operate the set with the controls on the tuner or the Remote Commander (supplied with the tuner).

The Component TV functions as follows with the MASTER or the POWER button operation:

	When turned off with POWER button and turned on again.	When turned off with MASTER button and turned on again.
6 NORMAL/RGB setting		NORMAL
7 PICTURE setting	memorized	factory-preset levels
8 VOLUME setting		

- 4 MUTING lamp (red)

When the set is used with a Sony Component TV tuner and the MUTING key on the Remote Commander (supplied with the tuner) is pressed, the sound will be muted and this lamp will light. To release the sound muting on this set, press the VOLUME ▲ button or turn the set off and on again with the POWER button.

- 5 RGB lamp (amber)
- 6 NORMAL/RGB button

When the set is turned on with the MASTER button and POWER button, NORMAL will be selected automatically.

NORMAL: for monitoring signals from the AUDIO/VIDEO/CONTROL INPUT 15 16 18 jacks or the MULTI INPUT 19 connector

RGB: for monitoring video signals from the RGB MULTI INPUT 14 connector (The sound from the AUDIO INPUT 15 jack or the MULTI INPUT 19 connector will be heard.)

To set to RGB, press the NORMAL/RGB button. The RGB lamp will light.



Good picture

- 7 PICTURE buttons

These buttons adjust the contrast, color intensity and brightness simultaneously in the proper ratio.

strong contrast with vivid color



good picture

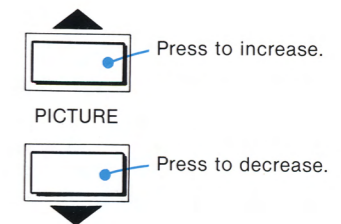

weak contrast with pale color

- 8 VOLUME buttons

These buttons adjust the sound volume.

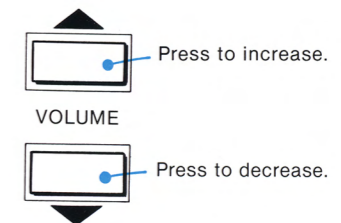

9 BRIGHTNESS control

Adjust the brightness.
Normally set this control at the center detent position.
The newly-developed Dynamic Picture system makes it unnecessary to make frequent adjustments.

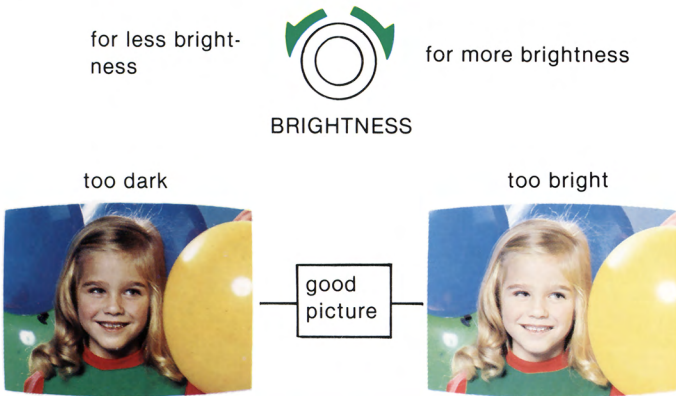

10 COLOR control

Adjusts the color intensity.
Normally set this control at the center detent position.

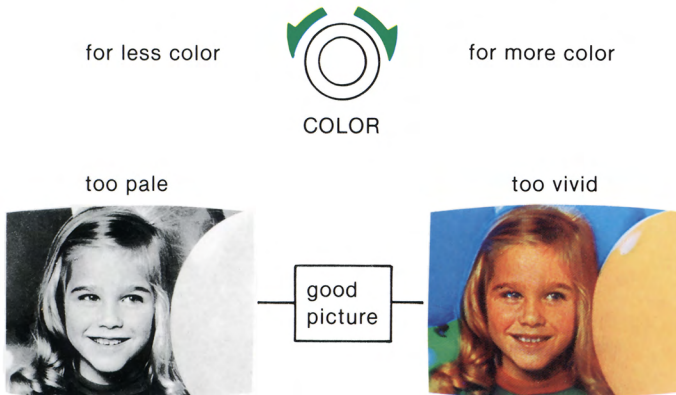

11 HUE control

Adjusts the hue to give the most natural skin tones.
Normally set this control at the center detent position.

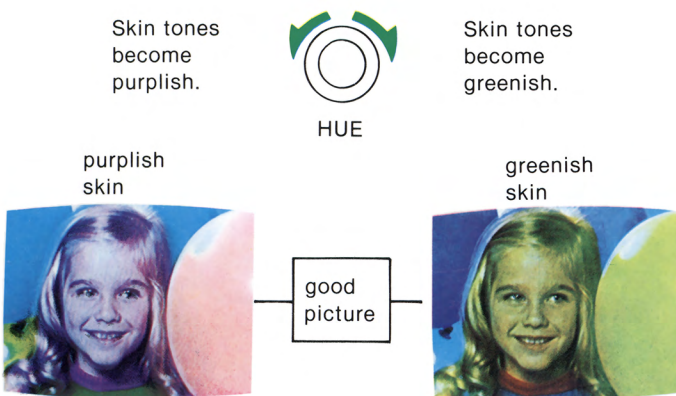

12 SHARPNESS control

Adjusts the sharpness.
Normally set this control at the center detent position.

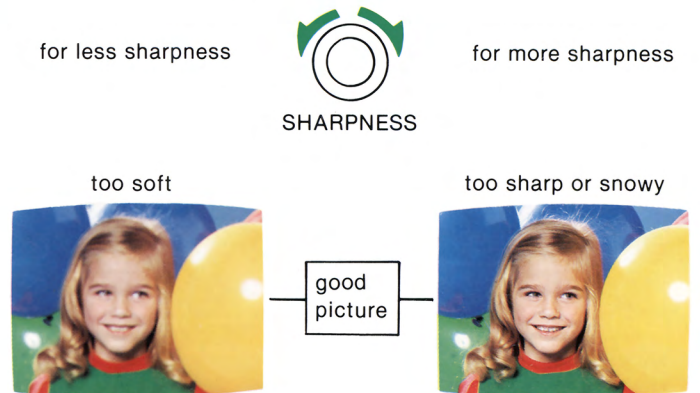

13 V HOLD control

If the picture rolls vertically, adjust this control until the picture stabilizes.



RGB MULTI INPUT connector (34-pin plug)

This connector allows a character generator, microcomputer, or a special adaptor for future multiplex letter information broadcasts having digital RGB outputs to be connected. The connector cover has been attached to this connector at the factory. When this connector is not in use, keep the cover attached.

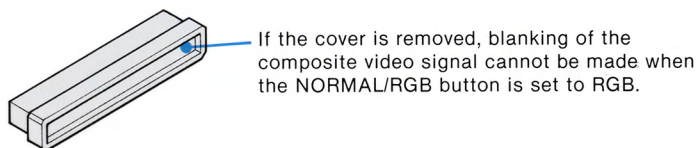

When such equipment having digital RGB outputs is connected to this connector, disconnect the connector cover and proceed as follows by using the supplied 34-pin socket.

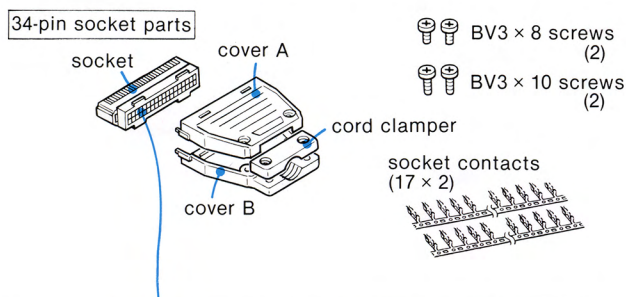

Position number	Signal to be connected	Position number	Signal to be connected
1	not in use	18	not in use
2	not in use	19	not in use
3	Ground	20	not in use
4	Ground	21	Level select
5	Ground	22	not in use
6	Ground	23	not in use
7	Ground	24	not in use
8 *	Ground (red return)	25 *	Red input
9 *	Ground (green return)	26 *	Green input
10 *	Ground (blue return)	27 *	Blue input
11	Ground	28	not in use
12 *	Ground (blanking return)	29 *	Blanking input
13 *	Ground (composite sync return)	30 *	Composite sync or H sync
14	not in use	31	V sync
15	Ground	32	Half blanking
16	Ground	33	Normal/RGB select
17	not in use	34	not in use

*For No. 25 and 8, 26 and 9, 27 and 10, 29 and 12, or 30 and 13 connections, use a twisted-pair lead when the signal level is TTL, or a coaxial cable when the signal level is 1V p-p.

(1) Solder each lead to a socket contact.

1. Place the lead on the contact as illustrated.

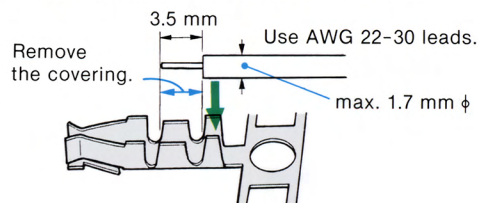

2. Fix the lead.

3. Tighten the tabs slightly.



4. Solder the conductor.

Take care not to solder past the point indicated by the dotted line.

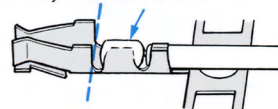

5. After soldering, separate the contact by moving it upwards and downwards.

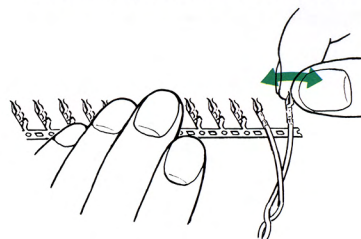

(2) Connect the socket contacts to the correct positions. Refer to the chart.

Align the contact and lead for easier insertion.

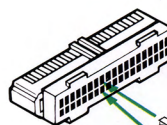

For positions 18-34, insert with the flat side upwards.

For positions 1-17, insert with the flat side downwards.

(3) Assemble the socket.

1. Attach the socket to the cover B.

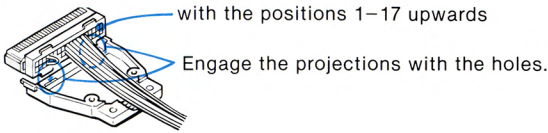

2. Attach the cover A to the socket with the 2 shorter screws.



3. Attach the cord clumper with the 2 longer screws.

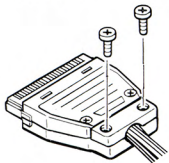

(4) Connect the socket to the RGB MULTI INPUT connector.

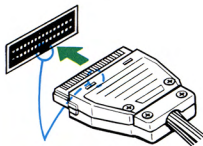

Engage the projection with this slot.

For the signal specifications, see page 12.

Example

Microcomputer

Component TV
34-pin connector

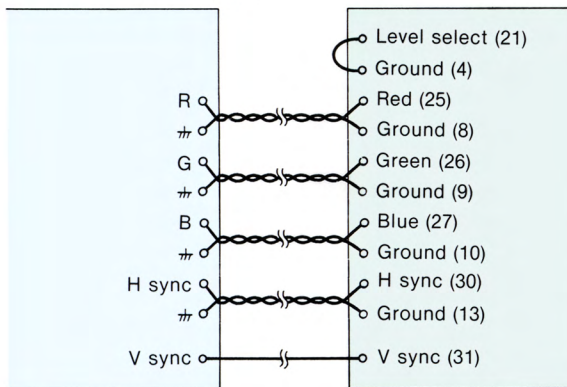

15 AUDIO INPUT jacks (phono jacks, L-white, R-red)

Connect to the audio outputs of a Sony Betamax or U-matic videocassette recorder, Sony Component TV tuner, etc. Connect the L and R channels properly. If the recorder is monaural, connect the audio output of the recorder to these two jacks with the RK-105A Connecting Cord (supplied) and the PC-5A Plug Adaptor (phono plug to minijack, optional), if required.

16 VIDEO INPUT jack (phono jack, yellow)

17 INPUT LEVEL control

Connect to the video output of a Sony Betamax or U-matic videocassette recorder, Sony Component TV tuner, video camera, etc. with the VMC-1S Video Cable (supplied).

The input level of the video signal from this jack can be adjusted with the INPUT LEVEL control.

Normally set the control to the center detent position.

If the picture contrast is too weak or too strong, adjust the level (min. 0.5V p-p, max. 2V p-p) by turning the control clockwise or counterclockwise with a screwdriver.

18 CONTROL INPUT jack (minijack)

When the set is used with a Sony Component TV tuner equipped with a control output connector, connect as illustrated with the RK-69A Connecting Cord (optional).

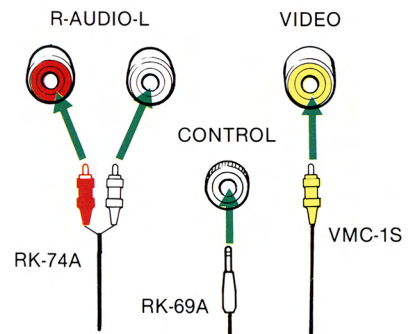

The volume and picture can be adjusted and the power can be turned on or off using the controls on the TV tuner or the Remote Commander (supplied with the tuner).

19 MULTI INPUT connector (8-pin DIN)

Connect to the MULTI OUTPUT (8-pin DIN) connector on a Sony Component TV tuner with the VK-2D Video Cable (supplied with the tuner, 2 m). The audio, video and control signals can be connected simultaneously with this cable.

The volume and picture can be adjusted and the power can be turned on or off using the controls on the TV tuner or the Remote Commander (supplied with the tuner).

Engage this projection with this slot.

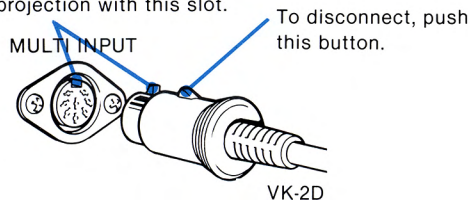

The VK-5DX Video Cable is available optionally for extending the VK-2D.

Caution: Use either the VIDEO/AUDIO/CONTROL 15 16 18 jacks or the MULTI INPUT connector, but not both simultaneously.

20 SPEAKER terminals

Connect to an 8–16 ohms speaker system.

Speaker cord connections

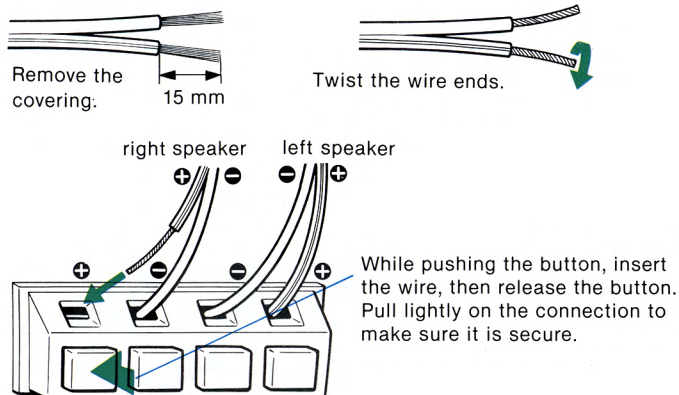

Caution

- Make sure that none of the strands are separated from the wire and shorts across the speaker terminals.
- Correct \oplus \ominus connection of both speakers insures proper in-phase operation. If the speaker system is out-of-phase, the bass tones seem to be missing and the position of the instruments becomes obscure.
- The set should be placed some distance away from the speakers so that it will not be affected by the speaker magnets. If a temporary proximity to magnets should cause portions of the picture to have poor color, turn the POWER button off, and after about 10 minutes, turn it on. The Sony SS-X1A and SS-X10A Speaker System (optional) may be placed near the set because these are a low magnetic flux leakage type.
- Never connect a speaker system to an amplifier and this Component TV simultaneously, as this may damage the TV.

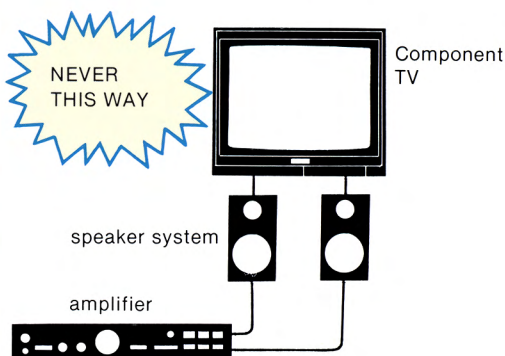

21 AC OUTLET (SWITCHED)

Provides ac power of 200 W max. (KX-2501) or 250 W max. (KX-1901) to other connected equipment. Power can be switched on and off with the POWER button on the Component TV.

Caution

- When the set is used with a Sony Component TV tuner, do not connect the ac power cord of the tuner to this outlet. Otherwise, the power cannot be turned on or off using the control on the tuner or the Remote Commander (supplied with the tuner).

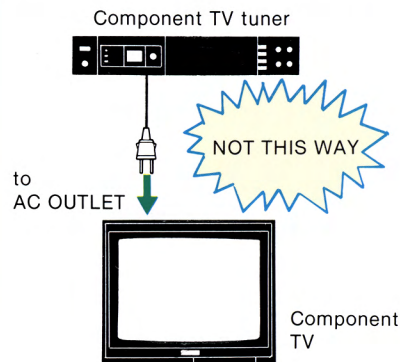

- Do not connect electrical home appliances such as an electric iron, fans, or other high-wattage equipment to this outlet.

22 AC power cord

Connect to a convenient 120 V ac wall outlet.
When the set is used with a Sony Component TV tuner, the ac power cord may be connected to the UNSWITCHED AC OUTLET.

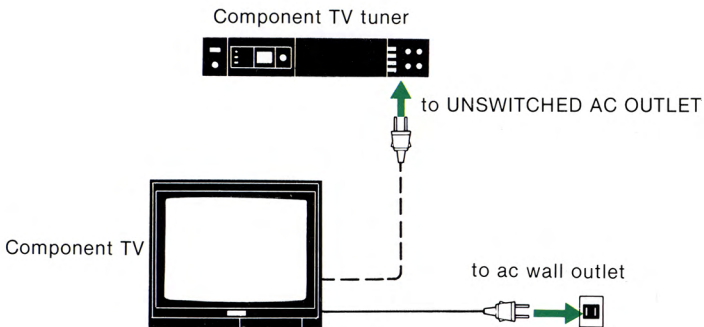

23 POWER LOCK switch

Normally set to OFF.
The MASTER and POWER buttons functions as described above.
If the set is to be switched on or off by a timer, set this switch to ON and keep the MASTER button pushed in.
When power is supplied to the set with the POWER LOCK switch and MASTER button set to ON, the set will turn on automatically.

24 BASS BOOST switch

When a bookshelf-type speaker system (e.g. Sony SS-X1A, SS-X10A) is used, set this switch to ON to enhance the bass sound.
When a larger speaker system is used, set the switch to OFF to prevent excessive bass boost.

25 Speaker attachment holes

The Sony SS-X1A Speaker System (optional) may be attached to the set. For details on attachment, see the instructions furnished with the SS-X1A.

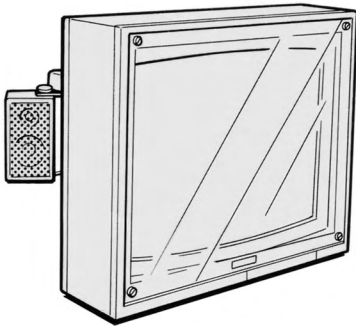

SPECIFICATIONS

Color system	NTSC
Picture tube	Trinitron tube KX-1901: 19-inch picture measured diagonally, 100-degree deflection KX-2501: 25-inch picture measured diagonally, 114-degree deflection
Inputs	VIDEO INPUT (phono jack) 1 V p-p, NTSC, 75 ohms, unbalanced, sync negative AUDIO INPUT (2 phono jacks) -5 dBs (436 mV rms), 47 kilohms CONTROL INPUT (minijack) 5V p-p MULTI INPUT (8-pin DIN) Same as the above VIDEO/AUDIO/ CONTROL INPUTS

RGB MULTI INPUT (34-pin plug)

Pin No.	Signal	Signal level
21	Level select	High state (open): for 1 V p-p Low state (ground): for TTL level
25 26 27	Red input Green input Blue input	Positive polarity ① 1 V p-p $\begin{matrix} +3 \\ -1 \end{matrix}$ dB, 75 ohms terminated, superimposed dc component 0-2 V ② TTL level ● ① or ② is selected by the pin 21.
29	Blanking input	Positive polarity High state (1-3 V), 75 ohms terminated Low state (0-0.4 V), 75 ohms terminated ● Displays RGB inputs only at high state, or RGB inputs superimposed directly on composite video inputs at low state.
30	Composite sync or H sync	Negative polarity ① 1 V p-p $\begin{matrix} +3 \\ -1 \end{matrix}$ dB, 75 ohms terminated, superimposed dc component 0-2 V ② TTL level ● ① or ② is selected by the pin 21.
31	V sync	Negative polarity TTL level
32	Half blanking	Positive polarity TTL level ● Active with the blanking input at low state. ● Decreases the contrast of the composite video inputs in superimposed mode.
33	Normal/RGB select	High state (10-12 V): RGB inputs Low state (0-2 V): Normal composite input ● The NORMAL/RGB button on the front panel does not function at high state.
3-13, 15, 16	Ground	
1, 2, 14, 17-20, 22-24, 28, 34	Not in use	

Output	SPEAKER Accepts speakers of 8–16 ohms
Power requirements	120V ac, 60 Hz
Power consumption	KX-1901: 142 W (max.) 93 W (average) KX-2501: 180 W (max.) 132 W (average)
AC outlet	KX-1901: Switched, max. 250 W KX-2501: Switched, max. 200 W
Dimensions	KX-1901: Approx. 504 × 452 × 480 mm (w/h/d) (19 ⁷ / ₈ × 17 ⁷ / ₈ × 19 inches) KX-2501: Approx. 660 × 560 × 487 mm (w/h/d) (26 × 22 ¹ / ₈ × 19 ¹ / ₄ inches)
Weight	KX-1901: Approx. 33 kg. (72 lb 12 oz) KX-2501: Approx. 55 kg (121 lb 4 oz)
Accessories supplied	Video Cable VMC-1S (phono plug to phono plug, 1.2 m) Connecting Cord RK-105A (miniplug to 2 phono plugs, 1.5 m) 34-pin socket 1 set

Design and specifications subject to change without notice.

OPTIONAL UNITS/ACCESSORIES

Component TV Tuner VTX-1000R
Remote Commander RM-705
Speaker System SS-X1A, SS-X10A
Betamax Videocassette Recorder SL-2000, SL-5000
Video Cable VK-2D (8-pin DIN plug to 8-pin DIN plug, 2 m)
VK-5DX (8-pin DIN socket to 8-pin DIN plug, 5 m)
Plug Adaptor PC-5A (phono plug to minijack)

