

Display

Date: **September 11, 1995**

Subject: **SHIELD PLATES FOR INTERFERENCE PROTECTION**

Model: **PVM-5041Q**

Serial No: **ALL**

DESCRIPTION

When asynchronous signals are fed to monitors mounted on MB-507 rack, horizontal stripe noise may appear in the picture. To reduce this noise, install shield plates as described in the following Modification Procedure.

MODIFICATION PROCEDURE

1. Remove positioning plate from bottom panel (Figure 2).

PARTS REQUIRED

Part No.	Description	Qty.
X-4033-031-1	Shield Kit	1*

* Kit consists of 3 shield plates (A) and 1 shield plate (B) (see Figure 1).

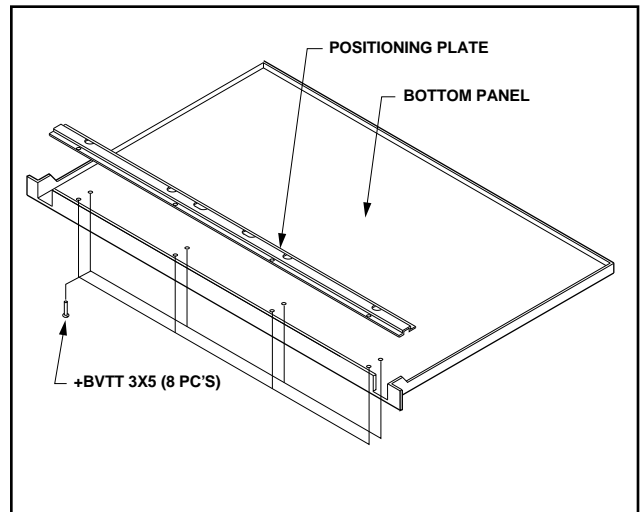

Figure 2

2. Install shield plate (A) (Figure 3.)

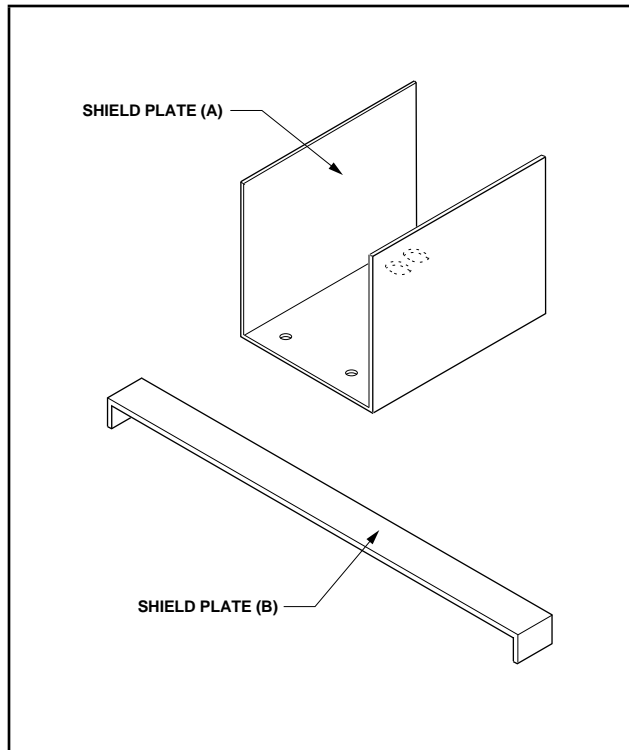

Figure 1

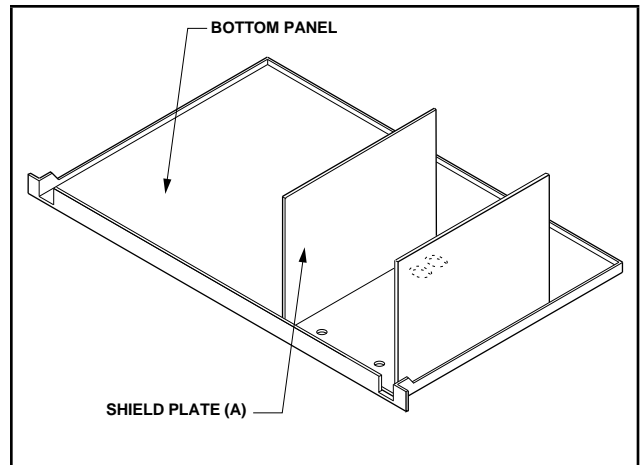

Figure 3

3. Install monitor in shield plate (A) and tighten shield plate (A) to the bottom panel. (See Figure 4). Install other monitors in the same manner.
4. Install shield plate (B) on monitors as shown in Figure 5.

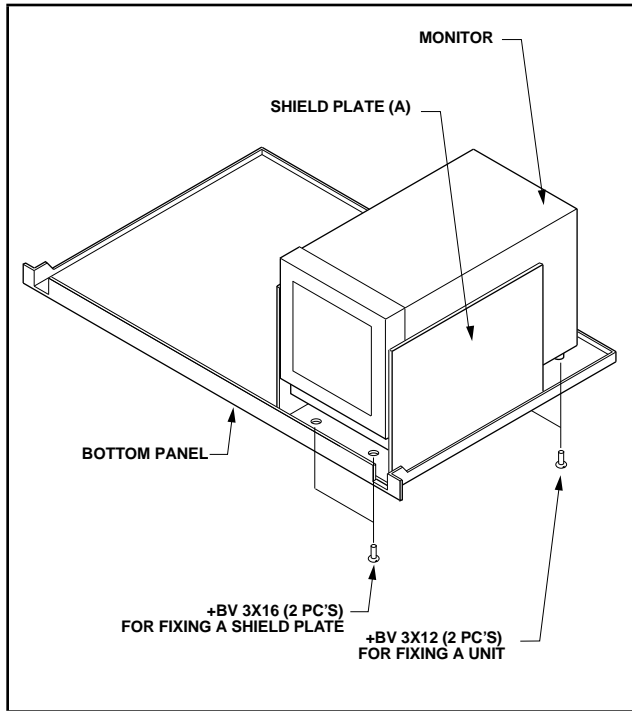

Figure 4

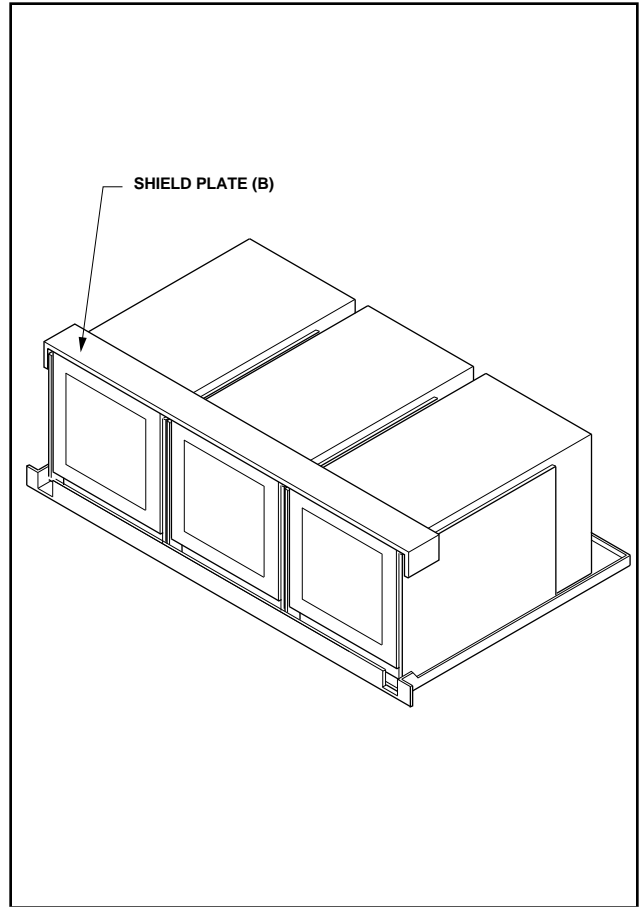

Figure 5