

PVM-8041Q/8044Q

SERVICE MANUAL

US Model
Canadian Model

PVM-8041Q

Chassis No. SCC-E96A-A

PVM-8044Q

Chassis No. SCC-E96C-A

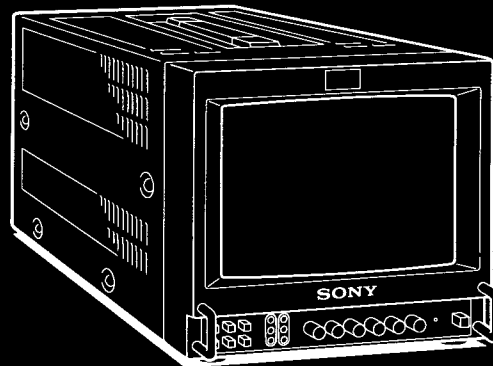

SPECIFICATIONS

Video signal

Color system	PAL, SECAM, NTSC _{3.58} , NTSC _{4.43}
Resolution	PVM-8044Q : 450 TV lines PVM-8041Q : 250 TV lines
Aperture correction	-4.0 dB - +6.0 dB (at 3.0 MHz)
Frequency response	6.0 MHz (-3.0 dB) at all inputs
Synchronization	AFC time constant 1.0 msec.

Picture performance

Normal scan	6% over scan of CRT effective screen area
Underscan	3% underscan of CRT effective screen area
H. linearity	Less than 7.0% (typical)
V. linearity	Less than 7.0% (typical)
Convergence	Central area: 0.43mm (typical) Peripheral area: 0.53mm (typical)
Raster size stability	H: 1.0%, V: 1.5%
High voltage regulation	3.0%
Color temperature	D65

Inputs and Outputs

Inputs	Y/C IN: 4-pin mini DIN connector (See the pin assignment on page 2.) VIDEO IN: BNC connector 1Vp-p \pm 6dB, sync negative AUDIO IN: phono jack, -5 dBs, less than 47k ohms
--------	--

R/R-Y, G/Y, B/B-Y: BNC connector
R, G, B channels: 0.7 Vp-p, \pm 6 dB
Sync on green : 0.3 Vp-p, negative,
75 ohms terminated
R-Y, B-Y channels: 0.7 Vp-p, \pm 6 dB
Y channel: 0.7 Vp-p, \pm 6 dB
(Standard color bar signal of 75% chrominance)
EXT SYNC IN: BNC connector
Composite sync 4 Vp-p, \pm 6 dB,
negative

Loop-through outputs

Y/C OUT: 4-pin mini DIN connector
VIDEO OUT: BNC connector,
75 ohms terminated
AUDIO OUT: phono jack
EXT SYNC OUT: BNC connector,
75 ohms terminated
AUDIO OUTPUT 0.5W

Tally/remote input

TALLY/REMOTE: 8-pin mini DIN connector (See the pin assignment on page 2.)

General

Power consumption 45 W Max at AC operation
38 W at DC operation

- Continued on next page -

TRINITRON® COLOR VIDEO MONITOR
SONY®



Power requirements 120V AC, 50/60 Hz
 12V DC, with the Sony NP-1A/1B
 battery pack (not supplied) or
 AC-500 AC power adaptor
 (not supplied)

Operating temperature range
 0 – 35 °C

Storage temperature range
 -10 – +40 °C

Humidity
 0 – 90%

Dimensions
 Approx. 217 x 217 x 352.5 mm (w/h/d)
 (8 5/8 x 8 5/8 x 14 inches)
 not incl. projecting parts and controls

Weight
 Approx. 7.8 kg (17 lb 3 oz)
 not incl. battery packs

Accessory supplied AC power cord (1)

Design and specifications are subject to change without notice.

Pin Assignment

Y/C IN connector (4-pin mini DIN)

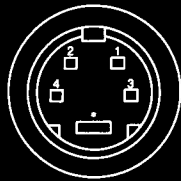

Pin No.	Signal	Description
1	Y-input	1 Vp-p, sync negative, 75 ohms
2	CHROMA sub-carrier-input	300 mVp-p, burst Delay time between Y and C: within 0±100 nsec., 75 ohms
3	GND for Y-input	GND
4	GND for CHROMA-input	GND

TALLY/REMOTE connector (8-pin mini DIN)

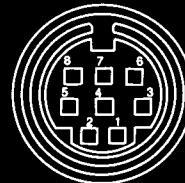

Pin No.	Signal
1	Blue only
2	H/V delay
3	GND
4	INT/EXT SYNC
5	Tally
6	Underscan/normal scan
7	A/B or RGB/component
8	RGB/LINE

For remote control, connect the pin of the desired function to pin 3 (GND).

SAFETY CHECK-OUT

(US Model only)

After correcting the original service problem, perform the following safety checks before releasing the set to the customer:

1. Check the area of your repair for unsoldered or poorly-soldered connections. Check the entire board surface for solder splashes and bridges.
2. Check the interboard wiring to ensure that no wires are "pinched" or contact high-wattage resistors.
3. Check that all control knobs, shields, covers, ground straps, and mounting hardware have been replaced. Be absolutely certain that you have replaced all the insulators.
4. Look for unauthorized replacement parts, particularly transistors, that were installed during a previous repair. Point them out to the customer and recommend their replacement.
5. Look for parts which, though functioning, show obvious signs of deterioration. Point them out to the customer and recommend their replacement.
6. Check the line cord for cracks and abrasion. Recommend the replacement of any such line cord to the customer.
7. Check the condition of the monopole antenna (if any). Make sure the end is not broken off, and has the plastic cap on it. Point out the danger of impalement on a broken antenna to the customer, and recommend the antenna's replacement.
8. Check the B+ and HV to see they are at the values specified. Make sure your instruments are accurate; be suspicious of your HV meter if sets always have low HV.
9. Check the antenna terminals, metal trim, "metallized" knobs, screws, and all other exposed metal parts for AC leakage. Check leakage as described below.

LEAKAGE

The AC leakage from any exposed metal part to earth ground and from all exposed metal parts to any exposed metal part having a return to chassis, must not exceed 0.5 mA (500 microamperes). Leakage current can be measured by any one of three methods.

1. A commercial leakage tester, such as the Simpson 229 or RCA WT-540A. Follow the manufacturers' instructions to use these instruments.
2. A battery-operated AC milliammeter. The Data Precision 245 digital multimeter is suitable for this job.
3. Measuring the voltage drop across a resistor by means of a VOM or battery-operated AC voltmeter. The "limit" indication is 0.75 V, so analog meters must have an accurate low-voltage scale. The Simpson 250 and Sanwa SH-63Trd are examples of a passive VOM that is suitable. Nearly all battery operated digital multimeters that have a 2V AC range are suitable. (See Fig. A)

HOW TO FIND A GOOD EARTH GROUND

A cold-water pipe is guaranteed earth ground; the cover-plate retaining screw on most AC outlet boxes is also at earth ground. If the retaining screw is to be used as your earth-ground, verify that it is at ground by measuring the resistance between it and a coldwater pipe with an ohmmeter. The reading should be zero ohms. If a cold-water pipe is not accessible, connect a 60-100 watts trouble light (not a neon lamp) between the hot side of the receptacle and the retaining screw. Try both slots, if necessary, to locate the hot side of the line, the lamp should light at normal brilliance if the screw is at ground potential. (See Fig. B)

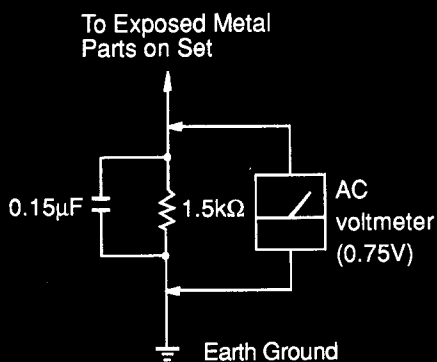

Fig. A. Using an AC voltmeter to check AC leakage.

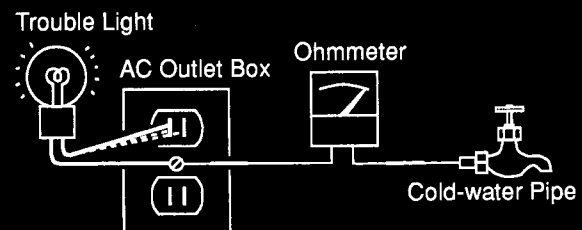

Fig. B. Checking for earth ground.

TABLE OF CONTENTS

<u>Section</u>	<u>Title</u>	<u>Page</u>	<u>Section</u>	<u>Title</u>	<u>Page</u>
1.	GENERAL		4.	SAFETY RELATED ADJUSTMENT	
1-1.	Features	5	4-1.	Safety Related Adjustments	20
1-2.	Location and Function of Parts and Controls	6			
1-3.	Power Sources	9	5.	CIRCUIT ADJUSTMENTS	
2.	DISASSEMBLY		5-1.	D Board Adjustments	22
2-1.	Cabinet Removal	11	5-2.	B Board Adjustments	25
2-2.	B Board Removal	11	5-3.	S Board Adjustments	30
2-3.	Switching Regulator Removal	12	6.	DIAGRAMS	
2-4.	D Board Removal	12	6-1.	Frame Schematic Diagram	31
2-5.	P Board Removal	13	6-2.	Block Diagram (1)	34
2-6.	Rear Assy Removal	13	6-3.	Block Diagram (2)	37
2-7.	HA and FA Boards Removal	14	6-4.	Circuit Boards Location	42
2-8.	Picture Tube Removal	15	6-5.	Printed Wiring Boards and Schematic Diagrams	42
3.	SET-UP ADJUSTMENTS		6-6.	Semiconductors	78
3-1.	Beam Landing	16	7.	EXPLODED VIEWS	
3-2.	Convergence	17	7-1.	Chassis	80
3-3.	Focus	19	7-2.	Picture Tube	81
3-4.	White Balance	19	8.	ELECTRICAL PARTS LIST	82

(CAUTION)

SHORT CIRCUIT THE ANODE OF THE PICTURE TUBE AND THE ANODE CAP TO THE METAL CHASSIS, CRT SHIELD, OR CARBON PAINTED ON THE CRT, AFTER REMOVING THE ANODE.

WARNING!!

AN ISOLATION TRANSFORMER SHOULD BE USED DURING ANY SERVICE TO AVOID POSSIBLE SHOCK HAZARD, BECAUSE OF LIVE CHASSIS.
THE CHASSIS OF THIS RECEIVER IS DIRECTLY CONNECTED TO THE AC POWER LINE.

SAFETY-RELATED COMPONENT WARNING !!

COMPONENTS IDENTIFIED BY SHADING AND MARK Δ ON THE SCHEMATIC DIAGRAMS, EXPLODED VIEWS AND IN THE PARTS LIST ARE CRITICAL TO SAFE OPERATION. REPLACE THESE COMPONENTS WITH SONY PARTS WHOSE PART NUMBERS APPEAR AS SHOWN IN THIS MANUAL OR IN SUPPLEMENTS PUBLISHED BY SONY. CIRCUIT ADJUSTMENTS THAT ARE CRITICAL TO SAFE OPERATION ARE IDENTIFIED IN THIS MANUAL. FOLLOW THESE PROCEDURES WHENEVER CRITICAL COMPONENTS ARE REPLACED OR IMPROPER OPERATION IS SUSPECTED.

(ATTENTION)

APRES AVOIR DECONNECTE LE CAP DE L'ANODE, COURT-CIRCUITER L'ANODE DU TUBE CATHODIQUE ET CELUI DE L'ANODE DU CAP AU CHASSIS METALLIQUE DE L'APPAREIL, OU AU COUCHE DE CARBONE PEINTE SUR LE TUBE CATHODIQUE OU AU BLINDAGE DU TUBE CATHODIQUE.

ATTENTION!!

AFIN D'EVITER TOUT RISQUE D'ELECTROCUTION PROVENANT D'UN CHÂSSIS SOUS TENSION, UN TRANSFORMATEUR D'ISOLEMENT DOIT ETRE UTILISÉ LORS DE TOUT DÉPANNAGE. LE CHÂSSIS DE CE RÉCEPTEUR EST DIRECTEMENT RACCORDÉ À L'ALIMENTATION SECTEUR.

ATTENTION AUX COMPOSANTS RELATIFS À LA SÉCURITÉ!!

LES COMPOSANTS IDENTIFIÉS PAR UNE TRAME ET PAR UNE MAPQUE Δ SUR LES SCHÉMAS DE PRINCIPE, LES VUES EXPLOSÉES ET LES LISTES DE PIÈCES CONT D'UNE IMPORTANCE CRITIQUE POUR LA SÉCURITÉ DU FONCTIONNEMENT. NE LES REMPLACER QUE PAR DES COMPOSANTS SONY DONT LE NUMÉRO DE PIÈCE EST INDIQUÉ DANS LE PRÉSENT MANUEL OU DANS DES SUPPLÉMENTS PUBLIÉS PAR SONY. LES RÉGLAGES DE CIRCUIT DONT L'IMPORTANCE EST CRITIQUE POUR LA SÉCURITÉ DU FONCTIONNEMENT SONT IDENTIFIÉS DANS LE PRÉSENT MANUEL. SUIVRE CES PROCÉDURES LORS DE CHAQUE REMPLACEMENT DE COMPOSANTS CRITIQUES, OU LORSQU'UN MAUVAIS FONCTIONNEMENT EST SUSPECTÉ.

SECTION 1 GENERAL

1-1. FEATURES

Four color systems available

The monitor can display PAL, SECAM, NTSC_{3.58} and NTSC_{4.43}* signals. The appropriate color system is selected automatically.

* A signal of NTSC_{4.43} is used for playing back NTSC recorded video cassettes with a video tape recorder/player especially designed for use with this system.

Super Fine Pitch Trinitron picture tube

(PVM-8044Q only)

The Super Fine Pitch Trinitron picture tube provides a high resolution picture. Horizontal resolution is more than 450 TV lines at the center of the picture.

Blue only picture

The picture can be displayed in blue and black only. This facilitates hue adjustment and the observation of video noise.

Analog RGB/component input connectors

Analog RGB or component (Y, R-Y and B-Y) signals from video equipment can be input through these connectors.

Y/C input connector

The video signal, split into the chrominance signal (C) and the luminance signal (Y), can be input through this connector, eliminating the interference between the two signals, which tends to occur in a composite video signal, assuring video quality.

Beam current feedback circuit

The built-in beam current feedback circuit assures stable white balance.

Comb filter

When NTSC video signals are received, a comb filter activates to increase the resolution, resulting in fine picture detail without color spill or color noise.

Automatic termination

The Y/C, VIDEO IN and EXT SYNC IN connectors are terminated at 75 ohms inside, when no cable is connected to the loop-through output connectors. When a cable is connected to an output connector, the 75-ohm termination is automatically released.

EIA standard 19-inch rack mounting

By using an MB-507 mounting bracket (not supplied), the monitor can be mounted in an EIA standard 19-inch rack. For details on mounting, see the instruction manual of the MB-507.

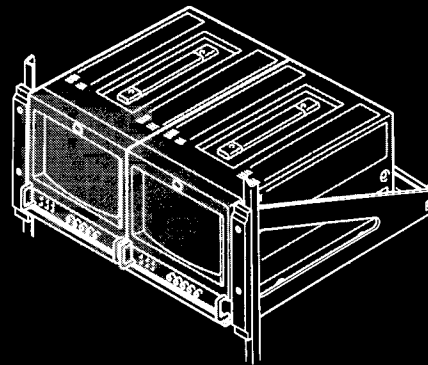

For the Customers in the USA

INFORMATION

This equipment has been tested and found to comply with the limits for a Class A digital device, pursuant to Part 15 of the FCC Rules. These limits are designed to provide reasonable protection against harmful interference when the equipment is operated in a commercial environment. This equipment generates, uses, and can radiate radio frequency energy and, if not installed and used in accordance with the instruction manual, may cause harmful interference to radio communications. Operation of this equipment in a residential area is likely to cause harmful interference in which case the user will be required to correct the interference at his own expense.

You are cautioned that any changes or modifications not expressly approved in this manual could void your authority to operate this equipment.

For the Customers in Canada

This apparatus complies with the Class A limits for radio noise emissions set out in Radio Interference Regulations.

1-2. LOCATION AND FUNCTION OF PARTS AND CONTROLS

Front

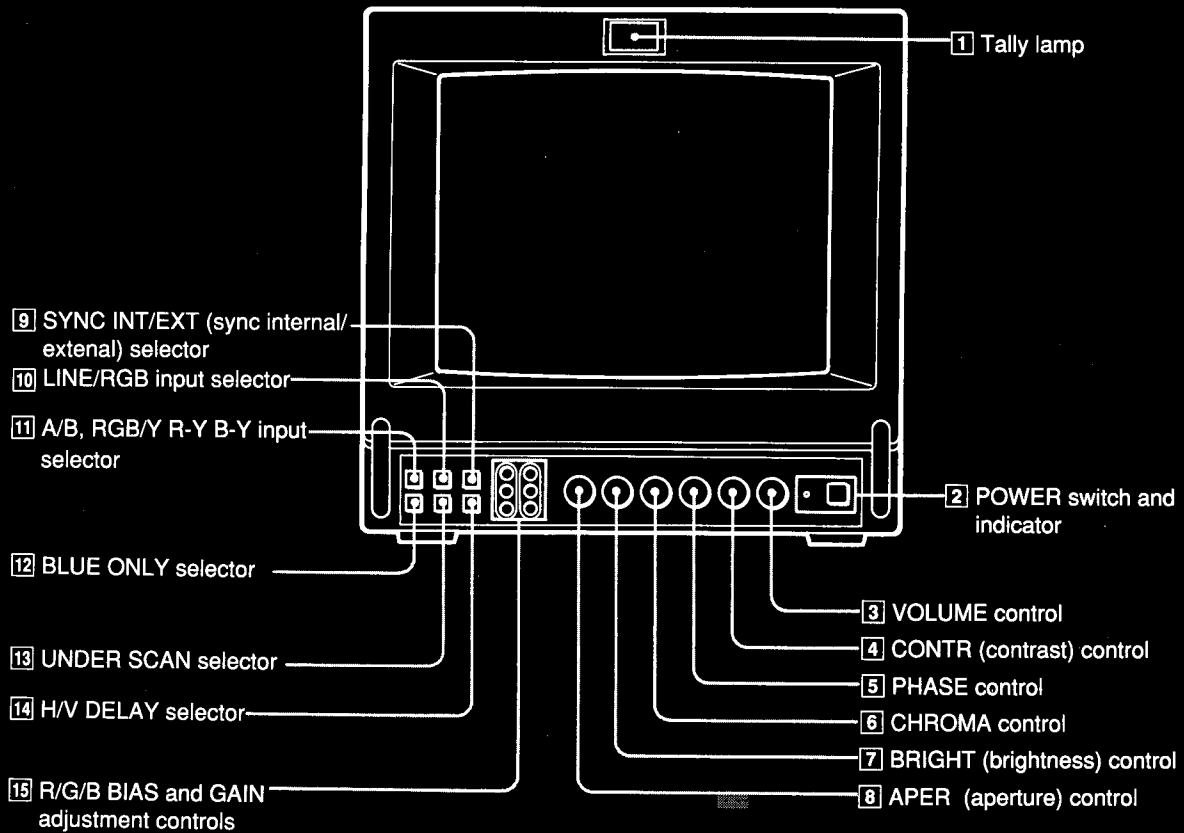
**1 Tally lamp****2 POWER switch and indicator**

Depress to turn the monitor on. The indicator will light up in green. The POWER indicator also functions as the battery indicator. When the internal battery becomes weak or the power supplied through the DC12V IN jack decreases, the indicator flashes.

3 VOLUME control

Turn this control clockwise or counterclockwise to obtain the desired volume.

4 CONTR (contrast) control

Turn clockwise to make the contrast stronger and counterclockwise to make it weaker.

5 PHASE control

This control is effective only for the NTSC_{3.58} and NTSC_{4.43} color systems. Turn clockwise to make the skin tones greenish and counterclockwise to make them purplish.

Notes

- The PHASE, CHROMA and APER control settings have no effect on an analog RGB signal.
- The PHASE control has no effect on component signals.
- The PHASE control setting is effective only for the NTSC system.

6 CHROMA control

Turn clockwise to make the color intensity stronger and counterclockwise to make it weaker.

7 BRIGHT (brightness) control

Turn clockwise for more brightness and counterclockwise for less.

8 APER (aperture) control

Turn clockwise for more sharpness and counterclockwise for less.

9 SYNC INT/EXT (sync internal/external) selector

Keep this button released (INT) to operate the monitor on the sync signal from the displayed composite video signal. Depress this button (EXT) to operate the monitor on an external sync signal fed through the EXT SYNC connector on the rear panel.

10 LINE/RGB input selector

Select the program to be monitored. Keep this button released (LINE) for a signal fed through the LINE A or LINE B connectors. Depress this button (RGB) for a signal fed through the RGB connectors.

11 A/B, RGB/Y R-Y B-Y input selector

When the LINE/RGB input selector is set to LINE, keep this button released (A) for a signal fed through the LINE A connectors. Depress this button (B) for a signal fed through the LINE B connectors.

When the LINE/RGB input selector is set to RGB, select the RGB signal or the component signal which is fed through the RGB input connectors. Keep this button released (RGB) for the RGB signal. Depress this button (Y R-Y B-Y) for the component signal.

12 BLUE ONLY selector

Depress this button to turn off the red and green signals. A blue signal is displayed as an apparent monochrome picture on the screen. This facilitates "chroma" and "phase" control adjustments and the observation of video noise.

13 UNDER SCAN selector

Depress this button for underscanning. The display size is reduced by approximately 3% so that four corners of the raster are visible.

14 H/V DELAY selector

Depress this button to observe the horizontal and vertical sync signals at the same time. The horizontal sync signal is displayed in the left quarter of the screen; the vertical sync signal is displayed near the center of the screen.

15 R/G/B BIAS and GAIN adjustment controls

Used for white balance fine adjustment. BIAS and GAIN controls are provided for the R (red), G (green) and B (blue) screens.

BIAS: Adjust the white balance and brightness of the screen at the lowlight.

GAIN: Adjust the white balance and brightness of the screen at the highlight.

Rear

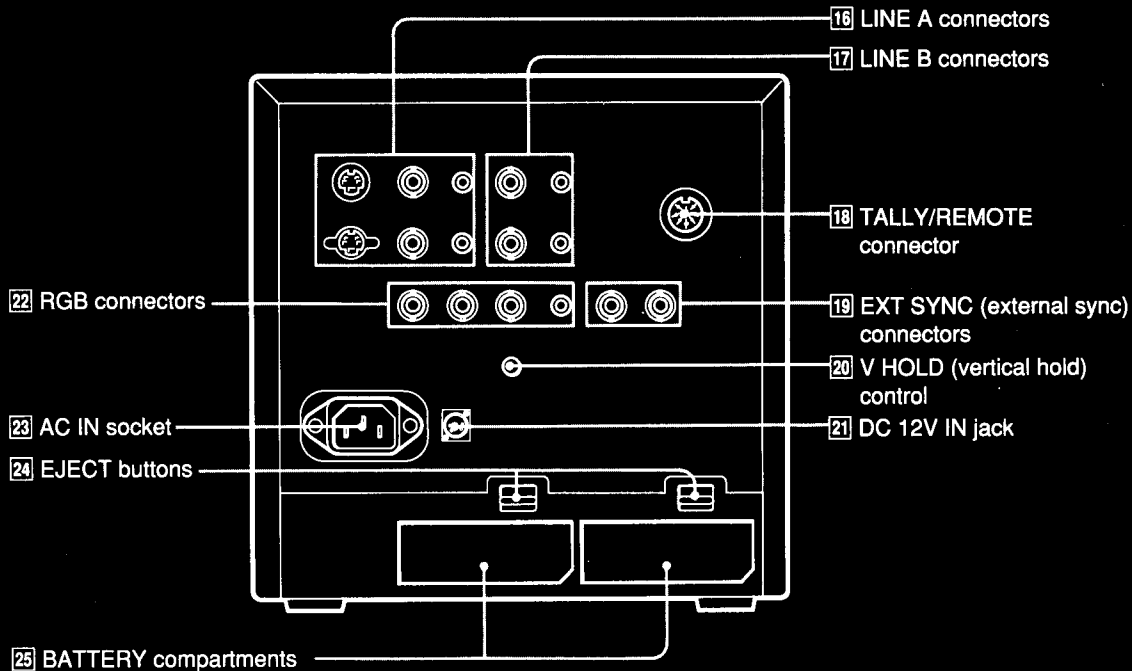

16 LINE A connectors

To monitor the signal fed through these connectors, keep the LINE/RGB selector and the A/B, RGB/Y R-Y B-Y selector on the front panel released (LINE and A).

Note

The Y/C IN connector has a priority over the VIDEO IN connector.

When a plug is connected to the Y/C IN connector, the VIDEO IN connector is automatically disconnected.

17 LINE B connectors

To monitor the signal fed through these connectors, keep the LINE/RGB selector released (LINE) and depress the A/B, RGB/Y R-Y B-Y selector (B) on the front panel.

VIDEO IN (BNC): Connect to the video output of a video camera, VCR or other video equipment.

VIDEO OUT (BNC): Loop-through output of the VIDEO IN connector. Connect to the video input of a VCR or another monitor.

AUDIO IN (phono jack): Connect to the audio output of a VCR or a microphone (through a suitable microphone amplifier).

AUDIO OUT (phono jack): Loop-through output of the AUDIO IN connector. Connect to the audio input of a VCR or another monitor.

18 TALLY/REMOTE connector (8-pin mini DIN)

Connect to the tally output of a control console, special-effect generator, etc. The tally lamp on the front panel will be turned on and off by the connected equipment. This connector can be used for connecting a remote controller. For the pin assignment of this connector, see "Specifications" on page 2.

19 EXT SYNC (external sync) connectors

IN (BNC): When this monitor operates on an external sync signal, connect the reference signal from a sync generator to this connector. In this case, depress the SYNC INT/EXT selector (EXT) on the front panel.

OUT (BNC): Loop-through output of the EXT SYNC IN connector. Connect to the external sync input of video equipment to be synchronized with this monitor.

20 V HOLD (vertical hold) control

Turn to stabilize the picture if it rolls vertically.

21 DC 12V IN jack (XLR, 4 pin)

Connect the Sony AC-500 AC power adaptor (not supplied).

22 RGB/component input connectors**R/R-Y, G/Y, B/B-Y (BNC), AUDIO (phono):**

To monitor a signal fed through these connectors, depress the LINE/RGB selector on the front panel (RGB). When the SYNC INT/EXT selector on the front panel is released (INT), the monitor operates on the sync signal from the G/Y channel.

To monitor the analog RGB signal

Connect to the analog RGB signal outputs of a video camera having no sync signal. Keep the A/B, RGB/Y R-Y B-Y selector on the front panel released (RGB).

To monitor the component signal

Connect to the R-Y/Y/B-Y component signal outputs of a Sony BetaCam video camera. Depress the A/B, RGB/Y R-Y B-Y selector on the front panel (Y R-Y B-Y).

23 AC IN socket

Connect the supplied AC power cord to this socket and to a wall outlet.

24 EJECT buttons

Press the EJECT button upwards to remove the battery pack.

25 BATTERY compartments

Insert the NP-1A/1B battery pack (not supplied).

1-3. POWER SOURCES**House Current**

Connect the supplied AC power cord to the AC IN socket and to a wall outlet.

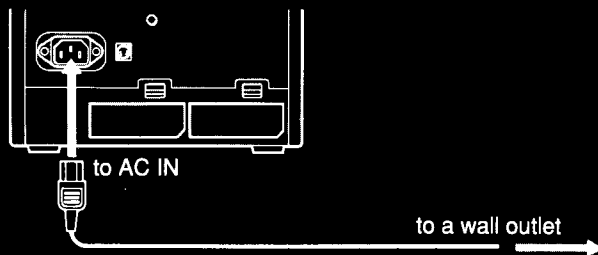

When the AC power cord is plugged into the AC IN socket, the battery pack (if installed) or the AC power adaptor (if connected) is automatically disconnected.

Rechargeable Battery

The monitor can operate with one or two battery packs. For extended use, two battery packs are recommended.

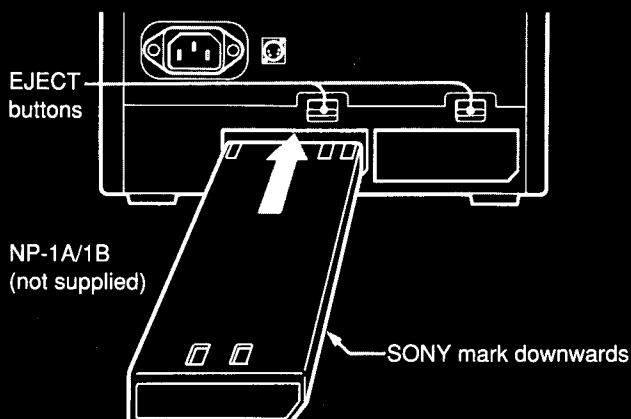

To remove the battery pack, press the EJECT button upwards.

For charging, use the BC-1WA battery charger (not supplied) for the NP-1A or the BC-1WB for the NP-1B.

Note

Make sure that the AC power cord and the AC power adaptor are disconnected from the monitor. Otherwise, the monitor cannot operate on the battery pack(s).

MEMO

SECTION 2 DISASSEMBLY

2-1. CABINET REMOVAL

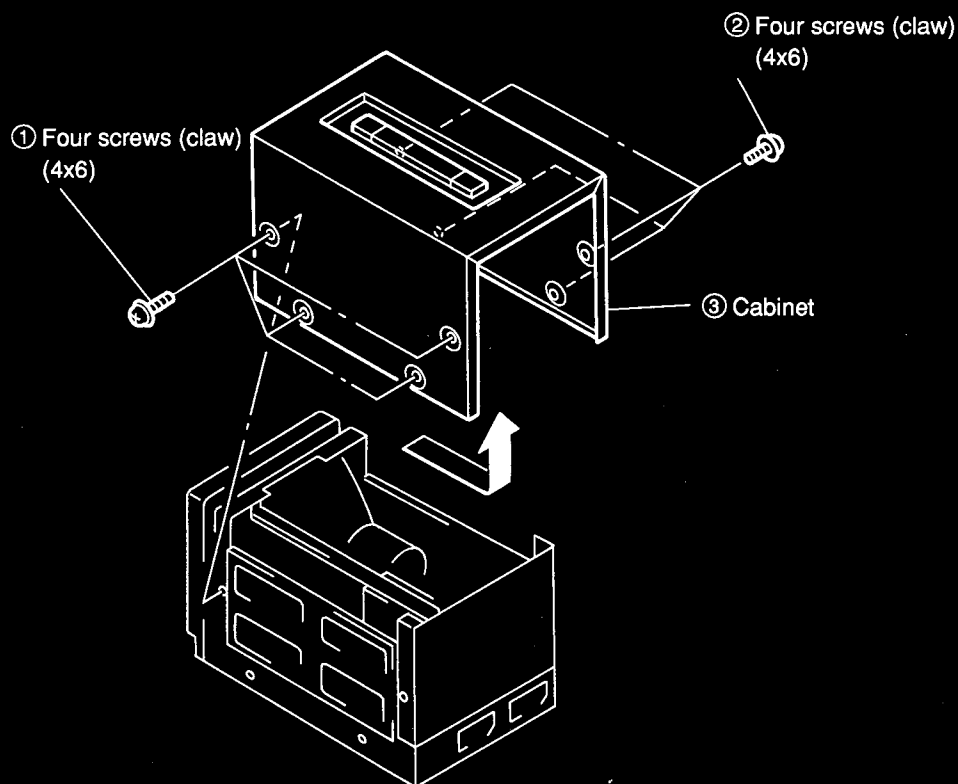

2-2. B BOARD REMOVAL

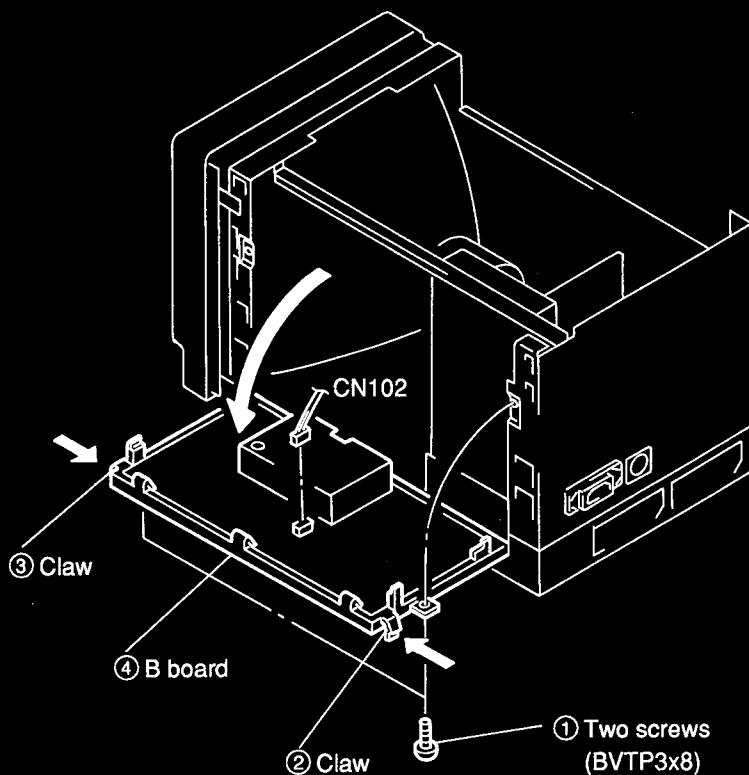

2-3. SWITCHING REGULATOR REMOVAL

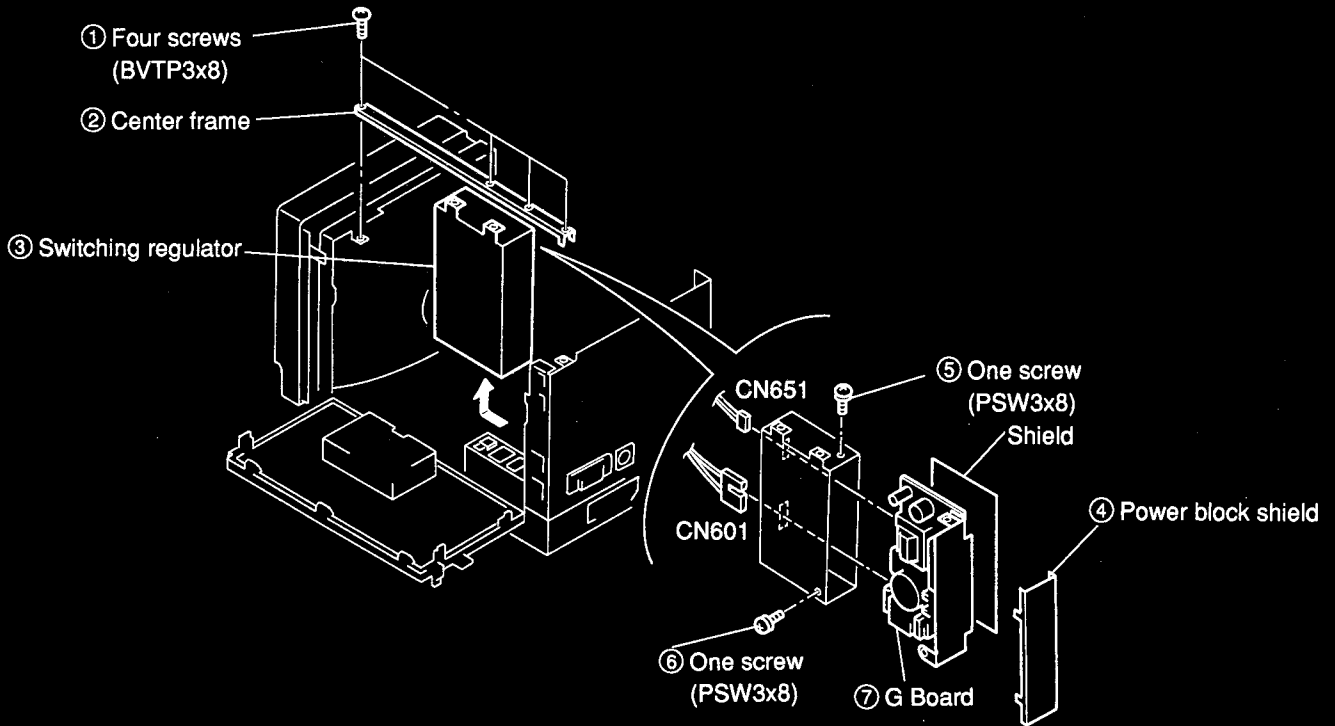

2-4. D BOARD REMOVAL

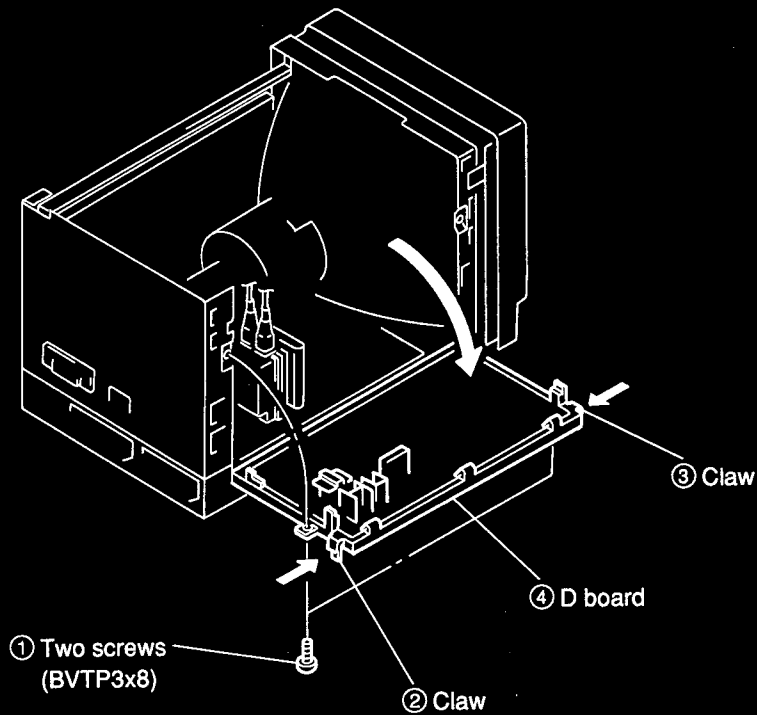

2-5. P BOARD REMOVAL

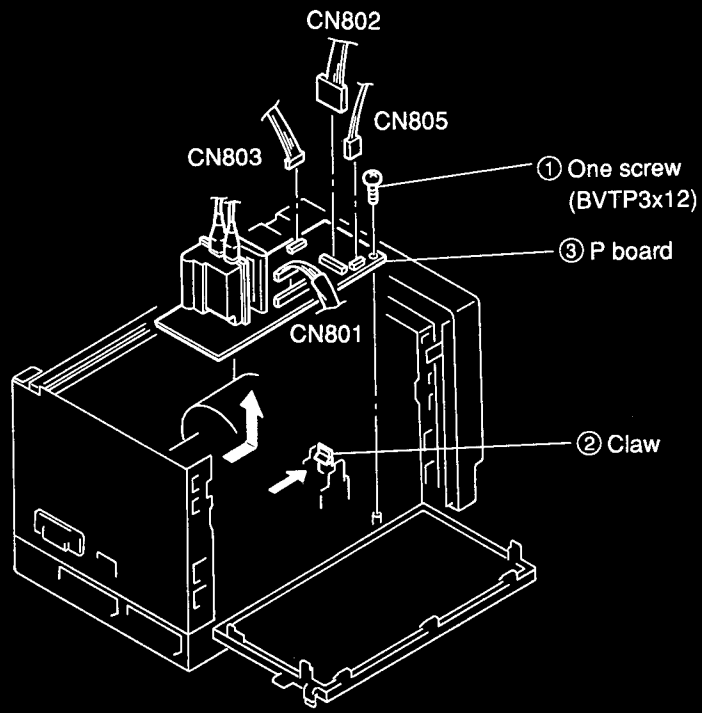

2-6. REAR ASSY REMOVAL

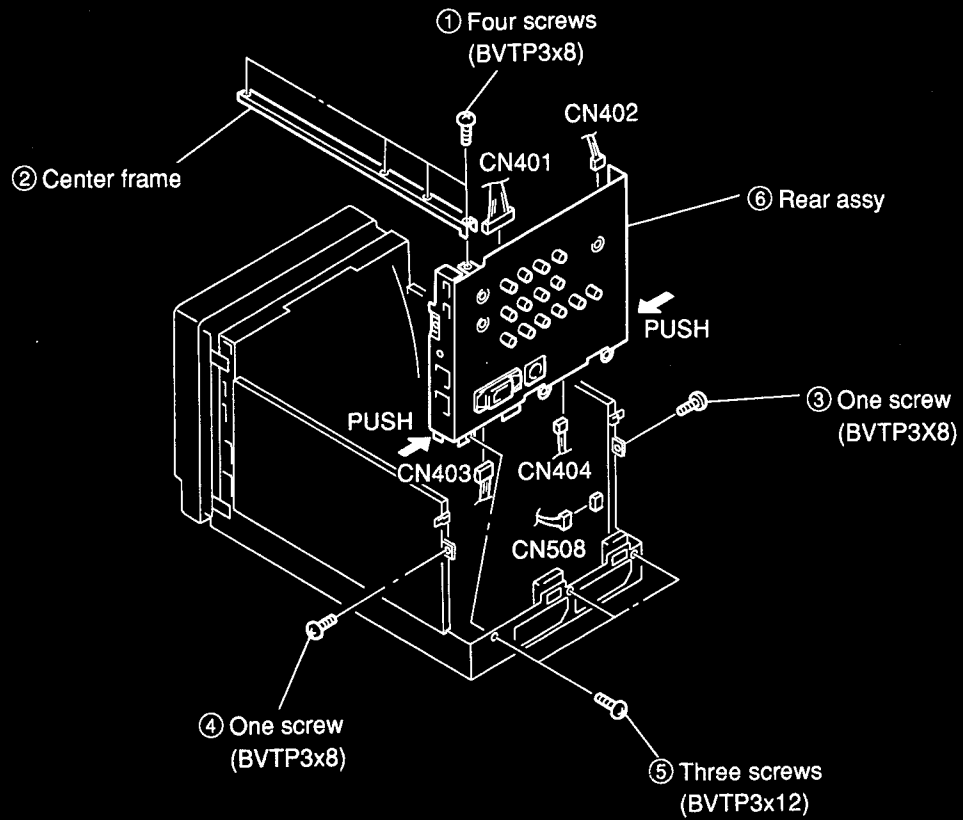

2-7. HA AND FA BOARDS REMOVAL

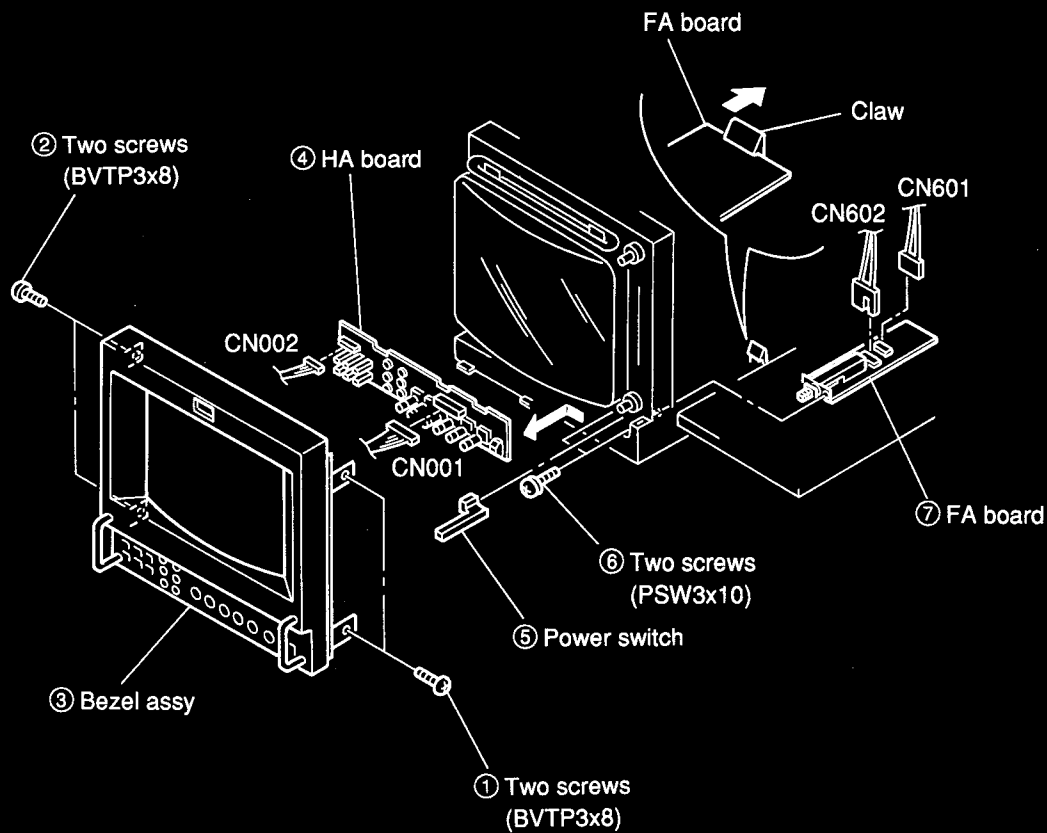

2-8. PICTURE TUBE REMOVAL

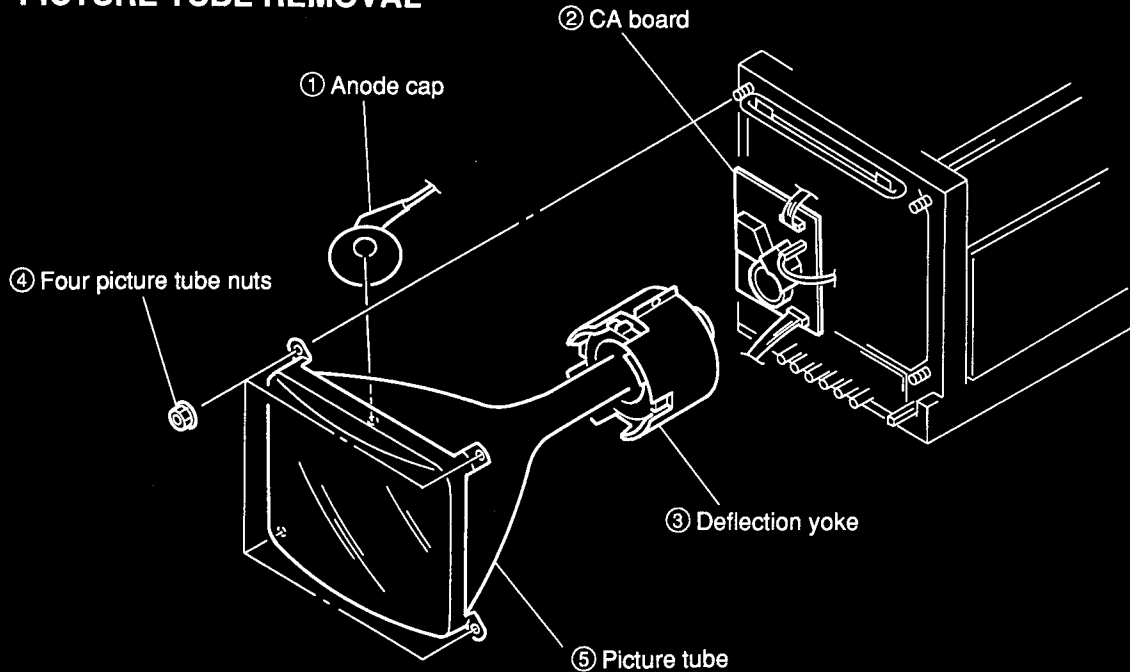

Note : Caution for ANODE CAP installation.

When you replace PICTURE TUBE or FBT, remove RTV on ANODE CAP so that PICTURE TUBE and FBT can be separated. Please adhere picture tube and anode cap in accordance with the following procedure.

ADHERING PROCEDURE OF ANODE CAP.

1. Clean PICTURE TUBE ANODE CAP with ethnaol to remove original RTV.
2. Dry clean face with air.

3. Use KE-490RTV (RTV silicone adhesive, SHIN-ETSU CHEMICAL).

Part. No.	Description
7-322-065-19	Silicone (RTV) KE-490W

4. Install ANODE CAP.
5. Adequately apply RTV to the entire picture tube anode area, piece the anode cap onto the picture tube and push it down security so that no air pockets remain beneath the cap.
6. Dry more than 12 hours at room temperature.

• **REMOVAL OF ANODE-CAP REMOVING PROCEDURES**

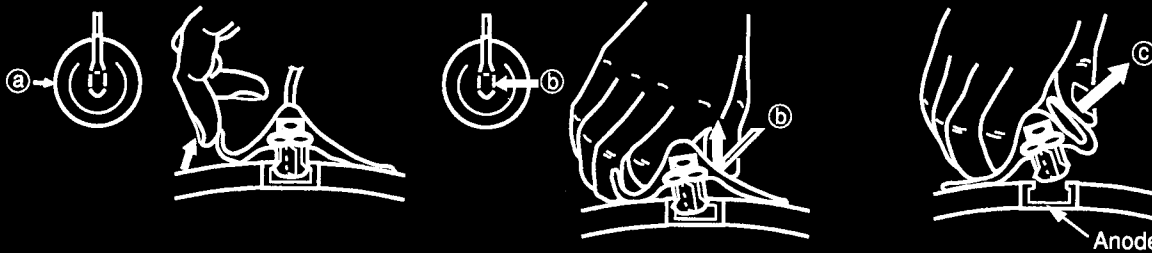

- ① Turn up one side of the rubber cap in the direction indicated by the arrow ③.
- ② Using a thumb pull up the rubber cap firmly in the direction indicated by the arrow ⑥.
- ③ When one side of the rubber cap is separated from the anode button, the anode-cap can be removed by turning up the rubber cap and pulling up it in the direction of the arrow ③.

• **HOW TO HANDLE AN ANODE-CAP**

- ① Don't hurt the surface of anode-caps with sharp shaped material!
- ② Don't press the rubber hardly not to hurt inside of anode-caps!
A metal fitting called as shatter-hook terminal is built in the rubber.
- ③ Don't turn the foot of rubber over hardly!

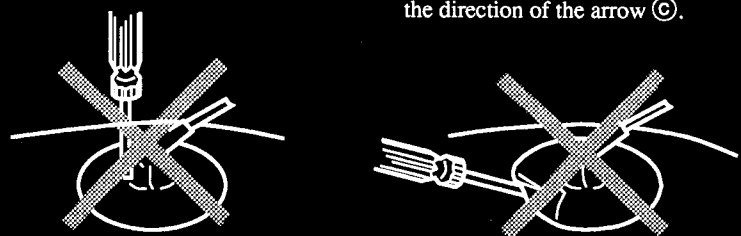

SECTION 3 SET-UP ADJUSTMENTS

- The following adjustments should be made when a complete realignment is required or a new picture tube is installed.
- These adjustments should be performed with rated power supply voltage unless otherwise noted.

The control and switch below should be set as follows unless otherwise noted:

CONTRAST control 80%
 BRIGHTNESS control 50%

Perform the adjustments in order as follows:

- 3-1. Beam Landing
- 3-2. Convergence
- 3-3. Focus
- 3-4. White Balance

Note: Test equipment Required.

1. Color Bar/Pattern Generator
2. Degausser
3. Color Analyzer (Minolta)
4. Luminance Level Meter

3-1. BEAM LANDING

Precaution

1. Set the side of the unit with the PICTURE TUBE so that it faces east or west in order to reduce the influence of external magnetic force.
2. Turn the power switch for the unit ON and erase the magnetic force using a degausser.

(1) Beam Landing

1. Receive an entirely white signal with the pattern generator.
 CONTRAST MAX.
 BRIGHTNESS set easy to observe
2. Adjust the white balance, G2 voltage and convergence roughly.
3. Loosen the deflection yoke mounting screw, and set the purity control to the center as shown in Fig.3-1.
4. Switch over the pattern generator to green.
5. Move the deflection yoke backward, and adjust with the purity control so that green is in the center and blue and red are at the sides, evenly. (Fig.3-2)
6. Move the deflection yoke forward, and adjust so that the entire screen becomes green. Repeat 5 to 7 as to red and blue.
7. When landing at the corners is not right, correct by using the magnet. (Fig.3-3)
8. When the position of the deflection yoke is determined, tighten it with a deflection yoke mounting screw.

CAUTION: When correction magnet is used, be sure to degauss the unit.

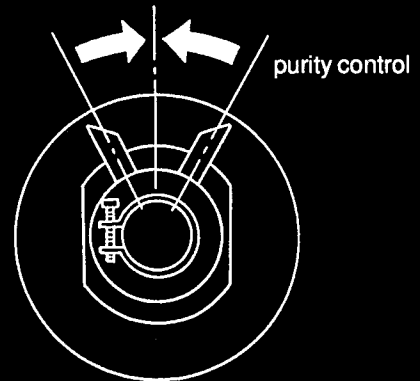

Fig.3-1



Fig.3-2

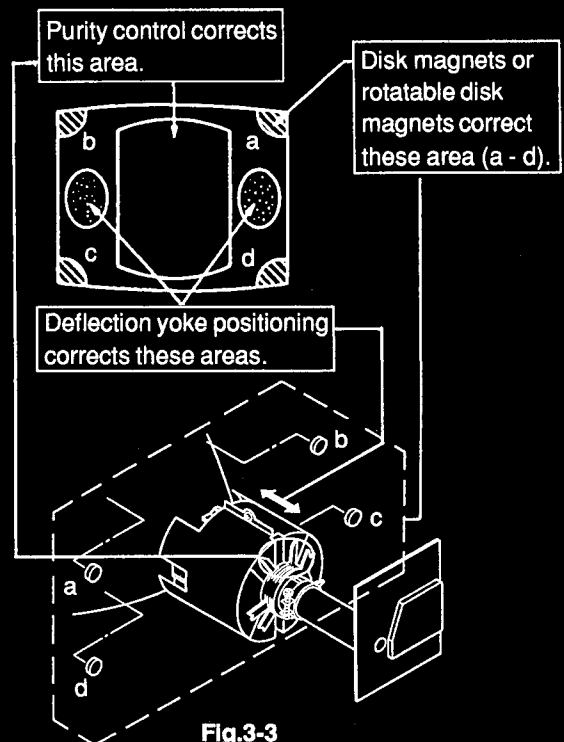
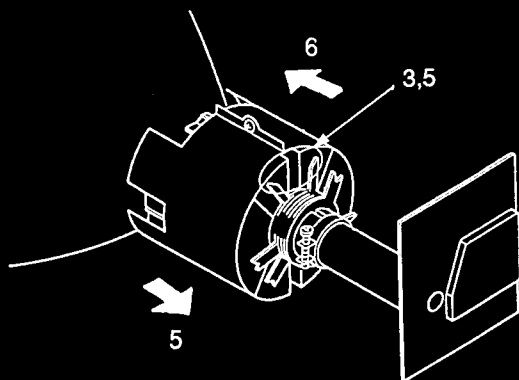

Fig.3-3

3-2. CONVERGENCE

(1) Horizontal and vertical Static Convergence Adjustment on the Center of Screen.

- Before starting, perform V. SIZE, V. CENT, H.SIZE, H.CENT and Screen Distortion Adjustment rightly.

(Static Convergence Adjustment)

1. Receive a dot signal, setting BRIGHTNESS minimum and set CONTRAST to normal.
2. Adjust H.STAT VR to coincide red, green and blue dots on the center of screen. (Horizontal movement)
3. Adjust V.STAT magnet to coincide red, green and blue dots on the center of screen. (Vertical movement)

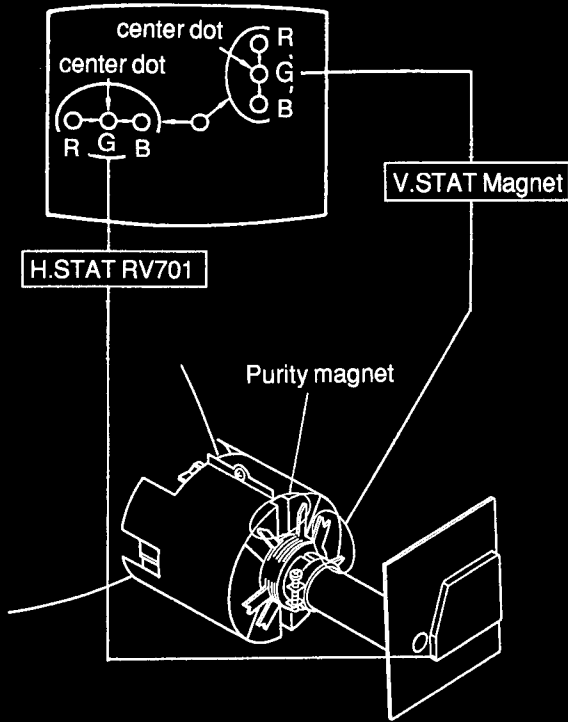

* If the red, green and blue dots do not coincide on the center of screen with H.STAT VR, perform adjustment using V.STAT at the same time while tracking.
(Tilt the V.STAT magnet and adjust static convergence to open or close the V.STAT magnet.)

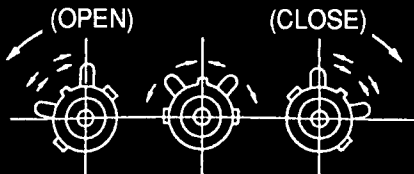

4. When the V.STAT magnet is moved in the direction of arrow A and b, red, green and blue dots move as shown below.

① When moving the V.STAT Magnet open or close.

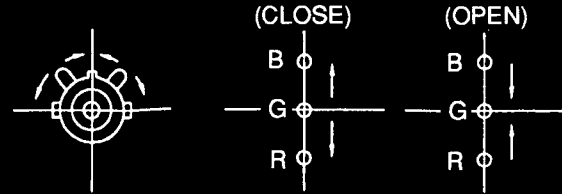

② When moving the V.STAT magnet counterclockwise.

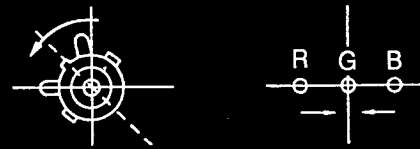

③ When moving the V.STAT magnet clockwise.



④ When tilt the V.STAT magnet and open or close.

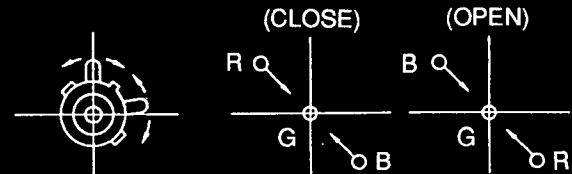

* If the red and green dots do not coincide with blue dot, adjustment with BMC (6-poles) magnet.

5. HMC and VMC correction for BMC (6-Poles) magnet.

① HMC (Horizontal Misconvergence) correction and motion of the Electron Beam with the BMC (6-poles) magnet.

HMC Correction

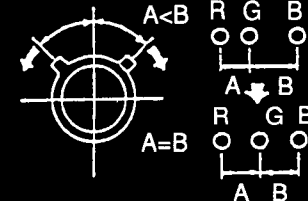

HMC Correction

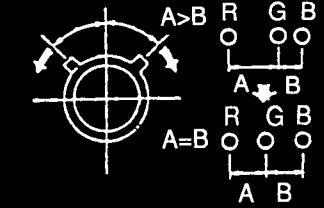

② VMC (Vertical Misconvergence) correction and motion of the Electron Beam with the BMC (6-poles) magnet.

VMC Correction (A)



VMC Correction (B)

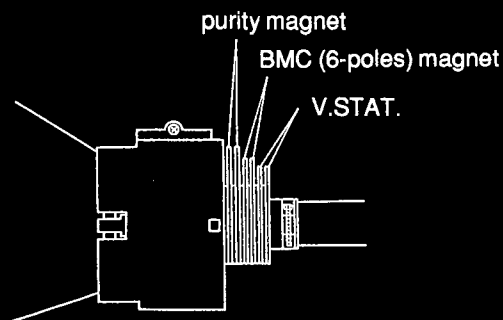
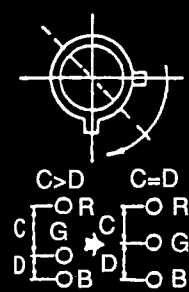

(2) Horizontal and Vertical Dynamic Convergence Adjustment at the Environs of the Screen (Dynamic Convergence Adjustment)

1. When there is misconvergence at the sides of screen, adjust for best convergence as follows by moving the deflection yoke.
2. Loosen deflection yoke screw. Remove deflection yoke spacers. Move the deflection yoke for best convergence. Tighten the deflection yoke screw. Install three deflection yoke spacers.

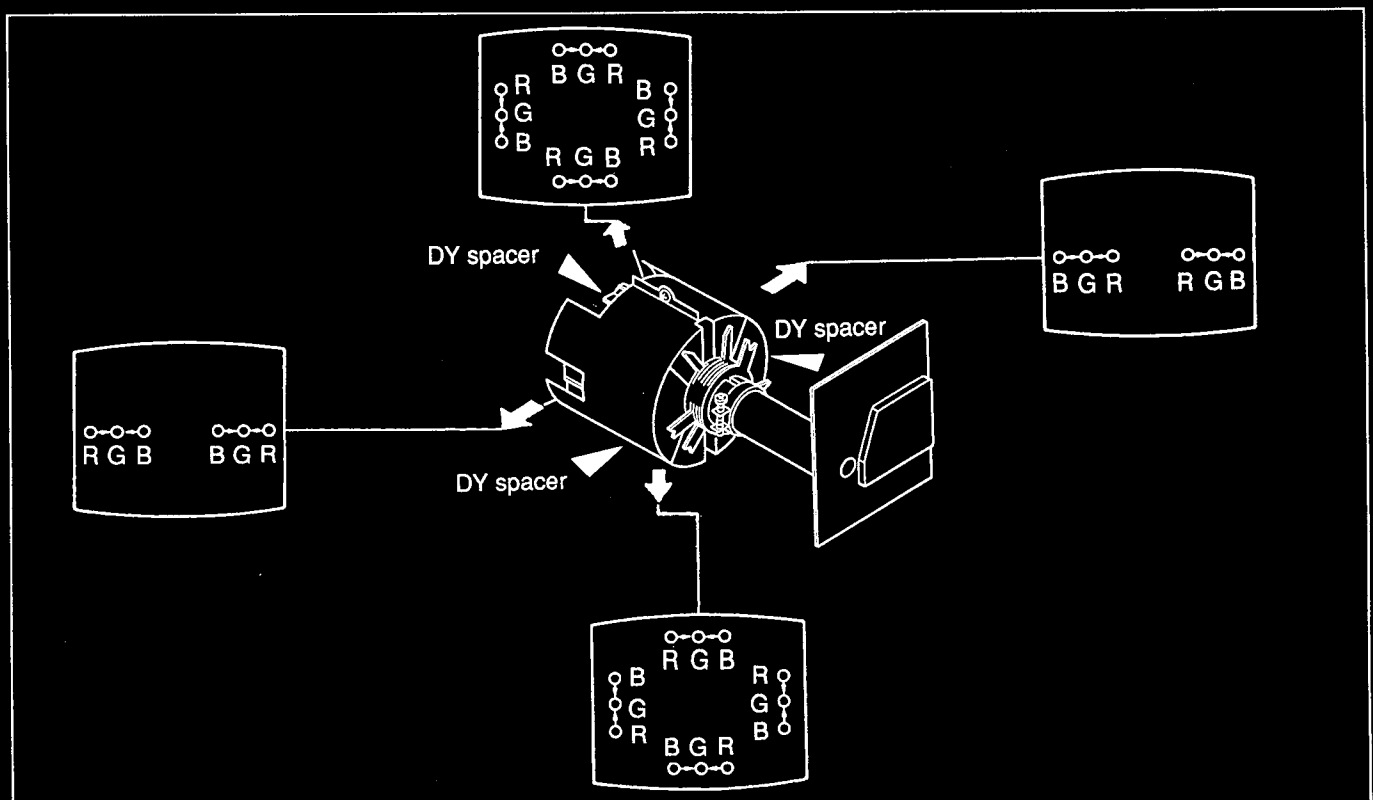

Screen-corner Convergence

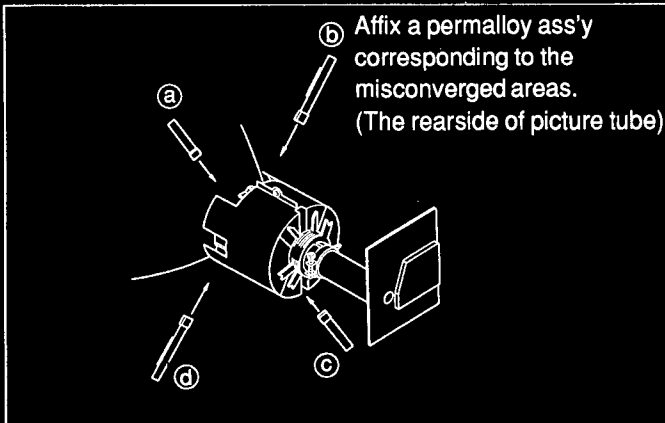
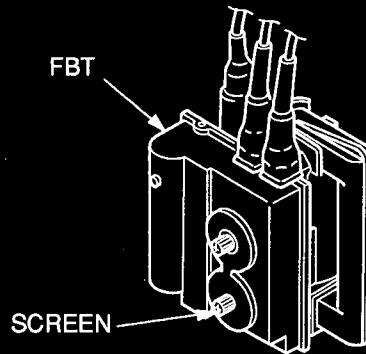
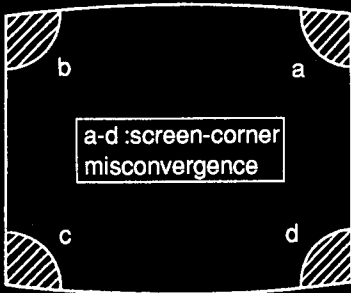

[White Balance]

1. Receive a color-bar pattern signal with the pattern generator. (Make black and white screen by chroma switch off.)
2.
 - BRIGHTNESS 50%
 - CONTRAST Minimum
 - CHROMA 50%
 - DRIVE control Mechanical center
 - BKG control Mechanical center
3. Adjust RV118 (SUB BRT) on B board so that the blue stripe portion on the color-bar pattern signal is bright dimly.

color-bar pattern

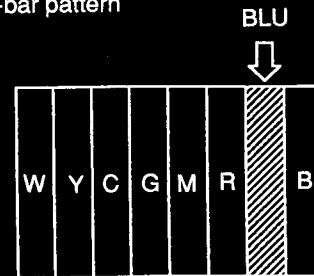

3-3. FOCUS

1. Receive the broadcast.
2. CONTRAST → Normal
3. Adjust FOCUS control so that the focus on the center of screen becomes to the best.

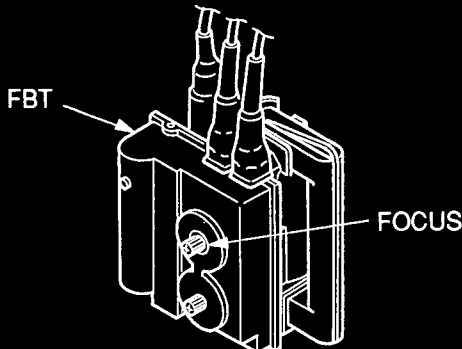

3-4. WHITE BALANCE

[Screen (G2) Voltage Adjustment]

1. Receive a dot signal with the pattern generator.
2. Adjust R. G. B cut-off controls so that respective cathode voltage against ground becomes 103V DC.
3. Observing the screen, adjust SCREEN control so that the background of the dot signal is bright dimly.

4. Receive an entirely white signal from the pattern generator.
5. CONTRAST 70% (90 degree clockwise from mechanical center.)
6. Using the luminance level meter, adjust the luminance level of the pattern generator becomes 3 Nits. (The condition the screen is bright dimly.)
7. Adjust white balance at cut-off using RV119 (G-C/O) and RV121 (B-C/O).
8. Change the all-white signal luminance level to 100 IREs.
9. Adjust white balance at high-light using RV120 (G-GAIN) and RV121 (B-GAIN).
10. Change the unit to blue ONLY mode.
11. Adjust white balance (at high-light) in blue ONLY mode using RV124 *R-GAIN/BL) and RV125 (G-GAIN/BL).
12. Using the luminance level meter, adjust the luminance level of the pattern generator becomes 8 Nits. Confirm that white balance at cut-off is satisfactory..

SECTION 4 SAFETY RELATED ADJUSTMENT

4-1. SAFETY RELATED ADJUSTMENTS

B+ MAX CONFIRMATION (RV651)

The following adjustments should always be performed when replacing the following components (marked with on the schematic diagram).

on G board : (Power supply block)

IC601, IC651, PH602, C655, R653, R655, R656, R657, RV651.

1. For US model, supply $130V_{-0}^{+0.5}$ V AC with variable auto-transformer.
2. Receive a dot signal.
3. • CONTRAST Minimum
• BRIGHTNESS Minimum
4. Connect a digital multimeter to RY1601 pin-⑦ of D board.
5. Turn RV651 on the G board fully clockwise. Confirm that the voltage of RY1601 pin-⑦ is less than 41.9V DC.
6. If step 5 is not satisfied, readjust the RV651. After adjusting, fasten RV651 in place with epoxy.

B+ MAX IN DC POWER INPUT MODE, CONFIRMATION (RV1603)

The following adjustments should always be performed when replacing the following components (marked with on the schematic diagram).

on D board :

Q1601, Q1602, Q1603, D1601, D1602, D1603, D1604, D1605, C1601, C1602, R1601, R1602, R1603, R1604, R1605, R1606, R1607, R1608, R1629, R1628, R1630, RV1601, RV1603.

1. Supply DC $12V_{-0}^{+0.4}$ V from DC 12V IN connector.
2. Receive a dot signal.
3. • CONTRAST Minimum
• BRIGHTNESS Minimum
4. Connect a digital multimeter to C1605 positive + side of D board.
5. Turn RV1601 on the D board fully clockwise. Confirm that the voltage of C1605 + pin is less than 41.9V DC.
6. If step 5 is not satisfied, readjust the RV1603. After adjusting, fasten RV1603 in place with epoxy.

HOLD-DOWN CIRCUIT CONFIRMATION (RV833) AND READJUSTMENTS

The following adjustments should always be performed when replacing the following components (marked with on the schematic diagram).

on D board:

IC502, Q833, Q834, Q835, Q836, D835, D836, C519, C814, C843, C844, C845, C846, C847, C848, RV833, R523, R850, R851, R852, R853, R854, R855, R856, R857, R858, R859, R861, R862, R863, NL801.

on P board: NL801, T802 (FBT)

1. Receive an entire white signal.
2. • CONTRAST Maximum
• BRIGHTNESS Maximum
3. Connect a digital multimeter to the TP85 (CN503 pin-⑥).
4. Confirm the voltage is $14.1 \pm 3.0V$ DC.
5. Receive a dot signal.
6. Connect an ammeter between D board CN503 pin-⑧ and P board CN801 pin-⑧.
7. Adjust BRIGHTNESS and CONTRAST so that the current is $IABL = 160 \pm 30 \mu A$.
8. Apply an external DC voltage gradually to TP85. When the voltage becomes $18.5V \pm 0.1V$ DC, confirm the HOLD-DOWN circuit operates immediately and raster disappears.
9. When external DC voltage at TP85 becomes $17.5V \pm 0.1V$ DC, confirm the HOLD-DOWN circuit doesn't operate.
10. Receive an entire white signal.
11. Adjust with BRIGHTNESS and CONTRAST controls so that the current is $IABL = 520 \pm 30 \mu A$.
12. Apply DC voltage of $17.8V \pm 0.1V$ to TP85. Confirm the HOLD-DOWN circuit operates immediately and raster disappears.
13. With the same set-up as steps 10 and 11, supply $16.8V \pm 0.1V$ DC to TP85. Confirm that the HOLD-DOWN circuit doesn't operate.
14. When above specifications are not satisfied, readjust RV833. After adjusting, fasten RV833 in place with epoxy.

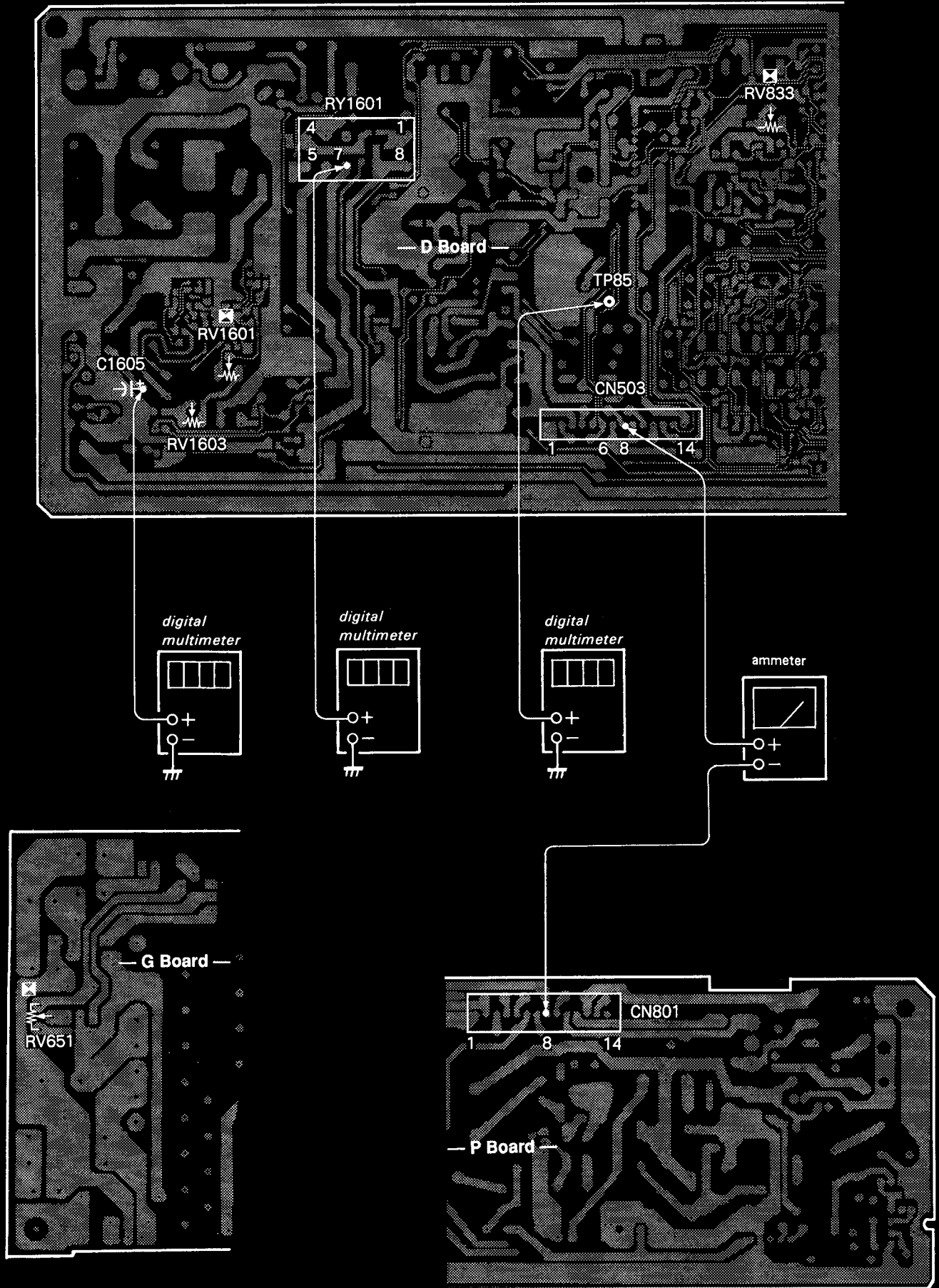

SECTION 5 CIRCUIT ADJUSTMENTS

5-1. D BOARD ADJUSTMENTS

—D BOARD (COMPONENT SIDE)—

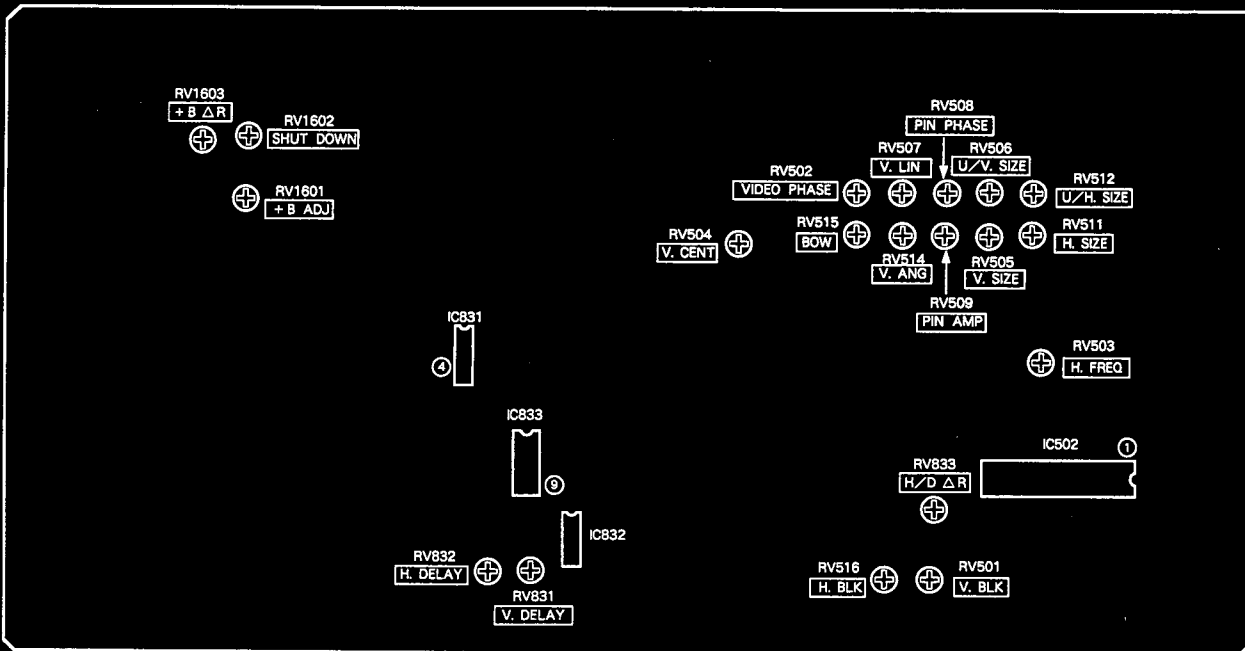

HORIZONTAL OSCILLATION FREQUENCY ADJUSTMENT (RV503)

1. Receive a monoscope signal.
2. Connect pin-① of IC502 to ground with 100 μ F/16V electrolytic capacitor.
3. Adjust RV503 (H.FREQ) so that the screen streaming to stops.



SCREEN PHASE ADJUSTMENTS (RV502, RV512, RV516)

1. Receive a monoscope signal.
2. Set U/S (Under Scan) switch to Under mode.
3.
 - CONTRAST Minimum
 - BRIGHTNESS Maximum.
4. Adjust RV512 (U/H. SIZE) so that the white frame of monoscope signal becomes visible.
5. Adjust RV516 (H. BLK) for minimum BLKG width so that all the deflection area becomes visible.
6. Adjust RV502 (VIDEO PHASE) so that the monoscope's white frames should have equal width.

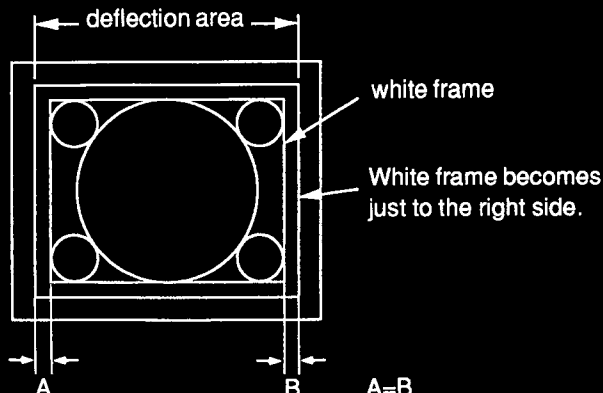

H.V BLK ADJUSTMENTS (RV501, RV516)

1. Receive a monoscope signal.
2. Set U/S (Under Scan) switch to Under mode.
3.
 - CONTRAST Minimum
 - BRIGHTNESS Maximum.
4. V. BLK Adjustment (RV501)
- (1) Adjust RV501(V. BLK) so that the upper side white frame of monoscope signal is not blanked.

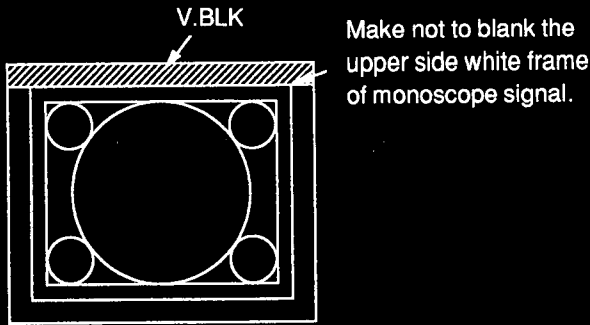

5. H. BLK Adjustment (RV516)
- (1) Adjust with RV516 (H. BLK) so that the left end white vertical line of the white frame of monoscope signal is not blanked as following figure.

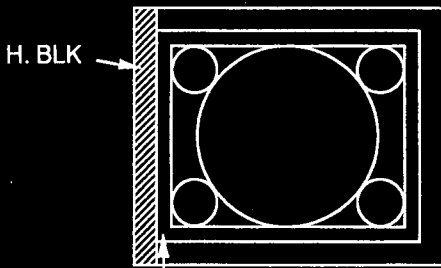

Make not to blank the left end white vertical line of the white frame of monoscope signal.

VERTICAL DEFLECTION PART ADJUSTMENTS (RV504, RV505, RV506, RV507)

1. Receive a monoscope signal.
2.
 - CONTRAST 70%
 - BRIGHTNESS 50%
3. Adjust RV505 (V. SIZE) so that the vertical size of monoscope signal becomes 12 frames.

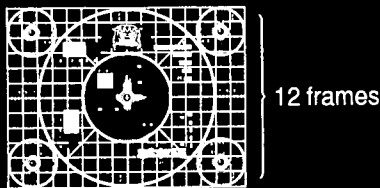

4. Adjust RV507 (V. LIN) the vertical linearity.

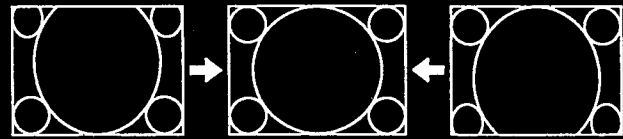

5. Adjust RV504 (V. CENT) the vertical position.

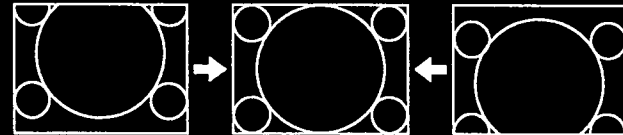

6. V. SIZE ADJUSTMENT (RV505)

- (1) Adjust RV505 (V. SIZE) so that the vertical size of monoscope signal becomes 11.75 +0.2 frames.

7. V. SIZE IN UNDERSCAN MODE ADJUSTMENT (RV506)

- (1) Set U/S (Under Scan) switch to Under mode.
- (2) Adjust the Under V. SIZE with RV506 (U/V. SIZE) as follows.

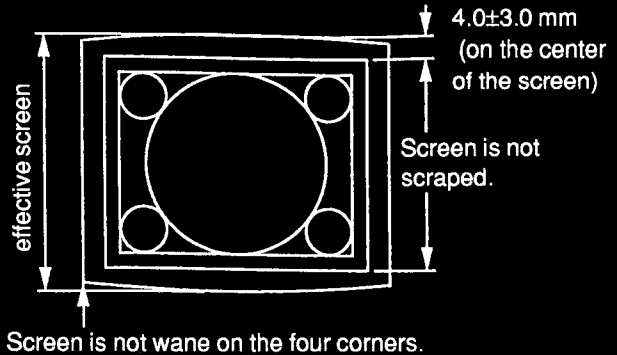

HORIZONTAL DEFLECTION PART ADJUSTMENTS (RV508, RV509, RV511, RV514, RV515, RV801/P board)

1. Receive a monoscope signal.
2.
 - CONTRAST 70%
 - BRIGHTNESS 50%
3. H. CENT Adjustment (RV801 on P board)
- (1) Adjust RV801 on P board (H. CENT) the horizontal position.

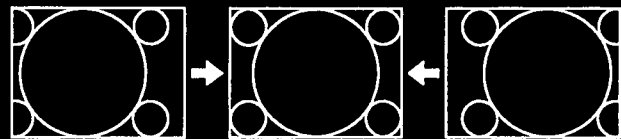

4. H. SIZE Adjustment (RV511)

- (1) Adjust RV511 (H. SIZE) the horizontal size of 16 frames of monoscope signal.

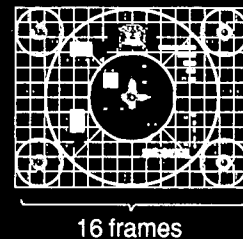

5. PIN AMP. PIN PHASE, V. ANG, BOW ADJUSTMENTS (RV508 RV509, RV514, RV515)

Adjust RV514 (V. ANG) and RV515 (BOW) to correct vertical angular distortion and bow distortion. Adjust RV509 (PIN AMP) and RV508 (PIN PHASE) so that vertical lines become straight.

• V. ANG (RV514)



• BOW (RV515)



• PIN AMP (RV509)



• PIN PHASE (RV508)



6. H. SIZE ADJUSTMENT (RV511)

- (1) Adjust RV511 (H. SIZE) so that the horizontal size becomes 16 ± 0.2 frames.

7. UNDERSCAN MODE H.SIZE ADJUSTMENT (RV512)

- (1) Set U/S (Under Scan) switch to Under mode.
- (2) Adjust RV512 (U/H. SIZE) the Under H. SIZE as shown in the figure.

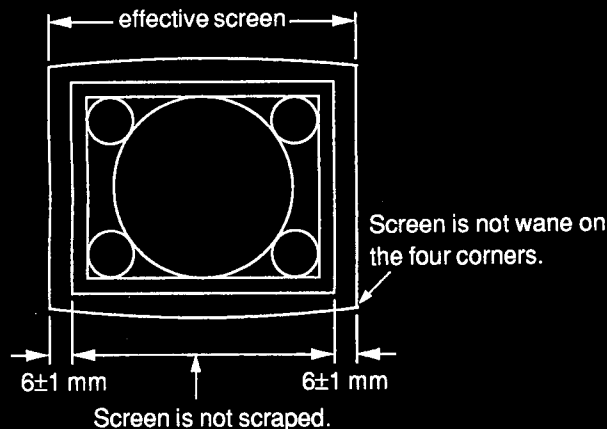

H V DELAY ADJUSTMENT (RV831, RV832)

1. Receive a monoscope signal.
2. • CONTRAST 70%
• BRIGHTNESS 50%
3. Set H V DELAY switch to DELAY mode.
4. H. DELAY Adjustment (RV832)
 - (1) Connect an oscilloscope to pin-④ of IC831.
 - (2) Adjust RV832 (H. DELAY) to become $41 \pm 1 \mu\text{sec}$.

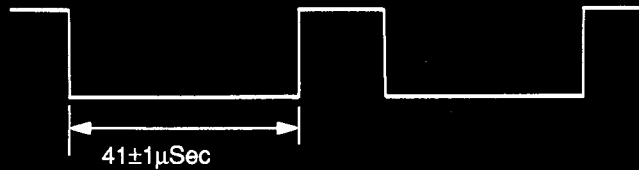

5. V. DELAY Adjustment (RV831)

- (1) Connect an oscilloscope to pin-⑨ of IC833.
- (2) Adjust RV831 to become $8.0 \pm 0.4\text{msec}$ as follows.

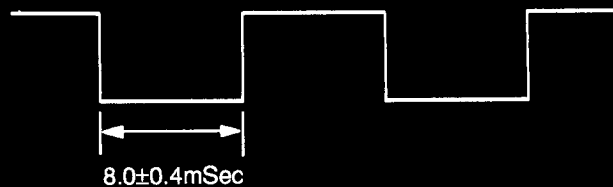

SHUT-DOWN VOLTAGE ADJUSTMENT (RV1602)

1. Fully rotate RV1602 in the direction that does not shut-down.
2. Supply a $9.4\text{V } ^{+0.1}_0$ V voltage to the C1602 side of L1602 on the D board.
3. Turn AC power switch ON.
4. Rotate D board RV1602 (SHT DOWN) slowly to the point that shuts-down the unit.

B+ VOLTAGE DURING DC OPERATE MODE, ADJUSTMENT (RV1601)

1. Supply $DC12\text{V} \pm 0.2\text{V}$ to DC 12V IN connector.
2. Receive a monoscope signal.
3. • CONTRAST 80%
• BRIGHTNESS 50%
4. Connect a digital voltmeter to C1605 + positive side on D board.
5. Adjust RV1601 on the D board for $40.0 \pm 0.1\text{V DC}$.

B BOARD ADJUSTMENT

-B BOARD (COMPONENT SIDE)-

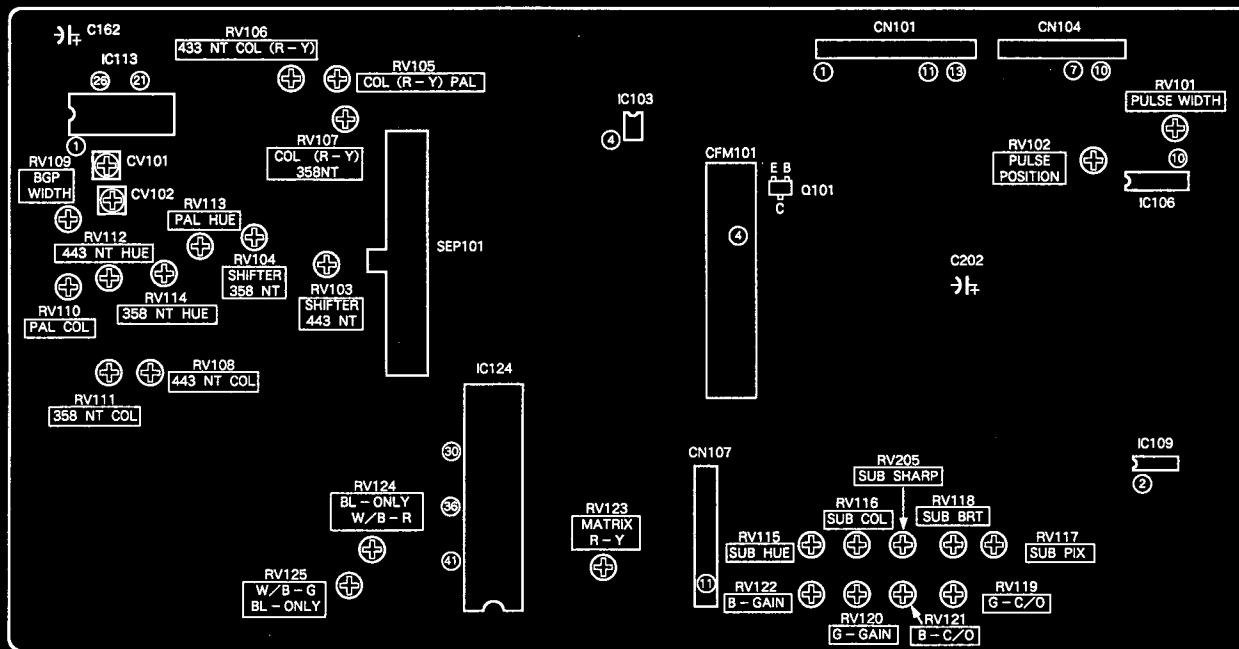

-B BOARD (CONDUCTOR SIDE)-



PRIMARY COLOR MATRIX ADJUSTMENT (RV115, RV116, RV123)

1. Supply component color bar signal (75% chroma color bar) to the equipment so that Y signal is supplied to EXT SYNC and R-Y signal to R-Y connectors. Operate the equipment in external sync mode.
2. Connect oscilloscope to IC124 pin-30 (B-OUT).
3. Adjust RV115 (SUB HUE) to obtain the Blue output as shown in figure.

(B-OUT)

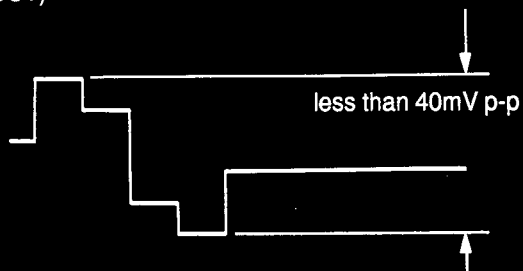

Adjust so that this portion should have minimum amplitude.

4. Supply component color bar signal (75% color bar) to the component input connector to feed R-Y and B-Y signals. Operate the equipment in internal SYNC mode.
5. Connect oscilloscope to IC124 pin-30 (SUB-COL). Adjust RV116 (SUB-COL) so that waveform peaks should have the same level.

(B-OUT)

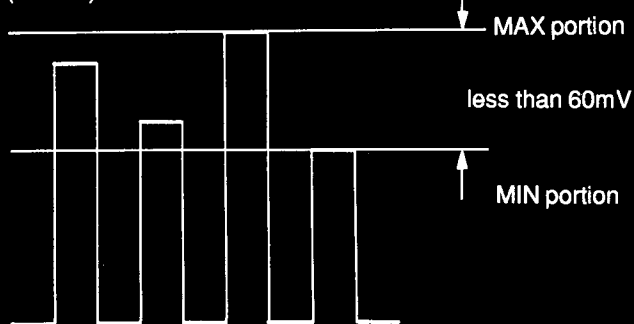

(Adjust so that the first and the 4th peaks should have the same level.)

6. Connect oscilloscope to IC124 pin-41 (R-OUT).
7. Adjust RV123 ((R-Y)-IN) so that waveform peaks should have the same level.

(R-OUT)

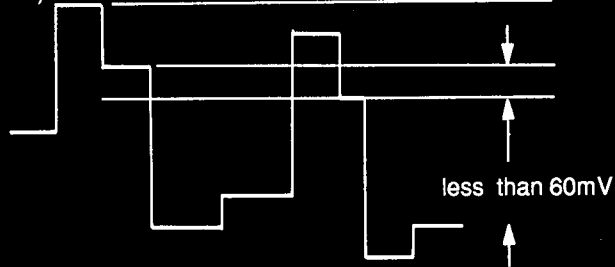

Adjust so that this portion should have minimum amplitude.

BURST GATE PULSE WIDTH ADJUSTMENT (RV109)

1. Receive color bar signal.
2. Connect dual trace oscilloscope to CN104 connector pin-10 (COMP-SYNC) and IC113 (M51279) pin-1 (BGP-WIDTH). Adjust RV109 (BGP-WIDTH) to obtain the relationship as shown in the figure.

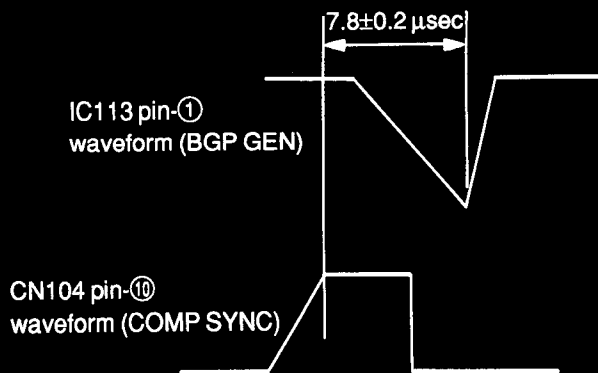

VXO ADJUSTMENT (CV101, CV102)

1. 3.58MHz VXO adjustment (CV101)
 - (1) Receive NTSC color bar signal.
 - (2) Connect +5V power line to IC113 pin-26 (ID-FILT-REF) via a 4700Ω resistor.
 - (3) Ground IC109 pin-2 by connecting it to ground.
 - (4) Ground C162 - negative side by connecting it to ground.
 - (5) Connect frequency counter to IC113 pin-21. Adjust CV101 (358FO) for 3579545±20Hz. (This adjustment can be alternatively done by observing screen as below.)

Adjust color synchronization by CV101 (358FO).

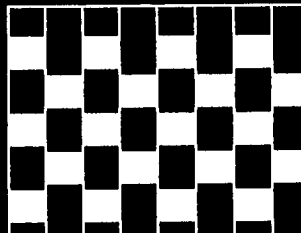

Adjust so that color stripes disappear and the hue change is stabilized extremely.

2. 4.43MHz VXO adjustment (CV102)
 - (1) Receive PAL colour bar signal.
 - (2) Connect +12V power line to IC109 pin-②.
 - (3) Connect frequency counter to IC113 pin-②. Adjust CV102 (443FO) for $4433619 \pm 20\text{Hz}$.
(This adjustment can be alternatively done by observing screen as below.)

Adjust colour synchronization by CV102(443FO).

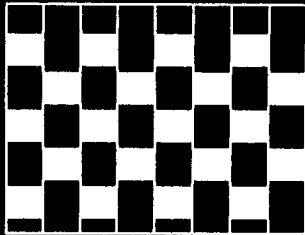

Adjust so that colour stripes disappear and the hue change is stabilized extremely.

**NTSC COMB FILTER ADJUSTMENT
(RV1,T1/CFM101 BOARD)**

1. Receive NTSC 3.58 color bar signal.
2. Connect an oscilloscope to C202 – negative side.
3. Confirm the Y OUT is $0.78 \pm 0.5 \text{ Vp-p}$.
4. Confirm the residual chroma is 32 mVp-p below. If it is above 35 mVp-p, adjust with RV1 and T1 on CFM201 board while tracking.

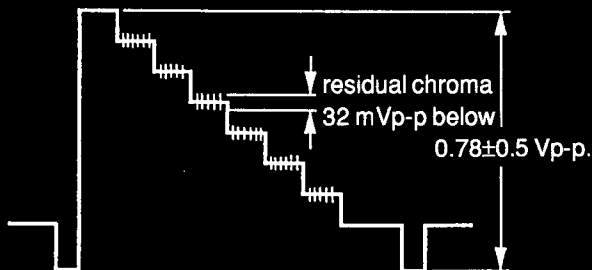

**NTSC COLOR DEMODULATION ADJUSTMENT
(RV114,RV111,RV104,RV107)**

1. NTSC 3.58MHz - HUE adjustment (RV114)
 - (1) Supply NTSC color bar signal including burst and R-Y component.
(For example, Tektronix 1410SG output color bar signal with B-Y component removed.)
 - (2) Connect an oscilloscope to Q128 emitter (B-Y OUT).
 - (3) Adjust RV114 (358NT - HUE) so that all the waveform peaks should have equal amplitude (look flat) except burst. (Level difference should be less than 10mV p-p.)

2. NTSC 3.58MHz - COLOR adjustment (RV111)
 - (1) Receive NTSC 3.58 color bar signal.
 - (2) Connect an oscilloscope to IC124 pin-③ (B-OUT).
 - (3) Adjust RV111(358NT-COL) so that waveform peaks should have the same level (most flat).

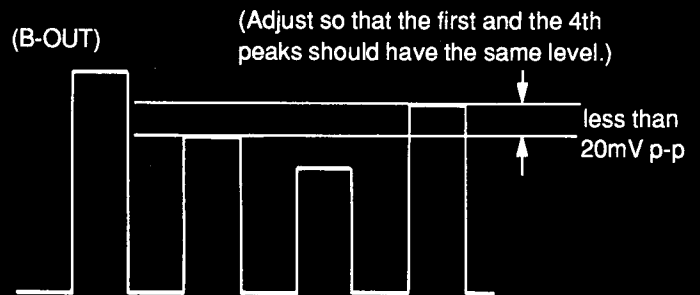

3. NTSC 3.58MHz - COLOR (R-Y) adjustment (RV104, RV107)
 - (1) Receive the color bar signal.
 - (2) Connect an oscilloscope to the Q127 emitter (R-Y OUT), and adjust RV104 (358NT-SHIFT) so that the output of the burst section (B-Y axis signal output) becomes 0.
 - (3) Connect an oscilloscope to IC124 pin-④ (R-OUT). Adjust RV107 (358NT-COL (R-Y)) so that the level difference should be minimum.

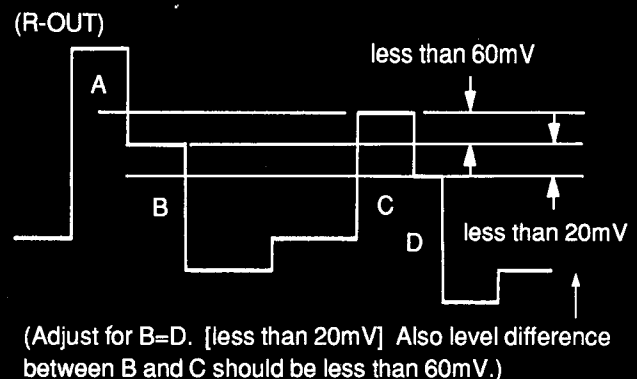

NTSC 4.43MHz COLOR DEMODULATION ADJUSTMENT (RV108,RV112,RV103,RV106)

1. NTSC 4.43MHz - COLOR adjustment (RV108,RV112)
 - (1) Receive NTSC 4.43 color bar signal (75% color bar).
 - (2) Connect an oscilloscope to IC124 pin-⑩ (B-OUT).
 - (3) Adjust RV108 (443NT-COL) so that waveform peaks should have the same level (most flat).

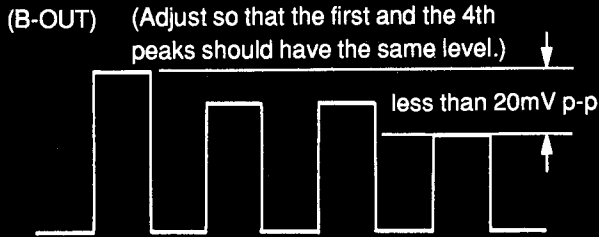

- (4) When cyan and magenta have level difference, adjust RV112 (443NT-HUE) and RV108 (443NT-COL) alternatively to remove, by tracking.

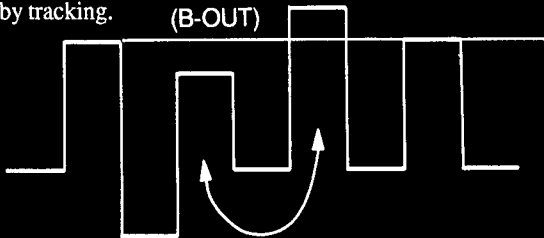

When cyan and magenta have level difference, adjust RV112 and RV108 alternatively to remove.

2. NTSC 4.43MHz - COLOR (R-Y) adjustment (RV103, RV106)
 - (1) Receive the NTSC 4.43 color bar signal (75%, chroma color bar).
 - (2) Connect an oscilloscope to the Q127 emitter (R-Y OUT), and adjust RV103(443NT-SHIFT) so that the output of the burst section (B-Y axis signal output) becomes 0.
 - (3) Connect an oscilloscope to IC124 pin-④ (R-OUT). Adjust RV106 (443NT-COL (R-Y)) so that the level difference should be minimum.

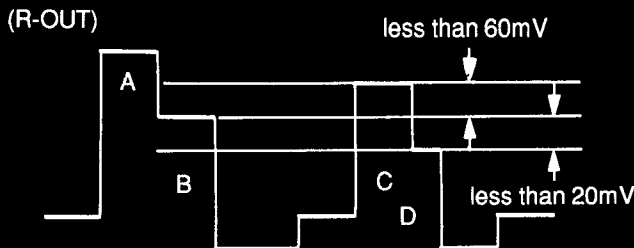

(Adjust for B=D. [less than 20mV] Also level difference between B and C should be less than 60mV.)

PAL COLOR DEMODULATION ADJUSTMENT (RV113,RV2/SEP101, RV110,RV105,RV205)

1. PAL PHASE Adjustment (RV113,RV2/SEP101)
 - (1) Receive the special PAL color-bar.
 - (2) Connect an oscilloscope to emitter of Q127 (R-Y OUT).
 - (3) Adjust RV113 (PAL-PHASE) so that B-Y (0/180°) anti-PAL portion (in the R-Y demodulated output) becomes "0" (flat) as following figure.

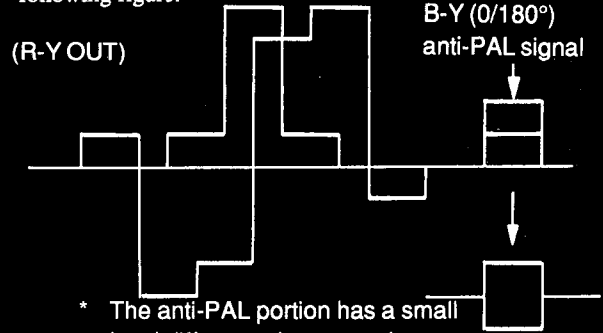

* The anti-PAL portion has a small level difference in every other horizontal period. So, adjust so that average becomes "0".

- (4) Connect an oscilloscope to emitter of Q128 (B-Y OUT).
- (5) Adjust RV2 inside SEP101 so that R-Y (90°/90°) anti-PAL portion (in B-Y demodulated output) becomes "0" (flat) as following figure.

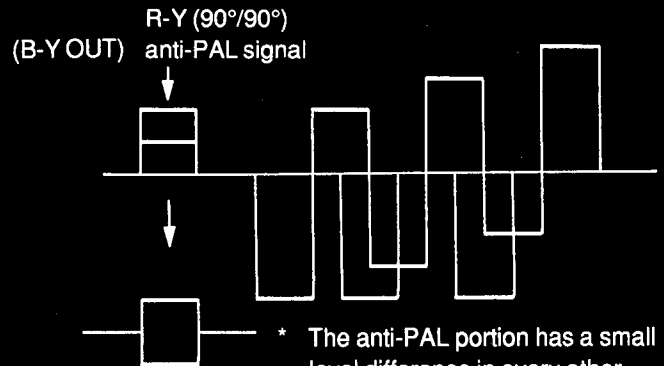

* The anti-PAL portion has a small level difference in every other horizontal period. So, adjust so that average becomes "0".

(For the adjustments of (3) and (5), it is also possible to set the color level to MAX with the chroma adjusting knob of the unit and erase the color of the anti-pal signal section.)

2. PAL COLOR ADJUSTMENT (RV110)

- (1) Receive PAL color bar signal (75% color bar).
- (2) Connect an oscilloscope to IC124 pin-⑩ (B-OUT).
- (3) Adjust RV110 (PAL-COL) so that waveform peaks should have the same level (most flat).

(B-OUT) (Adjust so that the first and the 4th peaks should have the same level.)

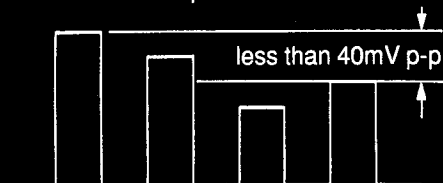

3. PAL-COLOR-(R-Y) ADJUSTMENT (RV105)

- (1) Connect an oscilloscope to IC124 pin-④ (R-OUT).
- (2) Adjust RV105 (PAL-COL-(R-Y)) so that waveform peaks should have the same level (most flat).

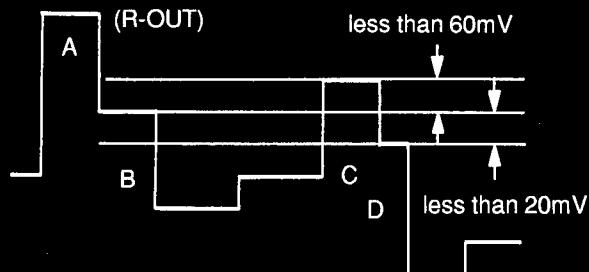

(Adjust for B=D. [less than 20mV] Also level difference between B and C should be less than 60mV.)

SUB-SHARP ADJUSTMENT (RV205)

- (1) Receive a sweep signal (or multi-burst).
 - * Bandwidth should be more than 10MHz (flat).
 - * Composite sync should be included.
 - * Turn burst off.
- (2) Connect an oscilloscope to IC124 pin-③ (G-OUT).
- (3) Adjust RV205 (SUB-SHARP) as shown.

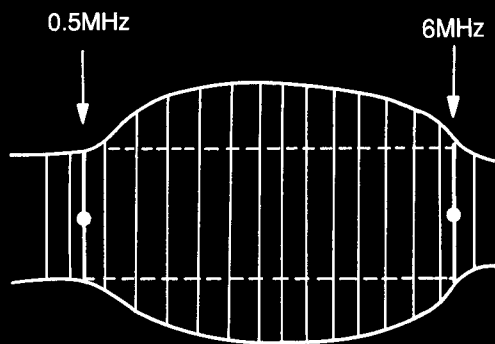

Example of sweep signal output waveform

[specification]

$$6\text{MHz}/0.5\text{MHz}=0\pm 0.5\text{dB}$$

CHROMA H PULSE POSITION ADJUSTMENT (RV101,RV102)

- (1) Receive the SECAM color bar signal.
(The left edge of the screen should not be colored.)
- (2) Set to the under-scan mode.
- (3) Adjust RV101 (PLUSE-WIDTH) until the point immediately before the color on the left edge of the screen disappears.
- (4) Release the under-scan mode.
- (5) Set the HV DELAY mode.
- (6) Adjust RV102 (PULSE-POST) until the point immediately before the rising color of the image after back porch disappears.

Note : If image phase adjustment or HV DELAY amount adjustment during HV DELAY is performed after completing the adjustment in this section, re-adjustments will be required. Therefore, performed this adjustment after the two mentioned have been performed.

S BOARD ADJUSTMENTS

—S BOARD (COMPONENT SIDE)—

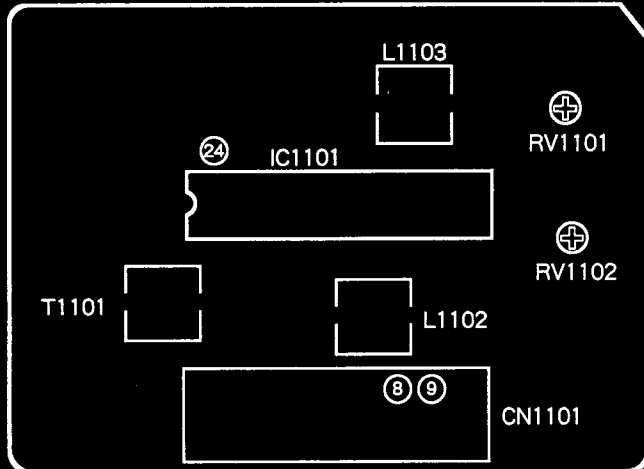

SECAM (T1101, L1102, L1103)

1. Receive SECAM color-bar.
2. Bell Filter Adjustment (T1101)
 - (1) Connect an oscilloscope to IC1101 pin-24.
 - (2) Adjust T1101 (Bell Filter) so that the chroma waveform becomes smooth. (Uneven level should be minimum.)

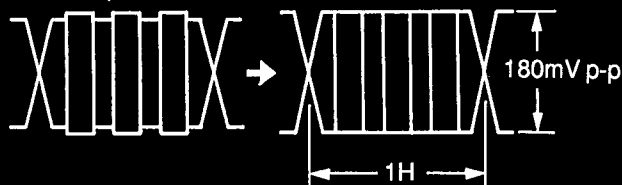

3. Color Balance Adjustment (L1102, L1103)
 - (1) Connect an oscilloscope to pin-9 (R-Y) of CN1101 connector.
 - (2) Adjust L1102 (R-Y) so that the non-colored portion level becomes flat.

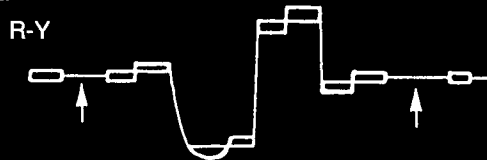

- (3) Connect an oscilloscope to pin-8 (B-Y) of CN1101 connector.
 - (4) Adjust L1103 (B-Y) so that the non-colored portion level becomes flat.



- (5) When adjusting the color level of the unit to MAX or MIN using the chroma adjusting knob, check that the white balance of the colorless section does not change.

DEMODULATION LEVEL ADJUSTMENT (RV1101, RV1102)

1. Receive SECAM color-bar.
2. Connect an oscilloscope to IC124 pin-30 (B-OUT).
3. Adjust S board RV1101 (SEC-COL) so that waveform peaks should have the same level (most flat).

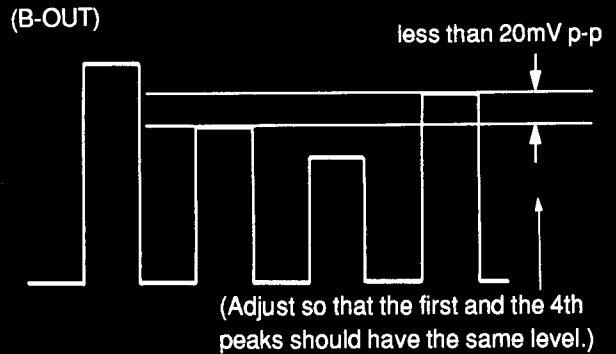

4. Connect an oscilloscope to IC124 pin-41 (R-OUT).
5. Adjust S board RV1102 (SEC-COL (R-Y)) so that the level difference should be minimum.

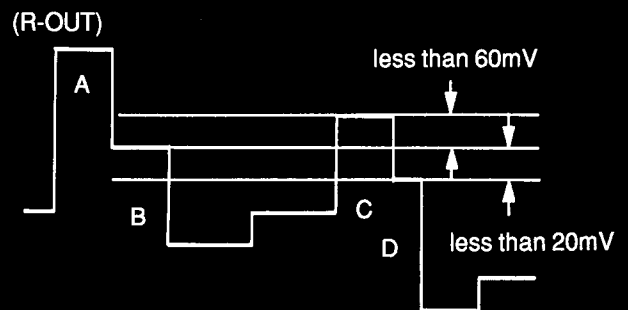

(Adjust for B=D. [less than 20mV] Also level difference between B and C should be less than 60mV.)

7-2. PICTURE TUBE

▲ : BVTP3x12 7-685-648-79

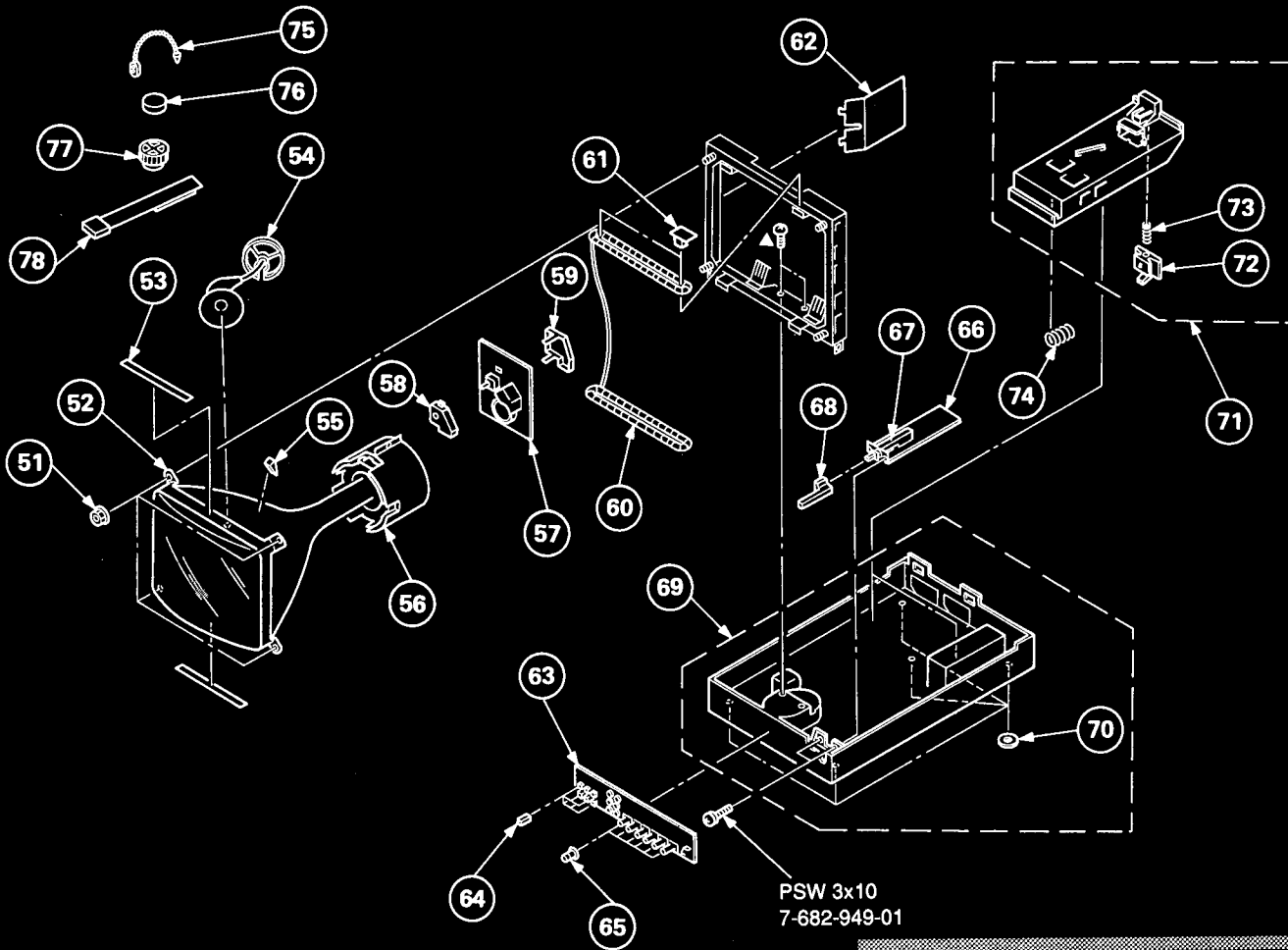

The components identified by shading and mark ▲ are critical for safety. Replace only with part number specified.

Les composants identifiés par une trame et une marque ▲ sont critiques pour la sécurité. Ne les remplacer que par une pièce portant le numéro spécifié.

REF. NO.	PART NO.	DESCRIPTION	REMARK	REF. NO.	PART NO.	DESCRIPTION	REMARK
51	4-304-511-01	FLANGE NUT, 5MM		66	*1-641-723-11	FA BOARD	
52	▲ 8-737-151-05	CRT (A20JKU10X) (PVM-8041Q ONLY)		67	1-692-049-11	SWITCH, PUSH (AC POWER) (1KEY)	
	▲ 8-737-651-05	CRT (M20JMP10X) (PVM-8044Q ONLY)		68	4-034-841-01	SWITCH, POWER	
53	4-035-332-01	CLOTH, PROTECTION		69	*X-4030-166-1	CHASSIS ASSY, BOTTOM	70
54	*4-034-856-01	HOLDER, HV CABLE		70	4-034-840-01	RUBBER, FOOT	
55	4-309-369-03	SPACER, DEFLECTION YOKE		71	*X-4030-163-1	GUIDE ASSY, BATTERY	72,73
56	▲ 1-451-319-22	DEFLECTION YOKE (Y9FXC)		72	4-034-861-01	KNOB, BATTERY	
57	*1-641-720-11	CA BOARD		73	4-876-347-01	SPRING, COMPRESSION	
58	*4-376-133-11	COVER (MAIN), CV VOL		74	3-669-594-00	SPRING, COMPRESSION	
59	*4-376-132-11	COVER (REAR LID), CV VOL		75	4-308-870-00	CLIP, LEAD WIRE	
60	1-426-043-00	COIL, DEGAUSSING		76	1-452-126-11	MAGNET	
61	4-380-534-01	CAP, DGC		77	1-452-094-00	MAGNET, ROTATABLE DISK; 15MM φ	
62	*4-034-850-02	INSULATOR		78	X-4308-815-8	PERMALLOY ASSY, CONVERGENCE	
63	*A-1371-782-A	HA BOARD, COMPLETE					
64	4-034-849-01	SWITCH (SMALL), PUSH					
65	X-4030-162-1	KNOB ASSY, CONTROL					

B

**SECTION 8
ELECTRICAL PARTS LIST**

NOTE:

The components identified by shading and mark **Δ** are critical for safety. Replace only with part number specified.

Les composants identifiés par une trame et une marque **Δ** sont critiques pour la sécurité. Ne les remplacer que par une pièce portant le numéro spécifié.

• Items marked "*" are not stocked since they are seldom required for routine service. Some delay should be anticipated when ordering these items.

• All variable and adjustable resistors have characteristic curve B, unless otherwise noted.

RESISTORS

• All resistors are in ohms
• F: nonflammable

When indicating parts by reference number, please include the board name.

CAPACITORS

• MF: μ F, PF: μ μ F

COILS

• MMH: mH, UH: μ H

• The components identified by **Δ** in this manual have been carefully factory-selected for each set in order to satisfy regulations regarding X-ray radiation.

Should replacement be required, replace only with the value originally used.

REF. NO.	PART NO.	DESCRIPTION	REMARK	REF. NO.	PART NO.	DESCRIPTION	REMARK
A-1135-700-A	B BOARD, COMPLETE	*****		C142	1-163-031-11	CERAMIC CHIP 0.01MF	50V
3-710-578-01	COVER, VOLUME, 6 MOLD			C143	1-163-121-00	CERAMIC CHIP 150PF	5% 50V
	<BAND PASS FILTER>			C144	1-163-101-00	CERAMIC CHIP 22PF	5% 50V
BPF101	1-236-363-11	FILTER, BAND PASS		C145	1-163-131-00	CERAMIC CHIP 390PF	5% 50V
BPF102	1-236-364-11	FILTER, BAND PASS		C146	1-126-157-11	ELECT 10MF	20% 16V
	<CAPACITOR>			C147	1-164-232-11	CERAMIC CHIP 0.01MF	10% 50V
C101	1-124-589-11	ELECT 47MF	20% 16V	C148	1-126-160-11	ELECT 1MF	20% 50V
C102	1-163-031-11	CERAMIC CHIP 0.01MF	50V	C149	1-163-022-00	CERAMIC CHIP 0.012MF	10% 50V
C103	1-126-320-11	ELECT 10MF	20% 16V	C150	1-124-589-11	ELECT 47MF	20% 16V
C104	1-163-031-11	CERAMIC CHIP 0.01MF	50V	C151	1-163-131-00	CERAMIC CHIP 390PF	5% 50V
C105	1-163-031-11	CERAMIC CHIP 0.01MF	50V	C152	1-163-101-00	CERAMIC CHIP 22PF	5% 50V
C106	1-124-477-11	ELECT 47MF	20% 16V	C153	1-163-125-00	CERAMIC CHIP 220PF	5% 50V
C107	1-163-031-11	CERAMIC CHIP 0.01MF	50V	C154	1-163-031-11	CERAMIC CHIP 0.01MF	50V
C108	1-124-477-11	ELECT 47MF	20% 16V	C155	1-163-133-00	CERAMIC CHIP 470PF	5% 50V
C109	1-124-477-11	ELECT 47MF	20% 16V	C156	1-164-299-11	CERAMIC CHIP 0.22MF	10% 25V
C110	1-124-120-11	ELECT 220MF	20% 16V	C157	1-163-229-11	CERAMIC CHIP 12PF	5% 50V
C111	1-163-031-11	CERAMIC CHIP 0.01MF	50V	C158	1-124-477-11	ELECT 47MF	20% 16V
C112	1-163-031-11	CERAMIC CHIP 0.01MF	50V	C159	1-163-229-11	CERAMIC CHIP 12PF	5% 50V
C113	1-163-031-11	CERAMIC CHIP 0.01MF	50V	C160	1-163-229-11	CERAMIC CHIP 12PF	5% 50V
C114	1-124-477-11	ELECT 47MF	20% 16V	C161	1-124-902-00	ELECT 0.47MF	20% 50V
C115	1-163-031-11	CERAMIC CHIP 0.01MF	50V	C162	1-124-903-11	ELECT 1MF	20% 50V
C116	1-124-477-11	ELECT 47MF	20% 16V	C163	1-163-809-11	CERAMIC CHIP 0.047MF	10% 25V
C117	1-124-477-11	ELECT 47MF	20% 16V	C164	1-163-809-11	CERAMIC CHIP 0.047MF	10% 25V
C118	1-124-477-11	ELECT 47MF	20% 16V	C165	1-163-009-11	CERAMIC CHIP 0.001MF	10% 50V
C119	1-163-031-11	CERAMIC CHIP 0.01MF	50V	C166	1-163-031-11	CERAMIC CHIP 0.01MF	50V
C120	1-124-477-11	ELECT 47MF	20% 16V	C167	1-124-477-11	ELECT 47MF	20% 16V
C121	1-124-477-11	ELECT 47MF	20% 16V	C168	1-163-031-11	CERAMIC CHIP 0.01MF	50V
C122	1-124-477-11	ELECT 47MF	20% 16V	C169	1-163-243-11	CERAMIC CHIP 47PF	5% 50V
C123	1-163-031-11	CERAMIC CHIP 0.01MF	50V	C170	1-163-129-00	CERAMIC CHIP 330PF	5% 50V
C124	1-163-031-11	CERAMIC CHIP 0.01MF	50V	C171	1-163-243-11	CERAMIC CHIP 47PF	5% 50V
C125	1-124-477-11	ELECT 47MF	20% 16V	C172	1-163-129-00	CERAMIC CHIP 330PF	5% 50V
C126	1-163-031-11	CERAMIC CHIP 0.01MF	50V	C173	1-124-589-11	ELECT 47MF	20% 16V
C127	1-124-477-11	ELECT 47MF	20% 16V	C174	1-124-477-11	ELECT 47MF	20% 16V
C128	1-124-477-11	ELECT 47MF	20% 16V	C175	1-108-792-11	MYLAR 0.001MF	5% 50V
C129	1-163-031-11	CERAMIC CHIP 0.01MF	50V	C176	1-163-031-11	CERAMIC CHIP 0.01MF	50V
C130	1-163-031-11	CERAMIC CHIP 0.01MF	50V	C177	1-163-031-11	CERAMIC CHIP 0.01MF	50V
C131	1-163-031-11	CERAMIC CHIP 0.01MF	50V	C178	1-163-031-11	CERAMIC CHIP 0.01MF	50V
C132	1-124-589-11	ELECT 47MF	20% 16V	C179	1-126-160-11	ELECT 1MF	20% 50V
C133	1-124-589-11	ELECT 47MF	20% 16V	C180	1-163-031-11	CERAMIC CHIP 0.01MF	50V
C134	1-163-275-11	CERAMIC CHIP 0.001MF	5% 50V	C181	1-126-154-11	ELECT 47MF	20% 6.3V
C135	1-163-113-00	CERAMIC CHIP 68PF	5% 50V	C182	1-126-163-11	ELECT 4.7MF	20% 16V
C137	1-163-115-00	CERAMIC CHIP 82PF	5% 50V	C183	1-164-232-11	CERAMIC CHIP 0.01MF	10% 50V
C138	1-124-589-11	ELECT 47MF	20% 16V	C184	1-163-031-11	CERAMIC CHIP 0.01MF	50V
C139	1-163-031-11	CERAMIC CHIP 0.01MF	50V	C185	1-163-031-11	CERAMIC CHIP 0.01MF	50V
C140	1-163-688-91	CERAMIC CHIP 0.001MF	5% 50V	C186	1-163-099-00	CERAMIC CHIP 18PF	5% 50V
C141	1-163-141-00	CERAMIC CHIP 0.001MF	5% 50V	C187	1-163-031-11	CERAMIC CHIP 0.01MF	50V
				C188	1-163-031-11	CERAMIC CHIP 0.01MF	50V
				C189	1-163-035-00	CERAMIC CHIP 0.047MF	50V
				C190	1-163-121-00	CERAMIC CHIP 150PF	5% 50V
				C191	1-163-031-11	CERAMIC CHIP 0.01MF	50V

REF. NO.	PART NO.	DESCRIPTION	REMARK	REF. NO.	PART NO.	DESCRIPTION	REMARK
C192	1-163-031-11	CERAMIC CHIP 0.01MF	50V	C258	1-163-129-00	CERAMIC CHIP 330PF	5% 50V
C193	1-124-589-11	ELECT 47MF	20% 16V	C259	1-163-031-11	CERAMIC CHIP 0.01MF	50V
C194	1-124-589-11	ELECT 47MF	20% 16V	C260	1-124-465-00	ELECT 0.47MF	20% 50V
C195	1-124-589-11	ELECT 47MF	20% 16V	C261	1-137-193-11	FILM 0.39MF	5% 50V
C196	1-124-589-11	ELECT 47MF	20% 16V	C262	1-124-465-00	ELECT 0.47MF	20% 50V
C197	1-124-589-11	ELECT 47MF	20% 16V	C264	1-163-123-00	CERAMIC CHIP 180PF	5% 50V
C198	1-124-589-11	ELECT 47MF	20% 16V	C265	1-163-129-00	CERAMIC CHIP 330PF	5% 50V
C199	1-124-589-11	ELECT 47MF	20% 16V	C266	1-126-320-11	ELECT 10MF	20% 16V
C202	1-124-589-11	ELECT 47MF	20% 16V	C267	1-126-320-11	ELECT 10MF	20% 16V
C203	1-124-589-11	ELECT 47MF	20% 16V	C268	1-124-477-11	ELECT 47MF	20% 16V
C204	1-124-589-11	ELECT 47MF	20% 16V	C269	1-164-004-11	CERAMIC CHIP 0.1MF	10% 25V
C205	1-163-101-00	CERAMIC CHIP 22PF	5% 50V	C270	1-164-004-11	CERAMIC CHIP 0.1MF	10% 25V
C206	1-164-298-11	CERAMIC CHIP 0.15MF	10% 25V	C271	1-163-809-11	CERAMIC CHIP 0.047MF	10% 25V
C207	1-164-298-11	CERAMIC CHIP 0.15MF	10% 25V	C272	1-163-129-00	CERAMIC CHIP 330PF	5% 50V
C208	1-163-101-00	CERAMIC CHIP 22PF	5% 50V	C273	1-163-129-00	CERAMIC CHIP 330PF	5% 50V
C209	1-164-004-11	CERAMIC CHIP 0.1MF	10% 25V	C274	1-124-477-11	ELECT 47MF	20% 16V
C210	1-124-589-11	ELECT 47MF	20% 16V	C275	1-163-119-00	CERAMIC CHIP 120PF	5% 50V
C211	1-124-589-11	ELECT 47MF	20% 16V	C277	1-163-097-00	CERAMIC CHIP 15PF	5% 50V
C212	1-124-589-11	ELECT 47MF	20% 16V	C278	1-163-809-11	CERAMIC CHIP 0.047MF	10% 25V
C213	1-124-589-11	ELECT 47MF	20% 16V	C279	1-126-157-11	ELECT 10MF	20% 16V
C214	1-126-157-11	ELECT 10MF	20% 16V	C280	1-163-117-00	CERAMIC CHIP 100PF	5% 50V
C215	1-126-157-11	ELECT 10MF	20% 16V	C281	1-163-031-11	CERAMIC CHIP 0.01MF	50V
C216	1-126-157-11	ELECT 10MF	20% 16V	C282	1-163-031-11	CERAMIC CHIP 0.01MF	50V
C217	1-163-031-11	CERAMIC CHIP 0.01MF	50V	C283	1-163-031-11	CERAMIC CHIP 0.01MF	50V
C218	1-164-298-11	CERAMIC CHIP 0.15MF	10% 25V	C299	1-163-031-11	CERAMIC CHIP 0.01MF	50V
C219	1-163-009-11	CERAMIC CHIP 0.001MF	10% 50V	C300	1-126-157-11	ELECT 10MF	20% 16V
C220	1-163-031-11	CERAMIC CHIP 0.01MF	50V	C301	1-163-809-11	CERAMIC CHIP 0.047MF	10% 25V
C221	1-124-903-11	ELECT 1MF	20% 50V	C302	1-124-589-11	ELECT 47MF	20% 16V
C222	1-163-093-00	CERAMIC CHIP 10PF	5% 50V	C303	1-126-157-11	ELECT 10MF	20% 16V
C223	1-163-031-11	CERAMIC CHIP 0.01MF	50V	C304	1-163-125-00	CERAMIC CHIP 220PF	5% 50V
C225	1-124-477-11	ELECT 47MF	20% 16V	C305	1-124-257-00	ELECT 2.2MF	20% 50V
C226	1-163-031-11	CERAMIC CHIP 0.01MF	50V	C306	1-163-115-00	CERAMIC CHIP 82PF	5% 50V
C227	1-163-038-00	CERAMIC CHIP 0.1MF	25V	C307	1-163-145-00	CERAMIC CHIP 0.0015MF	5% 50V
C228	1-163-986-00	CERAMIC CHIP 0.027MF	10% 25V	C308	1-164-004-11	CERAMIC CHIP 0.1MF	10% 25V
C229	1-163-031-11	CERAMIC CHIP 0.01MF	50V	C309	1-164-004-11	CERAMIC CHIP 0.1MF	10% 25V
C230	1-163-038-00	CERAMIC CHIP 0.1MF	25V	C310	1-164-004-11	CERAMIC CHIP 0.1MF	10% 25V
C231	1-163-986-00	CERAMIC CHIP 0.027MF	10% 25V	C312	1-163-031-11	CERAMIC CHIP 0.01MF	50V
C232	1-163-031-11	CERAMIC CHIP 0.01MF	50V	C313	1-163-115-00	CERAMIC CHIP 82PF	5% 50V
C233	1-163-031-11	CERAMIC CHIP 0.01MF	50V	C314	1-126-157-11	ELECT 10MF	20% 16V
C234	1-163-038-00	CERAMIC CHIP 0.1MF	25V	C315	1-164-299-11	CERAMIC CHIP 0.22MF	10% 25V
C235	1-163-986-00	CERAMIC CHIP 0.027MF	10% 25V	C316	1-126-157-11	ELECT 10MF	20% 16V
C236	1-163-031-11	CERAMIC CHIP 0.01MF	50V	C317	1-163-031-11	CERAMIC CHIP 0.01MF	50V
C237	1-163-031-11	CERAMIC CHIP 0.01MF	50V	C318	1-163-095-00	CERAMIC CHIP 12PF	5% 50V
C238	1-164-299-11	CERAMIC CHIP 0.22MF	10% 25V	C319	1-163-095-00	CERAMIC CHIP 12PF	5% 50V
C239	1-163-809-11	CERAMIC CHIP 0.047MF	10% 25V	C320	1-163-095-00	CERAMIC CHIP 12PF	5% 50V
C240	1-163-809-11	CERAMIC CHIP 0.047MF	10% 25V	C321	1-163-121-00	CERAMIC CHIP 150PF	5% 50V
C241	1-163-809-11	CERAMIC CHIP 0.047MF	10% 25V	C322	1-163-121-00	CERAMIC CHIP 150PF	5% 50V
C242	1-163-113-00	CERAMIC CHIP 68PF	5% 50V	C324	1-163-121-00	CERAMIC CHIP 150PF	5% 50V
C243	1-163-031-11	CERAMIC CHIP 0.01MF	50V	C340	1-163-688-91	CERAMIC CHIP 0.001MF	5% 50V
C244	1-163-103-00	CERAMIC CHIP 27PF	5% 50V	C344	1-163-092-00	CERAMIC CHIP 9PF	0.25PF 50V
C245	1-163-105-00	CERAMIC CHIP 33PF	5% 50V	C345	1-163-109-00	CERAMIC CHIP 47PF	5% 50V
C246	1-163-809-11	CERAMIC CHIP 0.047MF	10% 25V	C346	1-163-109-00	CERAMIC CHIP 47PF	5% 50V
C247	1-163-809-11	CERAMIC CHIP 0.047MF	10% 25V	C347	1-163-109-00	CERAMIC CHIP 47PF	5% 50V
C248	1-163-809-11	CERAMIC CHIP 0.047MF	10% 25V	C1293	1-163-119-00	CERAMIC CHIP 120PF	5% 50V
C249	1-126-101-11	ELECT 100MF	20% 16V	C1294	1-163-119-00	CERAMIC CHIP 120PF	5% 50V
C250	1-163-017-00	CERAMIC CHIP 0.0047MF	10% 50V	C1295	1-163-119-00	CERAMIC CHIP 120PF	5% 50V
C251	1-110-364-11	MYLAR 0.1MF	10% 200V	C1296	1-163-115-00	CERAMIC CHIP 82PF	5% 50V
C252	1-123-935-00	ELECT 33MF	20% 160V	C1297	1-163-103-00	CERAMIC CHIP 27PF	5% 50V
C253	1-124-477-11	ELECT 47MF	20% 16V	C1298	1-163-113-00	CERAMIC CHIP 68PF	5% 50V
C254	1-163-031-11	CERAMIC CHIP 0.01MF	50V	C1299	1-163-093-00	CERAMIC CHIP 10PF	5% 50V
C255	1-124-477-11	ELECT 47MF	20% 16V	C1300	1-126-160-11	ELECT 1MF	20% 50V
C256	1-163-129-00	CERAMIC CHIP 330PF	5% 50V	C1301	1-126-160-11	ELECT 1MF	20% 50V
C257	1-163-129-00	CERAMIC CHIP 330PF	5% 50V	C1302	1-126-160-11	ELECT 1MF	20% 50V

B

REF. NO.	PART NO.	DESCRIPTION	REMARK	REF. NO.	PART NO.	DESCRIPTION	REMARK
C1303	1-126-160-11	ELECT 1MF 20%	50V	D135	8-719-404-46	DIODE MA110	
		<FILTER BLOCK>		D136	8-719-404-46	DIODE MA110	
CFM101	1-464-880-11	FILTER BLOCK, COM (CFB-2)		D137	8-719-404-46	DIODE MA110	
		<CONNECTOR>		D138	8-719-404-46	DIODE MA110	
CN101	1-506-480-11	PIN, CONNECTOR 15P		D139	8-719-404-46	DIODE MA110	
CN102	*1-564-506-11	PLUG, CONNECTOR 3P		D142	8-719-404-46	DIODE MA110	
CN103	*1-565-503-11	CONNECTOR, BOARD TO BOARD 12P		D143	8-719-404-46	DIODE MA110	
CN104	1-506-477-11	PIN, CONNECTOR 12P		D144	8-719-404-46	DIODE MA110	
CN105	*1-564-509-11	PLUG, CONNECTOR 6P		D145	8-719-404-46	DIODE MA110	
CN106	1-506-473-11	PIN, CONNECTOR 8P		D146	8-719-404-46	DIODE MA110	
CN107	1-506-478-11	PIN, CONNECTOR 13P		D147	8-719-404-46	DIODE MA110	
CN108	*1-564-506-11	PLUG, CONNECTOR 3P		D148	8-719-404-46	DIODE MA110	
		<TRAP MODULE>		D149	8-719-404-46	DIODE MA110	
CTR101	1-236-366-11	MODULE, TRAP		D150	8-719-404-46	DIODE MA110	
CTR102	1-236-365-11	MODULE, TRAP		D151	8-719-404-46	DIODE MA110	
		<TRIMMER>		D152	8-719-404-46	DIODE MA110	
CV101	1-141-245-00	CAP, TRIMMER		D153	8-719-977-20	DIODE DTZ8.2B	
CV102	1-141-245-00	CAP, TRIMMER		D154	8-719-404-46	DIODE MA110	
		<DIODE>		D155	8-719-404-46	DIODE MA110	
D101	8-719-404-46	DIODE MA110		D156	8-719-404-46	DIODE MA110	
D102	8-719-404-46	DIODE MA110		D157	8-719-901-83	DIODE 1SS83	
D103	8-719-404-46	DIODE MA110		D158	8-719-901-83	DIODE 1SS83	
D104	8-719-404-46	DIODE MA110		D159	8-719-901-83	DIODE 1SS83	
D105	8-719-404-46	DIODE MA110		D160	8-719-404-46	DIODE MA110	
D106	8-719-404-46	DIODE MA110		D161	8-719-404-46	DIODE MA110	
D107	8-719-404-46	DIODE MA110		D162	8-719-404-46	DIODE MA110	
D108	8-719-404-46	DIODE MA110		D170	8-719-404-46	DIODE MA110	
D109	8-719-404-46	DIODE MA110		D171	8-719-404-46	DIODE MA110	
D110	8-719-404-46	DIODE MA110		D172	8-719-404-46	DIODE MA110	
D111	8-719-404-46	DIODE MA110		D285	8-719-404-46	DIODE MA110	
D112	8-719-404-46	DIODE MA110		D289	8-719-404-46	DIODE MA110	
D113	8-719-404-46	DIODE MA110		D341	8-719-404-46	DIODE MA110	
D114	8-719-404-46	DIODE MA110		D342	8-719-104-34	DIODE 1S2836	
D115	8-719-404-46	DIODE MA110		D343	8-719-800-76	DIODE 1SS226	
D116	8-719-404-46	DIODE MA110		D344	8-719-105-99	DIODE RD6.2M-B1	
D117	8-719-404-46	DIODE MA110		D345	8-719-901-83	DIODE 1SS83	
D118	8-719-404-46	DIODE MA110		D346	8-719-901-83	DIODE 1SS83	
D119	8-719-404-46	DIODE MA110		D347	8-719-901-83	DIODE 1SS83	
D120	8-719-404-46	DIODE MA110		D348	8-719-800-76	DIODE 1SS226	
D121	8-719-404-46	DIODE MA110		D349	8-719-800-76	DIODE 1SS226	
D122	8-719-404-46	DIODE MA110		D350	8-719-800-76	DIODE 1SS226	
D123	8-719-404-46	DIODE MA110		D393	8-719-404-46	DIODE MA110	
D125	8-719-404-46	DIODE MA110				<DELAY LINE>	
D126	8-719-404-46	DIODE MA110		DL101	1-415-632-11	DELAY LINE, Y	
D127	8-719-404-46	DIODE MA110		DL102	1-415-633-11	DELAY LINE, Y	
D128	8-719-400-18	DIODE MA152WK				<IC>	
D129	8-719-404-46	DIODE MA110		IC101	8-759-048-09	IC MM1148XF	
D130	8-719-800-76	DIODE 1SS226		IC102	8-759-501-21	IC MM1149XF	
D131	8-719-800-76	DIODE 1SS226		IC103	8-759-501-21	IC MM1149XF	
D132	8-719-800-76	DIODE 1SS226		IC104	8-759-501-21	IC MM1149XF	
D133	8-719-404-46	DIODE MA110		IC105	8-759-048-09	IC MM1148XF	
D134	8-719-404-46	DIODE MA110		IC106	8-759-009-51	IC MC14538BF	
				IC107	8-759-509-57	IC XRU4584BF	
				IC108	8-759-509-17	IC XRU4053BF	
				IC109	8-759-509-37	IC XRU4070BF	
				IC110	8-759-509-17	IC XRU4053BF	
				IC111	8-759-509-17	IC XRU4053BF	
				IC112	8-759-924-12	IC LM7805CT	

REF. NO.	PART NO.	DESCRIPTION	REMARK	REF. NO.	PART NO.	DESCRIPTION	REMARK
IC113	8-759-631-08	IC M51279FP					
IC114	8-759-509-13	IC XRU4052BF		Q123	8-729-920-74	TRANSISTOR 2SC2412K-QR	
IC115	8-759-509-13	IC XRU4052BF		Q124	8-729-216-22	TRANSISTOR 2SA1162-G	
IC116	8-759-509-05	IC XRU4066BF		Q125	8-729-920-74	TRANSISTOR 2SC2412K-QR	
IC117	8-759-711-32	IC NJM2245M		Q126	8-729-901-01	TRANSISTOR DTC144EK	
				Q127	8-729-216-22	TRANSISTOR 2SA1162-G	
IC118	8-759-711-32	IC NJM2245M					
IC119	8-759-711-32	IC NJM2245M		Q128	8-729-216-22	TRANSISTOR 2SA1162-G	
IC120	8-759-509-05	IC XRU4066BF		Q129	8-729-901-01	TRANSISTOR DTC144EK	
IC121	8-759-509-17	IC XRU4053BF		Q130	8-729-216-22	TRANSISTOR 2SA1162-G	
IC122	8-759-998-98	IC LM358D		Q131	8-729-920-74	TRANSISTOR 2SC2412K-QR	
				Q132	8-729-216-22	TRANSISTOR 2SA1162-G	
IC123	8-759-998-98	IC LM358D					
IC124	8-752-052-62	IC CXA1478S		Q133	8-729-920-74	TRANSISTOR 2SC2412K-QR	
IC125	8-759-509-05	IC XRU4066BF		Q134	8-729-901-01	TRANSISTOR DTC144EK	
IC126	8-759-509-17	IC XRU4053BF		Q135	8-729-920-74	TRANSISTOR 2SC2412K-QR	
IC127	8-759-998-98	IC LM358D		Q136	8-729-907-26	TRANSISTOR 1MX1	
				Q137	8-729-907-26	TRANSISTOR 1MX1	
IC128	8-759-998-98	IC LM358D		Q138	8-729-907-26	TRANSISTOR 1MX1	
IC129	8-759-998-98	IC LM358D		Q139	8-729-216-22	TRANSISTOR 2SA1162-G	
				Q140	8-729-920-74	TRANSISTOR 2SC2412K-QR	
				Q141	8-729-920-74	TRANSISTOR 2SC2412K-QR	
				Q142	8-729-920-74	TRANSISTOR 2SC2412K-QR	
				Q143	8-729-920-74	TRANSISTOR 2SC2412K-QR	
				Q144	8-729-920-74	TRANSISTOR 2SC2412K-QR	
				Q145	8-729-920-74	TRANSISTOR 2SC2412K-QR	
				Q146	8-729-255-12	TRANSISTOR 2SC2551-0	
				Q147	8-729-255-12	TRANSISTOR 2SC2551-0	
				Q148	8-729-216-22	TRANSISTOR 2SA1162-G	
				Q149	8-729-200-17	TRANSISTOR 2SA1091-0	
				Q150	8-729-920-74	TRANSISTOR 2SC2412K-QR	
				Q151	8-729-216-22	TRANSISTOR 2SA1162-G	
				Q152	8-729-200-17	TRANSISTOR 2SA1091-0	
				Q153	8-729-920-74	TRANSISTOR 2SC2412K-QR	
				Q154	8-729-216-22	TRANSISTOR 2SA1162-G	
				Q155	8-729-200-17	TRANSISTOR 2SA1091-0	
				Q157	8-729-326-11	TRANSISTOR 2SC2611	
				Q158	8-729-326-11	TRANSISTOR 2SC2611	
				Q159	8-729-326-11	TRANSISTOR 2SC2611	
				Q160	8-729-920-74	TRANSISTOR 2SC2412K-QR	
				Q161	8-729-216-22	TRANSISTOR 2SA1162-G	
				Q162	8-729-920-74	TRANSISTOR 2SC2412K-QR	
				Q163	8-729-920-74	TRANSISTOR 2SC2412K-QR	
				Q164	8-729-901-01	TRANSISTOR DTC144EK	
				Q165	8-729-216-22	TRANSISTOR 2SA1162-G	
				Q166	8-729-216-22	TRANSISTOR 2SA1162-G	
				Q167	8-729-216-22	TRANSISTOR 2SA1162-G	
				Q168	8-729-216-22	TRANSISTOR 2SA1162-G	
				Q170	8-729-920-74	TRANSISTOR 2SC2412K-QR	
				Q171	8-729-920-74	TRANSISTOR 2SC2412K-QR	
				Q172	8-729-920-74	TRANSISTOR 2SC2412K-QR	
				Q173	8-729-216-22	TRANSISTOR 2SA1162-G	
				Q174	8-729-216-22	TRANSISTOR 2SA1162-G	
				Q175	8-729-216-22	TRANSISTOR 2SA1162-G	
				Q176	8-729-216-22	TRANSISTOR 2SA1162-G	
				Q177	8-729-920-74	TRANSISTOR 2SC2412K-QR	
				Q178	8-729-920-74	TRANSISTOR 2SC2412K-QR	
				Q179	8-729-901-01	TRANSISTOR DTC144EK	
				Q190	8-729-216-22	TRANSISTOR 2SA1162-G	
				Q191	8-729-920-74	TRANSISTOR 2SC2412K-QR	
				Q192	8-729-920-74	TRANSISTOR 2SC2412K-QR	
				Q193	8-729-920-74	TRANSISTOR 2SC2412K-QR	
				Q194	8-729-920-74	TRANSISTOR 2SC2412K-QR	
				Q195	8-729-216-22	TRANSISTOR 2SA1162-G	
				Q196	8-729-920-74	TRANSISTOR 2SC2412K-QR	
				Q197	8-729-216-22	TRANSISTOR 2SA1162-G	

B

REF. NO.	PART NO.	DESCRIPTION	REMARK	REF. NO.	PART NO.	DESCRIPTION	REMARK
Q198	8-729-216-22	TRANSISTOR 2SA1162-G		R141	1-216-063-00	METAL GLAZE 3.9K 5%	1/10W
Q199	8-729-216-22	TRANSISTOR 2SA1162-G		R142	1-216-073-00	METAL GLAZE 10K 5%	1/10W
Q200	8-729-901-06	TRANSISTOR DTA144EK		R143	1-216-085-00	METAL GLAZE 33K 5%	1/10W
Q201	8-729-216-22	TRANSISTOR 2SA1162-G		R145	1-216-065-00	METAL GLAZE 4.7K 5%	1/10W
Q202	8-729-216-22	TRANSISTOR 2SA1162-G		R146	1-216-037-00	METAL GLAZE 330 5%	1/10W
Q203	8-729-216-22	TRANSISTOR 2SA1162-G		R147	1-216-089-00	METAL GLAZE 47K 5%	1/10W
Q204	8-729-216-22	TRANSISTOR 2SA1162-G		R148	1-216-671-11	METAL CHIP 6.8K 0.50%	1/10W
Q205	8-729-216-22	TRANSISTOR 2SA1162-G		R155	1-216-655-11	METAL CHIP 1.5K 0.50%	1/10W
Q206	8-729-216-22	TRANSISTOR 2SA1162-G		R157	1-216-679-11	METAL CHIP 15K 0.50%	1/10W
Q207	8-729-901-01	TRANSISTOR DTC144EK		R158	1-216-677-11	METAL CHIP 12K 0.50%	1/10W
Q208	8-729-216-22	TRANSISTOR 2SA1162-G		R160	1-216-065-00	METAL GLAZE 4.7K 5%	1/10W
Q209	8-729-255-12	TRANSISTOR 2SC2551-0		R161	1-216-089-00	METAL GLAZE 47K 5%	1/10W
Q210	8-729-255-12	TRANSISTOR 2SC2551-0		R163	1-216-073-00	METAL GLAZE 10K 5%	1/10W
Q211	8-729-255-12	TRANSISTOR 2SC2551-0		R164	1-216-677-11	METAL CHIP 12K 0.50%	1/10W
Q212	8-729-109-44	TRANSISTOR 2SK94-X4		R165	1-216-107-00	METAL GLAZE 270K 5%	1/10W
Q299	8-729-920-74	TRANSISTOR 2SC2412K-QR		R166	1-216-681-11	METAL CHIP 18K 0.50%	1/10W
		<RESISTOR>		R167	1-216-635-11	METAL CHIP 220 0.50%	1/10W
JR105	1-216-295-00	METAL GLAZE 0 5%	1/10W	R168	1-216-103-00	METAL GLAZE 180K 5%	1/10W
JR110	1-216-295-00	METAL GLAZE 0 5%	1/10W	R169	1-216-033-00	METAL GLAZE 220 5%	1/10W
JR118	1-216-295-00	METAL GLAZE 0 5%	1/10W	R170	1-216-089-00	METAL GLAZE 47K 5%	1/10W
JR133	1-216-295-00	METAL GLAZE 0 5%	1/10W	R171	1-216-053-00	METAL GLAZE 1.5K 5%	1/10W
JR138	1-216-295-00	METAL GLAZE 0 5%	1/10W	R172	1-216-043-00	METAL GLAZE 560 5%	1/10W
JR178	1-216-295-00	METAL GLAZE 0 5%	1/10W	R173	1-216-093-00	METAL GLAZE 68K 5%	1/10W
R101	1-216-089-00	METAL GLAZE 47K 5%	1/10W	R174	1-216-069-00	METAL GLAZE 6.8K 5%	1/10W
R102	1-216-025-00	METAL GLAZE 100 5%	1/10W	R175	1-216-057-00	METAL GLAZE 2.2K 5%	1/10W
R103	1-216-091-00	METAL GLAZE 56K 5%	1/10W	R176	1-216-065-00	METAL GLAZE 4.7K 5%	1/10W
R104	1-216-061-00	METAL GLAZE 3.3K 5%	1/10W	R177	1-216-073-00	METAL GLAZE 10K 5%	1/10W
R105	1-216-025-00	METAL GLAZE 100 5%	1/10W	R178	1-216-089-00	METAL GLAZE 47K 5%	1/10W
R106	1-216-065-00	METAL GLAZE 4.7K 5%	1/10W	R179	1-216-081-00	METAL GLAZE 22K 5%	1/10W
R107	1-216-025-00	METAL GLAZE 100 5%	1/10W	R180	1-216-679-11	METAL CHIP 15K 0.50%	1/10W
R108	1-216-113-00	METAL GLAZE 470K 5%	1/10W	R181	1-216-071-00	METAL GLAZE 8.2K 5%	1/10W
R109	1-216-065-00	METAL GLAZE 4.7K 5%	1/10W	R182	1-216-683-11	METAL CHIP 22K 0.50%	1/10W
R110	1-216-049-00	METAL GLAZE 1K 5%	1/10W	R183	1-216-691-11	METAL CHIP 47K 0.50%	1/10W
R111	1-216-063-00	METAL GLAZE 3.9K 5%	1/10W	R184	1-216-699-11	METAL CHIP 100K 0.50%	1/10W
R112	1-216-049-00	METAL GLAZE 1K 5%	1/10W	R185	1-216-073-00	METAL GLAZE 10K 5%	1/10W
R113	1-249-401-11	CARBON 47 5%	1/4W F	R186	1-216-113-00	METAL GLAZE 470K 5%	1/10W
R114	1-216-045-00	METAL GLAZE 680 5%	1/10W	R187	1-216-073-00	METAL GLAZE 10K 5%	1/10W
R115	1-216-061-00	METAL GLAZE 3.3K 5%	1/10W	R188	1-216-113-00	METAL GLAZE 470K 5%	1/10W
R117	1-216-073-00	METAL GLAZE 10K 5%	1/10W	R189	1-216-103-00	METAL GLAZE 180K 5%	1/10W
R118	1-216-025-00	METAL GLAZE 100 5%	1/10W	R190	1-216-107-00	METAL GLAZE 270K 5%	1/10W
R119	1-216-647-11	METAL CHIP 680 0.50%	1/10W	R191	1-216-097-00	METAL GLAZE 100K 5%	1/10W
R120	1-216-647-11	METAL CHIP 680 0.50%	1/10W	R192	1-216-103-00	METAL GLAZE 180K 5%	1/10W
R121	1-216-025-00	METAL GLAZE 100 5%	1/10W	R193	1-216-105-00	METAL GLAZE 220K 5%	1/10W
R122	1-216-083-00	METAL GLAZE 27K 5%	1/10W	R194	1-216-089-00	METAL GLAZE 47K 5%	1/10W
R123	1-216-073-00	METAL GLAZE 10K 5%	1/10W	R195	1-216-113-00	METAL GLAZE 470K 5%	1/10W
R124	1-216-073-00	METAL GLAZE 10K 5%	1/10W	R196	1-216-073-00	METAL GLAZE 10K 5%	1/10W
R125	1-216-083-00	METAL GLAZE 27K 5%	1/10W	R197	1-216-671-11	METAL CHIP 6.8K 0.50%	1/10W
R126	1-216-093-00	METAL GLAZE 68K 5%	1/10W	R198	1-216-049-00	METAL GLAZE 1K 5%	1/10W
R127	1-216-037-00	METAL GLAZE 330 5%	1/10W	R199	1-216-065-00	METAL GLAZE 4.7K 5%	1/10W
R128	1-216-083-00	METAL GLAZE 27K 5%	1/10W	R200	1-216-065-00	METAL GLAZE 4.7K 5%	1/10W
R129	1-216-067-00	METAL GLAZE 5.6K 5%	1/10W	R201	1-216-043-00	METAL GLAZE 560 5%	1/10W
R130	1-216-097-00	METAL GLAZE 100K 5%	1/10W	R202	1-216-033-00	METAL GLAZE 220 5%	1/10W
R131	1-216-089-00	METAL GLAZE 47K 5%	1/10W	R203	1-216-045-00	METAL GLAZE 680 5%	1/10W
R132	1-216-057-00	METAL GLAZE 2.2K 5%	1/10W	R204	1-216-073-00	METAL GLAZE 10K 5%	1/10W
R133	1-216-079-00	METAL GLAZE 18K 5%	1/10W	R205	1-216-073-00	METAL GLAZE 10K 5%	1/10W
R134	1-216-645-11	METAL CHIP 560 0.50%	1/10W	R206	1-216-043-00	METAL GLAZE 560 5%	1/10W
R135	1-216-645-11	METAL CHIP 560 0.50%	1/10W	R207	1-216-045-00	METAL GLAZE 680 5%	1/10W
R136	1-216-091-00	METAL GLAZE 56K 5%	1/10W	R208	1-216-671-11	METAL CHIP 6.8K 0.50%	1/10W
R137	1-216-045-00	METAL GLAZE 680 5%	1/10W	R209	1-216-043-00	METAL GLAZE 560 5%	1/10W
R138	1-216-657-11	METAL CHIP 1.8K 0.50%	1/10W	R210	1-216-033-00	METAL GLAZE 220 5%	1/10W
R139	1-216-079-00	METAL GLAZE 18K 5%	1/10W	R211	1-216-099-00	METAL GLAZE 120K 5%	1/10W
R140	1-216-653-11	METAL CHIP 1.2K 0.50%	1/10W	R212	1-216-065-00	METAL GLAZE 4.7K 5%	1/10W
				R213	1-216-043-00	METAL GLAZE 560 5%	1/10W

B

REF. NO.	PART NO.	DESCRIPTION	REMARK	REF. NO.	PART NO.	DESCRIPTION	REMARK
R214	1-216-043-00	METAL GLAZE	560 5% 1/10W	R280	1-216-061-00	METAL GLAZE	3.3K 5% 1/10W
R215	1-216-125-00	METAL GLAZE	1.5M 5% 1/10W	R281	1-216-061-00	METAL GLAZE	3.3K 5% 1/10W
R216	1-216-043-00	METAL GLAZE	560 5% 1/10W	R282	1-216-037-00	METAL GLAZE	330 5% 1/10W
R217	1-216-033-00	METAL GLAZE	220 5% 1/10W	R283	1-216-049-00	METAL GLAZE	1K 5% 1/10W
R218	1-216-295-00	METAL GLAZE	0 5% 1/10W	R284	1-216-057-00	METAL GLAZE	2.2K 5% 1/10W
R219	1-216-043-00	METAL GLAZE	560 5% 1/10W	R285	1-216-037-00	METAL GLAZE	330 5% 1/10W
R220	1-216-043-00	METAL GLAZE	560 5% 1/10W	R286	1-216-061-00	METAL GLAZE	3.3K 5% 1/10W
R221	1-216-035-00	METAL GLAZE	270 5% 1/10W	R287	1-216-061-00	METAL GLAZE	3.3K 5% 1/10W
R222	1-216-033-00	METAL GLAZE	220 5% 1/10W	R288	1-216-037-00	METAL GLAZE	330 5% 1/10W
R223	1-216-073-00	METAL GLAZE	10K 5% 1/10W	R289	1-216-049-00	METAL GLAZE	1K 5% 1/10W
R224	1-216-073-00	METAL GLAZE	10K 5% 1/10W	R290	1-216-057-00	METAL GLAZE	2.2K 5% 1/10W
R225	1-216-095-00	METAL GLAZE	82K 5% 1/10W	R291	1-216-037-00	METAL GLAZE	330 5% 1/10W
R226	1-216-073-00	METAL GLAZE	10K 5% 1/10W	R292	1-216-061-00	METAL GLAZE	3.3K 5% 1/10W
R227	1-216-035-00	METAL GLAZE	270 5% 1/10W	R293	1-216-061-00	METAL GLAZE	3.3K 5% 1/10W
R228	1-216-065-00	METAL GLAZE	4.7K 5% 1/10W	R295	1-216-057-00	METAL GLAZE	2.2K 5% 1/10W
R229	1-216-113-00	METAL GLAZE	470K 5% 1/10W	R296	1-216-659-11	METAL CHIP	2.2K 0.50% 1/10W
R230	1-216-081-00	METAL GLAZE	22K 5% 1/10W	R297	1-216-659-11	METAL CHIP	2.2K 0.50% 1/10W
R231	1-216-113-00	METAL GLAZE	470K 5% 1/10W	R298	1-216-065-00	METAL GLAZE	4.7K 5% 1/10W
R232	1-216-105-00	METAL GLAZE	220K 5% 1/10W	R300	1-216-065-00	METAL GLAZE	4.7K 5% 1/10W
R233	1-216-073-00	METAL GLAZE	10K 5% 1/10W	R301	1-216-065-00	METAL GLAZE	4.7K 5% 1/10W
R234	1-216-041-00	METAL GLAZE	470 5% 1/10W	R302	1-216-113-00	METAL GLAZE	470K 5% 1/10W
R235	1-216-041-00	METAL GLAZE	470 5% 1/10W	R303	1-216-065-00	METAL GLAZE	4.7K 5% 1/10W
R236	1-216-077-00	METAL GLAZE	15K 5% 1/10W	R304	1-216-049-00	METAL GLAZE	1K 5% 1/10W
R237	1-216-025-00	METAL GLAZE	100 5% 1/10W	R305	1-216-049-00	METAL GLAZE	1K 5% 1/10W
R238	1-216-065-00	METAL GLAZE	4.7K 5% 1/10W	R306	1-216-089-00	METAL GLAZE	47K 5% 1/10W
R239	1-216-065-00	METAL GLAZE	4.7K 5% 1/10W	R307	1-216-033-00	METAL GLAZE	220 5% 1/10W
R240	1-216-033-00	METAL GLAZE	220 5% 1/10W	R308	1-216-089-00	METAL GLAZE	47K 5% 1/10W
R241	1-216-073-00	METAL GLAZE	10K 5% 1/10W	R309	1-216-089-00	METAL GLAZE	47K 5% 1/10W
R242	1-216-051-00	METAL GLAZE	1.2K 5% 1/10W	R310	1-216-033-00	METAL GLAZE	220 5% 1/10W
R243	1-216-113-00	METAL GLAZE	470K 5% 1/10W	R311	1-216-089-00	METAL GLAZE	47K 5% 1/10W
R244	1-216-065-00	METAL GLAZE	4.7K 5% 1/10W	R312	1-216-089-00	METAL GLAZE	47K 5% 1/10W
R245	1-216-679-11	METAL CHIP	15K 0.50% 1/10W	R313	1-216-033-00	METAL GLAZE	220 5% 1/10W
R246	1-216-103-00	METAL GLAZE	180K 5% 1/10W	R314	1-216-089-00	METAL GLAZE	47K 5% 1/10W
R247	1-216-093-00	METAL GLAZE	68K 5% 1/10W	R315	1-216-113-00	METAL GLAZE	470K 5% 1/10W
R248	1-216-095-00	METAL GLAZE	82K 5% 1/10W	R316	1-216-105-00	METAL GLAZE	220K 5% 1/10W
R249	1-216-109-00	METAL GLAZE	330K 5% 1/10W	R317	1-216-109-00	METAL GLAZE	330K 5% 1/10W
R250	1-216-101-00	METAL GLAZE	150K 5% 1/10W	R318	1-216-105-00	METAL GLAZE	220K 5% 1/10W
R251	1-216-105-00	METAL GLAZE	220K 5% 1/10W	R319	1-216-099-00	METAL GLAZE	120K 5% 1/10W
R252	1-216-101-00	METAL GLAZE	150K 5% 1/10W	R320	1-216-099-00	METAL GLAZE	120K 5% 1/10W
R253	1-216-101-00	METAL GLAZE	150K 5% 1/10W	R321	1-216-043-00	METAL GLAZE	560 5% 1/10W
R254	1-216-033-00	METAL GLAZE	220 5% 1/10W	R322	1-216-109-00	METAL GLAZE	330K 5% 1/10W
R255	1-216-061-00	METAL GLAZE	3.3K 5% 1/10W	R323	1-216-109-00	METAL GLAZE	330K 5% 1/10W
R256	1-216-107-00	METAL GLAZE	270K 5% 1/10W	R324	1-216-109-00	METAL GLAZE	330K 5% 1/10W
R258	1-216-041-00	METAL GLAZE	470 5% 1/10W	R325	1-216-097-00	METAL GLAZE	100K 5% 1/10W
R259	1-216-073-00	METAL GLAZE	10K 5% 1/10W	R326	1-216-113-00	METAL GLAZE	470K 5% 1/10W
R260	1-216-025-00	METAL GLAZE	100 5% 1/10W	R328	1-216-073-00	METAL GLAZE	10K 5% 1/10W
R261	1-216-035-00	METAL GLAZE	270 5% 1/10W	R329	1-216-107-00	METAL GLAZE	270K 5% 1/10W
R262	1-216-097-00	METAL GLAZE	100K 5% 1/10W	R330	1-216-105-00	METAL GLAZE	220K 5% 1/10W
R263	1-216-029-00	METAL GLAZE	150 5% 1/10W	R331	1-216-025-00	METAL GLAZE	100 5% 1/10W
R264	1-216-065-00	METAL GLAZE	4.7K 5% 1/10W	R332	1-216-097-00	METAL GLAZE	100K 5% 1/10W
R265	1-216-067-00	METAL GLAZE	5.6K 5% 1/10W	R333	1-216-097-00	METAL GLAZE	100K 5% 1/10W
R266	1-216-073-00	METAL GLAZE	10K 5% 1/10W	R334	1-216-025-00	METAL GLAZE	100 5% 1/10W
R267	1-216-073-00	METAL GLAZE	10K 5% 1/10W	R335	1-216-099-00	METAL GLAZE	120K 5% 1/10W
R268	1-216-081-00	METAL GLAZE	22K 5% 1/10W	R336	1-216-095-00	METAL GLAZE	82K 5% 1/10W
R269	1-216-101-00	METAL GLAZE	150K 5% 1/10W	R337	1-216-105-00	METAL GLAZE	220K 5% 1/10W
R270	1-216-081-00	METAL GLAZE	22K 5% 1/10W	R338	1-216-025-00	METAL GLAZE	100 5% 1/10W
R271	1-216-025-00	METAL GLAZE	100 5% 1/10W	R339	1-216-099-00	METAL GLAZE	120K 5% 1/10W
R272	1-216-101-00	METAL GLAZE	150K 5% 1/10W	R340	1-216-095-00	METAL GLAZE	82K 5% 1/10W
R273	1-216-113-00	METAL GLAZE	470K 5% 1/10W	R341	1-216-105-00	METAL GLAZE	220K 5% 1/10W
R275	1-216-081-00	METAL GLAZE	22K 5% 1/10W	R342	1-216-047-00	METAL GLAZE	820 5% 1/10W
R276	1-216-037-00	METAL GLAZE	330 5% 1/10W	R343	1-216-053-00	METAL GLAZE	1.5K 5% 1/10W
R277	1-216-049-00	METAL GLAZE	1K 5% 1/10W				
R278	1-216-057-00	METAL GLAZE	2.2K 5% 1/10W				
R279	1-216-037-00	METAL GLAZE	330 5% 1/10W				



Les composants identifiés par une trame et une marque Δ sont critiques pour la sécurité. Ne les remplacer que par une pièce portant le numéro spécifié.

The components identified by shading and mark Δ are critical for safety. Replace only with part number specified.

REF. NO.	PART NO.	DESCRIPTION	REMARK
<MODULE>			
SEP101	1-808-654-11	MODULE	
<CRYSTAL>			
X101	1-527-722-00	OSCILLATOR, CRYSTAL	
X102	1-577-259-11	VIBRATOR, CRYSTAL	

*A-1195-048-A P BOARD, COMPLETE			

<CAPACITOR>			
C801	1-126-104-11	ELECT	470MF 20% 35V
C802	1-162-318-11	CERAMIC	0.001MF 10% 500V
C803	1-102-228-00	CERAMIC	470PF 10% 500V
C804	1-123-935-00	ELECT	33MF 20% 160V
C805	1-101-004-00	CERAMIC	0.01MF 50V
C806	1-124-480-11	ELECT	470MF 20% 25V
C807	1-102-228-00	CERAMIC	470PF 10% 500V
C808	1-106-367-00	MYLAR	0.01MF 10% 100V
C809	1-106-375-12	MYLAR	0.022MF 10% 100V
C810	1-162-318-11	CERAMIC	0.001MF 10% 500V
C811 Δ	1-137-544-91	FILM	0.01MF 3% 600V
C812 Δ	1-137-545-91	FILM	0.013MF 3% 600V
C813	1-106-385-00	MYLAR	0.056MF 5% 200V
C814	1-106-383-00	MYLAR	0.047MF 10% 100V
C815	1-126-233-11	ELECT	22MF 20% 50V
C816	1-124-798-11	ELECT	1MF 20% 160V
C817	1-130-800-00	FILM	2.2MF 10% 250V
C818	1-102-228-00	CERAMIC	470PF 10% 500V
C819	1-162-116-00	CERAMIC	680PF 10% 2KV
C820	1-162-116-00	CERAMIC	680PF 10% 2KV
<CONNECTOR>			
CN801	*1-564-595-11	PLUG, CONNECTOR 14P	
CN802	*1-508-766-00	PIN, CONNECTOR (5MM PITCH) 4P	
CN803	*1-564-508-11	PLUG, CONNECTOR 5P	
CN805	*1-560-123-00	PLUG, CONNECTOR (2.5MM) 3P	
<DIODE>			
D801	8-719-300-33	DIODE RU-3AM	
D802	8-719-300-33	DIODE RU-3AM	
D803	8-719-300-33	DIODE RU-3AM	
D804	8-719-979-85	DIODE EGP-20G	
D805	8-719-300-33	DIODE RU-3AM	
D806	8-719-300-33	DIODE RU-3AM	
D807	8-719-105-99	DIODE RD6.2M-B1	
D808	8-719-008-28	THYRISTOR CRO.2AM-8	
D809	8-719-911-55	DIODE U05G	
D810	8-719-911-55	DIODE U05G	
D811	8-719-911-55	DIODE U05G	
D813	8-719-300-33	DIODE RU-3AM	
<COIL>			
L802	1-459-442-00	COIL (WITH CORE)	
L803	1-422-613-11	COIL, AIR CORE	
L804	1-459-109-00	COIL, DUST CORE	
L805 Δ	1-460-225-11	COIL, HORIZONTAL LINEARITY	
L806	1-407-500-00	INDUCTOR 4.7MMH	
L807	1-407-500-00	INDUCTOR 4.7MMH	

REF. NO.	PART NO.	DESCRIPTION	REMARK
<NEON LAMP>			
NL801	1-519-108-XX	LAMP, NEON	
<TRANSISTOR>			
Q801	8-729-195-82	TRANSISTOR 2SC2958-L	
Q802	8-729-201-62	TRANSISTOR 2SC2555-2	
*4-363-404-00 HOLDER, IC; Q802			
4-382-854-01 SCREW (M3X8), P. SW (+); Q802			
4-879-937-00 SHEET, MICA; Q802			
Q803	8-729-906-24	TRANSISTOR 2SD835	
<RESISTOR>			
R801	1-249-383-11	CARBON	1.5 5% 1/4W F
R802	1-249-377-11	CARBON	0.47 5% 1/4W F
R803	1-216-049-00	METAL GLAZE	1K 5% 1/10W
R804	1-249-419-11	CARBON	1.5K 5% 1/4W F
R805	1-215-892-11	METAL OXIDE	1K 5% 2W F
R807	1-216-425-11	METAL OXIDE	56 5% 1W F
R808	1-202-881-91	SOLID	470K 20% 1/2W
R809	1-216-089-00	METAL GLAZE	47K 5% 1/10W
R810	1-249-421-11	CARBON	2.2K 5% 1/4W F
R811	1-216-049-00	METAL GLAZE	1K 5% 1/10W
R812	1-249-439-11	CARBON	68K 5% 1/4W F
R813	1-249-414-11	CARBON	560 5% 1/4W F
R814	1-249-377-11	CARBON	0.47 5% 1/4W F
<VARIABLE RESISTOR>			
RV801	1-223-102-00	RES, ADJ, WIREWOUND 120	
<TRANSFORMER>			
T801	1-437-082-31	HDT	
T802 Δ	1-439-526-11	TRANSFORMER ASSY, FLYBACK	

*1-641-723-11 FA BOARD			

*4-341-751-01 EYELET EY6, EY7			
*4-341-752-01 EYELET EY1, EY3, EY8, EY9			
<CONNECTOR>			
CN601	*1-580-689-11	PIN, CONNECTOR (PC BOARD) 4P	
CN602	*1-508-765-00	PIN, CONNECTOR (5MM PITCH) 3P	
CN603	*1-564-507-11	PLUG, CONNECTOR 4P	
<FUSE>			
F601 Δ	1-532-745-11	FUSE, GLASS TUBE (3.15A/125V)	
	1-533-223-11	CLIP, FUSE; F601	
<RESISTOR>			
R602	1-202-721-00	SOLID	1.5M 10% 1/2W
<SWITCH>			



REF. NO.	PART NO.	DESCRIPTION	REMARK
S601	1-692-049-11	SWITCH, PUSH (AC POWER) (1KEY)	

A-1275-099-A		QA BOARD, COMPLETE	

1-537-408-11		TERMINAL BOARD, INPUT/OUTPUT (LINE B)	
1-537-410-11		TERMINAL BOARD, INPUT/OUTPUT (LINE A)	
*4-341-752-01		EYELET EY10, EY11	
<CAPACITOR>			
C401	1-124-234-00	ELECT 22MF	20% 16V
C402	1-124-234-00	ELECT 22MF	20% 16V
C403	1-124-234-00	ELECT 22MF	20% 16V
C404	1-124-234-00	ELECT 22MF	20% 16V
C405	1-124-234-00	ELECT 22MF	20% 16V
C406	1-124-234-00	ELECT 22MF	20% 16V
C407	1-124-234-00	ELECT 22MF	20% 16V
C408	1-124-463-00	ELECT 0.1MF	20% 50V
C409	1-124-234-00	ELECT 22MF	20% 16V
C410	1-124-234-00	ELECT 22MF	20% 16V
C411	1-124-234-00	ELECT 22MF	20% 16V
C412	1-124-234-00	ELECT 22MF	20% 16V
C413	1-124-234-00	ELECT 22MF	20% 16V
C414	1-126-157-11	ELECT 10MF	20% 16V
C415	1-126-157-11	ELECT 10MF	20% 16V
C416	1-126-157-11	ELECT 10MF	20% 16V
C417	1-126-157-11	ELECT 10MF	20% 16V
C418	1-126-157-11	ELECT 10MF	20% 16V
C419	1-126-157-11	ELECT 10MF	20% 16V
C420	1-126-157-11	ELECT 10MF	20% 16V
C421	1-102-125-00	CERAMIC 0.0047MF	10% 50V
C422	1-124-464-11	ELECT 0.22MF	20% 50V
C423	1-126-157-11	ELECT 10MF	20% 16V
C424	1-126-157-11	ELECT 10MF	20% 16V
C425	1-108-634-11	MYLAR 0.047MF	10% 100V
C426	1-128-499-61	ELECT 220MF	20% 16V
C427	1-128-499-61	ELECT 220MF	20% 16V
C428	1-124-589-11	ELECT 47MF	20% 16V
C429	1-124-234-00	ELECT 22MF	20% 16V
C430	1-163-033-00	CERAMIC CHIP 0.022MF	50V
C431	1-124-234-00	ELECT 22MF	20% 16V
C432	1-163-033-00	CERAMIC CHIP 0.022MF	50V
C433	1-124-234-00	ELECT 22MF	20% 16V
C434	1-163-033-00	CERAMIC CHIP 0.022MF	50V
C435	1-124-234-00	ELECT 22MF	20% 16V
C436	1-163-033-00	CERAMIC CHIP 0.022MF	50V
C437	1-163-033-00	CERAMIC CHIP 0.022MF	50V
C438	1-124-234-00	ELECT 22MF	20% 16V
C439	1-163-033-00	CERAMIC CHIP 0.022MF	50V
C440	1-163-033-00	CERAMIC CHIP 0.022MF	50V
C441	1-124-234-00	ELECT 22MF	20% 16V
C442	1-163-033-00	CERAMIC CHIP 0.022MF	50V
C443	1-163-033-00	CERAMIC CHIP 0.022MF	50V
C444	1-163-033-00	CERAMIC CHIP 0.022MF	50V
C445	1-163-031-11	CERAMIC CHIP 0.01MF	50V
C446	1-163-031-11	CERAMIC CHIP 0.01MF	50V
C447	1-126-301-11	ELECT 1MF	20% 50V
C448	1-124-234-00	ELECT 22MF	20% 16V
C449	1-163-031-11	CERAMIC CHIP 0.01MF	50V
C450	1-124-234-00	ELECT 22MF	20% 16V
C451	1-163-033-00	CERAMIC CHIP 0.022MF	50V
C452	1-128-499-61	ELECT 220MF	20% 16V

REF. NO.	PART NO.	DESCRIPTION	REMARK
C453	1-124-234-00	ELECT 22MF	20% 16V
C454	1-128-499-61	ELECT 220MF	20% 16V
C460	1-126-301-11	ELECT 1MF	20% 50V
C461	1-126-301-11	ELECT 1MF	20% 50V
C462	1-126-301-11	ELECT 1MF	20% 50V
C464	1-163-031-11	CERAMIC CHIP 0.01MF	50V
C465	1-163-031-11	CERAMIC CHIP 0.01MF	50V
C466	1-163-031-11	CERAMIC CHIP 0.01MF	50V
C467	1-163-031-11	CERAMIC CHIP 0.01MF	50V
<CONNECTOR>			
CN401	1-506-494-11	PIN, CONNECTOR 15P	
CN402	*1-564-518-11	PLUG, CONNECTOR 3P	
CN403	*1-580-690-11	PIN, CONNECTOR (PC BOARD) 4P	
CN404	*1-564-519-11	PLUG, CONNECTOR 4P	
<DIODE>			
D401	8-719-404-46	DIODE MA110	
D402	8-719-404-46	DIODE MA110	
D403	8-719-110-09	DIODE RD8.2ES-B3	
D404	8-719-404-46	DIODE MA110	
D405	8-719-404-46	DIODE MA110	
D406	8-719-404-46	DIODE MA110	
D407	8-719-404-46	DIODE MA110	
D408	8-719-404-46	DIODE MA110	
D409	8-719-404-46	DIODE MA110	
D410	8-719-404-46	DIODE MA110	
D411	8-719-404-46	DIODE MA110	
D412	8-719-404-46	DIODE MA110	
D413	8-719-404-46	DIODE MA110	
D414	8-719-404-46	DIODE MA110	
D415	8-719-404-46	DIODE MA110	
D416	8-719-404-46	DIODE MA110	
D417	8-719-404-46	DIODE MA110	
D418	8-719-404-46	DIODE MA110	
D419	8-719-404-46	DIODE MA110	
D420	8-719-404-46	DIODE MA110	
D421	8-719-404-46	DIODE MA110	
D422	8-719-404-46	DIODE MA110	
D423	8-719-404-46	DIODE MA110	
D424	8-719-404-46	DIODE MA110	
D425	8-719-404-46	DIODE MA110	
D426	8-719-404-46	DIODE MA110	
D427	8-719-404-46	DIODE MA110	
D428	8-719-404-46	DIODE MA110	
D429	8-719-404-46	DIODE MA110	
D430	8-719-404-46	DIODE MA110	
D431	8-719-404-46	DIODE MA110	
<IC>			
IC401	8-759-501-21	IC MM1149XF	
IC402	8-759-501-21	IC MM1149XF	
IC403	8-759-420-04	IC AN5265	
<COIL>			
L401	1-410-682-31	INDUCTOR 470UH	
L402	1-410-682-31	INDUCTOR 470UH	

QA

REF. NO.	PART NO.	DESCRIPTION	REMARK	REF. NO.	PART NO.	DESCRIPTION	REMARK
<TRANSISTOR>							
Q401	8-729-920-74	TRANSISTOR 2SC2412K-QR		R438	1-216-091-00	METAL GLAZE 56K 5%	1/10W
Q402	8-729-920-74	TRANSISTOR 2SC2412K-QR		R439	1-216-063-00	METAL GLAZE 3.9K 5%	1/10W
Q403	8-729-216-22	TRANSISTOR 2SA1162-G		R440	1-216-027-00	METAL GLAZE 120 5%	1/10W
Q404	8-729-920-74	TRANSISTOR 2SC2412K-QR		R441	1-216-089-00	METAL GLAZE 47K 5%	1/10W
Q405	8-729-920-74	TRANSISTOR 2SC2412K-QR		R442	1-216-049-00	METAL GLAZE 1K 5%	1/10W
Q406	8-729-920-74	TRANSISTOR 2SC2412K-QR		R443	1-216-748-11	METAL GLAZE 39K 5%	1/10W
Q407	8-729-920-74	TRANSISTOR 2SC2412K-QR		R444	1-214-702-00	METAL 75 1%	1/4W
Q408	8-729-920-74	TRANSISTOR 2SC2412K-QR		R445	1-216-049-00	METAL GLAZE 1K 5%	1/10W
Q409	8-729-920-74	TRANSISTOR 2SC2412K-QR		R446	1-216-093-00	METAL GLAZE 68K 5%	1/10W
Q410	8-729-920-74	TRANSISTOR 2SC2412K-QR		R447	1-216-091-00	METAL GLAZE 56K 5%	1/10W
Q411	8-729-216-22	TRANSISTOR 2SA1162-G		R448	1-216-063-00	METAL GLAZE 3.9K 5%	1/10W
Q412	8-729-216-22	TRANSISTOR 2SA1162-G		R449	1-216-027-00	METAL GLAZE 120 5%	1/10W
Q413	8-729-216-22	TRANSISTOR 2SA1162-G		R450	1-214-702-00	METAL 75 1%	1/4W
Q414	8-729-216-22	TRANSISTOR 2SA1162-G		R451	1-216-049-00	METAL GLAZE 1K 5%	1/10W
Q416	8-729-145-18	TRANSISTOR 2SC3736		R452	1-216-091-00	METAL GLAZE 56K 5%	1/10W
Q417	8-729-901-06	TRANSISTOR DTA144EK		R453	1-216-093-00	METAL GLAZE 68K 5%	1/10W
Q418	8-729-901-06	TRANSISTOR DTA144EK		R454	1-216-063-00	METAL GLAZE 3.9K 5%	1/10W
Q419	8-729-901-06	TRANSISTOR DTA144EK		R455	1-216-037-00	METAL GLAZE 330 5%	1/10W
Q420	8-729-901-01	TRANSISTOR DTC144EK		R456	1-216-085-00	METAL GLAZE 33K 5%	1/10W
Q421	8-729-901-06	TRANSISTOR DTA144EK		R457	1-216-085-00	METAL GLAZE 33K 5%	1/10W
Q422	8-729-901-01	TRANSISTOR DTC144EK		R458	1-247-707-11	CARBON 390 5%	1/4W
Q423	8-729-901-06	TRANSISTOR DTA144EK		R459	1-216-748-11	METAL GLAZE 39K 5%	1/10W
Q424	8-729-901-06	TRANSISTOR DTA144EK		R460	1-216-089-00	METAL GLAZE 47K 5%	1/10W
<RESISTOR>							
R401	1-214-702-00	METAL	75 1% 1/4W	R461	1-216-097-00	METAL GLAZE 100K 5%	1/10W
R402	1-216-049-00	METAL GLAZE	1K 5% 1/10W	R462	1-216-115-00	METAL GLAZE 560K 5%	1/10W
R403	1-216-093-00	METAL GLAZE	68K 5% 1/10W	R463	1-216-105-00	METAL GLAZE 220K 5%	1/10W
R404	1-216-091-00	METAL GLAZE	56K 5% 1/10W	R464	1-216-077-00	METAL GLAZE 15K 5%	1/10W
R405	1-216-063-00	METAL GLAZE	3.9K 5% 1/10W	R465	1-216-025-00	METAL GLAZE 100 5%	1/10W
R406	1-216-037-00	METAL GLAZE	330 5% 1/10W	R466	1-216-097-00	METAL GLAZE 100K 5%	1/10W
R407	1-216-748-11	METAL GLAZE	39K 5% 1/10W	R467	1-216-115-00	METAL GLAZE 560K 5%	1/10W
R408	1-216-085-00	METAL GLAZE	33K 5% 1/10W	R468	1-216-105-00	METAL GLAZE 220K 5%	1/10W
R409	1-214-702-00	METAL	75 1% 1/4W	R469	1-216-077-00	METAL GLAZE 15K 5%	1/10W
R410	1-216-049-00	METAL GLAZE	1K 5% 1/10W	R470	1-216-025-00	METAL GLAZE 100 5%	1/10W
R411	1-216-093-00	METAL GLAZE	68K 5% 1/10W	R471	1-216-097-00	METAL GLAZE 100K 5%	1/10W
R412	1-216-091-00	METAL GLAZE	56K 5% 1/10W	R472	1-216-115-00	METAL GLAZE 560K 5%	1/10W
R413	1-216-063-00	METAL GLAZE	3.9K 5% 1/10W	R473	1-216-105-00	METAL GLAZE 220K 5%	1/10W
R414	1-216-037-00	METAL GLAZE	330 5% 1/10W	R474	1-216-077-00	METAL GLAZE 15K 5%	1/10W
R415	1-216-061-00	METAL GLAZE	3.3K 5% 1/10W	R475	1-216-025-00	METAL GLAZE 100 5%	1/10W
R416	1-216-023-00	METAL GLAZE	82 5% 1/10W	R477	1-216-081-00	METAL GLAZE 22K 5%	1/10W
R417	1-216-049-00	METAL GLAZE	1K 5% 1/10W	R479	1-216-085-00	METAL GLAZE 33K 5%	1/10W
R418	1-216-093-00	METAL GLAZE	68K 5% 1/10W	R480	1-247-711-11	CARBON 680 5%	1/4W
R419	1-216-091-00	METAL GLAZE	56K 5% 1/10W	R481	1-247-720-11	CARBON 3.9K 5%	1/4W
R420	1-216-063-00	METAL GLAZE	3.9K 5% 1/10W	R482	1-249-455-11	CARBON 4.7 5%	1/4W
R421	1-216-027-00	METAL GLAZE	120 5% 1/10W	R483	1-249-389-11	CARBON 4.7 5%	1/4W F
R422	1-214-702-00	METAL	75 1% 1/4W	R484	1-216-041-00	METAL GLAZE 470 5%	1/10W
R423	1-214-702-00	METAL	75 1% 1/4W	R485	1-247-688-11	CARBON 10 5%	1/4W F
R424	1-216-049-00	METAL GLAZE	1K 5% 1/10W	R486	1-216-037-00	METAL GLAZE 330 5%	1/10W
R425	1-216-093-00	METAL GLAZE	68K 5% 1/10W	R487	1-249-468-11	CARBON 82K 5%	1/4W
R426	1-216-091-00	METAL GLAZE	56K 5% 1/10W	R488	1-249-468-11	CARBON 82K 5%	1/4W
R427	1-216-063-00	METAL GLAZE	3.9K 5% 1/10W	R489	1-249-468-11	CARBON 82K 5%	1/4W
R428	1-216-037-00	METAL GLAZE	330 5% 1/10W	R490	1-216-057-00	METAL GLAZE 2.2K 5%	1/10W
R429	1-214-702-00	METAL	75 1% 1/4W	R491	1-216-089-00	METAL GLAZE 47K 5%	1/10W
R430	1-216-049-00	METAL GLAZE	1K 5% 1/10W	R492	1-216-089-00	METAL GLAZE 47K 5%	1/10W
R431	1-216-093-00	METAL GLAZE	68K 5% 1/10W	R493	1-216-089-00	METAL GLAZE 47K 5%	1/10W
R432	1-216-091-00	METAL GLAZE	56K 5% 1/10W	R494	1-216-089-00	METAL GLAZE 47K 5%	1/10W
R433	1-216-063-00	METAL GLAZE	3.9K 5% 1/10W	R495	1-216-295-00	METAL GLAZE 0 5%	1/10W
R434	1-216-027-00	METAL GLAZE	120 5% 1/10W	R496	1-216-057-00	METAL GLAZE 2.2K 5%	1/10W
R435	1-214-702-00	METAL	75 1% 1/4W	R497	1-216-089-00	METAL GLAZE 47K 5%	1/10W
R436	1-216-049-00	METAL GLAZE	1K 5% 1/10W	R498	1-216-089-00	METAL GLAZE 47K 5%	1/10W
R437	1-216-093-00	METAL GLAZE	68K 5% 1/10W	R499	1-216-089-00	METAL GLAZE 47K 5%	1/10W
				R1401	1-216-097-00	METAL GLAZE 100K 5%	1/10W
				R1403	1-216-295-00	METAL GLAZE 0 5%	1/10W
				R1404	1-216-097-00	METAL GLAZE 100K 5%	1/10W



REF.NO.	PART NO.	DESCRIPTION	REMARK
		<VARIABLE RESISTOR>	
RV401	1-230-481-11	RES, VAR, CARBON 20K	

	*1-641-720-11	CA BOARD	*****
	1-526-958-41	SOCKET, CRT	
		<CAPACITOR>	
C701	1-162-114-00	CERAMIC	0.0047MF 10% 2KV
C702	1-102-050-00	CERAMIC	0.01MF 99% 500V
C710	1-161-830-00	CERAMIC	0.0047MF 99% 500V
		<CONNECTOR>	
CN701	*1-564-509-11	PLUG, CONNECTOR 6P	
CN702	*1-508-784-00	PIN, CONNECTOR (5MM PITCH) 1P	
CN703	*1-564-508-11	PLUG, CONNECTOR 5P	
		<COIL>	
L701	1-410-668-11	INDUCTOR	27UH
		<RESISTOR>	
R701	1-202-871-91	SOLID	2.2K 20% 1/2W
R702	1-202-871-91	SOLID	2.2K 20% 1/2W
R703	1-202-871-91	SOLID	2.2K 20% 1/2W
R704	1-202-877-91	SOLID	100K 20% 1/2W
R705	1-202-885-91	SOLID	1M 20% 1/2W
R706	1-202-878-91	SOLID	220K 20% 1/2W
		<VARIABLE RESISTOR>	
RV701	1-230-164-00	RES, ADJ, METAL GLAZE 55M	
	*4-376-132-11	COVER (REAR LID), CV VOL; RV701	
	*4-376-133-11	COVER (MAIN), CV VOL; RV701	

	A-1346-018-A	D BOARD, COMPLETE	*****
	1-533-189-11	HOLDER, FUSE	
	3-710-578-01	COVER, VOLUME, 6 MOLD	
	*3-738-015-01	COVER, (DIA. 6) CARBON VR	
	4-382-854-01	SCREW (M3X8), P, SW (+)	
	4-382-854-11	SCREW (M3X10), P, SW (+)	
		<CAPACITOR>	
C501	1-124-477-11	ELECT	47MF 20% 16V
C502	1-124-907-11	ELECT	10MF 20% 50V
C503	1-126-103-11	ELECT	470MF 20% 16V
C504	1-124-902-00	ELECT	0.47MF 20% 50V
C505	1-106-381-12	MYLAR	0.039MF 10% 100V
C506	1-124-903-11	ELECT	1MF 20% 50V
C507	1-106-367-00	MYLAR	0.01MF 10% 100V
C508	1-124-903-11	ELECT	1MF 20% 50V
C509	1-136-173-00	FILM	0.47MF 5% 50V
C510	1-136-161-00	FILM	0.047MF 5% 50V
C511	1-124-903-11	ELECT	1MF 20% 50V

REF.NO.	PART NO.	DESCRIPTION	REMARK
C512	1-106-375-12	MYLAR	0.022MF 10% 100V
C513	1-106-375-12	MYLAR	0.022MF 10% 100V
C514	1-106-371-00	MYLAR	0.015MF 10% 100V
C515	1-124-925-11	ELECT	2.2MF 20% 50V
C516	1-124-925-11	ELECT	2.2MF 20% 50V
C517	1-130-480-00	FILM	0.0056MF 5% 50V
C518	1-163-245-11	CERAMIC CHIP	56PF 5% 50V
C519	1-124-927-11	ELECT	4.7MF 20% 50V
C520	1-163-129-00	CERAMIC CHIP	330PF 5% 50V
C521	1-124-907-11	ELECT	10MF 20% 50V
C523	1-106-363-00	MYLAR	0.0068MF 10% 100V
C524	1-102-116-00	CERAMIC	680PF 10% 50V
C525	1-102-820-00	CERAMIC	330PF 5% 50V
C526	1-102-973-00	CERAMIC	100PF 5% 50V
C527	1-124-122-11	ELECT	100MF 20% 50V
C528	1-102-125-00	CERAMIC	0.0047MF 10% 50V
C529	1-124-910-11	ELECT	47MF 20% 50V
C530	1-163-097-00	CERAMIC CHIP	15PF 5% 50V
C531	1-131-370-00	TANTALUM	6.8MF 10% 16V
C532	1-124-557-11	ELECT	1000MF 20% 25V
C533	1-124-927-11	ELECT	4.7MF 20% 50V
C534	1-124-768-11	ELECT	4.7MF 20% 50V
C535	1-136-161-00	FILM	0.047MF 5% 50V
C536	1-124-927-11	ELECT	4.7MF 20% 50V
C537	1-124-484-11	ELECT	220MF 20% 35V
C538	1-124-910-11	ELECT	47MF 20% 50V
C539	1-136-113-00	FILM	2MF 5% 200V
C540	1-163-017-00	CERAMIC CHIP	0.0047MF 10% 50V
C541	1-163-035-00	CERAMIC CHIP	0.047MF 50V
C542	1-126-103-11	ELECT	470MF 20% 16V
C545	1-126-101-11	ELECT	100MF 20% 16V
C546	1-124-907-11	ELECT	10MF 20% 50V
C547	1-124-907-11	ELECT	10MF 20% 50V
C548	1-124-907-11	ELECT	10MF 20% 50V
C549	1-124-907-11	ELECT	10MF 20% 50V
C550	1-124-907-11	ELECT	10MF 20% 50V
C551	1-124-927-11	ELECT	4.7MF 20% 50V
C552	1-101-004-00	CERAMIC	0.01MF 50V
C553	1-126-103-11	ELECT	470MF 20% 16V
C563	1-106-383-00	MYLAR	0.047MF 10% 100V
C564	1-162-318-11	CERAMIC	0.001MF 10% 500V
C567	1-124-907-11	ELECT	10MF 20% 50V
C568	1-130-736-11	FILM	0.01MF 5% 50V
C569	1-130-471-00	FILM	0.001MF 5% 50V
C570	1-163-117-00	CERAMIC CHIP	100PF 5% 50V
C571	1-124-913-11	ELECT	470MF 20% 50V
C572	1-101-004-00	CERAMIC	0.01MF 50V
C574	1-106-351-00	MYLAR	0.0022MF 10% 100V
C575	1-106-351-00	MYLAR	0.0022MF 10% 100V
C831	1-124-907-11	ELECT	10MF 20% 50V
C832	1-124-907-11	ELECT	10MF 20% 50V
C833	1-163-009-11	CERAMIC CHIP	0.001MF 10% 50V
C834	1-163-121-00	CERAMIC CHIP	150PF 5% 50V
C835	1-163-209-00	CERAMIC CHIP	0.0015MF 5% 50V
C836	1-124-907-11	ELECT	10MF 20% 50V
C837	1-106-347-00	MYLAR	0.0015MF 10% 100V
C838	1-136-163-00	FILM	0.068MF 5% 50V
C839	1-106-351-00	MYLAR	0.0022MF 10% 100V
C840	1-163-209-00	CERAMIC CHIP	0.0015MF 5% 50V
C841	1-163-209-00	CERAMIC CHIP	0.0015MF 5% 50V
C843	1-124-902-00	ELECT	0.47MF 20% 50V
C844	1-124-902-00	ELECT	0.47MF 20% 50V
C845	1-124-477-11	ELECT	47MF 20% 25V
C846	1-124-907-11	ELECT	10MF 20% 50V
C847	1-126-233-11	ELECT	22MF 20% 50V

D

Les composants identifiés par une trame et une marque Δ sont critiques pour la sécurité. Ne les remplacer que par une pièce portant le numéro spécifié.

The components identified by shading and mark Δ are critical for safety. Replace only with part number specified.

REF. NO.	PART NO.	DESCRIPTION	REMARK	REF. NO.	PART NO.	DESCRIPTION	REMARK
C848	1-131-351-00	TANTALUM 4.7MF	10%	D1612	8-719-404-46	DIODE MA110	
C849	1-164-182-11	CERAMIC CHIP 0.0033MF	10%	D1613	8-719-404-46	DIODE MA110	
C1601	1-124-907-11	ELECT 10MF	20%	D1614	8-719-404-46	DIODE MA110	
C1602	1-164-161-11	CERAMIC CHIP 0.0022MF	10%	D1615	8-719-404-46	DIODE MA110	
C1603	1-124-903-11	ELECT 1MF	20%	D1616	8-719-404-46	DIODE MA110	
C1604	1-128-500-51	ELECT 1000MF	20%	D1617	8-719-977-49	DIODE DTZ15B	
C1605	1-124-922-11	ELECT 1000MF	20%	D1618	8-719-977-49	DIODE DTZ15B	
C1606	1-102-074-00	CERAMIC 0.001MF	10%	D1621	8-719-510-12	DIODE D10SC4M	
C1607	1-124-907-11	ELECT 10MF	20%	D1625	8-719-404-46	DIODE MA110	
C1608	1-126-233-11	ELECT 22MF	20%	D1626	8-719-404-46	DIODE MA110	
C1609	1-163-009-11	CERAMIC CHIP 0.001MF	10%	D1627	8-719-404-46	DIODE MA110	
C1610	1-124-927-11	ELECT 4.7MF	20%	D1628	8-719-404-46	DIODE MA110	
C1611	1-126-233-11	ELECT 22MF	20%	D1635	8-719-404-46	DIODE MA110	
C1612	1-130-025-91	FILM 0.0039MF	5%	D1699	8-719-404-46	DIODE MA110	
C1613	1-163-009-11	CERAMIC CHIP 0.001MF	10%				
C1614	1-164-232-11	CERAMIC CHIP 0.01MF	10%				
C1615	1-124-465-00	ELECT 0.47MF	20%			<FUSE>	
C1620	1-163-133-00	CERAMIC CHIP 470PF	5%				
C1621	1-163-117-00	CERAMIC CHIP 100PF	5%				
		<CONNECTOR>					
CN501	*1-564-506-11	PLUG, CONNECTOR 3P					
CN502	1-506-477-11	PIN, CONNECTOR 12P					
CN504	*1-564-507-11	PLUG, CONNECTOR 4P					
CN505	*1-564-509-11	PLUG, CONNECTOR 6P					
CN507	*1-564-511-11	PLUG, CONNECTOR 8P					
CN508	*1-564-104-00	PIN, CONNECTOR (B3P-VH) 3P					
CN509	*1-564-506-11	PLUG, CONNECTOR 3P					
		<DIODE>					
D501	8-719-404-46	DIODE MA110					
D502	8-719-404-46	DIODE MA110					
D503	8-719-404-46	DIODE MA110					
D504	8-719-404-46	DIODE MA110					
D505	8-719-404-46	DIODE MA110					
D506	8-719-911-55	DIODE U05G					
D507	8-719-404-46	DIODE MA110					
D508	8-719-404-46	DIODE MA110					
D509	8-719-404-46	DIODE MA110					
D510	8-719-404-46	DIODE MA110					
D511	8-719-404-46	DIODE MA110					
D512	8-719-404-46	DIODE MA110					
D514	8-719-404-46	DIODE MA110					
D831	8-719-404-46	DIODE MA110					
D832	8-719-404-46	DIODE MA110					
D833	8-719-404-46	DIODE MA110					
D834	8-719-404-46	DIODE MA110					
D835	8-719-109-89	DIODE RD5.6ES-B2					
D836	8-719-977-69	DIODE DTZ24B					
D837	8-719-404-46	DIODE MA110					
D838	8-719-404-46	DIODE MA110					
D1601	8-719-105-XX	DIODE RD6.2M-B1					
D1602	8-719-404-46	DIODE MA110					
D1603	8-719-977-61	DIODE DTZ20B					
D1604	8-719-404-46	DIODE MA110					
D1605	8-719-404-46	DIODE MA110					
D1606	8-719-981-00	DIODE ERC81-004					
D1607	8-719-981-00	DIODE ERC81-004					
D1608	8-719-977-02	DIODE DTZ5.6A					
D1609	8-719-977-49	DIODE DTZ15B					
D1610	8-719-404-46	DIODE MA110					
D1611	8-729-101-31	TRANSISTOR N13T1					
		<IC>					
IC501	8-759-909-70	IC CX23025					
IC502	8-759-100-60	IC UPC1377C					
IC503	8-759-801-98	IC LA7830					
IC504	8-759-929-62	IC MC7812CT					
IC505	8-759-009-51	IC MC14538BF					
IC831	8-759-509-29	IC XRU4011BF					
IC832	8-759-509-37	IC XRU4070BF					
IC833	8-759-009-51	IC MC14538BF					
IC1601	8-759-509-91	IC XRA10393F					
		<COIL>					
L501	1-410-093-11	INDUCTOR 33MMH					
L502	1-410-665-31	INDUCTOR 15UH					
L503	1-424-625-11	COIL, CHOKE (PMC) 381.4UH					
L506	1-412-530-31	INDUCTOR 27UH					
L1601	1-459-155-00	COIL (WITH CORE) 47UH					
L1602	1-424-626-12	COIL, CHOKE 390UH					
L1603	1-410-397-21	FERRITE BEAD INDUCTOR					
		<TRANSISTOR>					
Q501	8-729-901-01	TRANSISTOR DTC144EK					
Q502	8-729-901-01	TRANSISTOR DTC144EK					
Q503	8-729-901-06	TRANSISTOR DTA144EK					
Q504	8-729-901-01	TRANSISTOR DTC144EK					
Q505	8-729-920-74	TRANSISTOR 2SC2412K-QR					
Q506	8-729-901-01	TRANSISTOR DTC144EK					
Q507	8-729-901-01	TRANSISTOR DTC144EK					
Q508	8-729-920-74	TRANSISTOR 2SC2412K-QR					
Q509	8-729-920-74	TRANSISTOR 2SC2412K-QR					
Q510	8-729-901-06	TRANSISTOR DTA144EK					
Q511	8-729-901-01	TRANSISTOR DTC144EK					
Q512	8-729-920-74	TRANSISTOR 2SC2412K-QR					
Q513	8-729-216-22	TRANSISTOR 2SA1162-G					
Q514	8-729-216-22	TRANSISTOR 2SA1162-G					
Q515	8-729-313-42	TRANSISTOR 2SD1134-C					
Q516	8-729-901-01	TRANSISTOR DTC144EK					
Q517	8-729-901-01	TRANSISTOR DTC144EK					
Q518	8-729-920-74	TRANSISTOR 2SC2412K-QR					
Q519	8-729-920-74	TRANSISTOR 2SC2412K-QR					
Q525	8-729-920-74	TRANSISTOR 2SC2412K-QR					

REF. NO.	PART NO.	DESCRIPTION	REMARK	REF. NO.	PART NO.	DESCRIPTION	REMARK
Q532	8-729-920-74	TRANSISTOR 2SC2412K-QR		R535	1-216-053-00	METAL GLAZE 1.5K 5%	1/10W
Q533	8-729-920-74	TRANSISTOR 2SC2412K-QR		R536	1-212-881-11	FUSIBLE 100 5%	1/4W F
Q833	8-729-216-22	TRANSISTOR 2SA1162-G		R537	1-215-867-00	METAL OXIDE 470 5%	1W F
Q834	8-729-920-74	TRANSISTOR 2SC2412K-QR		R538	1-216-095-00	METAL GLAZE 82K 5%	1/10W
Q835	8-729-920-74	TRANSISTOR 2SC2412K-QR		R539	1-216-095-00	METAL GLAZE 82K 5%	1/10W
Q836	8-729-309-08	TRANSISTOR 2SC1890A		R540	1-216-101-00	METAL GLAZE 150K 5%	1/10W
Q1601	8-729-920-74	TRANSISTOR 2SC2412K-QR		R541	1-216-063-00	METAL GLAZE 3.9K 5%	1/10W
Q1602	8-729-920-74	TRANSISTOR 2SC2412K-QR		R542	1-216-075-00	METAL GLAZE 12K 5%	1/10W
Q1603	8-729-920-74	TRANSISTOR 2SC2412K-QR		R543	1-216-065-00	METAL GLAZE 4.7K 5%	1/10W
Q1604	8-729-216-22	TRANSISTOR 2SA1162-G		R544	1-216-101-00	METAL GLAZE 150K 5%	1/10W
Q1605	8-729-119-80	TRANSISTOR 2SC2688-LK		R545	1-216-041-00	METAL GLAZE 470 5%	1/10W
Q1606	8-729-133-42	TRANSISTOR 2SC2334-L		R546	1-216-091-00	METAL GLAZE 56K 5%	1/10W
Q1607	8-729-920-74	TRANSISTOR 2SC2412K-QR		R547	1-216-121-00	METAL GLAZE 1M 5%	1/10W
Q1608	8-729-920-74	TRANSISTOR 2SC2412K-QR		R548	1-216-107-00	METAL GLAZE 270K 5%	1/10W
Q1609	8-729-920-74	TRANSISTOR 2SC2412K-QR		R549	1-216-101-00	METAL GLAZE 150K 5%	1/10W
Q1610	8-729-920-74	TRANSISTOR 2SC2412K-QR		R550	1-216-356-00	METAL OXIDE 3.9 5%	1W F
Q1611	8-729-920-74	TRANSISTOR 2SC2412K-QR		R552	1-216-061-00	METAL GLAZE 3.3K 5%	1/10W
Q1612	8-729-920-74	TRANSISTOR 2SC2412K-QR		R553	1-216-748-11	METAL GLAZE 39K 5%	1/10W
Q1613	8-729-920-74	TRANSISTOR 2SC2412K-QR		R554	1-216-073-00	METAL GLAZE 10K 5%	1/10W
Q1614	8-729-920-74	TRANSISTOR 2SC2412K-QR		R555	1-216-077-00	METAL GLAZE 15K 5%	1/10W
Q1615	8-729-216-22	TRANSISTOR 2SA1162-G		R557	1-216-057-00	METAL GLAZE 2.2K 5%	1/10W
Q1616	8-729-216-22	TRANSISTOR 2SA1162-G		R558	1-216-049-00	METAL GLAZE 1K 5%	1/10W
Q1617	8-729-216-22	TRANSISTOR 2SA1162-G		R559	1-216-065-00	METAL GLAZE 4.7K 5%	1/10W
Q1618	8-729-216-22	TRANSISTOR 2SA1162-G		R560	1-216-037-00	METAL GLAZE 330 5%	1/10W
<RESISTOR>				R561	1-216-081-00	METAL GLAZE 22K 5%	1/10W
D1619	1-216-295-00	METAL GLAZE 0 5%	1/10W	R562	1-216-053-00	METAL GLAZE 1.5K 5%	1/10W
D1620	1-216-295-00	METAL GLAZE 0 5%	1/10W	R563	1-216-061-00	METAL GLAZE 3.3K 5%	1/10W
JR510	1-216-295-00	METAL GLAZE 0 5%	1/10W	R564	1-249-415-11	CARBON 680 5%	1/4W F
R501	1-216-089-00	METAL GLAZE 47K 5%	1/10W	R565	1-216-059-00	METAL GLAZE 2.7K 5%	1/10W
R502	1-216-089-00	METAL GLAZE 47K 5%	1/10W	R566	1-216-025-00	METAL GLAZE 100 5%	1/10W
R503	1-249-437-11	CARBON 47K 5%	1/4W F	R567	1-216-095-00	METAL GLAZE 82K 5%	1/10W
R504	1-216-073-00	METAL GLAZE 10K 5%	1/10W	R568	1-216-063-00	METAL GLAZE 3.9K 5%	1/10W
R505	1-249-393-11	CARBON 10 5%	1/4W F	R569	1-216-063-00	METAL GLAZE 3.9K 5%	1/10W
R506	1-216-071-00	METAL GLAZE 8.2K 5%	1/10W	R570	1-216-093-00	METAL GLAZE 68K 5%	1/10W
R507	1-216-059-00	METAL GLAZE 2.7K 5%	1/10W	R571	1-216-089-00	METAL GLAZE 47K 5%	1/10W
R508	1-216-085-00	METAL GLAZE 33K 5%	1/10W	R572	1-216-095-00	METAL GLAZE 82K 5%	1/10W
R509	1-216-687-11	METAL CHIP 33K 0.50%	1/10W	R573	1-216-063-00	METAL GLAZE 3.9K 5%	1/10W
R510	1-216-683-11	METAL CHIP 22K 0.50%	1/10W	R574	1-216-063-00	METAL GLAZE 3.9K 5%	1/10W
R511	1-216-675-11	METAL CHIP 10K 0.50%	1/10W	R575	1-216-105-00	METAL GLAZE 220K 5%	1/10W
R512	1-218-761-11	METAL CHIP 240K 0.50%	1/10W	R576	1-216-109-00	METAL GLAZE 330K 5%	1/10W
R513	1-216-065-00	METAL GLAZE 4.7K 5%	1/10W	R577	1-216-105-00	METAL GLAZE 220K 5%	1/10W
R514	1-216-099-00	METAL CHIP 120K 0.50%	1/10W	R578	1-249-457-11	CARBON 6.8 5%	1/4W F
R515	1-216-081-00	METAL GLAZE 22K 5%	1/10W	R579	1-249-457-11	CARBON 6.8 5%	1/4W F
R516	1-216-073-00	METAL GLAZE 10K 5%	1/10W	R591	1-216-063-00	METAL GLAZE 3.9K 5%	1/10W
R517	1-216-107-00	METAL CHIP 270K 0.50%	1/10W	R592	1-216-033-00	METAL GLAZE 220 5%	1/10W
R518	1-249-422-11	CARBON 2.7K 5%	1/4W F	R831	1-216-049-00	METAL GLAZE 1K 5%	1/10W
R519	1-216-085-00	METAL GLAZE 33K 5%	1/10W	R832	1-216-075-00	METAL GLAZE 12K 5%	1/10W
R520	1-216-677-11	METAL CHIP 12K 0.50%	1/10W	R833	1-216-065-00	METAL GLAZE 4.7K 5%	1/10W
R521	1-216-067-00	METAL GLAZE 5.6K 5%	1/10W	R834	1-216-059-00	METAL GLAZE 2.7K 5%	1/10W
R522	1-216-107-00	METAL GLAZE 270K 5%	1/10W	R835	1-216-081-00	METAL GLAZE 22K 5%	1/10W
R523	1-216-081-00	METAL GLAZE 22K 5%	1/10W	R836	1-216-049-00	METAL GLAZE 1K 5%	1/10W
R524	1-216-049-00	METAL GLAZE 1K 5%	1/10W	R837	1-216-075-00	METAL GLAZE 12K 5%	1/10W
R525	1-216-434-11	METAL OXIDE 1.8K 5%	1W F	R838	1-216-049-00	METAL GLAZE 1K 5%	1/10W
R526	1-216-079-00	METAL GLAZE 18K 5%	1/10W	R839	1-216-061-00	METAL GLAZE 3.3K 5%	1/10W
R527	1-249-437-11	CARBON 47K 5%	1/4W F	R840	1-216-097-00	METAL GLAZE 100K 5%	1/10W
R528	1-216-073-00	METAL GLAZE 10K 5%	1/10W	R841	1-216-093-00	METAL GLAZE 68K 5%	1/10W
R529	1-216-073-00	METAL GLAZE 10K 5%	1/10W	R842	1-216-093-00	METAL GLAZE 68K 5%	1/10W
R530	1-216-089-00	METAL GLAZE 47K 5%	1/10W	R843	1-216-065-00	METAL GLAZE 4.7K 5%	1/10W
R531	1-216-089-00	METAL GLAZE 47K 5%	1/10W	R844	1-216-077-00	METAL GLAZE 15K 5%	1/10W
R532	1-216-097-00	METAL GLAZE 100K 5%	1/10W	R847	1-216-049-00	METAL GLAZE 1K 5%	1/10W
R533	1-216-089-00	METAL GLAZE 47K 5%	1/10W	R850	1-216-085-00	METAL GLAZE 33K 5%	1/10W
R534	1-216-097-00	METAL GLAZE 100K 5%	1/10W	R851	1-216-669-11	METAL CHIP 5.6K 0.50%	1/10W
				R852	1-216-675-11	METAL CHIP 10K 0.50%	1/10W
				R853	1-216-105-00	METAL GLAZE 220K 5%	1/10W
				R854	1-216-099-00	METAL CHIP 120K 0.50%	1/10W
				R855	1-216-697-11	METAL CHIP 82K 0.50%	1/10W



REF.NO.	PART NO.	DESCRIPTION	REMARK
<RESISTOR>			
JW009	1-216-295-00	METAL GLAZE 0 5% 1/10W	
JW024	1-216-295-00	METAL GLAZE 0 5% 1/10W	
RO01	1-247-713-11	CARBON 1K 5% 1/4W	
RO02	1-216-295-00	METAL GLAZE 0 5% 1/10W	
RO03	1-216-295-00	METAL GLAZE 0 5% 1/10W	
RO04	1-216-081-00	METAL GLAZE 22K 5% 1/10W	
<VARIABLE RESISTOR>			
RV001	1-241-846-11	RES, VAR, CARBON 20K	
RV002	1-241-846-11	RES, VAR, CARBON 20K	
RV003	1-241-845-11	RES, VAR, CARBON 20K	
RV004	1-241-845-11	RES, VAR, CARBON 20K	
RV005	1-241-845-11	RES, VAR, CARBON 20K	
RV006	1-241-845-11	RES, VAR, CARBON 20K	
RV007	1-226-773-11	RES, ADJ, METAL GLAZE 22K	
RV008	1-226-773-11	RES, ADJ, METAL GLAZE 22K	
RV009	1-226-773-11	RES, ADJ, METAL GLAZE 22K	
RV010	1-226-773-11	RES, ADJ, METAL GLAZE 22K	
RV011	1-226-773-11	RES, ADJ, METAL GLAZE 22K	
RV012	1-226-773-11	RES, ADJ, METAL GLAZE 22K	
<SWITCH>			
S001	1-554-419-00	SWITCH, PUSH (1 KEY)	
S002	1-554-419-00	SWITCH, PUSH (1 KEY)	
S003	1-554-419-00	SWITCH, PUSH (1 KEY)	
S004	1-554-419-00	SWITCH, PUSH (1 KEY)	
S005	1-554-419-00	SWITCH, PUSH (1 KEY)	
S006	1-554-419-00	SWITCH, PUSH (1 KEY)	

	*1-641-724-11	X BOARD	*****
<CONNECTOR>			
CN21	*1-564-518-11	PLUG, CONNECTOR 3P	
<DIODE>			
D21	8-719-023-78	DIODE SEL3810DLC05	
D22	8-719-023-78	DIODE SEL3810DLC05	
D23	8-719-023-78	DIODE SEL3810DLC05	

	A-1394-343-A	S BOARD, COMPLETE	*****
<CAPACITOR>			
C1101	1-163-119-00	CERAMIC CHIP 120PF 5% 50V	
C1102	1-164-004-11	CERAMIC CHIP 0.1MF 10% 25V	
C1103	1-124-589-11	ELECT 47MF 20% 16V	
C1104	1-163-031-11	CERAMIC CHIP 0.01MF 50V	
C1105	1-163-114-00	CERAMIC CHIP 75PF 5% 50V	
C1106	1-163-101-00	CERAMIC CHIP 22PF 5% 50V	
C1107	1-164-004-11	CERAMIC CHIP 0.1MF 10% 25V	
C1108	1-163-119-00	CERAMIC CHIP 120PF 5% 50V	
C1109	1-163-031-11	CERAMIC CHIP 0.01MF 50V	
C1110	1-163-117-00	CERAMIC CHIP 100PF 5% 50V	

REF.NO.	PART NO.	DESCRIPTION	REMARK
C1111	1-163-018-00	CERAMIC CHIP 0.0056MF 10% 50V	
C1112	1-126-160-11	ELECT 1MF 20% 50V	
C1113	1-163-119-00	CERAMIC CHIP 120PF 5% 50V	
C1114	1-163-103-00	CERAMIC CHIP 27PF 5% 50V	
C1115	1-164-004-11	CERAMIC CHIP 0.1MF 10% 25V	
C1116	1-163-114-00	CERAMIC CHIP 75PF 5% 50V	
C1117	1-124-589-11	ELECT 47MF 20% 16V	
C1118	1-164-004-11	CERAMIC CHIP 0.1MF 10% 25V	
C1119	1-163-020-00	CERAMIC CHIP 0.0082MF 10% 50V	
C1120	1-163-097-00	CERAMIC CHIP 15PF 5% 50V	
C1121	1-163-097-00	CERAMIC CHIP 15PF 5% 50V	
C1122	1-163-222-11	CERAMIC CHIP 5PF 0.25PF 50V	
C1123	1-163-097-00	CERAMIC CHIP 15PF 5% 50V	
C1130	1-163-097-00	CERAMIC CHIP 15PF 5% 50V	
C1131	1-163-097-00	CERAMIC CHIP 15PF 5% 50V	
<CONNECTOR>			
CN1101*	1-565-488-11	CONNECTOR, BOARD TO BOARD 12P	
<DIODE>			
D1101	8-719-404-46	DIODE MA110	
D1102	8-719-404-46	DIODE MA110	
<IC>			
IC1101	8-752-056-67	IC CXA1214P	
<COIL>			
L1101	1-408-411-00	INDUCTOR 15UH	
L1102	1-404-496-00	COIL	
L1103	1-404-496-00	COIL	
L1104	1-408-411-00	INDUCTOR 15UH	
L1110	1-412-008-31	INDUCTOR CHIP 15UH	
L1111	1-412-008-31	INDUCTOR CHIP 15UH	
<TRANSISTOR>			
Q1101	8-729-216-22	TRANSISTOR 2SA1162-G	
Q1102	8-729-920-74	TRANSISTOR 2SC2412K-QR	
Q1103	8-729-216-22	TRANSISTOR 2SA1162-G	
Q1104	8-729-216-22	TRANSISTOR 2SA1162-G	
Q1105	8-729-901-01	TRANSISTOR DTC144EK	
Q1106	8-729-901-01	TRANSISTOR DTC144EK	
Q1107	8-729-109-44	TRANSISTOR 2SK94-X4	
Q1108	8-729-920-74	TRANSISTOR 2SC2412K-QR	
<RESISTOR>			
R1101	1-216-053-00	METAL GLAZE 1.5K 5% 1/10W	
R1102	1-216-067-00	METAL GLAZE 5.6K 5% 1/10W	
R1103	1-216-059-00	METAL GLAZE 2.7K 5% 1/10W	
R1104	1-216-073-00	METAL GLAZE 10K 5% 1/10W	
R1105	1-216-031-00	METAL GLAZE 180 5% 1/10W	
R1106	1-216-059-00	METAL GLAZE 2.7K 5% 1/10W	
R1107	1-216-071-00	METAL GLAZE 8.2K 5% 1/10W	
R1108	1-216-039-00	METAL GLAZE 390 5% 1/10W	
R1109	1-216-063-00	METAL GLAZE 3.9K 5% 1/10W	
R1110	1-216-069-00	METAL GLAZE 6.8K 5% 1/10W	
R1111	1-216-065-00	METAL GLAZE 4.7K 5% 1/10W	
R1112	1-216-063-00	METAL GLAZE 3.9K 5% 1/10W	
R1113	1-216-069-00	METAL GLAZE 6.8K 5% 1/10W	

The components identified by Δ in this manual have been carefully factory-selected for each set in order to satisfy regulations regarding X-ray radiation. Should replacement be required, replace only with the value originally used.

Les composants identifiés par une trame et une marque Δ sont critiques pour la sécurité. Ne les remplacer que par une pièce portant le numéro spécifique.

The components identified by shading and mark Δ are critical for safety. Replace only with part number specified.



REF. NO.	PART NO.	DESCRIPTION	REMARK	REF. NO.	PART NO.	DESCRIPTION	REMARK
R1114	1-216-055-00	METAL GLAZE	1.8K 5%	1/10W			
R1115	1-216-061-00	METAL GLAZE	3.3K 5%	1/10W			
R1116	1-216-069-00	METAL GLAZE	6.8K 5%	1/10W			
R1117	1-216-061-00	METAL GLAZE	3.3K 5%	1/10W			
R1118	1-216-073-00	METAL GLAZE	10K 5%	1/10W			
R1119	1-216-049-00	METAL GLAZE	1K 5%	1/10W			
R1120	1-216-097-00	METAL GLAZE	100K 5%	1/10W			
R1121	1-216-121-00	METAL GLAZE	1M 5%	1/10W			
R1122	1-216-039-00	METAL GLAZE	390 5%	1/10W			
R1123	1-216-065-00	METAL GLAZE	4.7K 5%	1/10W			
R1124	1-216-029-00	METAL GLAZE	150 5%	1/10W			
R1125	1-216-029-00	METAL GLAZE	150 5%	1/10W			
R1126	1-216-053-00	METAL GLAZE	1.5K 5%	1/10W			
R1127	1-216-043-00	METAL GLAZE	560 5%	1/10W			
R1128	1-216-049-00	METAL GLAZE	1K 5%	1/10W			
R1129	1-216-091-00	METAL GLAZE	56K 5%	1/10W			
R1130	1-216-295-00	METAL GLAZE	0 5%	1/10W			
R1131	1-216-073-00	METAL GLAZE	10K 5%	1/10W			
R1132	1-216-073-00	METAL GLAZE	10K 5%	1/10W			
R1133	1-216-073-00	METAL GLAZE	10K 5%	1/10W			
R1134	1-216-091-00	METAL GLAZE	56K 5%	1/10W			
<VARIABLE RESISTOR>							
RV1101	1-238-015-11	RES, ADJ, CARBON	4.7K				
RV1102	1-238-013-11	RES, ADJ, CARBON	2.2K				
<TRANSFORMER>							
T1101	1-404-584-11	COIL					

G BOARD (SOPS-1021)							

4-812-134-11	RIVET NYLON, 3.5 ϕ						
<CAPACITOR>							
C601	1-136-889-11	METALIZED FILM	0.22MF 20%	250V			
C602	1-136-889-11	METALIZED FILM	0.22MF 20%	250V			
C603	1-161-973-51	CERAMIC	220PF 10%	400V			
C604	1-161-973-51	CERAMIC	220PF 10%	400V			
C605	1-161-973-51	CERAMIC	220PF 10%	400V			
C608	1-161-742-51	CERAMIC	0.0022MF 20%	400V			
C609	1-161-742-51	CERAMIC	0.0022MF 20%	400V			
C610	1-125-724-11	ELECT	180MF 20%	400V			
C611	1-136-206-21	METALIZED FILM	0.033MF 10%	630V			
C612	1-124-910-51	ELECT	47MF 20%	50V			
C613	1-137-190-91	METALIZED FILM	0.22MF 5%	50V			
C614	1-137-190-91	METALIZED FILM	0.22MF 5%	50V			
C615	1-130-471-91	PE TEREPHTHALATE	0.001MF 5%	50V			
C651	1-161-925-11	CERAMIC	100PF B 10%	500V			
C652	1-128-486-51	ELECT	680MF 20%	50V			
C653	1-128-485-51	ELECT	220MF 20%	50V			
C654	1-130-483-91	PE TEREPHTHALATE	0.01MF 5%	50V			
<CONNECTOR>							
CN610	1-560-436-11	HORIZONTAL PIN ASSY	3P				
CN651	1-564-518-11	PLUG, CONNECTOR	3P				
<DIODE>							
D201	1-8-719-971-08	DIODE ESAC39M 06C					
D601	1-8-719-510-27	DIODE D3S860					
D602	1-8-719-921-20	DIODE 1SS119TD					
D603	1-8-719-981-47	DIODE ERA38-06TP1					
D604	1-8-719-981-47	DIODE ERA38-06TP1					
D605	1-8-719-113-44	DIODE RD20ES-T1B3					
D651	1-8-719-971-08	DIODE ESAC39M 06C					
<IC>							
IC601	1-809-086-12	HIC CH-1018					
IC651	1-8-759-908-15	IC TL431CLP					
PH601	1-8-759-045-81	IC TLP732GR LFP2					
<COIL>							
L601	1-424-616-11	TRANSFORMER, LINE FILTER					
L602	1-424-574-11	L.F.T					
L651	1-424-255-41	COIL, CHOKE (MOLDE) 10UH					
L652	1-424-615-11	COIL, CHOKE					
<TRANSISTOR>							
Q601	1-8-729-322-18	TRANSISTOR 2SK1402A					
<RESISTOR>							
R601	1-205-940-51	CEMENT	1.5 5%	5W	F		
R602	1-205-940-51	CEMENT	1.5 5%	5W	F		
R603	1-215-904-11	METAL OXIDE	100K 5%	2W	F		
R604	1-215-904-11	METAL OXIDE	100K 5%	2W	F		
R605	1-212-865-61	FUSIBLE	22 5%	1/4W	F		
R606	1-247-805-91	CARBON	82 5%	1/4W			
R607	1-260-128-91	CARBON	270K 5%	1/2W			
R608	1-260-128-91	CARBON	270K 5%	1/2W			
R609	1-215-904-51	METAL OXIDE	100K 5%	2W	F		
R610	1-207-455-11	WIRE	0.22 10%	1/2W			
R611	1-247-789-91	CARBON	18 5%	1/4W			
R612	1-247-795-91	CARBON	33 5%	1/4W			
R613	1-215-904-51	METAL OXIDE	100K 5%	2W	F		
R614	1-247-815-91	CARBON	220 5%	1/4W			
R651	1-215-886-51	METAL OXIDE	100 5%	2W	F		
R652	1-215-886-51	METAL OXIDE	100 5%	2W	F		
R653	1-260-107-91	CARBON	4.7K 5%	1/2W			
R654	1-260-107-91	CARBON	4.7K 5%	1/2W			
R655	1-247-867-91	CARBON	33K 5%	1/4W			
R656	1-247-867-91	CARBON	33K 5%	1/4W			
R657	1-247-837-91	CARBON	1.8K 5%	1/4W			
<VARIABLE RESISTOR>							
RV651	1-237-443-11	RES, ADJ, CARBON	1K				
<TRANSFORMER>							
T601	1-450-760-11	TRANSFORMER, CONVERTER					

MISCELLANEOUS							

1-413-720-11	SWITCHING REGULATOR (SOPS-1021)						
1-413-720-31	SWITCHING REGULATOR (SOPS-1021)						

The components identified by shading and mark Δ are critical for safety.
Replace only with part number specified.

Les composants identifiés par une trame et une marque Δ sont critiques pour la sécurité.
Ne les remplacer que par une pièce portant le numéro spécifié.

REF. NO.	PART NO.	DESCRIPTION	REMARK
	1-426-043-00	COIL, DEGAUSSING	
Δ	1-451-319-22	DEFLECTION YOKE (Y9FXC)	
	1-452-126-11	MAGNET	
Δ	1-532-747-11	FUSE, GLASS TUBE (5A/125V)	
	1-544-252-11	SPEAKER	
	1-555-724-00	WIRE, GROUND	
Δ	8-737-151-05	CRT (A20JKU10X)	(PVM-8041Q ONLY)
Δ	8-737-651-05	CRT (M20JMP10X)	(PVM-8044Q ONLY)

ACCESSORIES & PACKING MATERIALS

PART NO.	DESCRIPTION	REMARK	
Δ	1-551-812-11	CORD, POWER (10A/125V)	
	1-690-871-11	CABLE (MINI DIN) SP	
	2-990-241-02	HOLDER (A), PLUG	
	2-990-242-01	HOLDER (B), PLUG	
*	704-301-01	BAG (STANDARD), PROTECTION	
	3-754-506-11	MANUAL, INSTRUCTION	
	4-034-835-01	PLATE, TALLY	
*	4-034-954-01	INDIVIDUAL CARTON	(PVM-8041Q ONLY)
*	4-034-955-01	CUSHION (UPPER) (ASSY)	
*	4-034-956-01	CUSHION (LOWER) (ASSY)	
*	4-035-602-01	INDIVIDUAL CARTON	(PVM-8044Q ONLY)

